

ijet *EXPLORE*
International
Journal of Engineering & Technology

CENTRE OF PROFESSIONAL RESEARCH PUBLICATIONS

ISSN 2049-3444





Home	Scope	Editorial Board	Author Guidelines	Review Process
Call for Papers		Online Submission	Privacy Policy	Archive
Code of Ethics	About Us			

[Submit Paper](#)

[Track your Paper](#)

[Author Guidelines](#)

[Current Issue](#)

[Issue Archive](#)

[Pay Publication Charges](#)

[Recommend to Friend](#)

[Bookmark this Page](#)

[Contact Us](#)

Call for Papers Now Open

[Current Issue](#)

Volume 5,
No.1 ,
January
2015

The International Journal of Engineering & Technology - Editorial Board

Dr Dagou Zeze

Senior Lecturer in Nanotechnology & Microsystems
School of Engineering & Computer Sciences,
Durham University
Durham DH1 3LE, UK
Tel: +44 191 334 2531
Email: d.a.zeze@durham.ac.uk

Dr Min An, CEng, MIMechE, MCICE, MIEngD

Reader in Project and Risk Management
Leader of Safety Risk and Reliability Management
School of Civil Engineering, University of Birmingham
Birmingham B15 2TT, UK
Tel: +44 121 414 5146
Email: M.An@bham.ac.uk

Dr Zhengtao Ding

Senior Lecturer in Control Engineering
Control Systems Centre
School of Electrical and Electronic Engineering
The University of Manchester, M13 9PL, UK
Tel: +44 161 306 4663
Email: zhengtao.ding@manchester.ac.uk

Dr Zhiguo Ding

Lecturer
School of Electrical, Electronic, and Computer Engineering
Newcastle University
Newcastle, NE1 7RU, UK
Tel: +44 191 222 7343
Email: z.ding@newcastle.ac.uk

Dr Wenping Cao

Lecturer in Electrical Machines and Drives
Power Electronics, Drives and Machines Group
School of Electrical, Electronic and Computer Engineering,
Newcastle University
Newcastle, NE1 7RU, UK
Tel: +44 191 222 7326
Email: wenping.cao@newcastle.ac.uk

Dr Kheng-Lim Goh

Senior Lecturer with the School of Mechanical and Systems Engineering
Newcastle University, Singapore Campus
180 Ang Mo Kio Avenue 8
Block P Level 2 Unit 220
Singapore 569830
Tel: +65 6550 0133
Email: kheng-lim.goh@ncl.ac.uk

Dr Haofeng Chen - CEng, MIMechE, FHEA

Senior Lecturer, Department of Mechanical Engineering
University of Strathclyde, James Weir Building
75 Montrose Street, Glasgow, UK, G1 1XJ
Tel: +44 141 548 2036
Email: hahaofeng.chen@strath.ac.uk

Dr. Mohamed Saafi

Senior Lecturer, Department of Civil Engineering
University of Strathclyde, John Anderson Building
107 Rottenrow, Glasgow, UK, G4 0NG
Tel: +44 141 548 4569
Email: m.bensalem.saafi@strath.ac.uk

Dr Lidija Siller

Reader in Nanoscale Science
School of Chemical Engineering and Advanced Materials
Newcastle University
Newcastle, NE1 7RU, UK
Tel: +44 191 222 7858
Email: lidija.siller@ncl.ac.uk

Dr Jianqiao Ye CEng FIMechE

Chair in Mechanical Engineering
Department of Engineering
Lancaster University
Lancaster LA1 4YR
Tel: +44(0)1524592377
Email: j.ye2@lancaster.ac.uk

Dr Jie Zhang

Senior Lecturer
School of Chemical Engineering and Advanced Materials
Newcastle University
Newcastle upon Tyne NE1 7RU, UK
Tel: +44 191 222 7240
Email: jie.zhang@ncl.ac.uk

Prof. Terry Gourlay

Prof. of Bioengineering
Medical Diagnostic Devices & Instrumentation
Faculty of Bioengineering
500 Wolfson Building
University of Strathclyde, UK
Tel: +44 141 548 2000
Email: terry.gourlay@strath.ac.uk

Dr Michael Lau

Senior Lecturer with the School of Mechanical and Systems Engineering
Newcastle University, Singapore Campus
180 Ang Mo Kio Avenue 8
Block P Level 2 Unit 220
Singapore 569830
Tel: +65 6550 0134
Email: michael.lau@ncl.ac.uk

Prof Andreas Demosthenous

Reader in and Head of the Analogue and Biomedical Electronics
Research Group
Department of Electronic & Electrical Engineering
University College London
Torrington Place
London WC1E 7JE, UK
Tel: +44 20 7679 3189
Email: a.demosthenous@ee.ucl.ac.uk

Dr Mohammad Shikh-Bahaei

Senior Lecturer
Research Group: Centre for Telecommunications Research
School of Natural & Mathematical Sciences | Division of Engineering
King's College London
Office: S2.45, Strand Building, Strand Campus, London, UK
Tel: +44 20 7848 2367
Email: m.sbahaei@kcl.ac.uk

Dr Daniel Espino

Marie Curie Research Fellow
School of Mechanical Engineering
University of Birmingham
Birmingham, B15 2TT, UK
Email: d.m.espino@bham.ac.uk

[Home](#) | [Author Guidelines](#) | [Call for Papers](#) | [Code of Ethics](#) |
[Privacy Policy](#) | [Contact us](#) | [About us](#) | [Sitemap](#)
Copyright IJET © 2011-2012 IJET Publications UK



Vol. 2, No.2 February 2012

Pages 116-327

Accepted Refereed Research Articles

- **Nanostructuring of Nanorobots for use in Nanomedicine**
Kal Renganathan Sharma
- **The Flushing Time of an Environmentally Sensitive, Yanbu Lagoon along the Eastern Red Sea Coast**
Alaa M. A. Albarakati
- **A Fast Handoff Mechanism for Wireless LAN**
Sushama Rani Dutta | Rohit Vaid
- **Impact of Atmospheric Gases on Fixed Satellite Communication Link at Ku, Ka and V Bands in Nigeria**
Temidayo V. Omotosho | Aderemi A. Atayero
- **Statistical Correlation of Optimized Gas Turbine Fault Analysis**
Ezenwa A. Ogbonnaya
- **Theoretical Investigation of a Cascaded Fin Thermal Behavior Using MATLAB and Symbolic Math Toolbox**
Abdulmajeed S. AL-Ghamdi
- **Selection of the Best Artificial Lift Method for One of the Iranian Oil Field Using Multiple Attribute Decision Making Methods**
Ehsan Fatahi | Hossein Jalalifar | Pyman Pourafshari | Babak Moradi
- **E-Healthcare/Telemedicine Readiness Assessment of Some Selected States in Western Nigeria**
Emuoyibofarhe O. Justice
- **Development of a Meat Slicing Machine Using Locally Sourced Materials**
Odior, A. O.
- **Performance Evaluation of PSS and STATCOM on Oscillation Damping of a North-Central Power Network of Nigeria Grid System**
Ambafi, J. G. | Nwohu M. N. | Ohize H. O. | Tola, O. J.
- **A Comparative Study of GCSC and TCSC Effects on MHO Distance Relay Setting in Algerian Transmission Line**
Mohamed Zellagui | Abdelaziz Chaghi
- **Study of Auto Purification Capacity of River Atuwara in Nigeria**
Omole, D.O. | Adewumi, I.K. | Longe, E.O. | Ogiye, A.S.
- **The Role of Transmitting Boundaries in Modeling Dynamic Soil-Structure Interaction Problems**
Mohammed Y. Fattah | T. Schanz | Shatha H. Dawood
- **Row of Shear Cracks Moving in Piezoelectric Crystals**
G.E. Tupholme
- **A Computer Program for Pipe Friction Factor Calculation**
Tonye K. Jack
- **Design and Implementation of Web based Remote Laboratory for Engineering Education**
Prashant Kumar Tripathi | Jidhu Mohan M | K V Gangadharan
- **Experimental Investigation of Low Flow Rate, Low Pressure Drop and Heat Transfer in Micro-Channel**
R. Kalaivanan
- **Capacitive Compensation on Three Phase Unbalanced Radial Distribution System Using Index Vector Method**
K.V.S. Ramachandra Murthy | M. Ramalinga Raju
- **The Need of Re-engineering in Software Engineering**
Ahmed Saleem Abbas | W. Jeberson | V.V. Klinsega
- **Encrypted IP Voice Call Communication on Android through Sip Server on 3G GPRS**
Saruchi Kukkar
- **The Potential for Investment in Indonesia's Geothermal Resource**
Phil Smith
- **Geopolymerization of Industrial By-Products and Study of their Stability upon Firing Treatment**
H.M.Khater | Sayieda.R.Zedane
- **Implementation of a Low Cost PWM Voltage Source Multilevel Inverter**

Neelashetty Kashappa | Ramesh Reddy K

- Development Traffic Volume Reduction Caused By Automatic Parking Barrier

Johnnie Ben-Edigbe | Aliffa Ramli

[< Back to Archive](#)

[Home](#) | [Author Guidelines](#) | [Call for Papers](#) | [Code of Ethics](#) | [Privacy Policy](#) | [Contact us](#) | [About us](#) | [Sitemap](#)

Copyright IJET © 2011-2012 IJET Publications UK

Performance Evaluation of PSS and STATCOM on Oscillation Damping of a North-Central Power Network of Nigeria Grid System

Ambafi, J. G., Nwohu M. N., Ohize H. O., Tola, O. J.

Department of Electrical and Electronics Engineering,
Federal University of Technology, Minna, P.M.B. 65, Niger State, Nigeria.

ABSTRACT

This research aims at discussing the effective performances of Power System Stabilizer (PSS) and Static Synchronous Compensator (STATCOM) considered separately in damping oscillations on the 330KV North-Central network of Nigerian grid system. The result of this study reveals a better damping controller between the PSS and STATCOM. Placement of the STATCOM was done optimally using GA, whereas the location of the PSS in requisite generator is determined by eigenvalues analysis and damping coefficient. Simulations were carried out using PSAT to evaluate the performance of the PSS and STATCOM in damping oscillations of North-Central network of Nigeria 330KV grid system. By simulation, it was observed that the damping effect of PSS was limited to the swings of the generator and has little or no effect on the inter-area oscillations while STATCOM has pronounced effect on damping the inter-area oscillations.

Keywords: *Oscillations, Damping, PSS, STATCOM, Grid system, PSAT.*

1. INTRODUCTION

Generator output is usually decided by the turbine mechanical torque, which could be altered by excitation value transiently. This alteration is associated with some disturbances in the form of power swing/oscillations that are usually unwanted. In interconnected large electric power systems, there have been always unwanted spontaneous system oscillations at very low frequencies in order of 0.2-2.0Hz (KUNDUR, 1994). There is need to damp the unwanted power swing by changing output power, controlling the excitation value and reducing the power oscillation in order to have a stable system. The stability of electrical power can most simply be defined as its ability to continue in a stable operation after some disturbances.

The emergence of Power System Stabilizer (PSS) brought some relief in power swing problems. Power utilities worldwide have been using PSS as effective excitation controllers to enhance the system stability (Abido, 2009). However, there have been problems experienced with PSS over the years of operation worldwide. Some of these problems were due to the limited capability of PSS in damping only local modes of electromechanical oscillations. Furthermore, PSS can cause great variations in the voltage profile under severe disturbances and they may even result in leading power factor operation and losing stability (Eriksson, 2008).

The advent of power electronics gave rise to the development of Flexible Alternating Current Transmission Systems (FACTS) devices that effectively damp oscillations by circuits combined with the control

strategies prominent in the modern control systems. FACTS devices have been produced to have a significant impact on the improvement of overall power systems performance. Shunt FACTS controllers, such as Static Var Compensator (SVC) and Static Synchronous Compensator (STATCOM), are capable of effectively damping power swing mode oscillation (Mitsubishi Electric, 2001).

Many researchers have meaningfully contributed on this issue of mitigating power swing oscillations in some network(s) worldwide using PSS and FACTS controllers as discussed below:

Mithulananthan, *et al* (2001), researched on the direct correlation between typical electromechanical oscillations in power systems and Hopf bifurcations, so that Hopf bifurcation theory can be used to design remedial measures to resolve oscillation problems. A placement technique was proposed to identify and rank suitable locations for placing shunt FACTS controllers, for the purpose of oscillation control. In the case of Robak, *et al* (2003), they did a comparative study on the power system stability enhancement using PSS and UPFC with Lyapunov-based controllers. The PSS constitutes a supplementary loop to the Automatic Voltage Regulator (AVR) and UPFC controller. The robustness of both proposed controllers was proved. It was also shown that the proposed controllers used local available measurements to execute the derived control strategy and could be easily applied to power system. Bamasak and Abido (2005) researched on the power system stability enhancement via PSS and STATCOM-based stabilizer when applied independently. They also investigated coordinated application and added a supplementary damping controller to the STATCOM AC

voltage control loop to improve STATCOM power oscillation damping. However, this researched work discusses the performance evaluation of PSS and STATCOM on oscillation damping of the North-central 330kV network of Nigerian grid system.

2. BRIEF OVERVIEW OF NORTH-CENTRAL NIGERIAN GRID SYSTEM

The rising demand of electricity in this country has resulted into building many power stations in different locations around the country. The power generated would have to be transmitted to different load centres' in the country through the national grid. The bulk of electric

energy is transmitted either by the 330kV transmission lines or 132kV transmission lines across the country. But the description and analysis of the North-Central Nigerian grid system will be limited to the 330kV transmission lines in this research work. The 330 kV lines are constructed to have double circuits though on separate towers for reliability and more power transmission capacity. North central network is a subsection of the Nigeria national 330KV lines power grid composed of Niger, Kebbi, Kaduna and Abuja (FCT). This network has three generating stations located at Shiroro, Jebba and Kainji all in Niger state. Also the network has four load centres as shown in figure 1.

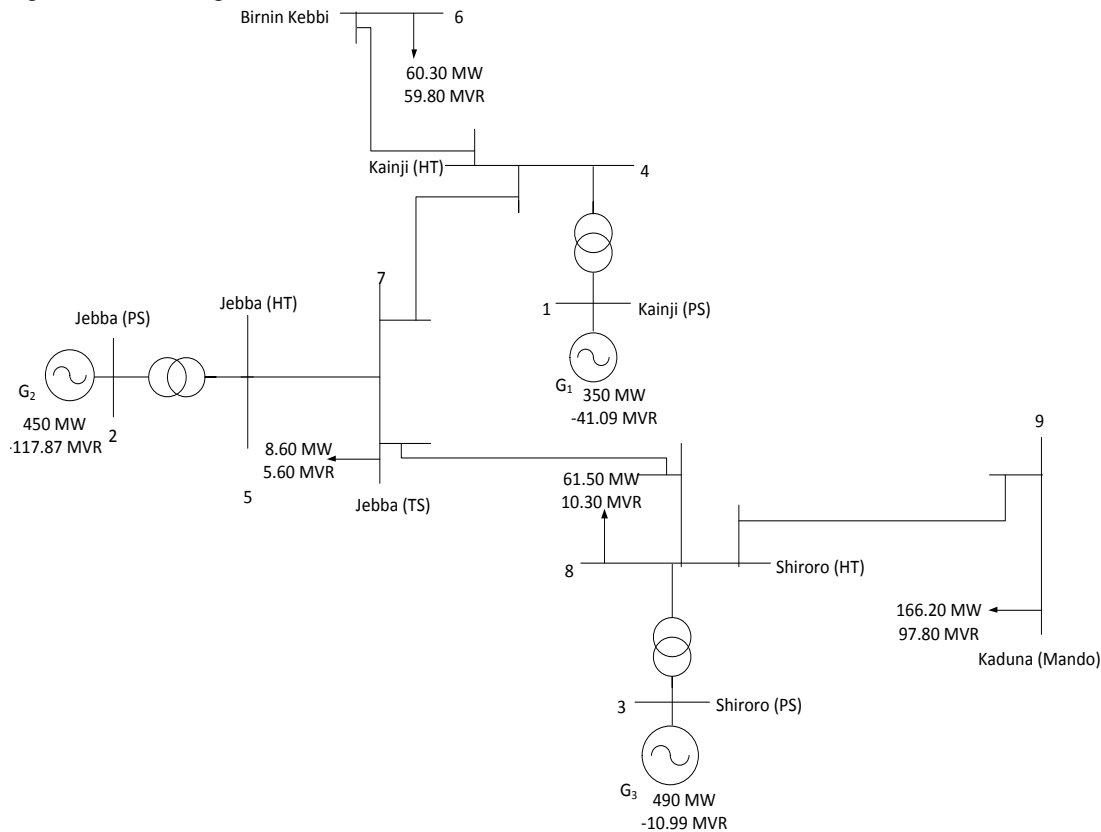

Figure 1. The existing North Central 330kV network of Nigerian grid system.

3. MODELLING OF POWER SYSTEMS, PSS AND STATCOM

In general, power systems are modelled by a set of differential and algebraic equations

(DAE), i.e

$$\begin{aligned} \dot{X} &= f(x, y, \lambda, \rho) \\ 0 &= g(x, y, \lambda, \rho) \end{aligned} \quad (1)$$

Where $x \in \mathcal{R}^n$ is a vector of state variables associated with the dynamic states of generators, loads, and other system controllers; $y \in \mathcal{R}^l$ is a vector of algebraic

variables associated with steady-state variables resulting from neglecting fast dynamics (e.g. some generating sources, most load voltage phasor magnitudes and angles); $\lambda \in \mathcal{R}^l$ is a set of uncontrollable parameters, such as variations in active and reactive power of loads (parameters that drive the system to collapse); and $\rho \in \mathcal{R}^k$ is a set of controllable parameters such as tap and AVR settings, or controller reference voltages. Based on equation (1), we may define the collapse point under the influence of some certain assumptions, as the equilibrium point where the related system Jacobian is singular, i.e., the point $(x_o, y_o, \lambda_o, \rho_o)$ where:

$$\begin{bmatrix} f(x_o, y_o, \lambda_o, \rho_o) \\ g(x_o, y_o, \lambda_o, \rho_o) \end{bmatrix} = F(z_o, \lambda_o, \rho_o) = 0 \quad (2)$$

And its Jacobian has a zero eigenvalue (or zero singular value) (Cañizares, 1995; Nwohu, 2009). Power system models are typically detected by monitoring the eigenvalues of matrix say A as the system parameters (λ , ρ) change (Mithulananthan, et al, 1999).

4. POWER SYSTEM STABILIZER MODEL

Power System Stabilizers are typically used for damping power system oscillations. All models accept as input signals the rotor speed ω , the active power P_g and the bus voltage magnitude V_g of the generator to which the PSS is connected through the automatic voltage regulator. The PSS output signal is the state variable v_s , which modifies the reference voltage v_{ref} of the AVR. The output signal v_s is subjected to an anti-windup limiter and its dynamic is given by a small time constant $T_c = 0.001s^2$ (PSAT, 2005).

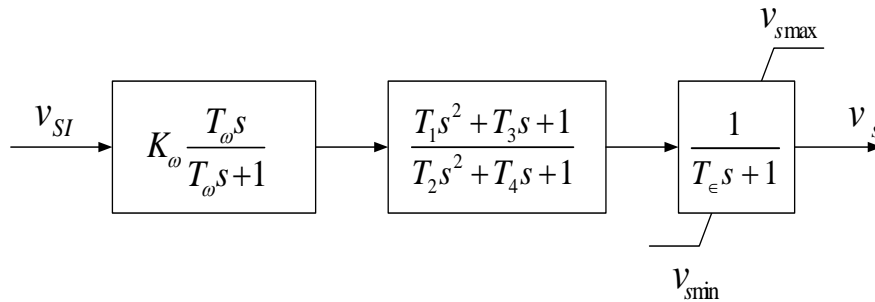

Figure 2. Power system stabilizer Type III

The PSS Type III is depicted in Figure 2, and is described by the equations:

$$\begin{aligned}
 \bullet & v_1 = -(K_\omega v_{SI} + v_1) / T_\omega \\
 \bullet & v_2 = a_1 v_3 + a_2 (K_\omega v_{SI} + v_1) \\
 \bullet & v_3 = -v_2 + a_3 v_3 + a_4 (K_\omega v_{SI} + v_1) \\
 \bullet & v_s = \left(v_2 + \frac{T_3}{T_4} (K_\omega v_{SI} + v_1) - v_s \right) / T_\epsilon
 \end{aligned}
 \tag{3}$$

Where: $a_1 = \frac{1}{T_4}$ $a_2 = \frac{1}{T_4} \left(T_1 - T_2 \frac{T_3}{T_4} \right)$

$a_3 = -\frac{T_2}{T_4}$ $a_4 = 1 - \frac{T_3}{T_4} - \frac{T_2}{T_4} \left(T_1 - T_2 \frac{T_3}{T_4} \right)$

5. MATHEMATICAL MODEL OF A STATCOM ON A SINGLE MACHINE INFINITE BUS NETWORK

A single-machine infinite-bus power system is shown by Figure 3, where a shunt-connected device STATCOM is installed at bus bars. \bar{V}_c , at the ac terminal of the device is controlled by the modulation ratio m and the phase ψ respectively so as to regulate the exchange of active and reactive power between the device and the rest of the

power system. The installed device can have a fuel cell or photovoltaic power generation or energy storage unit integrated into the power grid, which will be connected to the device through the dc capacitor by a dc-dc converter (Sedghisigarchi and Feliachi, 2004; Tan et al., 2004; Arabi and Kundur, 2001; CIGRE report, 1999). Hence the connection of the devices into the power system could have different impacts on power system oscillation stability.

The commonly-used dynamic equations of the generator for the study of power system oscillation stability are (Yu, 1983).

$$\begin{aligned}
 \bullet & \delta = \omega_o (\omega - 1) \\
 \bullet & \dot{\omega} = \frac{1}{M} [P_m - P_t - D(\omega - 1)] \\
 \bullet & \dot{E}_q = \frac{1}{T_{d0}} (-E_q + E_{fd}) \\
 & E'_{fd} = TE(s)(V_{ref} - V_t)
 \end{aligned}
 \tag{4}$$

where: $V_t = V_1$

$P_t = v_{1d} i_{pd} + v_{1q} i_{pq} = x_q i_{pq} i_{pd} + (E'_q - x'_d i_{1d}) i_{sq} = E'_q i_{1q} + (x_q - x'_d) i_{1d} i_{1q}$

$E_q = E'_q - (x_d - x'_d) i_{1d}$

$V_t = \sqrt{v_{1d}^2 + v_{1q}^2} = \sqrt{(x_q i_{1sq})^2 + (E'_q - x'_d i_{1d})^2}$

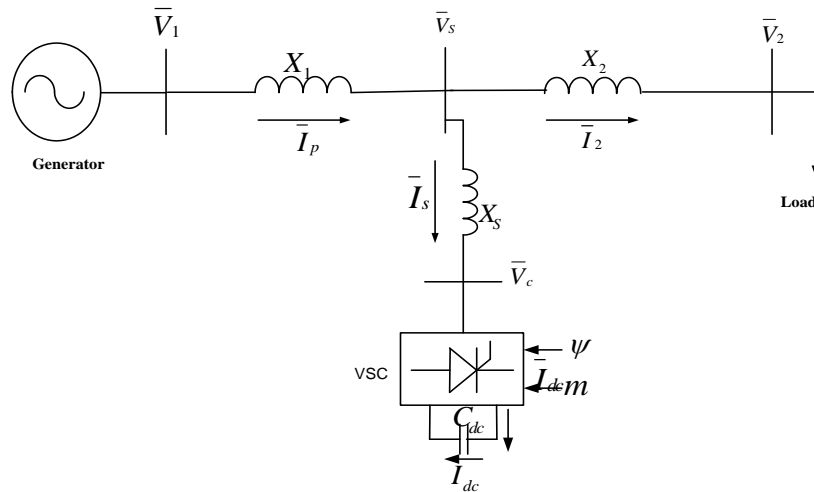

Figure 3. A power system embedded with a shunt-connected STATCOM device

From Figure 3 it can have

$$\begin{aligned} \bar{V}_1 &= jx_1 \bar{I}_p + \bar{V}_s \\ \bar{V}_s &= jx_s \bar{I}_s + \bar{V}_c \\ \bar{V}_s - \bar{V}_2 &= jx_2 (\bar{I}_p - \bar{I}_s) \end{aligned} \quad (5)$$

Equations 5 now give

$$\begin{aligned} jx_s \bar{I}_s + \bar{V}_c - \bar{V}_2 &= jx_2 (\bar{I}_p - \bar{I}_s) \\ \bar{V}_1 &= jx_1 \bar{I}_p + jx_2 (\bar{I}_p - \bar{I}_s) + \bar{V}_2 \end{aligned} \quad (6)$$

In d-q coordinate of the generator, as shown by Figure 3, from Equation (6) it can be obtained that

$$\begin{aligned} \begin{bmatrix} x_2 & -x_s - x_2 \\ x_q' + x_1 + x_2 & -x_2 \end{bmatrix} \begin{bmatrix} i_{pq} \\ i_{sq} \end{bmatrix} &= \begin{bmatrix} -V_c \cos \psi + V_2 \sin \delta \\ V_2 \sin \delta \end{bmatrix} \\ \begin{bmatrix} x_2 & -x_s - x_2 \\ x_d' + x_1 + x_2 & -x_2 \end{bmatrix} \begin{bmatrix} i_{pd} \\ i_{sd} \end{bmatrix} &= \begin{bmatrix} V_c \sin \psi - V_2 \cos \delta \\ E_q' - V_2 \cos \delta \end{bmatrix} \end{aligned} \quad (7)$$

From phasor diagram of Figure 4, in the d-q coordinate of the generator the ac voltage at the VSC terminal is (CIGRE report, 1999).

$$\bar{V}_c = mkV_{dc} (\cos \psi - j \sin \psi) = mkV_{dc} \angle \psi \quad (8)$$

where k is the converter ratio dependent of VSC structure and V_{dc} is the dc voltage across the capacitor C_{dc} in Figure 3. Active power received by the STATCOM from the power system is

$$V_{dc} I_{dc} = i_{sd} v_{cd} + i_{sq} v_{cq} = i_{sd} mkV_{dc} \cos \psi + i_{sq} mkV_{dc} \sin \psi \quad (9)$$

Hence

$$I_{dc} = i_{sd} mk \cos \psi + i_{sq} mk \sin \psi \quad (10)$$

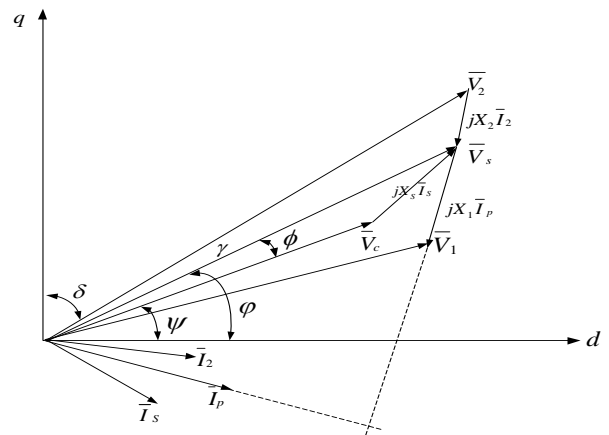

Figure 4. Phasor diagram of power system of Figure 3

STATCOM dynamic equation is

$$\begin{aligned} \dot{V}_{dc} &= \frac{1}{C_{dc}} I_{dc} = \frac{1}{C_{dc}} I_{dc} \\ \dot{V}_{dc} &= \frac{1}{C_{dc}} (i_{sd} mk \cos \psi + i_{sq} mk \sin \psi) \end{aligned} \quad (11)$$

STATCOM ac and dc voltage control functions are

$$m = m_o + K_{ac}(s)(V_s - V_{sref}) \quad (12)$$

$$\phi = \phi_o + K_{dc}(s)(V_{dc} - V_{dcref}) \quad (13)$$

$$\psi = \psi_o + \phi$$

where $K_{ac}(s)$ and $K_{dc}(s)$ is the transfer function of STATCOM ac and dc voltage controller respectively. Eq.(4), (7) and (11)-(13) give the mathematical model of the power system with the embedded STATCOM, including the mathematical description of its dynamic and control function by Eq.(12) and (13).

For the analysis in the following section, an explicit mathematical description of active power delivered along the transmission line from the generator in Figure 3 needs to be established. This is presented as follows.

$$\bar{V}_s = \frac{jx_2}{1 + \frac{x_2}{x_s}} \bar{I}_p + \frac{x_2}{x_s \left(1 + \frac{x_2}{x_s}\right)} \bar{V}_c + \frac{\bar{V}_2}{1 + \frac{x_2}{x_s}} \quad (14)$$

That gives

$$\bar{V}_1 = jx_1 \bar{I}_p + \bar{V}_s = j \left(x_1 + \frac{x_s x_2}{x_s + x_2} \right) \bar{I}_p + \frac{x_2}{x_s + x_2} \bar{V}_c + \frac{x_s}{x_s + x_2} \bar{V}_2 = jx \bar{I}_p + \bar{V}_a \quad (15)$$

Where

$$x = \left(x_1 + \frac{x_s x_2}{x_s + x_2} \right)$$

$$\bar{V}_a = \frac{x_2}{x_s + x_2} \bar{V}_c + \frac{x_s}{x_s + x_2} \bar{V}_2 = a \bar{V}_c + b \bar{V}_2$$

For a single-machine infinite-bus power system without the STATCOM the following voltage equation holds

$$\bar{V}_1 = jx_1 \bar{I}_p + \bar{V} \quad (16)$$

Where, x_1 is the equivalent reactance of the transmission line, \bar{I}_p is the line current and \bar{V} is the voltage at the infinite bus bar. Thus the active power delivered along the transmission line is

$$P_1 = \frac{E'_q V}{x_{d\Sigma}} \sin \delta - \frac{V^2 (x_q - x'_d)}{2x'_{d\Sigma} x_{q\Sigma}} \sin 2\delta \quad (17)$$

Where, δ is the angle (load angle) between E'_q (q axis of the generator) and \bar{V} and

$$x'_{d\Sigma} = x_1 + x'_d \quad (18)$$

$$x_{q\Sigma} = x_1 + x_q$$

$$P_1 = \frac{E'_q}{x_{d\Sigma}} (bV_2 \sin \delta + aV_c \cos \psi) - \frac{(x_q - x'_d)}{x'_{d\Sigma} x_{q\Sigma}} (bV_2 \sin \delta + aV_c \cos \psi) (bV_2 \cos \delta + aV_c \sin \psi) \approx \frac{E'_q V_a}{x_{d\Sigma}} (bV_2 \sin \delta + aV_c \cos \psi) \quad (22)$$

where, $V_c = mkV_{dc}$

Comparing Equations (15) and (16) it can be seen that the power system with the STATCOM of Figure 3 is electrically equivalent to a power system without the STATCOM with an equivalent line reactance to be x and voltage at the infinite bus bar to be \bar{V}_a . Hence by replacing x_1 and V in Equations (17) and (18) by x and V_a respectively, and therefore the active power delivered along the transmission line in the power system of Figure 3 can be deduced, thus

$$P_1 = \frac{E'_q V_a}{x_{d\Sigma}} \sin \delta' - \frac{V^2 (x_q - x'_d)}{2x'_{d\Sigma} x_{q\Sigma}} \sin 2\delta' \quad (19)$$

Where, δ' is the angle between E'_q and \bar{V}_a and

$$x'_{d\Sigma} = x + x'_d \quad (20)$$

$$x_{q\Sigma} = x + x_q$$

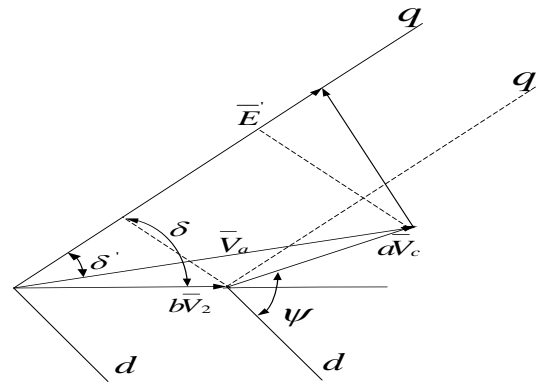

Figure 5. Phasor diagram

From phasor diagram of Figure 5, equation (16) is deduced.

$$V_a \sin \delta' = bV_2 \sin \delta + aV_c \cos \psi \quad (21)$$

$$V_a \cos \delta' = bV_2 \cos \delta + aV_c \sin \psi$$

Hence, from Equations (19), (20) and (21) the following equation is obtained.

6. EIGENVALUE ANALYSIS

The stability of operating point may be analyzed by studying the eigenvalues. The operating point is stable if all of the eigenvalues are on the left-hand side of the imaginary axis of the complex plane, otherwise it is unstable. If any of the eigenvalues appear on or to the right of this axis, the corresponding modes are said to be unstable, as is the system.

The eigenvalues λ are calculated for the state matrix A , which are the non-trivial solutions of the equation (Graham, 2000)

$$A\Phi = \lambda\Phi \quad (23)$$

where, Φ is the right eigenvector of the state matrix A and is n by 1 vector. Quite similarly, the n -row vector Ψ which satisfies

$$\Psi A = \lambda\Psi \quad (24)$$

is called the left eigenvector associated with the eigenvalue λ . Rearranging (23) to solve for λ yields the characteristic equation of matrix A given as

$$\det(A - \lambda I) = 0 \quad (25)$$

and the values of λ which satisfy the characteristic equation are the eigenvalues of state matrix A . These eigenvalues may be real or complex, and are of the form, $\lambda = \sigma \pm j\omega$. The real part of the eigenvalues gives the damping while the imaginary part computes the frequency of oscillation. If the real eigenvalue is negative, the mode decays over the time. The larger the magnitude of the mode, the quicker it decays. But, on the other hand, if the real eigenvalue is positive, the mode is said to have a periodic instability (Snyder, 1997).

If state matrix A is real, the complex eigenvalues always occur in conjugate pairs. The conjugate pair complex eigenvalues ($\sigma \pm j\omega$) correspond to an oscillatory mode. A pair with a positive σ represents an unstable oscillatory mode since these eigenvalues yield an unstable time response of the system. In contrast, a pair with a negative σ represents a desired stable oscillatory mode. Eigenvalues associated with an unstable or poorly damped oscillatory mode are called dominant modes since their contribution dominates the time response of the system. The damped frequency of the oscillation in Hertz is given by:

$$f = \frac{\omega}{2\pi} \quad (26)$$

and the damping factor (or damping ratio) is given by

$$\zeta = \frac{-\sigma}{\sqrt{\sigma^2 + \omega^2}} \quad (27)$$

The oscillatory modes having damping ratio less than 3% are said to be critical. However, a power system is considered to be well damped if the damping for all eigenvalues is greater than 5%.

7. LOCATION OF PSS

The location of PSS was based on the dominant eigenvalues and their damping coefficients. As earlier established, the damping coefficient must not be less than 5% or 0.05. Also, for it to be stable all the real eigenvalues must be on the left hand side of the real axis of a complex plane. The PSAT model figure 6 was simulated and the results obtained are in table 5. From table 5 modes associated to machine 3 (e1q_Syn_3, vr3_Exc_3) appear to have a far less damping ratio of -0.01117787 and the eigenvalues are located on the positive side of the complex plane. Hence it appears to be the best candidate as against machine 1 and 2.

8. OPTIMAL PLACEMENT OF STATCOM USING GENETIC ALGORITHM

The objective function considered is maximization of losses.

Losses in power is defined as

$$LOSSES = R_i \frac{(P_i^2 + Q_i^2)}{|V_i|^2} \quad (28)$$

Where R_i = sum of the resistances of all lines associated to bus i , P_i = active power of bus i .

Q_i = reactive power of bus i and V_i = voltage profile of bus i .

The idea is to locate the bus that has the highest losses which could be considered as the optimal point for placing the device STATCOM. This will include only load buses for STATCOM placement.

A GA based optimization in a MATLAB environment was performed on the case study to determine the optimal point of placing STATCOM. For optimal location of the device, the bus that returns the highest power losses was considered as most suitable bus for locating the device and Cross over=0.25, mutation =1% were considered for 72 generations. After optimization, bus 6 was returned as the best candidate for placement of STATCOM.

9. THE MODEL OF THE CASE STUDY IN PSAT ENVIRONMENT

The North-Central Nigerian network is presently modelled as 9 buses fed by 3 hydro generating stations. Table 1 gives the capacity of the three stations as at 2004. In this

work, power system analysis tool box a version of power simulation software: PSAT 1.3.4 is used in running the

load flow of the North-Central Nigerian Grid network.

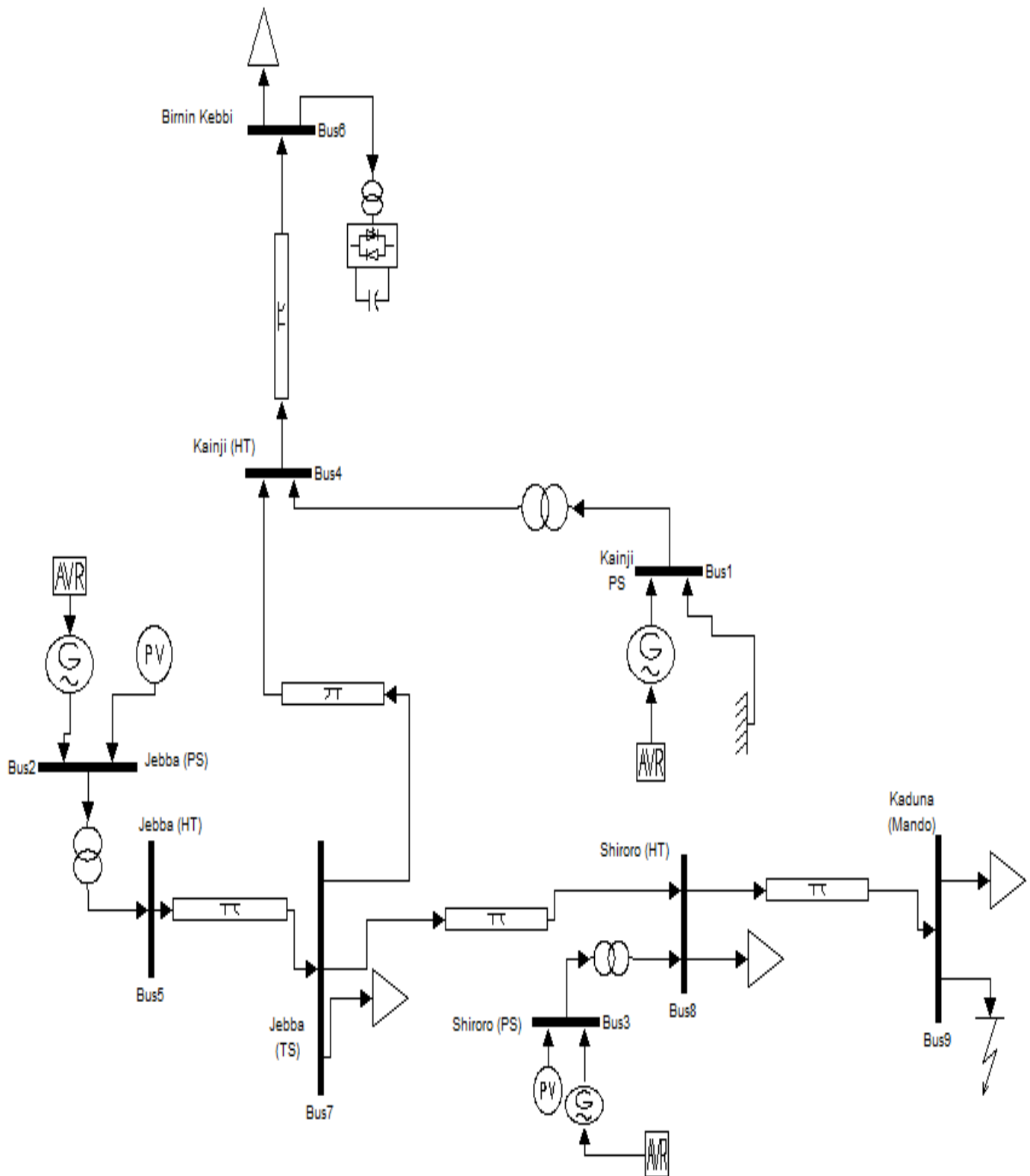

Figure 6. North-Central zone of the 330KV Nigeria grid system with STATCOM

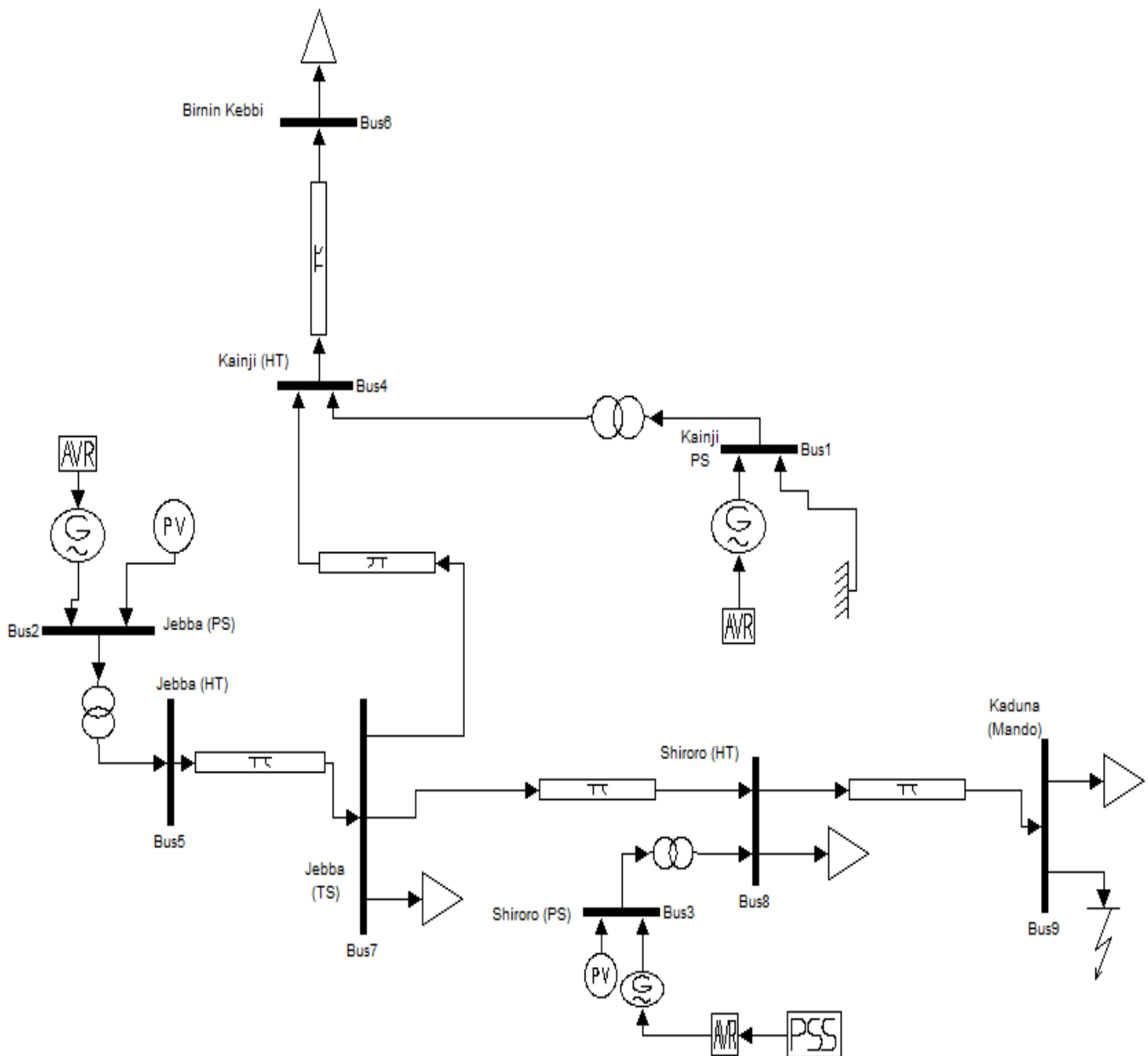

Figure 7. North-Central zone of the 330KV Nigeria grid system with PSS

The results obtained on the performance of power system with the placement of STATCOM and PSS in the North-Central zone of the 330KV Nigeria grid system are shown in the tables. The installation of STATCOM and PSS, have been studied for the optimal location decided by GA and Eigenvalues analysis respectively.

10. SIMULATIONS AND RESULTS

The case study which is a 9bus 330KV North-Central network of the Nigeria grid system with fault located at bus 9 was simulated in PSAT. The PSAT models simulated were figure 6, figure 7. Power flow was first solved by running PSAT simulation with which we obtained the results in table 2. Eigenvalue analysis was later run and the results of interest were obtained as shown in tables 3 to 4. Time Domain Simulations was performed and the result obtained is as shown in figure 8.

Table 1. The Electricity Power Stations in North-Central of Nigeria Grid (PHCN)

S/n	Power Stations	Year Commissioned	Type/Fuel used	Installed Capacity (MW)	No. of Turbines	% in National Grid	Available capacity as at 30/12/2003 (MW)
1	Kainji	1968	Hydro	760	8	12	410
2	Jebba	1986	Hydro	578	6	9	540
3	Shiroro	1990	Hydro	600	4	10	600

Source: PHCN [formerly called, NEPA] NEWS bulletin (2004).

Table 2. Active and Reactive power magnitude of the case study network

Bus no.	Without controller	With STATCOM	With PSS
1	-6.313	-6.3122	-6.313
2	4.5	4.5	4.5
3	4.9	4.9	4.9
6	0.603	0.60408	0.603
7	0.086	0.086	0.086
8	0.615	0.615	0.615
9	1.662	1.662	1.662
Total	6.053	6.05488	6.053

Table 3. Eigenvalues analysis of the case study network without controller

Most Associated States	Dominant Values	Damping ratio
vm_Exc_1, vr1_Exc_1	-24.5645±12.523	0.890907
omega_Syn_3, delta_Syn_3	-1.5741±11.0661	0.140828
e1q_Syn_3, vr3_Exc_3	0.10235±9.2054	-0.011118
e1q_Syn_1, vr3_Exc_2	-1.0636±7.2552	0.145048
e1q_Syn_2, vf_Exc_1	1.0292±4.4907	0.223393

Table 4. Eigenvalues analysis of the case study network with STATCOM

Most Associated States	Dominant Values	Damping ratio
vm_Exc_1, vr1_Exc_1	-24.6081±12.4858	0.891777
delta_Syn_3, omega_Syn_3	-1.4207±11.0422	0.127609
e1q_Syn_3, vr3_Exc_3	-0.17106±8.9768	0.019052
e1q_Syn_1, vr3_Exc_2	-1.1512±6.936	0.163735
e1q_Syn_2, vf_Exc_1	-1.0267±4.4896	0.222929

Table 5. Eigenvalues analysis of the case study network with PSS

Most Associated States	Dominant Values	Damping ratio
vm_Exc_1, vr1_Exc_1	-24.5638±12.5229	0.890904
omega_Syn_3, delta_Syn_3	-0.15279±12.2268	0.012495

e1q_Syn_1, e1q_Syn_3	-0.95944±8.4542	0.112763
e1q_Syn_1, vr3_Exc_2	-0.93578±7.3188	0.126827
e1q_Syn_2, vf_Exc_1	-1.0594±4.4797	0.230141

11. ACTIVE POWER

Table 2 shows how the introduction of STATCOM into the network improved the active power from 6.053p.u. to 6.05488p.u. As for PSS there was no difference with the original network.

Figure 8 shows the effects of PSS and STATCOM in damping oscillations of the active power on the buses. STATCOM has improved the network performance better than PSS.

12. EIGENVALUES ANALYSIS

Table 3 provides the eigenvalues and damping ratio of the most unstable modes. With STATCOM optimally placed at bus6, table 4 shows how the damping ratio of the network has been improved tremendously and the eigenvalues have been shifted to the left hand side of the complex plane, hence increasing the stability of the system. With PSS at generator 3, table 5 shows that there was significant improvement of the damping ratio and the unstable eigenvalues moved to stable region but not as effective as that of STATCOM on table 4.

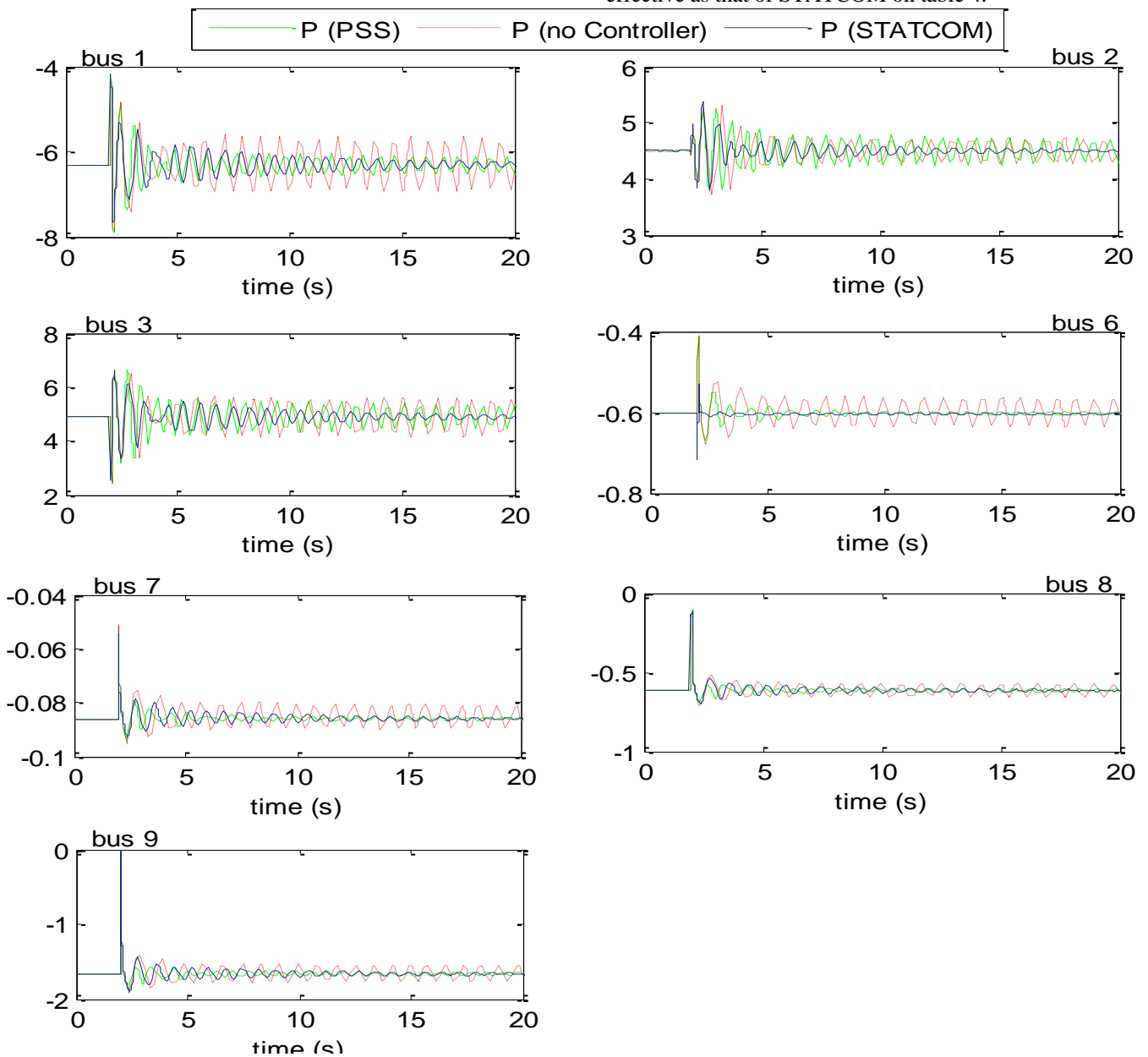

Figure 8. The Active power profile of the case study network

13. CONCLUSIONS

In this study of the Performance Evaluation of PSS and STATCOM in damping oscillations of the case study network was discussed. STATCOM was shown to have improved the active power profile of the system, reduced active power losses and restored the system stability from instability better than PSS. STATCOM has been proven to be of better ability in damping oscillations when compared to PSS.

REFERENCES

- [1] Abido, M. A. (2009), "Power System Stability Enhancement Using Facts Controllers": A Review, the Arabian Journal for Science and Engineering, Volume 34, Number 1B, April, pp. 153-171.
- [2] Arabi S. and Kundur P, (2001) "Stability Modeling of Storage devices in FACTS applications", IEEE PES Summer Meeting, Vol.2, 2001, pp. 767 – 771
- [3] Bamasak S. M. and Abido M. A. (2005), "Robust Coordinated Design of PSS & STATCOM Controllers for Damping Power System Oscillation" 5th PSCC, Liege, 22-26 August Session 32, Paper 5, Page 1-7.
- [4] CIGRE report TF38-01-08, (1999). "Modeling of power electronics equipment (FACTS) in load flow and stability programs", pp. 145.
- [5] Eriksson, R. (2008), "Security-Centred coordinated Control in AC/DC Transmission Systems", Master thesis, TRITA-EE_2008_034.
- [6] Graham, R. (2000), "Power System Oscillation", Kluwer Academic Publishers, 2000, pp. 328
- [7] Griffo, A., Lauria, D., and Carpinelli, G. (2006), "Novel FACTS Controllers for Power System Stability Enhancement", Università degli Studi di Napoli Federico II November 2006, pp. 45-48.
- [8] Klaus H. and O'leary, D. (2000), "FACTS for Cost Effective and Reliable Transmission of Electrical Energy", a paper reviewed by the World Bank, April, 2000, pp. 1-11.
- [9] Kundur, P. (1994), "Power System Stability and Control", McGraw Hill, New York, pp. 817-822.
- [10] Mithulananthan, N., Cañizares, C. A. and Reeve, J. (1999), "Hopf Bifurcation Control in Power System Using Power System Stabilizers and Static Var Compensators," Proc. of NAPS'99, pp. 155–163, San Luis Obispo, California, Oct.
- [11] Mithulananthan, N., Cañizares, C. A., Reeve, J. and Rogers, G. J. (2001), "Comparison of PSS, SVC and STATCOM Controllers for Damping Power System Oscillations". Mitsubishi Electric, Mitsubishi Power System Stabilizer (PSS), pp. 1-7.
- [12] Nwohu, M. N. (2009), "Voltage Stability Enhancement of the Nigerian grid system using flexible alternating current transmission system (FACTS) devices", Ph.D. thesis. Abubakar Tafawa Balewa University, Bauchi, Nigeria, pp. 7-12.
- [13] PSAT, (2005), "Power System Analysis Toolbox Documentation for PSAT version 1.3.4", July 14, 2005, pp. 156-168.
- [14] Robak, S., Januszewski, M., Rasolomampionona, D.D. (2003), "Power System Stability Enhancement Using PSS and UPFC Lyapunov-based controllers: A Comparative Study", Paper Presented IEEE Bologna Power Tech Conference, June 23th-26th, Bologna, Italy, 129-140.
- [15] Sedghisigarchi K. and Feliachi A., (2004) "Dynamic and transient analysis of power distribution systems with fuel cells – part II control and stability enhancement", IEEE Trans. on Energy Conversion, Vol.19, No.2, 2004, pp429-434.
- [16] Snyder, A.F. (1997), "Inter-Area Oscillation Damping with Power System Stabilizers and Synchronized Phasor Measurements", thesis (Msc. in Elect.), Faculty of Virginia State University, Feb. 10, 1997.
- [17] Tan Y. T., Kirschen D. S. and Jenkins N., (2004) "A model of PV generation suitable for stability analysis", IEEE Transaction on Energy Conversion, Vol. 19, No.4, 2004, pp748-755.
- [18] Woodford, D. (2004), "How FACTS Controllers Function in an AC Transmission System", IEEE/PES GM-0-7803-8465-2-2004. 17: pp40-51.
- [19] Yu Y. N. (1983), "Electric Power System Dynamics", Academic Press Inc, pp.255.