

Design of an Automated Mobile Corn Starch Processing Model

*¹Kufre Esenowo Jack, ²Uchenna Godswill Onu, ³Nsikak John Affia
⁴Charles Nnanna Okpo, ⁵Emmanuel Okekenwa, and ⁶Samuel Adeniyi

^{1&6}Department of Mechatronics Engineering, School of Electrical Engineering & Technology
Federal University of Technology Minna, Niger State, Nigeria

^{2,4&5}Department of Electrical/Electronic Engineering Technology, School of Engineering Technology
Akanu Ibiam Federal Polytechnic, Unwana, Nigeria

³Department of Electrical/Electronic Engineering, School of Engineering Technology
Akwa Ibom State Polytechnic Ikot Osurua, Ikot Ekpene, Akwa Ibom State, Nigeria

Abstract

This paper presents a design of an automated mobile corn starch processing model for modest applications from the electrical blending system model. The traditional procedure for extracting starch from corn for meals such as ogi, Akamu (pap) etc from maize (pigeon pea) is labour intensive and time demanding hence the need for a smart-self-operated machine for commercial processing of this important food. This model proposes an electro-mechanical system, the electronic subsystem was modelled using Proteus with its code written in Arduino IDE and the mechanical subsystem was modelled using Solid Work. The system as design operates on alternating current power supply. The mechanical design encompasses: hydraulic device control, parts assembling and mobile driving structure. Electrical design encompasses: electrically actuated arms as one of its transfer mechanisms, sensor devices regulated by the microcontroller action, and electric motor for the grinding system. The model design was demonstrated through simulation and the virtual results show the system capability of carrying out corn starch extraction within minimal time. Subsequent research efforts would be geared towards implementing the design on the hardware using the design specifications.

Keywords: Corn Starch, Improved Model, Commercial Application, Mobile Extracting System, Smart Processing

I. Introduction

Corn has played a vital role in ensuring meal sufficiency for human population, this ranges from breakfast, lunch and dinner, although the process is tedious and takes about approximately 60hours (3days) to 120hours (5days) which includes fermentation, washing (separation), starch settlement and dehydration (drying) which are manually carried out [1]. Food produced from corn is called Ogi, Akamu (pap) which can be made from maize (pigeon pea), they are processed locally by soaking it in water for three days for the fermentation process to take place, thereafter conveying it for grinding, it is soaked in water to separate the starch from the chaff, it will be allowed to settle for some hours before dehydrating and drying it for consumption. All these processes are carried out separately and is similar to that of the casava [2]. Extraction machines developed were designed for industrial use without consideration to the rural dwellers who do not have access to industrial machines, though these may be due to the lack of electricity in rural areas. More so, the massive nature of standalone system for fermentation processes as well as grinding is also one of the major challenges. A small automated system of this nature is required. Also, the process of transferring the filtered product from one place to another for dehydration process may subject the starch to contamination, as such, the small-scale corn extraction system incorporated in this design is an improvement. The aim of this work is to design an automated mobile corn starch extraction model for domestic and commercial applications. The specific objectives are to: design an electronic control system, design a mechanical starch extraction and

production system, smart-self-operated system, and write an algorithm capable of coordinating the overall system operation. This proposed system would encourage the production of corn meals locally with ease; and would make way for large scale production using this solar powered system. [3], investigated the outcome of storage on the chemical, microbiological and sensory properties of cassava, the cassava starch-based custard powder was blended as mixture of yellow-fleshed cassava root starch and whole egg powder. The result from their study showed that there are variations in the pasting properties notwithstanding the levels of whole egg powder inclusion, and all the custard powder could form paste below the boiling point of water at the peak time of five minutes [4]. When high quantity of the whole egg powder is used, high protein, iron, and zinc content is produced, but with low amylose and trans-b-carotene contents. This research considers an automated corn starch extraction system, in that cassava has a similar starch content like that of corn, they undergo the same fermentation process which helps to reduce the chemical concentration, as it aids digestion process. This design focuses on corn starch extraction, without consideration of further microbiological analysis. The similarity in cassava and corn starch extraction was evident in [2] cassava starch extraction machine design, the machine consists of the hopper, the mixing unit, the extraction chamber which houses the screw conveyor (auger) and sieve, the discharge outlets and the power unit. It was concluded that the machine can be used for small and medium production of cassava starch.

However, this paper considers adopting its design technicality for implementation, the machine is designed with its shaft connected vertically, where the corn will be blended alongside with the chaff, followed by other design processes. [1] carried out a research on corn starch custard soured with tamarind, soursop and lime, their research was in comparison with ogi, and it was concluded that custard is a suitable food product. Although it is similar to ogi in appearance and viscosity, it lacks the sour taste typical of ogi, which is the prime condiments of a starch product. Extraction and evaluation from tamarind, soursop and lime was added to custard samples, and the physicochemical and sensory properties of the mixture, shows that it has carbohydrate as the major component of the corn gruel and custard samples. Souring agents were added to the custard to enhance dispersibility, consistency, appearance, and viscosity. The procedure for the corn starch extraction is adopted from the above literature, however the evaluations and additions are not the focus of this paper. [5] carried out a research on the evaluation of thermal properties of starch using differential scanning calorimetry. Similarly, a comprehensive understanding of the apparent viscosity profile of corn starch was shown in the research of [6], in terms of the physicochemical and morphological changes that take place during the thermal profiling of starch-water suspension to its respective gel formation. Also, at different stages along the pasting profile, freeze drying samples were studied.[7], developed a cassava mash process handling machine for high quality cassava flour production. Their efforts towards the development of this suitable indigenous machines for cassava processing has made the cassava mash processing more energy-efficient and to meet the Millennium Development Goals, which is aimed at poverty reduction over a stipulated period of time and food sufficiency. This design seeks to introduce a mobile automated model that does not require much human effort, which reduces food hygiene risk to the corn starch production. In another development, a motorized sieving machine for grated and dewatered cassava mash (garri) was developed and tested. This is an important process in the production of garri known as sifting, [8], and it is necessary to sift to remove oversized grain fractions. However, manual cassava mash sieving induces drudgery, fatigue, and time wastage during the processing. In order to reduce drudgery, there is the need to develop a sifting machine to enhance productivity. An electric motor was used to power the machine, and this motor was evaluated at different operating speed; 900rpm, 699rpm and 480 rpm respectively, with loading rate of 10 kg per run for performance test. Their research revealed that the sifting capacity and sifting efficiency of the machine increases to 145.6 kg/h and 92% respectively, with an engine power of 1.815 kW, which in turn increases the speed of operation of both the sifting capacity and sifting efficiency of the machine. With this the corn starch has smaller grains, low water and high viscosity than cassava, which implies that similar idea could be built-on to set up its extraction and processing plants. [9], carried out a study to isolate and characterize starch granules from corn masa which undergo structural and morphological changes during food processing unit operations as they interact with other food ingredients. Their study revealed that for effectiveness in separation and isolation of starch granules from endosperm proteins present in masa, a proteolytic enzyme, thermolysin was used. Having completed their study, they concluded that the

traditional masa preparation process does not uniformly affect all the starch granules in masa. However, some granules are partially or completely gelatinized during the process, while the majority of them survive through the process with minimal morphological/physical damage with varying degrees of internal structural modifications. It has the ability to produce a large amount of the natural polymer of starch through its capacity to utilize large amounts of sunlight [10]. However, the high cost of nanotechnology can make it difficult for its application on a commercial scale. The model in this research is of a modest cost, locally available components and requires little or no human effort in its operation.

[11] reveals that for optimum starch production with cassava, an improved mechanized approach should be considered. This mechanized approach will help in starch extraction, starch processing and dehydration, considering that cassava contains about 60 to 70 percent of water, and deploys water delivery channel, perforated cage for discharge of the dehydrated water, and coordinates the starch delivery to the designated reservoir. [12] carried out an evaluation process on cassava and maize starch and showed that they can be processed in like manner. This was in validation that the starch obtained from both products are insoluble in water. In view of their process similarities, corn starch adopts the same approach for its extraction and processing. [13] concluded that the importance of starch in the economy as one of the major morning meals in Africa, would lead to the exploration of many varieties of corn product. In order to attain a maximal level of starch production, a hybrid of corn starch was introduced, and this design will help to meet the starch demand using the proposed extraction and processing model. In view of this therefore, this research considers the design model for corn starch extraction and production for domestic and commercial purpose by providing an enhanced model as an improvement on the conventional blending system available in the market.

II. Methodology

Materials

The following Hardware Materials were used: Resistor: fixed (1k Ω), Variable (10k Ω); Transistor: NPN(2N2222); Relay: Single pole double throw (SPDT 12V); Electric motor (2.8kW, 1000 to 1500 rpm, 13Amps, 220V); Thick metal enclosure (12mm²); Microcontroller (ATmega 328); PIR Sensor; Ultrasonic Sensor (HC-SR04); Linen Material; Rotated stirrers, Mash; Perforated Vessel; Hydraulic activated Load Cell, Hydraulic Actuators, Electrically Actuated Arm; Light Emitting Diode; Liquid Crystal Display: 16 x 2 and some Jumper Wires. The following software Applications were also used: Arduino IDE, Proteus and Solid Works. Measuring devices used include: Virtual Terminal; Serial Monitor; Virtual Voltmeter and Virtual Ammeter.

Methods

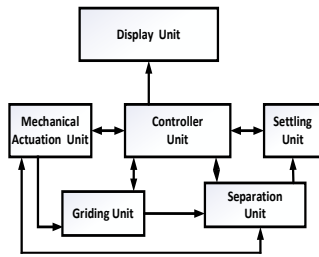

Figure 1: Improved Automated Mobile Corn Starch Processing Model System Architecture

In figure 1, the system is segmented into seven subunits with the following roles:- **Mechanical Actuation unit:** The hydraulic actuated support for the corn starch extraction model provides a rigid support for the system when on operation to relieve the mobile driving mechanism from damage; **Grinding unit:** The pigeon pea that was soaked for 72hours for it to ferment will be transferred to the grinding unit, and this unit is made of a stainless steel and, the pigeon pea is accepted and ground in this unit, and this unit is made up of a stainless steel, and a rotating electric motor attached vertically; **Separation and Settling unit:** The chaff and starch are separated from pigeon pea immediately after grinding process is completed, and the starch is kept to settle down and displace water. This unit separates the water from the starch by displacement techniques; **Electrical Actuation Unit:** This unit provides the transfer mechanism for the drying, separation; **Controller unit:** The electronic components are deployed automatically to regulate the overall performance of the system, lifting system and pneumatic system; and **Display unit:** This is where the status of the system visibly displays operational information to the user.

The process in (i.) to (v.) are mechanically designed with motors and thick metal materials whereas, the motors and the grinding shaft are vertically coupled together, but are controlled by electronic system in (vi.) and monitored through the display in (vii).

III. System Design and Simulation Implementation

i. Electronic and Control Model design

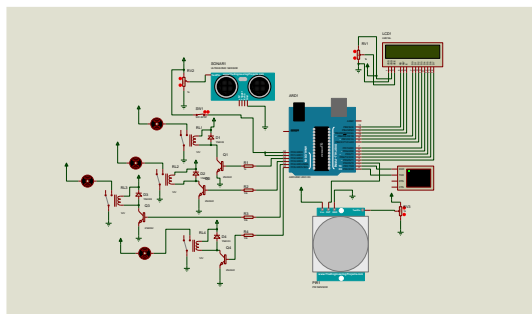

Figure 2: Electronic Circuit for Automated Mobile Corn Starch Processing Model

Principle of Operation

Figure 2 shows the overall operation sequence of the corn-starch extraction system model, with the microcontroller being the

principal system controller. The system receives the already fermented corn into the grinding vessel. The system on sensing the corn grains, automatically opens the grinding sub-unit for grinding, this is made possible with the switching of the motor 1 (grinder motor) from the relay 1 system configuration. After grinding, the ground fluid is transferred to the sieving sub-unit, this is done by automatic switching of motor 2 (Stirrer motor) from the relay 2 system configuration. The sieving sub-unit is made up of a thick metal enclosure with a sieve, a linen bag, a plastic stirrer, and a water inlet hose for the supply of water. The ground fluid and water are discharged concurrently into the thick metal enclosure with the water initially discharged at high speed, while the stirrer does the sifting automatically. On complete discharge of the ground corn fluid, the speed of water discharged decreases until sieving process is completed. However, as the discharge is completely removed, the chaff is made to pass through a delivery hose to where it will be discharged out of the system for further processes. The liquid crystal display, at every sub-unit activity registers the system status for visualization by the operator.

Pseudocode

```

Input  $S_1$  to  $S_4$ 
Initialize  $S_1$  to  $S_5$ 
If  $S_1$  is open
  then accept corn into  $S_1$ 
  else, if  $S_1$  is not open
    then after drain out the water and grind the corn
  If the corn is grided in  $S_2$ 
    then separate the chaff from the starch by washing it in  $S_3$ 
  If the chaff is separated in  $S_3$ 
    then send corn to  $S_4$  for settling and discharges the chaff
    else if chaff is not well separated in  $S_3$ 
      then, after separated corn again from starch and wash in  $S_3$ 
  If settled in  $S_4$ 
    then, send the starch to  $S_5$  for drying
    else if not settled in  $S_4$ 
      then, send starch to  $S_4$  for settling
    then, stop the machine and check if  $S_1$  is open for another
    round of operation.
  
```

ii. Mechanical System Model

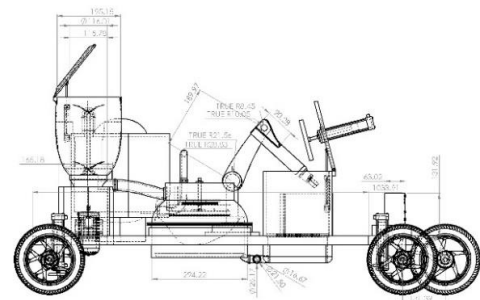

Figure 3: The right side view dimension for the Automated Mobile Corn Starch Processing Model System design

IV. Simulation Results and Discussion

The corn starch extraction prototype design was implemented virtually using electronic and mechanical model, the mechanical

system was modelled using SolidWorks and the electronic model was designed using Proteus and Arduino IDE. The improved corn starch extraction model is an electro-mechanical system with the following subunits: the actuated arms on the grinding system provides the facet where the fermented corn is accepted into the machine, and it is made of stainless steel, this unit is activated when it senses the grain deposit on the tank; the grinding unit is where the corn is ground. It has a stainless steel, a rotating electric motor attached at the base, an inlet to receive corn and water; and an outlet to discharge already ground corn. The grinding system model is designed with a multiple rotating metal blade arranged vertically and mounted to the ended power from the electric motor; the sieving or separating unit receives the ground fluid with water for sieving with vertically placed mesh (net) to separate the end product from the chaff; the settling unit has a linen bag mounted inside a perforated enclosure to receive the fluid as transferred for the starch and water separation; the load cell unit dehydrates water from the corn starch, by deploying a load cell on the linen bag that is mounted inside the perforated vessel; the electrical and power supply unit is a sub-section that is made up of electronic circuit which includes a micro controller, that regulates the activities of the overall system automatically with feedback from this subunit. Whereas the power supply sub-section provides power for the electrical circuit, and to the grinder; the display unit provides visual information of the overall system operation at each stage for operator monitoring.

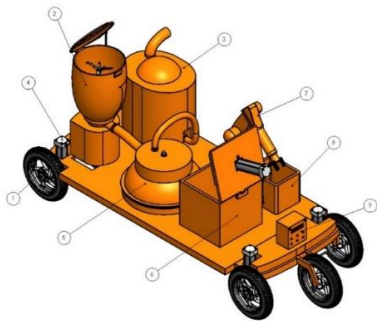

Figure 4: Complete Assembly of the Automated Mobile Corn Starch Processing Model System design System

Figure 4 shows the complete assembling of the Automated Mobile Corn Starch Processing Model

System design system which is made up of 9 parts, part 1 is the mobile driving system, part 2 is the grinding system, part 3 is the water tank, part 4 is the hydraulic support arm to support the system when on operation to relieve the driving system, which is the tyre. This serves to cushion the effect of vibration on the driving system during operation. Part 5 is the sieving system, part 6 is the dehydrating system, part 7 is the electrically actuated arms for the load cell and the chaff deployment. Part 8 is the waste chaff disposal system, and part 9 is the electrical controlling system.

V. Conclusion

An Automated Mobile Corn Starch Processing Model machine was modelled and evaluated, the design simulation information shows that the machine can output up to about 15kg/hr, with the extraction efficiency within the available raw materials. The system adopted an electrically powered blending technique that

was developed for domestic purpose, but is now modified as a new concept for semi-commercial purpose application. From the simulation, the system is predictably expected to discharged 15 litres of starch whenever the stirrers speed reached approximately 100 rpm. The system is designed to operate from public power supply and solar energy (AC) and the control circuit is powered by direct current (DC). The model design was demonstrated through simulation and the virtual results show the system capability in carrying out corn starch extraction within. Subsequent research effort would be geared towards implementing the design on the hardware using the design specifications.

References

- [1] K. O. Salami, A. A. Olorunlambe, B. O. Adesina, F. F. Akinwande, A. M. Ahmed El-Imam, and S. A. Oyeyinka, "Physicochemical and sensory properties of corn starch custard soured with tamarind, soursop and lime," *Hrvat. časopis za prehrambenu Tehnol. Biotehnol. i Nutr.*, vol. 14, no. 3–4, pp. 91–97, 2019.
- [2] L. A. Olutayo, Mogaji K O, and Fasoyin S A, "Development of a Cassava Starch Extraction Machine," *ISSN // Int. J. Comput. Eng. Res.*, vol. 5, no. 11, pp. 2250–3005, 2015.
- [3] W. Awoyale, L. O. Sanni, T. A. Shittu, A. A. Adebowale, and M. O. Adegunwa, "Development of an Optimized Cassava Starch-Based Custard Powder," *J. Culin. Sci. Technol.*, vol. 17, no. 1, pp. 22–44, 2019.
- [4] W. Awoyale, L. O. Sanni, T. A. Shittu, and M. O. Adegunwa, "The pasting, chemical and sensory properties of biofortified cassava root starch-based custard powder," *J. Food Meas. Charact.*, vol. 10, no. 2, pp. 292–301, 2016.
- [5] K. M. Krieger, S. A. Duvick, L. M. Pollak, and P. J. White, "Thermal properties of corn starch extracted with different blending methods: Microblender and homogenizer," *Cereal Chem.*, vol. 74, no. 5, pp. 553–555, 1997.
- [6] N. Rincón-Londoño, L. J. Vega-Rojas, M. Contreras-Padilla, A. A. Acosta-Osorio, and M. E. Rodríguez-García, "Analysis of the pasting profile in corn starch: Structural, morphological, and thermal transformations, Part I," *Int. J. Biol. Macromol.*, vol. 91, pp. 106–114, 2016.
- [7] K. O. Peter, A. S. Leo, and O. A. Simeon, "Cassava Mash Process Handling," in *2nd Conference on Chemical Engineering and Advanced Materials (CEAM)*, 2010, no. February 2015, pp. 1–15.
- [8] A. S. Adekunle, I. O. Ohijeagbon, Y. T. Kareem A. Akande, L. Jilantikiri, A. Sadeeq, and H. D. Olusegun, "Development and performance Evaluation of Cassava Peeling Machine," *Adeleke Univ. J. Eng. Technol.*, vol. 1, no. 1, pp. 66–80, 2018.
- [9] W. S. Ratnayake, A. B. Wassinger, and D. S. Jackson, "Extraction and characterization of starch from alkaline cooked corn masa," *Cereal Chem.*, vol. 84, no. 4, pp. 415–422, 2007.