

See discussions, stats, and author profiles for this publication at: <https://www.researchgate.net/publication/342163419>

Development of an indented cylinder metering device for a tractor drawn manure spreader

Article · October 2019

DOI: 10.5281/zenodo.3521911

CITATIONS

0

READS

31

3 authors:



Agidi Gbabo

68 PUBLICATIONS 194 CITATIONS

[SEE PROFILE](#)



I. M. Gana

FEDERAL POLYTECHNIC BIDA

42 PUBLICATIONS 43 CITATIONS

[SEE PROFILE](#)



Herlina Usman

Jakarta State University

17 PUBLICATIONS 9 CITATIONS

[SEE PROFILE](#)

Some of the authors of this publication are also working on these related projects:



Automation of grain drinks (soya milk, rice milk, kunu etc) processing plant [View project](#)



Development of English Language Teaching Materials in Elementary School based on Direct Metho [View project](#)

Full Length Research Paper

Development of an indented cylinder metering device for a tractor drawn manure spreader

Agidi, G.¹, Gana, I. M.^{2*} and Usman, H.¹

¹Department of Agricultural & Bioresources Engineering, Federal University of Technology Minna, Niger State, Nigeria.

²Department of Agricultural & Bio-environmental Engineering, Federal Polytechnic Bida, Niger State, Nigeria.

*Corresponding Author E-mail: ganaibro74@yahoo.com

Received 12 September 2019; Accepted 11 October, 2019

The research work was carried out to develop an indented cylinder metering device for a tractor drawn manure spreader capable of transporting, metering and uniform spreading of the manure on the farm. Materials of right strength and sizes for the equipment parts were determined and selected based on the design analysis and calculations carried out. Hopper, manure metering system, floor wheels, energy transfer system, machine frame and gear system are the main components of the machinery. The test outcomes of the equipment using cow dung, the largest manure delivery efficiency of 82% was achieved from a velocity of 23 km/h using a metering cylinder with four grooves, whereas a small efficiency of 48% was achieved from a velocity of 8 km/h using a single groove metering cylinder. Also, highest manure

delivery efficiency of 85% was obtained from manure with 8% moisture content (db) whereas low efficiency of 63% moisture content was obtained from manure with 20% moisture content (db). The efficiency of manure delivery improved with both tractor speed and amount of metering groove but reduced with enhanced humidity content of manure. The three parameters therefore have important impacts on the efficiency of manure delivery. It is anticipated that the development of this machinery will decrease human drudgery and enhance the productivity of the farmer.

Keyword: Efficiency, indented, metering, manure, spreading

INTRODUCTION

Organic fertilizer is given much attention and considerations in recent time due to its high rate of nutritional value over inorganic fertilizer. But the use of organic manure in developing countries are limited due to lack of manure applicator machine or equipment which will make application easy, faster and evenly distributed over the farm. Therefore manure is applied using manual method mostly using hand which is tedious, time consuming as such large quantity of this animal waste products are been wasted or discarded. The existing manure applicator machines are very few, big and expensive to acquire by small farm holders because they are foreign product. The use of organic fertilizer needs to be encouraged by developing a potable and affordable manure applicator machine from locally available materials

for ease of maintenance, movement around the farm and easily accessible and affordable, thus increasing crop production rate and the use of animal waste as fertilizer rather than discarding it as waste product.

Manure is a precious and renewable resource used as food in crop production and is regarded as an environmentally friendly bio-fertilizer particularly in this extremely polluted contemporary age (Nanda *et al.*, 2016). Manure is mostly used in Nigeria using manual broadcasting methods that result in human drudgery, more time consumption per unit region and loss of nutrients with application level non-uniformity (Brar *et al.*, 2013). In perspective of the above, appropriate technological intervention is needed to mechanize the manure spreading operation, particularly for big numbers

of the country's tiny and medium-sized landowners, who depend primarily on draught animals. It is therefore necessary to design and develop a tractor-drawn manure applicator. Also it is anticipated that the effective development of this device will decrease human drudgery and enhance the productivity of the farmer.

MATERIALS AND METHODS

Materials

Mild steel materials, welding machine, angle irons, oxygen acetylene gas, drilling machine, tri square, hack saw, vice and electric hand grinder are some of the equipment used during the construction and cow dung was used as manure in testing the machine in this study (Gbabo et al., 2016).

Machine description

The manure spreader is composed of the following component parts:

Hopper

This holds the manure for a short time before its application. It is constructed with 1.5 mm mild steel sheets. The upper part of the hopper is rectangular while the middle and lower sections are trapezoidal and spherical respectively. The sides of the trapezoidal part are designed to slope into the spherical base. The spherical base accommodates the cylindrical metering device. Holes are provided at the two ends of the spherical base to enable shafts connection to the metering cylinder (s). The entire hopper is suspended on the machine frame with the aid of 25 x 25 x 3 mm thick angle iron as shown in (Figures 1 and 2).

Manure metering system

The metering system (Figures 1 and 2) does the function of scooping manure from the base of the hopper and releasing same to the land at recommended rates. Four metering systems are provided to be interchanged for performance assessment of the machine. The manure metering system is a cylinder constructed with a 75 mm diameter pipe. The pipe is indented at various predetermined sections to enable them scoop and hold and release manures at intervals. With 4 mm thick circular plates, the opposite ends of the cylinders are closed and welded to shafts that are suspended on bearings on the machine frame. A speed reduction gear system is connected to one end of the shaft which in

turns carries a speed reduction sprocket.

Ground wheels

The ground wheels (Figures 1 and 2) transmit power obtained from the frictional action between the ground and the wheel when the equipment is drawn by the tractor. Two wheels of 600mm diameter each are provided. It is constructed with a 3 mm thick plate with logs made from 50 x 50 x 4 mm angle irons. The logs are attached to the floor wheels to grip well and enhance the wheel's frictional capacity with the soil. The wheels are linked to two shafts suspended on two bearing sets.

Power transmission system

The power transmission system conducts the job of lowering the tractor's ground speed to a permissible point appropriate for manure metering system operation. It consists of two predetermined size sprockets and a gear system for velocity decrease. A tiny sprocket (16 teeth) attached to the floor wheel shaft and a larger one (48 teeth) attached to the gear box shaft are linked to the chain. To avoid energy loss in transmission, chain and sprockets are used to convey the drive (Figures 1 and 2).

Machine frame

The machine frame is constructed with 75 x 75 x 45 mm mild steel angle iron. The frame carries the whole machine and also bearings on which some rotary parts of machine rests. Also provisions are produced for connecting the tractor to the machine with the 3-point hitching scheme. The equipment illustration is shown in (Plate 1).

Design analysis of machine components

The purpose of the design assessment is to evaluate the design parameters needed to select the different machine components that are appropriate for achieving the required end product. This includes calculating numbers to guide the selection of materials. The machine was intended for an estimated 11 hectares of field capacity per day.

Determination of spreader width

The width of the spreader was calculated based on the assumed capacity of 11 hectors per day it was calculated using a relationship reported by (Gbabo *et al.*, 2016) as given in Equations 1 to 4;

$$Ef = \frac{CE}{CT} \quad (1)$$

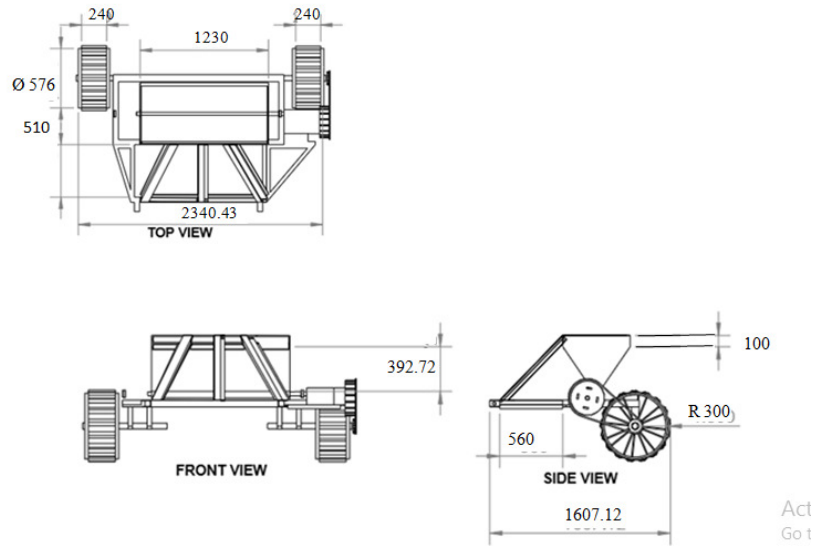

Figure 1. Orthographic projection of the equipment.

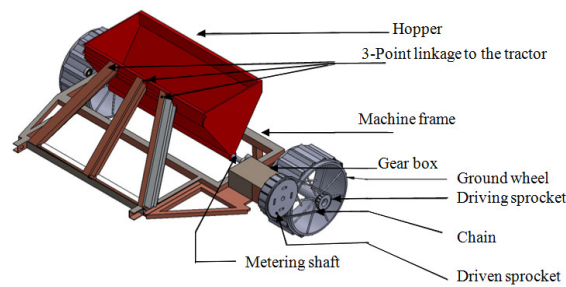

Figure 2. Auto CAD drawing of the equipment.



Plate 1. Developed machine

But $CT = S \times W$ (2)

Therefore

$$EF = \frac{CE}{S \times W} \quad (3)$$

Then $W = \frac{CE}{S \times EF}$ (4)

where, EF is field efficiency (decimal), CE is effective field capacitors (ha/h), S is field speed (km/h)

Design of the manure metering mechanism

The metering mechanism was design to have a diameter and length of 0.05 m and 1.23 m respectively. The mass of the metering mechanism was obtained as reported by Agidi and Andrew, (2015) and is given as:

$$M_{mm} = \rho_{mm} V_{mm} \quad (5)$$

Where M_{mm} is mass of the metering mechanism (kg), ρ_{mm} is the density of the material used for the construction of the metering mechanism, V_{mm} is the volume of the metering mechanism.

Design of the chain and sprocket

To select the length and type of sprocket needed to achieve the expected speed at the manure metering system, consideration was given to the sizes of the sprocket on the ground wheel shaft and the manure metering system. Due to the following variables, a chain was chosen to transmit power from the ground wheel to the manure metering scheme: capacity to absorb vibrations, suitability to transmit power with a bigger pitch centre, smooth operation and simple detection of faults.

Determination of pitch circle diameter of the sprocket

The diameter of the pitch circle was calculated as recorded in equation 6 by Khurmi and Gupta, (2005).

$$d = p \times cosec \left[\frac{180}{T} \right] \quad (6)$$

Where, d is the pitch circle diameter (mm), P is the pitch, T is the number of sprocket teeth.

Design power of sprocket

The design power is reported by Khurmi and Gupta, (2005) as

$$P_D = P_R \times K_S \quad (7)$$

$$But K_S = K_1 \times K_2 \times K_3 \quad (8)$$

Where, P_D is the design power (KW), P_R is the rated power (KW), K_S is the service factor, K_1 is the load factor (1.5), K_2 is the lubrication factor (1), K_3 is the rating factor (1.25)

Determination of the smaller sprocket pitch line speed

The pitch line speed of the lower sprocket was calculated as shown in equation 9 by Khurmi and Gupta, (2005).

$$V_1 = \pi \frac{d_1 N_1}{60} \quad (9)$$

Where, V_1 is the line velocity of the smaller sprockets (m/s), d_1 is lesser sprocket pitch circle diameter (m), N_1 is speed of the smaller sprocket (rpm)

Chain load determination

The load on the chain was calculated as recorded in equation 10 by Khurmi and Gupta, (2005).

$$W = \frac{R_P}{P_V} \quad (10)$$

Where, W is the chain load (KN), R_P is rated power (KW), P_V is pitch line velocity (m/s)

Determination of the chain length needed for transmission of energy

In selecting the appropriate size for correct energy transfer, the length of the chain is mostly needed to overcome excessive slackness and failure. Khumi and Gupta (2005) determine and calculate the length of the chain required to transmit power from the ground wheel to the manure metering system as shown in Equation 11

Determination of length of chain

The length of the chain necessary to transmit power from the ground wheel to the manure metering system is determined and computed by Khumi and Gupta (2005) as given in Equation 11

$$L = K \times P \tag{11}$$

Where, L is the length of the chain (mm), K is number of links, P is pitch in (mm)

Sprocket size determination

The relationship established by Khurmi and Gupta, (2005) in order to select the correct size of the sprocket proportionate to the suitable machine velocity.

$$T_2 = T_1 \times \frac{N_2}{N_1} \tag{12}$$

Where, T_1 is the number of teeth on the larger sprocket, T_2 is the number of teeth on the smaller sprocket, N_1 is the speed of the sprocket ground wheel and N_2 is the expected speed of the sprocket at the gear box (22 rpm)

Determination of weight of the hopper

This was design putting in to consideration angle of repose of cow dung which was found to be between 35°–48°, based on this angle of 60° was considered appropriate in order to allow force flow of the material of the hopper was design to have square cubic shape with rectangular top.

Determination of height of the hopper

The height of the hopper was obtained using the formula for square cubic hopper reported by Singh and Singh, (2014).

$$V = [(L\tau \times B\tau \times H\tau) + \left(\frac{L_1 + L_2}{2}\right) W H_H] \tag{13}$$

$$\frac{V - (L\tau \times B\tau \times H\tau)}{W \left[\frac{L_1 + L_2}{2}\right]} = H_H \tag{14}$$

Where, V is the volume of the spreader (m^3), $L\tau$ is width of the rectangular section of the lopper (m) (1.25m calculated), $B\tau$ is the length of the rectangular section

e.g the hopper (m) (0.5m assumed), $H\tau$ is height of the rectangular section e.g the hopper (m) (0.1m assumed), L_1 is the top length of the conical section (m) (0.5 m assumed), L_2 is the bottom length of the conical section (m) (0.08 m assumed), H_H is height of the conical section (m), W is width of the spreader (m) (1.25m calculated).

Mass of the hopper determination

The weight of the hopper is calculated using standard mass calculation formula as stated by Gbabo et al., (2015) (Figure 3).

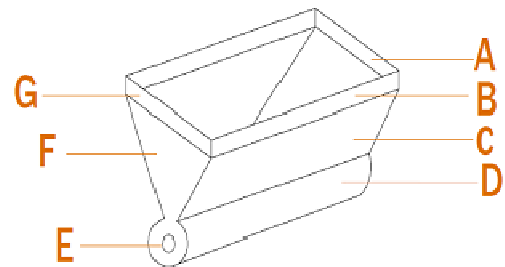

Figure 3. Sketch of the hopper

$$M_H = \rho_H \times V_H \tag{15}$$

$$M_H = \rho_H \times T_H \times A_H \tag{16}$$

$$M_H = \rho_H \times T_H [N_A (L_A \times W_A) + N_B (L_B \times W_B) + N_C (L_C \times W_C) + N_D \left(\frac{L_D + 2r_D}{2}\right) h_F + (N_E \times \pi r_D^2 + 2\pi r_D \times L_D)] \tag{17}$$

Where, M_H is the mass of the hopper (kg), ρ_H is density of the material constructed (kg/m^3), V_H is volume of the material used for hopper construction (m^3), A_H is area of the hopper (m^2), T_H is thickness of the material used for the hopper (m), L_A is length of part A, (m), W_A is width of part A, (m), N_A is number of part with the same dimension with part A, (m), L_B is length of part B, (m), W_B is width of part B, (m), N_B is number of part with the same dimension with part B, (m), L_C is length of part C, (m), W_C is width of part C, (m), N_C is number of part with the same dimension with part C, (m), L_D is length of part D, (m), r_D is radius of part D, (m), N_E is number of part

with the same dimension with part E, (m), r_E is radius of part E, (m), N_F is number of part with the same dimension with part F, (m), L_{TF} is length of top of part F, (m), L_{BF} is length of base of part F, (m), h_F is height part F, (m).

Design of the wheel

The wheels were designed to have traction mechanisms to prevent slippage during operation (Figure 4).

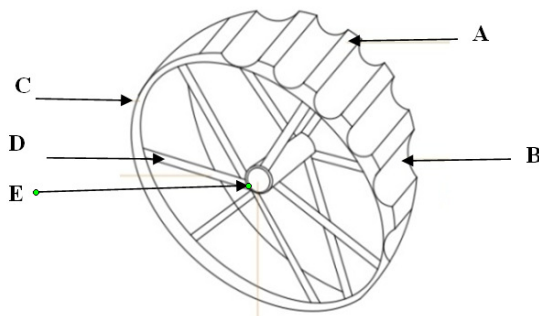

Figure 4. Sketch of the wheels

The mass of the wheel was obtained as follows:

$$M_w = \rho_w V_w \tag{18}$$

$$M_w = \rho_w [(L_A \times W_A \times T_A) + (2\pi r_B \times W_B \times T_B) + N_C (\pi r_C^2 + 2\pi r_B) + N_D (\pi r^2 L_D + 2\pi r_E \times W_E \times T_E)] \tag{19}$$

Where, M_w is the mass of the wheel (kg), ρ_w is density of the material used (kg/m³), V_w is volume of the material used for wheel (m³), L_A is length of part A, (m), W_A is width of part A, (m), T_A is thickness of part A, (m), r_B is radius of part B, (m), W_B is width of part B, (m), T_B is thickness of part B, (m), N_C is number of part with the same dimension with part C, (m), r_C is radius of part C, (m), N_D is number of part with the same dimension with part D, (m), L_D is length of part D, (m), r_D is radius of part D, (m), r_E is radius of part E, (m), W_E is width of part E, (m), T_E is thickness of part E, (m).

Mass of the frame determination

The frame mass was obtained as (Figure 5).

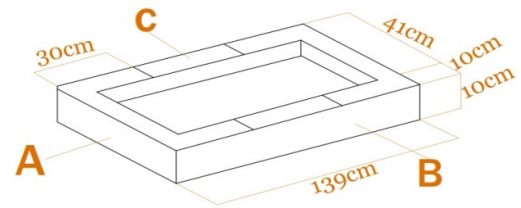

Figure 5. Sketch of the frame

$$M_F = \rho_F \times V_F \tag{20}$$

$$M_F = \rho_F = [N_A (N_{SA} \times L_A \times W_A \times T_A) + N_B (N_{SB} \times L_B \times W_B \times T_B) - (N_C \times L_C \times W_C \times T_C)] \tag{21}$$

Where M_F is mass of the frame (kg), ρ_F is the density of the frame (kg/m³), V_F is volume of the frame (m³), N_A is the number of part A, N_{SA} is the number of sides in part A, L_A is length of part A (m), W_A is width of part A (m), T_A is Thickness of part A (m), N_B is number of part B, N_{SB} is number of sides in part B, L_B is length of part B (m), W_B is width of part B (m), T_B is thickness of part B (m), N_C is number of openings, L_C is length of the opening on part B (m), W_C is width of the opening on part B (m), T_C is thickness of the opening on part B (m)

Power required by the manure spreader

The power required by the manure spreader to discharge the manure is a function of the following: force on the metering shaft, weight of the hopper, material contained in the hopper (manure), weight of the metering Mechanism which was determined as reported by Khurmi and Gupta, (2005).

$$P_T = P_m + P_p \tag{22}$$

$$But P = \frac{2\pi NT}{60} \tag{23}$$

$$P_T = \frac{2\pi}{60} [(N_m \tau_m) + (0.745 \times (\frac{F \times D}{4585.62 \times t}))] \tag{24}$$

$$P_T = \frac{2\pi}{60} [(N_m \times F_m \times \tau_m) + (0.745 \times (\frac{F \times D}{4585.62 \times t}))] \tag{25}$$

$$P_T = \frac{2\pi}{60} [(N_m \times M_m \times \tau_m \times \omega_m^2) + (0.745 \times (\frac{F \times D}{4585.62 \times t}))] \tag{26}$$

$$P_T = \frac{2\pi}{60} [(N_m \times M_m \times \tau_m (\frac{2\pi N_m}{60})^2) + (0.745 \times (\frac{F \times D}{4585.62 \times t}))] \tag{27}$$

Where, P_T is the total power required to spread manure, P_m is the power required by the metering mechanism in (watt), P_p is the power required to pull the machine in (watt), π is a constant (3.142), N is revolution per minute (rpm), N_m is revolution per minute of the metering mechanism (rpm), τ_m is torque generated by metering mechanism (Nm), F is the total force on the machine (kg), D is the distance move by the tractor (m), t is the time taking to move the distance (min), F_m is the total force on the metering mechanism, r_m is the radius of the metering mechanism (m), ω_m is the angular velocity of the metering mechanism

Working procedure of the machine

The manure spreader was coupled to the tractor with the aid of the 3-point hitching system and the desire metering groove type was fixed inside the spreader. The manure sample was loaded into the machine. The tractor was started and allows moving with the selected speed. As the tractor move the spreader wheels also moves. The rotational movement of spreader wheels rotates metering mechanism inside the spreader. As the groove aligns with the manure discharge outlet, the mature was discharge and spread over the plots.

Testing of the machine

The performance of the indented cylinder metering device for a tractor drawn manure spreader was evaluated in accordance with procedures reported by Gbabo *et al.* (2016). Pre-dried cow dung of 9600 kg was obtained from a Fulani settlement in Minna, Niger State, Nigeria. It was divided into two equal parts of 4800 kg each. Two sets of experiments were carried out to investigate the equipment performance. In the first experiment effects of tractor/machine speed on the manure delivery efficiency examined whereas in the second experiment effects of moisture content on the manure delivery efficiency was examined. The experiments were carried out at the Department of Agricultural and Bioresources Engineering, Federal University of Technology Minna, Niger State, Nigeria.

Design of experiments

In the first testing the manure sample was dried to a moisture content of 12% dried bases (d.b), and then divided into forty-eight equal parts of 100 kg each.

Four levels of speeds of 8 km/h, 13 km/h, 18 km/h, and 23 km/h were used to determine the effects of speed on spreading efficiency of the equipment. Four types of metering grooves were used for the experiment. Using equations 28, each experiment was replicated three times and the outcomes acquired are displayed in (Figure 6). For the second trial the manure was dried at four levels of moisture contents of 8%, 12%, 16% and 20% (d.b) and was used to determine the effects of the moisture content on spreading efficiency of the equipment. In this experiment one metering groove type and tractor speed of 12 km/h were used. Using Equations 14, each experiment was replicated three times and the outcomes obtained are displayed in (Figures 6 and 7).

Machine performance determination

The performance of the equipment was determined based on the impacts of velocity and moisture of the manure on the efficiency of its distribution.

The manure delivery efficiency

This is the evenness of spread of manure in the field. It was computed as:

$$D_{eff} = \frac{M_m}{M_e} \times 100 \quad (28)$$

where D_{eff} is the manure delivery efficiency (%), M_m is mass of manure spread on a defined area of land (kg), M_e is the theoretically recommended mass of manure to be spread on the defined land area (kg).

RESULTS AND DISCUSSION

The equipment has been designed, fabricated and the performance test outcomes are shown in (Figures 6 and 7). Figure 6 shows the impacts of tractor / machine velocity on the effectiveness of manure delivery. From the results of effects of speed on the manure delivery efficiency, highest efficiency of 82% was obtained from speed of 23 km/h using metering cylinder with four grooves whereas low manure delivery efficiency of rate of 48% was obtained from speed of 8 km/h using metering cylinder with one groove. Figure 7 represent the results of effects of manure moisture content on manure delivery efficiency. Highest manure delivery efficiency of 85% was obtained from manure with 8% moisture content using metering cylinder with four grooves whereas low efficiency of 35% moisture content was obtained from manure with 20% moisture content using metering cylinder with one groove.

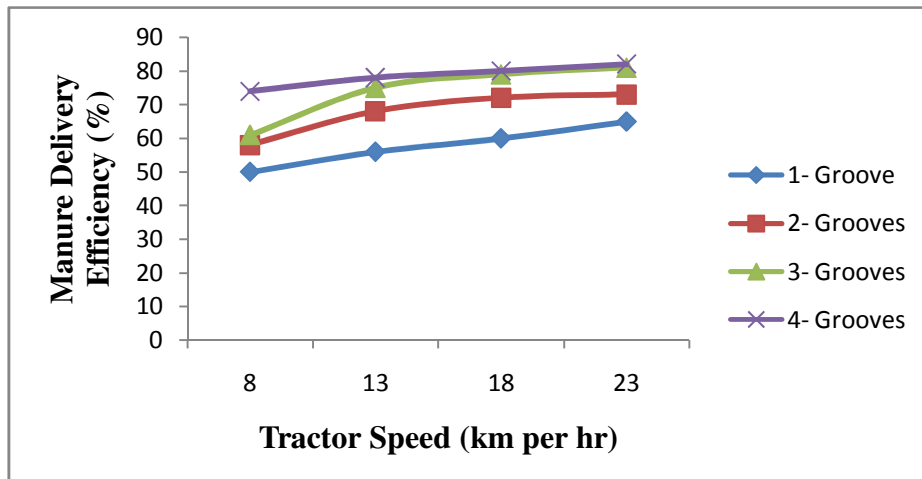

Figure 6. The relationship between uniformity in manure spreading and Tractor/Machine speed at 8% moisture content.

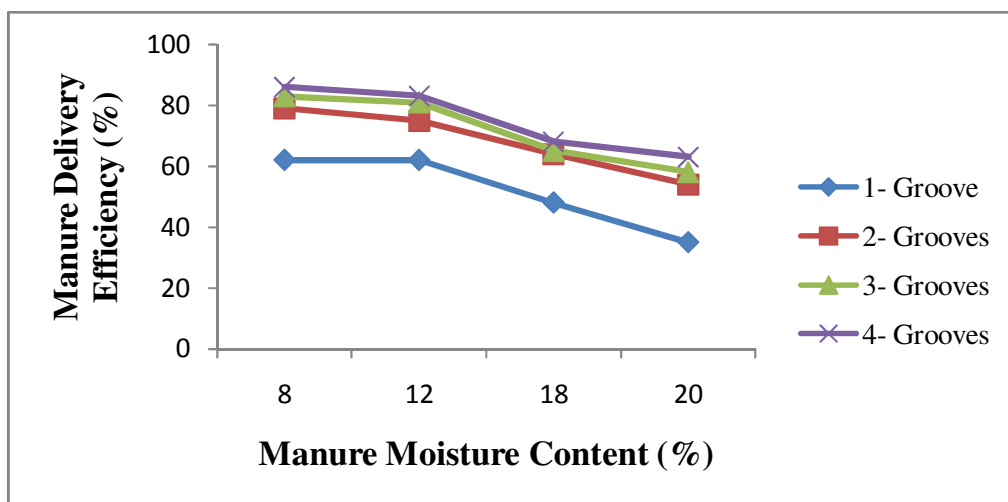

Figure 7. The relationship between uniformity in manure spreading and manure moisture content at tractor speed of 8 km/h.

Effect of tractor/ machine speed on manure delivery efficiency

The manure delivery efficiency of the machine was higher for the entire metering cylinder at higher machine speeds as shown in (Figure 3). The manure delivery efficiency increased from 50% to 65% as the tractor speed increase from 8 km/hr to 23 km/h with metering cylinder with one groove. The efficiency increased significantly with increase in number metering groove. This is in lined with the report of Singh and Singh, (2014) where manure delivery rate was found to increase from 22.9 kg/min to 23.8 kg/min as the speed increased from 0.67 m/s to 0.68 m/s. The highest efficiency was obtained with metering

cylinder with four grooves, the efficiency increased from 74% to 82%. It was obvious for the 3-grooves cylinder there is no any significant difference between delivery efficiency at the higher speeds of 18 km/h and 23 km/h with values 79% and 81% respectively. This trend is similar with the 4- grooves cylinder with values of 80% and 82% for speeds of 18 km/h and 23 km/h respectively. Therefore the manure delivery efficiencies of the machine increased with machine speed 8-18 km/h but became constant as the machine speed change from 18– 23 km/h. This indicates that the best machine speed to

achieve the most efficient manure delivery efficiency ranges from 18 – 23 km/h. On the other hand the best metering cylinder to achieve the most efficient manure delivery efficiency ranges from 3 and 4-metering grooves.

Effect of manure moisture content on delivery efficiency

From Figure 7 the least values of delivery efficiency for all the moisture content levels were obtained with metering cylinder with 1-groove, while the highest values for all the moisture content levels were obtained with metering cylinder with 4-groove. For metering cylinder with 1-groove the manure delivery efficiency decreased from 62% to 35% as the manure moisture content increase from 8% to 20%. This decreased in manure delivery efficiency with increase in moisture content from 8% to 20% is similar with the other types of metering grooves. For metering cylinder with 4-grooves the manure delivery efficiency decreased from 85% to 63% as the manure moisture content increase from 8% to 20%. Also there is no any significant difference between the efficiencies obtained from the 3 and 4-grooves cylinder at higher moisture levels 18 and 20%. Therefore the manure delivery efficiencies of the machine decreased with increase in manure moisture content from 8 % to 20%. No any significant difference was observed in the delivery efficiencies as the moisture content was increased from 18% to 20%. Also at these two higher moisture levels there was no any significant difference in delivery efficiencies between metering cylinder with 3 and 4-grooves. Generally, manures with higher moisture contents recorded lower delivery efficiencies due to the higher degree of wetness which made them to occasionally stick to the manure delivery outlet. This could be as result of clogging and sticking of the manure particles to the hopper wall as result of higher force of attraction between them than the shear forces that hinder particles from adsorption on the wall. This is in line with the report Henry *et al.* (2012) where particles with high moisture content were found to stick to the channel walls as result of the higher force attraction between the particles and the wall. The clogging of the manure particles therefore affects the discharge of the manure. This also agreed with the report of Tiwari, (2016), where high moisture content materials often stick to the parts of the wall as results of clogging and gumming of particles thus affecting the throughput.

Conclusion

The development of this equipment will go a long way in addressing the problem of inadequate availability of manure applicator, as the available manure applicators are imported types which are expensive, gigantic and not

easily accessible to small and middle scale farmers. Also, complement the manual method of manure application using locally hand tool or hand which is tedious, time consuming, and lacks uniformity. In addition, would address health problems such as eye and skin irritation, burning sensation among others associated with ammonium nitrate content of manure due to its readily volatilization upon exposure to the atmosphere. The successful development of this equipment would reduce human drudgery, increase utilization and improve farmer's productivity.

Authors' declaration

We declared that this study is an original research by our research team and we agree to publish it in the journal.

REFERENCES

- Agidi G, Andrew NE (2015). The Physical, Proximate and Ultimate Analysis of Rice Husk Briquettes Produced from a Vibratory Block Mould Briquetting Machine. *International Journal of Innovative Science, Engineering & Technology*, 2(5), 814-822.
- Brar BS, Singh K, Dheri GS (2013). Carbon sequestration and soil carbon pools in a rice–wheat cropping system: effect of long-term use of inorganic fertilizers and organic manure. *Soil and Tillage Research*, 128:30-36.
- Gbabo A, Andrew I, Simeon MI (2015). Design, Fabrication and Testing of a Tractor drawn Soybean Planter. *Soil and Tillage Research*, 44(2):34-49.
- Gbabo A, Andrew NE, Gana IM (2016). Development and testing of a centrifugal fertilizer applicator; Proceedings of the 37th National conference and annual general meeting of the Nigeria Institution of Agricultural Engineers.
- Henry C, Minier J, Lefèvre G (2012). Towards a description of particulate fouling: from single particle deposition to clogging. *Adv Colloid Interface Sci* 185–186. doi:10.1016/j.cis.2012.10.001.
- Khurmi RS, Gupta JK (2005). *Machine Design*. First Multicolour Edition. Enrasia Publishing House (PVT) Ltd. Ram Nagar, New Delhi-110 055.
- Nanda S, Dalai AK, Gökalp I, Kozinski JA. (2016). Valorization of horse manure through catalytic supercritical water gasification. *Waste Management*, Vol.52: 147-158. Available at <https://doi.org/10.1016/j.wasman.2016.03.049>
- Singh RC, Singh CD (2014). Design and development of an animal drawn farmyard manure spreader. *African Journal of Agricultural Research*. Vol.9(44):3245-3250. <https://academicjournals.org/journal/AJAR/article-full-textpdf/0A7202448292>.
- Tiwari H (2016). Cryogenic grinding. Seminar report Department of mechanical Engineering, Uma Naith Singh Institute of Engineering and Technology Veer Bahadur Singh Purvanchal University Jaunpur, India. Available at <https://www.slideshare.net/hmthimanshu/cryogenic-grinding-pdf>.