



# DESIGN ANALYSIS OF WATER-COOLED SOLAR PANEL SYSTEM

Abubakar Jibril,<sup>1</sup> A. B. Hassan<sup>1</sup>, Alkali Babawuya<sup>2</sup>, M. M. Muhammadu<sup>1</sup> and <sup>1</sup>Aminu O. I.

Department of Mechanical Engineering, Federal University of Technology, Minna  
Department of Mechatronics Engineering, Federal University of Technology, Minna

Corresponding Author: [abuzhim2015@gmail.com](mailto:abuzhim2015@gmail.com), 07037070547.

## Abstract

Photovoltaic cells otherwise known as solar panel, converts irradiance into electrical energy. During this process of conversion, the temperature of the PVC increased as it absorbs solar irradiance lead to a reduction in its output power. This problem affects the performance of the PVC especially in the hotter regions of the world. In this research, a water cooling system was designed to the PV panel in order to reduce its temperature. The objective of this research is to carryout design analysis of the system for possible fabrication and performance evaluation. The design analysis results shows an insulator thickness of 5.5 mm and a theoretical water temperature of 62.3°C was attained, which implies a 5.2°C reduction in PVC temperature.

**Keywords:** PV Module, Pressurized Fluid, Flow rate, Heat exchanger, Cooling.

## 1.0 Introduction

The use of solar photovoltaic (PV) electric systems is growing rapidly in the sustainable renewable energy market and is expected to play an important role in the future sustainable energy mix (Saira, Samia, Atta, Hazeema, & Anab, 2018). On the other hand, the initial capital cost of the PV modules and systems has always been a major barrier to the widespread use of this technology over the globe. The initial price of solar PV systems can be reduced by producing more power with the same PV module. The PV module's power output can be increased by increasing the incident solar radiation falling on a PV module according to the inherent characteristics of the PV cells. The distribution of solar radiation is not constant throughout a day. Photovoltaic panels absorb incident solar energy converting directly a small part of it into electrical energy. A limited wavelength of the incoming irradiation on the PV cells is converted into electrical energy with an electrical efficiency of 15 %–20 %, while the remaining energy is wasted as thermal energy causing the major problem of heating of PV modules, consequently increasing its surface temperature and thus decreasing the electrical efficiency (Huan-Liang, 2014). The efficiency of the energy conversion depends strongly on the type of the solar cell and its technology, as well as the operating and environmental conditions such as surface temperature of PV panel, solar irradiation intensity, air temperature and its humidity, air dust, and mass flow rate of cooling fluids (Chandra, Goel, & Ray, 2015).

the development of new technologies of the PV panels and the improvement of existing available ones are necessary to increase the panel electrical efficiency by decreasing its high surface temperature utilizing appropriate cooling techniques. The reduction in the electrical power of the PV module is 0.65% per 1 deg of temperature increase within the range from 22°C to 70°C (Arijadhara & Bhagbat, 2017). In addition, the conversion efficiency and power output of the PV panel decrease by 0.08 % and 0.65 %, respectively, per 1 deg of temperature increment up to 80°C (Swar, Mohammed, & Mustafa, 2017).

Cooling of PV panels can be achieved by either passive or active cooling systems. Active and passive cooling systems may coexist in order to obtain better efficiency. The passive cooling system of the PV panels that is achieved by three basic heat transfer mechanisms such as free convection, conduction, and radiation depends on the buoyancy-driven flow of the working cooling fluid in a duct. The drawbacks of the passive cooling system are dependent on the environmental conditions, its low heat transfer rate, low thermal conductivity, and hence limited temperature reduction. The active cooling system that is performed using liquid or air is comprised of a supplementary device, such as pump to circulate liquids or fan to force air to the panels to extract heat away from the system (Kasaeian, A., 2017). Generally, the active cooling system is used for both increasing the electrical

power output of the PV/T module and supplying available heat to nearby users. Mainly, there are three fundamental working fluids that are employed for the combined PV/T active cooling system: air, water, and refrigerant. The essential advantages of the water cooling system rather than other cooling systems are availability, reliability, low cost, no environmental impact, high thermal conductivity hence higher heat transfer rate, and higher temperature reduction of

/solar energy is one of the most abundant renewable energy resources, but is it characterized with very low conversion efficiency. Another major problem of energy from PV modules is the larger percentage of the solar radiation that incident on the solar panel is converted to heat energy, Therefore, this research seek to develop a water cooling system for a solar panel. Hoping that, this will cool the solar panel thereby improving its electricity conversion efficiency and also harvesting the excess heat to heat up a water for domestic use.

(Bahaidarah, Abdul, Gandhidasan, & Rehman, 2013) investigated the thermal behavior of a PV panel integrated with a water cooling system by producing a 3D models of the PV panels without and with water cooling system and simulated them using ANSYSCEF. The thermal performances of the PV panels without and with water cooling system has been compared and the effect of the inlet water temperature in the cooling case has also been studied detail in method section. A water pump of 373 Watts was used to pump the water flow over the surface of the PV panel from an insulated tank. The experimental measurement of the PV panel with cooling system shows a temperature reduction 7.3 °C in as compared to that without cooling system. This leads to the electrical efficiency of the PV panel with water cooling system has increased 9 %, with a reduction in temperature. Similarity, (Abiola-Ogedengbe, 2016) applied a water-closed circulation to the PV panel to overcome the overheating issues. But in this research work a water pump drained water on the surface of the PV panels and hot water has flowed back into the water tank and circle continues in that manner. The result obtained shows that the PV panel with cooling system has increased an additional 11.6 % of the output power from the PV panel without the cooling system by reducing the temperature of the PV panel.

Photovoltaic (PV) panel is directly converted solar irradiance into electrical energy. The temperature of the PV panel increased as it absorbs solar irradiance lead to a reduction in its output power, (Leow, et al., 2019).This undesired impact can be prevented through the use of a cooling system with PV panel. (Leow, et al., 2019), designed a water cooling system for a PV panel, so as to reduce its temperature. (Saira Iqbal, etal 2016) investigated the effect of water cooling of the energy conversion efficiency of PV cell inclined at 45° using Polycrystalline solar panel having area of 1.2m<sup>2</sup> 36 x 27 cm<sup>2</sup> of area and a power of 12watt (12v and 0.68A), a battery, a 5L water tank. A knob connected to a hose were used to regulate the water flow. Sponge was used to absorb the water flowing over the panel. Pyranamter was used to monitor water temperature and that of solar panel. The volyage and current from the soalr panel were measured with the used of voltmeter and ammeter. A 8 Watt bulb was used to load and discharge the battery used for the study. The result obtained are 0.50 V and 0.10 A. The efficiency of solar panel against mass flow rate in used ranges between 7% - 12% and the highest PV temperature recorded was 48°.

## 2.0 Material And Method

### 2.1 Materials

Materials	Specification
i Solar Panel	80 W
iii DC Pump	12V, 3-6 W
iv Stand	Mild steel
v Robber Hose	1.03 cm

## 2.1 Model description

The sun ray is incident on the solar panel resting on a mild steel stand and the ray heat up the panel, inside the solar panel of 80W are coiled copper tube of 9.5mm diameter.

A DC Pump was used to pump water that flow through the copper tube which in turn cools the solar panel that is already heat up. The water then flows into the heat exchanger tank and heat exchange would take place i.e the water in the tank would heat up and the water from the coiled copper tube would get cool off. The cycle would continue and by so doing the solar panel cools up and in turn would increase the efficiency of PV and intermittently the output of the PV would be recorded.

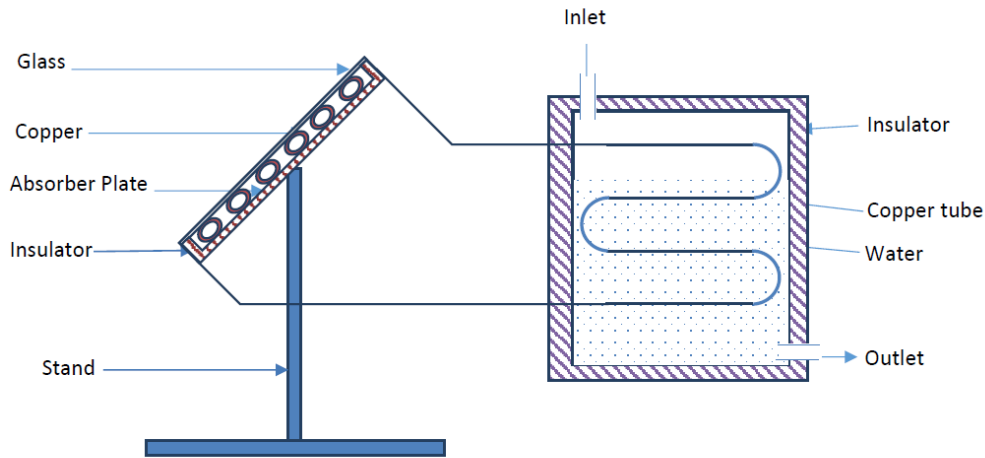

Figure 1: Schematic of the PVC Cooling system

## 2.2 Solar Collector Design

The solar collector convert the solar energy to heat energy, for other useful purposes. The collector is comprise of the absorber plate, the glass, the insulator cover, the fluid tubes and the frame. (see Figure 1). The design analysis of the collector requires the determination of the amount of heat absorbed through radiation by the solar panel into the copper tubes and the insulator thickness required for maximum retention of the absorbed heat.

The useful heat gain from working fluid from the environment is given by equation 1

$$Q = mC_p(T_o - T_i) \quad (\text{Kartini, Ag-Sufiyah, Halim, \& Jedol, 2017}) \quad 1$$

Where  $\dot{m}$ ,  $C_p$ ,  $T_o$ ,  $T_i$ , is the mass flow rate, specific heat, Outlet and Inlet temperature of working fluid. The Hottel-Whiller equation for the useful heat gain from solar collector is given by equation 2.

$$Q_U = A_p F_R [I_R(\tau\alpha) - U_L](T_o - T_i) \quad 2$$

Where  $A_p$ ,  $F_R$ ,  $T_a$ ,  $U_L$ ,  $I_T$ ,  $(\tau\alpha)$  are the area of the absorber plate, Heat removal factor, ambient temperature, overall heat loss coefficient, incident solar radiation and the transmittance absorptance product. Heat removal factor in equation 2 is defined by equation 3;

$$F_R = \frac{\dot{m}c_p}{U_L A_p} \left[ 1 - \exp\left(-\frac{F U_L A_p}{\dot{m}c_p}\right) \right] \quad 3$$

Where  $F$  is the collector efficiency factor. And the thermal efficiency of solar collector is calculated from equation 3.8;

$$\eta_e = \frac{Q_U}{I_T A_p} \quad 4$$

### 2.3 Heat Exchanger Design

The function of the heat exchanger in this system is to absorb heat from the solar panel and discharge the heat into reservoir tanks via copper pipe. According to Jaya, (2019), "The temperature difference ( $\Delta T$ ) is not constant throughout the heat exchanger it varies with the length of heat exchanger." The rate of heat transfer in a heat exchanger was expressed by equation 5;

$$Q = UA\Delta T_m \quad (\text{Efstratios, 2015}) \quad 5$$

Where;

$Q$ = Heat transfer rate (kJ/h) (Btu/h);

$A$  = Heat transfer area (m<sup>2</sup>) (ft<sup>2</sup>);

$U$ = Overall heat transfer coefficient (kJ/h.m<sup>2</sup>.°C) (Btu/h°F);

$\Delta T_m$ = Log mean temperature difference (°C) (°F).

$$\Delta T_m = \frac{(T_1 - T_2) - (t_2 - t_1)}{\ln \frac{T_1 - t_2}{T_2 - t_1}} \quad 6$$

Where;

$T_1$  = Inlet tube side fluid temperature;

$t_2$  = Outlet shell side fluid temperature;

$T_2$  = Outlet tube side fluid temperature;

$t_1$  = Inlet shell side fluid temperature.

Where the mean temperature difference ( $\Delta T_m$ ) between the hot and cold stream is obtained by using equation 7.

$$T_m = \frac{DT_o - DT_L}{\ln(DT_o / DT_L)} \quad 7$$

The overall heat transfer coefficient ( $U$ ) for the heat exchanger based on the heat exchanger tube outside surface was obtained using equation 8,

$$U_o = \frac{1/A_o}{\frac{1}{h_i A_i} + \frac{\ln d_o / d_i}{2K_w L} + \frac{1}{h_o A_o}} \quad 8$$

When designing a vapor absorption air conditioning system there is a need of mass flow rate at each point to be determined.

According to tubular exchange manufactures association (TEMA) the following specifications are used in the design of a heat exchanger.

$0.0666 < (\text{Shell diameter/Tube length}) < 0.2$

$1.25 < \text{Pitch/Outer diameter of tube} < 1.5$

$$\text{Number of tubes} = \frac{\pi C T P . D^2}{4 C L . P^2} \quad 9$$

### 3.0 Results of the design analysis

The result of the design analysis of PVC cooling system obtained are in shown in Table 1.

S/NO	QUANTITY	VALUE	UNIT
1.	Amount of heat absorbed, Q	351.74	W/m <sup>3</sup>
2.	Insulation thickness	5.5	Mm
3.	Efficiency	66.8%	
4.	Area of collector, A <sub>c</sub>	0.0855	m <sup>2</sup>
5.	Area of copper tube, A <sub>c</sub>	0.0339	m <sup>2</sup>
6.	Number of coil copper tube, n	9	

### 4.0 Conclusion

The design analysis of a water cooling system to determine its effect of the performance of a solar panel output was conducted. The system are made of copper tubes laid behind the PVC and water runs through it, with the aid of a heat exchanger. The design analysis result gives the dimension for the fabrication of the PVC water cooling system. The system was designed using an 80 watt solar panel and a 20 liters water tank/heat exchanger. The PVC and the heat exchanger insulator thickness was determine to be 5.5 mm and a theoretical water temperature of 62.3°C was attained, which implies a 5.2°C reduce in PVC temperature.

### References

- Abiola-Ogedengbe, A. (2016). *Experimental investigation of wind effect on solar panels*. Ontario, Canada: ,A master drgree thesis, The University of Western Ontario London, .
- Arjyadhara, P., & Bhagbat, P. (2017, December). Experimental Analysis of Factors Affecting the Power Output of the PV Module. *International Journal of Electrical and Computer Engineering (IJECE)*, 7(6), 3190~3197.
- Bahaidarah, H., Abdul, S., Gandhidasan, P., & Rehman, S. (2013). Performance evaluation of a PV (photovoltaic) module by back surface water cooling for hot climatic conditions. *Energy Journal*, 59, 445-453.
- Chandra, R., G. V., & Ray, C. B. (2015). Thermal performance of a two-pass PV/T air collector. , *Proc. SESI, Baroda*, (pp. 63-69).
- Efstratios, C. (2015). *Modelling and Analysis of Water Cooled Photovoltaics*. Strathclyde: A Masters degree thesis, University of Strathclyde.
- Huan-Liang, T. (2014). Design and Evaluation of a Photovoltaic/Thermal-Assisted Heat Pump Water Heating System. *Journal of Energies*, 7, 3319-3338;. doi: doi:10.3390/en7053319,
- Kartini, S., Ag-Sufiyan, A. H., Halim, R., & Jedol, D. (2017). Evaluation on Cooling Effect on Solar PV Power Output Using Laminar H2O Surface Method. *INTERNATIONAL JOURNAL of RENEWABLE ENERGY RESEARCH*, 7(3).
- Leow, W. Z., Mohd, I. Y., Amelia, A. R., Muhammad, I. M., Safwati, I., Muhammad, I. F., & Rosmi, A. &. (2019). Effect of Water Cooling Temperature on Photovoltaic Panel Performance by Using omputational Fluid Dynamics (CFD). *Journal of Advanced Research in Fluid Mechanics and Thermal Sciences*, 56(1), 133-146.
- Saira, I., Samia, A., Atta, U. M., H. A., & Anab, D. (2018). Effect of Water Cooling on the Energy Conversion Efficiency of PV Cell. *American Scientific Research Journal for Engineering, Technology, and Sciences (ASRJETS)*.
- Swar, A. Z., M. H., & Mustafa, I. (2017). A review of photovoltaic cells cooling techniques. *E3S Web of Conferences* 22.