

See discussions, stats, and author profiles for this publication at: <https://www.researchgate.net/publication/330307290>

DEVELOPMENT AND TESTING OF TRACTOR POWER TAKEOFF (PTO) ELECTRICITY GENERATION SYSTEM

Experiment Findings · January 2019

CITATIONS

0

READS

237

1 author:



I. M. Gana

FEDERAL POLYTECHNIC BIDA

50 PUBLICATIONS 54 CITATIONS

SEE PROFILE

Some of the authors of this publication are also working on these related projects:



Automation of grain drinks (soya milk, rice milk, kunu etc) processing plant [View project](#)



DEVELOPMENT AND TESTING OF TRACTOR POWER TAKEOFF (PTO) ELECTRICITY GENERATION SYSTEM



A. Gbabo¹, I. M. Gana², F. M. Mohammed¹, M. A. Ibrahim¹ and R. A. Ayoola¹

¹Department of Agricultural & Bioresources Engineering, Federal University of Technology Minna, Niger State, Nigeria

²Department of Agricultural & Bio-environmental Engineering, Federal Polytechnic Bida, Niger State, Nigeria

Received: February 02, 2018 Accepted: October 23, 2018

Abstract: This research work was carried out to design, fabricate and test the performance of tractor power take off (PTO) electricity generation system. This idea was conceived in order to utilize the tractor after pre-planting and planting operations with a view to improving its utilization efficiency and improve farmer's income. The concept of the design was to convert the mechanical energy of tractor PTO into electrical energy. The implementation consists of gears, belt and pulley, shafts, gear housing, frame, bearings, AC generator. Test results of the system using five different rotor speeds of 900, 1100, 1300, 1500 and 1800 rpm indicated both output voltage and current generated increased with increase in speed of rotation while the resistance decreases with increase in speed. Highest output voltage and current of 220 V and 34 A, respectively were obtained from speed of 1800 rpm whereas low output voltage and current of 120 V and 6.5 (Ω) were obtained from speed of 900 rpm. On the other hand highest resistance of 9.6 (Ω) was obtained from speed of 900 rpm whereas low resistance of 6.5 (Ω) was obtained from speed of 1800 rpm. The equipment is easy to use, demands less effort and easy to dismantle and assemble for transportation and maintenance.

Keywords: Design, fabricate, generator, power, tractor, voltage

Introduction

Energy is essential for all living being on earth. Electricity is a form of energy called electrical energy. It is sometime called an unseen force because the energy itself cannot be seen, heard, touched, or smelled, however the effect of electricity can be seen in form of a lamp being light. One of the most versatile and widely used forms of energy is electrical energy. Homes and agricultural operations depend so much on this source of energy. Adewumi *et al.* (2015) has observed that power supply from the national grid is inefficient and unreliable, hence the need to provide alternative source of power. According to Abdullah *et al.* (2012), the importance of alternative energy source has become even more crucial matter not only due to the continuous depletion of limited fossil fuel stock but also for the safe, better and greener environment. Adewumi (2014) has noticed that power generation, transmission and distribution has been an indispensable factor in the progress of an economy, ranging from manufacturing, banking, media, health care, aviation among others.

The uses of electricity include powering of machines used in agriculture that requires source of power to operate them. Such machines may be connected to electric motors through belt and pulley. Some of these machines include conveyors, threshers, mixers, grinders, dryers, digesters and irrigation pumps, etc. (Randy, 2004). According to Dyer and Desjardins (2006), lighting is required for residential houses, animal houses and storage structure. Electricity provides the energy to power electric bulbs fluorescent lamp, and to other lighting devices. Also electricity is used in many unit operations such as blanching, pasteurization, sterilization and heating. Drying and ventilation are also very important in processing and storage of farm produce. This process can be powered by electricity using machines such as heat exchangers, dryers (Dyer and Desjardins, 2006). According to Randy (2004) other areas of electricity application in agriculture include communication, security and alarms against thieves and unauthorized entry or exit out of the farm, powering of special sensors for regulating the environment.

In developing countries like Nigeria inadequate and epileptic electricity power supply have caused lots of damages to agricultural produces and also reduce the yield due to epileptic power supply. A standby power system could be considered to

supplement the power supply by Power Holding Company (PHCN).

Hence, the development of a system that converts mechanical energy to electricity is of immense significance in alleviating some of the shortcomings associated with the existing shortage of electricity supply to the farm. Therefore the objective of this study is to design, fabrication and test a tractor power takeoff (PTO) electricity generation system.

Materials and Methods

Description of the system

The electricity generation system from tractor PTO shaft is made up of the following components:

Frames: The frames give rigidity and support to the equipment. It also carries the gear box, pulley system and the alternator. Gear box frame dimension was designed to be 30 x 18 x 30 cm while the dimension of frame for pulley was 64 x 17 x 10 cm as shown in Figs. 1 and 2.

The gears: Two gears made from cast iron were used in the fabrication of the mechanism. The big gear consists of 30 teeth while the small gear consists of 15 teeth (Figs. 1 and 2).

The pulleys: Two pulleys made from 5 mm mild steel plate was used. The diameter of the drive pulley was 250 mm while that of the driven pulley was 150 mm.

Belt: Av-belt was selected for this construction because they are particularly suitable for short drives.

Bearings: This holds the shafts to the frames and allows relative motion of the shafts. They also permit relative motion between the contacting surfaces while carrying load. They reduce the friction and transmit the motion effectively.

The alternator: This is the source of electric power for the mechanism. It converts the mechanical power of the tractor to electrical energy. Generators are rated by the amount of power they produce, expressed in watts or kilowatts (1000 watts). An AC generator rated at 75000 watts or 7.5 kilowatts was used. The details of the Engineering drawings of PTO operated electricity generation system is shown in the Appendix.

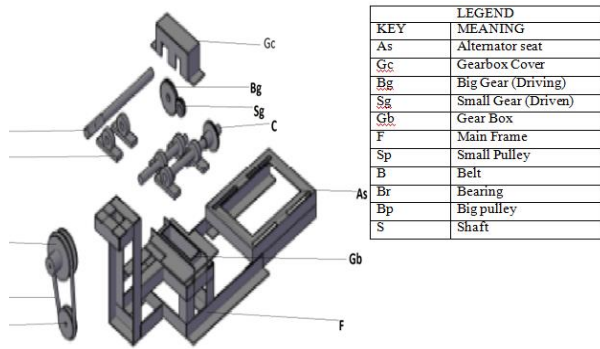

Fig. 1: Part drawing of the machine parts



Fig. 2: Completed PTO Actuated electricity generation system connected to the tractor



Fig. 3: The testing process of the machine

Machine working principle

The mechanical power generated at the PTO shaft of the tractor was utilized through pulley and gear system arrangement. The pulley arrangement is made of two pulleys connected via a belt. The power is transmitted from the larger pulley attached to the tractor PTO shaft to the smaller pulley coupled to a gear system, thereby increasing the rotational speed of the shaft. The power was further transmitted from the larger gear that was coupled to the axis of the smaller pulley to smaller gear that was couple to the alternator input shaft. The final speed of the alternator was sufficient to rotate the rotor of AC generator. As the rotor of the AC generator rotate at high speed the alternator convert the mechanical power of the tractor to electric power as shown in Fig. 3. This power can utilize on the farm by the farmers for various electrical farm activities.

Design assumptions

The following assumptions presented in Table 1 were made in the design of the machine components as the system was designed mainly for electricity generation from tractor PTO shaft.

Table 1: Assumed values used in the design

S/N	Parameter	Value
1	Expected output voltage	220-240 volts
2	Frequency of the voltage	50 hertz
3	Number of driving gear teeth	30 teeth
4	Number of driven gear teeth	15 teeth
5	Diameter of driving pulley	250 mm
6	Diameter of driven pulley	150 mm
7	Type of belt	V-belt
8	Expected power output	5 kW
9	PTO Power	40kW

Design calculations

Fundamental design analysis and calculations were carried out in order to determine and select materials of appropriate strength and sizes for the machine component parts.

Determination of alternator size

For a typical farm, two or three lists of equipment may need to be operated simultaneously. For this work based on the load to be imposed on the system and for flexibility of the system, a 7 kW (75000 watts) alternator was selected.

Determination of output current

The output current to be generated from the alternator power rating was obtained from the following mathematical expression as reported by Abouelela and Al-Mashary (2005) and is given as;

$$P = IV \tag{1}$$

Where: P is power in watts, I is current in amperes, (A), V is voltage in volts, (V)

Determination of resistance

The resistance offered to the current generated was obtained as reported by Abouelela and Al-Mashary (2005) and is given as;

$$R = \frac{V}{I} \tag{2}$$

Where: R is resistance in ohms, (Ω), V = voltage in volts, (V), I is current in amperes (A)

Determination of driven pulley

In order to achieve the expected working speed of the alternator, the drive pulley was selected. Therefore, the diameter of the driven pulley was determined using the relation given Khurmi and Gupta, (2005):

$$d_{p2} = \frac{N_1 \times d_{p1}}{N_2} \tag{3}$$

Where: d_{p2} is diameter of driven pulley (m), d_{p1} diameter of driving pulley (m), N_1 is speed transmitted to driving pulley (rpm), N_2 is output speed (rpm).

Determination of length of the belt

The length of the belt connecting the PTO shaft to the gearbox of connected directly to the alternator was determined as reported by Khurmi and Gupta, (2005);

$$L_b = \frac{\pi}{2} (d_{p1} + d_{p2}) + 2x + \frac{(d_{p1} - d_{p2})^2}{4x} \tag{4}$$

$$C = \frac{d_{p2} + d_{p1}}{2} + d_{p1} \tag{5}$$

Where: L_b is length of the belt (m), d_{p1} is diameter of the driving pulley (m), d_{p2} is diameter of the driven pulley (m), x is centre distance between the two pulleys in (m), d_{p1} diameter of driving pulley (m) is, d_{p2} is diameter of driven pulley (m).

Determination velocity of the belt

In order to determine the centrifugal force exerted on the belt, the speed of the belt was determined as reported by Khurmi and Gupta, (2005);

$$V_b = \frac{\pi d_1 N_1}{60} \tag{6}$$

Where: V_b is velocity ratio of the belt drive in (m/s), d_{p1} is diameter of the driving pulley (m), N_1 is speed of the driving pulley (rpm).

Determination of angle of contact between the belt and pulley

The angle of contact between the belt and the two pulleys was determined in order to know the tension built up between the belt and the pulleys. It was computed as reported by Khurmi and Gupta (2005), and is given as;

$$\theta = (180^\circ - 2\alpha) \times \frac{\pi}{180} \quad (7)$$

But, $\alpha = \sin^{-1} \frac{(r_1 - r_2)}{x}$ (8)

Where: θ is angle of contact between the belt and pulley, r_1 is radius of the driving pulley (m), r_2 is radius of the driven pulley (m), x is the centre distance between the two pulleys (m),

Determination of the belt tension

The tension developed in the belt was evaluated in order to know the power transmitted by the tractor PTO. It was computed as reported by Khurmi and Gupta (2005), and is given as;

$$K = 2.3 \log \frac{T_1}{T_2} = \mu \times \theta \times \operatorname{cosec} \beta \quad (9)$$

Where: T_1 is tension in the tight side of the belt (N), T_2 is tension in the slack side of the belt in (N), β is average groove angle of the shaft pulley, θ is angle of constant or lap between the two pulleys, μ is coefficient of friction between the belt and the pulleys

For an oak tanned leather belt on cast iron pulley at the point of slipping, the coefficient of friction between the belt and cast iron pulley was determined as reported by Khurmi and Gupta, (2005) and is given as

$$\mu = 0.54 - \frac{42.6}{152.6 + V_b} \quad (10)$$

Where: V_b is speed of the belt (m/s),

Also the torque transmitted by the pulley shaft was computed as reported by Khurmi and Gupta, (2005), and is given as

$$T = (T_1 - T_2) \times r_2 \quad (11)$$

$$T_1 = \frac{T}{r_2} + T_2 \quad (12)$$

Where: T is torque of the driven shaft (Nmm), T_1 is tension in the tight side of the belt (N), T_2 is tension in the slack side of the belt (N), r_2 is radius of the driven pulley (mm)

Determination of power transmitted by the belt

This was done in order to know the amount of energy transmitted from the tractor to the gear system. It was determined using the equation by Khurmi and Gupta, (2005):

$$P = (T_1 - T_2) \times V \quad (13)$$

Where: P is power transmitted by the belt (watts), T_1 is tension in the tight side of the belt (N), T_2 is tension in the slack side of the belt (N), V is velocity of the belt in (m/s).

Determination of gear ratio

The velocity ratio of the gear system was determined as reported by Khurmi and Gupta (2005), and is given as;

$$V_r = \frac{G_T}{P_T} \quad (14)$$

Where: V_r is the velocity ratio, G_T is Number of teeth of the gear, P_T is Number of teeth of the gear pinion

Determination of shaft diameter

The diameter of the central shaft was computed using the equation reported by Khurmi and Gupta (2005);

$$d^3 = 16/\pi S_s \sqrt{(K_b M_b)^2 + (K_t M_t)^2} \quad (10)$$

where, d = expected diameter of shaft(m), M_t is belt torque moment (Nm), M_b is bending moment (Nm), K_b is shock and fatigue factor applied to bending moment,

K_t is shock and fatigue factor applied to torsional moment, S_s is permissible shear stress of the shaft

i. Shaft used between tractor PTO and bigger pulley, (Shaft A): Tractor PTO power at 540 rpm is 45 kW (Ajit *et al.*, 2006), speed of the shaft, $N_1 = 540$ rpm, Shear stress for shafts without allowance for key ways, $\tau = 56$ MPa (Khurmi and Gupta, 2005).

Power transmitted to the shaft was taken to be 40 kW due to other indirect forces acting on it such as friction.

ii. Shaft diameter used between smaller pulley and pinion, (Shaft B): Power transmitted, $P = 40$ kW, Speed transmitted to pulley, $N_2 = 900$ rpm, Maximum permissible shear stress, τ for shaft without allowance of keyway is 56Mpa or 42 N/mm²

iii. Shaft diameter used between gear and alternator, (Shaft C): Power transmitted, $P = 40$ kW, Speed transmitted to pulley, $N_3 = 1800$ rpm, Maximum permissible shear stress, τ for shaft without allowance of keyway is 56 Mpa

Determination of maximum working stress of the shaft

This was done in order to know the strength of the shaft and its behavior under working condition. It is determined as reported by Khurmi and Gupta (2005), and is given as

$$\sigma = \frac{16T_s}{\pi d^3} \quad (11)$$

Where:

σ is maximum permissible working stress, d is shaft diameter (m) T_s is Torque of shaft (Nm)

Machine testing procedure

A universal connector was fixed into the splines of the tractor at one end and also connected to the splines of the pulley arrangement system shaft. Electric bulb of 100W and Hand iron filing machine 2100W were connected to the system in order to ascertain whether the system could generate current and to know the strength of the generated voltage, current and resistance, as shown in Fig. 3. The system was tested at five different rotor speeds of 900, 1100, 1300, 1500 and 1800 rpm in order to determine the amount of current, and voltage generated by the system as well as the resistance. The result obtained is presented in Figs. 4 to 6 and Appendix 2.

Results and Discussion

Effects of speed on output voltage

The effects of alternator speeds on the output voltage indicated that increasing the speed from 890 to 1800 rpm increased the output voltage from 120 V to 220 V (Fig. 4). This could be due to increase in energy generated associated with higher speed of the alternator. This is in agreement with results of similar studies conducted by Ruben *et al.* (2012) where alternator speed and size are key factors that affect the efficiency and voltage generated.

A significant effect was observed in the output voltage with increasing speed of rotation from 900 rpm to 1800 rpm. However, almost constant voltage output was observed between speed of 1500 rpm (208 V) and 1800 rpm (220 V).

Effects of speed on current

The effects of alternator speeds on the output current indicated that increasing the speed from 890 to 1800 rpm increased the output current from 12.5 A to 33.7 A as shown in Fig. 5. Similarly, this could be due to increase in energy generated associated with higher speed of the alternator. This is in agreement with results of similar studies conducted by Ruben *et al.* (2012) where alternator speed and size are key factors that affect the current output and power generated in the alternator.

A significant effect was observed in the output current with increasing speed of rotation from 900 to 1800 rpm. But almost constant current output was observed between speed of 1500 rpm (33.7 A) and 1800 rpm (34).

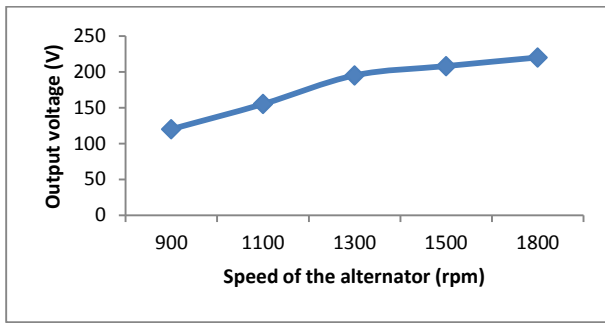

Fig. 4: Effects of alternator speed on the output voltage

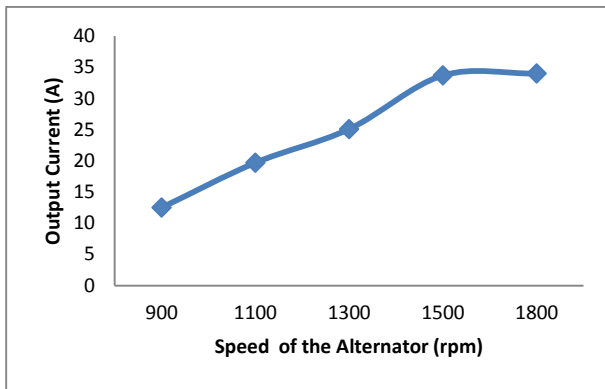

Fig. 5: Relationship between speed and current generated

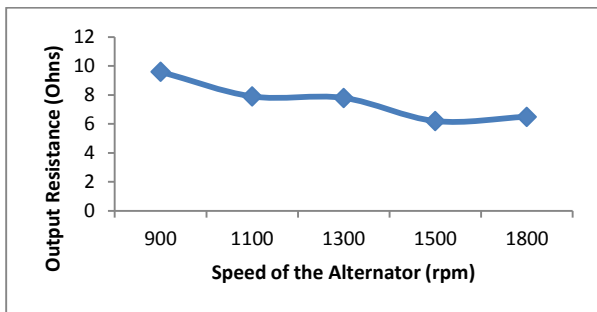

Fig. 6: Relationship between speed and voltage resistance

Effects of speed on voltage resistance

The effects of alternator speeds on the voltage resistance indicated that increasing the speed from 890 to 1800 rpm decreases voltage resistance from 9.6 to 6.5 Ω. as shown in Fig. 6. This could be due to the high energy generated by the higher speed of the alternator which overcomes the voltage resistance offered.

However, voltage resistance was observed to be almost constant at alternator speeds between 1500 rpm (6.2 Ω) and 1800 rpm (6.5 Ω).

Conclusion

A system for generation of electricity from tractor PTO shaft was developed and tested. Test results of the system using five

different rotor speeds of 900, 1100, 1300, 1500 and 1800 rpm indicated both output voltage and current generated increased with increase in speed of rotation while the resistance offered decreases with increase in speed. The highest and most desirable output voltage and current of 220 V and 34 amps were obtained from speed of 1,500 rpm to 1800 rpm whereas lowest output voltage of 120 V and current of 12.5 amps were obtained from speeds of 900 to 1,100 rpm. On the other hand highest resistance of 9.6 (Ω) was observed from speed of 900 rpm whereas low resistance of 6.5 (Ω) was obtained at a speeds of 1500 to 1800 rpm. The equipment is easy to use, demands less effort and easy to dismantle and assemble.

References

Abdullah MO, Lim SF, Salleh SF, Tai1 TM, Leo SL & Umar AK 2012. Development of a small-scale reactor system for bioethanol production from agriculture waste geared towards small industries applications in Malaysia. *IOSR Journal of Engineering (IOSRJEN)*, 6(2): 1321 – 1327.

Adewumi IO 2015. Automatic Voltage Regulator (AVR) Design for Fuelless Generating Set, Proceeding of International Conference of Nigerian Institute of Industrial Engineers, Held at University of Ibadan Hotel and Conference Center Ibadan Nigeria, 26.

Adewumi IO 2014. Design, Construction and Performance Evaluation of 1KVA Fuel less Being an Unpublished M.Sc Thesis, Submitted to the Department of Agricultural and Environmental Engineering, Faculty of Technology, University of Ibadan Nigeria, p. 3.

David JCM 2009. *Sustainable Energy-Without the Hot Air*, publisher: UIT.

Dyer JA & Desjardins RL 2006. An integrated index of electrical energy use in Canadian agriculture with implications for greenhouse gas emissions. *Biosystems Engineering, Elsevier*, 95(3): 449–460

Khurmi, R.S., and Gupta J.K. 2005. Machine Design. First Multicolour Edition. Enrasia Publishing House (PVT) Ltd. Ram Nagar, New Delhi-110 055

Gana IM, Agidi G, Idah PA & Anuonye JC 2017. Development and testing of an automated grain drinks processing machine. *Journal of Food and Bioproducts Processing, Elsevier*, 1(4) 19–31 www.elsevier.com/locate/fbp

Meta Economics Consulting Group Pty Ltd 2013. Electricity Supply Issues for Farmers Report to the Consumer Advocacy Panel A.B.N. 50 143 853 123, <http://energyconsumersaustralia.worldsecuresystems.com/grants/442/AP-442-Meta-Economics-Farmers-electricity-supply-report.pdf>

Randy S 2004. Energy Use in Agriculture: Background and Issues Congressional Research Service~The Library of Congress Order Code RL32677 <http://nationalaglawcenter.org/wp-content/uploads/assets/crs/RL32677.pdf>

Appendix 1: Engineering Drawings of PTO Operated Electricity Generation System

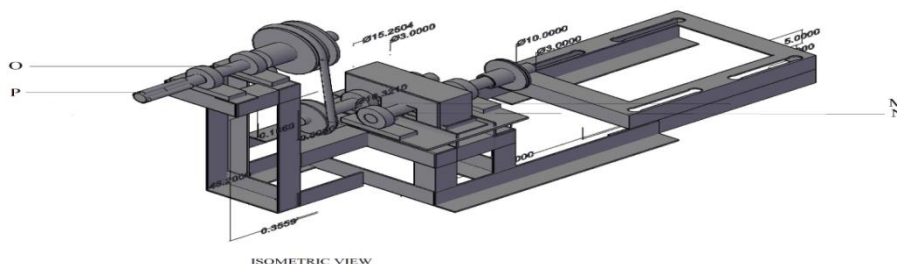

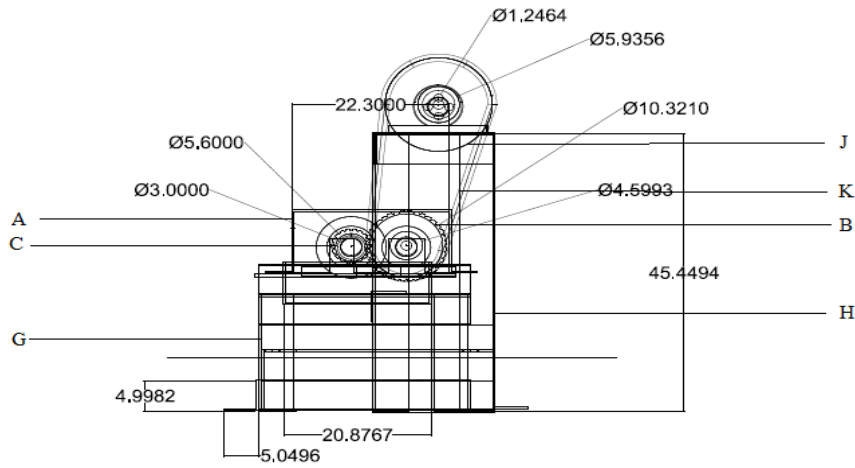

LEFT HAND SIDE VIEW

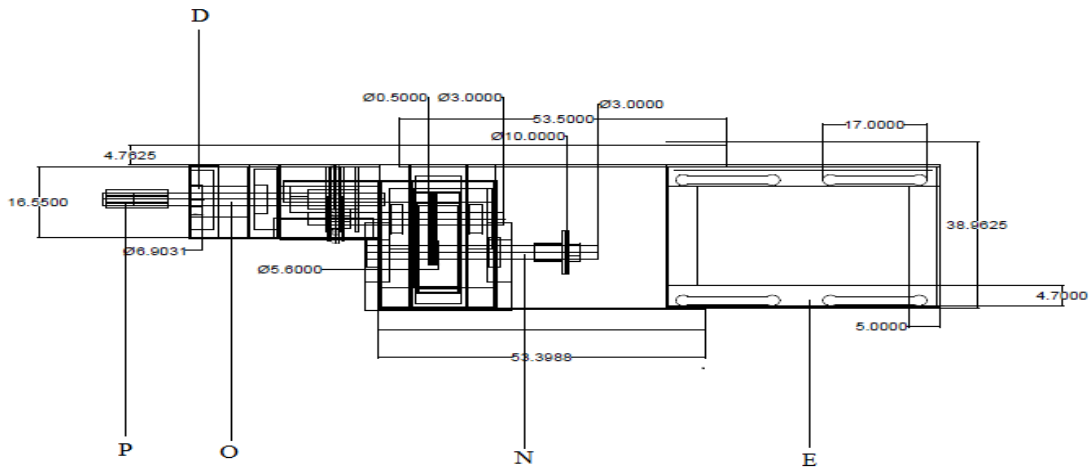

TOP VIEW

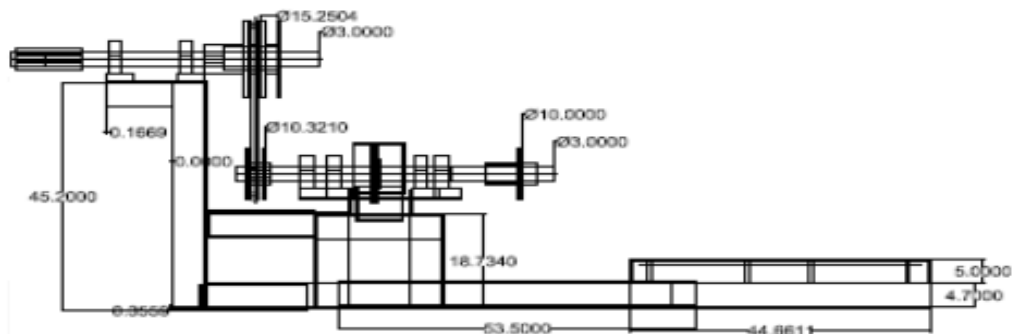

FRONT VIEW

Legend

ABBREVIATION	MEANING
A	Gearbox Cover
B	Big Gear (Driving)
C	Small Gear (Driven)
D	Bearing