

Simulation of a Wet Cylinder Liner

Sunday Bako^{1*}, Thomas Usman¹, Ige Bori², Abdulkarim Nasir²

¹Department of Mechanical Engineering, Nuhu Bamalli Polytechnic, Zaria, Nigeria

²Department of Mechanical Engineering, Federal University of Technology, Minna, Nigeria

Abstract

This paper presents modeling and simulation of automobile engine wet-cylinder liner. The wet-cylinder liner is a cylindrical vessel in which the piston makes a reciprocating motion. Its function is to retain the working fluid and to guide the piston. The cylinder liners are subjected to high structural and thermal stress which leads to its deterioration and engine failure. This paper aimed at investigating the impact of this structural and thermal stress acting on the cylinder liner. Structural and thermal simulation was carried out using Solidworks (2013) software. The simulation result shows that the wet-cylinder liner is subjected to harmonic vibration during the engine operation due to the stresses acting on it. This vibration leads to the formation of vapour bubbles in the water jacket of the engine which leads to cavitation. This hammering and explosive effect (cavitation) of these bubbles on the cylinder liner is the main causes of pitting and corrosion on the cylinder liner. The steady state and transient thermal analysis shows that the convective cooling of the cylinder liner decreases inversely with time and this leads to accumulation of heat in the automobile engine. This accumulated heat energy is the major causes of high frictional wear, cracking of the cylinder liner and other thermal problems of the engine. However, the simulation results shows that the wet-cylinder liners are subjected to structural and thermal failure, if detailed design and material selection are not properly carried out.

Keywords - Wet-cylinder Liner Modeling and Simulation.

I. INTRODUCTION

Cylinder liners are cylindrical component that are placed inside the engine block of an automobile engine. It is an important component that gives a wear protective surface for the piston and the piston rings. Its function is to retain the working fluid and to guide the piston [1]. The cylinders are usually made from cast iron or cast steel. Other important function of cylinder liner is to form a sliding surface, to transfer heat and to compress gases in the engine [2]. The cylinder liners have to withstand high pressure and temperature due to fuel combustion, therefore some arrangement are made to cool the cylinders. Multi cylinder engines are provided with water jacket round the cylinder to cool it. The cylinder liners are of two types. A cylinder liner which does not have any direct contact with the coolant is known as dry cylinder

liner. A cylinder liner which have it outer surface in direct contacted with the coolant is known as wet-cylinder liner [2].

Wet cylinder liner does not have an integral cooling passages; the water jacket is formed by the liner and a separate jacket which is a part of the block (See Figure 1.). A static seal is provided at both the combustion and crankshaft ends of the cylinders to prevent the leakage of coolant into the engine oil and into the combustion chamber [3].

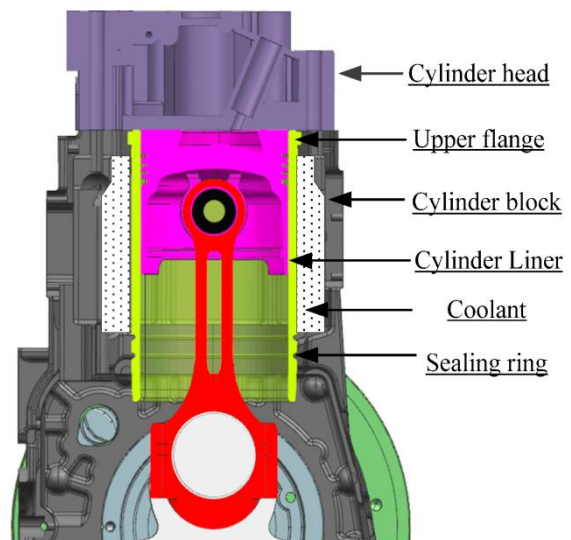

Fig 1: Cylinder Liner Arrangement [4]

A. Qualities of Cylinder Liner

The automobile engine cylinder liner should have the following qualities;

- i. Strength to resist the gas pressure
- ii. Sufficiently hard to resist wear
- iii. Strength to resist the thermal stresses due to the heat flow through the liner wall
- iv. Anti-corrosive property
- v. Capable of taking a good bearing surface
- vi. Should be symmetrical in shape to avoid unequal deflection due to gas load and unequal deflection due to thermal load
- vii. No distortion of inner surface due to restraining fixings.

In-line with [5], Liner damage is usually well defined and occurs primarily within the band extending from the top to the bottom of the liner on the thrust side and that it sometimes occurs on the anti-thrust side. Pitting can penetrate the liner wall until perforations go all the way through to the combustion chamber, thereby causing complete

knock down of the automobile engine. This paper is concerned with structural and thermal analysis of wet-cylinder liner. The wet cylinder liners are subjected to failure such as wall crack, excessive wear, corrosion and pitting. The paper aimed at carrying out modeling and simulation of the wet cylinder liner and to investigating the impact of structural and thermal loads acting on the wet cylinder liner.

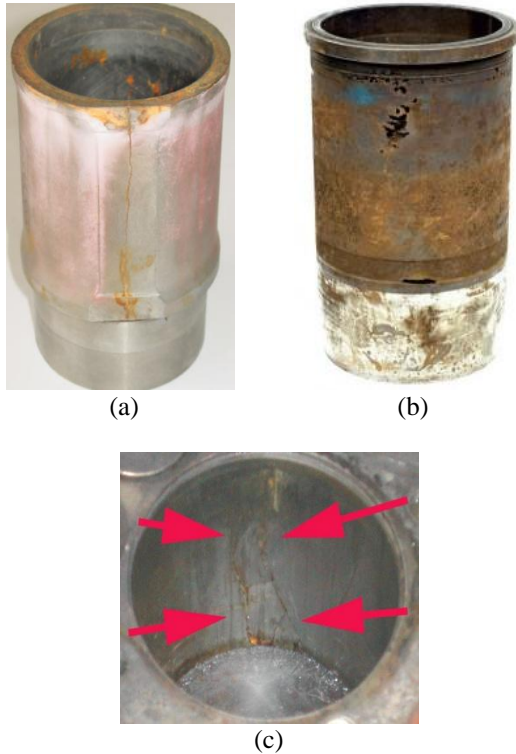

Fig 2: Infected Wet Cylinder Liner (a). Liner Crack (b). Liner Corrosion and Pitting. (c). Liner Frictional Wear

II. MATERIALS AND METHODS

The materials used in this analysis includes; Solidworks (2013) simulation package and a model of a wet cylinder liners. The properties of the cylinder liner material (cast iron) used in this analysis are shown in Table 2 below. In this paper, Solidworks modeling and simulation methodology has been employed to develop and analyse the impact of structural and thermal stress acting on the wet cylinder liner model. During the thermal analysis, both steady state and transient thermal analysis were conducted. Figure 3.0 shows the summary of the simulation process.

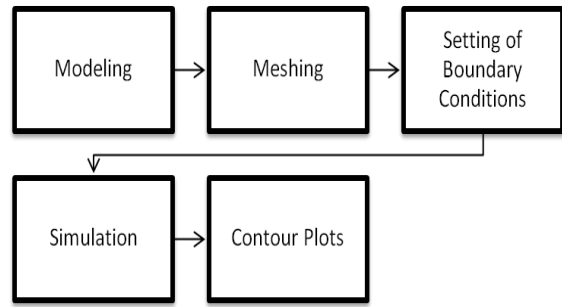

Fig 3: Simulation Process

A. Engine Specification

The engine, whose wet cylinder liner was used in the analysis, has the following specifications;

- i. Engine Code- XM7
- ii. Fuel Used- Petrol
- iii. Fuel System- Carburetor Solex (BICSA)
- iv. Bore x Stroke- 84.0 x 81.0
- v. Number of Valve- 8 Valves
- vi. Compression Ratio- 7.5:1
- vii. Power Output- 59kW (at 5000rpm)
- viii. Maximum Torque- 140Nm (at 2500rpm)

B. Cylinder Liner Nomenclature

The cylinder nomenclature shows the various parts of the cylinder liner and their names. Some wet cylinder liners have flange just above the spigot as shown in Figure 2 (a) and Figure 4 respectively. The wet cylinder liner nomenclature is shown in Figure 4 below;

- i. A-Flange Depth
- ii. B-Flange Diameter
- iii. C-Outer Diameter
- iv. D-Inside/Bore Diameter
- v. E-Spigot Diameter
- vi. F-Spigot Length
- vii. G-Overall Length
- viii. H-Height of Cylinder Liner

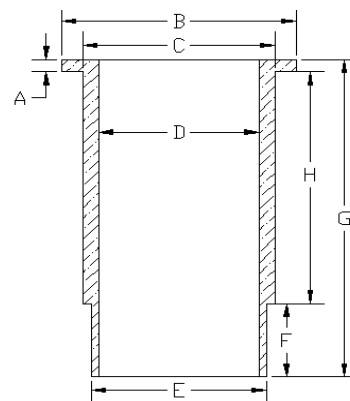

Fig 4: Cylinder Liner Nomenclature

C. Cylinder Liner Design

The engine cylinder liner is subjected to gas pressure and piston side thrust. This produces longitudinal and circumferential stress. The apparent longitudinal (σ_l) stress is given by;

$$\sigma_l = \frac{\frac{\pi}{4} \times D^2 \times P}{\frac{\pi}{4} (D_o^2 - D^2)} = \frac{D^2 \cdot p}{(D_o^2 - D^2)} \quad (1)$$

The apparent circumferential (σ_c) stress is given by;

$$\sigma_c = \frac{D \times l \times p}{2t \times l} = \frac{D \times p}{2l} \quad (2)$$

Where;

D_o = Outside diameter of the cylinder (mm)

D = Inside diameter of the cylinder (mm)

P = Maximum pressure inside the engine cylinder (N/mm²)

t = Thickness of the cylinder (mm)

The thickness of a cylinder wall (t) is usually obtained by using the thin cylinder formula as;

$$t = \frac{p \times D}{2\sigma_c} + C \quad (3)$$

Where;

C = Allowance for re-boring

The thickness of the water jacket wall (t_j) is given by;

$$t_j = 0.032D + 1.6mm \quad (4)$$

The water space between the outer cylinder wall and inner jacket wall (t_s) is given by;

$$t_s = 0.08D + 6 \quad (5)$$

The length of the stroke (l) is taken as;

$$l = 1.25D \sim 2D \quad (6)$$

Since there is a clearance on both sides of the cylinder, therefore the length of the cylinder (L) is taken as 15 percent greater than the length of the stroke. In other word;

$$L = 1.15l \quad (7)$$

The power produced inside the engine cylinder known as indicated power ($I.P$) is given by,

$$I.P = \frac{P_m \times l \times A \times n}{60} mm \quad (8)$$

Where,

P_m = Indicated mean effective pressure (N/mm²)

A = Cross-sectional area of the cylinder in (mm²)

n = Number of working strokes per minutes [6].

D. Cylinder Liner Modeling

The first step in this analysis was to prepare a solid model of the wet cylinder liner model. The models were developed using Solidworks (2013) package. The model is shown in Figure 4. The cylinder liner models have the following specification.

Table 1: Models Specification

S/N	Parameter	Value	Unit
1	Flange Depth	10.00	mm
2	Flange Diameter	99.20	mm
3	Outer Diameter	93.00	mm
4	Inner Diameter	84.00	mm
5	Spigot Diameter	93.00	mm
6	Spigot Length	46.17	mm
7	Cylinder Height	90.03	mm
8	Overall Length	136.20	mm

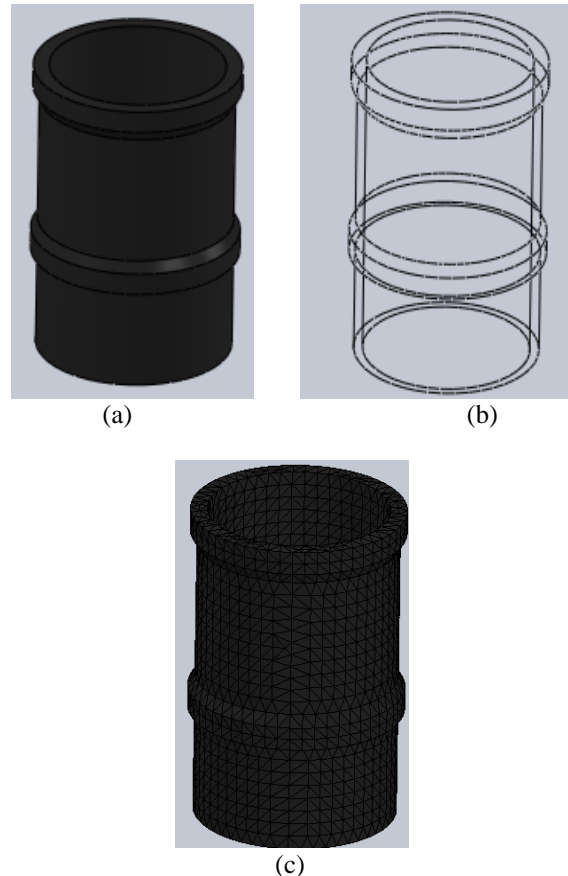

Fig 5: (a) Solid Model (b) Wire Frame Model (c) Meshed Model

III. SIMULATION ANALYSIS

In this analysis, Solidworks simulation methodology has been employed to investigate the impact of forces and thermal stress acting on the wet cylinder liner. The exterior and the interior temperature of the cylinder liner were assigned to be 400°C and 2227°C respectively. The maximum compression pressure is assigned to be 20bar. In simulating the models, the following boundary

conditions and specifications of the cylinder liner material (gray cast iron) were taken into account as shown in Table 2.

Table 2: Material Specifications and Properties

S/N	Property	Value	Unit
1	Elastic Modulus	6.61781e+010	N/m ²
2	Poisons Ratio	0.27	N/A
3	Shear Modulus	5e+010	N/m ²
4	Density	7200	Kg/m ³
5	Tensile Strength	15165800	N/m ²
6	Compressive Strength	578572165000	N/m ²
7	Thermal Expansion Coefficient	1.2e-005	/K
8	Thermal Conductivity	45	W/mK
9	Specific Heat	510	Kg.K
10	Liner Maximum Pressure	20	Bar
11	Liner Exterior Temperature	400	◊C
12	Liner Interior Temperature	2227	◊C

A. Contour Plots

After the running the structural, the steady state and transient thermal analysis on the wet cylinder liner, the simulation results were presented in form of contour plots as shown Figure 5 below.

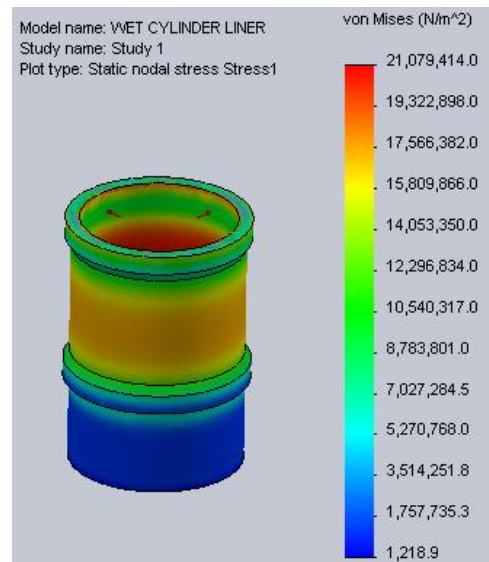

Fig 7: Von Miss Stress

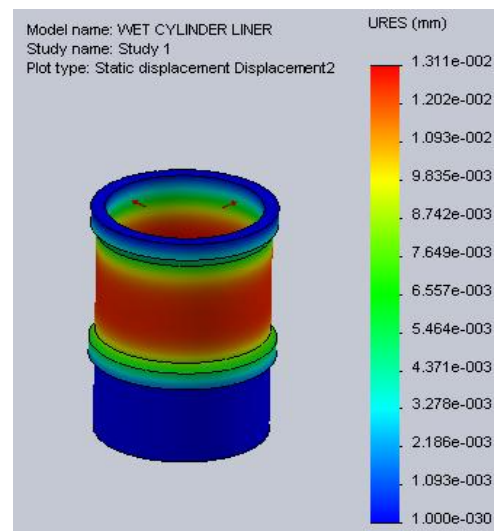

Fig 8: Displacement

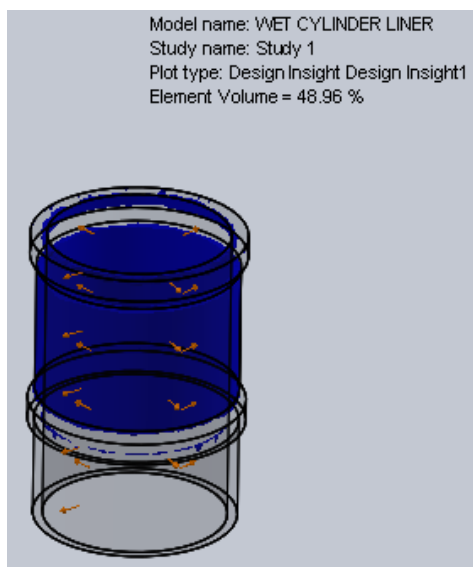

Fig 6: Design Insight

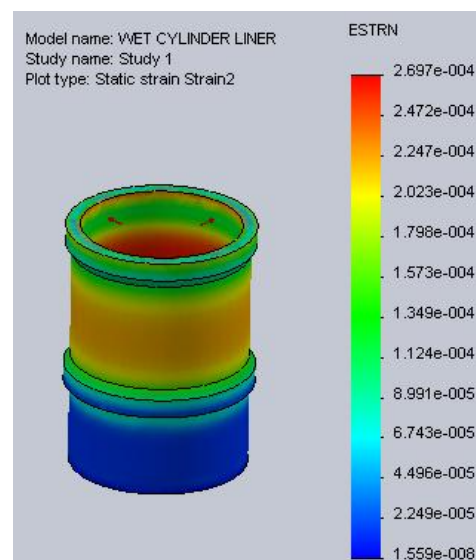

Fig 9: Strain

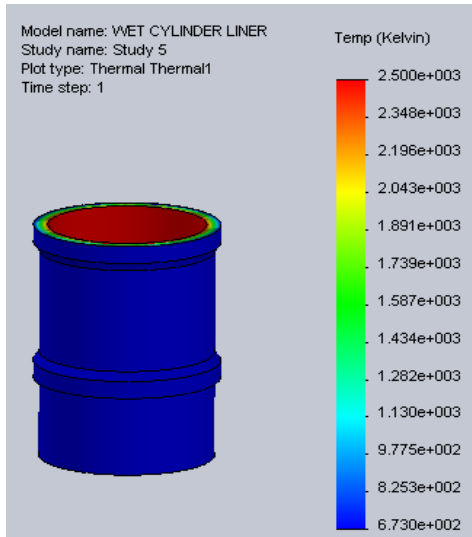

Fig 10: Steady State Thermal Analysis Temperature Distribution

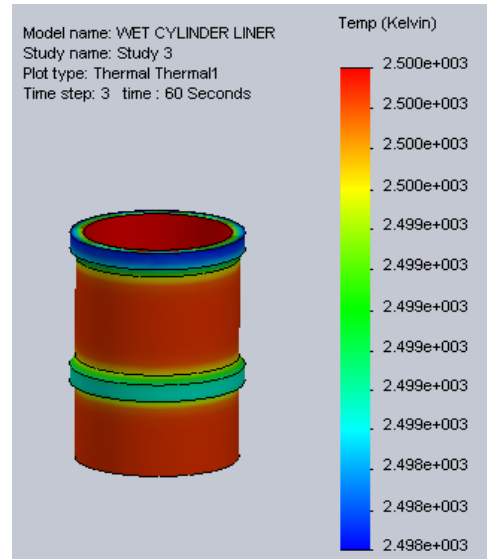

Fig 13: Temperature Distribution after 80 Seconds

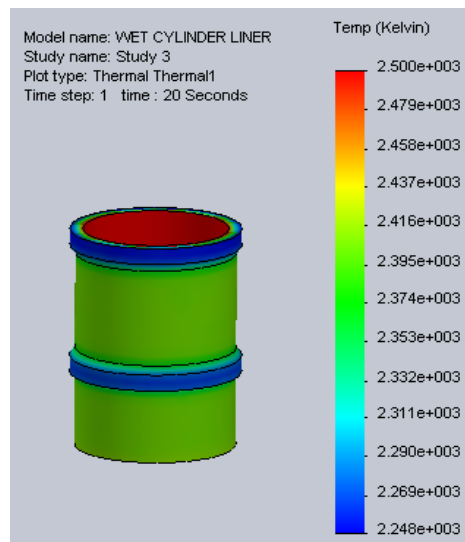

Fig 11: Temperature Distribution after 20 Seconds

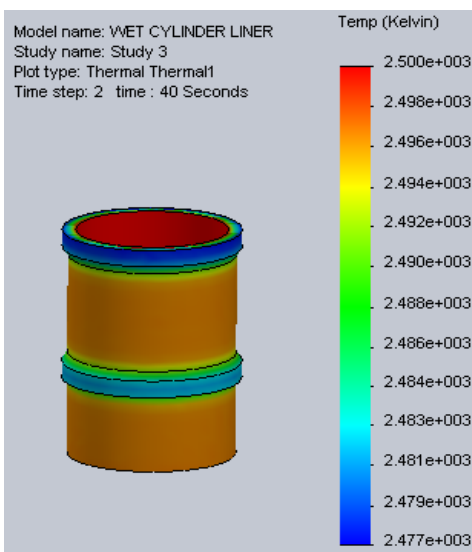

Fig 12: Temperature Distribution after 40 Seconds

IV. DISCUSSION OF RESULTS

The Solidworks design insight (Figure 6) show the region of the wet cylinder liner that is subjected high load impact. The simulation plots (Figure 6.-13) shows the prediction of the structural stress, displacement, strain and thermal stress acting on the wet cylinder liner during the working operation of the engine. The plots show that the maximum stress, displacement, and strain occur between the flange diameter and the spigot diameter. Before deforming the wet cylinder liner model to its original shape; its shape appears as shown in the first figure of Figure 14. During the animation process, the wall of the cylinder liner was found to be vibrating as illustrated in Figure 14. The animation and the simulation plots show that the maximum stress, displacement, and strain occur between the flange diameter and the spigot diameter. This justified the work done by [4], which states that, Liner damage usually occurs between the bands extending from the top to the bottom of the liner on the thrust side. As the results of the harmonic vibration of liner wall; the region directly below flange and above the spigot diameter would be the major region subjected to high wet cylinder deterioration.

The animation analysis shows that when the engine is under operation; the cylinder liner exerts pressure mostly during the compression and power stroke of the engine. This makes the liner wall to undergo harmonic vibration, due to the action of the pressure inside the cylinder. When the liner returns to its original shape, the water cannot follow quickly enough. As a result, small vapour bubbles are formed at the wall of the liner. When the cylinder liner stops moving, these vapour bubbles collapse violently. This impact leads to fluid hammering infect known as cavitation. Due to this harmonic vibration of the liner wall during the engine operation; the region directly below and above the flange and spigot diameter

exposed to deterioration like cracking, pitting and corrosion which is justified by Figure 2.

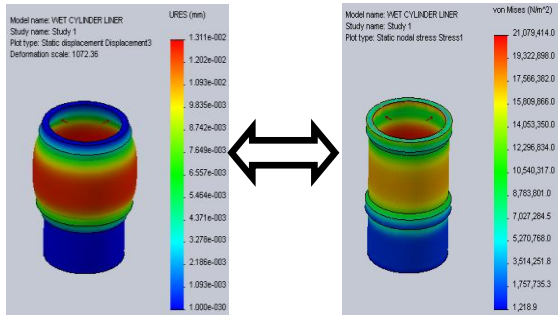

Fig 14: Cylinder Liner Animation

The volumetric, thermal efficiency and power output of an engine decreases with an increase in cylinder temperature [7]. The transient thermal analysis shows that the temperature of the wet cylinder liner increases with time. This increased in temperature of the cylinder liner, also increases the temperature of the cooling water in the cooling system. Due to the inability of the cooling system to effectively cool the outer surface of the cylinder liner; favours the continuous accumulation of heat in the automobile engine. This reduces the convective cooling of the cylinder liner by the engine cooling system. This accumulated heat energy in the engine cylinder is the major causes of the following automobile engine problems;

- i. Pre-ignition
- ii. Loss of lubricating power of the engine oil
- iii. Breaking of piston rings due to high thermal expansion
- iv. Engine over heating
- v. High frictional wear of the engine components

V. CONCLUSION

Modeling and simulation of automobile wet-cylinder liner has been carried out. The simulation result shows that the wet cylinder liner is subjected to harmonic vibration during the engine operation. This implies that the cylinder liner is subjected to structural and thermal stress during the compression and expansion stroke of the engine. This harmonic vibration leads to the formation of vapour bubbles in the water jacket which leads to cavitation. This hammering and explosive effect of these bubbles (cavitation) on the cylinder liner is the major causes of pitting and corrosion of the cylinder liner. The transient thermal analysis shows that the convective cooling of the cylinder liner decreases inversely with time and this leads to accumulation heat in the automobile engine. This accumulated heat is the major causes of high frictional wear and cracking of the cylinder liner and other thermal problems associated with automobile engines

It is hereby call on automobile engine designers to take critical measures in designing of automobile cylinder liner, water jacket and the entire cooling system, in order to improve the strength of the cylinder liner and to improve the cooling of the engine. It is therefore recommended that the following parameters should critically be taken into account during the cylinder design;

- i. The maximum pressure that would be develops during the compression stroke.
- ii. The maximum pressure that would be absorb by the cylinder wall during the expansion stroke.
- iii. Thermal expansion and conductivity of the cylinder liner material.
- iv. The maximum thermal stress that would develop on the cylinder wall during the compression and expansion stroke.
- v. The maximum circumferential and longitudinal stress that would be acting on the cylinder wall.

REFERENCE

- [1] R.S. Khurmi and I.K. Gupta. A Text Book of Machine Design. 14th Reprint. Eurasia Publishing house (Pvt) Ltd. 2004
- [2] M.F. Ahmad, A. Fakaruddin1, M. Hafiz1 and K. Karmegam (2012). Materials Selection for Wet Cylinder Liner. Journal Of Engineering (Iosrjen) 2 (9), 23-32.
- [3] K. Srinivasa Rao, K. Srinivas, B. Vinay, D. Aditya, K.V Vamsi Krishna, and K. S. R. Krishna. Analysis Of Engine Cylinder Liners. International Research Journal of Engineering and Technology. Vol. 02 Issue 09, Pp 631-640. 2015
- [4] G. li, F. Gu, T. Wang, J. You and A. Ball. Investigation into the Vibration Responses of Cylinder Liner in an IC Engine Fueled by Biodiesel. Applied Sciences. Vol. 7 Issue 717) Pp1-24. 2017.
- [5] Y. K. Zhou, J. G. He, F.G. Hammitt. Cavitation Erosion Of Diesel Engine Liners. W.E Lay Automotive Laboratory, Department of Mechanical Engineering and Appkied Mechanics, College of Engineering, North Campus, Unversity of Michingam Ann Arbor, Mi 48109 (USA). 1981.
- [6] P.C. Sharma and D.K Aggarwal. Machine Design. Eleventh edition. S.K. Kataria & Son. 2006.
- [7] A.K Raja, P. Anit, and M. Dwivedi. Power Plant Engineering. New International Limited Publisher. 2006.