

## Delineation of Time-Stratigraphic Units on Open-Hole Geophysical Logs Acquired In Etsako Field, Onshore Niger Delta of Nigeria

Christopher Imoukhai Unuevho<sup>1</sup>, Mojeed Mohammed Tokurah<sup>2</sup>,  
Emmanuel Emeka Udensi<sup>2</sup>

<sup>1</sup>Department of Geology, Federal University of Technology, Minna, Nigeria

<sup>2</sup>Department of Physics, Federal University of Technology, Minna, Nigeria

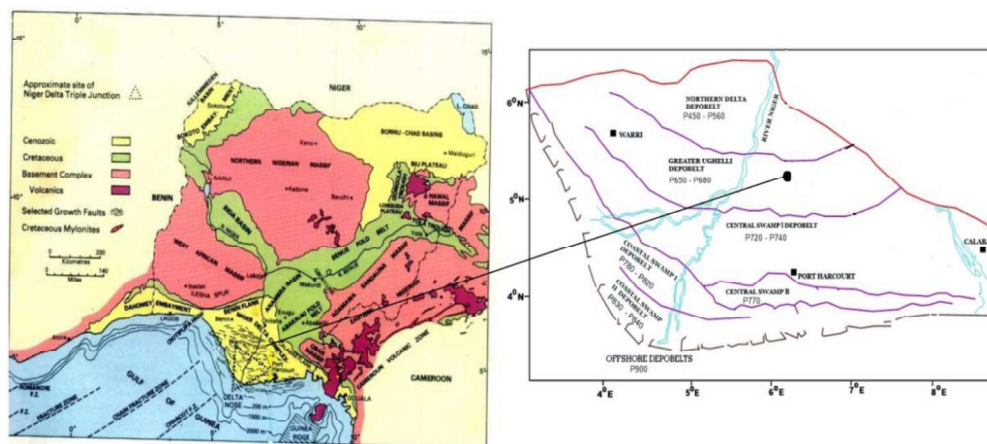
**Abstract:** Etsako Field remains in appraisal phase since hydrocarbon is yet to be produced from it. Lithostratigraphic technique was earlier employed to subdivide and correlate sedimentary sequence penetrated within the field. The technique often results in exaggerated reservoir continuity and concomitant drilling of dry step-out and infill wells. ET2, ET4, and ET5 are dry step-out wells drilled in the field after ET1 (discovery well) and ET3 (successful or wet well). Parasequences and parasequence sets were employed in this study to generate a time stratigraphic framework for the field. Depth structure maps were produced from depth of sands' top obtained within the time stratigraphic framework. Progradational and retrogradational parasequence sets were identified. Two unconformity and maximum flooding surfaces were delineated. Hydrocarbon reservoir sands in ET1 and ET3 are Sands I and M, while those in ET6 are sands B and F2. Sands B and M were found in lowstand systems tracts (LST), while sands F2 and I were found in highstand systems tracts (HST). Sand B's depth structure map revealed infill wells will penetrate hydrocarbon bearing portion of the sand within longitudes 6.785°E to 6.786°E and latitudes 5.634°N to 5.638°N. Sand M's depth structure map revealed opportunity for wet infill wells within longitudes 6.770°E to 6.7862°E and latitudes 5.632°N to 5.638°N. Infill wells should be drilled beyond present depth of 10000ft to test deeper LST and HST within the field.

Date of Submission: 09-04-2018

Date of acceptance: 23-04-2018

### I. Introduction

Etsako Field is an onshore field discovered before the 1990s within eastern part of Nigeria's Tertiary Niger Delta basin called Greater Ughelli Depobelt (figure 1).



**Figure 1:** Greater Ughelli Depobelt within which Etsako Field is located in Niger Delta basin (Modified after<sup>1</sup>)

Though five wells (ET1, ET2, ET3, ET4, ET5, and ET6) have been drilled in the field, no hydrocarbon has been produced from it. This implies that the field is still in its appraisal phase. An essential aspect of field appraisal is ascertaining reservoir continuity. Like all fields discovered before the 1990s in Nigeria's Niger Delta basin, the sedimentary sequence in Etsako Field was analysed to ascertain reservoir continuity using lithostratigraphic correlation technique. The technique groups genetically unrelated reservoirs together into one

lithostratigraphic unit, which often leads to exaggeration of reservoir continuity<sup>2,3,4,5,6,7</sup>. The consequence of lithostratigraphic correlation in the Etsako Field is dry step-out wells ET2, ET4 and ET5 drilled after discovery well ET1 and successful (wet) well ET3. This study aimed at subdividing the penetrated stratigraphic sequence at each well-site within Etsako Field into stratigraphic packages bounded by stratigraphic discontinuities. Depositional conditions within each stratigraphic package were either fairly constant or were progressively changing. The bounding stratigraphic discontinuity surfaces highlight significant changes in depositional conditions, and hence in depositional trends. Thus bounding stratigraphic discontinuity surfaces provide a more natural subdivision of the stratigraphic sequence for interpretive and predictive purposes<sup>8</sup>.

The bounding stratigraphic discontinuity surfaces employed in this study are marine flooding surfaces, and stratigraphic packages they bound are parasequences. According to<sup>9</sup>, parasequence was originally defined in<sup>10</sup> as a relatively conformable succession of beds or bedsets bound by marine flooding surfaces. Thus a parasequence is a genetically related set of beds. They also defined a marine flooding surface to be a surface that separates younger strata from older strata, across which there is an abrupt deepening. The parasequence boundaries (or marine flooding surfaces) form within hundreds to thousands of years, and approximate time markers useful for chronostratigraphy<sup>11, 12, 13, 14</sup>. Successive parasequences with distinctive stacking pattern and bounded by major marine flooding surfaces constitute a parasequence set. Progradational or aggradational parasequence sets below are separated by an unconformity surface from retrogradation parasequence sets above. Retrogradation parasequence sets below are separated by a maximum flooding surface (MFS) from aggradational or progradational parasequence sets above<sup>4, 15</sup>. Interval of the stratigraphic sequence directly underlain by an unconformity surface constitute lowstand systems tract (LST), while the interval overlain by an unconformity surface constitutes highstand systems tract (HST). Transgressive systems tract (TST) is sandwiched between HST above and MFS below, or directly underlain by MFS<sup>4, 16, 17, 18, 5</sup>. The stratigraphic interval bounded above and below by unconformity a surface constitutes a depositional sequence. It is the fundamental unit in sequence stratigraphic analysis, is constituted by parasequences and parasequence sets. Thus sequences, parasequence sets, and parasequences, as well as their component units, form the building blocks of a basin's sedimentary fill.

## **II. Geological Synopsis**

Origin of Niger Delta, as well as other Nigeria's sedimentary basins, is linked with Cretaceous extensional activities within continental plate<sup>19, 1, 20, 21, 22</sup>. Sediment progression in such extensional sedimentary basins is typically skewed seaward, and this makes stratigraphy (rather than structure) the dominant element<sup>23</sup>.

<sup>24</sup> originally divided the Niger Delta's sedimentary sequence into Akata Formation, Agbada Formation, and Benin Formation. Akata Formation is the basal lithostratigraphic unit and its sediments were deposited in marine shelf to bathyal environments. It is overlain by Agbada Formation, which is an alternation of sandstones, siltstones, mudstones and shales. The sediments were deposited mainly in inner neritic environment. Littoral, middle neritic, outer neritic and bathyal sediments are also present. Hydrocarbon reservoirs are predominantly in the Agbada Formation. The Benin Formation is the uppermost unit, and it consists of freshwater bearing massive continental sands, and gravels deposited in an upper deltaic plain environment.

## **III. Software, Data And Methodology Employed**

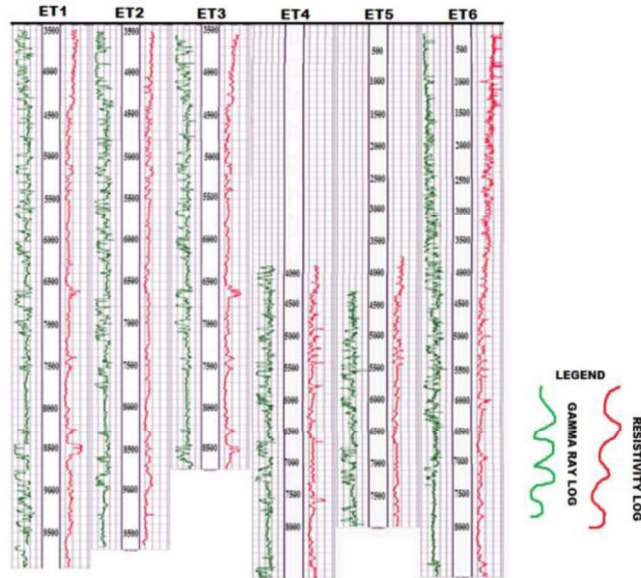
The software employed in this study comprises *Geographix Discovery 5000*, *Microsoft Excel*, *Suffer 11* and *Microsoft Paint*. The open-hole geophysical logs employed are wireline gamma ray and electrical resistivity logs.

The study was created as a project in the *Geographix Discovery* software's data base. The wells' critical information fed into the data base comprises geographic coordinates, measurement datum, well top and bottom depths. Spatial location map of the wells was created using *GeoAtlas* menu of the software. The values of the log content were fed into the data base using the *Prizm* menu. The framework of the gamma ray and resistivity logs was created in the well section menu. Sand percentages were estimated from the gamma ray log data. The base of the Benin Formation (or top of Agbada Formation) was identified and correlated on the basis of the estimated sand percentages, shale thickness and resistivity values. Paraequences were identified within the Agbada Formation on the log framework as intervals bounded by marine flooding surfaces. The parasequences were correlated across the log framework. Similar patterns of parasequences bounded by major marine flooding surfaces were combined into parasequence sets. Maximum flooding surfaces were identified as surfaces that separate retrogradational parasequence set below from progradational parasequence set above. Unconformity surfaces were identified as surfaces that separate progradational parasequence set below from retrogradational parasequence set above. Log intervals directly underlain by unconformity surface were identified as lowstand systems tract. Those that are directly overlain by unconformity surface were identified as highstand systems tract. Hydrocarbon sand reservoirs were identified as intervals that are characterised by low gamma ray value

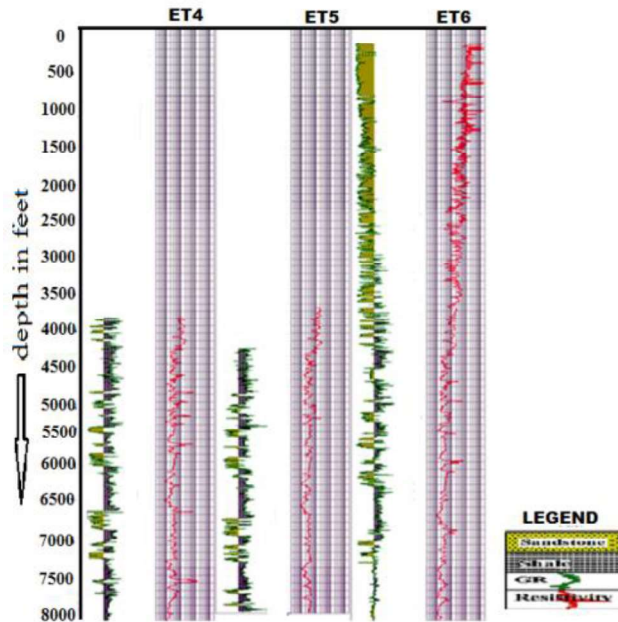
and high resistivity value within Agbada Formation. The hydrocarbon sand reservoirs were related to the systems tracts to identify preferred stratigraphic position for hydrocarbon accumulation in Etsako Field.

#### IV. Results

The framework of the gamma ray and resistivity logs for the wells in the field is figure 2. The lithologic interpretation of the log framework for wells ET1, ET2 and ET3 is presented as figure 3, while figure 4 is the lithologic interpretation of the log framework for wells ET4, ET5 and ET6.



**Figure 2:** Gamma ray and resistivity logs framework of wells in Etsako Field



**Figure 3:** Lithologic interpretation of gamma ray and resistivity log framework for ET1, ET2, ET3

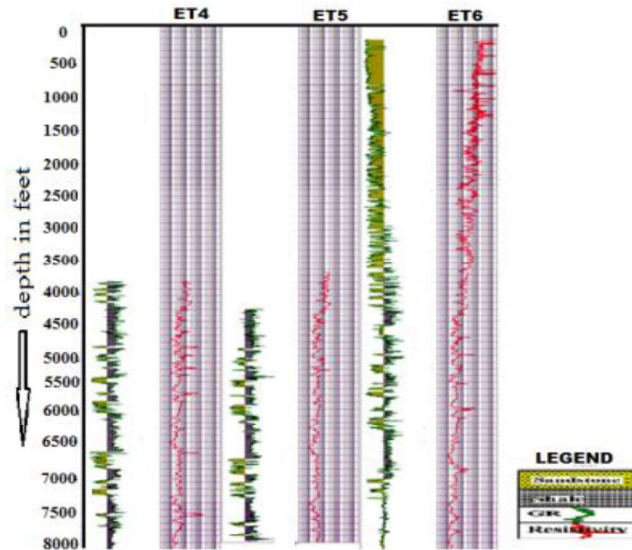


Figure 4: Lithologic interpretation of gamma ray and resistivity log framework for ET4, ET5, ET6

Tables 1 to 6 respectively show sand percentages estimated from lithologic interpretations of the log framework and their inferred depositional environment for ET1, ET2, ET3, ET4, ET5 and ET6.

Table 1: Estimated sand percentages from log framework and inferred lithofacies for ET1

DEPTH INTERVAL(ft)	% SAND	LITHOFACIES	DEPTH INTERVAL(ft)	% SAND	LITHOFACIES
4100-4200	40	paralic	6800-6900	0	marine
4200-4300	40	paralic	6900-7000	20	paralic marine
4300-4400	20	paralic marine	7000-7100	50	paralic
4400-4500	10	marine	7100-7200	30	paralic-marine
4500-4600	5	marine	7200-7300	0	marine
4600-4700	10	marine	7300-7400	0	marine
4700-4800	8	marine	7400-7500	0	marine
4800-4900	0	marine	7500-7600	20	paralic marine
4900-5000	40	paralic	7600-7700	0	marine
5000-5100	0	marine	7700-7800	0	marine
5100-5200	90	continental	7800-7900	0	marine
5200-5300	0	marine	7900-8000	0	marine
5300-5400	10	marine	8000-8100	0	marine
5400-5500	10	marine	8100-8200	0	marine
5500-5600	50	paralic	8200-8300	10	marine
5600-5700	20	marine	8300-8400	0	marine
5700-5800	40	paralic-marine	8400-8500	50	paralic
5800-5900	0	marine	8500-8600	90	continental
5900-6000	10	marine	8600-8700	20	paralic marine
6000-6100	100	continental	8700-8800	20	paralic-marine
6100-6200	50	paralic	8800-8900	90	continental
6200-6300	5	marine	8900-9000	40	paralic marine
6300-6400	0	marine	9100-9200	50	paralic
6400-6500	0	marine	9200-9300	30	paralic marine
6500-6600	0	marine	9300-9400	20	paralicmarine
6600-6700	50	paralic	9400-9500	10	marine
6700-6800	100	continental	9500-9600	0	marine
6800-6900	0	marine	9600-9700	20	marine

**Table 2:** Estimated sand percentages from log framework and inferred lithofacies for ET2

DEPTH INTERVAL(ft)	% SAND	LITHOFACIES	DEPTH INTERVAL(ft)	% SAND	LITHOFACIES
4100-4200	60	paralic	6900-7000	25	paralic marine
4200-4300	100	continental	7000-7100	98	continental
4300-4400	10	marine	7100-7200	98	continental
4400-4500	20	paralic marine	7200-7300	2	marine
4500-4600	10	marine	7300-7400	0	marine
4600-4700	10	marine	7400-7500	0	marine
4700-4800	10	marine	7500-7600	50	marine paralic
4800-4900	50	paralic	7600-7700	40	paralic marine
4900-5000	10	marine	7700-7800	40	paralic marine
5000-5100	40	paralic	7800-7900	0	marine
5100-5200	80	continental	7900-8000	0	marine
5200-5300	50	paralic	8100-8200	0	marine
5300-5400	10	marine	8200-8300	0	marine
5400-5500	40	paralic	8300-8400	10	marine
5500-5600	80	continental	8400-8500	0	marine
5600-5700	70	continental	8500-8600	0	marine
5700-5800	20	paralic marine	8600-8700	50	paralic
5800-5900	20	paralic marine	8700-8800	0	marine
5900-6000	5	marine	8800-8900	98	continental
6000-6100	95	continental	8900-9000	45	paralic marine
6100-6200	50	paralic	9000-9100	0	marine
6200-6300	20	paralic marine	9100-9200	0	marine
6300-6400	0	marine	9200-9300	0	marine
6400-6500	5	marine	9300-9400	100	continental
6500-6600	0	marine	9400-9500	100	continental
6600-6700	0	marine	9500-9600	98	continental
6700-6800	98	continental	9600-9700	0	marine

**Table 3:** Estimated sand percentages from log framework and inferred lithofacies for ET3

DEPTH INTERVAL(ft)	% SAND	LITHOFACIES	DEPTH INTERVAL(ft)	% SAND	LITHOFACIES
4100-4200	60	continental	6400-6500	0	marine
4200-4300	0	marine	6500-6600	0	marine
4300-4400	10	marine	6600-6700	95	continental
4400-4500	0	marine	6700-6800	20	paralic marine
4500-4600	0	marine	6800-6900	0	marine
4600-4700	0	marine	6900-7000	10	marine
4700-4800	10	marine	7000-7100	20	paralic marine
4800-4900	0	marine	7100-7200	5	marine
4900-5000	20	paralic marine	7200-7300	0	marine
5000-5100	0	marine	7300-7400	0	marine
5100-5200	90	continental	7400-7500	5	marine
5200-5300	10	marine	7500-7600	5	marine
5300-5400	0	marine	7600-7700	0	marine
5400-5500	0	marine	7700-7800	0	marine
5500-5600	20	paralic marine	7800-7900	0	marine
5600-5700	50	paralic	7900-8000	0	marine
5700-5800	10	marine	8000-8100	0	marine
5800-5900	10	marine	8100-8200	5	marine
5900-6000	10	marine	8200-8300	0	marine
6100-6200	10	marine	8300-8400	20	paralic marine
6200-6300	5	marine	8400-8500	40	paralic
6300-6400	0	marine	8500-8600	20	paralic marine

**Table 4:** Estimated sand percentages from log framework and inferred lithofacies for ET4

DEPTH INTERVAL(ft)	% SAND	LITHOFACIES	DEPTH INTERVAL(ft)	% SAND	LITHOFACIES
4100-4200	5	marine	6400-6500	0	marine
4200-4300	5	marine	6500-6600	0	marine
4300-4400	0	marine	6600-6700	20	paralic marine
4400-4500	0	marine	6700-6800	100	continental
4500-4600	0	marine	6800-6900	95	continental
4600-4700	5	marine	6900-7000	0	marine
4700-4800	0	marine	7000-7100	20	paralic marine
4800-4900	30	paralic marine	7100-7200	10	marine
4900-5000	5	marine	7200-7300	95	continental
5000-5100	90	continental	7300-7400	0	marine
5100-5200	5	marine	7400-7500	0	marine
5200-5300	0	marine	7500-7600	40	paralic marine
5300-5400	80	continental	7600-7700	0	marine
5400-5500	50	paralic	7700-7800	5	marine
5500-5600	5	marine	7800-7900	0	marine
5600-5700	20	paralic marine	7900-8000	0	marine
5700-5800	0	marine	8000-8100	0	marine
5800-5900	5	marine	8100-8200	0	marine
5900-6000	95	continental	8200-8300	0	marine
6000-6100	40	paralic	8300-8400	0	marine
6100-6200	0	marine	8400-8500	5	marine
6200-6300	0	marine	8500-8600	0	marine
6300-6400	0	marine	8600-8700	10	marine

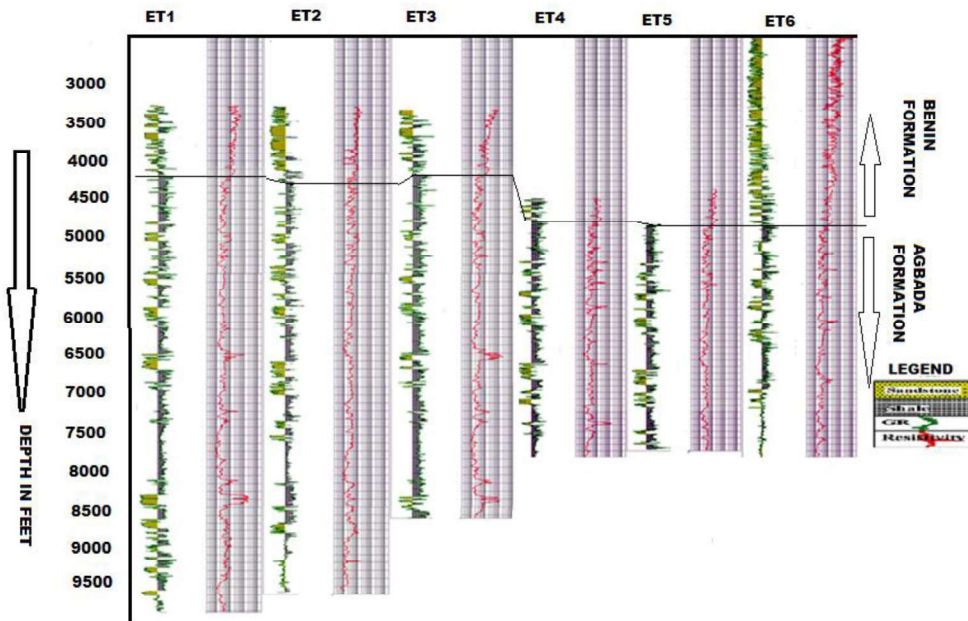
**Table 5:** Estimated sand percentages from log framework and inferred lithofacies for ET5

DEPTH INTERVAL(ft)	% SAND	LITHOFACIES	DEPTH INTERVAL(ft)	% SAND	LITHOFACIES
4100-4200	60	paralic	6100-6200	0	marine
4200-4300	45	paralic	6200-6100	0	marine
4300-4400	0	marine	6300-6400	0	marine
4400-4500	0	marine	6400-6500	0	marine
4500-4600	0	marine	6500-6600	0	marine
4600-4700	0	marine	6600-6700	0	marine
4700-4800	0	marine	6700-6800	40	paralic marine
4800-4900	0	marine	6800-6900	90	continental
4900-5000	10	marine	6900-7000	100	continental
5000-5100	30	paralic marine	7000-7100	0	marine
5100-5200	40	paralic marine	7100-7200	50	paralic marine
5200-5300	10	marine	7200-7300	40	paralic marine
5300-5400	50	paralic marine	7300-7400	5	marine
5400-5500	10	marine	7700-7800	5	marine
5500-5600	90	continental	7400-7500	0	marine
5600-5700	0	marine	7500-7600	0	marine
5700-5800	20	paralic marine	7600-7700	5	marine
5800-5900	10	marine	7700-7800	40	paralic marine
5900-6000	60	continental	7800-7900	0	marine
6000-6100	90	continental	7900-8000	10	marine

**Table 6:** Estimated sand percentages from log framework and inferred lithofacies for ET6

DEPTH INTERVAL(ft)	% SAND	LITHOFACIES	DEPTH INTERVAL(ft)	% SAND	LITHOFACIES
4100-4200	50	paralic	6400-6500	0	marine
4200-4300	20	paralic marine	6500-6600	0	marine
4300-4400	0	marine	6600-6700	0	marine
4400-4500	0	marine	6700-6800	0	marine
4500-4600	10	marine	6800-6900	0	marine
4600-4700	100	continental	6900-7000	10	marine
4700-4800	10	marine	7000-7100	30	paralic marine
4800-4900	0	marine	7100-7200	30	paralic marine
4900-5000	5	marine	7200-7300	0	marine
5100-5200	45	paralic	7300-7400	10	marine
5200-5300	90	continental	7400-7500	50	paralic
5300-5400	0	marine	7500-7600	50	paralic
5400-5500	10	marine	7600-7700	10	marine
5500-5600	90	continental	7700-7800	10	marine
5600-5700	5	marine	7800-7900	20	paralic marine
5700-5800	5	marine	7900-8000	50	paralic
5800-5900	5	marine	8000-8100	50	paralic
5900-6000	5	marine	8100-8200	50	paralic
6000-6100	10	marine	8200-8300	50	paralic
6100-6200	40	paralic	8300-8400	30	paralic marine
6200-6300	80	transitional	8400-8500	40	paralic marine
6300-6400	20	paralic marine	8500-8600	40	paralic marine

The surface that marks the top of first marine interval corresponds to the base of Benin Formation (or top of Agbada Formation). This surface separates the Benin Formation above from Agbada Formation below, as shown in figure 5.



**Figure 5:** Lithostratigraphic surface separating Benin Formation above from Agbada Formation below

The interpreted parasequences within the Agbada Formation are given in figure 6. ET1 has the highest number of parasequences, apparently because it is the deepest well.

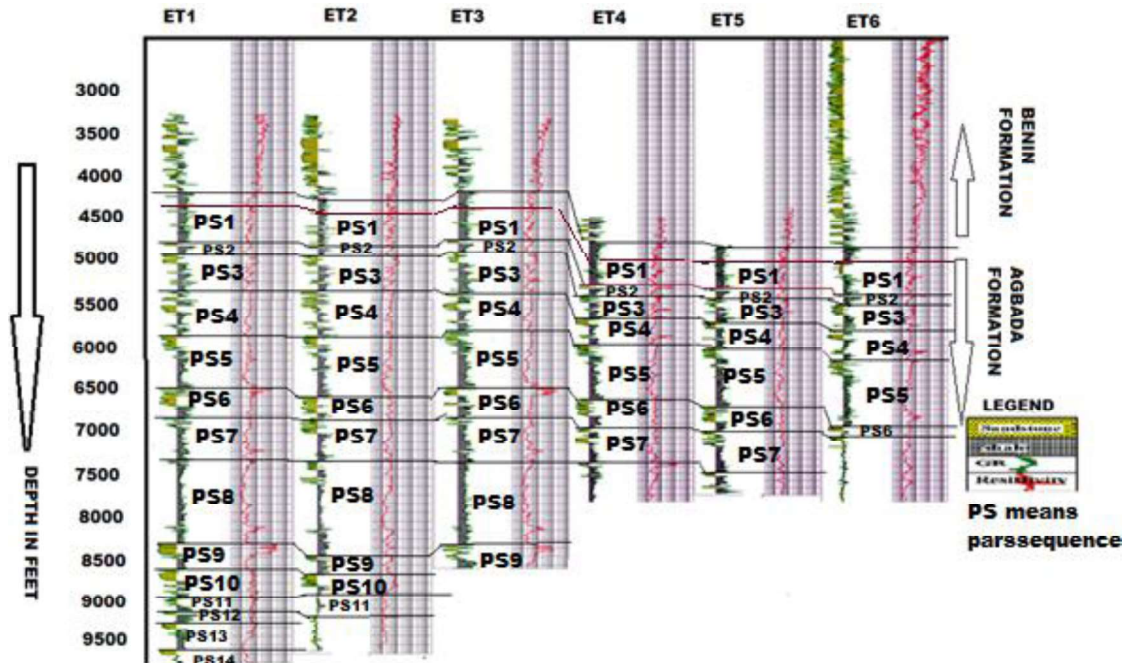


Figure 6: Identified parasequences within Agbada Formation in Etsako Field

The combination of the parasequences into parasequence sets is presented in figure 7. Progradational and retrogradational parasequence sets were identified.

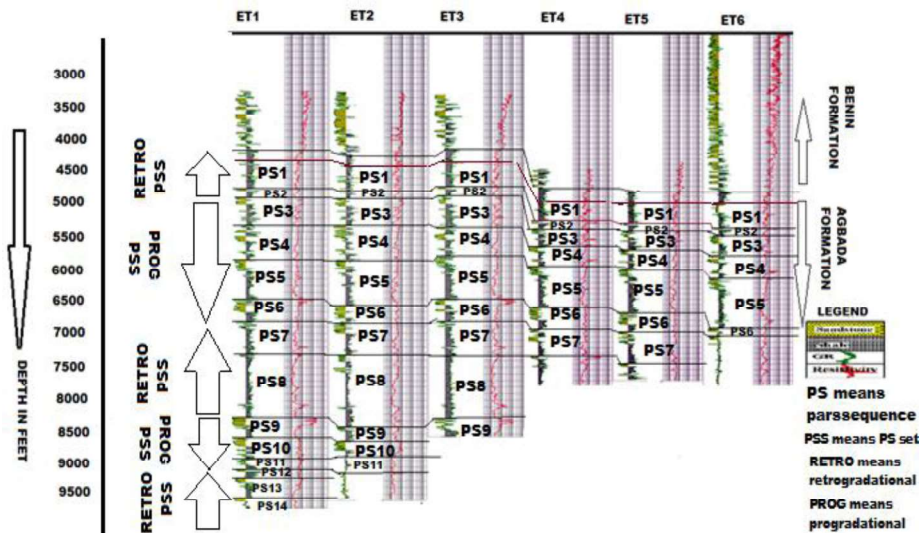


Figure 7: Identified parasequence sets within Agbada Formation in Etsako Field

Figure 8 shows maximum flooding surfaces and unconformity surfaces identified from the vertical juxtaposition of the parasequence sets. Wells ET1 and ET2 contains two maximum flooding surfaces and unconformity surfaces, while the rest wells contain one maximum flooding surface and unconformity surface. This is apparently because ET1 and ET2 are the deepest wells.



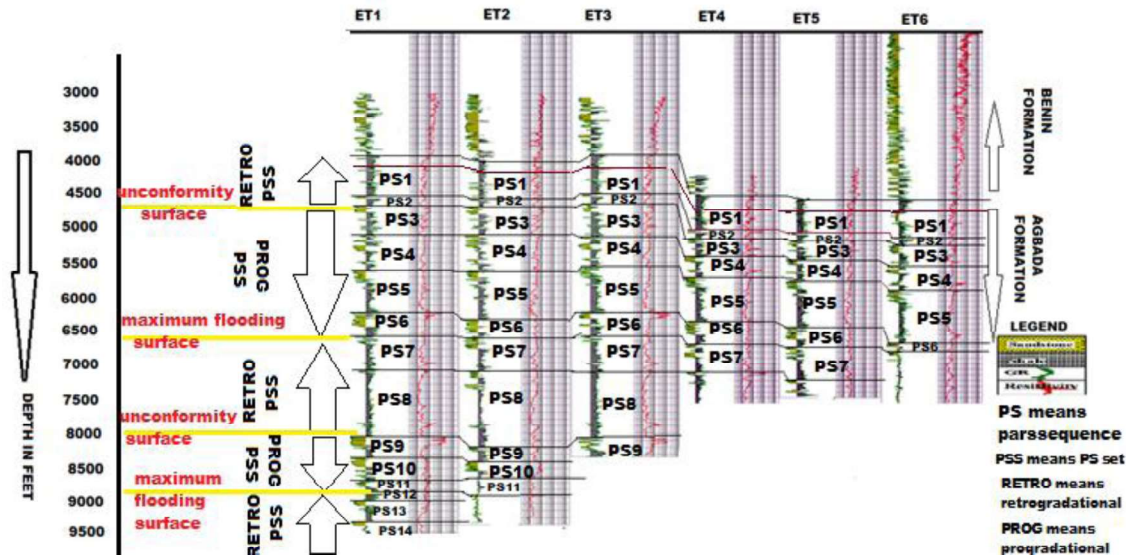


Figure 8: Identified Maximum flooding and Unconformity surfaces within Agbada Formation in Etsako Field

Sands B and F2 in ET6, and sands I and M in ET1 and ET3 are hydrocarbon reservoirs penetrated by the wells. The position of the sands within the parasequence and parasequence set frame work is shown in figure 9.

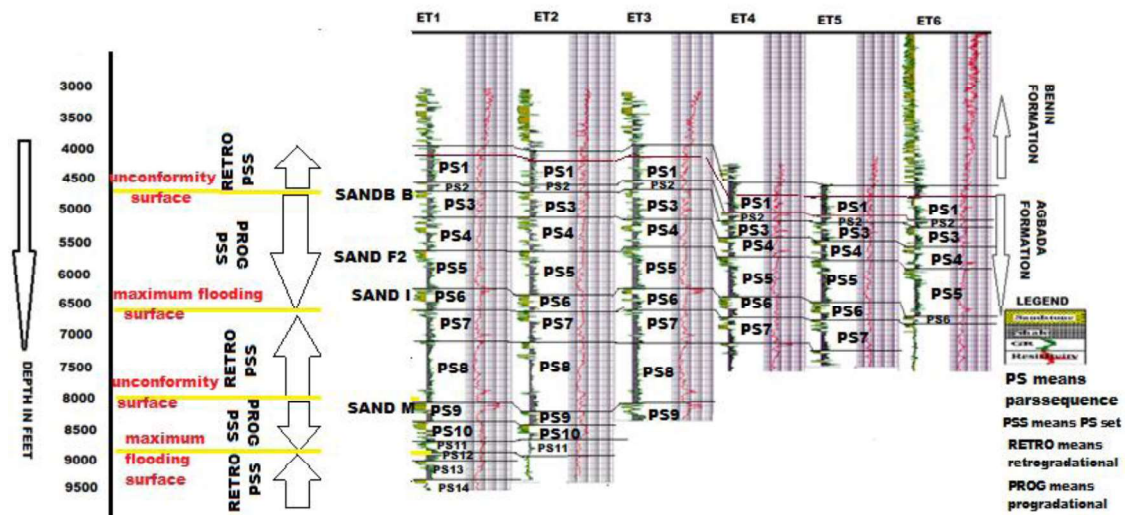
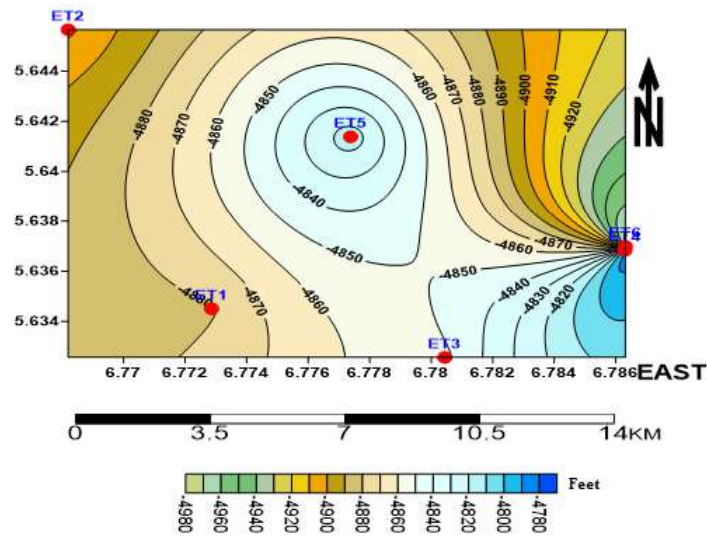


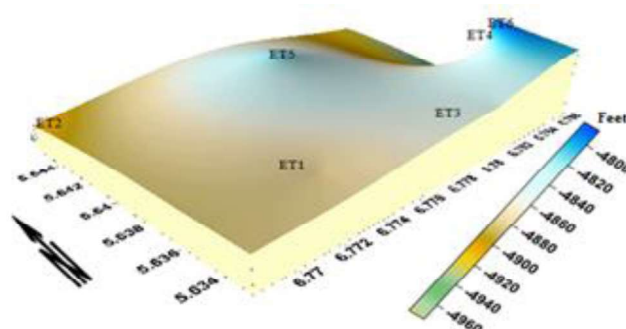
Figure 9: Position of hydrocarbon reservoirs within parasequence and parasequence set framework

Sand B belongs to parasequence PS3. Its cylindrical gamma ray motif suggests channel fill lithofacies underlain by an unconformity surface. Thus sand B is low systems tract. Similarly, sand M (a member of parasequence PS9) is a low systems tract. Sands I ( part of parasequence PS6) and F2(part of parasequence PS5) are directly above a maximum flooding surface. Thus sands I and M constitute highstand systems tract.

The depth structure map of sand B top and its 3D representation are figures 10 and 11 respectively. The sand is hydrocarbon bearing at ET6, where its top is shallowest.

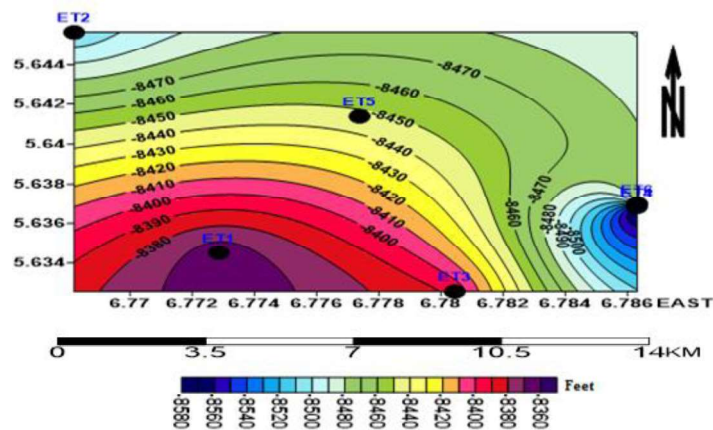


**Figure 10:** Depth structure map for sand B top

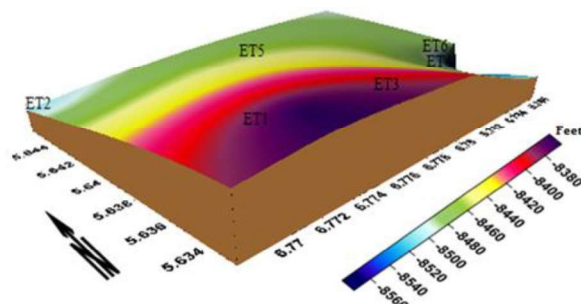


**Figure 11:** 3D representation of depth structure map for sand B top

The depth structure map for sand M top and its three dimensional representation are respectively figures 12 and 13.



**Figure 12:** Depth structure map for sand M top



**Figure 13:** 3D representation of depth structure map for sand M top

The top of the sand is shallower in the field at ET1 and ET3 where it is hydrocarbon bearing.

## V. Discussion

Geophysical well logs constitute a pivotal data for subsurface geologic analysis (Slatt, 2006). Reservoir descriptions and structural geologic models have historically been based on interpretation of well data (Buyl *et al.*, 1988). Approximate time stratigraphic framework results from delineation and correlation of sequence stratigraphic surfaces (Embry, 2009). Structural depth maps (figures 10, 11, 12 and 13) developed from depth to hydrocarbon reservoir sand tops (Sands B and M, obtained within the time stratigraphic framework- figure 9) revealed the following:

1. Infill wells will penetrate hydrocarbon bearing portion of Sand B between longitudes 6.785E to 6.786E and latitude 5.634N to 5.636N. The opportunity exists southwards of ET6 well-site;
2. Infill wells will penetrate hydrocarbon bearing portions of Sand M between longitudes 6.770E to 6.782E and latitude 5.632N to 5.638N.

The time stratigraphic framework (figure 9) revealed that Sands B and M are part of different lowstand systems tract, because they are underlain by unconformity surface. Lowstand systems tracts form major hydrocarbon reservoirs in many areas (Vail, 1987), and a high proportion of produced hydrocarbon in siliciclastic sequences is obtained from them (Wagoner *et al.*, 1996). Hydrocarbon reservoir Sands F2 and I are members of the same highstand systems tract, by virtue of their stratigraphic position above the same maximum flooding surface. Sand I belongs to early part of the highstand while Sand F2 belongs to the late part. Such sands are some of the best coastal sand reservoirs (Vail, 1987). The shale that directly underlie hydrocarbon reservoir Sand F2 in PS5 (figure 9) is an early highstand shale, while that which directly underlie hydrocarbon reservoir Sand I in PS6 belongs to upper transgressive systems tract. It appears both hydrocarbon reservoir sands were charged directly by the shale that directly underlie them. This is because shales of the upper part of transgressive systems tracts and those of early highstand occupy the stratigraphic position of many of the best source rocks in the world, according to Vail (1987).

## VI. Conclusions

Time significant framework was developed from analysis of parasequences and parasequence sets. Only progradational and retrogradational parasequence sets were identified. The vertical stacking patterns of the parasequence sets revealed two unconformity and maximum flooding surfaces. Identified hydrocarbon reservoirs B and M are constituents of lowstand systems tract. Hydrocarbon reservoir sands F2 and I are parts of highstand systems tract. Infill wells will penetrate reservoir portions of sand B within latitudes 5.634°N to 5.636°N and longitudes 6.785°E to 6.786°E. Infill wells will also penetrate hydrocarbon bearing portions of Sand M within latitudes 5.632°N to 5.638°N and longitudes 6.770°E to 6.782°E.

Hydrocarbons accumulate in preferred stratigraphic positions, which are lowstand systems tract and highstand systems tract in Etsako Field. The present wells in the field are shallower than 10000ft. Infill wells should be drilled to about 13000ft to access the lowstand and high

## References

- [1]. Schlumberger. Well evaluation conference, Nigeria Edition. 2009; 292pp.
- [2]. Ager, D.V. The Nature of the Stratigraphic Record, 2<sup>nd</sup> edn, John Wiley and Sons, New York. 1981; 180pp
- [3]. Hubbard, R.J., Pape, J. and Robert, D.G. (1985). Depositional sequence mapping as a technique to establish tectonic and stratigraphic framework and evaluate hydrocarbon potential on a passive continental margin. In: O.R. Berg and D.G. Woolverton (eds). Seismic stratigraphy 11: An integrated approach to hydrocarbon exploration. AAPG Memoir 39, 1985; 79-91.
- [4]. Van Wagoner, J.C., Mitchum, R.M., Campion, K.M. and Rahmanian, V.D. Siliciclastic sequence stratigraphy in well logs, cores and outcrops: concepts for high resolution correlation of time and facies. AAPG Methods in exploration series, no.7. 1990; 55pp.

- [5]. Unuevho, C. Facies analysis of 3D seismic data from eastern Niger Delta, Nigeria. Unpublished PhD thesis, University of Nigeria, Nsukka. 2014; 216pp
- [6]. Unuevho, C. and Onuoha, K.M. Generating new prospects and plays from facies analysis of 3D seismic data: an example from eastern Niger Delta. In: Onuoha, K.M.(ed.). *Advances in petroleum geosciences research in Nigeria*. 2017; 105-325.
- [7]. Tokura, M.M. Open-hole geophysical log sequence analysis and petrophysical estimations in Etsako field, Niger Delta basin of Nigeria. Unpublished MTech thesis, Federal University of Technology, Minna. 2017; 66pp.
- [8]. Walker, R.G. Facies, facies models and modern stratigraphic concepts. In: R.G. Walker and N.P. James (eds). *Facies models*. 1992; 1-14.
- [9]. Embry, A. *Practical sequence stratigraphy*. Canadian Society of Petroleum Geologists. 2009; 79pp
- [10]. Van Wagoner, J.C., Posamentier, H.W., Mitchum, R.M., Vail, P.R., Sarg, J.F., Loutit, T.S., and Hardenbol, J. 1988. An overview of the fundamentals of sequence stratigraphy and key definitions. In: C. Wilgus, B.S. Hastings, C.G. Kendall, H.W. Posamentier, C.A. Ross, and J.C. Van Wagoner (eds.). *Sea level changes: an integrated approach*. SEPM Special Publication 42, 1988; 39-46
- [11]. Sears, J.D., Hunt, C.B. and Hendricks, T.A. Transgressive and regressive Cretaceous deposits in southern San Juan basin, New Mexico: U.S. Geological Survey Professional Paper 193 F. 1941; 101-121
- [12]. Krumbein, W.C. and Sloss, L.L. *Stratigraphy and sedimentation*. San Francisco, W. H. Freeman and co. 1963; 660pp
- [13]. Wilson, J.L. *Carbonate facies in geologic history*. New York, Springer-Verlag. 1975; 471pp.
- [14]. Godwin, P.W. and Anderson, E.J. Punctuated aggradational cycles: a generalized hypothesis of episodic stratigraphic accumulation. *World Journal of Geology*. 1985; 93:515-533.
- [15]. Larue, D.K. and Legarre, H. Flow units, connectivity, and reservoir characterization in a wave dominated deltaic reservoir. *Meren reservoir, Nigeria*. AAPG bull. 2004; 88(3):303-324.
- [16]. Adegoke, O.S. High resolution biostratigraphy, sequence stratigraphy and 3D modeling: Indispensable tools for E&P activities in the New Millennium. *NAPE bull.* 2002; 16 (1): 46-65.
- [17]. Magbagbeola, O. A. and Willis, B.J. Sequence stratigraphy and syndepositional deformation of the Agbada Formation, Robertkiri field, Niger Delta, Nigeria. *AAPG bull.* 2007; 91(7) : 945-958.
- [18]. Shell In-house publication: UIGTDXG. Shell companies in Nigeria Seismic and sequence stratigraphy overview- its applications in subsurface evaluation. *Pub GLP-2011*: 60pp.
- [19]. Whiteman, A.J. *Nigeria: Petroleum geology, resources and potential*. Graham and Trotman, London. 1982; 2: 394pp
- [20]. Onuoha, K.M. Basin subsidence, sediment compaction, and burial history modeling techniques: applicability to the Anambra Basin. *NAPE Proc.* 1986; 2 : 6-17.
- [21]. Onuoha, K.M, and Ofoegbu, C.O. Subsidence and thermal history of the Dahomey Embayment: Implications for petroleum exploitation. *NAPE bull.* 1988; 3(2) :131 – 142. *stand systems tracts below the present well depth,*

Delineation of Time-Stratigraphic Units on Open-Hole Geophysical Logs Acquired In Esaki Field, Onshore Niger Delta of Nigeria" *IOSR Journal of Applied Geology and Geophysics (IOSR-JAGG)* 6.3 (2018): 01-12.