

**IJCSIS Vol. 10 No. 11, November 2012**  
**ISSN 1947-5500**

**International Journal of  
Computer Science  
& Information Security**

**© IJCSIS PUBLICATION 2012**



Cogprints

Google scholar

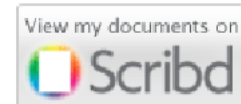

SciRate.com

CiteSeer<sup>x</sup> beta

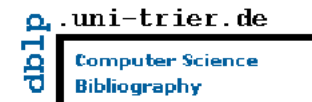

DOAJ DIRECTORY OF OPEN ACCESS JOURNALS



ProQuest

## Editorial Message from Managing Editor

The **International Journal of Computer Science and Information Security (IJCSIS)**, since May 2009, contributes to dissemination of new knowledge in the emerging area of computer applications and practices, and latest advances in cloud computing, information security, green IT etc. The research themes focus mainly on innovative developments, research issues/solutions in computer science and related technologies. IJCSIS editorial board consisting of reputable experts solicits your research contribution to the journal with your research papers, projects, surveying works and industrial experiences. IJCSIS purpose is to enhance the development of theory, research, and practices to support

IJCSIS archives publications, abstracting/indexing, editorial board and other important information are available online on homepage. IJCSIS appreciates all the insights and advice from authors and reviewers. Indexed by the following International Agencies and institutions: Google Scholar, Bielefeld Academic Search Engine (BASE), CiteSeerX, SCIRUS, Cornell's University Library EI, Scopus, DBLP, DOI, ProQuest, EBSCO. Google Scholar reported a large amount of cited papers published in IJCSIS.

IJCSIS is currently accepting manuscripts for upcoming issues based on original qualitative or quantitative research, an innovative conceptual framework, or a substantial literature review that opens new areas of inquiry and investigation in Computer science. Case studies and works of literary analysis are also welcome.

We look forward to further collaboration. If you have further questions please do not hesitate to contact us at [ijcsiseditor@gmail.com](mailto:ijcsiseditor@gmail.com). Our team is committed to provide a quick and supportive service throughout the publication process.

A complete list of journals can be found at:

<http://sites.google.com/sit>

[/ijcsis/](http://ijcsis/)

IJCSIS Vol. 10, No. 11, November 2012 Edition

ISSN 1947-5500 © IJCSIS, USA.

*Journal Indexed by (among others):*



## IJCSIS EDITORIAL BOARD

**Dr. Yong Li**

School of Electronic and Information Engineering, Beijing Jiaotong University,  
P. R. China

**Prof. Hamid Reza Naji**

Department of Computer Engineering, Shahid Beheshti University, Tehran, Iran

**Dr. Sanjay Jasola**

Professor and Dean, School of Information and Communication Technology,  
Gautam Buddha University

**Dr Riktesh Srivastava**

Assistant Professor, Information Systems, Skyline University College, University  
City of Sharjah, Sharjah, PO 1797, UAE

**Dr. Siddhivinayak Kulkarni**

University of Ballarat, Ballarat, Victoria, Australia

**Professor (Dr) Mokhtar Beldjehem**

Sainte-Anne University, Halifax, NS, Canada

**Dr. Alex Pappachen James (Research Fellow)**

Queensland Micro-nanotechnology center, Griffith University, Australia

**Dr. T. C. Manjunath**

HKBK College of Engg., Bangalore, India.

**Prof. Elboukhari Mohamed**

Department of Computer Science,  
University Mohammed First, Oujda, Morocco



# TABLE OF CONTENTS

## **1. Paper 27101203: Design and Implementation of a Secure NeMo (pp. 1-5)**

**Full Text: PDF**

*Diyar Khairi M S, DEEI, FCT, University of Algarve, Portugal  
Amine Berqia, DEEI, FCT, University of Algarve, Portugal*

*Abstract*— Network Mobility (NEMO) Basic Support protocol enables Mobile Networks to attach to different points in the Internet. The protocol is an extension of Mobile IPv6 and allows session continuity for every node in the Mobile Network as the network moves. It also allows every node in the Mobile Network to be reachable while moving around. In this paper detailed implementation of such a system on Linux OS is presented. For wireless security measures, the Wired Equipment Privacy (WEP) method is deployed. Then it is showed that this method can be easily cracked using the BackTrack 5 operating system and the airecrack-ng application. Finally, to solve the security problem, a Wi-Fi Protected Access II (WPA2) Enterprise method is implemented using a Windows Server 2008 R2 with Network Policy Services (NPS) as a radius server and a simple router as a radius client.

*Keywords: NEMO, Security, Radius, Mobile IPv6*

## **2. Paper 29101208: Virtual Zones and Virtual Coordinates on a Multi Layer Infrastructure for Wireless Sensor Networks (VMLI) (pp. 6-15)**

**Full Text: PDF**

*Amina MERBAH, Ahmed KAMIL, Olaf MALASSÉ, Hicham BELHADAoui, Mohamed OUZZIF  
Casablanca, Morocco & Metz, France*

*Abstract*-- Wireless sensor network (WSN) is currently representing a rapidly developing field. The challenge that manifests itself, accordingly, is about reducing the per unit-energy consumption of these networks that show very limited capacity. Several academic undertakings have been interested in maximizing the network's lifetime. The architectures of hierarchical structures ensure the provision of different network nodes in a way that accomplishes this goal. This paper offers a new WSN infrastructure based on a virtual organization through two layers representing the physical layer that contains all nodes of sensor network. The first virtual layer is based on a partitioning into sub-areas that are geographically localized by the sensors. The second is partitioned into four typical layers for the four units (sensors, aggregators, logger and users equipments) of the devices in our platform. This partitioning impacts on (affects) all resources to obtain a global surveillance of WSN at a larger scale. Simulation results have shown that the proposed partitioning algorithm has reduced both the capacity of consumed energy and the number of packets transmitted during topology construction.

*Key-words*— *Wireless sensor networks (WSN), Virtual zones, , Partitioning algorithms, WSN Infrastructures , Energy consumption.*

## **3. Paper 31101216: Brain Connectivity Analysis Methods for Better Understanding of Coupling (pp. 16-22)**

**Full Text: PDF**

*Revati Shriram<sup>1,2</sup>*

<sup>1</sup>*Sathyabama University, Research Scholar, Chennai.*

<sup>2</sup>*Cummins College of Engg for Women, Pune, INDIA*

*Dr. M. Sundhararajan, Shri Lakshmi Ammal Engg. College, Chennai, INDIA*

*Nivedita Daimiwai, Cummins College of Engineering for Women, Pune, INDIA*

*Abstract* — Action, cognition, emotion and perception can be mapped in the brain by using set of techniques. Translating unimodal concepts from one modality to another is an important step towards understanding the neural mechanisms. This paper provides a comprehensive survey of multimodal analysis of brain signals such as fMRI, EEG, MEG, NIRS and motivations, assumptions and pitfalls associated with it. All these non-invasive brain modalities complement and restrain each other and hence improve our understating of functional and neuronal organization. By combining the various modalities together, we can exploit the strengths and flaws of individual brain imaging methods. Integrated anatomical analysis and functional measurements of human brain offer a powerful paradigm for the brain mapping. Here we provide the brief review on non invasive brain modalities, describe the future of co-analysis of these brain signals.

*Keywords-* EEG, fMRI, MEG, NIRS and BMI.

#### **4. Paper 31101217: Applications of fMRI for Brain Mapping (pp. 23-27)**

**Full Text: PDF**

*Nivedita Daimiwal*<sup>1,2</sup>

<sup>1</sup>*Research Scholar, Sathyabama University, Chennai, INDIA*

<sup>2</sup>*Cummins college of Engg. For Women, Pune*

*Dr. M. Sundhararajan, Principal, Shri Laxmi Ammal Engineering College, Chennai, INDIA*

*Revati Shriram, Cummins College of Engg. For Women, Pune, INDIA*

*Abstract* — Brain-mapping techniques have proven to be vital in understanding the molecular, cellular, and functional mechanisms of the brain. Normal anatomical imaging can provide structural information on certain abnormalities in the brain. However there are many neurological disorders for which only structure studies are not sufficient. In such cases it is required to investigate the functional organization of the brain. Further it is necessary to study the brain functions under normal as well as diseased conditions. Brain mapping techniques can help in deriving useful and important information on these issues. Brain functions and brain area responsible for the particular activities like motor, sensory speech and memory process could be investigated. The authors provide an overview of various Brain Mapping techniques and fMRI signal processing methods.

*Keywords-* Functional MRI (fMRI), Signal Processing, Brain Mapping.

#### **5. Paper 31101218: Performance Evaluation of an Orthogonal Frequency Division Multiplexing based Wireless Communication System with implementation of Least Mean Square Equalization technique (pp. 28-32)**

**Full Text: PDF**

*Farhana Enam, Assistant Professor, Dept. of Information & Communication Engineering, University of Rajshahi, Rajshahi, Bangladesh*

*Md. Arif Rabbani, Dept. of Information & Communication Engineering, University of Rajshahi, Rajshahi, Bangladesh*

*Md. Ashraful Islam, Dept. of Information & Communication Engineering, University of Rajshahi, Rajshahi, Bangladesh*

*Sohag Sarkar, Dept. of Information & Communication Engineering, University of Rajshahi, Rajshahi, Bangladesh*

*Abstract*— Orthogonal Frequency Division Multiplexing (OFDM) has recently been applied in wireless communication systems due to its high data rate transmission capability with high bandwidth efficiency and its robustness to multi-path delay. Fading is the one of the major aspect which is considered in the receiver. To cancel the effect of fading, channel estimation and equalization procedure must be done at the receiver before data demodulation. This paper mainly deals with pilot based channel estimation techniques for OFDM communication over frequency selective fading channels. This paper proposes a specific approach to channel equalization for Orthogonal Frequency Division Multiplex (OFDM) systems. Inserting an equalizer realized as an adaptive system before the FFT processing, the influence of variable delay and multi path could be mitigated in order to remove or

reduce considerably the guard interval and to gain some spectral efficiency. The adaptive algorithm is based on adaptive filtering with averaging (AFA) for parameter update. Based on the development of a model of the OFDM system, through extensive computer simulations, we investigate the performance of the channel equalized system. The results show much higher convergence and adaptation rate compared to one of the most frequently used algorithms - Least Mean Squares (LMS).

*Keywords- LMS (Least Mean Square), Adaptive Equalizer, OFDM, Fading Channel, AWGN Channel)*

## **6. Paper 31101224: Microcontroller Based Security System: An electronic application for fire monitoring and surveillance (pp. 33-37)**

**Full Text: PDF**

*Md. Fasiul Alam, MSc. In Electronic System engineering, Politecnico di Milano, Milan, Italy*

*Helena Bulbul, Assistant Professor, United International University, Dhaka, Bangladesh*

*Md. Delwar Hossain, Assistant communication engineer, Boishaki International Television ltd., Dhaka, Bangladesh*

*Abstract* — The importance of electronic security is now an important term in the global world. Due to the lack of modern security equipments we often face problems and lose our valuable assets. Though there are some security system are available in the market but wireless system are not so common and economic to us. Therefore, a Microcontroller Based Security System has been developed to recover that limitation. It can be used for ensuring fire security in Offices, Banks, Apartments, Industry and so on. The system detects the fire fault situation and inform automatically to the desired destination without any human intervention. Microcontroller Based Security System is an intelligent stand alone system with proven performance and stability. The aim of an engineering design is to produce maximum output with minimum cost involved. According to that, our designed system involves low cost yet offers better performance in comparison to other security system available. Microcontroller is the heart in our security system which is interfaced with smoke sensors, SIMCom GSM Module, alarm circuit and LCD display unit. The important feature of the project are it can easily specify the location where the fire occurred and it instructs the SIMCom GSM Module to send SMS to the desired end for taking necessary action immediately. The results obtained stand as a proof of concept for the credibility of implementing wireless based Security System. Achieved result of the project encouraging to us.

*Keywords - Microcontroller, security, sensors, alarm, GPS, GSM*

## **7. Paper 31101227: Internet Fraud as one of the cyber threat and its impact in India (pp. 38-41)**

**Full Text: PDF**

*Ashwini Manish Brahme, Assitant Professor, Indira Institute of Management(MCA), Pune, University of Pune, Maharashtra, India*

*Abstract* - India is becoming superpower in the IT field and also reached to the global world because of Internet but the fraud incidents are on the rise in almost every fast-growing industry across the country. The ratio of Internet fraud is growing significantly in India. Life is about a mix of good and evil so is the Internet. For all the good it does us, cyberspace has its dark sides too. This paper discusses about the Internet Fraud and how the Internet fraud is creating the Cyber Cold War. It also briefs about the Internet Users in India, its Scope and the role of Internet for the Indian Business Growth. This paper talks about the Cyber crime and Cyber threat in India and the motives behind any Cyber attack or Internet Fraud, the tools used for the cyber terrorism, the Impact of Internet Threat at Work, proportion of Internet Fraud in India, and cyber crime cases with different examples. Furthermore paper gives details regarding how the Internet fraud is becoming a growing threat for the online retailers and business, how to deal with Internet Fraud to overcome the cyber threat and the role of Government of India, to avoid the misuse of Internet and the act or penalties for it and the skill to take out the Cyber Threat. This paper also gives the details on the Current status of cyber threat, internet fraud, and future in India with respect to the different security aspects and also talks about the Challenges that India need to face to beat the cyber threat.

*Keywords: Cyber Crime, Cyber Cold war, Internet Fraud, Cyber Threat, IT*

**8. Paper 31101229: Application Of Polynomial Vector (PV) Processing To Improve The Estimation Performance Of Bio Diesel In Variable Compression Ratio Diesel Engine (pp. 42-49)**

**Full Text: PDF**

*Suresh M., Asst. Prof, Mechanical Engineering, Sri Sai Ram Engg. College, Chennai- 44, Tamilnadu, India*

*Maheswar Dutta, Professor and Principal, M.N.R Engg. College, Hyderabad, India*

*Purushothaman S, Professor and Dean, Mechanical Engineering, Udaya School of Engineering, India-629204*

*Abstract* - This paper presents the implementation of polynomial vector back propagation algorithm (PVBPA) for estimating the power, torque, specific fuel consumption and presence of carbon monoxide, hydrocarbons in the emission of a direct injection diesel engine. Experimental readings were obtained using the biodiesel prepared from the waste low quality cooking oil collected from the canteen of Sri Sairam Engineering College, India.. This waste cooking oil was due to the preparation of varieties of food (vegetables fried and non vegetarian). Over more than a week, transesterification was done in chemical lab and the biodiesel was obtained. The biodiesel was mixed in proportions of 10%, 20 % , 30%,40%, 50% with remaining combinations of the diesel supplied by the Indian government. Variable compression ratio (VCR) diesel engine with single cylinder, four stroke diesel type was used. The outputs of the engine as power, torque and specific fuel consumption were obtained from the computational facility attached to the engine. The data collected for different input conditions of the engine was further used to train (PVBPA). The trained PVBPA network was further used to predict the power, torque and brake specific fuel consumption (SFC) for different speed, biodiesel and diesel combinations and full load condition. The estimation performance of the PVBPA network is discussed.

*Keywords: polynomial vector, back propagation algorithm, waste cooking oil, biodiesel.*

**9. Paper 31101234: Computerized Analysis of Breast Thermograms for Early Diagnosis of Breast Cancer (pp. 50-56)**

**Full Text: PDF**

*Mrs. Asmita Wakankar, Sathyabama University, Chennai, India & Cummins College of Engg, Pune*

*Dr. G. R. Suresh, Eswari Engg College, Chennai, India*

*Abstract* — Breast cancer is one of the leading causes of death in women. Early detection of breast cancer is the key to improve survival rate. Malignant tumors causes localized temperature increase on breast surface which shows as hot spot and vascular patterns in breast infrared thermograms. Thermographic detection of breast cancer primarily depends on the visual analysis of these patterns by physicians, which is hard to provide objective and quantitative analysis. This paper proposes computerized analysis of thermograms using a series of statistical features extracted from the thermograms quantifying the bilateral differences between left and right breast area for diagnosis of breast cancer. Thermography is particularly well suited for checking of tumors in their early stages or in dense tissue and implants.

*Keywords- Breast Cancer –Infrared Thermal Imaging-Image Analysis*

**10. Paper 31101235: Information Security on The Communication Network In Nigeria Based On Digital Signature (pp. 57-63)**

**Full Text: PDF**

*O. S. Adebayo (MCPN), V. O. Waziri (PhD) and J.A Ojениyi (MNCS)*

*Cyber Security Science department, Federal University of Technology Minna, Nigeria*

*S. A. Bashir (MNCS), Computer Science department, Federal University of Technology Minna, Nigeria*

*Amit Mishra, Mathematics and Computer Science department, IBB University, Lapai, Nigeria*



*Abstract* - This paper presents simple abstraction concepts for some digital signature scheme algorithms that include ElGamal Signature scheme, Schnorr Signature scheme, Elliptic Curve Signature (ECS), and Digital Signature Standard (DSA). It also examines the security of this digital signature scheme to measure its effectiveness and improve on the variability. The algorithms are essential in securing application in dispatching the documents on the communication network. We try to explain the algorithms in simple form and the examples are experimented in C++ programming language which presupposing little or easy mathematical background comprehension and easy computations.

*Keywords* - *ElGamal Signature scheme, Signature Scheme, Elliptic Curve Signature, Information Security, Digital Signature*

## **11. Paper 31101230: Requirements Elicitation for Software Projects (pp. 64-71)**

**Full Text: PDF**

*Samaher Abdullah AL-Hothali, Department of Computer Science and Engineering, Yanbu University College, Saudi Arabia.*

*Noor Abdulrahman AL-Zubaidi, Department of Computer Science and Engineering, Yanbu University College, Saudi Arabia*

*Anusuyah Subbarao, Department of Computer Science and Engineering, Yanbu University College, Saudi Arabia*

*Abstract* - Requirements elicitation is the practice of collecting the requirements of a system from users, customers and other stakeholders. It is usually realized that requirements are elicited rather than just taking or gathering. This means there are discovery and development of elements to the elicitation process. Requirements elicitation is a complex process connecting with many activities with a different of available techniques, approaches, and tools for performing them. The objectives of this paper is to present the important aspects of how to plan for elicitation, the techniques, approaches, and tools for requirements elicitation, and some elicitation problems.

*Keywords: requirements, elicitation, techniques, approaches, problems.*

# Design and Implementation of a Secure NeMo

Diyar. Khairi M S  
DEEI, FCT  
University of Algarve, Portugal  
dk.19380@gmail.com

Amine Berqia  
DEEI, FCT  
University of Algarve, Portugal  
bamine@ualg.pt

**Abstract**— Network Mobility (NEMO) Basic Support protocol enables Mobile Networks to attach to different points in the Internet. The protocol is an extension of Mobile IPv6 and allows session continuity for every node in the Mobile Network as the network moves. It also allows every node in the Mobile Network to be reachable while moving around. In this paper detailed implementation of such a system on Linux OS is presented. For wireless security measures, the Wired Equipment Privacy (WEP) method is deployed. Then it is showed that this method can be easily cracked using the BackTrack 5 operating system and the aircrack-ng application. Finally, to solve the security problem, a Wi-Fi Protected Access II (WPA2) Enterprise method is implemented using a Windows Server 2008 R2 with Network Policy Services (NPS) as a radius server and a simple router as a radius client.

**Keywords:** NEMO, Security, Radius, Mobile IPv6

## I. INTRODUCTION

This In today's Internet, most communications between end-to-end nodes are using the IP protocol. This protocol assigns a unique address to all nodes connected to the Internet, and provides the mechanisms to transport data between two nodes. IP version 4 (known as IPv4) is the current version of this protocol and was the first widely deployed IP protocol. It was standardized 25 years ago. It is now suffering from several design problems and will certainly restrain the creation of new usages of the Internet. The most debated problem with IPv4 is the lack of addresses, but it is not the only important one. The need for addresses will increase in the near future. With the voice-over-IP becoming more and more popular, we can guess than billions of people will use an IP phone. Each vehicle will embed tens of IP sensors and some multimedia devices. Obviously, all of those equipments need an IP address. The lack of addresses that can be assigned with IPv4 was solved with the Network Address Translation (NAT) system. However, many peer-to-peer applications (such as video-conference or voice-over-IP softwares) suffer from this mechanism: with NAT, the real address of the host is not directly reachable from its correspondent. The communication cannot be directly established and sometimes need a third part. We expect more and more equipments will be connected to the Internet, but the IPv4 protocol is not appropriate anymore to

distribute and manage the IP addresses. The IPv4 scheme to allocate addresses is not based on any hierarchical scheme and the high fragmentation of address space will lead to an heavy load on backbone equipments (the routers). This is one of the most critical problems with the current IP protocol as it might cause the core routers of the Internet to stop working without prior notice.

Eventually, the IPv4 protocol has a monolithic design that makes it difficult to extend, and contains some mechanisms that prevent new protocols like mobile IP to work flawlessly.

As IPv4 cannot meet the demand anymore, the IPv6 protocol (RFC 2460) [3] has been standardized in 1998. It can allocate much more addresses and allows to interconnect undecillions of nodes at the same time. Nodes that connect to the Internet can automatically acquire an address thanks to the auto-configuration mechanism (RFC2462 "IPv6 Stateless Address Autoconfiguration") [2]. IPv6 also simplifies the use of multicast, that allows many to many (including one to many) communications without wasting the bandwidth.

Besides those core features, IPv6 also allows the integration of new features such as improved security, quality of service where IPv4 only provides best effort, and mobility mechanisms with Mobile IPv6 and NEMO Basic Support.

The scalability offered by IPv6 will thus allow to interconnect any equipment and to design new services (such as connecting each car to the Internet) and new usages of the Internet (for instance use the vehicle connectivity for monitoring purposes) that we could not imagine with IPv4.

When a node using an Internet wireless access physically moves, it can be at some point of time out of the coverage area of its access network and needs to move to another one. In addition, because distinct operators may operate or the public target is different (pedestrians, cars etc.), usually no single access technology can cover one big area (such as a city). The node thus has to select the best access technology available.

When a node moves from one access network to another or switches between its access technologies, it acquires a new IPv6 address and is not reachable to its previous one anymore. It implies that all current communications (for example

streaming video from the Internet) are stopped and later restarted by the user or the application.

The Mobile IPv6 protocol (RFC 3775) [4] has been defined to address those issues and allow the node to be always reachable at the same IPv6 address whatever the access network it uses. It allows the host to move transparently for the applications and the users, without the need to reset all the current connections each time the host moves to another access network.

With Mobile IPv6, a host has two addresses while moving in the Internet topology: one permanent address that identifies the host, and the other representing the location in the Internet topology. The Mobile IPv6 protocol takes care of the binding between these two addresses (thanks to a Home Agent), and ensures that the host is always reachable at its permanent address even if it moves in the Internet topology.

On one side Mobile IPv6 manages mobility for only one host, on the other side NEMO Basic Support (RFC 3963) [1] manages mobility for one whole network. Such a network can be for instance a PAN (Personal Area Network, a small network made of IPv6 sensors and PDAs), or an access network deployed in cars, buses or trains. Thanks to NEMO Basic Support, the only computer that needs to have mobility functionalities when the whole network moves is the one that connects the network to the Internet (this computer is called a Mobile Router), whereas with the Mobile IPv6 approach each host in the network would have to handle mobility.

Running Mobile IPv6 on each node can be expensive, especially for little devices such as sensors. NEMO Basic Support only requires changes on the router, all others hosts in the moving network do not need any new feature. Thus all movement in the Internet topology will be handled by the router, transparently to the hosts.

With NEMO, we can imagine lots of scenarios where mobility can play an important role. Using Network Mobility in a train would allow the customers to stay connected to the Internet without disruption during all their trip. Network Mobility in cars can allow to set up a PAN (Personal Area Network) made of tiny IPv6 sensors that can be queried from outside, and PDAs that can have permanent access to the Internet.

## II. THE ARCHITECTURE

In the near future, airplanes, automobiles, trains and even people will carry entire networks of IP devices that connect to the Internet. However, as they move, these networks must change their point of attachment to the Internet due to availability of Internet connectivity. NEMO would enable devices on these networks to maintain unchanged (in the sense of unchanged IP address and

network prefix) connections to other devices on the Internet.

Until recently, wireless devices have been prohibited on commercial airline flights due to the risk of interference with airplanes electrical systems. However, in June of 2005, the Federal Aviation Administration (FAA) gave permission to United Airlines to install Wi-Fi (802.11) wireless network equipment on some of its aircraft [10]. This new regulation will open the door for in-flight Internet service and invite NEMO as a solution to provide uninterrupted Internet connectivity to multiple passengers.

It is not difficult to imagine networked systems or even Internet enabled navigation, multimedia, or driving system on automobiles. NEMO has the potential to provide a single, shared Internet access point to these systems. In the case of critical driving systems, NEMO would be essential in order to maintain continuous connectivity and availability [11].

In July 2004 the European Space Agency (ESA) funded a project called "Broadband to Trains" [5] that used satellite communications as a connection service to provide internet broadband to passengers and train operators.

The system architecture is based on two-way Ku-band satellite transmission to provide connectivity between the internet backbone and a master server on the train. Direct reception of satellite television channels on the same satellite is also possible but has not been trialed in this project.

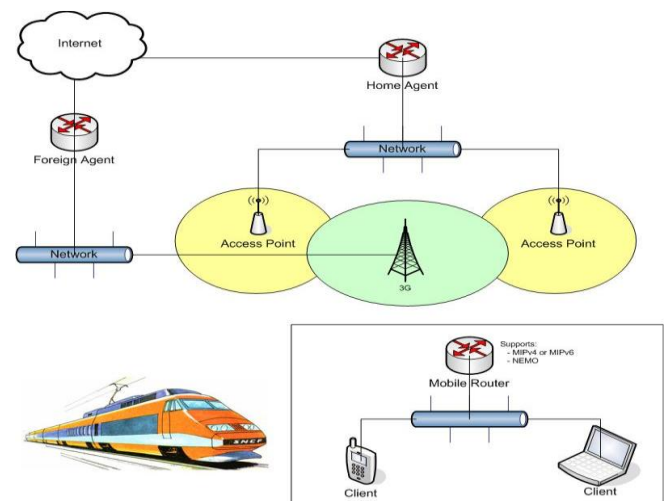

Fig1. System view

A hub earth station provides the connection from the Internet backbone (and from the network operations centre) via the satellite directly to a low-profile tracking antenna on the train. GPRS and Wi-Fi access between the train and available networks is also provided (e.g. in stations and in tunnels). On the train, Wi-Fi (wireless LAN) connections are used between

the master server and customers with Wi-Fi enabled laptops and PDAs.

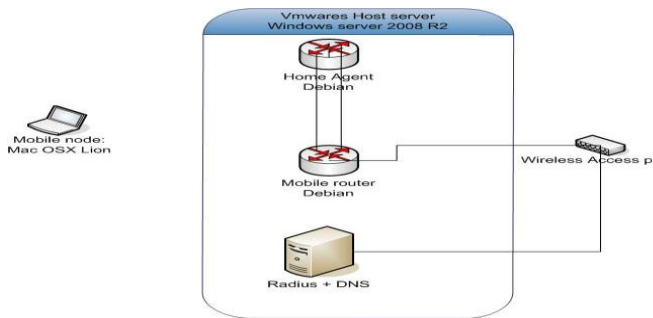

Fig2. System Architecture

### III. EXPERIMENTAL SETUP

For implementation, we used the above architecture. It consists of a quad-core server that runs home agent, mobile router, and radius server. There is also a router and a macbook air. There are two links between HA and MR. The access point connects to MR and radius server [6].



Fig3. System Lab view

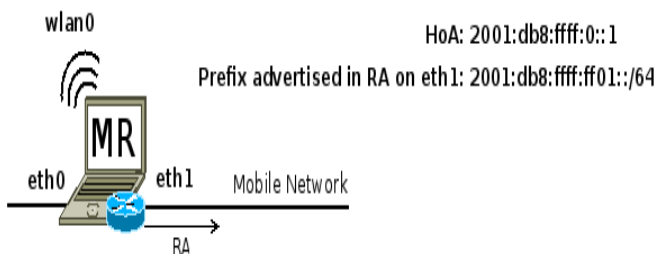

Fig 4. UMIP configuration

Now, we will cover the configuration of the Mobile Router (MR). Here is a modified UMIP Mobile Router configuration. Changes made in the file are marked with NEMO ADDITION.

Modify your /usr/local/etc/mip6d.conf file accordingly.

```
# Sample UMIP configuration file for a Mobile Router
NodeConfig MN;

# Set DebugLevel to 0 if you do not want debug messages
DebugLevel 10;

# Enable the optimistic handovers
OptimisticHandoff enabled;

# Disable RO with other MNs (it is not compatible # with IPsec Tunnel Payload)
DoRouteOptimizationMN disabled;

# The Binding Lifetime (in sec.)
MnMaxHaBindingLife 60;

# Use NEMO Explicit Mode
MobRtrUseExplicitMode enabled; ## NEMO ADDITION ##

# List here the interfaces that you will use # on your mobile node. The available one with # the smallest preference number will be used.
Interface "eth0" {
    MnIfPreference 1;
}
Interface "wlan0" {
    MnIfPreference 2;
}

# Replace eth0 with one of your interface used on # your mobile node
MnHomeLink "eth0" {
    IsMobRtr enabled; ## NEMO ADDITION ##
    HomeAgentAddress 2001:db8:ffff:0::1000;
    HomeAddress 2001:db8:ffff:0::1/64 (2001:db8:ffff:ff01::/64); ## NEMO ADDITION ##
}

# Enable IPsec static keying
UseMnHaIPsec enabled;
KeyMngMobCapability disabled;

# IPsec Security Policies information
IPsecPolicySet {
    HomeAgentAddress 2001:db8:ffff:0::1000;
    HomeAddress 2001:db8:ffff:0::1/64 ;

    IPsecPolicy Mh UseESP 10;
    IPsecPolicy TunnelPayload UseESP 11;
}
```

We enable the NEMO explicit registration mode with the MobRtrUseExplicitMode parameter. Note that this is not mandatory as this is enabled by default. All the other changes take place in the MnHomeLink block. We allow the MR to act as a router by enabling the IsMobRtr parameter. The prefix that we previously configured on the

NEMO HA side has been added to the HomeAddress statement.

No changes are needed in the IPsec configuration. All the traffic from the mobile network will also automatically be protected with IPsec tunnel mode.

The IPsec SAs needed on the MN are the same as the one installed on the HA for that MN. You can then use the same IPsec SAs than the one we described in the HA section, and copy them on the MN in the /usr/local/etc/setkey.conf file.

The MR needs to advertise its MNP in the mobile network using Router Advertisements (RA). For that purpose, we use the radvd software with the below configuration. Copy it in /etc/radvd.conf:

```
# Mobile Router radvd configuration file
# Replace eth1 with your ingress interface name
interface eth1
{
    AdvSendAdvert on;
    MaxRtrAdvInterval 3;
    MinRtrAdvInterval 1;
    AdvIntervalOpt on;
    IgnoreIfMissing on;

    # Mobile Router address on the ingress
    interface
    prefix 2001:db8:ffff:ff01::1/64
    {
        AdvRouterAddr on;
        AdvOnLink on;
        AdvAutonomous on;
        AdvPreferredLifetime 60;
        AdvValidLifetime 120;
    };
};
```

For wireless security measures, we deployed in the beginning the Wired Equipment Privacy (WEP) method. Then it is showed that this method can be easily cracked using the BackTrack 5 operating system [7] and the airecrack-ng [8] application. To solve the security problem, a Wi-Fi Protected Access II (WPA2) Enterprise method is implemented using a Windows Server 2008 R2 with Network Policy Services (NPS) as a radius server and a simple router as a radius client.

Wi-Fi Protected Access (WPA) and Wi-Fi Protected Access II (WPA2) are two security protocols and security certification programs developed by the Wi-Fi Alliance to secure wireless computer networks. The Alliance defined these in response to serious weaknesses researchers had found in the previous system, WEP (Wired Equivalent Privacy).

WPA2 has replaced WPA. WPA2, which requires testing and certification by the Wi-Fi Alliance, implements the mandatory elements of IEEE 802.11i. In particular, it introduces CCMP, a new AES-based encryption mode with strong security. Certification began in September, 2004; from March 13, 2006, WPA2 certification is mandatory for all new devices to bear the

Wi-Fi trademark. To setup the radius server on windows server 2008 r2, we configured:

- Access Points
- Active Directory Domain Services
- DNS
- Network Policy and Access Services
- Active Directory Certificate Services

To test the implementation we used a video streaming from HA to Mobile Node using VLC. During the stream we disconnect one of the links between HA and MR and the stream does not interrupt.

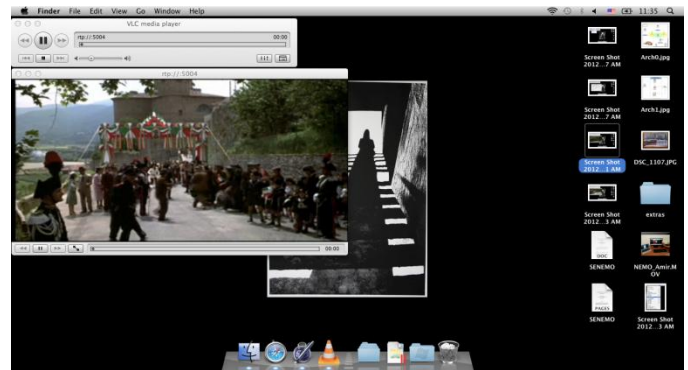

Fig 5. video streaming from HA to Mobile Node using VLC

#### IV.CONCLUSION

In this paper secure network mobility system architecture is proposed and is implemented. Then two different wireless security methods are deployed. It shows that WEP can be cracked easily and WPA2 Enterprise (RADIUS) is more reliable security solution. Finally to show the session persistency of the implementation a video streaming is used. I shows that video playback do not interrupt if one of the links between HA and MR is disconnected during the streaming. For future work we will try to have a tesbed with real velocities.

#### REFERENCES

- [1] [RFC3963] Devarapalli, V., R. Wakikawa, A. Petrescu P. Thubert. "RFC 3963: Network Mobility (NEMO) Basic Support Protocol," IETF, NEMO Working Group, January, 2005.
- [2] Thomson, S. and T. Narten, "IPv6 Stateless Address Autoconfiguration", RFC 2462, December 1998.
- [3] [RFC2460] Deering, S. and R. Hinden, "Internet Protocol, Version 6 (IPv6) Specification", RFC 2460, December 1998.
- [4] [RFC 3775] D. Johnson, C. Perkins, J. Arkko, Mobility Support in IPv6, RFC 3775, June 2004
- [5] ESA project for broadband on trains, [http://www.esa.int/esaTE/SEM1A01YUFF\\_index\\_0.html](http://www.esa.int/esaTE/SEM1A01YUFF_index_0.html)

- [6]<http://www.techrepublic.com/article/ultimate-wireless-security-guide-self-signed-certificates-for-your-radius-server/6148560>
- [7]<http://www.corelan.be/index.php/2009/02/20/cheatsheet-cracking-wep-with-backtrack-4-and-aircrack-ng/>
- [8] C. Devine, Aircrack, <http://www.cr0.net:8040/code/network/aircrack/>
- [9] Leung, K., G. Dommety, V. Narayana, A. Petrescu. "IPv4 Network Mobility (NEMO) Basic Support Protocol," IETF, NEMO Working group, February 24, 2006. <http://ietf.org/internet-drafts/draft-ietf-nemo-v4-base-00.txt>
- [10] "United to offer Web in the air," Reuters, CNNMoney.com, June 6, 2005. [http://money.cnn.com/2005/06/06/technology/personaltech/united\\_wifi/](http://money.cnn.com/2005/06/06/technology/personaltech/united_wifi/)
- [11] Ernst, T., K. Uehara. "Connecting Automobiles to the Internet," Proceedings 3rd International Workshop on ITS Telecommunications (ITST), November 2002. <http://www.sfc.wide.ad.jp/~kei/papers/itst2002-ernst.pdf>

#### AUTHORS PROFILE



**Diyar Khair M S** earned the B.Sc. in Computer Science Department, Al-Mustansiriya University, Baghdad 2002-2003. He was employed at University of Duhok (UoD), Kurdistan Region, Iraq as a program assistant in a computer lab. At the year 2008 he earned his M.Sc. in Data Security from University of Technology (UoT), Iraq – Baghdad and returned back to his own University at Duhok (UoD) as an assistance lecturer at the Computer Department, College of Science, and as the Manager of the Computer center of the University. At the year 2008 he got a EM scholarship to Study PhD in Computer Engineering at University of Algarve under supervision of Professor Amine BERQIA working in NGN-Security.



**Amine BERQIA** earned the B.Sc. and the M.S. in Applied Mathematics from the University Med V, Morocco. He had Ph.D. degrees in Computer Sciences from the University of Dijon, France. He was assistant professor in University of Geneva and coordinator of the Swiss Virtual Campus Project VITELS from 2000 to 2003. Since 2003 till now he is auxiliary professor in University of Algarve, Portugal Since 2007, he has served as the Vice-president of EATIS Europe research group for Europe and America. Since 2008, he has served as the Vice-President of e-NGN research group for Africa and Middle-East which he co-founded. He is member of IEEE and He was awarded by IEEE Education Society in 2012. He has served as chair or co-chair in several international conferences (NGNS'12, EDUCON 2012, NGNS2010, EATIS2007, NOTERE2007...) and has taken part of several international program committees. He published around 50 papers in journals and conferences in the areas of networks performance, remote learning and engineering education.

# Virtual Zones and Virtual Coordinates on a Multi Layer Infrastructure for Wireless Sensor Networks (VMLI)

Amina MERBAH CE/RITM ENSEM Casablanca,Morroco aminamerbah@gmail.com	Ahmed KAMIL CE/RITM ENSEM Casablanca,Morroco ahmedofni@gmail.com	Olaf MALASSÉ A3SI ENSAM/ParisTech Metz,France olaf.malasse@ensam.eu	Hicham BELHADAoui CE/RITM ESTC Casablanca,Morroco belhadaoui_hicham@yahoo.fr	Mohamed OUZZIF CE/RITM ESTC Casablanca,Morroco ouzzif@est-h2c.ac.ma
---	--	---	--	---

**Abstract--** Wireless sensor network (WSN) is currently representing a rapidly developing field. The challenge that manifests itself, accordingly, is about reducing the per unit-energy consumption of these networks that show very limited capacity. Several academic undertakings have been interested in maximizing the network's lifetime. The architectures of hierarchical structures ensure the provision of different network nodes in a way that accomplishes this goal. This paper offers a new WSN infrastructure based on a virtual organization through two layers representing the physical layer that contains all nodes of sensor network. The first virtual layer is based on a partitioning into sub-areas that are geographically localized by the sensors. The second is partitioned into four typical layers for the four units (sensors, aggregators, logger and users equipments) of the devices in our platform. This partitioning impacts on (affects) all resources to obtain a global surveillance of WSN at a larger scale. Simulation results have shown that the proposed partitioning algorithm has reduced both the capacity of consumed energy and the number of packets transmitted during topology construction.

**Key-words—** Wireless sensor networks (WSN), Virtual zones, , Partitioning algorithms, WSN Infrastructures , Energy consumption.

## I. INTRODUCTION:

Progress in the field of wireless networks has largely contributed to the evolution of Internet by facilitating access to users regardless of their geographical location. Like many technological challenges, wireless sensor networks have given way to several applications to emerge such as detecting natural disasters (forest fire, floods ...), and to many intelligent systems as well. Nodes that make wireless sensor networks are small and therefore offer insufficient computational and storage communication, and have very limited energy. Because of its size, a sensor is limited in energy. In most cases, battery replacement is impossible, which means that the lifetime of a sensor depends greatly on the life of the battery.

Consistent applications add the choice of routing protocol data which stands as the primary factor of energy consumption of sensors, and as the factor of data storage for further goals. Current researches have primarily focused on ways to optimize energy consumption by sensor nodes. However, in present traditional architectures, sensors are not fully autonomous because they require the use of cluster-heads, sinks and gateways to communicate with the computer equipment that already exists; adding to this high energy consumption of the cluster nodes. The use of the sinks that connect the network with the base station can produce several weaknesses in most critical monitoring applications since access to WSN is done through the sink node; direct access to sensor nodes without the use of the sink node in critical states is impossible.

The WSN topologies are based on three types of routing protocols (Possess different routing infrastructures) that can eventually be classified into three main categories:

Hierarchical protocols, such as LEACH (Low Energy Adaptive Clustering Hierarchical) is one of the hierarchical routing protocols best known for sensor networks (Ali, M., Ravula, S.K., 2008), (W, Heinzelman., A, Chandrakasan., H, Balakrishnan., 2000). The idea is to form clusters based on areas where there is a strong received signal, and use local cluster-heads as a gateway to reach the destination. PEGASIS (Power-Efficient in Sensor Information Systems) (Akkaya , K., Younis , M., 2005) is an improved version of LEACH protocol. PEGASIS forms chains rather than clusters of sensor nodes so that each node transmits and receives data only from its neighboring node. One node is selected from that chain to carry out transmission to the base station (S, Lindsey., C, Raghavendra., 2002.).

Routing protocols based on geographic location: Minimum Energy Communication Network (MECN) (Rodoplu, V., Ming, T.H., 1999) is a routing protocol that seeks to establish and maintain minimum energy in wireless networks while using low-power GPS. MECN uses a base station as destination of information, which is always the case

for sensor networks. MECN identifies a relay area for each node. The main idea of MECN is to find a sub-network that owns fewer nodes but with less power for transmission between any of the two nodes. This is accomplished by using a localized search for each node while considering its relay area (Akkaya , K., Younis , M., 2005).GAF (Geographic Adaptive Fidelity) (Xu ,Y., Heidemann , J., Estrin, D., 2001) is a routing protocol based on the location of nodes. The location of nodes in GAF could be provided with a GPS or other positioning techniques (Akkaya , K., Younis , M., 2005), Doherty ,L., Pister , K.S.J., El Ghaoui ,L., 2001, (Intanagonwiwat , C., Govindan, R., Estrin, D., 2000)]. The routing protocol GEAR (Geographic and Energy Aware Routing) [(Yu ,Y., Estrin, D., Govindan ,R., 2001), (Singh, S., Raghavendra,C., 1998), (Zeng, K., Ren, K., Lou , W., Moran , P. J., 2009)].It consists of using geographical information. The idea is to restrict the number of data in the directed broadcast by considering only a particular region rather than sending data to the entire network (Akkaya , K., Younis , M., 2005), (Yu ,Y., Estrin, D., Govindan ,R., 2001).

Data-centric protocols, such as SPIN (Sensor Protocols for Information via Negotiation) (Qi ,H., Kuruganti, P. T., Xu,Y., 2002) is the first data-centric protocol that was designed for wireless sensor networks. It has many similarities relative to the directed broadcast. It is effective in reducing redundant data and convenient in saving energy (Akkaya , K., Younis , M., 2005). Diffusion is the process of observing all individual sensors that are deployed in the network where all sensors are treated as destination nodes (Abbas, C. B., González, R., Cardenas, N., Villalba, L. J. G., 2008). The tasks assigned to these sensors are to collect the full view of the environment in the form of data and build a network structure with fault tolerance. Energy consumption during the calculation and communication processes must be controlled in order to extend the lifetime of the sensors within the network.

#### A. Motivation :

Works cited in (Winston, K., Guan, S., Hwee, P.T., 2006) - (Oyman, E.I., Ersoy, C., 2004) present ample research on WSN architectures that adopt several sinks to avoid the problem of localization. In these topologies, data is transmitted to end users by using one of the sinks in network, according to the used routing protocol.

Few research endeavors focus on energy consumption (Amina, M., Hicham, B., Mohamed, O., Olaf, M., 2011) - (Ali, M., Ravula, S.K., 2008), see further data aggregation (Akkaya , K., Younis , M., 2005) - (W, Heinzelman., A, Chandrakasan., H, Balakrishnan., 2000. ). Recently, several studies have focused on the location of multiple sinks in larger scale sensor networks and have optimized the location of the integration points in multi-sink wireless sensor networks (MS-WSN). However, few studies are interested in traffic engineering. Indeed, this major problem of this type of topology is complex due to the difficulty of routing the measured values. Also, we can perceive this complexity in

these works (S, Lindsey., C, Raghavendra., 2002.) - (W, chen., K, Yang., 2008), which provide data routing solutions in similar architectures. These research proposals still suffer from lack of scalability. In addition, the WSN-MP architectures do not allow direct access to sensors. This will be one of our issues to solve.

#### B. Assumptions:

We have proposed a set of assumptions to design VMLI. As is the case in entire wireless sensor networks, a set of gateways are required between the field sensor network and the base station. Contrary to this, we inhibited this process. The set of assumptions that we have proposed to perform such architecture are the following:

- We assume that all network nodes are not mobile.
- All nodes are addressable.
- Each node has a principal identifier
- After deployment of the infrastructure, each node gets three identifiers (a principal identifier, host area identifier, and an identifier responsible in the area).
- Energy transmission and reception of packets is the same for all nodes(that is to say at the *same* level of power)
- The communication channel must support the quality of service and ensure the reliability of data transmitted through the network.

#### C. Contribution :

This article aims to present a novel architecture for wireless sensor networks based on a virtual multilayer structure with low energy consumption. Network devices are grouped by type within specific meta- layers. In general our platform consists of three layers:

- A real layer that presents the physical network.
- A second basic routing layer, which allows us to have the partitioning of the sensor network by area.
- The third organizational layer is designed to have direct access to sensors without passing through a sink, which is the essential element in traditional architectures.
- The final layer consists of a set of layers, each representing a typical type of device (A "Sensor" layer linked to the "Aggregator" layer in turn linked to that of a "Logger" and last to "User" which represents all users in the sensor network).

In addition to direct access, this organization allows us to registr of all values passed by the sensors located throughout the geographic area monitored in distributed data bases. This allows the development of an algorithm that increases our network's reliability. A connection algorithm is proposed to



create a hierarchical organization of the wireless sensor network. To make the architecture most efficient, we have developed algorithms to ensure adequate functioning of the communication process and increase reliability (Amina, M., Hicham, B., Mohamed, O., Olaf, M., 2011).

performance of the architecture. All these algorithms will be integrated in the routing protocol that establishes a compromised quality service and reliability.

## II. PARTITIONING OF INFRASTRUCTURE:

Our approach (VMLI-wsn) carries advantages over existing topologies in terms of energy consumption and reactivity. We have focused on infrastructures which have routing protocols that support the constraint of energy consumption and the hierarchy of the different roles of network nodes. The challenge of this work is to build an infrastructure based on virtual topology without worrying too much about technical conditions. Our goal is to strengthen the ability to access various network devices at any time without having to go through special tools as seen before (sinks) Figure.1. We have also introduced history managers that keep the last values collected by sensors or aggregators on which they are connected. These values are kept for a specific period before they are replaced by new sensed values. This method extends the lifetime of the network and saves all the values marked permanently in history managers in a distributed database, since most application areas require the registration of all the values in the network. Thus, we have proposed in our work (Amina, M., Hicham, B., Mohamed, O., Olaf, M., 2011) algorithms that check reliability and reassure sending all sensor values in the network without losing any message in order to increase the

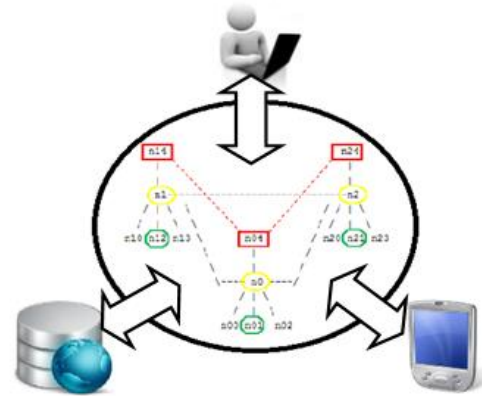

Figure.1: multiple access platform.

### A. Description of the proposed platform:

Our approach is based on the use of an aggregator, but the concept of aggregation in our case is different from the WSN traditional architectures, whose cluster head is an essential element in achieving multiplexing between different clusters. This may exhaust the energy of the cluster head. So our proposal is based on zone partitioning of the network. We have partitioned the network into three layers (Figure.2): a physical layer (c) and two virtual layers (b, a):

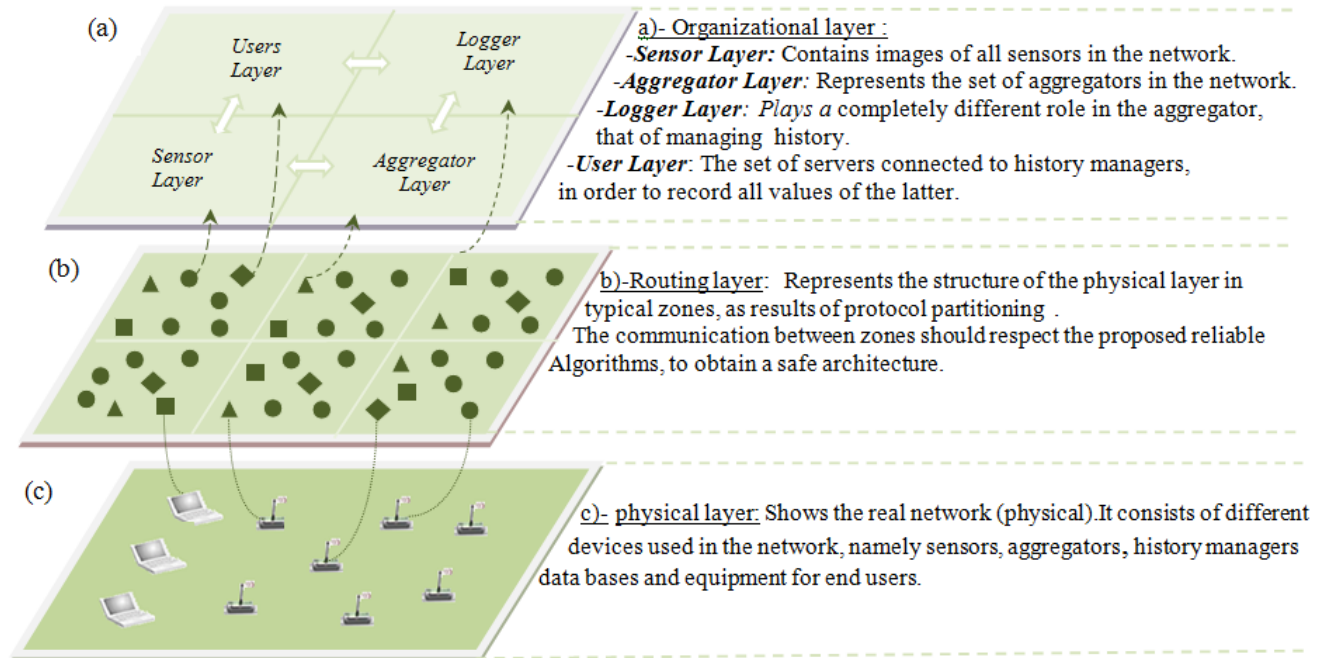

Figure.2: The new proposed architecture for wireless sensors network.

**B. The construction of routing layer & organizational layer:**

From the outset, we assume that the routing layer is partitioned into zones with the same surfaces, and each zone is located geographically in relation to the virtual coordinates of the routing layer (Figure.3). The surface of the zone depends on the nature of the network and on the number of devices deployed in the latter to establish global surveillance. Our proposal does not consider the random deployment of sensor nodes invoked in (W, chen., K, Yang., 2008). Yet, this deployment must follow a process of operation so that it is assigned to the area.

**1) Definition of parameters :**

Routing layer will regroup all the sensors of the geographic layer depending on the type of the devices in different virtual subzones mentioned in (b-Figure.2)

n	IdAg(n,1)	IdAg(n,2)	IdAg(n,3)	IdAg(n,n)
3	IdAg(3,1)	IdAg(3,2)	IdAg(3,3)	IdAg(3,n)
2	IdAg(2,1)	IdAg(2,2)	IdAg(2,3)	IdAg(2,n)
1	IdAg(1,1)	IdAg(1,2)	IdAg(1,3)	IdAg(1,n)
	1	2	3	n

Figure.3- Virtual decomposition of routing layer

To join a new sensor to the grid (Figure.3), this very sensor should be geographically located by sending its physical coordinates in order to be assigned to the closest area. Therefore, we suggest function (1) to calculate the virtual coordinates of the suitable zone.

Let  $C_s(x_s, y_s, z_s)$  the physical coordinates returned by the sensor node such as  $x_s, y_s : \mathbb{R} [0, n [$

Let  $C_z(x_z, y_z, z_z)$  the virtual coordinates of the looking zone. Such as  $x_z, y_z : \mathbb{N} [0, n [$

$U_z$  : Unit of the subzones.

$$C_z([x_s u_z] + 1, [y_s u_z] + 1, [z_s u_z]) \quad (1)$$

In this system, we consider the role assigned for each sensor belonging to the network, which induces an identifier for each role. We consider a maximum of 3 sensors to be connected for each aggregator to avoid both network saturation and aggregator nodes saturation as well (2).

$$\sum \text{Sensors } (1..Sn) = \sum \text{Sensor} + \sum \text{Agg} + \sum \text{Logg} + \sum \text{Db} + \sum \text{User}$$

$$\sum \text{Agg} = \sum \text{Logg} = \sum \text{Sensor} / 3 \quad (2)$$

Such as:

- Sensor: defines the sensor node with the ability to make measurements.
- Agg: defines the ability to aggregate messages coming from the sensors into a single message.
- Logg: Supports the backup of the latest values handled by aggregators.
- Db: The permanent record of values passed by the historic managers.
- User: The user workstations characterizing the application that has the ability to use the sensed values.

**2) Partitioning algorithm of the architecture**

In the proposed algorithm, we take into account both the geographic location of all nodes (each node is equipped with a GPS) and energy capabilities of these which vary from one node to another. Details of the algorithm are listed in Algorithm.1

Firstly, **Case1** (Algorithm.1) allocates an aggregator node which is the essential node for connecting a sensor node, and it assigns an IDZone for each aggregator node (Figure.3), then it ascribes the latter to a historic manager.

**Case2**, treats the case of launching a new sensor in the network. We should first locate it geographically in relation to the nearest zone by a simple referential calculation of its coordinates (1). Then the sensor obtains new virtual coordinates also containing the id of the new zone **Case 2-1**: Then comes the start-up of a sensor.

**Case3**: Thus, we obtain three states, namely:

**Active (x): Case 3-1.** This state means that the sensor has found few asset aggregators, each of which manages less than 3 sensors. Hence, the function "choose" turns the nearest geographical sensor into a new arrival, knowing that the chosen aggregator must be assigned to a logger unit (historic managers).

**Wait (): Case 3-2.** This state means that all zone aggregators are busy (2). The latter will therefore be brought to a halt state for some time to activate a new aggregator and ascribe it to the zone. The sensor will accordingly make a new reconnection.

**Transitory (): Case3-3.** In this state, the sensor cannot be declared in the network. This occurs when the selected aggregator that has just been activated becomes unable to be assigned to a logger unit (an essential operation to the complete functionality of the aggregator).

**Algorithm.1:** Construction algorithm of the new -WSN- infrastructures

Input N.

**Case1:**

```

If (N.id= IdAg) Then
  Browsing[i] [j].ZoneId ==IdAg [z].
  i ++, j ++, z ++
EndIf
    
```

**Case2:**

```

If (N.id= IdSensor) Then
  Check (IdSensor) → v1 = xs And v2 = ys Then
  nxs = v1/ uz, nys = v2/uz
  Return (nxs, nys)
EndIf
    
```

**Case 2-1:**

```

Return IdSensor (nxs, nys, IdZone)
    
```

**Case3:**

**Case3-1:**

```

For Each IdAg.Idzone Do
  If ((S.IdZone) < 3) Then
  An := Choose (min(d( |Cz(fxz(v),fyz(v))|,|Cs(v1 , v2) | ))
  Active (N);
  EndIf
    
```

EndFor

**Case3-2:**

```

ElseIfAll ((S.IdZone) = 3) Then
  Idsensor.SendRequest(Active(newIdAg))
  Idsensor.wait(t)
  SendRequest :
  If (L.ZoneId >0) then
  newIdAg.Affect(NewIdLogger)
    
```

**Case 3-3:**

```

Else Idsensor.transitory ();
  EndIf
    
```

3) Algorithm evaluation( cost of connection):

Connecting a node should follow the steps of the structure cited in the algorithm (Algorithm.1). Furthermore each new connection of an element in the network represents an entity or a sequential transaction to be performed in order to establish its operation. All different interactions of the network are included in the sequence diagram (Figure.4). Nodes (User, Sensor, Aggregator, Logger, and Server) are the fundamental objects of the whole exchanges to carry. This diagram allows us to calculate the cost of simultaneous connections and to invoke a node to join the network.

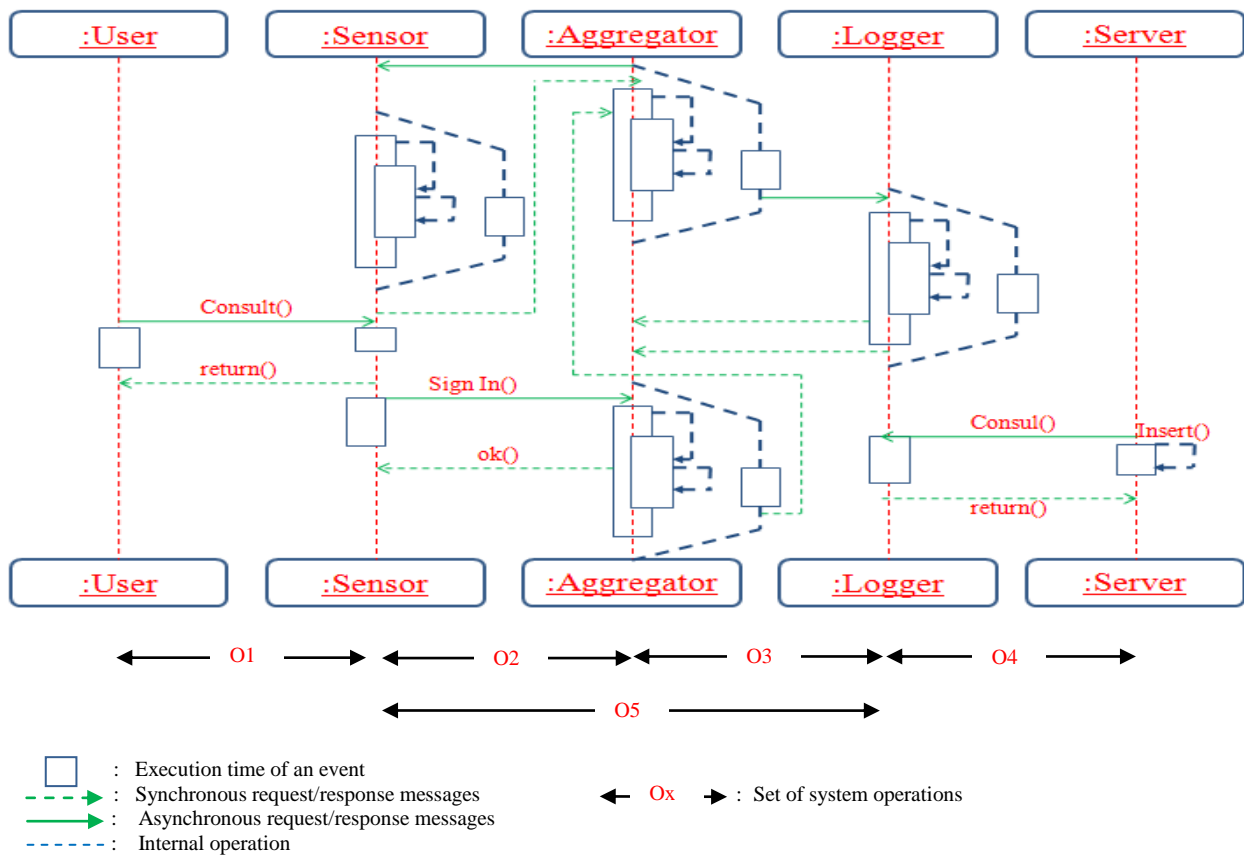

Figure.4: Sequence diagram of the construction process of infrastructure

To estimate the cost of a node connection, we suggest a metric to calculate the cost of each communication between two or several nodes using the two primitives:

*Unicast*: This type can appear to reassure communication between two nodes having the same type. The cost according to this type is  $Cu$ . The different connection requests of this type in a specific zone are: («sensor-sensor», «aggregator-aggregator», and «logger-logger»).

*Multicast*: This type is used to contact all nodes of different types. For our system, the operations of this kind are: (connection of a sensor or an aggregator). The cost is  $Cm$ . Table.1

The scenario becomes that of a subzone composed of "n" aggregator, obviously "3 n" sensor and "n" storage nodes in an area J.

Note that the cost  $Cu$  is higher to that of  $Cm$ .

A: **Total** number of aggregators, L: Total number of storage nodes

Objets	Opération	Cost
User	O1	$Cm + 3Cu$
	O2	$Cm + (2+A) Cu$
Sensor	O3	$Cm + 2Cu$
	O4	$Cm + 3Cu$
	O5	$3Cm + (7+A) Cu$
Aggregator	-	-
	O3	$A Cu$
	O4	$Cm+3Cu$
Logger	O5	$Cm + (3+A) Cu$
	O4	$Cm + (3+L) Cu$
Server	O4	$Cm+2Cu$

Table.1 .The estimated cost for each operation.

### III. SIMULATION AND RESULTS:

In this section, we present the simulation environment and evaluations conducted to test the success of infrastructure algorithm partitioning.

#### A. Simulation environment:

We simulated the behavior of our architecture under the J-Sim simulator. Open-source, J-Sim is built on the basis of ACA (Autonomous Component Architecture), developed entirely in Java. The basic elements of J-Sim are components that communicate interchangeably by sending and receiving data through ports. The specifications of each behavior of a component are determined by contracts. Each component can

be developed and tested independently from all other components of the architecture. This makes J-Sim environment a truly independent, extensible and reusable platform- (Ahmed,S., Chen ,W.P., Jennifer, C.H, Kung, L-C., Li, Ning., Lim, Hyuk., Tyan, H-Y., Zhang, H., 2005).

We examined the performance of our architecture within the parameters of the proposed partitioning zone algorithm. The complete evaluation of the construction phase of virtual layers consists of three metrics: the allocation rate of nodes in each subzone of the virtual layer, the number of sent and received packets to establish the assignment that influences energy consumption during this phase , which is compared with that of zone-based protocol RZRP (W, chen., K, Yang., 2008) In terms of the construction phase, but not the functioning of the RZRP routing., the partitioning process of the compared protocol is similar to that cited in (Joa-Ng , M., Lu, I.T., 1999)

The simulation parameters for the experiments are as follows:

- The dimensions of the monitored area: 1000 m /1000m
- The number of sub areas varies between :20, 30,40, 60, 80 et 100
- Number of nodes: 204, 300, 402, 504 et 600 (Table.2)
- Channel : Wireless
- The topography:
  - 800: #X dimension of the topography.
  - 800: #Y dimension of the topography.
- The communication range of nodes is : 100 meter

Nbr. of nodes	Nbr. of Sensosr	Nbr. of aggregator	Nbr. of Logger
<b>204</b>	136	34	34
<b>300</b>	200	50	50
<b>402</b>	268	67	67
<b>504</b>	336	84	84
<b>600</b>	400	100	100

Table.2: figures for each device

Figure.5 shows an example of topology simulation. The latter is composed of 300 nodes (Table .7). Figure.5. (a) shows the triggering of a new node in the network by sending Cartesian coordinates to join a sub zone. Figure6. (b) shows that the node has found an obstacle that prevents it to be ascribed to the field it must affect. So the node re-launches its reassignment. Figure6. (c) The new arrival is now assigned to a zone, it also obtains an **IDzone** and virtual coordinates ( $X_V$ ,  $Y_V$ ). Figure6. (d) This device starts executing the second part of the partitioning algorithm for its operation.

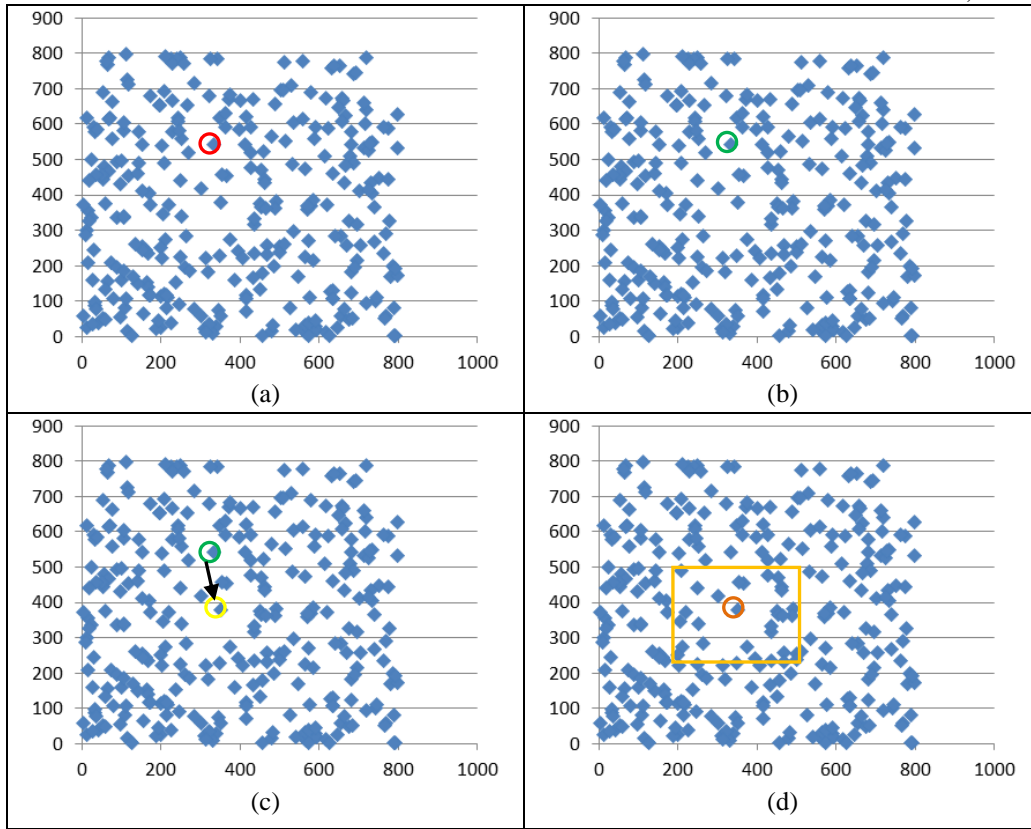

Figure.5: Shooting simulation and positioning of 300 nodes.

**B.Evaluation of nodes allocation rate**

To evaluate the performance of this architecture, the first successful factor is the substantial allocation of all the nodes assigned to ensure better monitoring required of the latter; depending on the parameters of the zone partitioning algorithm. The rate is shown in Figures (6, 7 and 8) by the reverse state (The percentage of unassigned node), based on two criteria: The number of areas on which the routing layer is formed  $Na$ , and a variance number of nodes  $Nn$  (Table.2). We need to find the right relationship between the number of zones and the number of nodes to satisfy the main condition.

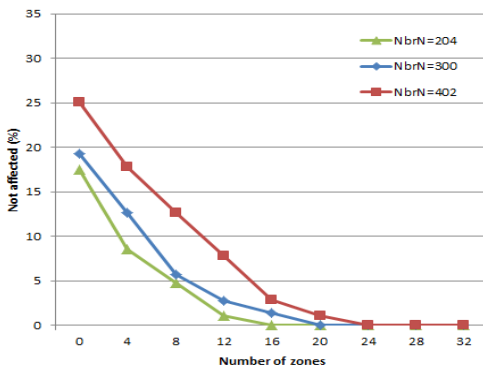

Figure.6: The percentage of unassigned nodes for 204, 300 and 402 nodes

Figure.6 shows that the rate of non-assignment for 300 nodes decreases and becomes null whereas the number of areas increases ( $Na = 16$ ). If we increase the number of nodes to 300 and 402, the rate differs slightly compared to 300 nodes; but also it tends to zero from the ( $Na = 20, 24$ ).

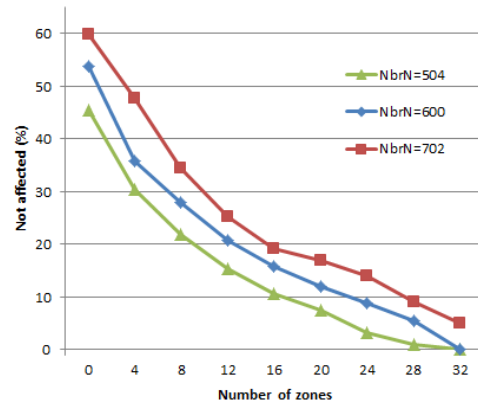

Figure.7: The percentage of unassigned nodes for 504,600 and 702 nodes

If we take a large number of nodes as 504, 600 and 702 with the same variance numbers of zones ( $4 < Na < 32$ ). Figure.7 shows that the rate of non-assignment increases to 60%, then

it begins to decrease, but the establishment of the total allocation only begins from ( $Na = 32$ ), and not for 700 nodes.

Nodes	204	300	402
Average	2,88621951	3,95864634	6,73019512

Table.3: The average assignment for 204, 300 and 402 nodes

Nodes	504	600	702
Average	13,5915556	18,5601111	24,2516914

Table.4: The average assignment for 504, 600 and 702 nodes

Table (3) and (4) show the allocation rate for the 6 types of node numbers tested in a small scale network. We discover a great difference if we increase the number of zones. The rate in table 4 reaches 24.25% of non-success against the rate displayed in table.3 that has not exceeded the threshold of 6.7%.

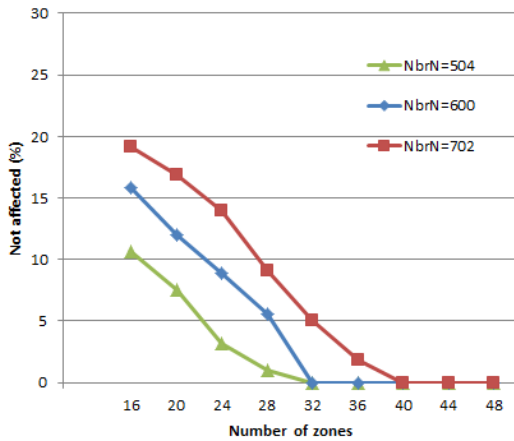

Figure.8: The percentage of unassigned nodes for 504,600 and 702 nodes (more than 16 zones)

Nœuds	504	600	702
Moyennes	1,08057143	2,79153521	5,28948571

Table.5: The average assignment for 504, 600 and 702 nodes (more than 16 zones)

Figure.8 shows that the increasing number of areas with an interesting number of nodes was successful due to reduced rates to 20% for 40 zones and 0% from  $Nn = 40$ , this is reflected in table 5 through the remarkable decline in rates of non-allocation for each iteration node numbers. To sum up, our partitioning algorithm has shown very good results for such large scale networks.

### 1) Average packet delivery ratio :

To strengthen the evaluation of the platform construction, we studied the average ratio of packets transmitted during this phase. The parameters to calculate this ratio are represented in equation (3):

$$A_p = \frac{NP_r}{NP_s} \quad (3)$$

NP<sub>s</sub>: the number of packets sent. NP<sub>r</sub>: The number of packets received.

The graph presented in the figure represents the average ratio calculated for the construction of topology for 200, 300, 400, 500, 600 and 700 nodes:

We find that the average packet delivery ratio reached 0.916657% for the construction of a network of 600 nodes Figure.9.

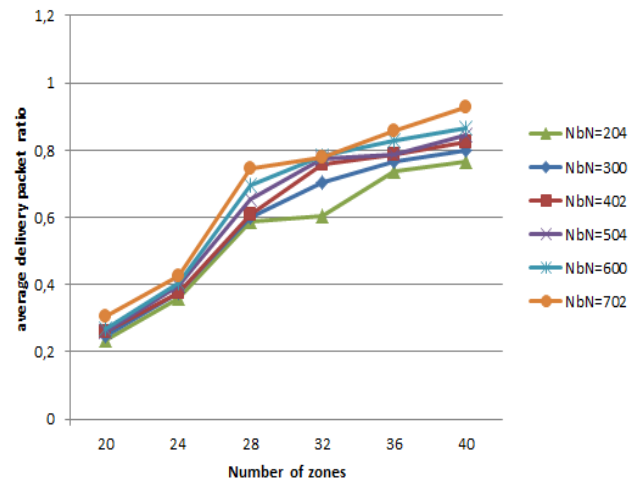

Figure.9: the average packet delivery ratio

### 2) Energy consumption:

Energy consumption in a network in general is influenced by the number of packets transmitted over the network. As we have presented in this work the evaluation of the first part of the construction, energy consumption rate is very reduced Figure.10.

To calculate the energy consumption for each number of nodes, we have used equation (4), quoted in the work (Feeney, L.M.; Nilsson, M., 2001):

$$E_c = m \times size + b \quad (4)$$

Size = the packet size.

m= is the required energy for sending each bit ( $m = 10 \times 10^{-9}$  joules).

b = the required energy to prepare a packet for sending ( $b=100 \times 10^{-9}$  joules).

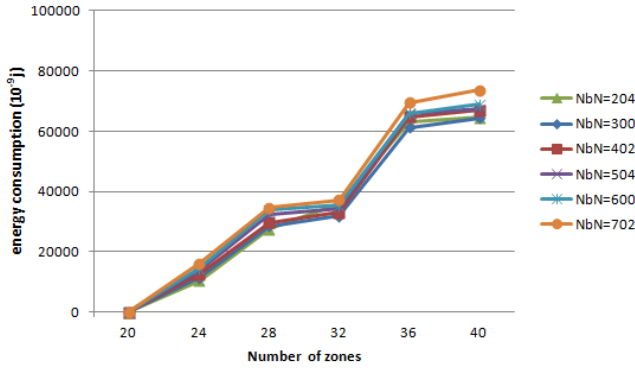

Figure.10: Average of energy consumption

So the average energy consumption is calculated using equation (5):

$$Av(E_c) = E_c \times \left( \frac{\sum(1,n) nE_c}{N} \right) \quad (5)$$

$nE_c$ : The total number of transmitted packets by each node (the number of nodes involved in the network construction).

$Nn$ : Total number of nodes.

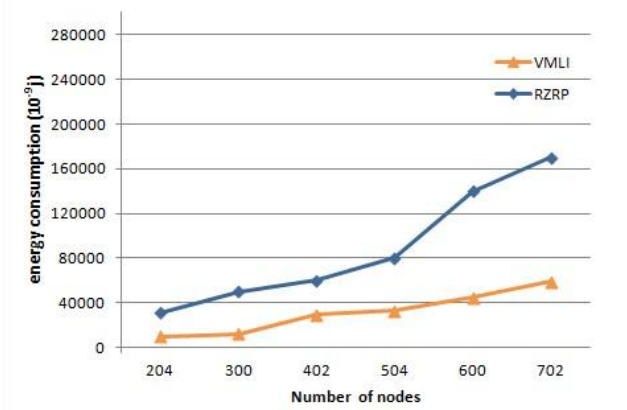

Figure.11: Energy consumption of VMLI vs RZRP

RZRP transmits more packets for the same scenarios of construction with the same number of zones and nodes when compared to VMLI. The results shown in Figure.11 show that the average energy consumption of VMLI is very ideal than RZRP.

### 3) Merits of VMLI:

- Development of a hierarchical architecture based on virtualization of physical network, which allows easy management of the set of devices of the sensor network in a logical manner.
- Assigning different roles to VMLI nodes also avoids energy consumption and network saturation, and provides simplicity of information processing.
- Access to VMLI devices does not pass through gateways, which increases the reliability of the architecture for highly critical sensor network applications.
- This work is the beginning of a future work that will embody the implementation of a specific routing protocol, VMLI, to determine the results on the network in a functional mode.

## IV. CONCLUSION AND FUTURE PERSPECTIVES:

In this paper we have proposed a new management infrastructure for wireless sensor networks based on a virtual organization. The proposed partitioning algorithm has allowed us to partition the WSN into virtual sub-areas, giving us subsequent opportunity to manipulate the infrastructure. Through simulations we have shown the effectiveness of the proposed algorithm in terms of nodes assignment, until the overall allocation of these is established, in order to ensure effective supervision of critical networks at large scale. Thus this new aspect has allowed us to reduce the number of transmitted packets. This results in a decrease of energy consumption of sensors. Also, the organizational virtual layer frees the use of the network through direct access.

For future and current undertakings, we are attempting to achieve the development of a routing protocol based on the proposed infrastructure. The new routing protocol supports the following metrics:

- Management of topology dynamicity of the network, taking into account the mobility of sensor nodes.
- Security of communication and intrusion management.
- Development of reliable algorithms to make a safe infrastructure.
- Implementation of policies for managing the quality of service, which is an essential element to be treated in a WSN.
- Support of fault tolerance.

### ACKNOWLEDGMENT

The authors wish to thank Mr Lhoussain SIMOUR for his proofreading and for his constructive comments, which have successfully completed this work

## REFERENCES

- Winston, K., Guan, S., Hwee, P.T., 2006. "Multipath virtual sink architecture for wireless sensor networks in harsh environments," *InterSense*
- Cheick-Tidjane, K., Francis L., Michael, D., 2010. "Auto-organisation avec canaux et puits multiples de réseaux de capteurs sans fil de grande taille, " Sixième Conférence Internationale Francophone d'Automatique, CIFA 2010, Nancy : France "
- Oyman, E.I., Ersoy, C., 2004. "Multiple sink network design problem in large scale wireless sensor networks," in Proc. of ICC, Paris, France June
- Amina, M., Hicham, B., Mohamed, O., Olaf, M., 2011. "Performance Reliability Assessment of a Mechatronic Sensor System in Wireless Sensor Networks". *International Journal of Computer Science and Network Security*, VOL.11 Nss0.8, August, pp.179-188
- Ali, M., Ravula, S.K., 2008. "Real-time support and energy efficiency in wireless sensor networks". Technical report, IDE0805, January.
- Akkaya, K., Younis, M., 2005. "A Survey on Routing Protocols for Wireless Sensor Networks". *Journal of Ad Hoc Networks*, Vol. 3, No. 3, May, pp. 325-349.
- W, Heinzelman., A, Chandrakasan., H, Balakrishnan., 2000. "Energy-efficient communication protocol for wireless sensor networks ". In the Proceeding of the Hawaii International Conference System Sciences, Hawaii, January.
- S, Lindsey., C, Raghavendra., 2002. "PEGASIS: Power-Efficient Gathering in Sensor Information Systems". *Proceedings of the IEEE Aerospace Conference*, vol. 3, Big Sky, MT, USA, March, pp. 1125-1130.
- W, chen., K, Yang., 2008. "Zone-based Two-level Routing Protocol for Wireless Mobile Ad Hoc Networks: A Fully Reactive Approach". *IWCMC*, August 6-8. 2008
- Rodoplu, V., Ming, T.H., 1999. "Minimum energy mobile wireless networks". *IEEE Journal of Selected Areas in Communications*, Vol. 17, No. 8, , pp. 1333-1344.
- Doherty ,L., Pister , K.S.J., El Ghaoui ,L., 2001. "Convex position estimation in wireless sensor networks". In *Proceedings of the IEEE INFOCOM*, vol.3, Alaska, , pp.1655-1663.
- Intanagonwiwat , C., Govindan, R., Estrin, D., 2000. "Directed diffusion: A scalable and robust communication paradigm for sensor networks". In the *Proceedings of the 6<sup>th</sup> Annual ACM/IEEE International Conference on Mobile Computing and Networking (MobiCom'00)*, Boston, MA, August.
- Yu ,Y., Estrin, D., Govindan ,R., 2001. "Geographical and Energy-Aware Routing: A Recursive Data Dissemination Protocol for Wireless Sensor Networks," *UCLA Computer Science Department Technical Report*, UCLA-CSD TR-01-0023, May 2001.
- Singh, S., Raghavendra,C., 1998. "PAMAS: Power aware multi-access protocol with signaling for ad hoc networks". *ACM Computer Communication Review*, July 1998, pp. 5-26.
- Zeng, K., Ren, K., Lou , W., Moran , P. J., 2009. "Energy aware efficient geographic routing in lossy wireless sensor networks with environmental energy supply". *Kluwer Academic Publishers Hingham, MA, USA.*
- Xu ,Y., Heidemann , J., Estrin, D., 2001. "Geography-informed Energy Conservation for Ad hoc Routing". In *Proceedings of the 7th Annual ACM/IEEE International Conference on Mobile Computing and Networking (MOBICOM'01)*, Rome, Italy, July, pp.70-84.

Qi ,H., Kuruganti, P. T., Xu,Y., 2002. "The Development of Localized Algorithms in Wireless Sensor Networks". Published on *SENSORS* ISSN, 22 July, pp. 1424- 8220.

Abbas, C. B., González, R., Cardenas, N., Villalba, L. J. G., 2008. "A proposal of a wireless sensor network routing protocol". *Springer Science and Business Media .Telecommunication Systems*. March, pp. 61–68.

Ahmed,S., Chen ,W.P., Jennifer, C.H, Kung, L-C., Li, Ning., Lim, Hyuk., Tyan, H-Y., Zhang, H., 2005. *J-Sim: A Simulation and Emulation Environment for Wireless Sensor Networks*, To appear in *Proceedings of the Annual Simulation Symposium (ANSS 2005)*, April.

Feeney, L.M.; Nilsson, M., 2001. Investigating the Energy Consumption of a Wireless Network Interface in an Ad Hoc Networking Environment. In *Proceedings IEEE INFOCOM 2001, Conference on Computer Communications*. Piscataway, NJ, USA, April.; Volume 3, pp. 1548-57.

Joa-Ng , M., Lu, I.T., 1999. "A Peer-to-Peer Zone-Based Two-Level Link State Routing for Mobile Ad Hoc Networks". *IEEE Journal on Selected Areas in Communication*, 17(8):1415-1425.

## AUTHORS PROFILE



**Amina MERBAH** Currently a PhD student ,University Hassan II /ENSEM Casablanca Morroco. Received a master's degree in 2010 at University of Sciences Semlalia-Cadi Ayyad, Marrakech, Morroco.  
Research: Reliability in Wirrelss Sensor Networks.



**Ahmed KAMIL** Currently a PhD student, University Hassan II /ENSEM Casablanca Morroco. Received his engineering degree from *The National School of Mineral Industry*, Rabat. Morroco.



**Olaf MALASSÉ** he is currently attached with National School of Arts/ and Crafts/ ParisTech in Metz/France as Associate Professor in A3SI department.  
Research : Automatic Signal Processing and Computer Engineering.



**Hicham BELHADAUI** Currently working as a Assistant Professor in University Hassan II /ESTC, Casablanca Morroco. Received his Phd degree at National Polytechnic Institute of Lorraine/France.  
Research : Reliability ,Automatic Signal Processing and Computer Engineering.



**Mohamed OUZZIF** Presently working as a Professor Ability in University Hassan II /ESTC. Received his Phd degree from University Hassan II /ENSEM, Casablanca Morroco.



# Brain Connectivity Analysis Methods for Better Understanding of Coupling

Revati Shriram<sup>1,2</sup>

<sup>1</sup>Research Scholar, Sathyabama University, Chennai.

<sup>2</sup>Cummins College of Engg for Women, Pune, INDIA

[revatishriram@yahoo.com](mailto:revatishriram@yahoo.com)

Dr. M. Sundhararajan

Shri Lakshmi Ammal Engg. College, Chennai, INDIA

[msrajan69@gmail.com](mailto:msrajan69@gmail.com)

Nivedita Daimiwal

Cummins College of Engineering for Women, Pune, INDIA

[nivedita.daimiwal@gmail.com](mailto:nivedita.daimiwal@gmail.com)

**Abstract**— Action, cognition, emotion and perception can be mapped in the brain by using set of techniques. Translating unimodal concepts from one modality to another is an important step towards understanding the neural mechanisms. This paper provides a comprehensive survey of multimodal analysis of brain signals such as fMRI, EEG, MEG, NIRS and motivations, assumptions and pitfalls associated with it. All these non-invasive brain modalities complement and restrain each other and hence improve our understating of functional and neuronal organization. By combining the various modalities together, we can exploit the strengths and flaws of individual brain imaging methods. Integrated anatomical analysis and functional measurements of human brain offer a powerful paradigm for the brain mapping. Here we provide the brief review on non invasive brain modalities, describe the future of co-analysis of these brain signals.

**Keywords**- EEG, fMRI, MEG, NIRS and BMI.

## I. INTRODUCTION

The in vivo measurement of blood perfusion in an organ has been a topic of interest for many years. Modern imaging methods provide the opportunity for non-invasive *in vivo* study of human organs and can provide measurements of local neuronal activity of the living human brain (A Toga et al, 2001). These imaging modalities can be divided into two global categories: Functional Imaging or Structural Imaging (Fantini et al, 2001). Functional imaging technique can be used along with the structural imaging to better examine the anatomy and functioning of particular areas of the brain in an individual.

### **Functional Imaging:**

Functional imaging represents a range of measurement techniques in which the aim is to extract quantitative information about physiological function from image-

based data. The emphasis is on the extraction of physiological parameters rather than the visual interpretation of the images. Functional modalities include Single Positron Emission Computed Tomography (SPECT) and Positron Emission Tomography (PET), these are the nuclear medicine imaging modalities. Along with them Functional Magnetic Resonance Imaging (fMRI), Electroencephalogram (EEG), Magnetoencephalogram (MEG), Electrical Impedance Tomography (EIT) can also be named as a functional imaging techniques (Fantini et al, 2001).

### **Structural Imaging:**

Structural imaging represents a range of measurement techniques which can display anatomical information. These modalities include X-ray, Computer Tomography (CT), Magnetic Resonance Imaging (MRI), Transcranial Magnetic Stimulation (TCM) and Ultrasound (US) (Fantini et al, 2001). There are many reasons to determine the regional blood flow in organs such as in the brain or kidney, or in cancerous tissue regions of the body. For example, the assessment of cerebral blood flow and its autoregulation can be used to investigate the normal physiology and the nature of various diseases of the brain (T. S. Koh, Z. Hou, 2002). Also, the efficacy of radiotherapy treatment of cancer cells depends on the local oxygen concentration which is governed by the local blood flow. A convenient, minimally invasive method of assessing blood flow within organs is hence constantly being sought (A Toga et al, 2001).

## II. NEUROIMAGING METHODS

### **EEG: Electroencephalogram**

EEG signal originates mainly in the outer layer of the brain mainly known as the cerebral cortex, a 4–5mm thick highly folded brain region responsible for activities such

as movement initiation, conscious awareness of sensation, language, and higher-order cognitive functions (E.B.J. Coffey et al, 2010). EEG signal describes electrical activity of the brain measured by unpolarized electrodes and belongs to the group of stochastic (random) signals in frequency band of about 0 – 50 Hz with rather high time resolution (units - tens of ms) (T. Heinonen et al, 1999). In contrast, the anatomical localization of specific sources of the electrical activity is very imprecise. Electrical impulses, which come from deep centers of the brain, are not possible to measure directly using the scalp EEG approach (R. Labounek et al, 2012)

### fMRI: Functional Magnetic Resonance Imaging

fMRI is a method of brain activity exploration based on repeated brain volume scanning by a MRI tomography (E.B.J. Coffey et al, 2010, R. Misri et al, 2011). The measured local signal corresponds to changes in the ratio of paramagnetic deoxyHb (HHb) and diamagnetic oxyHb (HbO<sub>2</sub>). It is denoted as a BOLD signal (Blood Oxygenation Level Dependent) (A. Buchweitz et al, 2009). 3D results, which are obtained from fMRI, have an excellent spatial resolution, while its time resolution is significantly worse than for EEG because the period of one brain scan is in the order of seconds. (R. Labounek et al, 2012)

### NIRS: Near Infrared Spectroscopy

Near Infrared (IR) light (wavelength 600 - 1000 nm) easily penetrates the biological tissue (F. Irani et al, 2007, M. Tamura et al, 1997). NIRS is based on the observation that the properties of light passing through a living tissue are influenced by the functional state of the tissue. It is a non-invasive method to measure oxygenation in a localized tissue and measures the transmission of infrared light through biological tissue (G. Strangman et al, 2005). This indicates changes in oxygenation and the concentration of tissue chromophores such as total haemoglobin concentration (tHb) with its constituent oxygenated haemoglobin (HbO<sub>2</sub>) and deoxygenated haemoglobin (HHb) and cytochrome oxidase (CytOx) (Nagyman et al., 2003). NIRS signal obtained is based on capillary-oxygenation-level-dependent (COLD) signal. Figure 1 shows the light propagation path inside the skull and absorption spectra of HHb, HbO<sub>2</sub>, water and CytOx.

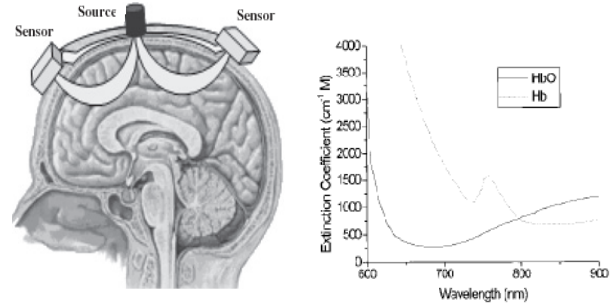

Figure 1: Light Propagation Path inside the Skull [24] & Absorption Spectra of HHb and HbO<sub>2</sub>

NIRS can assess two types of hemodynamic changes associated with the brain activity. Increase in neural activity results in increased glucose and oxygen consumption, which leads to an increase in HbO<sub>2</sub> concentration (H. Matsuyama et al, 2009).

Figure 3 shows HHb and HbO<sub>2</sub> signal acquisition while the subject was doing a cognitive activity. It shows that each time when calculation was done, it caused a cognitive activation in the frontal region as demonstrated by an increase in HbO<sub>2</sub> and a decrease in HHb (S. Perrey et al, 2010).

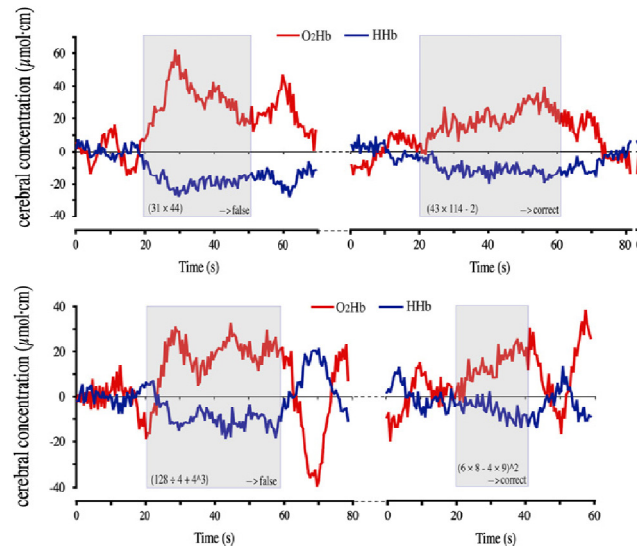

Figure 3: Calculation task was given to the subject, he was asked to resolve the arithmetic operation (as indicated in the gray box) with time pressure and precision demands [25]

### MEG: Magnetoencephalogram

Magnetoencephalography (MEG) is a noninvasive technique for investigating the magnetic field generated by the electrical activity of the neuronal population (E.B.J. Coffey et al, 2010). It records magnetic flux

changes over the surface of the head (~10-15 Tesla) from synaptic discharge tangential currents due to the activity of neurons. MEG measurements are carried out in magnetically shielded rooms, using sensitive superconducting quantum interference devices (SQUIDS) to detect these tiny magnetic fields. The MEG sensor consists of a flux transformer coupled to a SQUID, which considerably amplifies the weak extra cranial magnetic field and converts it into a voltage. It is possible to use MEG to study changes in brain activity even during high frequency deep brain stimulation. MEG data shares the basic features and frequency content of EEG, with predominant activity in delta band, frequency less than 4 Hz (NJ Ray et al., 2007).

### III. FUTURE OF CONCURRENT MEASUREMENT

In non-joint analysis we maximize the likelihood of functions for each modality separately, e.g. when we consider electrophysiological response, hemodynamic response and brain activity separately. In contrast, for a joint analysis we join likelihood function, resulting in single fused unmixing parameter (P. Fox et al, 1994). Figure 4 is the Venn diagram showing the various possibilities for multimodal brain analysis.

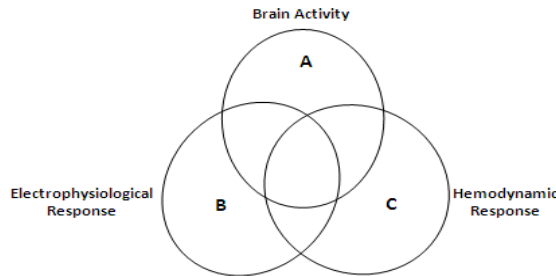

Figure 4: Venn diagram of Multimodal Analysis

Translating unimodal concepts from one modality to another is an important step towards understanding the neural mechanisms underlying these phenomena (Mark E. Pflieger et al). Neuronal decoding w.r.t any behavioral movement or cognitive movement can be correlated by going for a concurrent measurement of EEG, MEG and NIRS (Y. O. Halchenko et al, 2005). EEG, MEG and NIRS based non-invasive BMI development is designed with the objective of restoring the degree of mobility and communication in severely impaired patients who have lost all motor control because of spinal cord injury or who suffer from the locked in syndrome (K. Jerbi et al., 2011). Four multimodal paradigms are discussed below:

#### 1. MEG and EEG

During concurrent measurement of EEG and MEG, the electrical signals measured from the surface of the head

are correlated with the magnetic field generated by the motor cortex during the activity (E.B.J. Coffey et al, 2010).

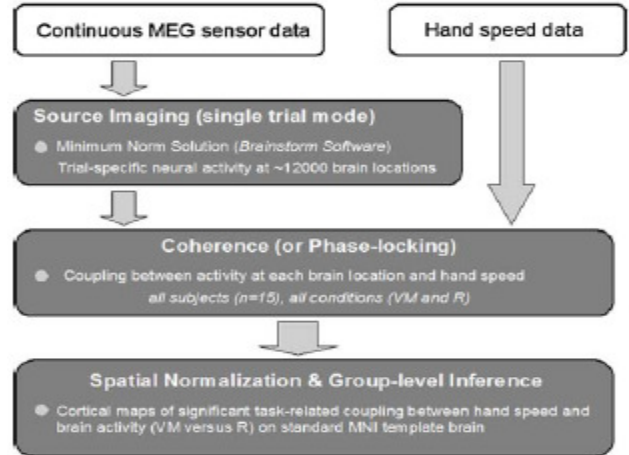

Figure 5: Illustrative Data Analysis Flow of MEG and EEG [8]

The figure 5 shows the illustrative data analysis flow for coherence between hand speed and neuromagnetic brain signals. In this case K. Jerbi et al has performed the data analysis with Brainstorm MEG and EEG toolbox.

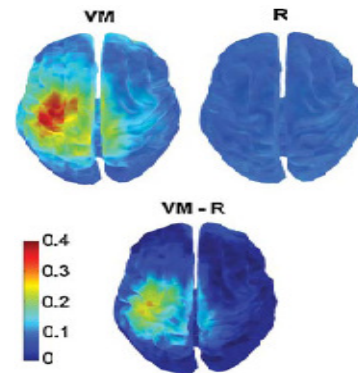

Figure 6: Coherence Maps between MEG and EEG [8]

Figure 6 shows the Z- Transformed coherence maps depicting low frequency coupling between cortical activity and time varying hand speed. The maps are shown for 'Visuomotor' – VM, the 'Rest Condition' – R and difference between the two (VM-R). The peak of the coherence between the brain and the hand speed was located in the contra-lateral primary motor cortex (K. Jerbi et al., 2011)

**Application:** This concurrent modality research offers the insight into non invasive brain computer interface (BCI) approach for the practical implementation. It is also used to measure additional information about epileptic activity, not seen when only EEG is measured.

## 2. EEG and fMRI

Electroencephalography and Functional Magnetic Resonance are two different methods for measuring neuronal activity in the brain. EEG provides excellent temporal resolution while fMRI preferred for its high spatial resolution (D. Mantini et al, 2010.) Concurrent analysis of EEG and fMRI is used to identify blood oxygen dependent (BOLD) changes associated with pshiological and pathological EEG events (H. Laufs et al, 2003). Figure 7 shows the block diagram of concurrent analysis of EEG and fMRI. EEG was acquired simultaneously with fMRI by using 30 MR compatible electrodes with a sampling frequency of 5KHz. The main interest of this study is to create software which would combine EEG and fMRI to facilitate work of neurologist and researchers (E. Martínez-Montes et al, 2004).

Relationship between EEG and fMRI is not precisely known, though few publications comment on negative correlation between alpha band of EEG and BOLD signal. (R. Labounek et al, 2012). The finding suggests that power changes in EEG rhythms are associated with activity changes in the brain circuits (H. Laufs et al, 2003).

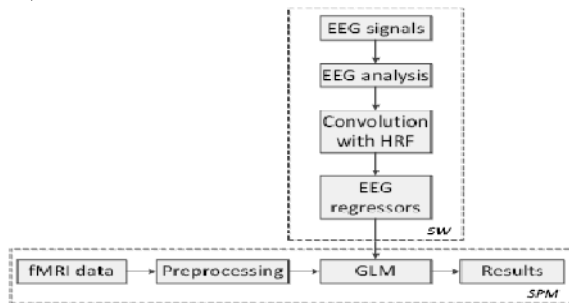

Figure 7: Block Diagram of Concurrent Analysis of EEG and fMRI [23]

**Application:** EEG-fMRI has potential to localize the neuronal activity with both high spatial and temporal resolution. This concurrent modality research offers the new possibilities in the investigations of brain rhythms, sleep patterns, and epilepsy. In the field of epilepsy, simultaneous EEG-fMRI is necessary for the study of the hemodynamic correlates of pathological discharges due to their subclinical nature. These studies have demonstrated BOLD increases and decreases in relation to sharp waves and sharp- and slow-wave complexes (K. Blinowska et al, 2009).

## 3. NIRS and EEG

EEG-NIRS measurement depends on various physical properties such as conductivity, absorption and scattering coefficients of the head tissues such as scalp, skull, gray matter, white matter and cerebral blood flow (CBF).

NIRS requires the light in near infrared (NIR) region to determine cerebral oxygenation, blood flow and metabolic status of the brain. It provides non-invasive means of monitoring the brain function and biological tissue because of relatively low absorption by water and high absorption by HHb and HbO<sub>2</sub> in the range of 600-1000 nm wavelength (Herve' F et al, 2008).

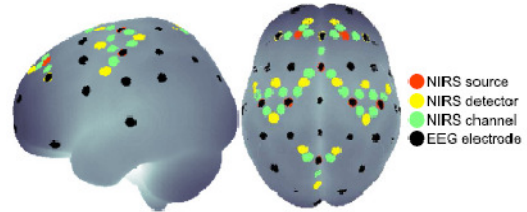

Figure 8: Locations of EEG Electrodes and Source and Detectors of NIRS System [26]

Figure 8 shows the placement of EEG electrodes along with the NIRS source and detectors for the EEG-NIRS concurrent analysis (S. Fazli et al, 2012).

**Application:** This concurrent modality has been used to investigate the synchronized activities of neurons and the subsequent hemodynamic response in human subjects. This simple and comparatively low-cost setup allows to measure hemodynamic activity in many situations when fMRI measurements are not feasible, e.g. for long-term monitoring at the bedside or even outside the lab via wireless transmission.

## 4. fMRI and NIRS

NIRS signals correlate highly with BOLD fMRI. The strong correlation between the two means that many fMRI findings of regional activity specificity in the cerebral cortex can be used to guide NIRS research applications, and to better understand experimental results (E.B.J. Coffey et al, 2010).

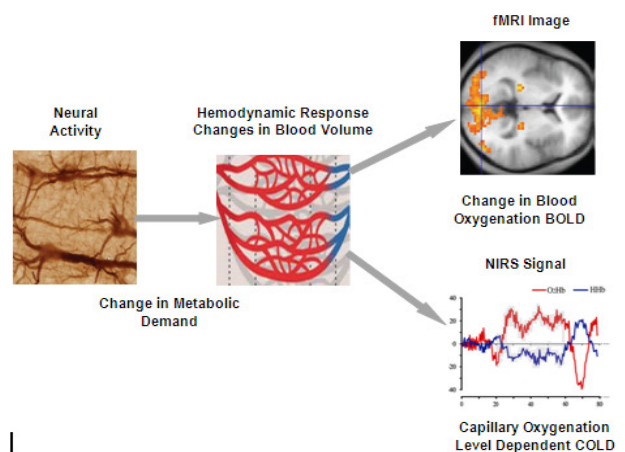

Figure 9: Neuronal Correlates of BOLD & COLD Signal [27]

Figure 9 shows the chain of events and factors that link neural activities to BOLD signal in fMRI image and COLD in NIRS signal. Neural activity through neurovascular coupling influences the metabolic demand. Metabolic changes impact on hemodynamic response which is dependent on physiological factors such as local cerebral blood flow, HHb/HbO<sub>2</sub> ratio, blood volume, and vascular geometry (K. Blinowska et al, 2009). When a brain area is activated, metabolic activity increases, leading to a brief decrease in HbO<sub>2</sub> and increase in HHb about 2 s in the immediate vicinity of the activated neurons. This stimulates the increase of blood flow to a wider area, which causes HbO<sub>2</sub> levels to begin to increase to a peak at about 5s following neural firing, and then slowly declining over about 5–10 s after neural activity returns to normal (E.B.J. Coffey et al, 2010).

**Application:** This concurrent modality research offers the better understanding of brain activation w.r.t. cognitive and behavioral changes.

#### IV. COMPARISON OF VARIOUS MODALITIES

Various brain modalities are compared in table 1, based on spatial resolution, temporal resolution. Advantages, disadvantages and applications of each modality are listed in the same table.

Table 1: Overview of Neuroimaging Modalities

Imaging Method	Resolution	Application	Advantages	Disadvantages
<i>Functional Imaging Methods</i>				
EEG	S - Low T - High	Study various rhythms, epilepsy, preoperative mapping, degenerative disorders	Non-invasive, no ionizing radiation, widely used, low cost	Low spatial resolution
MEG	S - Medium T - High	Study epilepsy	Non-invasive, no ionizing radiation, can identify epileptic foci	Low spatial resolution
fMRI	S - High T - Low	Preoperative mapping, functional mapping	Non-invasive, can perform functional imaging	High cost
NIRS	S - Low T - High	Functional mapping	Non-invasive, low cost, no ionizing radiation	Low spatial resolution

S - Spatial Resolution; T - Temporal Resolution

#### V. CONCLUSION

MEG and EEG provide an excellent temporal resolution of neuronal dynamics; while fMRI provide an alternative measure of neural activation based on hemodynamic changes in the brain with a very good spatial resolution. Near-infrared spectroscopy (NIRS) is a non-invasive method that enables real-time monitoring of tissue oxygenation of the brain because of this it is receiving

increasing interest as a functional neuroscientific technique, complementing neuroelectric approaches such as EEG. NIRS can be applied in a variety of conditions as bedside monitoring in intensive care and in the operating theatre, where fMRI can be difficult to apply. All these non-invasive brain modalities complement and restrain each other and hence improve our understating of functional and neuronal organization. Spatially, temporally, physiologically, behaviourly and cognitively accurate computational models of the neuronal systems are the ultimate goals of the functional brain imaging. This goal can be achieved by integrating the diversity of various brain mapping techniques. By combining the various modalities together, we can exploit the strengths and flaws of individual brain imaging methods.

#### ACKNOWLEDGMENT

The authors are grateful to Dr. Madhuri Khambete for her help towards the completion of this paper, as well as for providing valuable advice.

I would also like to thank my colleagues from Instrumentation and Control Dept. of Cummins College of Engineering for Women for their feedback during the discussions.

#### REFERENCES

- [1] Gary Strangman, David A. Boas, and Jeffrey P. Sutton, "Non-Invasive Neuroimaging Using Near-Infrared Light", Society of Biological Psychiatry, Vol 52:679–693, 2005.
- [2] A.W. Toga, P.M. Thompson, "The Role of Image Registration in Brain Mapping", Image and Vision Computing 19 (2001) 3–24.
- [3] D. Salas-Gonzalez, J.M. Górriza, J. Ramírez, I. Álvarez, M. López, F. Segovia, C.G. Puntonet, "Two Approaches to Selecting Set of Voxels for the Diagnosis of Alzheimer disease using Brain SPECT Images", Digital Signal Processing 21 (2011) 746–755.
- [4] T.S. Koh, Z. Hou, "A Numerical Method for Estimating Blood Flow by Dynaic Functional Imaging", Medical Engineering & Physics 24 (2002) 151–158.
- [5] Ripen Misri, Dominik Meier, Andrew C. Yung, Piotr Kozlowski, Urs O. Häfeli, "Development and Evaluation of a Dual-Modality (MRI/SPECT) Molecular Imaging Bioprobe", Nanomedicine: Nanotechnology, Biology, and Medicine xx (2011) xxx–xxx (Article is in Press).

- [6] Augusto Buchweitz, Robert A. Mason, Lêda M. B. Tomitch and Marcel Adam Just, "Brain Activation for Reading and Listening Comprehension: An fMRI Study of Modality Effects and Individual Differences in Language Comprehension", *Psychology & Neuroscience*, 2009, 2, 2, 111 – 123.
- [7] Peter T Fox, Marty G Woldorff, "Integrating Human Brain Maps", *Current Opinion in Neurobiology* 1994, 4:151-156.
- [8] K. Jerbi, J.R. Vidal, J. Mattout, E. Maby, F. Lecaigard, T. Ossandon, C.M. Hamamé, S.S. Dalal, R. Bouet, J.-P. Lachaux, R.M. Leahy, S. Baillet, L. Garnero, C. Delpuech, O. Bertrand, "Inferring hand movement kinematics from MEG, EEG and intracranial EEG: From brain-machine interfaces to motor rehabilitation", *IRBM* 32 (2011) 8–18.
- [9] H. Laufs, A. Kleinschmidt, A. Beyerle, E. Eger, A. Salek-Haddadi, C. Preibisch, K. Krakow, "EEG-correlated fMRI of Human Alpha Activity", *H. Laufs et al. / NeuroImage* 19 (2003) 1463–1476
- [10] Sarah J. Erickson, Anuradha Godavarty, "Hand-held Based Near-infrared Optical Imaging Devices: A Review", *Medical Engineering & Physics* 31 (2009) 495–509.
- [11] H. Matsuyama, H. Asama, and M. Otake, "Design of differential Near-Infrared Spectroscopy based Brain Machine Interface", The 18th IEEE International Symposium on Robot and Human Interactive Communication Toyama, Japan, Sept. 27-Oct. 2, 2009.
- [12] Mamoru Tamura, Yoko Hoshi" Fumihiko Okada, "Localized Near-Infrared Spectroscopy and Functional Optical Imaging Of Brain Activity", *Phil. Trans. R. Soc. Lond. B* (1997) 352, 737±742, # 1997 The Royal Society, Printed in Great Britain.
- [13] Farzin Irani, Steven M. Platek, Scott Bunce, Anthony C. Ruocco, Douglas Chute, "Functional Near Infrared Spectroscopy (fNIRS): An Emerging Neuroimaging Technology with Important Applications for the Study of Brain Disorders", *The Clinical Neuropsychologist*, Volume 21, Issue 1 January 2007, pages 9 – 37.
- [14] Tomi Heinonen, Antti Lahtinen, Veikko Hakkinen, "Implementation of Three-Dimensional EEG Brain Mapping", *Computers and Biomedical Research* 32, 123–131 (1999).
- [15] K. Jerbi, J.R. Vidal, J. Mattout, E. Maby, F. Lecaigard, T. Ossandon, C.M. Hamamé, S.S. Dalal, R. Bouet, J.-P. Lachaux, R.M. Leahy, S. Baillet, L. Garnero, C. Delpuech, O. Bertrand, "Inferring hand movement kinematics from MEG, EEG and intracranial EEG: From brain-machine interfaces to motor rehabilitation", *IRBM* 32 (2011) 8–18.
- [16] Yaroslav O. Halchenko, Stephen Jos´e Hanson, Barak A. Pearlmutter, "Multimodal Integration: fMRI, MRI, EEG, MEG", Appears as pages 223-265 of *Advanced Image Processing in Magnetic Resonance Imaging*, Dekker, book series on Signal Processing and Communications, ISBN 0824725425, 2005.
- [17] Mark E. Pflieger, Randall L. Barbour, "Multimodal Integration of fMRI, EEG, and NIRS".
- [18] D. Mantini, L. Marzetti, M. Corbetta, G. L. Romani, C. Del Gratta, "Multimodal Integration of fMRI and EEG Data for High Spatial and Temporal Resolution Analysis of Brain Networks", *Brain Topogr* (2010) 23:150–158.
- [19] Eduardo Mart´inez-Montes, Pedro A. Valde´s-Sosa, Fumikazu Miwakeichi, Robin I. Goldman, Mark S. Cohen, "Concurrent EEG/fMRI analysis by multiway Partial Least Squares", *NeuroImage* 22 (2004) 1023–1034.
- [20] N. Nagdyman, T. P. K. Fleck, P. Ewert, H. Abdul-Khaliq, M. Redlin, P. E. Lange, "Cerebral oxygenation measured by near-infrared spectroscopy during circulatory arrest and cardiopulmonary resuscitation", *British Journal of Anaesthesia* 91 (3): 438±42 (2003).
- [21] NJ Ray, ML Kringelbach, N Jenkinson, SLF Owen, P Davies, S Wang, N De Pennington, PC Hansen, J Stein, TZ Aziz, "Using magnetoencephalography to investigate brain activity during high frequency deep brain stimulation in a cluster headache patient", *Biomedical Imaging and Intervention Journal*, doi: 10.2349/biij.3.1.e25
- [22] R. Labounek, M. Lamoš, R. Mareček, J. Jan, "Analysis of Connections between Simultaneous EEG and fMRI Data", *IWSSIP 2012*, 11-13 April 2012, Vienna, Austria, ISBN 978-3-200-02328-4.
- [23] Herve´ F. Achigui, Mohamad Sawan, Christian J.B. Fayomi, "A monolithic Based NIRS Front-end Wireless Sensor", *Microelectronics Journal* 39 (2008) 1209–1217.
- [24] Emily B.J.Coffey, Anne-MarieBrouwer, EllenS.Wilschut, JanB.F.vanErp, "Brain-Machine Interfaces In Space: Using Spontaneous Rather Than Intentionally Generated Brain Signals", *Acta Astronautica* 67 (2010) 1–11, doi:10.1016/j.actastro.2009.12.016

- [25] Stephane Perrey, Thibaud Thedon, Thomas Rupp, "NIRS in ergonomics: Its application in industry for promotion of health and human performance at work", International Journal of Industrial Ergonomics 40 (2010) 185–189.
- [26] Siamac Fazli, Jan Mehnert, Jens Steinbrink, Gabriel Curio, Arno Villringer, Klaus-Robert Müller, Benjamin Blankertz, "Enhanced Performance By A Hybrid NIRS-EEG Brain Computer Interface", NeuroImage 59 (2012) 519–529
- [27] Katarzyna Blinowska, Gernot Müller-Putz, Vera Kaiser, Laura Astolfi, Katrien Vanderperren, Sabine Van Huffel, Louis Lemieux, "Multimodal Imaging of Human Brain Activity: Rational, Biophysical Aspects and Modes of Integration", Computational Intelligence and Neuroscience Volume 2009, doi:10.1155/2009/813607.



**Revati Shriram** received the B.E. degree in Instrumentation and Control from University of Pune, M.S. in Electrical Engineering from Rose-Hulman Institute of Technology, Indiana, USA. She is currently working towards the Ph.D. degree at Sathyabama University,

Chennai. She is currently working as an Assistant Professor in MKSSS's Cummins College of Engineering for Women, Pune, INDIA.



**Dr. M. Sundhararajan** received MS degree from Birla Institute of Technology & Science (BITS) Pilani and PhD from Bharathidasan University, Trichy, INDIA. He is currently working as a Principal in Shri Laxmi Ammal College of Engineering, Chennai, INDIA



**Nivedita Daimiwai** received the B.E. and M.E. degree in Biomedical Instrumentation from University of Pune. She is currently working towards the Ph.D. degree at Sathyabama University, Chennai. She is currently working as an Assistant

Professor in MKSSS's Cummins College of Engineering for women, Pune, INDIA.

# Applications of fMRI for Brain Mapping

Nivedita Daimiwal<sup>1,2</sup>

<sup>1</sup>Research Scholar, Sathyabama  
University, Chennai, INDIA

<sup>2</sup>Cummins college of Engg. For Women,  
Pune

[nivedita.daimiwal@gmail.com](mailto:nivedita.daimiwal@gmail.com)

Dr.M.Sundhararajan

Principal, Shri Laxmi Ammal Engineering  
College, Chennai, INDIA

[msrajan69@gmail.com](mailto:msrajan69@gmail.com)

Revati Shriram

Cummins College of Engg. For  
Women, Pune, INDIA

[revatishriram@yahoo.com](mailto:revatishriram@yahoo.com)

**Abstract**— Brain-mapping techniques have proven to be vital in understanding the molecular, cellular, and functional mechanisms of the brain. Normal anatomical imaging can provide structural information on certain abnormalities in the brain. However there are many neurological disorders for which only structure studies are not sufficient. In such cases it is required to investigate the functional organization of the brain. Further it is necessary to study the brain functions under normal as well as diseased conditions. Brain mapping techniques can help in deriving useful and important information on these issues. Brain functions and brain area responsible for the particular activities like motor, sensory speech and memory process could be investigated. The authors provide an overview of various Brain Mapping techniques and fMRI signal processing methods.

**Keywords**- Functional MRI (fMRI), Signal Processing, Brain Mapping.

## I. INTRODUCTION

Modern imaging has transformed practice in the clinical neurosciences by providing information about structural abnormalities in the brain non invasively. However many chronic neurological or psychiatric complaints confronted in the clinic (for example pain, movement, disorders, depression and psychosis) are not associated with structural abnormalities that can be detected in an individual patient with current clinical technologies. There are many approaches to measurement of functional changes in brain. While some method directly monitor electrical events in neurons, others by secondary effects of increased neuronal firing rates. Metabolic demand and the requisite changes in blood delivery are useful for localizing the sites and magnitude of brain activity. Several functional brain mapping techniques have been developed over the 3 decades which have revolutionized our ability to map activity in the living brain. [1, 22]

## II. BRAIN MAPPING METHODS

- A. Functional MRI (fMRI): Is one of the techniques that is used to identify the brain regions that are associated with certain motor or sensory tasks. The most common fMRI techniques used to capture functional images of the brain employs Blood Oxygenation level Dependent (BOLD) contrast. In the BOLD effect, a neural activity in the brain caused by some sensory or motor tasks produces localized changes in the blood flow and hence the resulting oxygenation level is subjected to variations. Whenever some task is performed, neuronal in these areas also increases followed by an increase in glucose and oxygen rates. The hemodynamic and metabolic changes associated with brain functions affect the deoxyhaemoglobin contents in the tissue. This gives rise to a contrast that can be detected using the MRI scanner. Functional activation in fMRI studies by mapping changes in cerebral venous oxygen concentration that correlate with neuronal activity. Such approaches require fast two dimensional brain imaging. Using echo planar imaging two dimensional slice data can be acquired in 40 ms with an in plane anatomical resolution of about 1 mm. thus functional maps of the human brain can be obtained without ionizing radiation or the administration of exogenous contrast material.[2]
- B. Positron Emission Tomography (PET): RP (Radio pharmaceuticals) labeled with positron emitting radionuclides are used. Positron emitting radionuclides like C-11, N-13, O-15 & F-18 are used in PET RP, as all these are bio-molecules (F-18 mimics like Hydrogen). One of the stable bio-molecule can be replaced by positron emitting one to study the in-vivo biochemistry. PET plays vital role in Oncology, Cardiology and Neurology. Since all these radioisotopes are cyclotron produced and short lived it



is essential to have the cyclotron in the vicinity. Table 1 shows the RP used in PET.[4]

RP USED IN PET			
RP T <sub>1/2</sub> (min)	Energy Max (KeV)	Range(mm)	
F-18	110	640	2.39
C-11	20	960	4.108
N-13	10	1190	5.39
O-15	2	1720	8.2

Table 1: RP used in PET

Two 511 KeV photons, ejected at 180° apart from annihilation of positron, are used for tomographic imaging. Two scintillation detectors which are connected in coincidence circuit are placed 180° apart. The event simultaneously detected (within 6-12 nSec) by these detectors are considered as ‘True’ events. If two photons each generated from different annihilation process interact with two detectors in coincidence simultaneously then they are called as ‘Random’. Scattered and Random events are unwanted since they degrade the quality of image. PET is used to measure cerebral metabolism, blood flow and volume, oxygen utilization, neurotransmitter synthesis, and receptor binding. The spatial resolution of PET is approximately 5 mm/voxel. [2]

**B. Single Photon Emission Tomography (SPECT):** SPECT uses radiopharmaceuticals administered intravenously or by inhalation to evaluate function in human brain. These radiopharmaceuticals incorporate isotopes including xenon -133, iodine-123, technetium-99m, and others that emit single photon radiation, most typically in the form of gamma rays. SPECT techniques have a current resolution of approximately 9mm/voxel.[2]

**C. Electroencephalography (EEG):** The signals reflect neuronal activity in the superficial layer of the cerebral cortex and the accompanying distortion by volume conductance within tissue and through the skull. Spatial resolution of the technique is determined by the density of electrode placements but typically is on the order of a few square centimeters at the cortical surface. [2, 3]

**D. Magnetoencephalography (MEG):** Takes advantage of the fact that the weak electrical fields in the brain that are detected by EEG also induce a magnetic field that can be externally measured. The extremely low magnitude of these fields requires the use of supercooled devices in rooms that are isolated from the external magnetic and electrical environment. Since

magnetic rather than electrical fields are detected using MEG, distortion caused by the effects of the skull are eliminated. EEG and MEG has a temporal resolution that is in the millisecond time frame. [2, 3]

**E. Optical Intrinsic Imaging Techniques:** Optical imaging of intrinsic signals maps the brain by measuring intrinsic activity related changes in tissue reflectance, functional physiological changes in tissue reflectance. Functional physiological changes, such as increases in blood volume, hemoglobin oxymetry changes, and light scattering changes, result in intrinsic tissue reflectance changes that are exploited to map functional brain activity. [2]

fMRI is a non invasive method for investigating the structure and function of the brain. It has good temporal and spatial resolutions and it is therefore possible to carry out an fMRI experiment in a repetitive manner. The sensitivity that is possible with fMRI is sufficient for detecting the transient changes in the deoxyhaemoglobin content.[1]

### III. TYPICAL fMRI EXPERIMENT

An fMRI experiment can be performed on the same 1.5 T MR scanner that is used for routine work. A fast MR imaging technique such as Echo-planar imaging (EPI) [5] is employed in order to detect the neural activity and the resulting oxygenation levels. It is important here that a single image obviously does not give any functional information. In fact, it is the variation of the image intensity levels when recorded with respect to time that contains the desired functional information. Therefore in fMRI, a number of images of the brain are recorded consecutively with respect to time in a single fMRI experiment. This is shown in figure 1. [1]

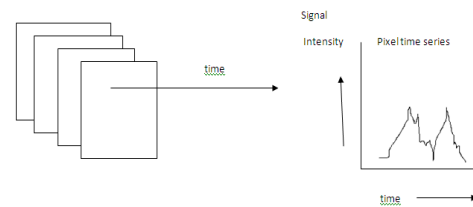

Figure 1: Sequence of Images Recorded with Respect to Time in fMRI and a Pixel Time Series [1]

fMRI is a relative technique in the sense that it compares the images taken during two different states of the task. During the ON state the subject performs some task (the activation state) where as no task is performed during OFF state (the base line state), several such cycles of activation and a baseline signal.

Essentially the signal is determined by the difference between the intensities of the images recorded during the ON state and the intensities recorded during the OFF state. Images recorded during the activation periods and those recorded during the baseline states are then compared. Typically a mean difference image is formed and then tests for statistical significance are carried out to obtain the activation maps. Activation maps show the brain regions that are responsible for a given sensory or motor task. This provides a meaningful picture of the neural activity from the perspective of the brain function.

#### IV. FMRI SIGNAL PROCESSING METHODS

There are a number of signal processing methods useful in processing the fMRI data:

Bendettini et.al. [6] have suggested a method in 1993 that uses both time and frequency domain information also known as temporal spatial and spectral spatial representation. Temporal cross correlation function, Fourier analysis and thresholding techniques are used for data processing. After observing the cross correlation of the time series with the stimulus function, the correlation coefficient for each pixel is calculated and then mapped onto a correlation coefficient map.

In 1994, Friston et.al [7] described a linear model for the haemodynamic response present in an fMRI time series. Simple model of a linear time invariant system based on convolution. The problem was to select the haemodynamic response function so that the convolution of the stimulus function with the haemodynamic response would give the activation signal. Friston et.al [8][9] explained how to model and detect the activations in fMRI time series in 1995. Worsley and Friston described statistical parametric mapping (SPM) that uses a generalized linear model (GLM) operating at each voxel. The aim of the problem that was described in [7] was to estimate the parameter  $\beta$  of the linear model.

$$x = \beta G + e$$

Where  $x$  is the unsmoothed time series and  $e$  the error vector whose components are independent and normally distributed with zero mean and variance 1. This model consists of a design matrix that is common to all the voxels and set of parameter estimates that are voxel specific. The design matrix contains the information about the activation paradigm and the confounding variables. The data that is spatially smoothed using a Gaussian filter and the GLM are

fitted to each voxel. Then a  $t$ -statistic is used for detecting the significantly activated pixels.

In 1996, Bullmore et.al. Investigated statistical methods for the estimation and inference of the fMRI data [10]. They have suggested that the haemodynamic response differs from location to location and that the haemodynamic response delay is spatially varying.

In 1997, K.J Worsley [11] described a new method based on multivariate linear models that could overcome the drawbacks of the methods that used Scaled Subprofile Models (SSM), Singular Value Decomposition (SVD), Partial Least Squares (PLS) And Canonical Variates Analysis. A model that incorporates a spatially varying haemodynamic response. Use of the Discrete Fourier Transform (DFT) of fMRI time series at each voxel was made for analyzing the fMRI data set. In 1998,

Ogawa et.al [12] discussed the various aspects of characterizing the functional MRI elaborating the relation between MRI signals and neural events. Addressing the issue of activation signal detection, Ruttiman and Unser et.al [13] in 1998, used the Discrete Wavelet Transform of the mean difference image in the spatial domain and then applied statistical analysis for obtaining the activation map. Periodicity assumption of an fMRI time series model was proposed by Babak A. Ardekani and Iwao Kanno [14] and a truncated Fourier series was used in their model.

A periodic signal detection method for fMRI data was proposed by Lars Kai Hansen, and Jan Larsen[15]. Their method used a Bayesian framework to detect periodic components in the fMRI data. Assessment of fMRI activation signal detection in the wavelet domain with different wavelets was reported by M.Desco et.al [16]. A newer approach for improving the signal to noise ratio for fMRI data analysis was demonstrated by Muller et.al [17]. A hierarchical clustering analysis method was used to select a cluster of pixels to improve the signal to noise ratio.

Cluster analysis using spectral peak statistics for selecting and testing the significance of activated fMRI time series was reported in the literature by Jarmasz and Somorjai [18]. The application of periodic stimulus, power spectrum ranked independent component analysis of periodic fMRI paradigm was carried out by Mortiz et.al [19]. The fundamental frequency of the periodic stimulus was considered and hence it again resembles purely a sinusoidal based approach. Ranking of spatial ICA components by magnitude contribution at this frequency of the stimulus was used for the

detection purpose. Figure 2 shows the activation map. Colour pixels indicate the activated regions in the brain.

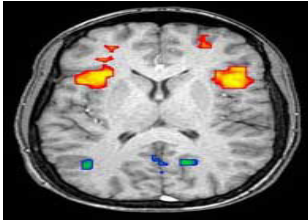

Figure 2: Activation map for one of the slices [20]

#### V. CLINICAL APPLICATIONS

- Examine the anatomy of the brain.
- Determine precisely which part of the brain is handling critical functions such as thought, speech, movement and sensation, which is called brain mapping.
- Help assess the effects of stroke, trauma or degenerative disease (such as Alzheimer's) on brain function.
- Monitor the growth and function of brain tumors.
- Guide the planning of surgery, radiation therapy, or other surgical treatments for the brain. [20][2]

#### VI. CONCLUSION

Neural activity and functional studies of the brain can be investigated with modalities like Positron Emission Tomography (PET), Single photon Emission Computed Tomography (SPECT), Magnetic Encephalography (MEG), and optical Imaging. All these modalities are compared briefly. fMRI is a non invasive method for investigating the structure and function of the brain. It has good temporal and spatial resolutions and it is therefore possible to carry out an fMRI experiment in a repetitive manner. fMRI based investigations, because of the safety, wide availability and extraordinary flexibility in terms of the application of this non ionizing imaging approach. Most recently, fMRI has emerged as a promising new extension of the technology for clinical neuroimaging.

#### ACKNOWLEDGMENT

The authors are grateful to Dr. Madhuri Khambete and Prof A. D. Gaikwad for their motivation, and help towards the completion of this paper, as well as for providing valuable advice.

We would also like to thank our colleagues from Instrumentation and Control Dept. of Cummins College of

Engineering for Women for their feedback during the discussions.

#### REFERENCES

- [1] "Functional Magnetic Resonance Imaging", novel transform method, Ajay V.Deshmukh, Vikram M.Gadre.
- [2] "Brain Mapping the Methods", Arthur W. Toga, John C. Mazziotta
- [3] Dale, A.M., and Sereno, M.I. (1993). "Improved localization of critical activity by combining EEG and MEG with MRI cortical surface reconstruction – A linear approach" *J.cognit.Neurosci.* 5, 162-176.
- [4] Frackowiak, R.S., and Friston, K.J. (1994). Functional neuroanatomy of the human brain: Positron Emission tomography-A new neuroanatomical technique. *J.Anat.* 184, 211-225.
- [5] Michal K.stehling, Robert turner, Peter Mansfield, "Echo-planar Imaging Magnetic resonance imaging in a fraction of second", *Science*, vol.254, pp.44-49.
- [6] P.A Bendettini, A.Jesmanowicz, E.C. Wong and J.S.Hyde, "Processing strategies for time course data sets in functional MRI of the human brain", *Magn.Reson.Med.* vol.30, pp.161-171, 1993.
- [7] K.J.Friston, P.Jezzard and R.Turner, "Analysis of functional time series", *Hum. Brain Mapp.* Vol.1, pp.153-171, 1994.
- [8] K.J.Friston, A.P.Holmes, J.B.Polin, B.J.Grasby, C.R.Williams, R.S.J.Frackowiak, nad R.Turner, "Analysis of time series Revisited", *Neuroimage*, vol.2, pp.45-53, 1995.
- [9] K.J.Friston, A.P.Holmes, K.J.Worsley, J.B.pline, C.D.frith, and R.S.J.Frackowiak, "Statistical Parametric Maps In Functional Imaging: A Generalized Linear Approach". *Human Brain Map.* Vol.2, pp.189-210, 1995.
- [10] E.T.Bullmore, M.J.Brammer, S.C.R.williams, S.Rabe-Henketh, N.Janot, A.david, et.al, "statistical Methods of estimation and Inference for Functional MR Image Analysis", *Magn.Reson.Med.*, vol.35, pp 261-277, 1996.
- [11] K.J.Worsley, J.B.Poline, K.J.Friston, and A.C.Evans, "Characterizing the response of PET and fMRI data using multivariate linear models", *Neuroimage*, vol.6, pp.305-319, 1997.
- [12] S.Ogawa, R.S.Menon, S.G.Kim, and K. Ugurbil, "On the Characterizing o Functional Magnetic Resonance Imaging of the Brain", *Annu.Rev.Biomol.Struct.*, vol.27, pp.447-474, 1998.
- [13] Urs.E.Ruttimann, Michael Unser, Robert R.Rawlings, Daniel Rio, nick R.Ramsey, Venkata S.Mattay, Dniel W.Hommer, Oseph A.frank, and Daniel R.Wienberger, "Statistical Analysis of functional MRI data in the Wavelet domin", *IEEE Trans.Med.Imag.*, vol.17, No2, pp.142-153, 1998
- [14] Babak A.Ardekani, and Iwao Kanno, " Statistical methods for detection activation regions in functional MRI brain", *Mag.Reson.Imag.*, Vol 16, No10, pp.1217-1255, 1998.

- [15]Lars Kai Hansen, Nielsen and Jan Larsen,"Exploring fMRI Data for periodic Signal Components", *AI in medicine*, Vol25,no1,pp.35-44,2002
- [16]M.Desco, J.A.Hernandez, A.Santosh and M.Brammer,"Multiresolution analysis in fMRI: "Sensitivity and Specificity in the Detection of Brain Activity", *Human Brain Map.*, vol.14,pp.16-27,2001.
- [17]H.P.Muller, E.Kraft A.Lodolph, S.N.Erne, "New methods in fMRI Analysis" *IEEE Engg.Med. and Bio.*, pp134-142,2002
- [18] M.Jarmasz, R.L. Somorjai," Exploring regions of interest with clusters analysis using a spectral peak statistic for selecting and testing the significance of fMRI activation time series" *AI in Medicine*,VOL.25,45-67,2002
- [19] Chad H.Moritz, Baxter P.Rogers, and M.Elizabeth Meyerand,"Power spectrum ranked independent component analysis of a periodic fMRI complex Motor paradigm", *Human Brain Mapping*,vol.18,pp.111-122,2003.
- [20] "Functional Brain Mapping", E. Mark Haacke, Ph.D.Washington University, St. Louis
- [21] *Brain-Mapping Techniques for Evaluating Post stroke Recovery and Rehabilitation: A Review*
- [22]"Applications of fMRI in translational medicine and clinical practice", Paul M.Matthew, Garry D.Honey and Edward T.Bullmore, September 2006, volume7.



**Revati Shriram** received the BE Degree in Instrumentation and Control from University of Pune, MS in Electrical Engineering from Rose-Hulman Institute of Technology, Indiana, USA and she is currently working towards the PhD from Sathyabama University, Chennai.

She is currently working as an Assistant Professor in MKSSS's Cummins College of Engineering for Women, Pune, INDIA



**Nivedita Daimiwal** received the B.E and M.E Degree in Biomedical Instrumentation from Pune University. She is currently working towards the PhD from Sathyabama University, Chennai. She is currently working as an Assistant Professor in MKSSS's Cummins College of Engineering for women, Pune, India.



**Dr.M.Sundararanjan** received the M.S Degree from Birla Institute of Technology & Science (BITS), Pilani and PhD from Bharathidasan University, Trichy, INDIA. He is Currently Principal in Shri Laxmi Ammal College of Engineering, Chennai.

# Performance Evaluation of Orthogonal Frequency Division Multiplexing (OFDM) based Wireless Communication System with implementation of Least Mean Square Equalization technique

*Farhana Enam*

Assistant Professor

Dept. of Information & Communication Engineering  
University of Rajshahi, Rajshahi,  
Bangladesh

*Md. Ashrafur Islam*

Lecturer

Dept. of Information & Communication Engineering  
University of Rajshahi, Rajshahi, Bangladesh  
e-mail: ras5615@gmail.com

*Md. Arif Rabbani*

Dept. of Information & Communication Engineering  
University of Rajshahi, Rajshahi,  
Bangladesh

*Sohag Sarkar*

Dept. of Information & Communication Engineering  
University of Rajshahi, Rajshahi,  
Bangladesh

**Abstract**— Orthogonal Frequency Division Multiplexing (OFDM) has recently been applied in wireless communication systems due to its high data rate transmission capability with high bandwidth efficiency and its robustness to multi-path delay. Fading is the one of the major aspect which is considered in the receiver. To cancel the effect of fading, channel estimation and equalization procedure must be done at the receiver before data demodulation. This paper mainly deals with pilot based channel estimation techniques for OFDM communication over frequency selective fading channels. This paper proposes a specific approach to channel equalization for Orthogonal Frequency Division Multiplex (OFDM) systems. Inserting an equalizer realized as an adaptive system before the FFT processing, the influence of variable delay and multi path could be mitigated in order to remove or reduce considerably the guard interval and to gain some spectral efficiency. The adaptive algorithm is based on adaptive filtering with averaging (AFA) for parameter update. Based on the development of a model of the OFDM system, through extensive computer simulations, we investigate the performance of the channel equalized system. The results show much higher convergence and adaptation rate compared to one of the most frequently used algorithms - Least Mean Squares (LMS)

**Keywords**- LMS (Least Mean Square), Adaptive Equalizer, OFDM, Fading Channel, AWGN Channel)

## I. INTRODUCTION

Multimedia wireless services require high data-rate transmission over mobile radio channels. Orthogonal Frequency Division Multiplexing (OFDM) is widely considered as a promising choice for future wireless communications systems due to its high-data-rate transmission capability with high bandwidth efficiency. In OFDM, the entire channel is divided into many narrow subchannels, converting a frequency-selective channel into a collection of frequency-flat channels[1]. Moreover, intersymbol interference (ISI) is avoided by the use of cyclic prefix (CP), which is achieved by extending an OFDM symbol with some portion of its head or tail [2]. In fact, OFDM has been adopted in digital audio broadcasting (DAB), digital video broadcasting (DVB), digital subscriber line (DSL), and wireless local area network (WLAN) standards such as the IEEE 802.11a/b/g/n [3–6]. It has also been adopted for wireless broadband access standards such as the IEEE 802.16e [7, 8, 9], and as the core technique for the fourth-generation (4G) wireless mobile Communications [10]. To eliminate the need for channel estimation and tracking, Quadrature phase-shift keying (QPSK) can be used in OFDM systems. However, this result in a 3 dB loss in signal-to-noise ratio (SNR) compared with coherent demodulation such as phase-shift keying (PSK) [11]. The performance of OFDM systems can be improved by allowing for coherent demodulation when an accurate channel estimation technique is used. Channel estimation techniques for OFDM systems can be grouped into two categories: blind

and non-blind. These blind channel estimation techniques may be a desirable approach as they do not require training or pilot signals to increase the system bandwidth and the channel throughput; they require, however, a large amount of data in order to make a reliable stochastic estimation. Therefore they suffer from high computational complexity and severe performance degradation in fast fading channel [12, 13, 14]. On the other hand, the non-blind channel estimation can be performed by either inserting pilot tones into all of the subcarriers of OFDM symbols with a specific period or inserting pilot tones into some of the subcarriers for each OFDM symbol [18, 19]. In case of the non-blind channel estimation, the pilot tones are multiplexed with the data within an OFDM symbol and it is referred to as comb-type pilot arrangement. The comb-type channel estimation is performed to satisfy the need for the channel equalization or tracking in fast fading scenario, where the channel changes even in one OFDM period [15]. The main idea in comb-type channel estimation is to first estimate the channel conditions at the pilot subcarriers and then estimates the channel at the data subcarriers by means of interpolation. The estimation of the channel at the pilot subcarriers can be based on Least Mean Square (LMS)[17].

The paper organizes as follows: section 2 describes the LMS (Least Mean Square) algorithm which is used in this research. The proposed model is described in section 3 as system description. In section 4, the simulation results of the proposed Least Mean Square equalization technique system are presented.

## II. LMS (LEAST MEAN SQUARE) ALGORITHM

The Least Mean Square (LMS) algorithm is a gradient-based method of steepest decent [20]. LMS algorithm uses the estimates of the gradient vector from the available data. LMS incorporates an iterative procedure that makes successive corrections to the weight vector in the direction of the negative of the gradient vector which eventually leads to the minimum mean square error [21-24]. Compared to other algorithms LMS algorithm is relatively simple; it does not require correlation function calculation nor does it require matrix inversions.

Consider a Uniform Linear Array (ULA) with N isotropic elements, which forms the integral part of the adaptive beamforming system as shown in the figure below.

The output of the antenna array  $x(t)$  is given by,

$$X(t) = s(t)a(\theta_0) + \sum u(t)a(\theta_i) + n(t)$$

where,  $s(t)$  denotes the desired signal arriving at angle  $\theta_0$  and  $u_i(t)$  denotes interfering signals arriving at angle of incidences  $\theta_i$  respectively,  $a(\theta_0)$  and  $a(\theta_i)$  represents the steering vectors for the desired signal and interfering signals respectively.

Therefore it is required to construct the desired signal from the received signal amid the interfering signal and additional noise  $n(t)$ .

From the method of steepest descent, the weight vector equation is given by [16],

$$W(n+1) = w(n) + \frac{1}{2} \mu [-\Delta(E\{e^2(n)\})]$$

Where  $\mu$  is the step-size parameter and controls the convergence characteristics of the LMS algorithm;  $e^2(n)$  is the mean square error between the beamformer output  $y(n)$  and the reference signal which is given by,

$$e^2(n) = [d^*(n) - w^h x(n)]^2$$

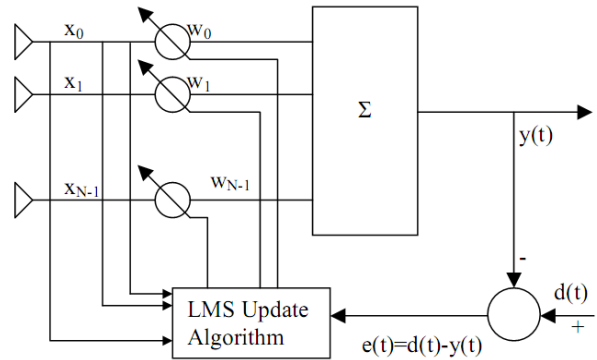

Figure 1: LMS adaptive beamforming network

The gradient vector in the above weight update equation can be computed as  $\nabla_w (E\{e^2(n)\}) = -2r + 2Rw(n)$ . In the method of steepest descent the biggest problem is the computation involved in finding the values  $r$  and  $R$  matrices in real time. The LMS algorithm on the other hand simplifies this by using the instantaneous values of covariance matrices  $r$  and  $R$  instead of their actual values i.e.

$$R(n) = x(n)x^h(n)$$

$$r(n) = d^*(n)x(n)$$

Therefore the weight update can be given by the following equation,

$$w(n+1) = w(n) + \mu x(n)[d^*(n) - x^h(n)w(n)] = w(n) + \mu x(n)e^*(n)$$

The LMS algorithm is initiated with an arbitrary value  $w(0)$  for the weight vector at  $n=0$ . The successive corrections of the weight vector eventually leads to the minimum value of the mean squared error [25, 26]. Therefore the LMS algorithm can be summarized in following equations:

$$\text{Output, } y(n) = w^h x(n)$$

$$\text{Error, } e(n) = d^*(n) - y(n)$$

$$\text{Weight, } w(n+1) = w(n) + \mu x(n)e^*(n)$$

### III. SIMULATION MODEL

In this section, the Wireless Communication system simulation with Least Mean Square (LMS) equalization technique model to be implemented has been discussed thoroughly and all related assumptions have been stated clearly and justified. The implemented model needs to be realistic as possible in order to get reliable results. It is ought to be mentioned here that the real communication systems are very much complicated and due to non availability of the algorithms to simulate the performance evaluation of their various sections, generally, simulations are made on the basis of some assumptions to simplify the communication system(s) concerned.

Figure-2 shows a simulation model for the Wireless Communication system simulation with Least Mean Square (LMS) equalization technique. It consists of various sections. A brief description of the simulated model is given below:

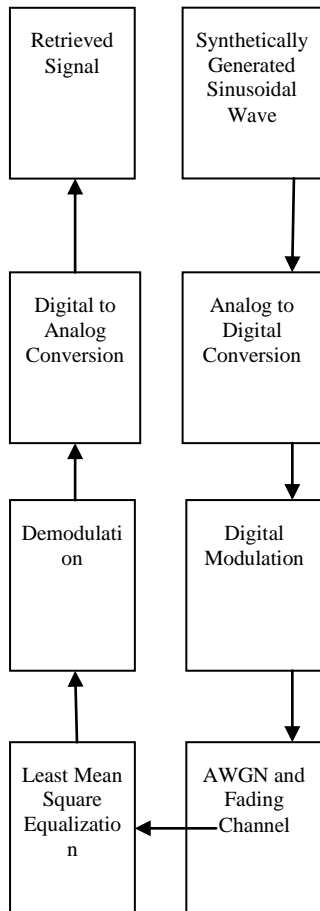

Figure-2: A block diagram of Wireless Communication system simulation with Least Mean Square (LMS) equalization technique.

The block diagram of the simulated system model is shown in Figure -2. The synthetically generated sinusoidal wave is first converted to digital bit stream. The digital signal is then fed to the input of the modulator. Then the data are modulated

according to QPSK modulation scheme. The effect of AWGN and fading Channel are then introduced into the modulated wave. A Least Mean Square (LMS) equalization technique is used to remove the effect of AWGN and Fading channel. The output of the equalizer is then fed to the input of demodulator where the demodulation is done. Finally, the demodulated signal is converted to analog signal as the retrieved sinusoidal signal.

Table 1: The parameters of simulation model.:

Parameters	values
Number Of Bits	44000
Number Of Subscribers	200
FFT Size	256
CP	1/4
Coding	Convolutional Coding(CC), Reed-Solomon(RS) Coding
Constraint length	7
K-factor	3
Maximum Doppler shift	100/40Hz
Modulation	16-QAM, 64-QAM, 256-QAM, QPSK, 16-PSK, 64-PSK, 256-PSK
Frequency used for synthetic data	1 KHz
Sampling Rate	4 KHz
SNR	0-50 dB
Wireless channel	AWGN and Fading Channel
Channel Coefficients	[.986; .845; .237; .123+.31i]

### IV. SIMULATION RESULT

This section of the chapter presents and discusses all of the results obtained by the computer simulation program written in Matlab7.5, following the analytical approach of a wireless communication system considering AWGN and Fading channel. A test case is considered with the synthetically generated data. The results are represented in terms of bit energy to noise power spectral density ratio ( $E_b/N_0$ ) and bit error rate (BER) for practical values of system parameters.

By varying SNR, the plot of  $E_b/N_0$  vs BER was drawn with the help of “semilogy” function. The Bit Error Rate (BER) plot obtained in the performance analysis showed that model works well on Signal to Noise Ratio (SNR)

less than 50 dB. Simulation results in figure-3 and figure-4 shows the performance of the system over AWGN and fading channels using QPSK, 16-PSK, 64-PSK, 256-PSK, 16-QAM, 64-QAM and 256-QAM modulation schemes respectively.

From figure-2, it is observed that the BER performance of the system with implementation of Least Mean Square algorithm (LMS) in QPSK outperforms as compared to other digital modulations. The system shows worst performance in 256 PSK. For a typical SNR value of 10dB, the system performance is improved by 8.26 dB. It is also noticeable that the system performance degrades with increase of order of modulation.

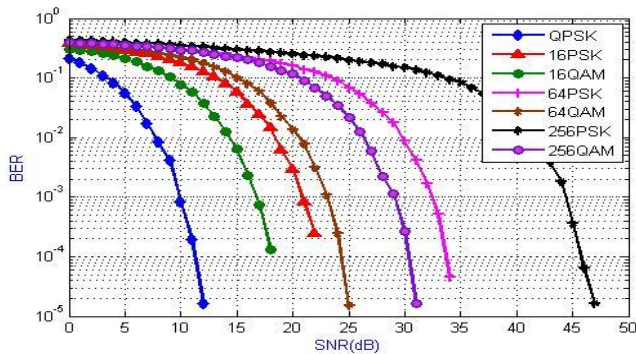

**Figure-2:** BER performance of a Wireless Communication System over AWGN channel.

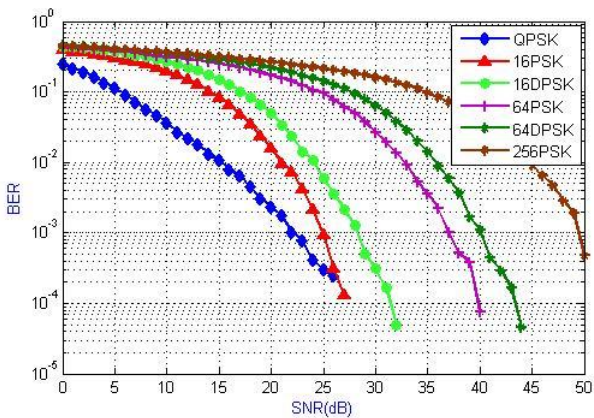

**Figure-3:** BER performance of a Wireless Communication System under different modulation schemes under fading channel

Figure-3 shows the BER performance of a Wireless Communication System under different modulation schemes under fading channel. From figure-3, it is also observed that the BER performance of the system with implementation of Least Mean Square algorithm (LMS) in QPSK is better as compared to other digital modulations. The system shows worst performance in 256 PSK. For a typical SNR value of 10dB, the

system performance is improved by 4.511dB. It is also noticeable that the system performance degrades with increase of order of modulation.

## V. CONCLUSION

In this research work, it has been studied the performance of an OFDM based wireless communication system with implementation of Least Mean square equalization technique and different digital modulation schemes. A range of system performance results highlights the impact of digital modulations in AWGN and fading channels. From the present study it is found that the system performance is improved 7.36dB for QPSK modulation at SNR 9dB, 7.113dB for 64PSK modulation at SNR 31dB, 12.04dB for 64QAM modulation at SNR 22dB, 3.375dB for 16QAM modulation at SNR 15dB and 3.988dB for 256PSK modulation than uncoded situation over AWGN channel.

In the case of fading channel the system performance is improved 4.511dB for QPSK modulation at SNR 10dB, 7.203dB for 16PSK modulation at SNR 25dB, 7.964dB for 64PSK modulation at SNR 37dB, 6.0588dB for 16PSK modulation at SNR 22dB and 11.18dB for 256PSK modulation at SNR 47dB than uncoded situation.

In the present study, it has been observed that the OFDM, an elegant and effective multi carrier technique sed FEC encoded wireless communication system can overcome multipath distortion. In Bangladesh, WiMAX technology is going to be implemented and its physical layer is based on OFDM. The present work can be extended in MIMO-OFDM technology to ensure high data rate transmission.

## REFERENCES

- [1] [Engels, M., 2002] M. Engels. Wireless OFDM Systems: How to Make Them Work? Kluwer Academic Publishers, 2002.
- [2] IEEE Standard 802.11a 1999, Wireless LAN Medium Access Control (MAC) and Physical Layer (PHY) Specifications: High-speed Physical Layer in the 5GHz Band. IEEE, September 1999. IEEE Standard 802.11b 1999.
- [3] [IEEE, 1999] Wireless LAN Medium Access Control (MAC) and Physical Layer (PHY) Specifications: High-speed Physical Layer in the 2.4GHz Band. IEEE, September 1999.
- [4] IEEE Standard 802.11g 2003. Wireless LAN Medium Access Control (MAC) and physical Layer (PHY) Specifications: Future Higher Data Rate Extension in the 2.4 GHz Band. IEEE, September 2003.
- [5] IEEE Standard 802.11n D2.00 2007. Wireless LAN Medium Access Control (MAC) and Physical Layer (PHY) Specifications: Enhancements for Higher Throughput. IEEE, September 2007.
- [6] IEEE Standard 802.16e 2005. Local and Metropolitan Area Networks - Part 16, Air Interface for Fixed Broadband Wireless Access Systems. IEEE, September 2005.
- [7] [Kopman et al, 2002] I. Kopman and V. Roman. Broadband wireless access solutions based on OFDM access in IEEE 802.16. IEEE Commun. Mag., 51(6):96-103, June 2002.
- [8] J. Proakis. Digital Communications. McGraw-Hill, 1989.
- [9] R. Zhang A. P. Petropulu and R. Lin. Blind ofdm channel estimation through simple linear precoding. IEEE Trans. Wireless Commun., 3(2):647-655, Mar. 2004.



- [10] [Athaudage et al, 2004] C. R. N. Athaudage and A. D. S. Jayalath. Enhanced mmse channel estimation using timing error statistics for wireless ofdm systems. *IEEE Trans. Broadcast.*, 50(4), Dec.2004.
- [11] X. You J. Wang B. Han, X. Gao and E. Costa, "An iterative joint channel estimation and symbol detection algorithm applied in OFDM system with high data to pilot power ratio", In Proc. IEEE Int'l. Conf. Commun., volume 3, pages 2076–2080, Anchorage, AK, May 2003.
- [12] F. Gao and A. Nallanathan, "Blind channel estimation for ofdm systems via a generalized precoding", *IEEE Trans Vehicular Technol.*, 56(3):1155–1164, May 2007.
- [13] ] L. Tong and S. Perreau. Multichannel blind identification: From subspace to maximum likelihood methods. In Proc. IEEE, volume 86, pages 1951–1968, Oct. 1998.
- [14] [Muquet et al, 2002] B. Muquet S. Zhou and G. B. Giannakis, "Subspace-based (semi-) blind channel estimation for block precoded space-time ofdm", *IEEE Trans Signal Process.*, 50(5):1215–1228, May 2002.
- [15] R. Zhang "Blind OFDM channel estimation through linear precoding: A subspace approach", In Proc 36th Asilomar Conf, Pacific Grove, CA., pages 631–633, Nov.2002.
- [16] L. Hanzo B. J. Choi, T. Keller and M. Munster. OFDM and MC-CDMA for Broadband Multi-User Communications, WLANs and Broadcasting. Wiley-IEEE Press, Aug.2003.
- [17] [Petropulu et al. 2002] A. P. Petropulu and R. Zhang, "Blind channel estimation for OFDM systems", In Proc. DSP/SPE, Atlanta, GA, pages 366–370, Oct. 2002.
- [18] X. Cai and A. N. Akansu, "A subspace method for blind channel identification in OFDM systems", In Proc. ICC, pages 929–933, New Orleans, LA, Jul. 2000.
- [19] J. Cardoso E. Moulines, P. Duhamel and S. Mayrargue, "Subspace methods for the blind identification of multichannel fir filters", *IEEE Trans. Signal Process.*, 43(2):516–525, Feb, 1995.
- [20] R.W. Heath and G. B. Giannakis. Exploiting input cyclostationarity for blind channel identification in ofdm systems. *IEEE Trans. Signal Process.*, 47:848–856, Mar 1999.
- [21] B. Muquet and M. de Courville. Blind and semi-blind channel identification methods using second order statistics for OFDM systems. In Proc. SPAWC, volume 5, pages 170–173, Annapolis, MD, May 1999.
- [22] Z. Ding X. Zhuang and A. L. Swindlehurst, "A statistical subspace method for blind channel identification in OFDM communications", In Proc. ICASSP, volume 5, pages 2493–2496, 2000.
- [23] C. Li and S. Roy, "Subspace-based blind channel estimation for ofdm by exploiting virtual carriers", *IEEE Trans Wireless Commun.*, 2(1):141–150, Jan. 2003.
- [24] [Wu et al. 2003] S. Wu and Y. Bar-Ness. OFDM channel estimation in the presence of frequency offset and phase noise. In Proc. IEEE Int'l. Conf. Commun., pages 3366–70, May 2003.
- [25] S. Roy Y. Song and L. A. Akers, "Joint blind estimation of channel and data symbols in OFDM", In Proc IEEE VTC 2000, volume 1, pages 46–50, Tokyo, 2000.
- [26] Theodore S. Rappaport, "Wireless Communication Principles and Practice", Second Edition, Pearson Education, Inc, 2004, ISBN 81-7808-648-4.

# Microcontroller Based Security System:

An electronic application for fire monitoring and surveillance

Md. Fasiul Alam  
MSc. In Electronic System engineering  
Politecnico di Milano  
Milan, Italy  
Email: [md.fasiul.alam@mail.polimi.it](mailto:md.fasiul.alam@mail.polimi.it)

Helena Bulbul  
Assistant Professor,  
United International University  
Dhaka, Bangladesh  
Email: [helena@eee.uiu.ac.bd](mailto:helena@eee.uiu.ac.bd)

Md. Delwar Hossain  
Assistant communication engineer  
Boishaki International Television Ltd.  
Dhaka, Bangladesh  
Email: [deleardit@gmail.com](mailto:deleardit@gmail.com)

**Abstract**— The importance of electronic security is now an important term in the global world. Due to the lack of modern security equipments we often face problems and lose our valuable assets. Though there are some security system are available in the market but wireless system are not so common and economic to us. Therefore, a Microcontroller Based Security System has been developed to recover that limitation. It can be used for ensuring fire security in Offices, Banks, Apartments, Industry and so on. The system detects the fire fault situation and inform automatically to the desired destination without any human intervention. Microcontroller Based Security System is an intelligent stand alone system with proven performance and stability. The aim of an engineering design is to produce maximum output with minimum cost involved. According to that, our designed system involves low cost yet offers better performance in comparison to other security system available. Microcontroller is the heart in our security system which is interfaced with smoke sensors, SIMCom GSM Module, alarm circuit and LCD display unit. The important feature of the project are it can easily specify the location where the fire occurred and it instructs the SIMCom GSM Module to send SMS to the desired end for taking necessary action immediately. The results obtained stand as a proof of concept for the credibility of implementing wireless based Security System. Achieved result of the project encouraging to us.

**Keywords**-Microcontroller, security, sensors, alarm, GPS, GSM

## I. INTRODUCTION

Recently, applications of Microcontroller [1] based device continue to rise more than ever before. Furthermore, with the increase of that devices application in recent year, the Microcontroller is the only specification targeted at this new market. A Microcontroller is a chip, containing processor, memory and input/output function though in smaller capacity. It is a microprocessor emphasizing high integration, in contrast

to a general purpose microprocessor. In addition to usual arithmetic and logic element of general purpose microprocessor, it integrates additional elements such as read & writes memory for data storage, read only memory for program storage, EEPROM for reprogramming, peripheral device and input and output interface. A few MHz clock speeds Microcontroller often operate at very low speed compared to the modern microprocessor, but this is adequate for typical applications. It consumes relatively low power (mw); it has sleep and wake up options etc. Microcontrollers are frequently used in automatically controlled products and devices such as automobile engine control system, remote controls, office machines, appliances, programmable interval timer, power tools and toys and analog to digital and digital to analog converter etc. By reducing the size, cost and power consumption compared to a design using a separate microprocessor, memory, input/ output device, microcontroller makes it economical to electronically control many more processes. The proposed system offers unparalleled confidence and security thanks to a unique dual-network system that continually monitors our houses. Every houses protected by smart monitoring is constantly monitored in real time from central monitoring station. If an alert is triggered by the system, they'll know about it instantly. The system checks itself continuously to ensure that it's working properly, and that the network connection is functioning properly. That means user can relax, knowing their houses is always connected, protected and safe. Microcontroller is the heart of our designed security system which is interfaced with smoke sensors, GSM Module, alarm circuit and display unit. Smoke sensor sense the smoke particle and give signal to the Microcontroller. Microcontroller test different situation of the smoke detector and gives output to the alarm circuit as well as display unit for different conditions of the security system. The designed system can also easily identify location. The overall objectives of this security system involves: to save our valuable asset, interface a Microcontroller with different electronic devices, to implement the idea with low infrastructure porting to more standard and power-full OS like portable SW architecture, to get area's information automatically without any human intervention, to establish GSM/GPRS Capability.

---

The research project is completed by partial funding from United International University (UIU), Dhaka, Bangladesh.

## II. SYSTEM SETUP

### A. Block Diagram:

In order to fulfill the aim of the project, it is necessary to drive the hardware architecture design based on the understanding of the communication link and to send message. Different hardware components interacting with each other to achieve this goal. In our project, we used ATmega32 Microcontroller [1] which plays a role of heart in the project. It takes decision based on different situations received as logical changes in its port. It is simply a highly integrated chip that contains all the components comprising Controller. Typically this includes a CPU, RAM, ROM, I/O ports, Digital Communication Modules, Timers and other integrated components. The overall design of the project is shown in the fig: 1 block diagram

A smoke detector or smoke alarm [2] is devices that detects smoke and confirm that there is a potential fire. A household smoke detector will typically be mounted in a disk shaped plastic enclosure about 150 mm in diameter and 25 mm thick, but the shape can vary by manufacturer. Because smoke rises, most detectors are mounted on the ceiling or on a wall near the ceiling. To avoid the nuisance of false alarms, most smoke detectors are mounted away from kitchens. To increase the chances of waking sleeping occupants, most homes have at least one smoke detector near any bedrooms; ideally in a hallway as well as in the bedroom itself. Smoke detectors are usually powered by one or more batteries but some can be connected directly to household wiring. Often smoke detectors that are directly connected to household wiring also have a battery as a power supply backup in case the household wiring goes out. It is usually necessary to replace the batteries once a year to ensure appropriate protection. Smoke detectors are placed in different positions in an area.

SIM 508c [3] is a dual band GSM/GPRS engine works on frequencies EGSM 900 MHz/DCS 1800 MHz. SIM508C also supports GPS technology for satellite navigation. SIM508C provides GPRS multi-slot class10 capabilities and supports the GPRS coding schemes CS-1, CS-2, CS-3 and CS4. With a tiny configuration of 50mm x 33mm x 8.8mm, SIM508C can meet almost all the space requirement in our application, such as smart phone, PDA phone, GPS hand-held device and other mobile device, or application of AVL, location service and so on. The physical interface to the mobile application is a 60-pin board to board connector, which provides all hardware interfaces between the module and microcontroller except the RF antenna included two microphone inputs and two speakers' output, charge interface, GSM RF antenna interface with alternative antenna connector and antenna pad, low power consumption, it is integrated with TCP/IP protocol and extended TCP/IP AT command.

### III. WORKING PROCEDURE

In figure 3, the overall schematic connection has shown. Smoke sensors/detectors are placed in different locations which are connected to the Microcontroller input ports. When smoke detector sense smoke, it generate signal which is applied to the port B of Microcontroller.

To maintain logical low (0) at port B of the Microcontroller, initially Port B is connected to ground by a 4.7k resistor. When port B gets logical high signal (1) from the smoke detector at that time a logical change (0 to 1) is occurred at port B of the Microcontroller. Microcontroller continuously scans its port B. When any logical changes (0 to 1) at port B occurred, Microcontroller detects which pin of port B changes its logical state. Suppose smoke detector one to eight's outputs are connected to pin 1 to pin 8 of the port B respectively. Now if detector number three, detector number five and detector number six detect fire, then pins B3, B5 and B6 get logical changes (0 to 1). At that time, Microcontroller executes the following condition in its software routine.

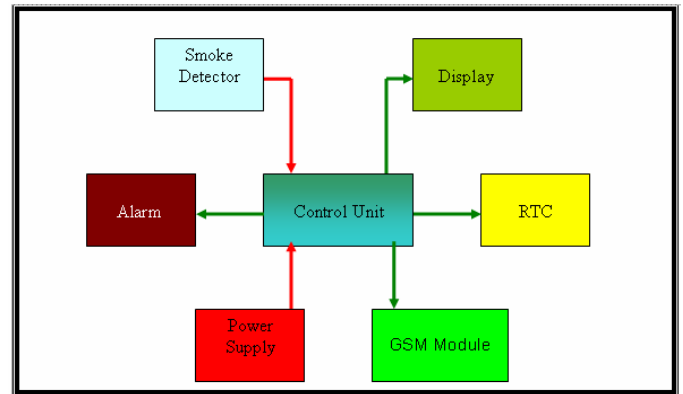

Fig. 1: Block diagram of the project

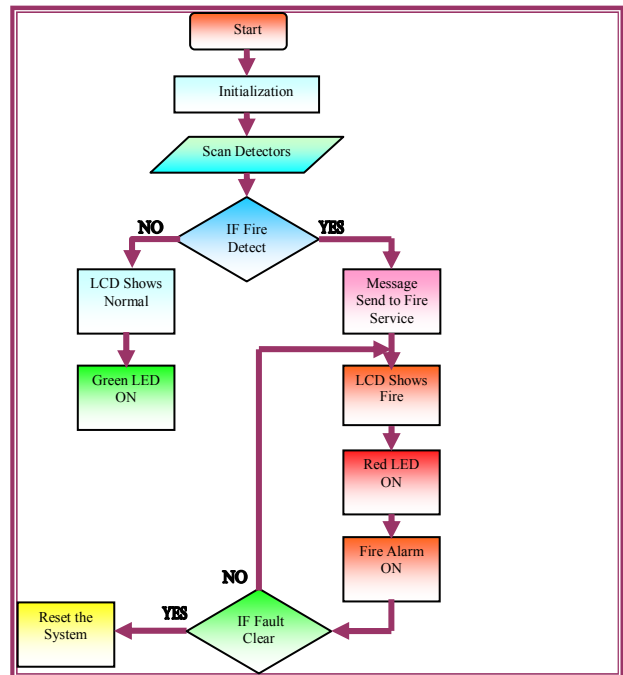

Fig. 2: Flow chart of the project

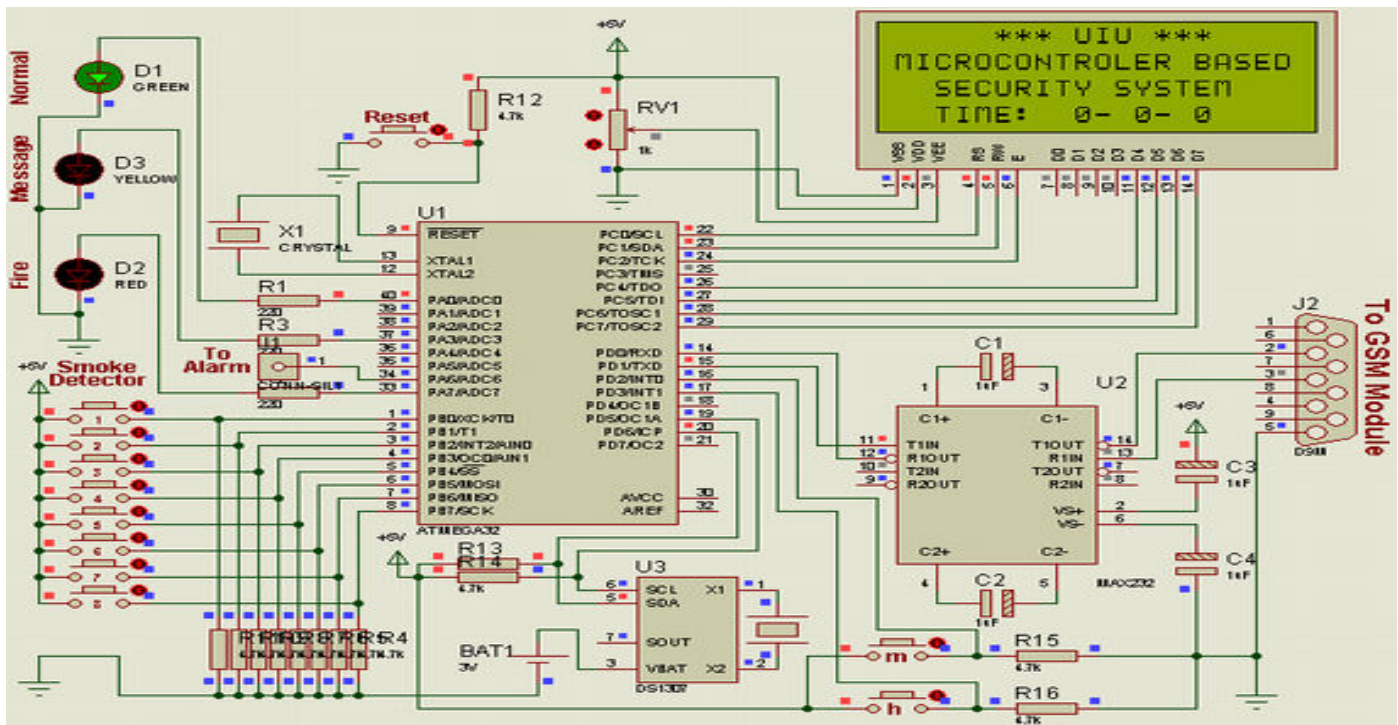

Fig. 3: Simulation Diagram of the Project

```

if (PINB.0==1) {s0=1;}
if (PINB.1==1) {s1=2;}
if (PINB.2==1) {s2=3;}
if (PINB.3==1) {s3=4;}
if (PINB.4==1) {s4=5;}
if (PINB.5==1) {s5=6;}
if (PINB.6==1) {s6=7;}
if (PINB.7==1) {s7=8;}

```

```

lcd_gotoxy(0,3);
sprintf(buffer2,"FIRE:%1u %1u %1u %1u %1u %1u %1u %1u",s0,s1,s2,s3,s4,s5,s6,s7);
lcd_puts(buffer2);

```

If smoke detector number one detects smoke then Microcontroller port B.0 receives a high signal and it stores (1) the value in a variable s0. This s0 will show in the display unit as a smoke detector number one which detects smoke. Again if smoke detector number two detects smoke then Microcontroller port B.1 will get high signal and it store (2) in a variable s1. This s1 will be shown in the display unit as a smoke detector number two which detects smoke. In this way if Microcontroller port B.2, B.3, B.4, B.5, B.6, B.7 will get high signal then it will represent smoke detector three, four, five, six, seven, eight as in the variable s2, s3, s4, s5, s6, s7 respectively. Microcontroller stores these data (s0, s1, s2, s3, s4, s5, s6, s7) in its buffer2 and displays it in the LCD display.

A. Normal condition

The simulated [5] result shows normal condition of the fire security system. It means that none of the detectors detect any smoke. He B. Upon detection of Fire. We press the push button switch 3, 5, 6 which represents the presence of fire in different three locations. Under this situation the display unit shows <<<Fire>>> which means that the smoke detector senses the smoke. The 3, 5, and 6 no. detectors were pushed to observe the situation. The Simulation [5] shown results in the display unit prove that only those detectors detect the fire for which we pressed the switch. At this time red LED is illuminated which is actually used to indicate the fire affected situation of any area. Accordingly, LCD display shows the following strings-

```

*** UIU ***
<<<FIRE>>>
FIRE ALARM ON
FIRE: 0 0 3 0 5 6 0 0

```

C. Message sending when fire detect

Message sending is the most important part in our project. For this purpose, we used a yellow LED in the simulation circuit to indicate SMS sending is taking place. When smoke detector detects fire, the LCD display unit shows the fire information, alarm circuit gives a continuous alarm, and within a few second GSM module is ready to send SMS to the destination centre through the MAX 232 [2]. When module is sending SMS, at that time a yellow LED is illuminated.

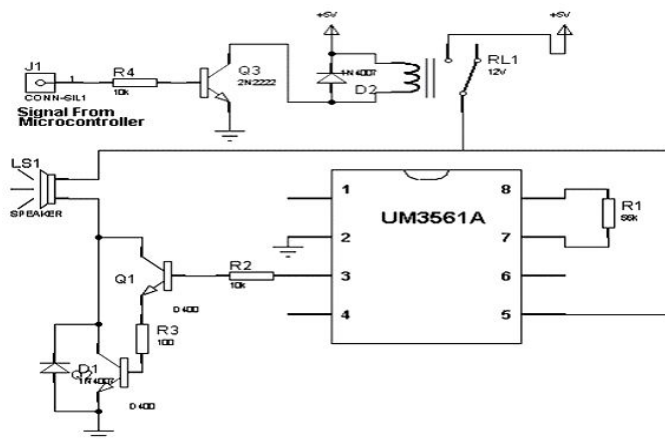

Fig. 4: Alarm Section

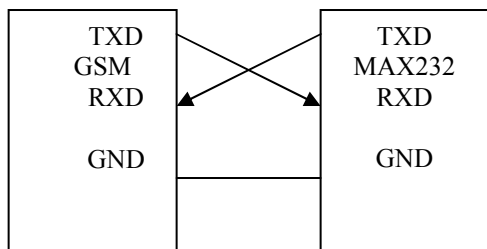

Fig. 5: Connection between GSM module and MAX 232

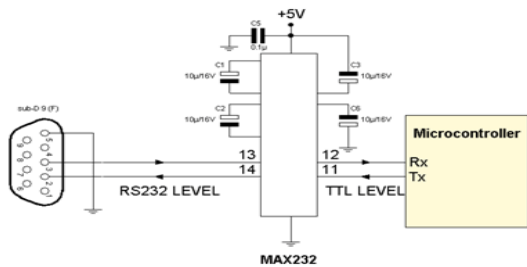

Fig. 6: Connections between Microcontroller and MAX 232

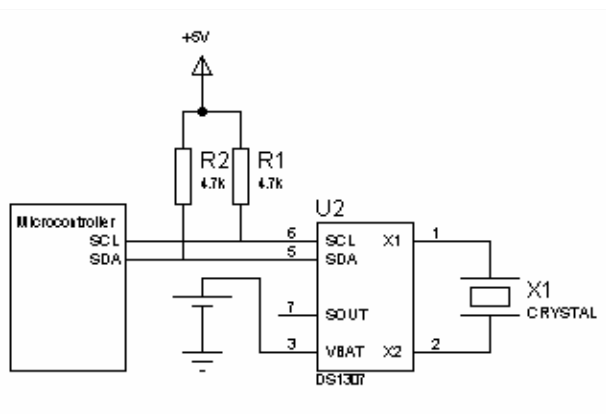

Fig. 7: Connection between DS1307 RTC and Microcontroller

D. When fault is cleared

It means that now there is no fire in the affected area but it still shows the previously affected zones i.e. 3, 5 and 6 no. detector shows in the display for the acknowledgement. At the same time, it also indicates that resetting the system actually keeps off siren of the alarm section as well as return to initial condition of the system.

IV. ALARMING

When smoke detectors detect smoke particles the PA6 pin of the Microcontroller will be at logic high (1) level. Accordingly, the base of the NPN transistor (Q 3) of the alarm unit will get a high signal from the PA6 pin of the Microcontroller. The emitter of this transistor is grounded. So emitter current will flow to the collector. The display unit shows the recommended strings as well as the green LED is illuminated.. Figure 4 shows the alarm circuit. The collector is connected with one terminal of relay where other terminal is connected with the positive power supply (+5 volt). The fire tone generated IC (UM-3561A) is connected to the relay terminal. When relay is ON the pin no. 5 of this IC will get power supply. The UM-3561A IC is used to hold fire alarm tone/music. When it is ON, it generates fire tone. The tone is amplified by a transistor and applied to the loudspeaker so that we can hear the fire alarm siren.

V. SMS SENDING PROCEDURE

A dual band GSM/GPRS engine working on frequencies EGSM 900 MHz/DCS 1800 MHz for SMS sending. To interface SIMCom 508c GSM Module with the Microcontroller, we used MAX 232 dual driver/receiver. SMS sending procedure have shown by the following fig. 5 and 6. The MAX232 is a dual driver/receiver that includes a capacitive voltage generator to supply EIA-232 voltage from a single 5-V supply. Each receiver converts EIA-232 inputs to 5-V TTL/CMOS levels. These receivers have a typical threshold of 1.3 V and a typical hysteresis of 0.5 V, and can accept ±30-V inputs. Each driver converts TTL/CMOS input levels into EIA-232 levels. The MAX 232 is connected with RXD and TXD pins at port D of the Microcontroller. When fire is detected by Microcontroller, the Microcontroller sends the following programming [6] AT commands at GSM module through the MAX 232. In order to get proper timing here we used Teal Time Clock (RTC) which is shown in figure 7.

When fault is cleared, it is needed to reset the system but still need to know the zones which were affected by fire and hence at the time of taking necessary action in clearing the fire, display unit shows the following strings-

\*\*\* UIU \*\*\*  
FAULT CLEAR

RESET THE SYSTEM  
putsf("at+cmgf=1");

```
    putchar(0x0D);
    putsf("at+cmgs="Mobile Number\");
    putchar(0x0D);
    putsf("Text Which Will Be Send In The Destination Centre");
    putchar(0x1A);
```

## V. CONCLUSION

In today's automated world, Microcontroller based devices are more in used. Microcontroller can perform several functions at a time and also can make a circuit small and efficient. Using a Microcontroller, we can compactly and smartly design a circuit and reprogram it whenever we want to modify or upgrade the system. The designed system can easily be used in residence, industry, Base Transceiver Station (BTS), Aero plane and ship etc. for security purpose. Microcontroller based automated control is vital for safety and security and effective operation. In this project, we implemented a very economic security and surveillance system by microcontroller. In future, we would like to incorporate more controlling features to this project to globally monitor the status of various smoke detectors or other electronic sensors which can be done by Internet Protocol (IP).

## VI. ACKNOWLEDGMENT

I would like to give my sincere thanks to Mr. Sharier Alam, Propiter of Xentec technology ltd, Dhaka, Bangladesh, for his valuable verbal guideline in our project

## References

- [1] *Microcontroller Data Manual*, Atmel Semiconductor Products Inc., California, CA, 1984.
- [2] D. Gottuk, Ph.D., *Full-Scale House Fire Experiment for InterFIRE VR*, Report of Test, November 2, 1999, Revised April 10, 2000, Available: [http://www.interfire.org/features/fire\\_experiment.asp](http://www.interfire.org/features/fire_experiment.asp).
- [3] *MSP430 IAR C/C++ Compiler Reference Guide*, Texas Instrument, Dallas, TX 75266-019.
- [4] *Proteus 7.2 Microcontroller Simulation Software*, Labcenter Electronics Ltd., BD235AA, England.
- [5] *Code Vision AVR Microcontroller Programming Software*, HP InfoTech S.R.L., Bucharest, ROMANIA.
- [6] A. Shrinath, A. Emadi, "Electronic Control Units for automotive electrical power systems: communication and networks", *Journal of Automobile Engineering, Proc. of the Institution of Mechanical Engineers*, vol. 218, partD, 2004, UK, pp. 217 – 230.
- [7] N. Kurata, B. F. Spencer, Jr, and M. Ruiz-Sandoval, "Application of Wireless Sensor Mote for Building Risk Monitoring", *IEEE, SECON*, Available on: <http://www.unl.im.dendai.ac>.
- [8] R. C. Luo, K. L. Su, and K. H. Tsai, "Intelligent security robot fire detection system using adaptive sensory fusion method," in *Proc. IEEE Int. Conf. Ind. Electron. Soc.*, 2002, vol. 4, pp. 2663–2668.
- [9] R. C. Luo, S. Y. Lin, and K. L. Su, "A multiagent multisensor based security system for intelligent building," in *Proc. IEEE/SICE/RSJ Int. Conf. Multisensor Fusion Integr. Intell. Syst.*, 2003, pp. 311–316.
- [10] *The Advanced Multi-Criteria Fire Detector*, System Sensors, 3825 Ohio Avenue, St. Charles, IL 60174.
- [11] *Safety and Health Administration*, U.S. Department of Labor, 200 Constitution Ave., N.W.
- [12] A. Neubauer, "Genetic algorithms in automatic fire detection technology," in *Proc. 2nd Int. Conf. Genetic Algorithms Eng. Syst.: Innovations Appl.*, 1997, pp. 180–185.

- [13] Wobschall, D., Prasad, H.S., "Esbu- a sensor bus based on the SPI serial interface", *Proceedings of IEEE Sensors*, Orlando, USA, June 2002, pp.1516- 1519.
- [14] B. Rajesh Kumar, Member, IEEE, K. Sridharan, Senior Member, IEEE, and K. Srinivasan, "The Design and Development of a Web-Based Data Acquisition System", *IEEE TRANSACTIONS ON INSTRUMENTATION AND MEASUREMENT*, VOL. 51, NO. 3, JUNE 2002.
- [15] O. Postolache, P. Silva Girb, H. Geirinhas Ramos, M. Dias Pereira, "A Distributed Virtual Instrument for Indoor Air Monitoring", *Proc. ICEMI'2001*, Guilin, China, November 2001.

## AUTHORS PROFILE

**Md. Fasiul Alam** was born in Chittagong, Bangladesh, in 1982. He received his Bachelor of Science in electrical and electronic engineering with first class first position from United International University, Bangladesh in 2009. He designed many electronic projects during his education period in his country and abroad. In 2010, he awarded full scholarship for Master of Science in electronic system engineering from Politecnico di Milano and now he is in final phase of his program. From 2009 to 2010 he was an electrical engineer at Bangladesh Shilpakala Academy. His research interests involves biomedical imaging, wireless security system for implantable devices etc.

**Helena Bulbul**, was born in Dhaka, Bangladesh, in 1967. She received her Bachelor of Science in electrical and electronic engineering and Master of Power engineering from Bangladesh University of Science and Technology (BUET), Bangladesh. She is now assistant professor at United International University (UIU), Bangladesh. Her research interest is Distributed Object Computing in Managing Large Scale Information System.

**Md. Delwar Hossain**, was born in Dhaka, Bangladesh, in 1983. He received his Bachelor of Science in electrical and electronic engineering from United International University Bangladesh in 2009. He is now Assistant communication and maintenance engineer at Boishaki International Television ltd. Dhaka, Bangladesh. His work of interest is wireless data communication and Information System.

# Internet Fraud as One of the Cyber Threat and its Impact in India

Author : Ashwini Manish Brahme<sup>1</sup> Assitant Professor,  
Indira Institute of Management(MCA), Pune,  
University of Pune, Maharashtra, India  
ashwini\_kulkarni21@rediffmail.com,  
[ashwiniak47@gmail.com](mailto:ashwiniak47@gmail.com)

## Abstract

India is becoming superpower in the IT field and also reached to the global world because of Internet but the fraud incidents are on the rise in almost every fast-growing industry across the country. The ratio of Internet fraud is growing significantly in India.

Life is about a mix of good and evil so is the Internet. For all the good it does us, cyberspace has its dark sides too. This paper discusses about the Internet Fraud and how the Internet fraud is creating the Cyber Cold War. It also briefs about the Internet Users in India, its Scope and the role of Internet for the Indian Business Growth. This paper talks about the Cyber crime and Cyber threat in India and the motives behind any Cyber attack or Internet Fraud, the tools used for the cyber terrorism, the Impact of Internet Threat at Work, proportion of Internet Fraud in India, and cyber crime cases with different examples. Furthermore paper gives details regarding how the Internet fraud is becoming a growing threat for the online retailers and business, how to deal with Internet Fraud to overcome the cyber threat and the role of Government of India, to avoid the misuse of Internet and the act or penalties for it and the skill to take out the Cyber Threat. This paper also gives the details on the Current status of cyber threat, internet fraud, and future in India with respect to the different security aspects and also talks about the Challenges that India need to face to beat the cyber threat.

**Keywords:** Cyber Crime, Cyber Cold war, Internet Fraud, Cyber Threat, IT

## I. INTRODUCTION TO INTERNET FRAUD AND CYBER COLD WAR

Internet plays vital role over the global world and the acceptance of Internet moves towards the boundary less trade medium in the era of globalization.

A majority of employees today spend a significant time on the Internet ; however mass of them are not aware of many things in Internet and hence not worried about the security threats arising from the Internet and because of this there are lot of chances of Internet Fraud and Cyber Threat which is becoming a part of "Cyber Cold War". Internet fraud is any type of fraud scheme that uses one or more.

components of the Internet - such as chat rooms, e-mail, message boards, or Web sites - to present fraudulent solicitations to prospective victims, to conduct fraudulent

transactions or to transmit the proceeds of fraud to financial institutions or to others those are becoming a part of this scheme. There are various types of Internet Fraud like Auction and Retail Schemes Online, Business Opportunity/"Work-at-Home" Schemes Online, Investment Schemes Online Credit-Card Schemes, Chatting, Make your online friend circle by using various sites, Mail spoofing etc.

## II. INTERNET USERS IN INDIA

Internet adoption continues to grow in India and the low cost of broadband has helped to increase Internet usage. Indians go online for a number of activities including e-mail and IM (98 percent); job search (51 percent); banking (32 percent); bill payment (18 percent); stock trading (15 percent); and matrimonial search (15 percent) etc.

The number of active Internet users in India had reached 32 million in September 2007, up only 10.9 million from 21.1 million in September 2006. Internet users (those who have used the Internet at least once in their lifetime) of 46 million in September 2007. [6]

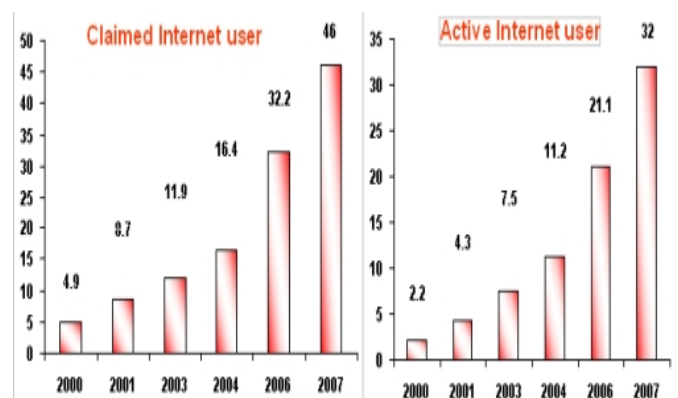

**Source:** Internet and Mobile Association of India (IAMAI) and IMRB International

This chart shows the growth of Claimed Internet users and Active Internet Users yearly. [3]

### III. SCOPE OF INTERNET IN INDIA

The low cost of the PC and the growing use of the Internet has shown the tremendous growth of business in India, in the recent years. According to the Indian Ecommerce Report released by Internet and Mobile Association of India (IAMAI) and IMRB International, “ The total online transactions in India was Rs. 7080 crores (approx \$1.75 billion) in the year 2006-2007 and expected to grow by 30% to touch 9210 crores (approx \$2.15 billion) by the year 2007-2008. [2]

Home Internet usage in India grew 19% from April 2006 to April 2007. In April 2007 it became 30.32 million and the eMarketer accept that there will be 71 million total Internet users in India by 2011. Rival tradeindia.com has 700,000 registered buyers and it has the growth rate of 35% every year which is likely to double in the year 2008. Indiamart.com claims revenues of Rs. 38 crores and has a growing rate of 50 every year. It receives around 500,000 enquiries per month. Undoubtedly, with the middle class of 288 million people, online shopping shows unlimited potential in India. The real estate costs are touching the sky. The travel portals' share in the online business contributed to 50% of Rs 4800 crore online market in 2007-08. The travel portal MakeMyTrip.com has attained Rs 1000 crores of turnovers which are around 20% of total e-commerce market in India. Further an annual growth of 65% has been anticipated annually in the travel portals alone. [3]

### IV. CYBER CRIME AND CYBER THREAT

Life is about a mix of good and evil. So is the Internet. For all the good it does us, cyberspace has its dark sides too. Unlike conventional communities though, there are no policemen patrolling the information superhighway, leaving it open to everything from Trojan horses and viruses to cyber stalking, trademark counterfeiting and cyber terrorism. Cyber crime is an unlawful act where in the computer is either a tool or a target which is used for creation of Cyber threat and Cyber terrorism as a premeditated use of disruptive activities or the threat in cyber space, with the intention to further social, ideological, religious, political or similar objectives, or to intimidate any person in furtherance of such objectives. The Cyber Criminals may be children and adolescents aged b/w 6-18 years, they may be organized hackers, may be professional hackers or crackers, discontented employees, cheaters or even psychic persons.

A full-fledged cyber attack on a nation may involve three steps. first, bring down the transportation and control systems. Second, bring down the financial systems (the stock markets and banks) and third, take control of the nations' utilities. A full-scale cyber attack can cause panic among people. It can trigger alarm systems in all major establishments, be it Parliament, Rashtrapati Bhavan, major hospitals, schools or colleges. A hack into the traffic light systems can cause havoc on roads in terms of accidents.

A break into the IT systems controlling the metro rail services can cause disasters. A break into your bank's system or tax department can fish out your pan number, your salary, the

investments you have made, the assets you possess to the cars you own.

A hack into your demat account can hurt you financially. One can know everything from details of your parents to the number of children you have. A hack into your personal computer can reveal all the searches you have made in the past to all the chat windows.

Imagine what chaos can prevail if the IT networks which control our power plants and nuclear plants fall into the hands of a rival nation. Imagine what can happen if one is able to break into the communication links of the defense ministry. It is very important to find out the reasons behind any attack .

#### **Motives behind any Attacks/ Internet Fraud:-**

1. Creating threat in public.
2. Create disobedience between different religious, racial, language, castes or communities.
3. Destructing the government established by law
4. Attitude of breaking the rules and integrity of the nation etc.

#### **Tools of Cyber Terrorism:-**

Cyber terrorists use various tools and methods to unleash their terrorism. Some of the major tools are as follows:

1. Hacking
2. Cryptography
3. Trojan Attacks
4. Computer worms
5. Computer viruses
6. Denial of service attacks
7. E-mail related crimes etc.

### V. IMPACT OF INTERNET THREAT AT WORK

Unsafe IT behavior leads to unintentional loss of confidential information. The survey was conducted by The Nielsen Company, India across five Indian metros from Manufacturing, IT, Pharmaceuticals, etc. - Mumbai, Delhi, Bangalore, Chennai and Hyderabad among Employees of large, medium and small organizations in India with Internet access to gauge the impact of Internet at work and the security risks it poses. 63 per cent of respondents from Delhi use their personal email ID for work purposes, against the average of 36 per cent. Delhi and Bangalore also have the highest proportion of respondents (32 per cent) who send work documents to personal e-mail accounts, versus the average of 23 per cent. In Bangalore, an average of 17 per cent of respondents admitted to clicking on links in e-mail sent from unknown sources and 22 per cent on pop-up ads highlighting a significant section of Internet users who are ignorant of online threats. 57 per cent employees feel leaking sensitive company information or infecting their company with malicious spyware or viruses (38 per cent) puts them at greater risk of losing their job, than not adhering to their organization's Internet policy (20 per cent).



### **Internet - A critical work enabler**

Normally all the Employees spend an average of 4.25 hrs per day on the Internet. Employees spend 45 per cent of their time (3.5 hours) per day surfing work-related websites, the highest being in Chennai 50 per cent (4.25 hours), and in Hyderabad 65 per cent (5.5 hours). The average time spent on non work-related websites is 5 hours per week. Enterprises incur a productivity loss of approximately Rs160, 000 per employee per annum due to non work-related surfing.

### **Data leakage**

35 per cent of employees feel most worried about losing both personal as well as work-related information. However, 28 per cent of employees do not feel worried at all about any personal or private information being stolen or accessed from their work PC.[5]

## **VI. INTERNET FRAUD AS THREAT FOR ONLINE RETAILERS**

Online retailers are increasingly becoming victims of repeated, opportunistic and unsophisticated fraud. Online retailers either do no checking or rely almost totally on manual fraud prevention measures. Almost half said they did not use any external data when verifying a customer's name and address, before authorizing an online transaction. 70% of companies interviewed thought that the internet was inherently more risky than other routes to market, with the majority of respondents experiencing an increase in fraud on the Internet over the last year. 52% of online traders claimed that Internet fraud was a problem for their organization and 55% said it was a growing problem.

### **Examples of Internet Fraud in India**

The major reason for the internet fraud in developing countries is due to the weakest security polices less technical infrastructure and no proper legislation.

The past 12 months have witnessed almost 400 registered attacks on Indian sites, owned by government departments or private institutions. That makes for more than one major government site being attacked on a daily basis. In the private sector, about 51% sites attacked belonged to the e-commerce sector, 47% belonged to the financial services sector.

#### **1) China mounts cyber attacks on Indian sites**

China has mounted almost daily attacks on Indian computer networks, both government and private, showing its intent and capability.

The core of the assault is that the Chinese are constantly scanning and mapping India's official networks. This gives them a very good idea of not only the content but also of how to disable the networks or distract them during a conflict.

#### **2) Phisherman nets Cash**

Rs. 2.7 lakh were siphoned off from an NRI's joint account with his wife in two separate incidents. In both incidents, transactions were made to the same persons ICICI bank account through e-banking.

### **3) Online advertise Clickers**

According to an article written by Times Of India, In India, A woman called Maya Sharma(not the real name),was actively participating in clicking online ads for some couple of hours daily to get paid for clicking the ads.

How this can be regarded as fraud because, generally the deal between the companies and the internet advertisers is, whenever the customers click the ads then, the companies tend to pay the money to the advertisers because of promoting their company for the customers. The pay rate normally varies from company to company and ad to ad, it was in the range of \$0.10 to \$0.25 depending upon the ad and company.

## **VII. HOW TO DEAL WITH INTERNET FRAUD AND CYBER THREAT**

Since the Internet is the medium for huge information and a large base of communications around the world, it is necessary to take certain precautions while operating it. Any person who operates the Internet should always abide by and following principles:

- 1.Should not disclose any personal information on internet and please keep your password and user id and access rights confidential.
2. Updated and latest anti-virus software should be used to protect the computer system against virus attacks.
3. While chatting on the net avoid sending photographs to anyone with personal data as it can be misused.
4. Backup of the data should always be kept to prevent loss from virus infectivity.
5. Children should be not permitted from accessing adult's sites by the parents to protect them from spoiling their mind and career.
6. A credit card number shall never be sent to an unsecured site.
7. Routers and firewalls can be used to protect the computer network.
9. The Cyber Cafes should be checked frequently and if any misuse is seen then report to the concerned authorities.
10. Make awareness of misuse of computers and access to unauthorized data and the penalties for it.
11. Don't reveal your credit card/ debit card PIN number.
12. Don't reveal your net banking and e-banking passwords.
13. Dont download files or software's without verifying its authenticity.
14. Avoid carrying of e-banking operations or any other important operations from cyber café and so on.

## **VIII. CURRENT STATUS OF INTERNET FRAUD IN INDIA**

An increase in the cyber crime is a nation wide phenomenon. The number of cyber crime incidents registered under the IT Act in the 35 mega cities in the country increased from 89 in 2006 to 118 in 2007 showing an increase of 32.6 per cent. Bangalore has registered the highest number of 40 cyber crime cases under IT act in 2007 followed by Pune with 14 cases, 10

crimes were reported in the Capital Delhi. This shows that 54.2 per cent cyber crime cases are reported only from the three cities Pune, Bangalore, Delhi out of India. Bhopal reported 158 cases under Indian Penal Code (IPC) Section. The Pune Police registered 21 cases during January to November 2008. Out of these maximum cyber crime cases are credit card fraud, phishing and e-banking fraud, email fraud and so on.

#### IX. INTERNET AND GOVERNMENT OF INDIA

India has done a good job by enacting a cyber law. It is the 12th country of the world having a cyber law. It covers areas like e-governance, e-commerce, cyber contraventions and cyber offences. The government of India is aware of the increasing misuse of the electronic media and online frauds. Therefore, the government of India has passed the Information and Technology Act to keep a track on Internet Fraud and cyber crime. The Act imposes heavy penalties and punishment on those who try to misuse this channel for personal benefit or to defraud others. The law has also established the authentication of the electronic records. Increase in the Cyber crimes in is causing cyber threat in India therefore the government has opened Cyber Crime Police Station. Online complaints can be filed for both cyber and Non Cyber crimes, through an online form which is available at <http://www.bcp.gov.in/english/complaints/newcomplaint.asp> to accept complaints filed with digital signatures. [8]

The Central Bureau of Investigation (C.B.I) in India set up a 'Cyber Crime Investigation Cell' and "Cyber Crime Research & Development Unit" (CCRDU) to collect and collate information on cyber crimes reported from different parts of the country.

#### X. FUTURE OF INDIA AND CHALLENGES TO FACE CYBER THREAT

Internet is the most powerful tool for the rapid development for their nation's economic and advanced developments so, depending on the internet the existing laws should be make very stronger law to punish these hackers, and the people who stole the credit cards numbers and personal information of other member's, who are creating threat, those who are spoiling or misusing the Internet and for the sake of the development of India we have to face and solve these cyber threat problems and to minimize the frauds by creating strong security application.

The draft amendments to IT Act 2000 do not have a single clause related to cyber terrorism or cyber war which compromises the national security, sovereignty and integrity of India. There is need of adequate talent to intercept the communication of terrorists via the internet. The Indian Army also has professionals working on information warfare but not many individuals are keen to join them as the salary levels are very low compared to what one gets in an IT company. The basic salary of an Indian Army or Navy officer ranges between Rs 8,500 per month to Rs 26,000 per month. On the other hand, the US Navy pays its Information warfare officers

salaries which start from \$2000 per month (Rs 80,000) and go up to \$6,300 (Rs 2.5 lakh) per month. Many private IT training institutes conduct courses in operating systems and ethical hacking; salaries for a fresh ethical hacker can start around Rs 4 lakh per annum. Experienced hackers just work from home and earn far higher salaries in private companies. Clearly there is a need to think of its compensation policy if it wants to attract good IT talent.

There should be some proactive protection for organizations and their customers from losses that can result from online fraud. The protection should be against the threats of identity theft, phishing, pharming, and other varieties of online fraud to preserve the organization's brand, improve customer loyalty, minimize losses, to control the cyber threat and fraud cases.

#### XI. CONCLUSION

Internet, being a global phenomenon is bound to attract many crimes. India has taken a key step in curbing Cyber Threat by IT ACT, CBI, Cyber Law, different Security techniques and by giving exclusive powers to the police and other authorities to tackle such crimes. As we know that Prevention is better than cure Cyber laws intended to prevent cyber threats and Internet Frauds.

In the cyber world Indian government has made arrangement to counter cyber warfare threat but it is only a one step ahead to face the cyber threat and cyber security cell. The conflict between the cybercrimer and the Internet users will be there as long as the internet is there; therefore there is need to take tremendous efforts to make the awareness of Internet Fraud and it is not easy to remove the fraud and threats 100% but we can motivate to control it, make awareness of Internet fraud and threats. As we know that nothing is impossible in the world, we can save India from Cyber cold War and Cyber Threat being an Indian and IT person.

#### REFERENCES

- [1] Outlook Business magazine (May 20, 2008)
- [2] [www.chillibreeze.com/articles\\_various/Ecommerce.asp](http://www.chillibreeze.com/articles_various/Ecommerce.asp)
- [3] [www.iamai.in](http://www.iamai.in) A Report by eTechnology Group@IMRB for Internet and Mobile Association In India
- [4] From Wikipedia, the free encyclopedia
- [5] Survey by the Nielsen Company, India
- [6] Internet Crime Complaint Center (IC3) Report
- [7] [www.mondaq.com](http://www.mondaq.com)

#### AUTHORS PROFILE

- Mrs. Ashwini Manish Brahme , working as Assitant Professor at Indira Institute of Managemnet (MCA), Pune , University of Pune .
- Published papers in national/Inetnational conference on cyber crime and cyber security.
- Currently working on research project sactioned by BCUd-University of Pune on Online voting using IRIS.

# APPLICATION OF POLYNOMIAL VECTOR (PV) PROCESSING TO IMPROVE THE ESTIMATION PERFORMANCE OF BIO DIESEL IN VARIABLE COMPRESSION RATIO DIESEL ENGINE

Suresh M.,  
Asst.Prof,Mechanical  
Engineering, Sri Sai Ram Engg.  
College,Chennai-  
44,Tamilnadu,India

Maheswar Dutta  
Professor and Principal, M.N.R  
Engg. College, Hyderabad, India

Purushothaman S  
Professor and Dean, Mechanical  
Engineering, Udaya School of  
Engineering, India-629204  
drspuru@gmail.com

**Abstract-**This paper presents the implementation of polynomial vector back propagation algorithm (PVBPA) for estimating the power, torque, specific fuel consumption and presence of carbon monoxide, hydrocarbons in the emission of a direct injection diesel engine. Experimental readings were obtained using the biodiesel prepared from the waste low quality cooking oil collected from the canteen of Sri Sairam Engineering College, India.. This waste cooking oil was due to the preparation of varieties of food (vegetables fried and non vegetarian). Over more than a week, trans esterification was done in chemical lab and the biodiesel was obtained. The biodiesel was mixed in proportions of 10%, 20 % , 30%,40%, 50% with remaining combinations of the diesel supplied by the Indian government. Variable compression ratio (VCR) diesel engine with single cylinder, four stroke diesel type was used. The outputs of the engine as power, torque and

specific fuel consumption were obtained from the computational facility attached to the engine. The data collected for different input conditions of the engine was further used to train (PVBPA). The trained PVBPA network was further used to predict the power, torque and brake specific fuel consumption (SFC) for different speed, biodiesel and diesel combinations and full load condition. The estimation performance of the PVBPA network is discussed.

**Keywords:** *polynomial vector, back propagation algorithm, waste cooking oil, biodiesel.*

## I INTRODUCTION

In this paper, performance of a diesel engine and exhaust emission content of the diesel engine when using Biodiesel blended with diesel has been analyzed. Data collected from the engine for various

loads / speed were used to train polynomial vector back propagation (PVBPA) neural networks.. Subsequently, the PVBPA was used to estimate the performance of the diesel engine and estimate the quality of the exhaust gas for different loads / speeds and combinations of fuel other than that used for training of the PVBPA.

Biodiesel refers to a vegetable oil or animal based diesel fuel consisting of long chain (methyl, propyl or ethyl) esters. Biodiesel [1-3] is typically made by chemically reacting lipids (eg. Vegetable oil, animal fat, tallow) with an alcohol producing fatty acid esters. The various Multipurpose oils [8,10-12] also used as biofuel such as Castor oil, Coconut oil (copra oil), Colza oil, Corn oil, Cottonseed oil, False flax oil, Hemp oil, Mustard oil, Palm oil, Peanut oil, Radish oil, Rapeseed oil, Ramtil oil, Rice bran oil, Safflower oil, Salicornia oil, Soybean oil, Sunflower oil, Tignut oil, Tung oil, are lists of vegetable oils that are suitable for biodiesel. Similarly, Inedible oils used only or primarily as biofuel such as Copaiba, Honge oil, Jatropha oil, Jojoba oil, Milk bush, Nahor oil, Paradise oil, Petroleum nut oil.

Vegetable oils are evaluated for use as a biofuel based on: a) Suitability as a fuel, based on flash point, energy content, viscosity, combustion products and other factors, b) Cost, based in part on yield, effort required to grow and harvest, and post-harvest processing cost.

Alternative fuels for diesel engines are becoming increasingly important due to diminishing petroleum reserves and the environmental consequences of exhaust gases from petroleum fuelled engines. A number of studies have shown that triglycerides hold promise as alternative diesel engine fuels. So, many countries are interested in that.

## II EXPERIMENTAL INVESTIGATION

The setup consists of single cylinder, four stroke, VCR (Variable Compression Ratio) Diesel engine connected to eddy current type dynamometer for loading. The compression ratio can be changed without stopping the engine and without altering the combustion chamber geometry by specially designed tilting cylinder block arrangement. Setup is provided with necessary instruments for combustion pressure measurements. The setup has stand-alone panel box consisting of air box, two fuel tanks for dual fuel test, manometer, fuel measuring unit, transmitters for air and fuel flow measurements, process indicator and engine indicator. Rotameters are provided for cooling water and calorimeter water flow measurement.

The setup enables study of VCR engine performance for brake power, indicated power, frictional power, brake mean effective pressure (BMEP), indicated mean effective pressure (IMEP), brake thermal efficiency, indicated thermal efficiency, Mechanical efficiency, volumetric efficiency, specific fuel consumption, A/F ratio and heat balance. Labview based Engine Performance Analysis software package "EnginesoftLV" is provided for on line performance evaluation.

1.Brake power (BP)=  $2 * \pi * n T / (60 * 1000)$

2.Brake specific fuel consumption (Kg/kwh)= Fuel flow in kg / hour / BP

3.Specific fuel consumption (SFC): Brake specific fuel consumption and indicated specific fuel consumption, abbreviated BSFC and ISFC, are the fuel consumptions on the basis of Brake power and Indicated power respectively.

### 2.1. Biodiesel preparation

In the present investigation, biodiesel was produced from waste cooking oil from the canteen of

Sri Sairam Engineering College, India. 2 gram Alkali catalyst and 35 cc methanol (as an alcohol) was applied for 150 gram waste cooking oil in this reaction. Biodiesel production reaction time was two hour with stirring and with moderate heat. Upto two weeks time is needed for separation. The waste cooking oil methyl ester was added to diesel fuel in 10 to 50 percent ratios and then used as fuel for one cylinder diesel engine.

## 2.2. Experimental set up and test procedure

The experimental setup consists of single cylinder diesel engine, an engine test bed and a gas analyzer. The engine setup is shown in Figure 1. The schematic of the experimental setup is shown in Figure 2.



Figure 1. Variable compression ratio diesel engine  
(Apex innovations)

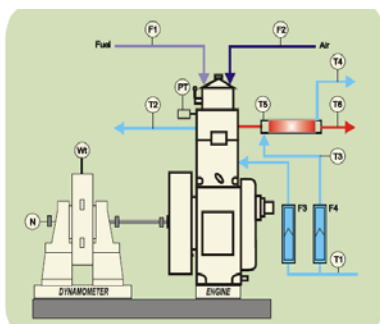

Figure 2. Schematic layout of the setup (Apex innovations)

where

F1 Fuel consumption kg/hr

F2 Air consumption kg/hr

F3,F4 Calorimeter water flow kg/hr

T3 Calorimeter water inlet temperature °K

T2,T4 Calorimeter water outlet temperature °K

T5 Exhaust gas to calorimeter inlet temp. °K

T6 Exhaust gas from calorimeter outlet temp. °K

There are two fuel tanks, one is for diesel fuel and the other for fuel blends. The engine under study is a VCR, water cooled single cylinder, in-line, naturally aspirated, Kirlosker diesel engine. The test engine was coupled to an electric eddy current dynamometer. A vehicle gas analyzer model was used for measuring CO and HC emissions. Engine was run at several speeds at full load and power, torque, fuel consumption and emissions was measured. Table 1 presents experimental data obtained. Table 2 presents the CO and HC emissions value obtained from exhaust gas analyzer.

TABLE I. 1 Experimental data obtained								
S.No.	Full load	Waste cooking oil (Biodiesel)	Diesel	Speed(rpm) of the engine	Power (KW)	Torque (N-M)	Specific fuel consumption (SFC) Litre/KW.	
1	1	0	1	1200	6.2	48	0.32	
2	1	0	1	1600	9.2	54	0.33	
3	1	0	1	2000	12.3	57	0.34	
4	1	0	1	2400	16.0	63	0.33	
5	1	0	1	2800	17.6	53	0.33	
6	1	0	1	3200	17.7	51	0.34	
7	1	10	90	1200	7.0	54	0.34	
8	1	10	90	1600	9.8	57	0.35	
9	1	10	90	2000	12.0	56	0.33	
10	1	10	90	2400	15.2	62	0.30	
11	1	10	90	2800	16.1	55	0.31	
12	1	10	90	3200	16.3	48	0.37	
13	1	20	80	1200	6.6	51	0.33	
14	1	20	80	1600	9.2	53	0.33	
15	1	20	80	2000	12.8	55	0.30	
16	1	20	80	2400	16.3	58	0.29	

17	1	20	80	2800	16.8	54	0.32
18	1	20	80	3200	18.0	52	0.33
19	1	30	70	1200	6.8	47	0.32
20	1	30	70	1600	9.6	51	0.31
21	1	30	70	2000	12.4	57	0.29
22	1	30	70	2400	15.0	64	0.34
23	1	30	70	2800	16.8	59	0.33
24	1	30	70	3200	17.4	48	0.36
25	1	40	60	1200	6.0	52	0.32
26	1	40	60	1600	9.6	56	0.31
27	1	40	60	2000	12.4	58	0.27
28	1	40	60	2400	15.0	59	0.31
29	1	40	60	2800	18.0	56	0.32
30	1	40	60	3200	17.0	53	0.34
31	1	50	50	1200	6.2	48	0.31
32	1	50	50	1600	9.0	53	0.32
33	1	50	50	2000	12.4	56	0.33
34	1	50	50	2400	15.8	59	0.32
35	1	50	50	2800	17.0	58	0.33
36	1	50	50	3200	16.8	50	0.36

Fuel blend	HC	C
B0	32	0.48
B10	18	0.49
B20	16	0.46
B30	5	0.45
B40	7	0.4
B50	7	0.38

### III POLYNOMIAL INTERPOLATION

The experimental data presented in Table 1 are further processed to make the data orthogonal to each other. The input vector is pre-processed and then presented to the network. The pre-processing generates a polynomial decision boundary. The pre-processing of the input vector is done as follows:

Let  $X$  present the normalized input vector,

where

$$X = \{X_i\}; i=1, \dots, nf,$$

$X_i$  is the feature of the input vector, and  $nf$  is the number of features ( $nf = 4$ )

An outer product matrix  $X_{op}$  of the original input vector is formed, and it is given by:

$$X_{op} = \begin{bmatrix} X1X1 & X1X2 & X1X3 & X1X4 \\ X2X1 & X2X2 & X2X3 & X2X4 \\ X3X1 & X3X2 & X3X3 & X3X4 \\ X4X1 & X4X2 & X4X3 & X4X4 \end{bmatrix}$$

Using the  $X_{op}$  matrix, the following polynomials are generated:

1) Product of inputs (NL1)

it is denoted by:

$\sum w_{ij}x_i$  ( $i \neq j$ ) = Off-diagonal elements of the outer product matrix.

The pre-processed input vector is a 6-dimensional vector.

2) Quadratic terms (NL2)

It is denoted by:

$\sum w_{ij}x_{i2}$  = Diagonal elements of the outer product matrix.

The pre-processed input vector is a 4-dimensional vector.

3) A combination of product of inputs and quadratic terms (NL3)

It is denoted by:

$\sum w_{ij}x_i$  ( $i \neq j$ ) +  $\sum w_{ij}x_{i2}$  = Diagonal elements and Off-diagonal elements of the outer product matrix.

The pre-processed input vector is a 10(6+4) dimensional vector.

4) Linear plus NL1 (NL4)

The pre-processed input vector is a 10-dimensional vector.

5) Linear plus NL2 (NL5)

The pre-processed input vector is a 8-dimensional vector.

6) Linear plus NL3 (NL6)

The pre-processed input vector is a 14-dimensional vector.

In the above polynomials such as NL4, NL5 and NL6

vector, the term 'linear' represents the normalized input pattern without pre-processing.

When the training of the network is done with a fixed pre-processing of the input vector, the number of iterations required is less than that required for the training of the network without pre-processing of the input vector to reach the desired MSE.

The combinations of different pre-processed methods with different synaptic weight update algorithms are shown in Table 3. As shown in Table 3, BPA weight update algorithms have been used with fixed pre-processed input vectors for learning.

BPA + NL1	BPA + NL2
BPA + NL3	BPA + NL4
BPA + NL5	BPA + NL6
NL is non-linear , 1-6 are the types	

#### IV BACK PROPAGATION ALGORITHM

A neural network is constructed by highly interconnected processing units (nodes or neurons) which perform simple mathematical operations, [5]. Neural networks are characterized by their topologies, weight vectors and activation function which are used in the hidden layers and output layer, [9]. The topology refers to the number of hidden layers and connection between nodes in the hidden layers. The activation functions that can be used are sigmoid, hyperbolic tangent and sine. The network models can be static or dynamic [7]. Static networks include single layer perceptrons and multilayer perceptrons. A perceptron or adaptive linear element (ADALINE), [4,6], refers to a computing unit. This forms the basic building block for neural networks. The input to a perceptron is the summation of input pattern vectors by weight vectors. In most of the

applications one hidden layer is sufficient. The activation function which is used to train the ANN, is the sigmoid function.

#### TRAINING STEPS INVOLVED.

##### *Forward propagation*

**Step 1:** The weights of the network are initialized.

**Step 2:** The inputs and outputs of a pattern are presented to the network.

**Step 3:** The output of each node in the successive layers is calculated.

$$O_{(\text{output of a node})} = 1/(1+\exp(-\sum w_{ij} x_i)) \quad (1)$$

**Step 4:** The error of a pattern is calculated

$$E(p) = (1/2) \sum (d(p) - o(p))^2 \quad (2)$$

##### *Reverse propagation*

**Step 1:** The error for the nodes in the output layer is calculated.

$$\delta_{(\text{output layer})} = o(1-o)(d-o) \quad (3)$$

**Step 2:** The weights between output layer and hidden layer are updated.

$$W(n+1) = W(n) + \eta \delta_{(\text{output layer})} O_{(\text{hidden layer})} \quad (4)$$

**Step 3:** The error for the nodes in the hidden layer is calculated

$$\delta_{(\text{hidden layer})} = o(1-o) \sum \delta_{(\text{output layer})} W_{(\text{updated weights between hidden and output layer})} \quad (5)$$

**Step 4:** The weights between hidden and input layer are updated.

$$W(n+1) = W(n) + \eta \delta_{(\text{hidden layer})} O_{(\text{input layer})} \quad (6)$$

Where

$o$  is the actual output of a node in hidden or output layer.

$\eta$  is the learning factor.

$\delta$  is the error of node.

$P$  is the pattern number.

$E$  is the errors of nodes in the output layer for a pattern.

The above steps complete one weight updation. Second pattern is presented and the above steps are followed for the second weight updation. When all the training patterns are presented, a cycle of iteration or epoch is completed. The errors of all the training patterns are calculated and displayed on the monitor as the mean squared error (MSE).

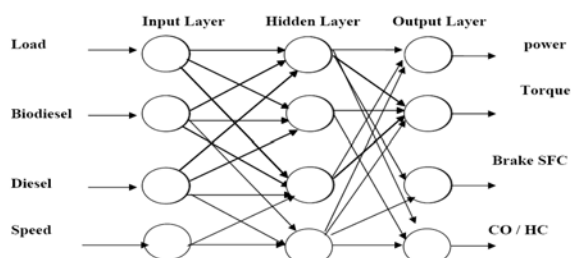

Figure 3. PVBPA network for predicting engine performance

## V. RESULTS AND DISCUSSION

### 4.1 Properties of waste cooking oil biodiesel fuels

Property	Biodiesel
Flash point, closed cup	182 °C
Pour point	-3°C
Kinematical viscosity, 40°C	4.15 mm <sup>2</sup> /s
Total Sulfur	0.0018 wt. %
Copper strip corrosion	1a
Cloud point	0 °C

### 4.2. Torque and Power

Fuel rack is placed in maximum fuel injection position for full load conditions. The engine is loaded slowly. The engine speed is reduced with increasing load. Range of speed was selected between 1200 – 3600 rpm. Engine test results with net diesel fuel showed that maximum torque was 64.2 Nm which occurred at 2400 rpm. The maximum power was 18.12 kW at 3200 rpm. Power and torque for fuel blends at full load is shown in Table 1. The

power estimation by different BPA with NL combinations are shown in Figures 4-9. The torque estimation by BPA with different NL are presented in Figures 10-15.

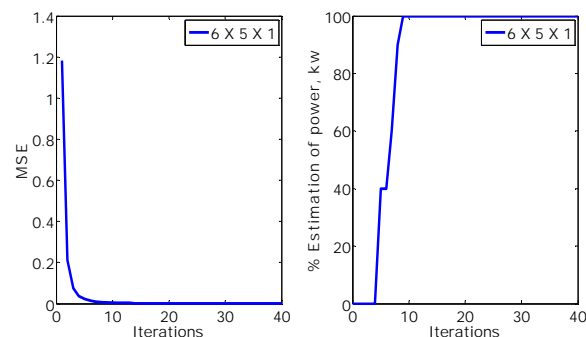

Figure 4. Estimation of power by BPA+ NL1

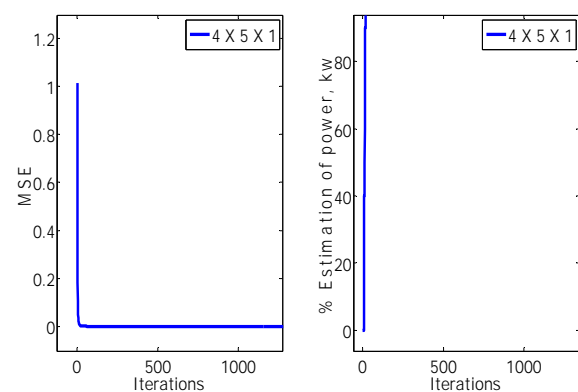

Figure 5. Estimation of power by BPA+ NL2

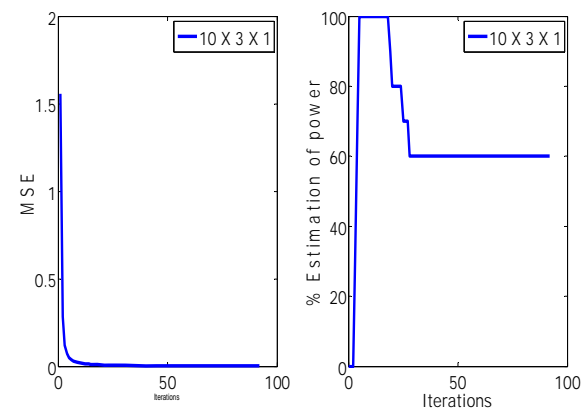

Figure 6. Estimation of power by BPA+ NL3



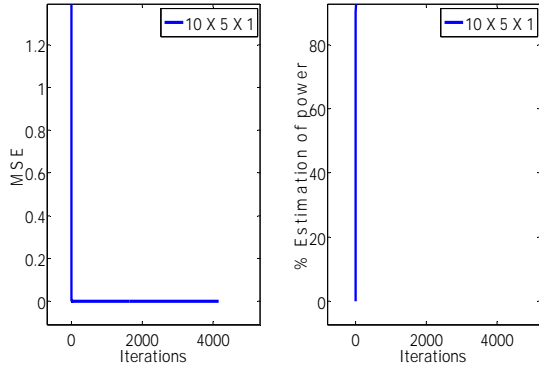

Figure 7. Estimation of power by BPA+ NL4

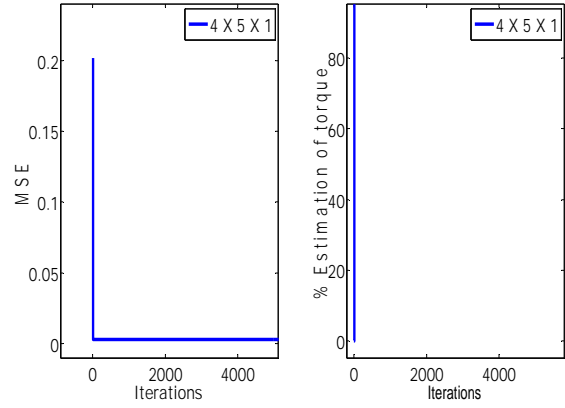

Figure 11. Estimation of torque by BPA+NL2

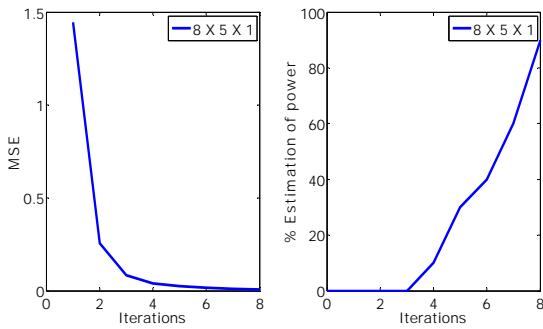

Figure 8. Estimation of power by BPA+ NL5

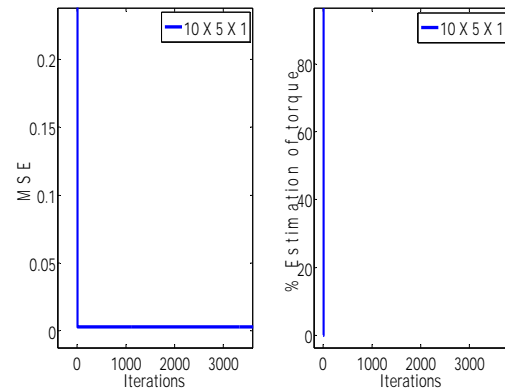

Figure 12. Estimation of torque by BPA+NL2

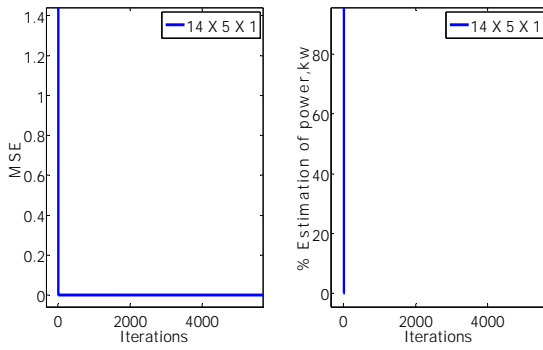

Figure 9. Estimation of power by BPA+ NL6

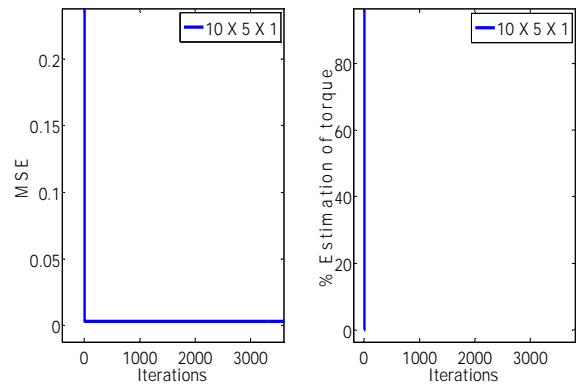

Figure 13. Estimation of torque by BPA+NL4

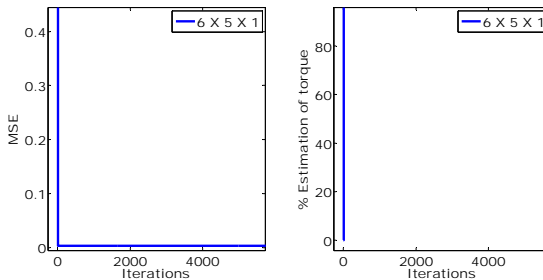

Figure 10. Estimation of torque by BPA+NL1

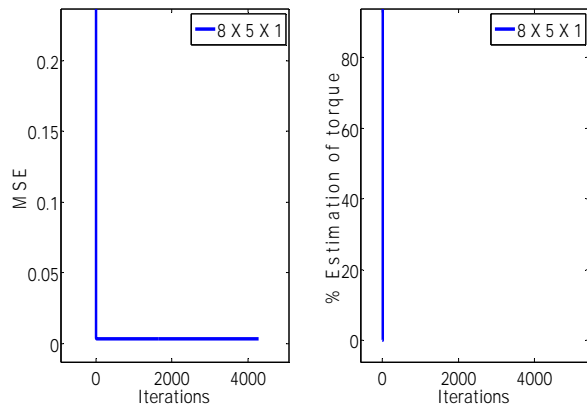

Figure 14. Estimation of torque by BPA+NL5

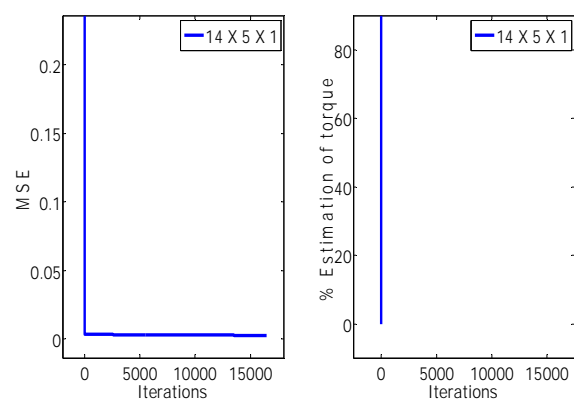

Figure 15. Estimation of torque by BPA+NL6

## VI. CONCLUSION

The engine has been tested under same operating conditions with diesel fuel and waste cooking biodiesel fuel blends. The results were found to be very comparable. The maximum power and torque produced using diesel fuel was 18.2 kW and 64.2 Nm at 3200 and 2400 rpm respectively. By adding 20% of waste cooking oil methyl ester, the maximum power and torque increased by 2.7% and 2.9% respectively. The concentration of the CO and HC emissions were significantly decreased when biodiesel was used (Table 2).

## REFERENCES

[1] Al-Widyan, M.I.; Al-Shyoukh, A.O., 2002, Experimental evaluation of the transesterification of

waste palm oil into biodiesel, *Bioresource Technology*, Vol. 85, Issue 3, pp. 253-256.

[2] Bento, F.M.; Camargo, F.A.O., Okeke, B.C., and Frankenberger, W.T., 2005, Comparative bioremediation of soils contaminated with diesel oil by natural attenuation, biostimulation and bioaugmentation, *Bioresource Technology*, Vol.96, Issue 9, pp.1049-1055.

[3] Karmee, S.K.; Chadha, A., 2005, Preparation of biodiesel from crude oil of *Pongamia pinnata* *Bioresource Technology*, Vol. 96, Issue 13, pp.1425-1429.

[4] Bernard Widrow, 1990, 30 Years of adaptive neural networks, Perceptron, madaline and back-propagation, *Proc. of the IEEE*, Vol.18, No. 9, pp. 1415–1442.

[5] Fortuna, L., Graziani, S., LoPresti, M., and Muscato. G., 1992, Improving back propagation learning using auxiliary neural networks, *Int. J of Cont.*, Vol. 55, No. 4, pp 793-807.

[6] Hirose, Y, Yamashita, K.Y. and Hijiya, S., 1991, Back-propagation algorithm which varies the number of hidden units, *Neural Networks*, 4, pp. 61-66.

[7] Hush, D.R., and Horne. B.G., 1993, Progress in supervised neural networks, *IEEE Signal Proc. Mag.*, pp. 8-38.

[8] Lang, X.; Dalai, A.K.; Bakhshi, N.N.; Reaney, M.J.; Hertz, P.B., 2001, Preparation and characterization of bio-diesels from various bio-oils, *Bioresource Technology*, Vol. 80, Issue 1, pp.53-62.

[9] Lippmann, R.P., 1987, An introduction to computing with neural nets, *IEEE Trans. On Acoustics, Speech and Signal Processing Magazine*, Vol. 35, No. 4, pp.4-22.

[10] Nouredini, H.; Gao, X.; Philkana, R.S, 2005, Immobilized *Pseudomonas cepacia* lipase for biodiesel fuel production from soybean oil, *Bioresource Technology*, Vol. 96, Issue 7, pp. 769-777.

[11] Palmarola-Adrados, B.; Choteborska, P.; Galbe, M.; Zacchi, G, 2005, Ethanol production from non-starch carbohydrates of wheat bran *Bioresource Technology*, Vol. 96, Issue 7, pp.843-850.

[12] Zullaikah, S.; Lai, C.C.; Vali, S.R.; Ju, Y.H., 2005, A two-step acid-catalyzed process for the production of biodiesel from rice bran oil *Bioresource Technology*, Vol. 96, Issue 17, pp.1889-1896.

# Computerized Analysis of Breast Thermograms for Early Diagnosis of Breast Cancer

Mrs. Asmita Wakankar<sup>1,2</sup>

<sup>1</sup>Research Scholar, Sathyabama University  
Chennai, India

<sup>2</sup>Asst Prof, Cummins College of Engg, Pune

[asmita\\_wakankar@yahoo.com](mailto:asmita_wakankar@yahoo.com)

Dr. G. R. Suresh

Professor, Eswari Engg College,  
Chennai, India

[grsuresh@rediffmail.com](mailto:grsuresh@rediffmail.com)

**Abstract—** Breast cancer is one of the leading causes of death in women. Early detection of breast cancer is the key to improve survival rate. Malignant tumors causes localized temperature increase on breast surface which shows as hot spot and vascular patterns in breast infrared thermograms. Thermographic detection of breast cancer primarily depends on the visual analysis of these patterns by physicians, which is hard to provide objective and quantitative analysis. This paper proposes computerized analysis of thermograms using a series of statistical features extracted from the thermograms quantifying the bilateral differences between left and right breast area for diagnosis of breast cancer. Thermography is particularly well suited for checking of tumors in their early stages or in dense tissue and implants.

**Keywords-** Breast Cancer –Infrared Thermal Imaging-Image Analysis

## I. INTRODUCTION

Breast cancer is the second leading cause of cancer related deaths of women in US. The incidence of breast cancer in India is also on rise. One out of 22 women in India is diagnosed with breast cancer. [14] Despite of considerable advances in treatment, the death rate because of breast cancer is high. Given these circumstances, early detection of breast cancer is considered as an important public health goal. Efficient and accurate evaluation can maximize cancer detection and minimize unnecessary testing and procedures. [1, 4]

Important risk factors for female breast cancer include an early age at the onset of menarche, late age of menopause, a first full-term pregnancy after the age of 30 years, a history of breast cancer in mother or sister. Obesity, nulliparity, and urban residence have also been associated with an increased risk of breast cancer. [12]

## II. TECHNIQUES USED FOR BREAST CANCER DETECTION

### A. Physical Examination:

When breast cancer has grown to the point where physical signs and symptoms appear, the patient feels a breast lump (usually painless). The physician visually inspects the breasts, noting asymmetry, nipple discharge, obvious masses, and skin changes, such as dimpling, inflammation, rashes, and unilateral nipple retraction or inversion. Benign masses generally cause no skin change and are smooth, soft to firm, and mobile, with well-defined margins. Malignant masses generally are hard, immobile, and fixed to surrounding skin and soft tissue, with poorly defined or irregular margins. Problem with Clinical examination is that it is insensitive and examiner dependent.

### B. Needle Biopsy:

Many suspicious breast abnormalities can be diagnosed without surgery by using needle biopsy. There are different types of needle biopsies:

#### *Fine Needle Aspiration (FNA)*

FNA biopsy uses a very thin, hollow needle to remove fluid and tiny fragments of tissue. This procedure involves inserting a thin needle into the breast to remove cells from a lump which are then examined under a microscope. Local anesthesia may be given. This test may be done to determine whether a lump is solid or is a fluid-filled cyst. A cyst will collapse and disappear after the fluid is removed. [12]

#### *Core Needle Biopsy (CNB)*

A core needle biopsy is a percutaneous procedure that involves removing small samples of breast tissue using a hollow 'core' needle. Core needle biopsy usually allows for a more accurate assessment of a breast mass than FNA because the larger core needle usually removes enough tissue for the pathologist to evaluate abnormal cells in relation to the surrounding small sample of breast tissue taken in the specimen. Nevertheless, core needle biopsy like FNA, only removes samples of a mass and not the entire

area of concern. Therefore, it is possible that a more serious diagnosis may be missed by limiting the sampling of a lesion. [12]

#### ***Stereotactic Vacuum Assisted Biopsy:***

The vacuum-assisted breast biopsy is a percutaneous procedure that relies on stereotactic mammography or ultrasound imaging. Stereotactic mammography involves using computers to pinpoint the exact location of a breast mass based on mammograms taken from two different angles. The computer coordinates will help the physician to guide the needle to the correct area in the breast. With ultrasound, the radiologist or surgeon will watch the needle on the ultrasound monitor to help guide it to the area of concern. Vacuum-assisted biopsy is a minimally invasive procedure that allows for the removal of multiple tissue samples. However, unlike core needle biopsy, which involves several separate needle insertions to acquire multiple samples, the special biopsy probe used during vacuum-assisted biopsy is inserted only once into the breast through a small skin nick made in the skin of the patient's breast. [12]

#### ***C. Mammography:***

Mammography is the primary imaging modality for breast cancer screening and diagnosis using x rays. Currently, it is considered as a most reliable and cost effective imaging modality and thus 'golden standard' for breast imaging. However, its false negative rate is higher. The danger of ionizing radiation results in increased cancer risk. It is also uncomfortable because the breast is compressed between two flat surfaces to improve image quality. It can't be used for dense breasts and for breast implants. [4]

#### ***D. Ultrasound:***

Ultrasonography is the most important adjunctive imaging modality for breast cancer diagnosis. Safety, ease of use and real-time imaging capability make breast ultrasound a method of choice for guiding breast biopsies and other interventional procedures. Breast ultrasound is routinely used for differentiating cysts and solid nodules with high specificity. In combination with mammography, ultrasound is used to characterize solid masses as benign or malignant. Ultrasound can be used in younger women and women with breast implants. But, the effectiveness depends on the ability of the radiologist performing the test. It has poor ability to visualize deep lesions and detect micro calcifications. [12]

#### ***E. Magnetic Resonance Imaging (MRI):***

Breast MRI offers valuable information about breast conditions that cannot be obtained by other imaging modalities, such as mammography or ultrasound. A benefit of MRI is that it can easily acquire direct views of the breast in any orientation while mammography requires re-

orientation of the breast and mammography system for each view desired. A few advantages of breast MRI are that it can be used in women with denser breasts, it is non-ionizing, it can take images in any orientation, it can determine multifocal cancers and is useful in determining if the cancer has spread to the chest wall. It can also be used to check for recurrence of cancer in women who have undergone lumpectomy. The disadvantages are that it is expensive, requires injection of a contrast agent for functional imaging and long scan times in comparison to x-ray mammography. Specificity can be limited, it is highly sensitive to small abnormalities, and cannot image calcifications and can induce feelings of claustrophobia. [4]

#### ***F. Positron Emission Tomography (PET):***

Positron emission tomography is one of the newest forms of imaging tests. A tiny amount of radioactive substance is injected into an arm vein. This substance gives off small amount of radiation that is detected by a special PET scanner to form an image. A PET scan may be combined with computed tomography (CT) to provide both an anatomical and functional view of the suspect cells. With all this information, doctors can better differentiate between healthy and cancerous cells, even when the cancer is too small to detect by conventional imaging. PET is being successfully used to detect metastatic disease. But it is expensive and scarce. [7, 12]

#### ***G. Electrical Impedance Tomography (EIT):***

EIT is an imaging method that utilizes an array of electrodes to apply currents to an imaging domain and measures the resulting voltages on the periphery. EIT scans the breast for electrical conductivity based on the idea that breast cancer cells conduct electricity better. The test does not use radiation and does not require breast compression. It is a noninvasive low cost technique but has low S/N ratio and low resolution. It requires localization of lesion before hand, insensitive and observer dependent. [12]

All above methods are often too cumbersome, costly, inaccessible or invasive to be used as first line detection modalities alongside clinical examination and mammography. [7] Thus, thermogram appears as one of the most promising and suitable alternatives for preliminary screening.

#### ***H. Thermography:***

Infrared thermography is a powerful detector of problems that affect human physiology. It uses an infrared camera to detect the natural thermal radiation emitted from human body and obtains an image recording the surface temperature distribution of the body. Thermography is a noninvasive, painless, low cost technique, requires no contact nor compression, no radiation or access and thus risk free for patients. [22] It is able to warn women up to 10 years before a cancer is found. It is the only method that

mediates significant information on breast physiology. [7] Thus, thermogram plays a vital role in breast cancer, be it risk assessment, detection, diagnosis or prognosis. It is a proper choice for annual routine medical check up of breast cancer. [8] Despite of strengths reported, thermogram is associated with some of the limitations such as environment dependent, operator dependent, not descriptive, difficult to interpret, nonspecific, inconsistent and no standard analysis procedure.

Table 1 summarizes the available modalities for breast cancer detection and the reported accuracy respectively. The accuracy is only an estimate because these modalities perform differently on different types of breast cancer, on different age group and apart from that most of the tests are done on small populations. [7]

Table 1: Comparison of Different Breast Imaging Modalities [7]

Method	Sensitivity (%)	Specificity (%)
Clinical Exam	48.3-59.8	90.2-96.9
FNA Biopsy	85-88	55.6-90.5
CN Biopsy	91-99	73-100
Vaccum Assisted Biopsy	95	98
Digital Mammography	64.3	88.2
Sonography	13-98.4	67.8-94
MRI	86-100	21-97
PET	96	100
EIT	62-93	52-69
Thermography	90	90

### 1. Principal of Thermography:

Thermography is based on the principle that metabolism and blood vessel proliferation in both pre-cancerous tissue and the area surrounding a developing breast cancer is almost always higher than in normal breast tissue. Developing tumors increase circulation to their cells by enlarging existing blood vessels and creating new ones in a process called vascularisation. This process frequently results in an increase in regional surface temperatures of the breast. Thermography uses ultra-sensitive infrared cameras and PCs to generate high-resolution diagnostic images of these temperature variations. [12]

### 2. Infrared Camera Developments:

Early infrared cameras were bulky and inconvenient to use. They required liquid nitrogen for cooling. Modern cameras are compact, portable, and can be used in any orientation. They have high spatial and temperature resolutions. [22]

### 3. Infrared Thermography of Normal Healthy Subject:

Temperature is a long established indicator of health. Infrared thermal imaging has been used for several decades to monitor the temperature distribution of human skin. Abnormalities such as malignancies, inflammation and infection cause localized temperature increase which show as hot spot or as an asymmetrical patterns in an infrared thermogram. In a healthy subject, there is a contra lateral symmetry in skin temperature distribution and an asymmetry above a certain level is a strong indicator of abnormality. [22]

Table 2 gives contralateral skin temperature differences in normal subjects. It is observed that highest skin temperature on body is forehead and lowest was on toes.

Table 2: Contralateral Temperature Differences in Normal Subjects [22]

Body Segment	Cutaneous Sensory Nerves & Segments	Mean $\Delta T$ (K)	SD $\Delta T$ (K)
Forehead	Trigeminal nerve (v1)	0.12	0.093
Cheek	Trigeminal nerve (v2)	0.18	0.186
Chest	Intercostal (T1-T7)	0.14	0.151
Abdomen	Intercostal (T7-T10)	0.18	0.131
Neck	Cervical (C2-C5)	0.15	0.091
Arm(Biceps)	Med Antebrachial (C8,T1)	0.13	0.119
Thigh(Anterior)	Ant. Fem. Cutaneous	0.11	0.085
Forearm(Medial)	Med. Antebrachial(C8,T1)	0.32	0.158
Heel	Tibial (S1-2)	0.20	0.220
Average Finger Tips	Median & Ulnar	0.38	0.064

## III. METHODS

### A. Data Acquisition:

#### ➤ Procedure:

In order to get the best possible examination, free of artifact, the following instructions are STRONGLY recommended.

- No prolonged sun exposure (especially sunburn) to the breasts 5 days prior to exam.
- No use of lotions, creams, powders, or makeup on the breasts on the day of the exam.
- No exercise 4 hours prior to exam.
- No tobacco use, caffeinated soda, coffee, or tea 2 hours prior to exam.

The imaging room must be temperature and humidity-controlled and maintained between 18 and 23°C, and kept to

within 1°C of change during the examination. The room should also be free from drafts and infrared sources of heat i.e. sunlight and incandescent lighting. It must be ensured that the patients are within the period of the 5<sup>th</sup>-12<sup>th</sup> and 21<sup>st</sup> day after the onset of menstrual cycle as the women body temperature is known to be stable in this period. As with mammography, a minimum series of images is needed in order to facilitate adequate coverage. The series includes the bilateral frontal breast along with the right and left oblique views. The bilateral frontal view acts as a scout image to give a baseline impression of both breasts. The oblique views (approximately 45° to the detector) expose the lateral and medial quadrants of the breasts for analysis. [9]

➤ *System Setup:*

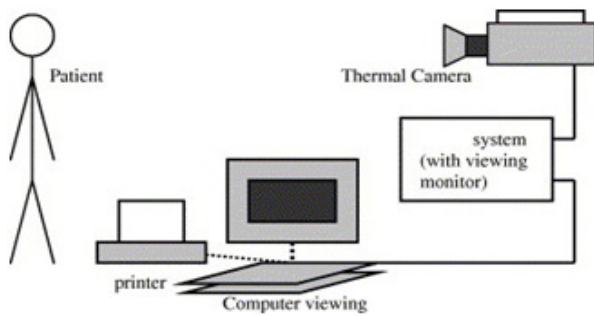

Figure 1: Basic Set Up of the System [7]

Figure 1 show the system set up. Thermography measures the temperature of the surface of our bodies. In breast thermography, the temperature of every spot on the breasts is measured and the data is sent to a computer. The computer translates and transforms this data into temperature patterns as shown in the images.

➤ *Sample Thermograms:*

A breast infrared thermogram is shown in Figure 2. All the image outputs are standardized at a temperature range of 32°C to 38°C with rainbow colour palette. With this setting, what appears white represents the highest temperature, followed by red, yellow, green, cyan, blue, and with black as the coolest. It is worth noting that there are various colour palettes to choose from. Thus, the same picture with the same temperature information can be presented in varying colour schemes.

Figure 2 shows the sample thermograms. Figure 2(a) is a thermogram for 45 year old healthy woman, where good symmetrical color pattern without any prominent hot spot can be seen. Figure 2(b) is a thermogram of 55 year old patient with suspected cancer on left side. Asymmetrical color pattern with increased breast temperature can be seen here. The left breast seems hotter than the right with two prominent hot spots.

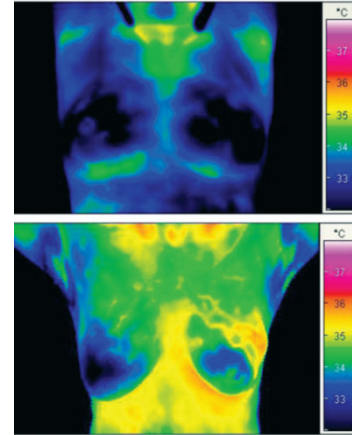

Figure 2(a): Healthy Subject - Symmetrical temperature  
(b): Cancerous Patient - Abnormal Thermogram

#### IV. IMAGE ANALYSIS

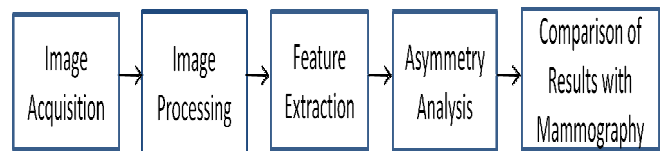

Figure 3: Block Diagram of System

Figure 3 shows the block diagram of the system. Image Segmentation and Asymmetry analysis are proposed as an efficient method for breast infrared thermograms in most of the earlier studies. The following section gives the review of various papers.

Jonathan Head et al, 1997 divided each breast into upper outer, upper inner, lower outer and lower inner quadrants by drawing lines on thermograms from the chin of patient to each nipple and then two horizontal lines left and right to the edge of breast and finally a forth line to the lowest contour of the breast. The statistical features like mean, standard deviation, median and maximum temperature is determined for each quadrant of both breasts and comparative statistics is generated for right and left breast.

Hairong Qi et al, 2000 proposed automatic segmentation and automated asymmetry analysis of thermograms for abnormality detection. The steps involved were finding edge image by Canny detector, feature Curve detection by Hough Transform, segmentation based on feature curves, Bezier transform derived from segments and curvature curve computed from histograms. Edge image was derived using inbuilt Canny Edge detector in MATLAB because of its robustness to noise. Hough transform is used to detect the parabolic breast boundaries. Segmentation was based on three key points, the two armpits and the

intersection of two parabolic curves derived from lower boundaries of breast. Histogram giving the brightness distribution was calculated using Bezier splines.

J. Koay, 2004 et al used automated technique for segmentation which assumed an elliptic shape of breast boundaries. Hypothesizing that the centre of mass of all the edges was likely to be located within the breast area, edges closer to the centre of mass were considered to be part of breast. An inclusion factor to determine the cutoff distance from centre of mass is derived. The smallest convex region enclosing the remaining edges was sought and ellipse best fitting its contour was chosen as breast area.

N. Scales et al, 2004 implemented edge detection by Canny's method. This method implements the first derivative of a Gaussian function to smooth the image and to obtain the magnitude and orientation of the gradient for each pixel. It is found that most images require different low/high threshold values in order to eliminate all but the strongest edges in the image without removing the bottom breast boundary. They have suggested use of adaptive filter to find threshold values for each image. The method to detect lower boundaries uses the fact that lines normal to the tangent of a circle at any point will cross through the circle centre. The most frequent intersection of the normals in the image determined the most likely candidate for circle centre. The image is divided in two small images and then Hough transform is applied. But HT proved to be too sensitive to small changes in curvature and thus many false edges are detected. Also it was unable to detect flat lower boundaries. So a simple strategy of connected edge algorithm is used. A recursive search algorithm is used to locate the pixels that are connected to their neighbours by a distance of no more than 2 pixels. The largest connected object in each half of the image is considered as lower boundary.

Hosseini Zadeh et al, 2011 used half circular and half parabola technique to detach breast region from the image. To delete the circles appearing outside the body, the edges are removed by applying SOBEL algorithm. Then using half parabola technique lower breast boundaries are found out. After segmentation, fuzzy K means clustering is used which compares the colors in relative sense and groups them in clusters. The red color represents the suspicious region for cancer.

In all above studies, feature extraction was done for asymmetry analysis of contralateral breasts. For each patient the mean, standard deviation, minimum, median and maximum temperature is calculated and comparison between two breasts is made. Histograms of left and right breast are plotted on the graphs. Then 'moments' are used through which valuable statistical information is presented. It includes mean, variance, skewness and kurtosis.

S. Umadevi et al, 2010 suggested use of two stages for thermogram analysis. First stage identifies the body boundary and second stage extracts highest temperature area of thermogram. Finally by combining output of two stages a single image is created which is easy to interpret. The pixels

of the thermogram are divided in two groups-first group of pixels belong to ambient temperature values and second group of pixels belong to surface body temperature values. Divided pixel values are then passed to edge detector algorithm to identify body boundary. From two dimensional matrix of temperature values representing the breast thermal image, maximum temperature value is selected. Further pixels of image are grouped into two. The first group of pixels is having temperature value less than maximum temperature and second group pixels having temperature values greater than or equal to maximum temperature values.

Xianwu Tang et al, 2008 have suggested use of localized temperature increase (LTI) as prominent feature of carcinomatous possibility. In this, the background temperature distribution of the LTI region is found out. Then the temperature increase value of each pixel can be calculated as its temperature minus the corresponding background temperature. The maximum of temperature increase values of all the pixels is defined as the LTI amplitude.

## V. CONCLUSION

In conclusion, Thermography is an effective noninvasive diagnostic tool for early breast cancer detection. With the improved infrared camera developments and computer aided approach for automated image analysis, the technique would be of great practical use in diagnosing breast cancer in early stages. Use of Canny edge detector and Hough transform proves best for extracting breast region out of thermal image. Based on statistical parameters, pixel distribution asymmetries can be identified for both breasts. The color analysis of thermograms using K mean and C means clustering will be a supporting method to extract the cancerous region. For accurate results the calibration of camera is very important. The method can be a powerful adjunct tool together with mammography for diagnosis of breast cancer.

## ACKNOWLEDGMENT

The authors are grateful to Dr. Madhuri Khambete and Prof A. D. Gaikwad for their motivation, and help towards the completion of this paper. We would also like to thank our colleagues from Instrumentation and Control Dept. of Cummins College of Engineering for Women for their feedback during the discussions.

## REFERENCES

- [1] E.Y.K. Ng , U. Rajendra Acharya , Louis G. Keith , Susan Lockwood, 'Detection and Differentiation of Breast Cancer Using Neural Classifiers With First

- Warning Thermal Sensors', Information Sciences 177, 2007, 4526–4538
- [2] Gerald Schaefer, Michale Zavisek, Tomoharu Nakashima, 'Thermography based Breast Cancer Analysis Using Statistical Features and Fuzzy Classification', Pattern Recognition 47, 2009, 1133-1137
- [3] E.Y.-K. Ng,'A Review of Thermography as A Promising Non Invasive Detection Modality for Breast Tumor', International Journal of Thermal Sciences 48, 2009, 849–859
- [4] Ming-Yih Lee, Chi-Shih Yang, 'Entropy Based Feature Extraction and Decision Tree Induction for Breast Cancer Diagnosis with Standardized Thermograph Images', Computer Methods and Programs in Biomedicine 100, 2010, 269–282
- [5] Paulo J. Lisboa a, Azzam F.G. Taktak, 'The Use of Artificial Neural Networks in Decision Support in Cancer: A Systematic Review', Neural Networks 19, 2006, 408–415
- [6] J.P. Agnelli, A.A. Barrea, C.V. Turner,'Tumor Location and Parameter Estimation by Thermography', Mathematical and Computer Modelling 53, 2011, 1527–1534
- [7] T.Z. Tan , C. Quek , G.S. Ng , E.Y.K. Ng,'A Novel Cognitive Interpretation of Breast Cancer Thermography with Complementary Learning Fuzzy Neural Memory Structure', Expert Systems with Applications 33, 2007, 652–666
- [8] Xianwu Tang , Haishu Ding , Yun-e Yuan , Qing Wang,'Morphological Measurement of Localized Temperature Increase Amplitudes in Breast Infrared Thermograms and its Clinical Application ', Biomedical Signal Processing and Control 3, 2008, 312–318
- [9] Joseph D. Bronzino, 'Medical Devices and Systems-Biomedical Engineering Handbook',Edition 3,Chapter 25
- [10] H.Ghayoumi Zadeh, I.Abaspur Kazerouni, J.Haddadnia,'Distinguish Breast Cancer Based on thermal features in Infrared Images', Canadian Journal on Image Processing and Computer Vision Vol. 2 No. 6, July 2011
- [11] Nimmi Arora, Diana Martins, Alexander Micahale Osborne, 'Effectiveness of a Noninvasive Digital Infrared Thermal Imaging System in the Detection of Breast Cancer', American Journal of Surgery, 2008, 196, 521-526
- [12] Sachin Prasad, Dana Houserkova,'The Role of Various modalities in Breast Imaging', *Biomed Pap Med Fac Univ Palacky Olomouc Czech Repub.* 2007, 151(2):209–218
- [13] Hairong Qi, Phani Teja Kuruganti, Wesley E. Snyder 'Detecting Breast Cancer from Thermal Infrared Images by Asymmetry Analysis',
- [14] Hossein Ghayoumi Zadeh, Iman Abaspur Kazerouni, Javad Haddadni, 'Diagnosis of Breast Cancer and Clustering Technique Using Thermal Indicators Exposed by Infrared images', Journal of American Science, 2011;7(9);
- [15] Pragati Kapoor, Ekta Bhayana, Dr. S. V. A. V Prasad,'Real Time Intelligent Thermal Analysis Approach for Early diagnosis of Breast Cancer', International Journal of Computer Applications, 2010,(0975 – 8887) Volume 1 – No. 5
- [16] Jonathan Head, Charles A. Lipari, Fen Wang and Robert Elliot,'Image Analysis of Digitized Infrared Images of The Breasts from A First Generation Infrared Imaging System', 19<sup>th</sup> International Conference Proceedings, 1997, Chicago
- [17] Hairong Qi, Wesley E. Snyder, Jonathan Head and Robert Elliot 'Detecting Breast Cancer from Infrared Images by Asymmetry Analysis', 22<sup>nd</sup> Annual EMBS Conference, 2000, Chicago
- [18] N.Scales, C.Herry, M.Frize, 'Automated Image Segmentation for Breast Analysis Using Infrared Images', 26<sup>th</sup> Annual International EMBS Conference, September 2004, Sanfrancisco
- [19] N.Scales, C.Herry, M.Frize, 'Processing Thermal Images to Detect Breast Cancer and Assess Pain', 4<sup>th</sup> IEEE Conference on Information Technology Applications in Biomedicine, UK
- [20] J.Koray, C.Herry, M. Frize,'Analysis of Breast Thermography with an Artificial Neural Network', 26<sup>th</sup> Annual International EMBS Conference, September 2004, Sanfrancisco
- [21] E.Y.K. Ng , E. C. Kee, U. Rajendra Acharya, 'Advanced Technique in Breast Thermography Analysis', 27<sup>th</sup> Annual EMBS Conference Proceedings, September 2005, Shanghai, China
- [22] Bryan F. Jones, 'A Reappraisal of the Use of Infrared Thermal Image Analysis in Medicine', IEEE Transactions on Medical Imaging, Vol 17, No 6, december 1998
- [23] Yune Yuan, Quing Wang, Yan Tan, Li Rong, Li Ji Ye, 'Analysis of Breast Diseases Examination with Thermal Texture Mapping, Mammography and Ultrasound', 26<sup>th</sup> Annual International EMBS Conference, September 2004, Sanfrancisco





**Asmita Wakankar** received the B.E. and M.E. degree in Biomedical Instrumentation from University of Pune. She is currently working towards the Ph.D. degree at Sathyabama University, Chennai. She is currently working as an Assistant Professor at

MKSSS's Cummins College of Engineering for Women, Pune, INDIA.



**Dr. G. R. Suresh** received the B.E. in Electronics and Telecommunication from Manonmanium Sundaranar University, Tirunelveli. M.E. degree in Communication Systems from Madurai Kamaraj University, Madurai. And Ph.D. degree from Anna University, Chennai, INDIA. He is currently working

As a Professor at Department of ECE, Easwari Engineering College, Ramapuram, Chennai, INDIA.

# INFORMATION SECURITY ON THE COMMUNICATION NETWORK IN NIGERIA BASED ON DIGITAL SIGNATURE

*O. S. Adebayo (MCPN), V. O. Waziri (PhD) and J.A  
Ojeniyi (MNCS)*

Cyber Security Science department, Federal University of  
Technology Minna, Nigeria  
waleadebayo@futminna.edu.ng, onomzavictor@gmail.com,  
ojeniyijoseph@yahoo.co.uk

*S. A. Bashir (MNCS)*

Computer Science department, Federal University of  
Technology Minna, Nigeria  
basirsulaiman@futminna.edu.ng  
Amit Mishra  
Mathematics and Computer Science department, IBB  
University, Lapai, Nigeria  
i.amitmishra@gmail.com

**Abstract - This paper presents simple abstraction concepts for some digital signature scheme algorithms that include ElGamal Signature scheme, Schnorr Signature scheme, Elliptic Curve Signature (ECS), and Digital Signature Standard (DSA). It also examines the security of this digital signature scheme to measure its effectiveness and improve on the variability. The algorithms are essential in securing application in dispatching the documents on the communication network. We try to explain the algorithms in simple form and the examples are experimented in C++ programming language which presupposing little or easy mathematical background comprehension and easy computations.**

**Keywords - ElGamal Signature scheme, Signature Scheme, Elliptic Curve Signature, Information Security, Digital Signature**

## I. INTRODUCTION

Information security has become a serious concern in disseminating secured data over the Internet. One of the great advantages of Internet is the transmission of message and data on the Internet. However, these pretty pieces of data and some worthy information can be intercepted by the enemies, read and modified which invalidate the originality and authenticity of the document. A document sending to a particular destination can also be forged in one way or the other, which could undermine the essence of the message. Digital signature has therefore, become a necessary tool to sign an on line's messages electronically and authenticate the originality of its document in order to identify the identity of the sender and check the activities of hackers. A signature (binary construed) is used in everyday situations such as writing a letter, withdrawing money from a bank, signing a contract, etc.

Digital signature is a signature scheme of signing a message stored in electronic form [1] as against the "Conventional" handwritten signature attached to a paper

document used to specify a person responsible for the signature. A signed message over the Internet can be transmitted over a computer and other communication network systems. In signing an electronic message, an algorithm that is used to sign the message must "bind" the signature to the message as against the conventional signature, where a signature is part of physical data or Information.

The problem of signing an online message is in two categories. The first problem is the problem of signing a document while the second problem is that of verification. A conventional signature could be easily verified by simply compared with the original or authentic signature. For example, a customer paycheck could be verified by a cashier by comparing the signature on the check with the original one in the bank for verification. Digital signature, on the other hand requires publicly known verification algorithm, thus a digital signature can be verified by anybody and therefore, a need to use a secure signature scheme in order to prevent the possibility of forgeries and abdication by intruders.

The major challenge associated with digital signature is its feature of reused. A copy of digital message is identical to the original and can be easily reused by anybody. For example, if Ade authorizing Ola to withdraw certain amount of money from his account, in order to prevent Ade from withdrawing the amount several time, the digital message should contain certain information, such as date in order to prevent it from being reused.

Digital signature scheme has two important components; namely, Signing and Verification algorithms. Message  $x$  that is signed by Ade using a signature algorithm  $Sig_k$ , which depends on his private key can be verified by

Corresponding Author: **Olawale Surajudeen Adebayo (MCPN, MNCS)**

Ola using a publicly known verification algorithm  $Ver_k$ . Consider a pair  $(x, y)$  where  $x$  is a message and  $y$  indicate a signature on a message  $x$ , then the resulting verification algorithm  $Ver_k x = y$  is true if a message  $x$  has been validly signed and  $y = Ver_k x$ ;  $x$  is false if  $x$  is a forged signature or not previously signed.

This paper examines various signature schemes algorithms that are being used on the insecure Internet to sign a message electronically (that is, signing and verification algorithm). The security requirements of the scheme are also highlighted. The rest of the paper is as follows: In section 2 deals with related literatures review, section 3 emphasizes on the methods for the sampled modern public key infrastructure (PKI); while section 4 deals with experimental performance of the stipulated algorithms in section 4, and finally in section 5, we present some fundamental suggestions for future research works.

## II. RELATED WORK

The notion of digital signature exists as a result of quest to reduce or eradicate the spate digital data forgery on the insecure communication network. To this end, [5] developed an algorithm known as ElGamal signature scheme, which is non-deterministic. This implies that for any given message  $x$ , there exist many valid signatures  $Y$  as a vector and a message can be signed with varied private keys while the verification can be done using the public key algorithm. This algorithmic process is known as the public Key cryptographic infrastructure.

The National Institute of Standard and Technology (NIST), [7] would later modified the ElGamal signature scheme and produced another algorithm known as Digital signature scheme, Today, the vulnerability of the communication network is pervasive and required high security attentions, which necessitates the use of a large modulus  $p$  (a prime number that is one of the public keys used to verify signed message). This was brought about the development of variants of ElGamal signature scheme. All the variants adopted the use of 2048 bits, which is effective for powerful application like smart card and biometric machine as against the 1024 bit modulus  $p$  used in ElGamal signature. [4] proposed another variant of ElGamal signature scheme, which reduces greatly the size of the signature.

[2] proposed Digital Signature Algorithm (DSA), which is another modification of the ElGamal signature scheme, adopts some ideas used in Schnorr signature scheme in order to increase the security of the signature. In order to present to a layman in a simplest form the idea of encryption and decryption [6] illustrated how cryptography could be used to enhance security on the internet. On the other hand, the idea of decrypting ciphertext without the knowledge of encryption was presented by [3] where they presented differential cryptanalysis of DES like cryptosystem.

## III. METHODOLOGY

In this section, we present the useful sampled algorithm in these sequential orders: The two important components of Signature Scheme as mentioned earlier are signing algorithm and verification algorithm. An online message  $x$  that is signed by Ade using a signing algorithm, with his private key can be in order way round verified by Ola with a verification algorithm using a public key.

The Signature Scheme that is being used on the Internet as a product of cryptosystem, with its signing and verification algorithm in order to secure and protect information from sender to a destination is given by the generic definition:

A Signature Scheme is a five-tuple  $(P, A, K, S, V)$ , where each notation is given below.

$P$ : is a finite set of possible messages

$A$ : is a finite set of signatures

$K$ : the keyspace is a finite set of possible keys

For each  $k \in K$ , there is signing algorithm  $Sig_k \in S$ , and a corresponding verification algorithm  $Ver_k \in V$ . Each  $Sig_k: P \rightarrow A$ , and  $Ver_k: P \times A \rightarrow \{true, false\}$  are functions such that the following verification algorithm are satisfied for message  $x \in P$  and signature  $y \in A$  on the message

$$Ver(x, y) = \begin{cases} true & \text{if } y = Sig_k \\ false & \text{if } y \neq Sig_k \end{cases}$$

Where a pair  $(x, y)$  with  $x \in P$  and  $y \in S$  is called a signed message

## IV. THE ELGAMAL SIGNATURE SCHEME

The ElGamal signature algorithm was presented by [5] in order to sign an online message  $x$  by Ade and sent across the network to a second person Ola for verification and authentication. According to ElGamal, Ade signs the message  $x$  with his secret random number  $k$  and private key  $a$ , which is only known to him, while Ola can verify the authenticity of the message  $x$  by using the public key  $p$ ,  $\alpha$ , and  $\beta$ . The ElGamal signature scheme is a non-deterministic algorithm where the verification algorithm is able to accept as many valid signatures as possible for any given message.

Let us examine the message  $x$  sent from Ade to Ola over an insecure communication network. The desire of Ade is to send the message safely over the network without any interception or disruption by intruders. However, a message sent over a communication network can be intercepted, examined, and modified due to the insecure nature of this network. Thus the problem of making a message authentic by signing it and subjecting it to verification electronically was developed by ElGamal. He designed a signature algorithm  $Sig_k(x, k)$  for Ade, that can be used sign message  $x$ , with his private key ( $a$ ) and secret number ( $k$ ), and verification algorithm  $Ver_k(x, (\gamma, \delta))$  in order to ascertain the authenticity and originality of the message  $x$  from Ade.

The algorithmic sequence of the **ElGamal Signature Scheme** is given as follow:

Given that  $p$  is a prime over  $Z_p$  where  $p = Z_p^*$ ,  $A = Z_p^* \times Z_{p-1}$ , and  
 $K = \{(p, \alpha, a, \beta); \beta \equiv \alpha^a \pmod{p}\}$ ,

where the values  $p$ ,  $\alpha$ , and  $\beta$  large prime number, public key, and private key respectively. The values  $P$ ,  $A$ ,  $Z_p$  are as defined previously.

$$\text{The signature Sig}_k(x, k) = (\gamma, \delta) \quad (1)$$

where

$$\gamma = \alpha^k \pmod{p} \quad (2)$$

and

$$\delta = (x - a\gamma) k^{-1} \pmod{p-1} \quad (3)$$

$k$  here is a (secret) random number used by Ade to sign the signature.

For  $x, \gamma \in Z_p$  and  $\delta \in Z_{p-1}$ , the verification of the algorithm is given as

$$\text{Ver}_k(x, (\gamma, \delta)) = \text{True} \Leftrightarrow$$

$$\beta^\gamma \gamma^\delta = \alpha^x \pmod{p} \quad (4)$$

It is worthwhile to note that if the signature was constructed correctly, then the verification will succeed, since  
 $\beta^\gamma \gamma^\delta = \alpha^{a\gamma} \alpha^{k\delta} \pmod{p} \equiv \alpha^x \pmod{p}$  (5)

Using the fact that

$$a\gamma + k\delta = x \pmod{p-1}$$

The verification can be accomplished by using only public information.

## V. VARIANT OF ELGAMAL SIGNATURE SCHEME

Various challenges characterize the ElGamal signature scheme and these range from authentication to privacy issues. The categories of Signature scheme, which are modification of the ElGamal Signature Scheme, were developed. Among these are Digital signature Scheme, Schnorr Signature Scheme, Elliptic curve Signature Scheme to mention a few. Due to the security requirement of signature scheme, various changes were made to ElGamal signature. It is highly imperative to be cautious regarding the security of a signature scheme, in which a signed message could perform a vital financial and legal transaction as opposed to a cryptosystem where a message might be encrypted and decrypted only once using any cryptosystem which is known to be secure at the time the message is being encrypted. Again, a signed message is very likely to be

verified over a period of time after the message has been signed.

Since the **ElGamal Scheme** is no more secure than the **Discrete Logarithm** problem, this necessitates the use of a large modulus  $p$ , which should have at least 512 bits and the length of  $p$  should be 1024 bits in order to provide security into the foreseeable future. However, for potential applications, such as smart cards application among others, a shorter signature is desirable.

### A. The Schnorr Signature Scheme

[9] proposed a signature scheme in which the size of the signature is greatly reduced. Schnorr proposed that suppose that  $p$  and  $q$  are primes such that  $p-1 \equiv 0 \pmod{q}$ , where  $p$  is taking as  $2^{1024}$  and  $q$  is approximately  $2^{160}$ . It modifies the ElGamal signature so that a  $\log_2 q$ -bit message digest is signed using a  $2\log_2 q$ -bit signature, while the computations are done in the  $Z_p$ . The Signature scheme is assumed secured based on the fact that the discrete logarithm specified in subgroup of set of prime closure ( $Z_p^*$ ) is more secured. The  $\alpha$  which is one of the public key use in verifying signed message is taking as  $q$ th root of 1 mod  $p$  i.e.  $\sqrt[q]{1 \pmod{p}}$ .

The algorithm of Schnorr Signature Scheme is described below:

Given that  $p$  is a large prime number such that the discrete log problem in  $Z_p^*$  is intractable, and  $q$  is a prime that divides  $p-1$ . Then the followings are in order by definitions:

$$\alpha = \sqrt[q]{1 \pmod{p}}$$

$$p = \{0,1\}^*$$

$$A = Z_q \times Z_q, \text{ and}$$

$$K = \{(p, q, \alpha, a, \beta): \beta \equiv \alpha^a \pmod{p}\}$$

where

$0 \leq a \leq q-1$ ,  $p, q, a$  and  $\beta$  are the public key, and  $a$  is the private key.

For  $K = (p, q, \alpha, a, \beta)$ , and for a secret key  $k$ ,  $1 \leq k \leq q-1$ ,

$$\text{Sig}_k(x, k) = (\gamma, \delta)$$

where

$$\gamma = h(x \parallel \alpha^k \pmod{p}) \text{ and}$$

$$\delta = k + a\gamma \pmod{p}$$

For  $x \in \{0,1\}^*$ , and  $\gamma, \delta \in Z_q$ , the signature can be verified through the following algorithmic process:

$$\text{Ver}_k(x, (\gamma, \delta)) = \text{True} \Leftrightarrow h(x \parallel \alpha^\delta \beta^{-\gamma} \pmod{p}) = \gamma$$

### A. The Digital Signature Standard (DSA)

The Digital signature Algorithm, 1994 (DSA) proposed by [2] is another modification of ElGalma Signature Scheme, which incorporates some characteristics of Schnorr Algorithm. The DSA was first published in the

Federal Register in May 19, 1994 and was finally adopted as a standard on December 1, 1994. DSS modifies the **ElGamal Scheme** in an ingenious way so that a 160-bit message is signed using a 320-bit signature, but the computations are done using a 512-bit modulus  $p$ . However, due to the criticisms from various quarters over the fixing of prime  $p$  value as 512-bits, the NIST altered the description of the standard and various modulus sizes can be used. The first change made is by changing the “-” to a “+” in equation 3 above, so that  $\delta$  becomes

$$\delta = (x + a\gamma) k^{-1} \pmod{p-1} \quad (6)$$

This changes the verification condition to the following:

$$\alpha^x \beta^y \equiv \gamma^\delta \pmod{p} \quad (7)$$

If  $\gcd(x+a\gamma, p-1) = 1$ , then  $\delta^{-1} \pmod{p-1}$  exists, and the equation (7) becomes:

$\alpha^{x\delta^{-1}} \beta^{y\delta^{-1}} \equiv \gamma \pmod{p}$  (8). Also, the message  $x$  in DSA should be hashed using SHA-1 before it is signed with a 320-bit signature over 160-bit message digest.

#### B. The Elliptic Curve DSA (ECDSA)

The Elliptic Curve Digital Signature Scheme as discussed by [11] and [12] is a modification of the Digital Signature Algorithm (DSA) to the setting of elliptic curves. There are two points  $P$  and  $Q$  on the elliptic curves, which are define over  $Z_p$  for some given prime number  $p$ . The private key of ECDSA is the discrete logarithm value  $m = \log_A B$ . In order to compute and verify a signature in this ECDSA, a (secret) number  $k$  is chosen randomly and the value of  $kA$  is computed.

Let  $p$  be a prime and  $E$  be an elliptic curve defined over  $F_p$ . Let  $A$  be a point on  $E$  having prime order  $q$ , such that the Discrete Logarithm problem in  $A$  is infeasible. Let

$P = \{0, 1\}^*$ ,  $A = Zq^* \times Zq^*$ , and define

$K = \{(p, q, E, A, m, B) : B = mA\}$ ,

Where  $0 \leq m \leq q-1$ . The value  $p, q, E, A$  and  $B$  are the public key, and  $m$  is the private key.

For a finite set of possible keys (keyspace),  $K$  and a (secret) random number  $k, 1 \leq k \leq q-1$ ,

$\text{Sig}_k(x, k) = (r, s)$ ,

where

$kA = (u, v)$

$r = u \pmod{q}$

$s = k^{-1}(\text{SHA-1}(x) + mr) \pmod{q}$

note: if either  $r$  or  $s = 0$ , then the new value of should be selected.

For all  $x \in \{0, 1\}^*$  and  $r, s \in Zq^*$ , verification  $\text{Ver}_k(x, (r, s)) = \text{true}$  if and only if  $u \pmod{q} = r$

Where  $w = s^{-1} \pmod{q}$

$i = w\text{SHA-1}(x) \pmod{q}$

$j = wr \pmod{q}$

$(u, v) = iA + jB$

## VI. MANUAL EXPERIMENTATIONS

These are some arithmetic examples and practical experiment based on the research work as stated as the examples depicted below:

### A. Example (ElGamal Signature Scheme)

Suppose we take  $p = 467, a = 4, \alpha = 101$ , we wish to verify the signature of Ade on a message

$x = 100$  and his (secrete) random key,  $k = 213$  and whether Ola should accept this signature; then

We compute:

$$\beta = \alpha^a \pmod{p} = 4^{101} \pmod{467} = 449$$

$$\gamma = \alpha^k \pmod{p} = 4^{213} \pmod{467} = 374$$

Suppose further that Ade chooses the random value  $k = 213$ , it is noted that great common divisor  $\gcd(213, 466) = 1$  and  $213^{-1} \pmod{466} = 431$

hence,

$$\begin{aligned} \delta &= (x - a\gamma) k^{-1} \pmod{p-1} = (100 - 374 * 101) * 431 \pmod{466} \\ &= (100 - 37774) * 431 \pmod{466} = - 37674 * 431 \\ &\pmod{466} = -16237494 \pmod{466} = - 190 + 466 = 276 \end{aligned}$$

The computational analysis yields:

$$\delta = 276, \gamma = 374$$

The signature 100 can therefore be verified by Ola or anyone by checking whether congruent  $\beta^y \gamma^\delta = \alpha^x \pmod{p}$  i.e

$\beta = 449, \delta = 276, \gamma = 374, x = 100, p = 467$  and  $a = 4$  then,

$$449^{374} 374^{276} = 4^{100} \pmod{467} = 229 \pmod{467}$$

This implies that the signature of Ade is valid and can be accepted by Ola or anyone that the message is sent to receive. Otherwise the signature should be rejected.

### B. Example (DSA)

Suppose Ade uses DSA with  $q = 101, p = 7879, \alpha = 170, a = 75$  and  $\beta = 4567$ . We wish to determine Ade's signature on a message  $x$  such that  $\text{SHA-1}(x) = 52$ , using a random value  $k = 49$  and find out whether the signature is authentic or forged.

Note: The value  $p, q, \alpha, \beta, a$ , are as defined previously in the signature algorithm

**Solution**

Given that  $q = 101$ ,  $p = 7879$ ,  $\alpha = 170$ ,  $\beta = 4567$ ,  $a = 75$ ,  $\text{SHA-1}(x) = 52$ ,  $k = 49$

The first step is to determine the signature of Ade on the message  $x$  by computing the following:

$$\begin{aligned} \gamma &= \alpha^k \pmod{p} \pmod{q} & (2) \\ &= 170^{49} \pmod{7879} \pmod{101} = 85 \\ \delta &= (\text{SHA-1}(x) + a\gamma) k^{-1} \pmod{q} \pmod{q} \\ &= (52 + 49 * 85) 49^{-1} \pmod{101} \pmod{101} = 84 \end{aligned}$$

The signature (85, 84) of Ade can therefore be verified by computing the following:

$$\begin{aligned} \delta^{-1} &= k^{-1} \pmod{q} = 49^{-1} \pmod{101} = 33 \\ e_1 &= \text{SHA-1}(x) \delta^{-1} \pmod{q} \\ &= 52 * 33 \pmod{101} = 100 \\ e_2 &= \gamma \delta^{-1} \pmod{q} \\ &= 85 * 33 \pmod{101} = 2805 \pmod{101} = 78 \end{aligned}$$

and

$$\begin{aligned} \text{Ver}_k(x, (\gamma, \delta)) &= \text{true} \Leftrightarrow \alpha^{e_1} \beta^{e_2} \pmod{p} \pmod{q} \\ &\Leftrightarrow 170^{100} 4567^{78} \pmod{7879} \pmod{101} = 85 \end{aligned}$$

Therefore the signature (85, 84) on message 100 should be accepted by Ade.

**C. Example (Schnorr Signature)**

Given that  $q = 101$ ,  $p = 88q + 1 = 7879$  where 3 is a primitive element in  $Z_{7879}$ , we want to verify the signature of Ade on a message  $x = 50$ , while he chooses random value  $k$  as 50 and  $a = 75$  where all the values are as defined earlier.

Then, we compute:

$$\alpha = 3^{88} \pmod{7879} = 484$$

but  $\alpha$  is a  $q$ th root of 1 modulo  $p$ . then

$$\beta = \alpha^a \pmod{7879} = 484^{75} \pmod{7879} = 4448 \text{ and}$$

$$\alpha^k \pmod{p} = 484^{50} \pmod{7879} = 3764$$

we can therefore compute the hash function  $h(x \parallel 3764)$  on a message  $x$  where 3764 is represented in binary (as a bit string). Thus

$$h(x \parallel 3764) = 97 \text{ and}$$

$$\delta = 50 + 75 * 97 \pmod{7879} = 53$$

and the signature  $(\gamma, \delta) = (97, 53)$

The signature can therefore be verified by computing and comparing the following:

$$\begin{aligned} \text{Ver}_k(x, (\gamma, \delta)) &= \text{True} \Leftrightarrow h(x \parallel \alpha^\delta \beta^{-\gamma} \pmod{p}) = \gamma \\ &\Leftrightarrow 484^{53} 4448^{-97} \pmod{7879} \neq \gamma \end{aligned}$$

The signature (97, 53) therefore cannot be verified on a message 50 over a given secret key 75.

**D.**

**Example (Elliptic Curve Signature)**

Consider the following elliptic curve  $y^2 = x^3 + x + 6$ , defined over  $Z_{11}$  with  $p = 11$ ,  $q = 13$ ,  $m = 23$   $A = (2, 7)$  and  $B = (2, 7)$ ,  $x$  with  $\text{SHA-1}(x) = 6$ ,  $k = 5$ . We wish to verify

whether a given signature  $(r, s)$  should be accepted or rejected.

**Solution**

We need to compute the following:

$$(u, v) = 5(2, 7) = (3, 6)$$

that is,

$$\begin{aligned} (u, v) &= iA + jB \\ r &= u \pmod{q} = 3 \pmod{13} = 3 \\ s &= k^{-1} \text{SHA-1}(x) + mr \pmod{q} \\ &= 5^{-1} (6 + 23 * 3) \pmod{13} = 15 \pmod{13} = \end{aligned}$$

2

$$w = s^{-1} \pmod{q} = 2^{-1} \pmod{13} = 7$$

$$i = w \text{SHA-1}(x) \pmod{q} = 7 * 6 \pmod{13} = 3$$

$$j = wr \pmod{q} = 7 * 3 \pmod{13} = 8$$

$$\text{Signature } (r, s) = (3, 2)$$

To verify the signature:

$$\text{Ver}_k(x, (r, s)) = \text{true if and only if } u \pmod{q} = r$$

that is,

$$u \pmod{q} = 3 \pmod{13} = 3.$$

Hence, the signature is accepted

**VII. REPORT ON THEORETICAL WORKED EXAMPLES**

The first theoretical example on Elgamal signature where the left hand side equation is equivalent to the right hand side i.e.  $449^{374} 374^{276} = 4^{100} \pmod{467} = 229 \pmod{46}$ , shows that the signature of Ade is valid and can be accepted by Ola or anyone. Otherwise the signature should be rejected. Also, the second example on DSA signature scheme where  $170^{100} 4567^{78} \pmod{7879} \pmod{101} = 85$  signified that the signature (85, 84) on message 100 is valid and should be accepted by Ade. However, the signature (97, 53) example of the schnorr signature example over a message 50 cannot be verified and therefore be rejected. The last example of elliptic curve signature also illustrates that the signature can be verified over an elliptic curve and since the calculated value of  $u \pmod{q} = r$ , then the signature should be accepted.

**VIII. AUTOMATA EXPERIMENTS BASED ON C++**

This section computes the various problems above using the equivalent algorithm:

Initialize the variable L,M,N,P;

Initialize variable A,B,R,a,K,X,Y,T,S as float

Collect the value of modulus P

Collect the value of primitive element A

Collect the value of value of B

Calculate  $a = (\log(B))/(\log(A))$

Display the private key a

Collect the value of R

Display R

Collect the value of value of S

Calculate  $K = (\log(R))/(\log(A));$

Collect the value of of K

Collect the value of message X

```
Display the verification details
L = pow (B,R);
M = pow (R,S);
N = pow (A,X);
If ((L*M)%P==N%P){ Then
Display the signature is true
Else display the signature is false
Display the verification is complete
return 0
End
```

#### A. Security Requirements for Signature Scheme

In order to make digital signature a reliable algorithm, it is highly essential for the algorithm to be logically “secured” in order to prevent various forms of attack from adversaries. This section examines the goal of an adversary, attack models and the security provided by signature scheme. Some possible attack models against digital signature are here under-listed:

- i) Known message attack: This attack occurs when adversary possesses a list of messages previously signed by his host, i.e.  $(x_1, x_2), \dots, (x_n, y_n)$  where  $x_i$ 's are random messages of Ade and  $y_i$ 's are his signatures on the messages so that  $y_i = \text{Sig}_k(x_i)$ ,  $i = 1, 2, 3, \dots$
- ii) Key- only attack: This is a vulnerable situation where public key of Ade is in the possession of adversary.
- iii) Total break: occurs when adversary is able to determine the private key of signer Ade and create valid signature on any message over signature function  $\text{Sig}_k$ .
- iv) Selective forgery where adversary is able to create a valid signature on a chosen message based on some probabilistic functions.
- v) Existential forgery: Adversary is able to create valid signature for at least one message on a pair  $(x, y)$ , where  $x$  is a message,  $y$  is a signature and  $\text{Ver}_k(x, y) = \text{true}$  while message  $x$  has not been previously signed.

#### IX. SECURITY ISSUES IN ELGAMAL SIGNATURE SCHEME

It is worthwhile in signature schemes to note that a message  $x$  signed and sent by Ade can be forged by another party. Suppose Ola attempt to forge a signature of Ade on a message  $x$ , without knowing the value of his private key  $a$ , he can choose the value  $\gamma$  and try to compute the corresponding  $\delta$ , however, doing this require him to compute the discrete logarithm  $\log \alpha^x \beta^{-\gamma}$ , which may be a little bit impossible. Alternatively, he can choose  $\delta$  and

compute  $\gamma$ , by solving the equation  $\beta^\gamma \gamma^\delta \equiv \alpha^x \pmod{p}$ . The implication of this is that for any unknown value  $\gamma$  or  $\delta$ , presently there is no feasible known solution. However, this is not sufficient to conclude that the value of signature  $(\gamma, \delta)$  cannot be computed.

In another way round, if an adversary chooses  $\gamma$  and  $\delta$  and attempt to find the value of message  $x$ , solving an instances of discrete logarithm problem became another challenge i.e. computing the value  $\log_a \beta^\gamma \gamma^\delta$ . However, if an adversary can choose  $\gamma$ ,  $\delta$  and random message  $x$  simultaneously, then he can perform what is known as existential forgery, where he can create one signature for at least one random message  $x$  while  $x$  has not previously being signed. i.e.  $\text{Ver}_k(x, y) = \text{true}$  where the message  $x$  has not been previously signed.

Summarily, the (secret) random value  $k$  used in computing the signature should be concealed because if  $k$  is known, an adversary can compute a private key  $a = (x - k\delta) \gamma^{-1} \pmod{p-1}$ . Also,  $k$  must not be used to sign two different message  $x$ .

#### X. FUTURE RESEARCH WORKS

In order to design a very secure signature algorithm, it is highly recommended that the (secret) random value  $k$  used in computing the signature should be concealed because if  $k$  is known, an adversary can compute a private key  $a = (x - k\delta) \gamma^{-1} \pmod{p-1}$ . Also,  $k$  must not be used to sign two different message  $x$ .

#### XI. DISCUSSION AND CONCLUSION

This paper has presented and examined various signature scheme algorithms with a view to simplify its complex mathematical aspect for a layman understanding. The signature scheme since its existence has become a veritable tool in securing the information on the Internet. However, it is quite notable that an information security is a continuous exercise that is subjecting to empirical analysis. The algorithms implemented in C++ programming language basically for better understanding and easier computation of perceived difficult aspects of cryptology.

Anybody can therefore; lay his hand on the implementation and compute the equivalents of various digital signature algorithms. The programming implementation also displays the speed of each of the algorithm.

#### XII. REFERENCES

- [1] Douglas R. Stinson, “Cryptography Theory and Practice”. University of Waterloo Ontario, Canada, Chapman & Hall/CRC. 2006.
- [2] Menezes, A. J. and Vanstone, S. A., “Advances in Cryptology”, volume 537 of Lecture Notes in Computer Science, Berlin, Springer, 1991.
- [3] Biham E. and Shami, A “Differential cryptanalysis of DES – like cryptosystem”. *Journal of Cryptology*, 4, pp. 3-72, 1991.
- [4] Schnorr, C. P. "Efficient Identification and Signatures for Smart Cards". *Proceedings of CRYPTO '89*. PP. 239 – 252.

Corresponding Author: **Olawale Surajudeen Adebayo (MCPN, MNCS)**

1989.

- [5] ElGamal, Taher, "A public key cryptosystem and a signature scheme based on discrete logarithms". *Advances in cryptology: Proceedings of CRYPTO 84*. Lecture Notes in Computer Science. **196**. Santa Barbara, California, United States: Springer-Verlag, pp. 10–18. doi:10.1007/3-540-39568-72, 1985.
- [6] Waziri, V.O "Information Security on the Internet in Nigeria with some functions of Cryptography", 10th Annual Conference proceeding, Nigerian Computer Society, Nicon Luxury, Abuja, Nigeria, 2011.
- [7] National Institute of Standards and Technology. Fact Sheet on Digital Signature Standard. Online, 1994. Accessible online at National Institute of Standards and Technology Website: [http://www.nist.gov/public\\_affairs/releases/digsigst.htm](http://www.nist.gov/public_affairs/releases/digsigst.htm).
- [8] Anderson, R. "Security Engineering: A Guild to Building Dependable Distributed System", John Willy and Sons.
- [9] Steinfeld R., Wang H., and Pieprzyk J., "Efficient extension of standard Schnorr / RSA signatures into universal designated-verifier signatures, Public Key Cryptography-PKC", LNCS Springer-Verlag, 2947, pp.86-100, 2004
- [10] Zhang, F. and Kim, K., "A universal forgery on Araki et al. 's convertible limited verifier signature scheme", IEICE Trans. Fundamentals, ol.E86-A, 2, pp. 515-516, 2003.
- [11] Hankerson, D., Menezes, A., and Vanstone, S.A., "Guide to Elliptic Curve Cryptography", Springer-Verlag, 2004.
- [12] Blake, I, Seroussi, G. and Smart, N., "Elliptic Curves in Cryptography", London Mathematical Society 265, Cambridge University Press, 1999.
- [13] Adebayo, O. S. and Waziri, V. O. "Information Security on the Communication Network in Nigeria Based on Digital Signature" In proceeding of 3rd International Conference on Mobile e-Services" Ladoko Akintola University, Ogbomoso, Nigeria, 25th – 27th, 2011.

computational intelligent. He has published some papers in the above-mentioned research areas.

He is a member of Computer Professional Registration Council of Nigeria (CPN), Nigeria Computer Society (NCS), Global Development Network, International Association of Computer Science and Information Technology and many others.

#### AUTHORS PROFILE



Olawale Surajudeen Adebayo (MCPN, MNCS, MIACSIT) is a lecturer in the department of Cyber security science department, Federal University of Technology, Minna, Niger State Nigeria. He bagged B.Tech. in Mathematics and Computer science from Federal University of Technology, Minna and the MSc. in Computer science from University of Ilorin, Kwara state, Nigeria. He is presently a PhD student in the department of cyber Security science, Federal University of Technology, Minna. His current research interests include: Information security, Cryptology, Machine learning, Data mining and

Corresponding Author: **Olawale Surajudeen Adebayo (MCPN, MNCS)**



## Requirements Elicitation For Software Projects

Samaher Abdullah AL-Hothali

Department of Computer Science and Engineering, Yanbu University College, Saudi Arabia.

Noor Abdulrahman AL-Zubaidi

.Department of Computer Science and Engineering, Yanbu University College, Saudi Arabia

Anusuyah Subbarao

Department of Computer Science and Engineering, Yanbu University College, Saudi Arabia.

**Abstract** - Requirements elicitation is the practice of collecting the requirements of a system from users, customers and other stakeholders. It is usually realized that requirements are elicited rather than just taking or gathering. This means there are discovery and development of elements to the elicitation process. Requirements elicitation is a complex process connecting with many activities with a different of available techniques, approaches, and tools for performing them. The objectives of this paper is to present the important aspects of how to plan for elicitation ,the techniques, approaches, and tools for requirements elicitation, and some elicitation problems.

**Keywords:** *requirements, elicitation, techniques, approaches, problems.*

### Introduction:

There are lots of problems linked with requirements engineering, including problems in defining the system scope, problems in development or enhance the understanding among the different

communities influenced by the development of a given system, and problems in dealing with the changing nature of requirements. These problems may lead to lack of requirements and the stopping of system development, or else the development of a system that is later judged wrong or unacceptable, has high servicing costs, or undergoes common changes.

The purpose of this paper is to provide the significant aspects of how to plan for elicitation, the techniques, approaches, and tools for requirements elicitation, and some elicitation troubles as elicitation troubles measured as a main problem area in the development of complex, software-intensive system.

### ANALYSIS

#### 1. What is elicitation

Elicitation indicates “to bring out, to evoke, and to call forth”; Requirements elicitation is “the process of discoverin

g the requirements for a system by communication with customers, system users and others who have a stake in the system development". Requirements elicitation is all about studying and comprehension the needs of users and project sponsors with the final aim of communicating these needs to the system developers.

## **2. Goal of elicitation**

The reason is to find information about : the domain model from which the requirements are written, the requirements from which system is developed.

## **3. Source of requirements**

There are different sources for requirements such as {Clients, Pre-existing systems (not necessarily computer systems), Pre-existing documentation, Users (pre-existing and potential) , Competing systems , Domain experts ,Documentation about interfacing systems ,Standards and legislation }.

## **4. Planning for elicitation** **Elicitation plan is the most important step to start any project.**

### **4.1 Objective**

Appoint what the elicitation is for.

### **4.2 Setting elicitation Strategies and processes**

Approaches that will be used, usually a collection of approaches such as (questioner, interview, Group Work, task analysis...etc)

## **4.3 Schedule and resource estimates**

Identify development and customer participants in different elicitation activities, guess of effort for elicitation and Scheduling.

## **4.4 Risks**

Factors that could block completion of elicitation activities, and you have to severity of each and every risk then, reduction strategy for each risk.

## **5. Elicitation Techniques and Approaches**

### **5.1 Interviews**

Interviews present an effective way to gather big number of data quickly.

#### **5.1.1 Planning and Preparation**

Essential to plan and prepare interviews by place goals and objectives for the interview, Prepare questions, get background knowledge of the subject matter, and organize the environment for performing an effective interview.

#### **5.1.2 Interview groups of people together to get Synergy**

Users can not think of everything they need when asked separately, however will remind more requirements when they hear others' needs. This relation is called synergy, the result by which group responses

outperform the sum of the individuals' responses.

### **5.1.3 Common interviewing mistakes**

Not interviewing all of the right people. Sometimes, asking direct questions too early. Interviewing one at a time instead of in small groups (More people might help get juices flowing as in brainstorming and reduces attention on individuals may produce more attractive answers) imagining that situation needs are exactly correct. Trying to encourage Stakeholders that You Are Smart .

### **5.2 Brainstorming**

Brainstorming [1] is a method where participants from different stakeholder groups connect in informal discussion to quickly produce as many ideas as possible without focusing on any one in particular. It is essential when conducting this type of group work to keep away from exploring or critiquing ideas in huge details. It is not usually the future reason of brainstorming sessions to decide major issues or make key decisions. This technique is often used to expand the introductory task statement for the project and target system. One of the advantages in using brainstorming is that it encourages freethinking and expression, and allows the discovery of new and ingenious solutions to existing problems.

### **5.3 Observation**

Observation is one of the more broadly used ethnographic techniques. As the

name suggests the analyst observes the real enforcement of existing processes by the users without direct interference. This technique is often used in combination with others such as interviews and task analysis. As a general rule ethnographic techniques such as observation are very expensive to perform and require important skill and effort on the part of the analyst to interpret and understand the actions being performed. The effectiveness of observation and other ethnographic techniques can differ as users have a tendency to correct the way they perform tasks when knowingly being watched.

### **5.4 Group Work**

Group work such as collaborative meetings is a very common and often default technique for requirements elicitation. Groups are mainly effective because they include and commit the stakeholders directly and enhance cooperation. These types of sessions can be hard to classify due to the number of different stakeholders that may be involved in the project. Organization these sessions effectively requires both expertise and experience to guarantee that individual personalities do not control the discussions. Key factors in the success of group work are the makeup of participants and the cohesion within the group. Stakeholders must feel comfortable and confident in speaking openly and honestly, and it is for this reason that group work is less effective in highly political situations.

## 5.5 Questionnaires

Questionnaires [2] are mostly used during the early stages of requirements elicitation and may consist of open and/or closed questions. For them to be useful, the terms, concepts, and boundaries of the domain must be well established and understood by the participants and questionnaire designer. Questions must be focused to stay away from gathering large amounts of redundant and irrelevant information. They provide an effective way to collect information from many stakeholders fast, but are limited in the depth of knowledge they are able to elicit. Questionnaires not have the opportunity to research further on a topic, or increase on new ideas. In the same way they present no technicality for the participants to request explanation or correct misunderstandings. Generally questionnaires are considered more helpful as informal checklists to ensure basic elements are addressed early on, and to establish the basis for following elicitation activities.

## 5.6 Laddering

When using laddering [3] stakeholders are asked a series of short encouragement questions, known as probes, and required to order the resulting answers into a planned structure. A main supposition when employing laddering is that the knowledge to be elicited can really be arranged in a hierarchical fashion. For this technique to be useful, the

stakeholders must be able to express their comprehension of the domain and then place it in a logical way. This knowledge which is often displayed using tree diagrams, is reviewed and modified dynamically as more is added. Like card sorting, laddering is mostly used as a way to clarify requirements and categorize domain entities.

## 5.7 Domain Analysis

Observe existing and related documentation and applications to collect early requirements as well as understand and take domain knowledge, and recognize reusable concepts and works.

## 5.8 Task Analysis

Task analysis [4, 5] uses a top-down approach where high-level tasks are spoiled into subtasks and finally detailed sequences until all actions and events are described. The main objectives of this technique is to build a hierarchy of the tasks performed by the users and the system, and decide the knowledge used or required to carry them out. Task analysis presents information on the interactions of both the user and the system with respect to the tasks as well as a background description of the activities that take place. In most cases considerable effort is necessary to perform thorough task analysis, and it is important to establish what level of detail is required and when works of the tasks need to be explorer more.

### **5.9 Apprenticing**

The analyst learns and performs the existing tasks under the instruction and supervision of an expert.

### **5.10 reflection**

The technique of introspection [6] requires the analyst to expand requirements based on what he or she believes the users and other stakeholders want and need from the system. Despite being employed by most analysts to some extent, this technique is mostly used only as an early point for other requirements elicitation efforts. Introspection is only really useful when the analyst is not only very familiar with the domain and goals of the system, but also specialist in the business processes achieved by the users. In cases where the analyst is forced to use this technique more, for instance when the users have little or no previous knowledge with software systems in their work environment, a type of facilitation introspection should take place via other elicitation techniques such as interviews and protocol analysis.

### **5.11 Prototyping**

Providing stakeholders with prototypes of the system to support the study of possible solutions is an effective way to gather detailed information and relevant feedback [7]. It is common

that prototypes are used in combination with other elicitation techniques such as interviews. Prototypes are typically developed using introductory requirements or existing examples of similar systems. This technique is particularly useful when developing human-computer interfaces, or where the stakeholders are unfamiliar with the available solutions. There are a number of different methods for prototyping systems such as storyboards, executable, throwaway and evolutionary, with changeable levels of effort required. In many cases prototypes are expensive to create in terms of time and cost. However, an advantage of using prototypes is that they support stakeholders, and more specifically the users, to play an active role in developing the requirements. One of the possibility risks when using prototypes for requirements elicitation is that users may become close to them, and therefore become resistant to alternative solutions from then on. Despite this the technique is very helpful when developing new systems for new applications.

## **6. Elicitation Problems and issues**

There has been small doubt in the past about the complexity and difficulty of requirements elicitation in most situations. We have classified some of the more commonly occurring issues and problems in requirements elicitation faced by both practitioners and researchers according to the aspect of requirements elicitation that they most relate to. These have been composed from a variety of sources in the literature [8] as well as from practical experience and observation.

#### **Interaction and comprehension**

It is familiar that stakeholders have difficulty articulating their requirements. In some cases this may be as a result of the analyst and stakeholders are not sharing a common understanding of concepts and terms, or the analyst is unfamiliar with the problem. Often stakeholders will have difficulty seeing new ways of doing things, or do not know the results of their requirements and as such may not know what is practical or true. Stakeholders may understand the problem domain very well, but are unfamiliar with the available solutions and the way in which their needs could be met. Alternatively stakeholders sometimes suggest solutions rather than requirements. Things that are

petty or always repeated by stakeholders are often supposed and overlooked although they may not be apparent to the analyst and other stakeholders.

#### **Process and Project**

Each project is unique and no two requirements elicitation situations are ever exactly the same. The process can be achieved as part of a custom software development project, COTS selection activity, product line definition, and existing system servicing operation. Projects can range all the way from simple recommended web-based applications to large and complex project information system product lines. The environment in which the process takes place can also vary greatly including the geographic distribution of stakeholders and the familiarity of users with software systems. Furthermore the process of requirements elicitation is inherently imprecise as a result of the multiple variable factors, large order of options and decision, and its communication and socially rich nature. Perhaps the most common project based requirements elicitation issue is that the first domain of the project has not been enough defined, and as such is open to interpretations and

suppositions. Projects like all purposes of a business are subject to change and influence from insider or outsider issues including economic, political, social, legal, financial, psychological, historical and geographical.

### **Quality of Requirements**

The requirements elicited may not be practical, cost-effective, or easy to validate.

In other cases they can be unclear, missing details, and not represented in such a way as can be measured or tested. Furthermore requirements may be defined at different and low levels of detail. Because the process of elicitation is informal by nature, a set of requirements may be incorrect, incomplete, inconsistent, and not clear to all stakeholders. The context in which requirements are elicited and the process itself is inherently unsteady. As the project develops and stakeholders become more familiar with the problem and solution domains, the goals of the system and the wants of the users are liable to change. In this way the

Process of elicitation can actually cause requirements volatility and therefore affect the quality of the requirements as a whole.

### **Stakeholders**

Conflicts between stakeholders and their requirements are common and almost unavoidable.

Furthermore stakeholders may not want to compromise or prefer their requirements when these conflicts occur. Sometimes stakeholders do not actually know what they want or what their real needs are, and are therefore limited in their ability to support the study of possible solutions. Also stakeholder can be opposite to the change a new system may introduce and therefore have varying levels of obligation and cooperation towards the project. Often stakeholders do not understand or appreciate the needs of the other stakeholders and might only be concerned with those factors that affect them directly. Like all humans, stakeholders can change their minds separately, or as a result of the elicitation process itself.

### **The “User and the Developer” Syndrome**

Characteristic	Response
Users do not know what they want, or they know what they want but cannot articulate it.	Recognize and appreciate the user as domain experts; try different techniques.
Users think they know what they want until developers give them what they said they wanted .	Provide alternative elicitation techniques earlier; storyboard ,role playing, prototypes and so on .
Analysts think they understand user problems better than users do .	Put the analyst in the users place . Try role playing for an hour or a day.
Everybody believes everybody else is politically motivated .	Yes , it is part of human nature, so let get on with the program.

Table 1- user and developer

## Conclusion

This research paper talks about requirements elicitation. The target of the paper is to present a definition of what a requirements elicitation is, and in the light of that definition, provide the main aspects of how to plan for requirements elicitation. Requirements elicitation is a collaborative decision-making activity involving users, developers, and customers. The elicitation approach is dependent not only on the variety and experience levels of these cross-disciplinary sources of requirements, but also the variety of the problem being made, which ranges from a fully understood system to a new, novel one. Any single approach to requirements elicitation will have varying success across different projects.

## References

[1] Osborn, A.F. (1979) *Applied Imagination*, Charles Scribner's Sons: New York.

[2] Faddy, W. (1994) *Constructing Questions for Interviews and Questionnaires*, Cambridge .University Press: Cambridge.

[3] Hinkle, D. (1965): *The change of personal constructs from the viewpoint of a theory of implications*, Ohio State University, Doctoral Dissertation.

[4] Carlshamre, P., Karlsson, J. (1996): *A usability-oriented approach to requirements engineering*, Proceedings of the Second International Conference on Requirements Engineering, pp. 145-152, April 15-18, Colorado Springs, CO.

[5] Richardson, J., Ormerod, T.C., Shepherd, A. (1998): *The Role of Task Analysis in Capturing Requirements for Interface Design*. *Interacting with Computers*, 9 (4), pp. 367-384.

[6] Goguen, J.A., Linde, C. (1993): *Techniques for Requirements Elicitation*, Proceedings of the IEEE International Symposium on Requirements Engineering, pp. 152-164, January 4-6, San Diego, CA.

[7] Sommerville, I. (2001): *Software Engineering 6th Edition*, Addison Wesley: USA.

[8] Christel, M.G., Kang, K.C. (1992): *Issues in Requirements Elicitation*, Carnegie Mellon University Technical Report, CMU/SEI-92-TR-012.



## IJCSIS REVIEWERS' LIST

Assist Prof (Dr.) M. Emre Celebi, Louisiana State University in Shreveport, USA  
Dr. Lam Hong Lee, Universiti Tunku Abdul Rahman, Malaysia  
Dr. Shimon K. Modi, Director of Research BSPA Labs, Purdue University, USA  
Dr. Jianguo Ding, Norwegian University of Science and Technology (NTNU), Norway  
Assoc. Prof. N. Jaisankar, VIT University, Vellore, Tamilnadu, India  
Dr. Amogh Kavimandan, The Mathworks Inc., USA  
Dr. Ramasamy Mariappan, Vinayaka Missions University, India  
Dr. Yong Li, School of Electronic and Information Engineering, Beijing Jiaotong University, P.R. China  
Assist. Prof. Sugam Sharma, NIET, India / Iowa State University, USA  
Dr. Jorge A. Ruiz-Vanoye, Universidad Autónoma del Estado de Morelos, Mexico  
Dr. Neeraj Kumar, SMVD University, Katra (J&K), India  
Dr Genge Bela, "Petru Maior" University of Targu Mures, Romania  
Dr. Junjie Peng, Shanghai University, P. R. China  
Dr. Ilhem LENGILIZ, HANA Group - CRISTAL Laboratory, Tunisia  
Prof. Dr. Durgesh Kumar Mishra, Acropolis Institute of Technology and Research, Indore, MP, India  
Jorge L. Hernández-Ardieta, University Carlos III of Madrid, Spain  
Prof. Dr.C.Suresh Gnana Dhas, Anna University, India  
Mrs Li Fang, Nanyang Technological University, Singapore  
Prof. Pijush Biswas, RCC Institute of Information Technology, India  
Dr. Siddhivinayak Kulkarni, University of Ballarat, Ballarat, Victoria, Australia  
Dr. A. Arul Lawrence, Royal College of Engineering & Technology, India  
Mr. Wongyos Keardsri, Chulalongkorn University, Bangkok, Thailand  
Mr. Somesh Kumar Dewangan, CSVTU Bhilai (C.G.)/ Dimat Raipur, India  
Mr. Hayder N. Jasem, University Putra Malaysia, Malaysia  
Mr. A.V.Senthil Kumar, C. M. S. College of Science and Commerce, India  
Mr. R. S. Karthik, C. M. S. College of Science and Commerce, India  
Mr. P. Vasant, University Technology Petronas, Malaysia  
Mr. Wong Kok Seng, Soongsil University, Seoul, South Korea  
Mr. Praveen Ranjan Srivastava, BITS PILANI, India  
Mr. Kong Sang Kelvin, Leong, The Hong Kong Polytechnic University, Hong Kong  
Mr. Mohd Nazri Ismail, Universiti Kuala Lumpur, Malaysia  
Dr. Rami J. Matarneh, Al-isra Private University, Amman, Jordan  
Dr Ojesanmi Olusegun Ayodeji, Ajayi Crowther University, Oyo, Nigeria  
Dr. Riktresh Srivastava, Skyline University, UAE  
Dr. Oras F. Baker, UCSI University - Kuala Lumpur, Malaysia  
Dr. Ahmed S. Ghiduk, Faculty of Science, Beni-Suef University, Egypt  
and Department of Computer science, Taif University, Saudi Arabia  
Mr. Tirthankar Gayen, IIT Kharagpur, India  
Ms. Huei-Ru Tseng, National Chiao Tung University, Taiwan

Prof. Ning Xu, Wuhan University of Technology, China  
Mr Mohammed Salem Binwahlan, Hadhramout University of Science and Technology, Yemen  
& Universiti Teknologi Malaysia, Malaysia.  
Dr. Aruna Ranganath, Bhoj Reddy Engineering College for Women, India  
Mr. Hafeezullah Amin, Institute of Information Technology, KUST, Kohat, Pakistan  
Prof. Syed S. Rizvi, University of Bridgeport, USA  
Mr. Shahbaz Pervez Chattha, University of Engineering and Technology Taxila, Pakistan  
Dr. Shishir Kumar, Jaypee University of Information Technology, Wakanaghat (HP), India  
Mr. Shahid Mumtaz, Portugal Telecommunication, Instituto de Telecomunicações (IT) , Aveiro, Portugal  
Mr. Rajesh K Shukla, Corporate Institute of Science & Technology Bhopal M P  
Dr. Poonam Garg, Institute of Management Technology, India  
Mr. S. Mehta, Inha University, Korea  
Mr. Dilip Kumar S.M, University Visvesvaraya College of Engineering (UVCE), Bangalore University,  
Bangalore  
Prof. Malik Sikander Hayat Khiyal, Fatima Jinnah Women University, Rawalpindi, Pakistan  
Dr. Virendra Gomase , Department of Bioinformatics, Padmashree Dr. D.Y. Patil University  
Dr. Irraivan Elamvazuthi, University Technology PETRONAS, Malaysia  
Mr. Saqib Saeed, University of Siegen, Germany  
Mr. Pavan Kumar Gorakavi, IPMA-USA [YC]  
Dr. Ahmed Nabih Zaki Rashed, Menoufia University, Egypt  
Prof. Shishir K. Shandilya, Rukmani Devi Institute of Science & Technology, India  
Mrs.J.Komala Lakshmi, SNR Sons College, Computer Science, India  
Mr. Muhammad Sohail, KUST, Pakistan  
Dr. Manjaiah D.H, Mangalore University, India  
Dr. S Santhosh Baboo, D.G.Vaishnav College, Chennai, India  
Prof. Dr. Mokhtar Beldjehem, Sainte-Anne University, Halifax, NS, Canada  
Dr. Deepak Laxmi Narasimha, Faculty of Computer Science and Information Technology, University of  
Malaya, Malaysia  
Prof. Dr. Arunkumar Thangavelu, Vellore Institute Of Technology, India  
Mr. M. Azath, Anna University, India  
Mr. Md. Rabiul Islam, Rajshahi University of Engineering & Technology (RUET), Bangladesh  
Mr. Aos Alaa Zaidan Ansaef, Multimedia University, Malaysia  
Dr Suresh Jain, Professor (on leave), Institute of Engineering & Technology, Devi Ahilya University, Indore  
(MP) India,  
Dr. Mohammed M. Kadhum, Universiti Utara Malaysia  
Mr. Hanumanthappa. J. University of Mysore, India  
Mr. Syed Ishtiaque Ahmed, Bangladesh University of Engineering and Technology (BUET)  
Mr Akinola Solomon Olalekan, University of Ibadan, Ibadan, Nigeria  
Mr. Santosh K. Pandey, Department of Information Technology, The Institute of Chartered Accountants of  
India  
Dr. P. Vasant, Power Control Optimization, Malaysia  
Dr. Petr Ivankov, Automatika - S, Russian Federation

Dr. Utkarsh Seetha, Data Infosys Limited, India  
Mrs. Priti Maheshwary, Maulana Azad National Institute of Technology, Bhopal  
Dr. (Mrs) Padmavathi Ganapathi, Avinashilingam University for Women, Coimbatore  
Assist. Prof. A. Neela madheswari, Anna university, India  
Prof. Ganesan Ramachandra Rao, PSG College of Arts and Science, India  
Mr. Kamanashis Biswas, Daffodil International University, Bangladesh  
Dr. Atul Gonsai, Saurashtra University, Gujarat, India  
Mr. Angkoon Phinyomark, Prince of Songkla University, Thailand  
Mrs. G. Nalini Priya, Anna University, Chennai  
Dr. P. Subashini, Avinashilingam University for Women, India  
Assoc. Prof. Vijay Kumar Chakka, Dhirubhai Ambani IICT, Gandhinagar ,Gujarat  
Mr Jitendra Agrawal, : Rajiv Gandhi Proudhyogiki Vishwavidyalaya, Bhopal  
Mr. Vishal Goyal, Department of Computer Science, Punjabi University, India  
Dr. R. Baskaran, Department of Computer Science and Engineering, Anna University, Chennai  
Assist. Prof, Kanwalvir Singh Dhindsa, B.B.S.B.Engg.College, Fatehgarh Sahib (Punjab), India  
Dr. Jamal Ahmad Dargham, School of Engineering and Information Technology, Universiti Malaysia Sabah  
Mr. Nitin Bhatia, DAV College, India  
Dr. Dhavachelvan Ponnurangam, Pondicherry Central University, India  
Dr. Mohd Faizal Abdollah, University of Technical Malaysia, Malaysia  
Assist. Prof. Sonal Chawla, Panjab University, India  
Dr. Abdul Wahid, AKG Engg. College, Ghaziabad, India  
Mr. Arash Habibi Lashkari, University of Malaya (UM), Malaysia  
Mr. Md. Rajibul Islam, Ibnu Sina Institute, University Technology Malaysia  
Professor Dr. Sabu M. Thampi, .B.S Institute of Technology for Women, Kerala University, India  
Mr. Noor Muhammed Nayeem, Université Lumière Lyon 2, 69007 Lyon, France  
Dr. Himanshu Aggarwal, Department of Computer Engineering, Punjabi University, India  
Prof R. Naidoo, Dept of Mathematics/Center for Advanced Computer Modelling, Durban University of  
Technology, Durban,South Africa  
Prof. Mydhili K Nair, M S Ramaiah Institute of Technology(M.S.R.I.T), Affiliated to Visweswaraiah  
Technological University, Bangalore, India  
M. Prabu, Adhiyamaan College of Engineering/Anna University, India  
Mr. Swakkhar Shatabda, Department of Computer Science and Engineering, United International University,  
Bangladesh  
Dr. Abdur Rashid Khan, ICIT, Gomal University, Dera Ismail Khan, Pakistan  
Mr. H. Abdul Shabeer, I-Nautix Technologies,Chennai, India  
Dr. M. Aramudhan, Perunthalaivar Kamarajar Institute of Engineering and Technology, India  
Dr. M. P. Thapliyal, Department of Computer Science, HNB Garhwal University (Central University), India  
Dr. Shahaboddin Shamshirband, Islamic Azad University, Iran  
Mr. Zeashan Hameed Khan, : Université de Grenoble, France  
Prof. Anil K Ahlawat, Ajay Kumar Garg Engineering College, Ghaziabad, UP Technical University, Lucknow  
Mr. Longe Olumide Babatope, University Of Ibadan, Nigeria  
Associate Prof. Raman Maini, University College of Engineering, Punjabi University, India

Dr. Maslin Masrom, University Technology Malaysia, Malaysia  
Sudipta Chattopadhyay, Jadavpur University, Kolkata, India  
Dr. Dang Tuan NGUYEN, University of Information Technology, Vietnam National University - Ho Chi Minh City  
Dr. Mary Lourde R., BITS-PILANI Dubai , UAE  
Dr. Abdul Aziz, University of Central Punjab, Pakistan  
Mr. Karan Singh, Gautam Budtha University, India  
Mr. Avinash Pokhriyal, Uttar Pradesh Technical University, Lucknow, India  
Associate Prof Dr Zuraini Ismail, University Technology Malaysia, Malaysia  
Assistant Prof. Yasser M. Alginahi, College of Computer Science and Engineering, Taibah University, Madinah Munawwarrah, KSA  
Mr. Dakshina Ranjan Kisku, West Bengal University of Technology, India  
Mr. Raman Kumar, Dr B R Ambedkar National Institute of Technology, Jalandhar, Punjab, India  
Associate Prof. Samir B. Patel, Institute of Technology, Nirma University, India  
Dr. M.Munir Ahamed Rabbani, B. S. Abdur Rahman University, India  
Asst. Prof. Koushik Majumder, West Bengal University of Technology, India  
Dr. Alex Pappachen James, Queensland Micro-nanotechnology center, Griffith University, Australia  
Assistant Prof. S. Hariharan, B.S. Abdur Rahman University, India  
Asst Prof. Jasmine. K. S, R.V.College of Engineering, India  
Mr Naushad Ali Mamode Khan, Ministry of Education and Human Resources, Mauritius  
Prof. Mahesh Goyani, G H Patel Collge of Engg. & Tech, V.V.N, Anand, Gujarat, India  
Dr. Mana Mohammed, University of Tlemcen, Algeria  
Prof. Jatinder Singh, Universal Institutiion of Engg. & Tech. CHD, India  
Mrs. M. Anandhavalli Gauthaman, Sikkim Manipal Institute of Technology, Majitar, East Sikkim  
Dr. Bin Guo, Institute Telecom SudParis, France  
Mrs. Maleika Mehr Nigar Mohamed Heenaye-Mamode Khan, University of Mauritius  
Prof. Pijush Biswas, RCC Institute of Information Technology, India  
Mr. V. Bala Dhandayuthapani, Mekelle University, Ethiopia  
Dr. Irfan Syamsuddin, State Polytechnic of Ujung Pandang, Indonesia  
Mr. Kavi Kumar Khedo, University of Mauritius, Mauritius  
Mr. Ravi Chandiran, Zagro Singapore Pte Ltd. Singapore  
Mr. Milindkumar V. Sarode, Jawaharlal Darda Institute of Engineering and Technology, India  
Dr. Shamimul Qamar, KSJ Institute of Engineering & Technology, India  
Dr. C. Arun, Anna University, India  
Assist. Prof. M.N.Birje, Basaveshwar Engineering College, India  
Prof. Hamid Reza Najji, Department of Computer Enigneering, Shahid Beheshti University, Tehran, Iran  
Assist. Prof. Debasis Giri, Department of Computer Science and Engineering, Haldia Institute of Technology  
Subhabrata Barman, Haldia Institute of Technology, West Bengal  
Mr. M. I. Lali, COMSATS Institute of Information Technology, Islamabad, Pakistan  
Dr. Feroz Khan, Central Institute of Medicinal and Aromatic Plants, Lucknow, India  
Mr. R. Nagendran, Institute of Technology, Coimbatore, Tamilnadu, India  
Mr. Amnach Khawne, King Mongkut's Institute of Technology Ladkrabang, Ladkrabang, Bangkok, Thailand

Dr. P. Chakrabarti, Sir Padampat Singhanian University, Udaipur, India  
Mr. Nafiz Imtiaz Bin Hamid, Islamic University of Technology (IUT), Bangladesh.  
Shahab-A. Shamshirband, Islamic Azad University, Chalous, Iran  
Prof. B. Priestly Shan, Anna Univeristy, Tamilnadu, India  
Venkatramreddy Velma, Dept. of Bioinformatics, University of Mississippi Medical Center, Jackson MS USA  
Akshi Kumar, Dept. of Computer Engineering, Delhi Technological University, India  
Dr. Umesh Kumar Singh, Vikram University, Ujjain, India  
Mr. Serguei A. Mokhov, Concordia University, Canada  
Mr. Lai Khin Wee, Universiti Teknologi Malaysia, Malaysia  
Dr. Awadhesh Kumar Sharma, Madan Mohan Malviya Engineering College, India  
Mr. Syed R. Rizvi, Analytical Services & Materials, Inc., USA  
Dr. S. Karthik, SNS College of Technology, India  
Mr. Syed Qasim Bukhari, CIMET (Universidad de Granada), Spain  
Mr. A.D.Potgantwar, Pune University, India  
Dr. Himanshu Aggarwal, Punjabi University, India  
Mr. Rajesh Ramachandran, Naipunya Institute of Management and Information Technology, India  
Dr. K.L. Shunmuganathan, R.M.K Engg College , Kavaraipettai ,Chennai  
Dr. Prasant Kumar Pattnaik, KIST, India.  
Dr. Ch. Aswani Kumar, VIT University, India  
Mr. Ijaz Ali Shoukat, King Saud University, Riyadh KSA  
Mr. Arun Kumar, Sir Padam Pat Singhanian University, Udaipur, Rajasthan  
Mr. Muhammad Imran Khan, Universiti Teknologi PETRONAS, Malaysia  
Dr. Natarajan Meghanathan, Jackson State University, Jackson, MS, USA  
Mr. Mohd Zaki Bin Mas'ud, Universiti Teknikal Malaysia Melaka (UTeM), Malaysia  
Prof. Dr. R. Geetharamani, Dept. of Computer Science and Eng., Rajalakshmi Engineering College, India  
Dr. Smita Rajpal, Institute of Technology and Management, Gurgaon, India  
Dr. S. Abdul Khader Jilani, University of Tabuk, Tabuk, Saudi Arabia  
Mr. Syed Jamal Haider Zaidi, Bahria University, Pakistan  
Dr. N. Devarajan, Government College of Technology, Coimbatore, Tamilnadu, INDIA  
Mr. R. Jagadeesh Kannan, RMK Engineering College, India  
Mr. Deo Prakash, Shri Mata Vaishno Devi University, India  
Mr. Mohammad Abu Naser, Dept. of EEE, IUT, Gazipur, Bangladesh  
Assist. Prof. Prasun Ghosal, Bengal Engineering and Science University, India  
Mr. Md. Golam Kaosar, School of Engineering and Science, Victoria University, Melbourne City, Australia  
Mr. R. Mahammad Shafi, Madanapalle Institute of Technology & Science, India  
Dr. F.Sagayaraj Francis, Pondicherry Engineering College, India  
Dr. Ajay Goel, HIET , Kaithal, India  
Mr. Nayak Sunil Kashibarao, Bahirji Smarak Mahavidyalaya, India  
Mr. Suhas J Manangi, Microsoft India  
Dr. Kalyankar N. V., Yeshwant Mahavidyalaya, Nanded , India  
Dr. K.D. Verma, S.V. College of Post graduate studies & Research, India  
Dr. Amjad Rehman, University Technology Malaysia, Malaysia

Mr. Rachit Garg, L K College, Jalandhar, Punjab  
Mr. J. William, M.A.M college of Engineering, Trichy, Tamilnadu, India  
Prof. Jue-Sam Chou, Nanhua University, College of Science and Technology, Taiwan  
Dr. Thorat S.B., Institute of Technology and Management, India  
Mr. Ajay Prasad, Sir Padampat Singhania University, Udaipur, India  
Dr. Kamaljit I. Lakhtaria, Atmiya Institute of Technology & Science, India  
Mr. Syed Rafiul Hussain, Ahsanullah University of Science and Technology, Bangladesh  
Mrs Fazeela Tunnisa, Najran University, Kingdom of Saudi Arabia  
Mrs Kavita Taneja, Maharishi Markandeshwar University, Haryana, India  
Mr. Maniyar Shiraz Ahmed, Najran University, Najran, KSA  
Mr. Anand Kumar, AMC Engineering College, Bangalore  
Dr. Rakesh Chandra Gangwar, Beant College of Engg. & Tech., Gurdaspur (Punjab) India  
Dr. V V Rama Prasad, Sree Vidyanikethan Engineering College, India  
Assist. Prof. Neetesh Kumar Gupta, Technocrats Institute of Technology, Bhopal (M.P.), India  
Mr. Ashish Seth, Uttar Pradesh Technical University, Lucknow, UP India  
Dr. V V S S S Balaram, Sreenidhi Institute of Science and Technology, India  
Mr Rahul Bhatia, Lingaya's Institute of Management and Technology, India  
Prof. Niranjana Reddy. P, KITS, Warangal, India  
Prof. Rakesh. Lingappa, Vijetha Institute of Technology, Bangalore, India  
Dr. Mohammed Ali Hussain, Nimra College of Engineering & Technology, Vijayawada, A.P., India  
Dr. A.Srinivasan, MNM Jain Engineering College, Rajiv Gandhi Salai, Thorapakkam, Chennai  
Mr. Rakesh Kumar, M.M. University, Mullana, Ambala, India  
Dr. Lena Khaled, Zarqa Private University, Aman, Jordan  
Ms. Supriya Kapoor, Patni/Lingaya's Institute of Management and Tech., India  
Dr. Tossapon Boongoen, Aberystwyth University, UK  
Dr. Bilal Alatas, Firat University, Turkey  
Assist. Prof. Jyoti Praaksh Singh, Academy of Technology, India  
Dr. Ritu Soni, GNG College, India  
Dr. Mahendra Kumar, Sagar Institute of Research & Technology, Bhopal, India.  
Dr. Binod Kumar, Lakshmi Narayan College of Tech.(LNCT) Bhopal India  
Dr. Muzhir Shaban Al-Ani, Amman Arab University Amman – Jordan  
Dr. T.C. Manjunath, ATRIA Institute of Tech, India  
Mr. Muhammad Zakarya, COMSATS Institute of Information Technology (CIIT), Pakistan  
Assist. Prof. Harmunish Taneja, M. M. University, India  
Dr. Chitra Dhawale, SICSAR, Model Colony, Pune, India  
Mrs Sankari Muthukaruppan, Nehru Institute of Engineering and Technology, Anna University, India  
Mr. Aaqif Afzaal Abbasi, National University Of Sciences And Technology, Islamabad  
Prof. Ashutosh Kumar Dubey, Trinity Institute of Technology and Research Bhopal, India  
Mr. G. Appasami, Dr. Pauls Engineering College, India  
Mr. M Yasin, National University of Science and Tech, Karachi (NUST), Pakistan  
Mr. Yaser Miaji, University Utara Malaysia, Malaysia  
Mr. Shah Ahsanul Haque, International Islamic University Chittagong (IIUC), Bangladesh

Prof. (Dr) Syed Abdul Sattar, Royal Institute of Technology & Science, India  
Dr. S. Sasikumar, Roever Engineering College  
Assist. Prof. Monit Kapoor, Maharishi Markandeshwar University, India  
Mr. Nwaocha Vivian O, National Open University of Nigeria  
Dr. M. S. Vijaya, GR Govindarajulu School of Applied Computer Technology, India  
Assist. Prof. Chakresh Kumar, Manav Rachna International University, India  
Mr. Kunal Chadha , R&D Software Engineer, Gemalto, Singapore  
Mr. Mueen Uddin, Universiti Teknologi Malaysia, UTM , Malaysia  
Dr. Dhuha Basheer abdullah, Mosul university, Iraq  
Mr. S. Audithan, Annamalai University, India  
Prof. Vijay K Chaudhari, Technocrats Institute of Technology , India  
Associate Prof. Mohd Ilyas Khan, Technocrats Institute of Technology , India  
Dr. Vu Thanh Nguyen, University of Information Technology, HoChiMinh City, VietNam  
Assist. Prof. Anand Sharma, MITS, Lakshmandarh, Sikar, Rajasthan, India  
Prof. T V Narayana Rao, HITAM Engineering college, Hyderabad  
Mr. Deepak Gour, Sir Padampat Singhania University, India  
Assist. Prof. Amutharaj Joyson, Kalasalingam University, India  
Mr. Ali Balador, Islamic Azad University, Iran  
Mr. Mohit Jain, Maharaja Surajmal Institute of Technology, India  
Mr. Dilip Kumar Sharma, GLA Institute of Technology & Management, India  
Dr. Debojyoti Mitra, Sir padampat Singhania University, India  
Dr. Ali Dehghantanha, Asia-Pacific University College of Technology and Innovation, Malaysia  
Mr. Zhao Zhang, City University of Hong Kong, China  
Prof. S.P. Setty, A.U. College of Engineering, India  
Prof. Patel Rakeshkumar Kantilal, Sankalchand Patel College of Engineering, India  
Mr. Biswajit Bhowmik, Bengal College of Engineering & Technology, India  
Mr. Manoj Gupta, Apex Institute of Engineering & Technology, India  
Assist. Prof. Ajay Sharma, Raj Kumar Goel Institute Of Technology, India  
Assist. Prof. Ramveer Singh, Raj Kumar Goel Institute of Technology, India  
Dr. Hanan Elazhary, Electronics Research Institute, Egypt  
Dr. Hosam I. Faiq, USM, Malaysia  
Prof. Dipti D. Patil, MAEER's MIT College of Engg. & Tech, Pune, India  
Assist. Prof. Devendra Chack, BCT Kumaon engineering College Dwarahat Almora, India  
Prof. Manpreet Singh, M. M. Engg. College, M. M. University, India  
Assist. Prof. M. Sadiq ali Khan, University of Karachi, Pakistan  
Mr. Prasad S. Halgaonkar, MIT - College of Engineering, Pune, India  
Dr. Imran Ghani, Universiti Teknologi Malaysia, Malaysia  
Prof. Varun Kumar Kakar, Kumaon Engineering College, Dwarahat, India  
Assist. Prof. Nisheeth Joshi, Apaji Institute, Banasthali University, Rajasthan, India  
Associate Prof. Kunwar S. Vaisla, VCT Kumaon Engineering College, India  
Prof Anupam Choudhary, Bhilai School Of Engg.,Bhilai (C.G.),India  
Mr. Divya Prakash Shrivastava, Al Jabal Al garbi University, Zawya, Libya

Associate Prof. Dr. V. Radha, Avinashilingam Deemed university for women, Coimbatore.  
Dr. Kasarapu Ramani, JNT University, Anantapur, India  
Dr. Anuraag Awasthi, Jayoti Vidyapeeth Womens University, India  
Dr. C G Ravichandran, R V S College of Engineering and Technology, India  
Dr. Mohamed A. Deriche, King Fahd University of Petroleum and Minerals, Saudi Arabia  
Mr. Abbas Karimi, Universiti Putra Malaysia, Malaysia  
Mr. Amit Kumar, Jaypee University of Engg. and Tech., India  
Dr. Nikolai Stoianov, Defense Institute, Bulgaria  
Assist. Prof. S. Ranichandra, KSR College of Arts and Science, Tiruchencode  
Mr. T.K.P. Rajagopal, Diamond Horse International Pvt Ltd, India  
Dr. Md. Ekramul Hamid, Rajshahi University, Bangladesh  
Mr. Hemanta Kumar Kalita , TATA Consultancy Services (TCS), India  
Dr. Messaouda Azzouzi, Ziane Achour University of Djelfa, Algeria  
Prof. (Dr.) Juan Jose Martinez Castillo, "Gran Mariscal de Ayacucho" University and Acantelys research Group, Venezuela  
Dr. Jatinderkumar R. Saini, Narmada College of Computer Application, India  
Dr. Babak Bashari Rad, University Technology of Malaysia, Malaysia  
Dr. Nighat Mir, Effat University, Saudi Arabia  
Prof. (Dr.) G.M.Nasira, Sasurie College of Engineering, India  
Mr. Varun Mittal, Gemalto Pte Ltd, Singapore  
Assist. Prof. Mrs P. Banumathi, Kathir College Of Engineering, Coimbatore  
Assist. Prof. Quan Yuan, University of Wisconsin-Stevens Point, US  
Dr. Pranam Paul, Narula Institute of Technology, Agarpara, West Bengal, India  
Assist. Prof. J. Ramkumar, V.L.B Janakiammal college of Arts & Science, India  
Mr. P. Sivakumar, Anna university, Chennai, India  
Mr. Md. Humayun Kabir Biswas, King Khalid University, Kingdom of Saudi Arabia  
Mr. Mayank Singh, J.P. Institute of Engg & Technology, Meerut, India  
HJ. Kamaruzaman Jusoff, Universiti Putra Malaysia  
Mr. Nikhil Patrick Lobo, CADES, India  
Dr. Amit Wason, Rayat-Bahra Institute of Engineering & Boi-Technology, India  
Dr. Rajesh Shrivastava, Govt. Benazir Science & Commerce College, Bhopal, India  
Assist. Prof. Vishal Bharti, DCE, Gurgaon  
Mrs. Sunita Bansal, Birla Institute of Technology & Science, India  
Dr. R. Sudhakar, Dr.Mahalingam college of Engineering and Technology, India  
Dr. Amit Kumar Garg, Shri Mata Vaishno Devi University, Katra(J&K), India  
Assist. Prof. Raj Gaurang Tiwari, AZAD Institute of Engineering and Technology, India  
Mr. Hamed Taherdoost, Tehran, Iran  
Mr. Amin Daneshmand Malayeri, YRC, IAU, Malayer Branch, Iran  
Mr. Shantanu Pal, University of Calcutta, India  
Dr. Terry H. Walcott, E-Promag Consultancy Group, United Kingdom  
Dr. Ezekiel U OKIKE, University of Ibadan, Nigeria  
Mr. P. Mahalingam, Caledonian College of Engineering, Oman



Dr. Mahmoud M. A. Abd Ellatif, Mansoura University, Egypt  
Prof. Kunwar S. Vaisla, BCT Kumaon Engineering College, India  
Prof. Mahesh H. Panchal, Kalol Institute of Technology & Research Centre, India  
Mr. Muhammad Asad, Technical University of Munich, Germany  
Mr. AliReza Shams Shafigh, Azad Islamic university, Iran  
Prof. S. V. Nagaraj, RMK Engineering College, India  
Mr. Ashikali M Hasan, Senior Researcher, CelNet security, India  
Dr. Adnan Shahid Khan, University Technology Malaysia, Malaysia  
Mr. Prakash Gajanan Burade, Nagpur University/ITM college of engg, Nagpur, India  
Dr. Jagdish B.Helonde, Nagpur University/ITM college of engg, Nagpur, India  
Professor, Doctor BOUHORMA Mohammed, Univertsity Abdelmalek Essaadi, Morocco  
Mr. K. Thirumalaivasan, Pondicherry Engg. College, India  
Mr. Umbarkar Anantkumar Janardan, Walchand College of Engineering, India  
Mr. Ashish Chaurasia, Gyan Ganga Institute of Technology & Sciences, India  
Mr. Sunil Taneja, Kurukshetra University, India  
Mr. Fauzi Adi Rafrastara, Dian Nuswantoro University, Indonesia  
Dr. Yaduvir Singh, Thapar University, India  
Dr. Ioannis V. Koskosas, University of Western Macedonia, Greece  
Dr. Vasantha Kalyani David, Avinashilingam University for women, Coimbatore  
Dr. Ahmed Mansour Manasrah, Universiti Sains Malaysia, Malaysia  
Miss. Nazanin Sadat Kazazi, University Technology Malaysia, Malaysia  
Mr. Saeed Rasouli Heikalabad, Islamic Azad University - Tabriz Branch, Iran  
Assoc. Prof. Dharendra Mishra, SVKM's NMIMS University, India  
Prof. Shapoor Zarei, UAE Inventors Association, UAE  
Prof. B.Raja Sarath Kumar, Lenora College of Engineering, India  
Dr. Bashir Alam, Jamia millia Islamia, Delhi, India  
Prof. Anant J Umbarkar, Walchand College of Engg., India  
Assist. Prof. B. Bharathi, Sathyabama University, India  
Dr. Fokrul Alom Mazarbhuiya, King Khalid University, Saudi Arabia  
Prof. T.S.Jeyali Laseeth, Anna University of Technology, Tirunelveli, India  
Dr. M. Balraju, Jawahar Lal Nehru Technological University Hyderabad, India  
Dr. Vijayalakshmi M. N., R.V.College of Engineering, Bangalore  
Prof. Walid Moudani, Lebanese University, Lebanon  
Dr. Saurabh Pal, VBS Purvanchal University, Jaunpur, India  
Associate Prof. Suneet Chaudhary, Dehradun Institute of Technology, India  
Associate Prof. Dr. Manuj Darbari, BBD University, India  
Ms. Prema Selvaraj, K.S.R College of Arts and Science, India  
Assist. Prof. Ms.S.Sasikala, KSR College of Arts & Science, India  
Mr. Sukhvinder Singh Deora, NC Institute of Computer Sciences, India  
Dr. Abhay Bansal, Amity School of Engineering & Technology, India  
Ms. Sumita Mishra, Amity School of Engineering and Technology, India  
Professor S. Viswanadha Raju, JNT University Hyderabad, India

Mr. Asghar Shahrzad Khashandarag, Islamic Azad University Tabriz Branch, India  
Mr. Manoj Sharma, Panipat Institute of Engg. & Technology, India  
Mr. Shakeel Ahmed, King Faisal University, Saudi Arabia  
Dr. Mohamed Ali Mahjoub, Institute of Engineer of Monastir, Tunisia  
Mr. Adri Jovin J.J., SriGuru Institute of Technology, India  
Dr. Sukumar Senthilkumar, Universiti Sains Malaysia, Malaysia  
Mr. Rakesh Bharati, Dehradun Institute of Technology Dehradun, India  
Mr. Shervan Fekri Ershad, Shiraz International University, Iran  
Mr. Md. Safiqul Islam, Daffodil International University, Bangladesh  
Mr. Mahmudul Hasan, Daffodil International University, Bangladesh  
Prof. Mandakini Tayade, UIT, RGTU, Bhopal, India  
Ms. Sarla More, UIT, RGTU, Bhopal, India  
Mr. Tushar Hrishikesh Jaware, R.C. Patel Institute of Technology, Shirpur, India  
Ms. C. Divya, Dr G R Damodaran College of Science, Coimbatore, India  
Mr. Fahimuddin Shaik, Annamacharya Institute of Technology & Sciences, India  
Dr. M. N. Giri Prasad, JNTUCE,Pulivendula, A.P., India  
Assist. Prof. Chintan M Bhatt, Charotar University of Science And Technology, India  
Prof. Sahista Machchhar, Marwadi Education Foundation's Group of institutions, India  
Assist. Prof. Navnish Goel, S. D. College Of Enginnering & Technology, India  
Mr. Khaja Kamaluddin, Sirt University, Sirt, Libya  
Mr. Mohammad Zaidul Karim, Daffodil International, Bangladesh  
Mr. M. Vijayakumar, KSR College of Engineering, Tiruchengode, India  
Mr. S. A. Ahsan Rajon, Khulna University, Bangladesh  
Dr. Muhammad Mohsin Nazir, LCW University Lahore, Pakistan  
Mr. Mohammad Asadul Hoque, University of Alabama, USA  
Mr. P.V.Sarathchand, Indur Institute of Engineering and Technology, India  
Mr. Durgesh Samadhiya, Chung Hua University, Taiwan  
Dr Venu Kuthadi, University of Johannesburg, Johannesburg, RSA  
Dr. (Er) Jasvir Singh, Guru Nanak Dev University, Amritsar, Punjab, India  
Mr. Jasmin Cosic, Min. of the Interior of Una-sana canton, B&H, Bosnia and Herzegovina  
Dr S. Rajalakshmi, Botho College, South Africa  
Dr. Mohamed Sarrab, De Montfort University, UK  
Mr. Basappa B. Kodada, Canara Engineering College, India  
Assist. Prof. K. Ramana, Annamacharya Institute of Technology and Sciences, India  
Dr. Ashu Gupta, Apeejay Institute of Management, Jalandhar, India  
Assist. Prof. Shaik Rasool, Shadan College of Engineering & Technology, India  
Assist. Prof. K. Suresh, Annamacharya Institute of Tech & Sci. Rajampet, AP, India  
Dr . G. Singaravel, K.S.R. College of Engineering, India  
Dr B. G. Geetha, K.S.R. College of Engineering, India  
Assist. Prof. Kavita Choudhary, ITM University, Gurgaon  
Dr. Mehrdad Jalali, Azad University, Mashhad, Iran  
Megha Goel, Shamli Institute of Engineering and Technology, Shamli, India

Mr. Chi-Hua Chen, Institute of Information Management, National Chiao-Tung University, Taiwan (R.O.C.)  
Assoc. Prof. A. Rajendran, RVS College of Engineering and Technology, India  
Assist. Prof. S. Jaganathan, RVS College of Engineering and Technology, India  
Assoc. Prof. A S N Chakravarthy, Sri Aditya Engineering College, India  
Assist. Prof. Deepshikha Patel, Technocrat Institute of Technology, India  
Assist. Prof. Maram Balajee, GMRIT, India  
Assist. Prof. Monika Bhatnagar, TIT, India  
Prof. Gaurang Panchal, Charotar University of Science & Technology, India  
Prof. Anand K. Tripathi, Computer Society of India  
Prof. Jyoti Chaudhary, High Performance Computing Research Lab, India  
Assist. Prof. Supriya Raheja, ITM University, India  
Dr. Pankaj Gupta, Microsoft Corporation, U.S.A.  
Assist. Prof. Panchamukesh Chandaka, Hyderabad Institute of Tech. & Management, India  
Prof. Mohan H.S, SJB Institute Of Technology, India  
Mr. Hossein Malekinezhad, Islamic Azad University, Iran  
Mr. Zatin Gupta, Universti Malaysia, Malaysia  
Assist. Prof. Amit Chauhan, Phonics Group of Institutions, India  
Assist. Prof. Ajal A. J., METS School Of Engineering, India  
Mrs. Omowunmi Omobola Adeyemo, University of Ibadan, Nigeria  
Dr. Bharat Bhushan Agarwal, I.F.T.M. University, India  
Md. Nazrul Islam, University of Western Ontario, Canada  
Tushar Kanti, L.N.C.T, Bhopal, India  
Er. Aumreesh Kumar Saxena, SIRT's College Bhopal, India  
Mr. Mohammad Monirul Islam, Daffodil International University, Bangladesh  
Dr. Kashif Nisar, University Utara Malaysia, Malaysia  
Dr. Wei Zheng, Rutgers Univ/ A10 Networks, USA  
Associate Prof. Rituraj Jain, Vyas Institute of Engg & Tech, Jodhpur – Rajasthan  
Assist. Prof. Apoorvi Sood, I.T.M. University, India  
Dr. Kayhan Zrar Ghafoor, University Technology Malaysia, Malaysia  
Mr. Swapnil Soner, Truba Institute College of Engineering & Technology, Indore, India  
Ms. Yogita Gigras, I.T.M. University, India  
Associate Prof. Neelima Sadineni, Pydha Engineering College, India Pydha Engineering College  
Assist. Prof. K. Deepika Rani, HITAM, Hyderabad  
Ms. Shikha Maheshwari, Jaipur Engineering College & Research Centre, India  
Prof. Dr V S Giridhar Akula, Avanthi's Scientific Tech. & Research Academy, Hyderabad  
Prof. Dr.S.Saravanan, Muthayammal Engineering College, India  
Mr. Mehdi Golsorkhatabar Amiri, Islamic Azad University, Iran  
Prof. Amit Sadanand Savyanavar, MITCOE, Pune, India  
Assist. Prof. P.Oliver Jayaprakash, Anna University, Chennai  
Assist. Prof. Ms. Sujata, ITM University, Gurgaon, India  
Dr. Asoke Nath, St. Xavier's College, India  
Mr. Masoud Rafighi, Islamic Azad University, Iran

Assist. Prof. RamBabu Pemula, NIMRA College of Engineering & Technology, India  
Assist. Prof. Ms Rita Chhikara, ITM University, Gurgaon, India  
Mr. Sandeep Maan, Government Post Graduate College, India  
Prof. Dr. S. Muralidharan, Mepco Schlenk Engineering College, India  
Associate Prof. T.V.Sai Krishna, QIS College of Engineering and Technology, India  
Mr. R. Balu, Bharathiar University, Coimbatore, India  
Assist. Prof. Shekhar. R, Dr.SM College of Engineering, India  
Prof. P. Senthilkumar, Vivekanandha Institute of Engineering And Technology For Woman, India  
Mr. M. Kamarajan, PSNA College of Engineering & Technology, India  
Dr. Angajala Srinivasa Rao, Jawaharlal Nehru Technical University, India  
Assist. Prof. C. Venkatesh, A.I.T.S, Rajampet, India  
Mr. Afshin Rezakhani Roozbahani, Ayatollah Boroujerdi University, Iran  
Mr. Laxmi chand, SCTL, Noida, India  
Dr. Dr. Abdul Hannan, Vivekanand College, Aurangabad  
Prof. Mahesh Panchal, KITRC, Gujarat  
Dr. A. Subramani, K.S.R. College of Engineering, Tiruchengode  
Assist. Prof. Prakash M, Rajalakshmi Engineering College, Chennai, India  
Assist. Prof. Akhilesh K Sharma, Sir Padampat Singhania University, India  
Ms. Varsha Sahni, Guru Nanak Dev Engineering College, Ludhiana, India  
Associate Prof. Trilochan Rout, NM Institute Of Engineering And Technology, India  
Mr. Srikanta Kumar Mohapatra, NMIET, Orissa, India  
Mr. Waqas Haider Bangyal, Iqra University Islamabad, Pakistan  
Dr. S. Vijayaragavan, Christ College of Engineering and Technology, Pondicherry, India  
Prof. Elboukhari Mohamed, University Mohammed First, Oujda, Morocco  
Dr. Muhammad Asif Khan, King Faisal University, Saudi Arabia  
Dr. Nagy Ramadan Darwish Omran, Cairo University, Egypt.  
Assistant Prof. Anand Nayyar, KCL Institute of Management and Technology, India  
Mr. G. Premsankar, Ericsson, India  
Assist. Prof. T. Hemalatha, VELS University, India  
Prof. Tejaswini Apte, University of Pune, India  
Dr. Edmund Ng Giap Weng, Universiti Malaysia Sarawak, Malaysia  
Mr. Mahdi Nouri, Iran University of Science and Technology, Iran  
Associate Prof. S. Asif Hussain, Annamacharya Institute of technology & Sciences, India  
Mrs. Kavita Pabreja, Maharaja Surajmal Institute (an affiliate of GGSIP University), India  
Mr. Vorugunti Chandra Sekhar, DA-IICT, India  
Mr. Muhammad Najmi Ahmad Zabidi, Universiti Teknologi Malaysia, Malaysia  
Dr. Aderemi A. Atayero, Covenant University, Nigeria  
Assist. Prof. Osama Sohaib, Balochistan University of Information Technology, Pakistan  
Assist. Prof. K. Suresh, Annamacharya Institute of Technology and Sciences, India  
Mr. Hassen Mohammed Abdullh Alsafi, International Islamic University Malaysia (IIUM) Malaysia  
Mr. Robail Yasrab, Virtual University of Pakistan, Pakistan  
Mr. R. Balu, Bharathiar University, Coimbatore, India

Prof. Anand Nayyar, KCL Institute of Management and Technology, Jalandhar  
Assoc. Prof. Vivek S Deshpande, MIT College of Engineering, India  
Prof. K. Saravanan, Anna university Coimbatore, India  
Dr. Ravendra Singh, MJP Rohilkhand University, Bareilly, India  
Mr. V. Mathivanan, IBRA College of Technology, Sultanate of OMAN  
Assoc. Prof. S. Asif Hussain, AITS, India  
Assist. Prof. C. Venkatesh, AITS, India  
Mr. Sami Ulhaq, SZABIST Islamabad, Pakistan  
Dr. B. Justus Rabi, Institute of Science & Technology, India  
Mr. Anuj Kumar Yadav, Dehradun Institute of technology, India  
Mr. Alejandro Mosquera, University of Alicante, Spain  
Assist. Prof. Arjun Singh, Sir Padampat Singhania University (SPSU), Udaipur, India  
Dr. Smriti Agrawal, JB Institute of Engineering and Technology, Hyderabad  
Assist. Prof. Swathi Sambangi, Visakha Institute of Engineering and Technology, India  
Ms. Prabhjot Kaur, Guru Gobind Singh Indraprastha University, India  
Mrs. Samaher AL-Hothali, Yanbu University College, Saudi Arabia  
Prof. Rajneeshkaur Bedi, MIT College of Engineering, Pune, India  
Mr. Hassen Mohammed Abdulllah Alsafi, International Islamic University Malaysia (IIUM)  
Dr. Wei Zhang, Amazon.com, Seattle, WA, USA  
Mr. B. Santhosh Kumar, C S I College of Engineering, Tamil Nadu  
Dr. K. Reji Kumar, , N S S College, Pandalam, India  
Assoc. Prof. K. Seshadri Sastry, EILM University, India  
Mr. Kai Pan, UNC Charlotte, USA  
Mr. Ruikar Sachin, SGGSIET, India  
Prof. (Dr.) Vinodani Katiyar, Sri Ramswaroop Memorial University, India  
Assoc. Prof., M. Giri, Sreenivasa Institute of Technology and Management Studies, India  
Assoc. Prof. Labib Francis Gergis, Misr Academy for Engineering and Technology ( MET ), Egypt  
Assist. Prof. Amanpreet Kaur, ITM University, India  
Assist. Prof. Anand Singh Rajawat, Shri Vaishnav Institute of Technology & Science, Indore  
Mrs. Hadeel Saleh Haj Aliwi, Universiti Sains Malaysia (USM), Malaysia  
Dr. Abhay Bansal, Amity University, India  
Dr. Mohammad A. Mezher, Fahad Bin Sultan University, KSA  
Assist. Prof. Nidhi Arora, M.C.A. Institute, India  
Prof. Dr. P. Suresh, Karpagam College of Engineering, Coimbatore, India  
Dr. Kannan Balasubramanian, Mepco Schlenk Engineering College, India  
Dr. S. Sankara Gomathi, Panimalar Engineering college, India  
Prof. Anil kumar Suthar, Gujarat Technological University, L.C. Institute of Technology, India  
Assist. Prof. R. Hubert Rajan, NOORUL ISLAM UNIVERSITY, India  
Assist. Prof. Dr. Jyoti Mahajan, College of Engineering & Technology  
Assist. Prof. Homam Reda El-Taj, College of Network Engineering, Saudi Arabia & Malaysia  
Mr. Bijan Paul, Shahjalal University of Science & Technology, Bangladesh  
Assoc. Prof. Dr. Ch V Phani Krishna, KL University, India

Dr. Vishal Bhatnagar, Ambedkar Institute of Advanced Communication Technologies & Research, India  
Dr. Lamri LAOUAMER, Al Qassim University, Dept. Info. Systems & European University of Brittany, Dept.  
Computer Science, UBO, Brest, France  
Prof. Ashish Babanrao Sasankar, G.H.Raisoni Institute Of Information Technology, India  
Prof. Pawan Kumar Goel, Shamli Institute of Engineering and Technology, India  
Mr. Ram Kumar Singh, S.V Subharti University, India  
Assistant Prof. Sunish Kumar O S, Amaljyothi College of Engineering, India  
Dr Sanjay Bhargava, Banasthali University, India  
Mr. Pankaj S. Kulkarni, AVEW's Shatabdi Institute of Technology, India  
Mr. Roohollah Etemadi, Islamic Azad University, Iran  
Mr. Oloruntoyin Sefiu Taiwo, Emmanuel Alayande College Of Education, Nigeria  
Mr. Sumit Goyal, National Dairy Research Institute, India  
Mr Jaswinder Singh Dilawari, Geeta Engineering College, India  
Prof. Raghuraj Singh, Harcourt Butler Technological Institute, Kanpur  
Dr. S.K. Mahendran, Anna University, Chennai, India  
Dr. Amit Wason, Hindustan Institute of Technology & Management, Punjab  
Dr. Ashu Gupta, Apeejay Institute of Management, India  
Assist. Prof. D. Asir Antony Gnana Singh, M.I.E.T Engineering College, India  
Mrs Mina Farmanbar, Eastern Mediterranean University, Famagusta, North Cyprus  
Mr. Maram Balajee, GMR Institute of Technology, India  
Mr. Moiz S. Ansari, Isra University, Hyderabad, Pakistan  
Mr. Adebayo, Olawale Surajudeen, Federal University of Technology Minna, Nigeria  
Mr. Jasvir Singh, University College Of Engg., India

# CALL FOR PAPERS

## International Journal of Computer Science and Information Security

IJCSIS 2013

ISSN: 1947-5500

<http://sites.google.com/site/ijcsis/>

International Journal Computer Science and Information Security, IJCSIS, is the premier scholarly venue in the areas of computer science and security issues. IJCSIS 2011 will provide a high profile, leading edge platform for researchers and engineers alike to publish state-of-the-art research in the respective fields of information technology and communication security. The journal will feature a diverse mixture of publication articles including core and applied computer science related topics.

Authors are solicited to contribute to the special issue by submitting articles that illustrate research results, projects, surveying works and industrial experiences that describe significant advances in the following areas, but are not limited to. Submissions may span a broad range of topics, e.g.:

### *Track A: Security*

Access control, Anonymity, Audit and audit reduction & Authentication and authorization, Applied cryptography, Cryptanalysis, Digital Signatures, Biometric security, Boundary control devices, Certification and accreditation, Cross-layer design for security, Security & Network Management, Data and system integrity, Database security, Defensive information warfare, Denial of service protection, Intrusion Detection, Anti-malware, Distributed systems security, Electronic commerce, E-mail security, Spam, Phishing, E-mail fraud, Virus, worms, Trojan Protection, Grid security, Information hiding and watermarking & Information survivability, Insider threat protection, Integrity  
Intellectual property protection, Internet/Intranet Security, Key management and key recovery, Language-based security, Mobile and wireless security, Mobile, Ad Hoc and Sensor Network Security, Monitoring and surveillance, Multimedia security ,Operating system security, Peer-to-peer security, Performance Evaluations of Protocols & Security Application, Privacy and data protection, Product evaluation criteria and compliance, Risk evaluation and security certification, Risk/vulnerability assessment, Security & Network Management, Security Models & protocols, Security threats & countermeasures (DDoS, MiM, Session Hijacking, Replay attack etc.), Trusted computing, Ubiquitous Computing Security, Virtualization security, VoIP security, Web 2.0 security, Submission Procedures, Active Defense Systems, Adaptive Defense Systems, Benchmark, Analysis and Evaluation of Security Systems, Distributed Access Control and Trust Management, Distributed Attack Systems and Mechanisms, Distributed Intrusion Detection/Prevention Systems, Denial-of-Service Attacks and Countermeasures, High Performance Security Systems, Identity Management and Authentication, Implementation, Deployment and Management of Security Systems, Intelligent Defense Systems, Internet and Network Forensics, Large-scale Attacks and Defense, RFID Security and Privacy, Security Architectures in Distributed Network Systems, Security for Critical Infrastructures, Security for P2P systems and Grid Systems, Security in E-Commerce, Security and Privacy in Wireless Networks, Secure Mobile Agents and Mobile Code, Security Protocols, Security Simulation and Tools, Security Theory and Tools, Standards and Assurance Methods, Trusted Computing, Viruses, Worms, and Other Malicious Code, World Wide Web Security, Novel and emerging secure architecture, Study of attack strategies, attack modeling, Case studies and analysis of actual attacks, Continuity of Operations during an attack, Key management, Trust management, Intrusion detection techniques, Intrusion response, alarm management, and correlation analysis, Study of tradeoffs between security and system performance, Intrusion tolerance systems, Secure protocols, Security in wireless networks (e.g. mesh networks, sensor networks, etc.), Cryptography and Secure Communications, Computer Forensics, Recovery and Healing, Security Visualization, Formal Methods in Security, Principles for Designing a Secure Computing System, Autonomic Security, Internet Security, Security in Health Care Systems, Security Solutions Using Reconfigurable Computing, Adaptive and Intelligent Defense Systems, Authentication and Access control, Denial of service attacks and countermeasures, Identity, Route and

Location Anonymity schemes, Intrusion detection and prevention techniques, Cryptography, encryption algorithms and Key management schemes, Secure routing schemes, Secure neighbor discovery and localization, Trust establishment and maintenance, Confidentiality and data integrity, Security architectures, deployments and solutions, Emerging threats to cloud-based services, Security model for new services, Cloud-aware web service security, Information hiding in Cloud Computing, Securing distributed data storage in cloud, Security, privacy and trust in mobile computing systems and applications, **Middleware security & Security features:** middleware software is an asset on its own and has to be protected, interaction between security-specific and other middleware features, e.g., context-awareness, **Middleware-level security monitoring and measurement:** metrics and mechanisms for quantification and evaluation of security enforced by the middleware, **Security co-design:** trade-off and co-design between application-based and middleware-based security, **Policy-based management:** innovative support for policy-based definition and enforcement of security concerns, **Identification and authentication mechanisms:** Means to capture application specific constraints in defining and enforcing access control rules, **Middleware-oriented security patterns:** identification of patterns for sound, reusable security, **Security in aspect-based middleware:** mechanisms for isolating and enforcing security aspects, **Security in agent-based platforms:** protection for mobile code and platforms, Smart Devices: Biometrics, National ID cards, Embedded Systems Security and TPMs, RFID Systems Security, Smart Card Security, Pervasive Systems: Digital Rights Management (DRM) in pervasive environments, Intrusion Detection and Information Filtering, Localization Systems Security (Tracking of People and Goods), Mobile Commerce Security, Privacy Enhancing Technologies, Security Protocols (for Identification and Authentication, Confidentiality and Privacy, and Integrity), Ubiquitous Networks: Ad Hoc Networks Security, Delay-Tolerant Network Security, Domestic Network Security, Peer-to-Peer Networks Security, Security Issues in Mobile and Ubiquitous Networks, Security of GSM/GPRS/UMTS Systems, Sensor Networks Security, Vehicular Network Security, Wireless Communication Security: Bluetooth, NFC, WiFi, WiMAX, WiMedia, others

This Track will emphasize the design, implementation, management and applications of computer communications, networks and services. Topics of mostly theoretical nature are also welcome, provided there is clear practical potential in applying the results of such work.

### ***Track B: Computer Science***

Broadband wireless technologies: LTE, WiMAX, WiRAN, HSDPA, HSUPA, Resource allocation and interference management, Quality of service and scheduling methods, Capacity planning and dimensioning, Cross-layer design and Physical layer based issue, Interworking architecture and interoperability, Relay assisted and cooperative communications, Location and provisioning and mobility management, Call admission and flow/congestion control, Performance optimization, Channel capacity modeling and analysis, Middleware Issues: Event-based, publish/subscribe, and message-oriented middleware, Reconfigurable, adaptable, and reflective middleware approaches, Middleware solutions for reliability, fault tolerance, and quality-of-service, Scalability of middleware, Context-aware middleware, Autonomic and self-managing middleware, Evaluation techniques for middleware solutions, Formal methods and tools for designing, verifying, and evaluating, middleware, Software engineering techniques for middleware, Service oriented middleware, Agent-based middleware, Security middleware, Network Applications: Network-based automation, Cloud applications, Ubiquitous and pervasive applications, Collaborative applications, RFID and sensor network applications, Mobile applications, Smart home applications, Infrastructure monitoring and control applications, Remote health monitoring, GPS and location-based applications, Networked vehicles applications, Alert applications, Embedded Computer System, Advanced Control Systems, and Intelligent Control : Advanced control and measurement, computer and microprocessor-based control, signal processing, estimation and identification techniques, application specific IC's, nonlinear and adaptive control, optimal and robot control, intelligent control, evolutionary computing, and intelligent systems, instrumentation subject to critical conditions, automotive, marine and aero-space control and all other control applications, Intelligent Control System, Wiring/Wireless Sensor, Signal Control System. Sensors, Actuators and Systems Integration : Intelligent sensors and actuators, multisensor fusion, sensor array and multi-channel processing, micro/nano technology, microsensors and microactuators, instrumentation electronics, MEMS and system integration, wireless sensor, Network Sensor, Hybrid



Sensor, Distributed Sensor Networks. Signal and Image Processing : Digital signal processing theory, methods, DSP implementation, speech processing, image and multidimensional signal processing, Image analysis and processing, Image and Multimedia applications, Real-time multimedia signal processing, Computer vision, Emerging signal processing areas, Remote Sensing, Signal processing in education. Industrial Informatics: Industrial applications of neural networks, fuzzy algorithms, Neuro-Fuzzy application, bioInformatics, real-time computer control, real-time information systems, human-machine interfaces, CAD/CAM/CAT/CIM, virtual reality, industrial communications, flexible manufacturing systems, industrial automated process, Data Storage Management, Harddisk control, Supply Chain Management, Logistics applications, Power plant automation, Drives automation. Information Technology, Management of Information System : Management information systems, Information Management, Nursing information management, Information System, Information Technology and their application, Data retrieval, Data Base Management, Decision analysis methods, Information processing, Operations research, E-Business, E-Commerce, E-Government, Computer Business, Security and risk management, Medical imaging, Biotechnology, Bio-Medicine, Computer-based information systems in health care, Changing Access to Patient Information, Healthcare Management Information Technology. Communication/Computer Network, Transportation Application : On-board diagnostics, Active safety systems, Communication systems, Wireless technology, Communication application, Navigation and Guidance, Vision-based applications, Speech interface, Sensor fusion, Networking theory and technologies, Transportation information, Autonomous vehicle, Vehicle application of affective computing, Advance Computing technology and their application : Broadband and intelligent networks, Data Mining, Data fusion, Computational intelligence, Information and data security, Information indexing and retrieval, Information processing, Information systems and applications, Internet applications and performances, Knowledge based systems, Knowledge management, Software Engineering, Decision making, Mobile networks and services, Network management and services, Neural Network, Fuzzy logics, Neuro-Fuzzy, Expert approaches, Innovation Technology and Management : Innovation and product development, Emerging advances in business and its applications, Creativity in Internet management and retailing, B2B and B2C management, Electronic transceiver device for Retail Marketing Industries, Facilities planning and management, Innovative pervasive computing applications, Programming paradigms for pervasive systems, Software evolution and maintenance in pervasive systems, Middleware services and agent technologies, Adaptive, autonomic and context-aware computing, Mobile/Wireless computing systems and services in pervasive computing, Energy-efficient and green pervasive computing, Communication architectures for pervasive computing, Ad hoc networks for pervasive communications, Pervasive opportunistic communications and applications, Enabling technologies for pervasive systems (e.g., wireless BAN, PAN), Positioning and tracking technologies, Sensors and RFID in pervasive systems, Multimodal sensing and context for pervasive applications, Pervasive sensing, perception and semantic interpretation, Smart devices and intelligent environments, Trust, security and privacy issues in pervasive systems, User interfaces and interaction models, Virtual immersive communications, Wearable computers, Standards and interfaces for pervasive computing environments, Social and economic models for pervasive systems, Active and Programmable Networks, Ad Hoc & Sensor Network, Congestion and/or Flow Control, Content Distribution, Grid Networking, High-speed Network Architectures, Internet Services and Applications, Optical Networks, Mobile and Wireless Networks, Network Modeling and Simulation, Multicast, Multimedia Communications, Network Control and Management, Network Protocols, Network Performance, Network Measurement, Peer to Peer and Overlay Networks, Quality of Service and Quality of Experience, Ubiquitous Networks, Crosscutting Themes – Internet Technologies, Infrastructure, Services and Applications; Open Source Tools, Open Models and Architectures; Security, Privacy and Trust; Navigation Systems, Location Based Services; Social Networks and Online Communities; ICT Convergence, Digital Economy and Digital Divide, Neural Networks, Pattern Recognition, Computer Vision, Advanced Computing Architectures and New Programming Models, Visualization and Virtual Reality as Applied to Computational Science, Computer Architecture and Embedded Systems, Technology in Education, Theoretical Computer Science, Computing Ethics, Computing Practices & Applications

Authors are invited to submit papers through e-mail [ijcsiseditor@gmail.com](mailto:ijcsiseditor@gmail.com). Submissions must be original and should not have been published previously or be under consideration for publication while being evaluated by IJCSIS. Before submission authors should carefully read over the journal's Author Guidelines, which are located at <http://sites.google.com/site/ijcsis/authors-notes> .



**© IJCSIS PUBLICATION 2012**  
**ISSN 1947 5500**  
**<http://sites.google.com/site/ijcsis/>**