

## **DESIGN AND CONSTRUCTION OF A MICROCONTROLLER BASED SINGLE AXIS SOLAR TRACKER.**

S. Zubair<sup>1</sup>, A. Suleiman<sup>2</sup>, H. T. Abdulazze<sup>2</sup>, B. A. Salihu<sup>1</sup>

<sup>1</sup>Department of Communication Engineering Federal university of Technology Minna

<sup>2</sup>Department of Cyber Security Federal university of Technology Minna

### ARTICLE INFO

*Article history:*

Accepted:

Available online: 10 August 2011

*Keywords:*

*Tracking,  
Microcontroller,  
photocells,  
drivers,  
single axis.*

### ABSTRACT

Solar energy is rapidly gaining popularity as an important means of expanding renewable energy resources. As such, it is vital that those in engineering fields understand the technologies associated with this area. This paper presents the design and construction of a microcontroller-based solar panel tracking system. Solar tracking allows more energy to be produced because the solar array is able to remain aligned to the sun. A working system will ultimately be demonstrated to validate the design. Problems and possible improvements will also be presented.

© 2011 woaj Ltd. All rights reserved

### 1. Introduction

Renewable energy solutions are becoming increasingly popular. Photovoltaic (solar) systems are but one

example. Maximizing power output from a solar system is desirable to increase efficiency. In order to maximize power output from the solar panels, one needs to keep the panels aligned with the sun. As such, a means of tracking the sun is required. This is a far more cost effective solution than purchasing additional solar panels. It has been estimated that the yield from solar panels can be increased by 21 percent by utilizing a single axis tracking system instead of a stationary array [1].

\* Corresponding author.

email address: [zubairman@futminna.edu.ng](mailto:zubairman@futminna.edu.ng)

2011 woaj Ltd. All rights reserved

The aims and objective of this paper is to design and implement a microcontroller based solar automatic tracking system with a working software which will always keep the solar panels aligned with the sun in order to maximize efficiency.

This paper begins with presenting a review of the sun-tracking technologies, the paper continues with specific design methodologies pertaining to photocells, stepper motors and drivers, microcontroller selection, voltage regulation, physical construction, and a software/system operation explanation. The paper concludes with a discussion of design results and future work.

## 2. Review of Sun-Tracker Technology

There are a number of works proposed by many researchers to track the sun. Kalogirou and Alata *et al.* suggested [2,3] a tracking system which can be used with single-axis solar concentrating systems, Roth *et al.* and Bakos [4,5] constructed and tested two axis tracking system. Different types of one-axis tracking systems have been applied in the literature [6–8]. Tomson [6] described mainly the performance of PV modules with daily two-position in the morning and in the afternoon. Results indicated that the seasonal energy yield was increased by 10–20% over the yield from a fixed south facing collector tilted at an optimal angle. Huang and Sun [7] has designed the solar tracking system called “one axis three position sun tracking PV module” with low concentration ratio reflector. The one-axis tracking mechanism adjusted the PV position only at three fixed angles. These are the morning, the noon and the afternoon. An experiment performed in the present study indicated that economic analysis showed that the price reduction was between 20% and 30% for the various market prices of flat plate PV modules. Abu-Khadera *et al.* [9] investigated the effects of multi-axes sun-tracking systems on the electrical generation of a flat photovoltaic system (FPVS) which was carried out to evaluate its performance under Jordanian climate. Multi-axes (N–S, E–W, vertical) electromechanical sun-tracking system was designed and constructed. The measured variables were compared with that at fixed axis. It was found that there was an overall increase of about 30–45% in the output power for the north–south axes (N–S)-tracking system compared to the fixed PV system. Also, it was found that the N–S axes sun tracking was the optimum. Bakos [5] performed to investigate the effect of using a continuous operation wo-axes tracking on the solar energy collected. The collected energy was measured and compared with that on a fixed surface tilted at 41 towards the south. The results showed that the measured collected solar energy on the moving surface was considerably larger (up to 46.46%) compared with the fixed

surface. Abdallah [10] implemented four electromechanical sun-tracking systems, two axes, one axis vertical, one axis east–west and one axis north–south, were designed and constructed for the purpose of investigating the effect of tracking on the current, the voltage and the power, according to the different loads. The results indicated that increases of electrical power gains up to 43.87% for the two axes, 37.53% for the east–west, 34.43% for the vertical and 15.69% for the north–south tracking, as compared with the fixed surface inclined 32 to the south in Amman. There are also many different controllers such as PC, PLC, PLA, microcontroller and electro-optically to implement the control techniques [11– 16]. In addition to this Georgiev *et al.* [17] expressed that modern measuring and registering system for actual data more easily than conventional systems [17].

When the literatures are analyzed, the parameters such as the installation, the mechanism, the cost, the efficiency, the design and the maintenance have been given as important features depend on tracking methods as given in Table 1.

Table 1: Comparison of Solar Systems.

Parameters	Fixed	One-axis	Two axes	Developed system
Installation	Easy	Easy	Difficult	Easy
Mechanism	No mechanism	Simple	Complicated	Simple
Cost	Cheap	Moderate	Expensive	Moderate
Efficiency	Reference efficiency	10–35% > fixed system	25–45% > fixed system	10–45% > fixed system
Design	Simple	Moderate	Complicated	Simple
Maintenance	Less	Moderate	More	Less

The design presented is splendid for outpost systems that hardly require any monitoring and needs moderate maintenance to improve their efficiency.

## 3. Materials and Methods

The solar elevation tracker is a closed loop control system that covers both fields of electronics and mechanical engineering. This system is used to position solar panels to positions of the sun so as to achieve higher efficiency of power generation. The components of the electronic system consist of a Microcontroller logic circuitry, a Comparator, a DC motor, a relay, cadmium Sulphide photoconductive cells (photo sensors), a Transformer. These components are grouped into the following units and illustrated in the block diagram below in figure 1:

1. Power Unit.
2. Comparator Unit.
3. Control Unit.
4. Relay Unit.

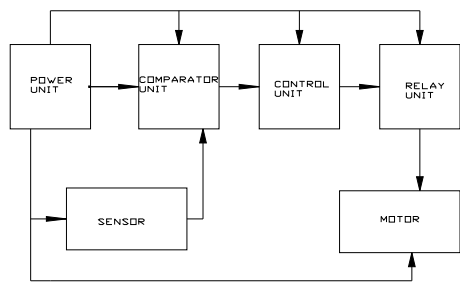

Fig. 1 Block diagram of the system

**3.1 Power unit:**

This consists of a 220-12V 500mA Step down Transformer with a rectified output of 12V. This rectified output is smoothened by a 2200µF capacitor, the 7805 voltage regulator converts the 12V rectified filtered voltage to a voltage level of +5V which is used by the AT89S51 microcontroller and the comparator (LM324). Circuit is presented in figure 2.

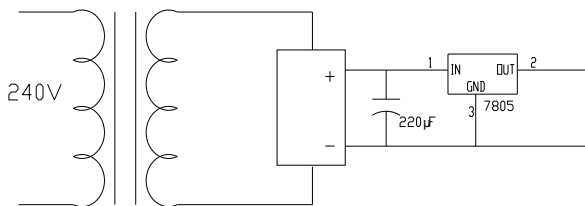

Fig. 2: Power unit circuit

**Calculations involved:**

$$\text{peak value of the secondary} = \sqrt{2} \times V_{rms}$$

(1)

$$12 \times \sqrt{2} = 16.9 \text{volts}$$

$$Q = It = Cdv$$

(2)

$$C = \frac{It}{dv}$$

(3)

$$t = \frac{1}{2f} = \frac{1}{100} \text{ since } f = 50\text{Hz}$$

but dv = 15% of peak voltage

$$dv = \frac{15 \times 16.9}{100} = 2.55 \text{volts}$$

$$C = \frac{0.5 \times 0.01}{2.55} = 1960 \mu F$$

$$C = 2200 \mu F$$

**3.2 Comparator unit:**

This is achieved by using the operational amplifier LM324. This consists of four independent, high gain, internally compensated operational amplifiers which were designed specifically to operate from a single power supply over a wide range of voltages. Operation from split power supplies is also possible and low power supply current drain is independent of the magnitude of the power supply voltage.

**Operation of a comparator:**

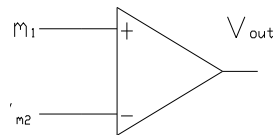

Fig. 3 circuit symbol of a comparator.

If the voltage Vm1 is greater than Vm2 the Vout would be high. If Vm1 is less than Vm2 then Vout would be low. However, since sunlight is what we want to monitor then an LDR (Light Dependent Resistor) is used to sense the intensity of the sun.

**3.2.1 Light sensor:**

Light sensors are among the common sensor type. The simplest optical sensor is the photo resistor which may be a cadmium sulphide (CdS) type or a Gallium Arsenide (GaAs) type. The next step in complexity is the photodiode followed by the phototransistor. The sun tracker uses cadmium sulphide (CdS) photocell for sensing. This is the least expensive and least complex type of light sensor. The LDR is a resistor whose resistance decreases with increasing light intensity. It can also be referenced to as a photo conductor. A photo resistor is made of high resistance semiconductor. If light falling on the device is of high enough frequency, photons absorbed by the semiconductor give bound electrons enough energy to jump to the conduction band. The resulting free electron and its hole partner conducts electricity, thereby lowering resistance. The reverse is the case when darkness falls on the LDR, for this will increase its resistance. This characteristic of the LDR is used to vary the input voltage into the comparator as the sun moves over it.

### 3.2.2 Creating varying voltage using an LDR:

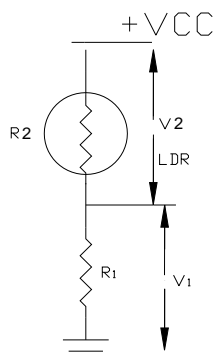

Fig. 4: How LDRs are connected in the circuit

The LDR is connected in series with a resistor (Fig. 4); a voltage divider is thus formed, which will split the voltage Vcc into two. As darkness sets in, the resistance of the LDR increases. Following the common formulae  $V=IR$ . If R increases when I is constant, then V is increased. Therefore V2 increases while V1 reduces obeying the Kirchoff voltage law which state

$$V1 = \frac{R1}{R1+R2} \times Vcc \tag{4}$$

$$V2 = \frac{R2}{R1+R2} \times Vcc \tag{5}$$

### 3.2.3 Comparator circuit:

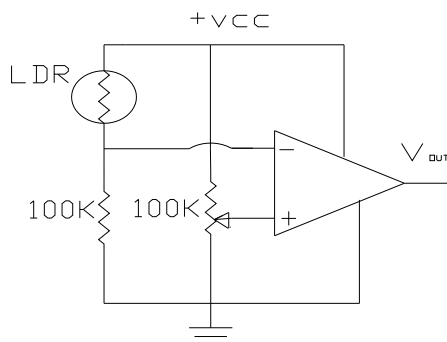

Fig. 5: The comparator circuit.

Initially the voltage at the non inverting input is set lower than that of the inverting input. As darkness increases, the voltage at the inverting input begins to drop until it gets below that of the non-inverting input. At this point, the output of the comparator is changed from low to high. We achieve this with the circuit in Fig. 5.

### 3.2.4 How this is used to accomplish the tracking:

Three of the comparators are used in the format as

specified above. They are used for finding the rays of the sun; the third is placed behind the platform as shown below

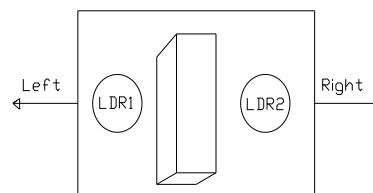

Fig. 6: Diagram of the LDRs on the platform

Both LDR, as shown in figure 6, are placed on a flat platform, a barrier demarcates them from each other. The arrows signify the direction of rotation of the solar finder. If the sun is at normal (i.e. when both LDR sees light), the output of the comparator is expected to be low, as a result the control unit which would be discussed later would not perform any operation. If the barrier cast its shadow on LDR1 as the sun moves to the right, the system would rotate to the right and will continue to do so until both LDR sees light again. When the sun sets both LDR will see darkness and the system will not rotate at all, it will remain in that position till the next day.

When the sun rises, the last LDR placed underneath the platform senses the sun's light which activates the rotation of the system back to the left (Eastward), this movement will continue until both LDR on top of the platform senses light again.

### 3.3 Control unit:

This consists of a microcontroller which functions with a crystal oscillator, reset capacitor and the enable pin (Pin 31) connected to Vcc as shown in figure 7.

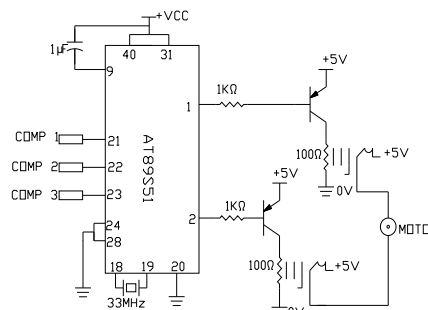

Fig.7. Circuit diagram of the control and relay unit

Since the project’s focus is on embedded software control, the microcontroller is the heart of the system. The microcontroller selected for the project had to be able to convert the analog photocell voltage into digital values and also provide output channels for motor rotation. The AT89S51 was selected because it meets these requirements. A 33MHz was used in conjunction with the AT89S51 to provide the necessary clock input. This speed is sufficient with the system.

**3.2.3.1 Software and system control unit description:**

Assembly language was utilized for the project. It was more than accurate to satisfy design objectives while enhancing the level of understanding of the language.

The program is designed to check the logic level of the three input pins (i.e. p2.0, p2.1 and p2.2), and determine which output pin (p1.0, p1.1), will be activated to energize the relays to drive the motor either east or west. If the logic level at pin p2.0 is high(when the sun is moving westward), and the other input pins low, the logic level at p1.0 is set high while that at p1.1 is set low, this will activate the system to move westward. If the logic level at pin p2.1 is high and the other input pins low, p1.1 is set high while p1.0 is set low, this moves the system eastward. The third input pin is used to return the system to its initial position (eastward) prior to the movement of the system; this happens if the p2.2 is low and other input pins high. Furthermore, the software is designed that no action is taken if all the input pins are at logic 0 or input pins p2.0 and p2.1 are at logic 1. The program flow chart is shown in figure 8, while the program code is provided in the appendix.

**3.4 Relay unit:**

A relay is an adaptation of an electromagnet. It consist of a coil of wire surrounding a soft iron core, an iron yoke, which provides a low reluctance path for magnetic flux, a movable iron armature and a set of contacts. The armature is hinged to the yoke and mechanically linked to a moving contact. It is held in place by a spring so that when the relay is de-energized there is an air gap in the magnetic circuit. In this condition one of the contact is closed and the other open.

When an electric current is passed through the coil, the resulting magnetic field attracts the armature and the consequent movement of the movable contact either makes or breaks a connection with a fixed contact. If the set of contact were closed when the relay was de-energized, then the movement opens the contact and breaks the connection and vice versa if the contacts were

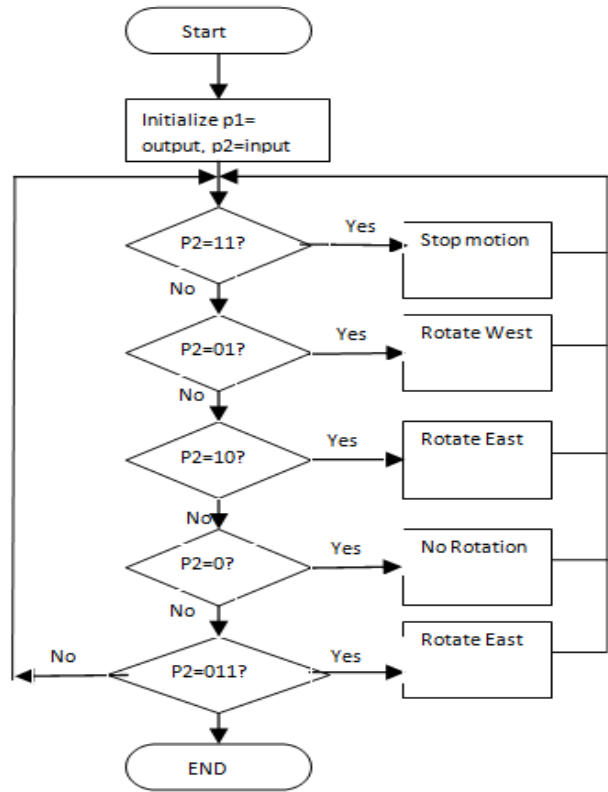

open. The make and break characteristics of the relay makes it suitable to be used as a switch.

Fig.8 program flow chat

The sun tracker uses two 6V relays in conjunction with A1015 transistors, and a biasing resistor. The transistors provide the means through which the relay is connected to ground and triggered, it completes the circuit. This connection is used to drive the motor, that is, it makes up the driver circuitry. This was shown in the diagram in the control unit earlier. The calculations:

$$V_{cc} = +5V, R_c = \text{resistance of relay} = 100\Omega$$

$$V_{cc} = I_c R_c$$

$$I_c = \frac{V_{cc}}{R_c} = \frac{5V}{100} = 0.05 \text{ Amps}$$

$$h_{fe} = \frac{I_c}{I_b} \cdot I_b = \frac{I_c}{h_{fe}} = \frac{0.05 \text{ Amps}}{12}$$

$$\text{using } h_{fe} = 12$$

$$I_B = 0.004 \text{ Amps}$$

$$V_B = I_B \times R_B$$

$$R_B = \frac{V_B}{I_B} = \frac{3.6}{0.004} = 900 \Omega \cong 1K\Omega$$

$$V_B = \text{voltage output from the ports of 89551} = 3.6V$$

### 3.4.1 Operation of the relay to rotate the D.C motor:

When the motor is to rotate right then, a logic level of 0 will be at p1.0 and a logic level of 1 at p1.1, this energizes the top relay which makes the motor rotate right. The reverse is the case if the logic levels are reversed on p1.0 and p1.1; this will energize the lower relay, making the motor move left. When the logic levels are the same on both p1.0 and p1.1 (i.e. p1.0 and p1.1 are both on 0 or 1), both the upper and lower relays will be at the same potential thereby causing the D.C motor not to rotate. (Both p1.0 and p1.1 are output pins of the microcontroller belonging to port one).

The solar tracker uses a 12V motor and is powered by two 6V relay. This was done so that the motor speed is reduced, together with the mechanical unit; it ensures that the system moves slowly. This has an advantage in that the system does not overshoot the movement of the sun. Fig. 9 shows a complete circuit diagram of the project.

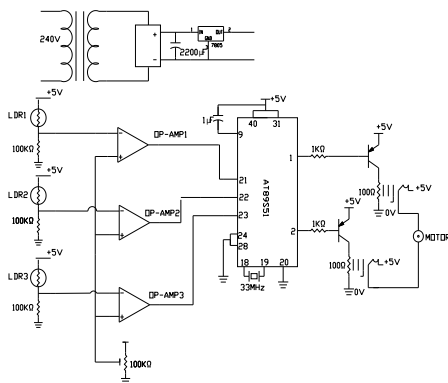

Fig 9 Complete circuit diagram

## 4. Results and Discussion

Hardware and software portions of the project were separated into stages while developing the overall system. The portions consisted of light detection, motor driving, software tracking, and software enhancements. Building and testing smaller sections of the system made the project more manageable and increased efficiency

by decreasing debugging time. The project performs the required functions envisioned at the proposal phase. The testing of the project started with the testing of the power supply unit to ensure it could supply the required power to the circuit. The motor controller was tested next to ensure that it would rotate in the clockwise, anticlockwise as well as stop positions.

After the whole system unit (electrical and mechanical) had been coupled, the solar elevation tracker was tested as a functional unit was found and found to working. The first test on the solar w tracker was carried out with a 60W bulb. When light was directed more on one sensor, the system was found to adjust to a position that balanced light on both sensors. The light was then directed on the other sensor to ensure that the system could both ways (east and west). The same test was carried out under direct sunlight. The sensors were shaded individually and same desired result was obtained.

The project performs the required functions envisioned at the proposal phase. However, while satisfied with software operation and simulation, less satisfaction was obtained from the photocell. It was discovered that the photocell needs to be shielded such that light can be directed narrowly to its surface. This was done by placing a black vinyl tube around the photocell to create a tunnel and help shield it from light that is not directly in its direct path.

## 5. Future Work

The goals of this project were purposely kept within what was believed to be attainable within the allotted timeline. As such, many improvements can be made upon this initial design. That being said, it is felt that this design represents a functioning miniature scale model which could be replicated to a much larger scale. The following recommendations are provided as ideas for future expansion of this project:

- Increase the sensitivity and accuracy of tracking by using a different light sensor. A phototransistor with an amplification circuit would provide improved resolution and better tracking accuracy/precision.
- Utilize a dual-axis design versus a single-axis to increase tracking accuracy.

## 6. Conclusion

This paper has presented a means of controlling a sun tracking array with an embedded microprocessor system, a working software solution for maximizing solar cell output by positioning a solar array at the point of maximum light intensity. This project presents a method of searching for and tracking the sun and resetting itself for a new day. While the project has limitations, this provides an opportunity for expansion of the current project in future years.

## 7. References

- [1] P. Rhushi Prasad, H.V. Byregowda, P. B. Gangavati Experiment Analysis of Flat Plate Collector and Comparison of Performance with Tracking Collector European Journal of Scientific Research ISSN 1450-216X Vol.40 No.1 (2010), pp.144 -155 © EuroJournals Publishing, Inc. 2010 <http://www.eurojournals.com/ejsr.htm>
- [2] Kalogirou SA. Design and construction of a one-axis sun-tracking system. *Sol Energy* 1996;57(6):465–9.
- [3] Alata M, Al-Nimr MA, Qaroush Y. Developing a multipurpose sun tracking system using fuzzy control. *Energy Convers Manage* 2005;46: 1229–45.
- [4] Roth P, Georgiev A, Boudinov H. Design and construction of a system for suntracking. *Renew Energy* 2004;29(3):393–402.
- [5] Bakos GC. Design and construction of a two-axis sun tracking system for parabolic trough collector (PTC) efficiency improvement. *Renew Energy* 2006;31:2411–21.
- [6] Tomson T. Discrete two-positional tracking of solar collectors. *Renew Energy* 2008;33:400–5.
- [7] Huang BJ, Sun FS. Feasibility study of one axis three positions tracking solar PV with low concentration ratio reflector. *Energy Convers Manage* 2007;48:1273–80.
- [8] Kalogirou S. Design of a fuzzy single-axis sun tracking controller. *Int J Renew Energy Eng* 2002;4(2).
- [9] Abu-Khadra Mazen M, Badranb Omar O, Abdallah S. Evaluating multi-axes sun-tracking system at different modes of operation in Jordan. *Renew Sust Energy Rev* 2008;12(3):864–73.
- [10] Abdallah S. The effect of using sun tracking systems on the voltage–current characteristics and power generation of a flat plate photovoltaic's. *Energy Convers Manage* 2004;45:1671–9.
- [11] Abouzeid M. Use of a reluctance stepper motor for solar tracking based on a programmable logic array (PLA) controller. *Renew Energy* 2001;23: 551–60.
- [12] Koyuncu B, Balasubramanian K. A microprocessor controlled automatic sun tracker. *IEEE Trans Consum Electron* 1991;37(4):913–7.
- [13] Abdallah S, Nijmeh S. Two axes sun tracking system with PLC control. *Energy Convers Manage* 2004;45:1931–9.
- [14] Rubio FR, Ortega MG, Gordillo F, López-Martínez M. Application of new control strategy for sun tracking. *Energy Convers Manage* 2007;48(7): 2174–84.
- [15] Yousef HA. Design and implementation of a fuzzy logic computer-controlled suntracking system. In: Proceedings of the IEEE international symposium on industrial electronics; 1999. p. 1030–4.
- [16] Roth P, Georgiev A, Boudinov H. Cheap two axis sun following device. *Energy Convers Manage* 2005;46:1179–92.
- [17] Georgiev A, Roth P, Olivares A. Sun following system adjustment at the UTFSM. *Energy Convers Manage* 2004;45:1795–806.

## Appendix

### Program code for the microcontroller:

```

start:
mov p2, #11111111b
mov p1, #11111100b
first:
mov A, p2
cjne A, #00000011b, ab
clr p1.0
clr p1.1
sjmp first
ab:
cjne A, #00000001b, do
er:
setb p1.0
clr p1.1

sjmp first
do:
cjne A, #00000010b, me
dr:
clr p1.0
setb p1.1

sjmp first
me:
cjne A, #00000000b, first
ko:
setb p1.0

```