

Development Of Robotic Arm Based Diagnostic System For Clinical Tele-Monitoring

¹Folorunso, T.A., ²Olaniyi, O.M., ³Nuhu, B.K., ⁴Bima, M.E., ⁵Ajani, O.S.

^{1, 4} Department of Mechatronics Engineering

^{2, 3, 5} Department of Computer Engineering

Federal University of Technology, Minna, Nigeria

¹funso.taliha@futminna.edu.ng

ABSTRACT

Over the years there has been a lot of advancement in the quest to improve the process of diagnosing deadly clinical diseases such as Ebola and Middle East Respiratory Syndrome (MERS), etc. One of such improvements is the development of diagnostic systems such as the Da Vince machine. However, the cost of acquisition of such systems is very high and requires interaction between the medical attendants and patients at some points. Hence, the need for a tele-diagnostic system that will reduce the attendant to patient interaction for these deadly and tropical diseases. This work, presents a robotic arm based tele-diagnostic system for remotemonitoring of patient with endemic deadly disease like Ebola and MERS. The robotic arm in the developed system has three Degree of Freedom (DOF) with a temperature sensor as the end effector of the arm which allows interaction between the robot arm and the patients in the clinical environment. The arm was completed using servo motors to achieve each DOF and a network of encoders was developed to control the arm within its workspace based on the mapped signals provided to the servo motors by the ATMEGA368 Microcontroller unit which was programmed using Arduino Integrated Development Environment. To process and visualize the patient's body temperature values from the sensor, a clinical software was built in the processing version 2.2.1 environment which communicates serially through an RS232 cable with the microcontroller unit. A Graphic User Interface (GUI) was also developed to show the variation in the patient's body temperature graphically. Several testing and validation were carried out and the results obtained showed that operating the robotic arm without any program delay introduced will result to an unstable display of temperature data on the GUI.

Key words: Diagnosis, Clinical Diseases, Robotic arm, Degree of Freedom, Robot Workspace, End Effector, Arduino Graphic User

Interface, servo motors.

1. BACKGROUND TO THE STUDY

Robotics is basically defined as the study, design and use of robot systems for risk inclined operations. Robots in general are used in industries to perform unsafe, hazardous, highly repetitive, and unpleasant tasks. (Elfasakhany, Yanez, Baylon, & Salgado 2011). Robotic arms are systems capable of performing the basic motion of the human arm. These systems have found a variety of applications in different fields of endeavours replacing the human arm in performing some of its task (Gapar, 2011). To achieve this, several kinds of sensors or grippers are used as end effectors based on the application. Telemonitoring involves the use of telecommunication devices which allow medical attendants to frequently monitor patients whose diagnosis may require increased vital signs assessment (De & Puers,(2012), Masuda, Kimura, Tateishi, & Ishihara (2001)). Hence telemonitoring devices help to provide more accurate and timely patient assessments of body vitals. The use of robotics in telemonitoring helps to bridge the patient-attendant gap which is the open issue of what telemonitoring strives to solve (. The latest innovations in the field of robotic medicine cuts across the use of robots and its components for high precision medical activities such as diagnosis, surgical operations and medical parameter data acquisitions.

2. STATEMENT OF PROBLEM

The success of medical diagnosis of a patient's health condition is majored upon the availability of basic measurements of physiological parameters of the patient known as body vitals (Ma, Penney, Bos, Frissen, De Fockert, King & Rinaldi, 2009). Vital signs monitoring is considered one of the most performed operations by nurses in order to monitor patient's progress and any irregularities. Nurses typically visit each patient and manually record vital sign readings, such as blood pressure, temperature, respiratory rate and pulse rate. However, this process exposes them to the risk of being infected by patients of communicable diseases like EBOLA and data obtained from this method may not be accurate (Yang, Kankanhalli, Ng, & Lim 2015). Although several systems have been designed to provide contactless detection and analysis of human vitals, most of these systems are very expensive in terms of cost and their response times are very high making them unsuitable. Hence, the need for a quicker and cost effective system with minimal power requirements which can be used to measure and monitor human vitals in health centers. (Iyer, Garg, Pathak & Ghosh,, 2013).

3. OBJECTIVE

The main objective of this study is to develop a low cost three Degree of Freedom (DOF) robotic arm with sensors used as its end effector, which is capable of monitoring body vitals with no or minimal contact between patients and health workers. Hence this work presents a two phase project where we have developed a three degree of freedom robotic arm and used a LM35 temperature sensor as its end effector to measure body temperature and built a software for temperature monitoring.

4. METHODOLOGY

The robotic arm design was classified into two: mechanical design and electrical design. The mechanical part is comprised of the moving parts. In designing the mechanical part, accuracy must be considered to ensure appropriate motion of the robotic arm and to eliminate any challenge as the robotic arm is in motion.

The electrical part of the design comprises of the microcontroller circuitry and its accessories, servo motors, the temperature sensor and a wired link of encoders used to achieve desired arm motion.

4.1 The Mechanical Design

The basic mechanical design involves the interaction between the moving parts of the arm, and the direction of motion for each of the actuators to achieve a maximum robot workspace with the available degrees of freedom. The Free Body Diagram (FBD) for the design is shown in Figure 1. From the figure, the basic interaction between each of the actuators and their displacement from each other is depicted. The length of each part of the arm is also shown in the Figure 1. A very important design consideration is the dimension. The design must show the required dimensions to match with the servo motor torque and to achieve a maximum robot workspace. The basic design was achieved in cinema 3D and is shown in Figure 2. Acrylic sheets of 1/8 thickness were used for the design. By the end of the design a prototype of the robot arm was built.

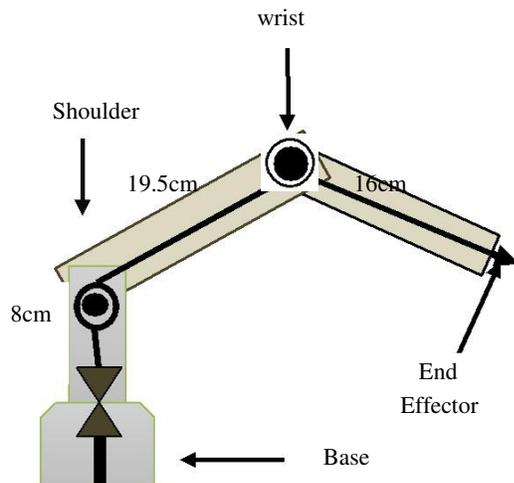

Figure 1: Robot Arm Free Body Diagram



Figure 2: Basic Robot Arm Design

4.2 Electrical Design

The electrical design in Figure 3 shows the interaction of the electrical components in the system and how they are connected to each other. The essential part of the design was completed using Fritzing software which is an open source platform for electrical designs. Several adjustments have been made to the initial design to achieve the final design which produced the desired results upon simulation. Arduino development board with on board ATMEGA368 microcontroller was used in the implementation. Servo motors were chosen as actuators during implementation because they include mechanisms which provide automatic feedback to the motors to adjust their position accordingly.

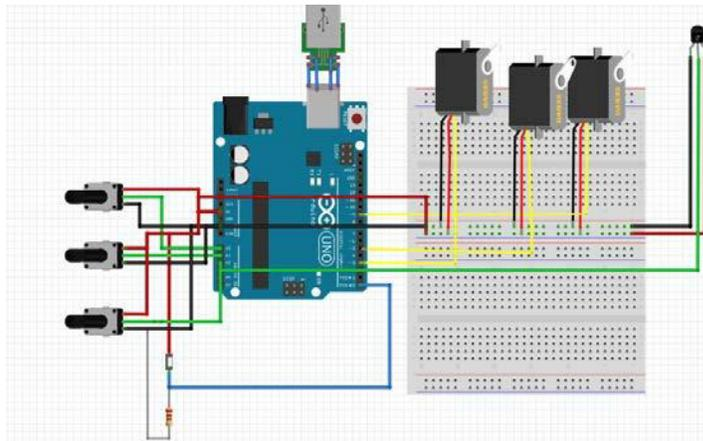

Figure 3: Electric Design Circuit.

4.3 Control Mechanism

The control of the robotic arm is achieved through signals provided through a wired link of potentiometers which are sent to the servo motors through the microcontroller circuitry. The control mechanism for servo motors is of basically two types: the servo sweep and the servo knob. The servo sweep drives the servomotor to basic angles of 0, 90, and 180 degrees, while the servo knob drives the servo to any angle within the ranges of 0 to 180 degrees. Servo sweep are used for automated robotic systems. For this project, the servo knob mechanism was employed to provide flexibility in robotic arm workspace. This is because data could be acquired from varied locations within the robot's workspace. The map algorithm in arduino was used to map values of the encoders spanning between 0 and 1023, to its equivalent values in the range of 0 and 180 which are fed into the servo motors.

4.3.1 Robot Arm Inverse Kinematics

Inverse kinematics involves calculating the joint angles to obtain a desired position and orientation of the end-effector. From Figure 3 and using cosine rule we have:

$$(x^2 + y^2) = l_1^2 + l_2^2 - 2l_1l_2 \cos(180 - \theta_2) \quad (1)$$

$$\text{Since } \cos(180 - \theta_2) = -\cos(\theta_2) \quad (2)$$

Where θ_2 is the angle between the shoulder and the wrist servo motors.

θ_1 is the angle between the wrist servo and the end effector.

θ_0 is the angle between the base and shoulder servo motors.

Then the equation (1) becomes

$$(x^2 + y^2) = l_1^2 + l_2^2 - 2l_1l_2 \cos(\theta_2) \quad (3)$$

Therefore,

$$\cos\theta_2 = \frac{x^2 + y^2 - l_1^2 - l_2^2}{2l_1l_2} \quad (4)$$

$$\text{Hence, } \theta_2 = \arccos \frac{x^2 + y^2 - l_1^2 - l_2^2}{2l_1l_2} \quad (5)$$

Again from Figure 3

$$\frac{\sin\beta}{l_2} = \frac{\sin\gamma}{x^2 + y^2}, \alpha = \arctan \frac{y}{x} \quad (6)$$

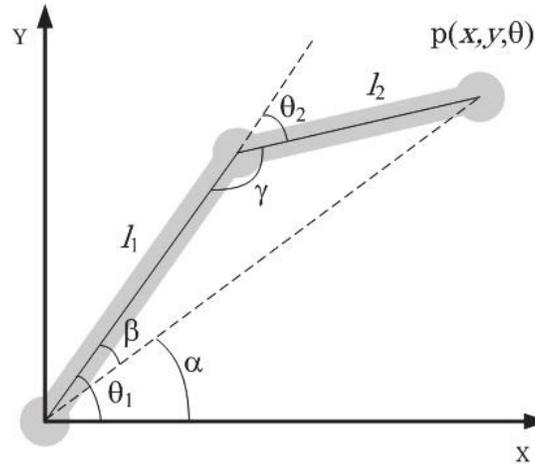

Figure 4: XY plane

$$\text{Since: } \sin(\beta) = \sin(180 - \theta_2) = \sin \theta_2 \quad (7)$$

$$\beta = \arcsin \left[\frac{l_2 \sin \theta_2}{\sqrt{x^2 + y^2}} \right] \quad (8)$$

$$\sin \theta_2 = \alpha + \beta \quad (9)$$

Then θ_1 can be expressed as

$$\theta_1 = \arcsin \left[\frac{l_2 \sin \theta_2}{\sqrt{x^2 + y^2}} \right] + \arctan \frac{y}{x} \quad (10)$$

$$\theta_0 = \arctan \frac{y}{x} \quad (11)$$

4.4 The Graphical User Interface (GUI)

The GUI as shown in Figure 7 was developed using processing software version 2.2.1 which is an open source software that communicates with the arduino development board directly from a PC via a RS232 cable. The sensor data are sent to the computer system through the Universal Serial Bus (USB), these values are then processed and displayed graphically as shown in Figure 7. The software also creates a text file (.txt) that keeps the historical temperature readings. Figure 8 shows a screen shot of temperature values from the text file.

5. DATA PRESENTATION

Several tests were carried out to validate the robot arm and its components. These tests involved the individual components and the entire prototype. At first, the motion of the arm was found to be unstable during testing. This was due to some connections that were not tight and that was corrected. Figure 5 shows the system control unit during component testing and Figure 6 shows the developed robotic arm. Based on the operations of the robotic arm, the measured current consumption data are presented in three levels as shown in Table 1.

Table 1: Current Consumption of the System.

CURRENT CONSUMPTION LEVEL	RANGE(MA)
Low	0 to 29
High	15 to 28
Very High	35 to 70

The GUI developed used to visualize temperature data measured through the system involves two display sections, the first section shows the current temperature value in degrees Celsius and the other section is an oscilloscope kind of interface which displays sudden rise or decrease in temperature. This interface is shown in Figure 7 while Figure 8 shows a text file which contains the history of temperature values measured.

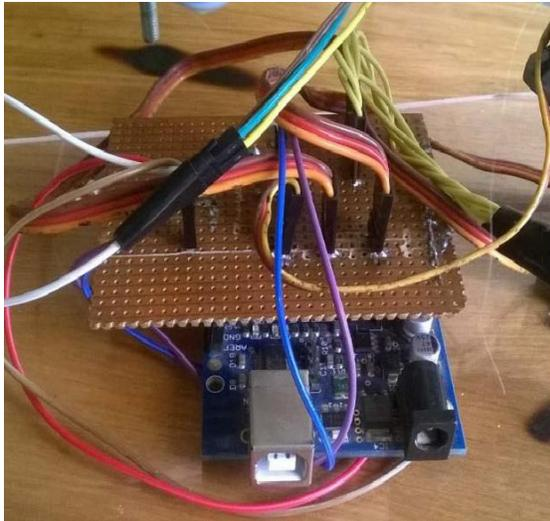

Figure 5: System Control Unit.

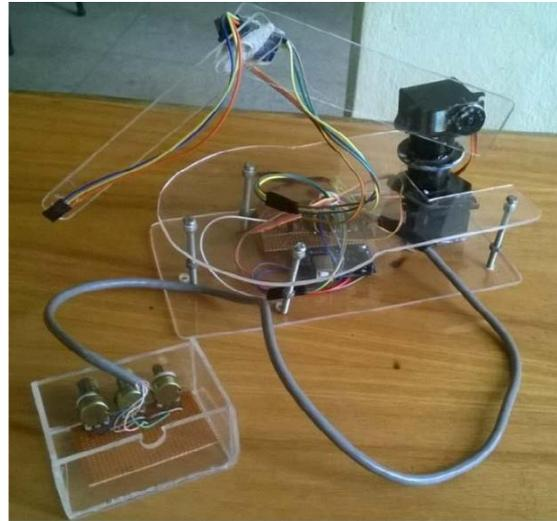

Figure 6: Robotic Arm Prototype

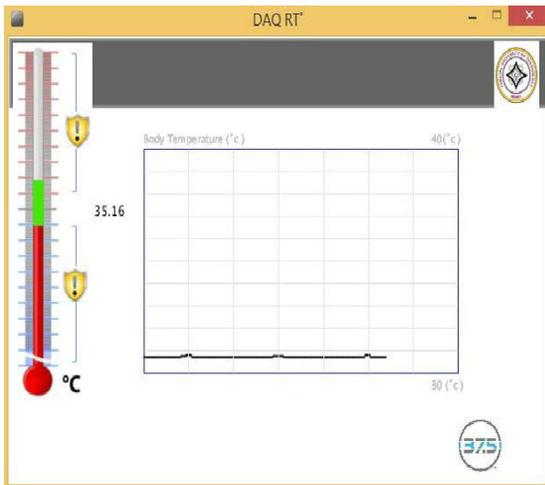

Figure 7: Temperature Data Plot

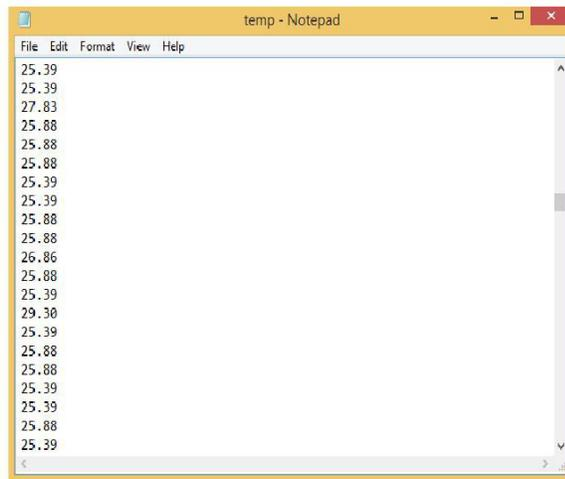

Figure 8: Temperature Data

6. DISCUSSION OF FINDINGS

The findings, analysis and discussion from the developed prototype robotic arm are presented in this section. The robotic arm prototype was successfully developed and was tested. The results showed that it performs its task based on the input from the encoders. The performance of the system was evaluated in terms of current consumption and response time. The current consumption depends on the state of the robotic arm and operation of the end effector (Temperature Sensor). The current consumption was calculated using a multimeter with the mA selection. The probes of the multimeter were connected in series with the “Vin” pin and the regular VCC/+5V pin of the Arduino board. From the experiment, three different levels of current consumed by the system were identified as presented in Table 1 and Figure 9. The first level (low) was read when the arm was not in motion and the end effector was not sampling. The second level (high) of current consumption occurred when the arm was at rest but sensing operation was carried out by the end effector. The third level of current consumption (very high) was when the end effector was sampling and the arm was also in motion.

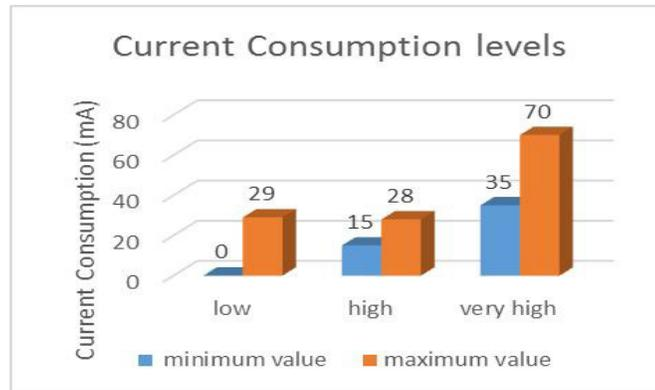

Figure 9: Graph Showing Current Consumption

The result of current consumption ascertains that the current consumption depends on the state of the robotic arm and operation of the end effector (Temperature Sensor). The response time of the system in terms of the motion of the arm was measured to be 0.5 seconds, to ensure proper visualization of temperature data on the GUI a delay of 500ms was introduced to the operation of the microcontroller during programming, therefore a total delay of 1.0 seconds was incurred.

7. CONCLUDING REMARKS

The objectives of our proposed tele-diagnostic system for remote monitoring was achieved with a complete prototype for the designed three DOF based robotic arm and GUI for temperature data acquisition on a personal computer using RS232 serial communication between the computer and the microcontroller. Although it was observed that the temperature data obtained while the robotic arm is still in motion were inconsistent, this is due to several analogue sensed values being sent to the microcontroller at the same time. In conclusion, a three degree of freedom robotic arm has been developed which is capable of monitoring temperature with a system delay of 1 seconds and minimal current consumption when compared with systems developed in earlier works which has current consumption in terms of hundreds of milliamperes (mA) and system delay of about 5 seconds.

8. CONTRIBUTIONS TO KNOWLEDGE

Based on this study, research findings and the review of literatures on the development of a low cost 3DOF Robotic Arm Tele-diagnostic system for remote health monitoring of patients with deadly communicable diseases, one of the major underlying issues of every telemonitoring device which is the patient-attendant gap is bridged and the risk of infection of medical attendants also reduced.

REFERENCES

1. De Clercq, H., & Puers, R. (2012). A neonatal body sensor network for long-term vital signs acquisition. *Procedia Engineering*, 47, 981-984.
2. Elfasakhany, A., Yanez, E., Baylon, K., & Salgado, R. (2011). Design and development of a competitive low-cost robot arm with four degrees of freedom. *Modern Mechanical Engineering*, 1(02), 47-55.
3. Gapar, F. G. (2011). *Design and develop robotic arm for automated guided conveyor*. Doctoral dissertation, Universiti Malaysia Pahang pp.1-31
4. Iyer, B., Garg, M., Pathak, N. P., & Ghosh, D. (2013). Contactless Detection and Analysis of Human Vital Signs Using Concurrent Dual-Band RF System. *Procedia Engineering*, 64, 185-194.
5. Ma, Y., Penney, G. P., Bos, D., Frissen, P., De Fockert, G., King, A., ... & Rinaldi, C. A. (2009). Evaluation of a robotic arm for echocardiography to X-ray image registration during cardiac catheterization procedures. In *Engineering in Medicine and Biology Society, EMBC 2009. Annual International Conference of the IEEE* (pp. 5829-5832).
6. Masuda, K., Kimura, E., Tateishi, N., & Ishihara, K. (2001). Construction of 3D movable echographic diagnosis robot and remote diagnosis via fast digital network. In *Engineering in Medicine and Biology Society, 2001. Proceedings of the 23rd Annual International Conference of the IEEE* (Vol. 4, pp. 3634-3637).
7. Yang, Z., Kankanhalli, A., Ng, B. Y., & Lim, J. T. Y. (2015). Examining the pre-adoption stages of healthcare IT: A case study of vital signs monitoring systems. *Information & Management*, 52(4), 454-467.