

DESIGN AND PERFORMANCE ANALYSIS OF A HYDRAULICALLY  
OPERATED BRIQUETTING MACHINE: CASE STUDY OF RICE HUSK

BY

ONUH, ADA ANNAFELICIA

2006/24038EA

DEPARTMENT OF AGRICULTURAL AND BIORESOURCES

ENGINEERING

SCHOOL OF ENGINEERING AND ENGINEERING TECHNOLOGY

FEDERAL UNIVERSITY OF TECHNOLOGY, MINNA, NIGER STATE,  
NIGERIA.

FEBRUARY, 2012

DESIGN AND PERFORMANCE ANALYSIS OF A HYDRAULICALLY  
OPERATED BRIQUETTING MACHINE: CASE STUDY OF RICE HUSK

BY

ONUH, ADA ANNAFELICIA

2006/24038EA

BEING A FINAL YEAR PROJECT SUBMITTED IN PARTIAL  
FULFILLMENT OF THE REQUIREMENTS FOR THE AWARD OF  
BACHELOR OF ENGINEERING (B.ENG) DEGREE IN AGRICULTURAL  
AND BIORESOURCE ENGINEERING, FEDERAL UNIVERSITY OF  
TECHNOLOGY MINNA, NIGER STATE, NIGERIA.

FEBRUARY, 2012

## DECLARATION

, ONUH ADA ANNAFELICIA hereby declare that this project titled "Design and Performance Analysis of a Hydraulically Operated Briquetting Machine: Case Study of Rice Husk" is an original work that was undertaken and written by me. It has not been presented before for any degree, diploma or certificate at any university or institution. Information derived from personal communication, published, and unpublished works of others were duly acknowledged by means of reference.

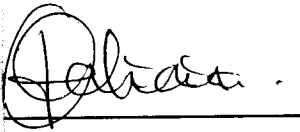

Onuh, Ada Annafelicia

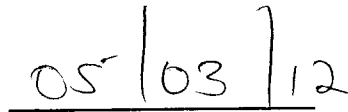

Date

2006/24038EA

## CERTIFICATION

The project entitled "Design and Performance Analysis of a Hydraulically Operated Briquetting Machine: Case Study of Rice Husk" by Onuh, Ada Annafelicia, meets the regulations governing the award of the degree of Bachelor of Engineering (B.ENG.) of the Federal University of Technology, Minna, and it is approved for its contribution to scientific knowledge and literary presentation.



Engr. Dr. Adgidzi

Supervisor

03.03.2012

Date



Engr. Dr. P.A. Idah

Head of Department

5/3/2012

Date



External Examiner

22-02-2012

Date

## **DEDICATION**

This project is dedicated to the Almighty God my creator, without whom I wouldn't be where I am today. I also would like to dedicate it to my mother, Mrs. Florence O. Onuh (JP), the most remarkable person I know.

## ACKNOWLEDGEMENTS

My utmost gratitude is to the Almighty God who is my greatest asset and wealth and has seen me throughout my course of study and to the finish of this project.

I would like to express my profound gratitude to my supervisor, Engr. Dr. Adgidzi for answering all my questions patiently. He gave me his time and did his best to make sure I got it right.

I deeply appreciate the efforts of the Head of Department, Engr. Dr. P.A. Idah, my lecturers Engr. Dr. I. E. Ahaneku, Engr. Dr. O. Chukwu, Engr. Dr. A. Gbabo, Dr. Otache, Engr. Mrs. Bose Orhevba., Dr. Mrs. Z. Osunde and the entire lecturers and staff of agric and bio-resources engineering department for all the valuable knowledge they imparted in me.

My profound gratitude goes to my parents, Mr. and Mrs. Clement Onuh, their love, support, kindness and prayers are nothing short of overwhelming. Also to my siblings Desmond, Helen, Loveth, John, Sylvester and Elizabeth whose wonderful enthusiasm, support and love cannot be rivaled.

Sometimes in life, we are blessed with the appearance of the right person at the right time, and at a difficult crossroad in my life, that was my friends. Dr. Nafisa Bala, Patricia Uli, Musa Ahmadu, Adaobi Ike-Eze, Deola (and baby Praise), Adaora Onyejeakor, Belinda Aturu, Mary Ifere, my project group members- Onuh Ogbonnaya, Olaolu Taiwo and Ejim Ogah, my YWAP family and a host of others, only with your kind hearts and sincere love could you have helped me find my direction, and what's more, you've kept me on track. How lucky I am to have you all.

God bless you all.

## ABSTRACT

Briquetting of agricultural by-products represents one of the possible solutions to the local energy shortages in many developing countries. It constitutes a positive solution to the problem of increasing rates of desertification in many areas worldwide. Agricultural by-products are not attractive as a household fuel source for urban areas because they are very bulky and have low energy intensity. This study puts forward a machine of simple design, which could be manufactured locally in both rural and urban areas and of a high productivity that can be used to increase the energy intensity of selected agricultural by-products through a process known as briquetting. The work includes an evaluation of rice husk, production and test of rice husk briquettes. The methodology involved evaluating the physical and thermal characteristics of rice husk briquettes, its combustion efficiency, comparing their characteristics, compressive strengths and burning efficiency to that of coal and fuel wood. From the tests carried out, coal was found to have a high calorific value at 19.18MJ/Kg which places it above all the other samples tested. Rice husk briquettes without binder was found to have the highest burning efficiency (at 71.72%) when compared to rice husk with binder (41.10%), charcoal (19.09%) and fuel wood (1.32%). Further investigations can be carried out based on this project to determine the efficiency of rice husk briquettes in comparison to briquettes made from other agricultural by-products.

## CONTENTS

Cover page	i
Title	ii
Declaration	iii
Certification	iv
Dedication	v
Acknowledgement	vi
Abstract	vii
Table of contents	viii
List of Tables	xii
List of Figures	xiv
List of Plates	xv
Notations	xvi
<b>CHAPTER ONE</b>	
<b>1.0 INTRODUCTION</b>	
1.1 Background to the Study	1
1.2 Statement of the Problem	2
1.3 Objectives of the study	3
1.4 Justification of the Study	4
1.5 Scope of the Study	4
<b>CHAPTER TWO</b>	
<b>2.0 LITERATURE REVIEW</b>	
2.1 Brief History of Briquetting	5
2.2 Briquetting Technology	6
2.2.1 Piston Presses	8
2.2.2 Pellet Presses	9
2.2.3 Screw Presses	9



2.3	Briquette Making	10
2.4	Advantages of Briquettes	11
2.5	Characteristics of Briquettes	12
	2.5.1 Handling Characteristics	13
	2.5.2 Combustion Characteristics	14
2.6	Advantages of Briquetting	17
2.7	Forms of Briquettes	18
2.8	Binders	20
2.9	Charcoal	21
	2.9.1 Charcoal Briquette	21
2.10	Rice Husk	22
	2.10.1 Advantages of briquetting rice husk	24
<b>CHAPTER THREE</b>		
<b>3.0</b>	<b>MATERIAL AND METHODS</b>	
3.1	Design consideration and material selection	26
3.2	Various components of the Briquetting Machine	26
	3.2.1 Briquetting Chamber	26
	3.2.2 The "C" Section Bar	28
	3.2.3 Shaft	28
	3.2.4 Hydraulic Jack	28
	3.2.5 Pressure Gauge	28
	3.2.6 Pistons	28
	3.2.7 Base	29
3.3	Design Analysis and Calculations	31
	3.3.1 Assumptions	31
	3.3.2 Choice of hydraulic jack capacity	31
	3.3.3 Determination of cylinder thickness	32

3.3.4	Calculation of maximum shear stress in the cylinder	34
3.3.5	Calculation of cylinder volume	35
3.3.6	Determination of compression ratio	35
3.3.7	Determination of thickness of the briquette machine cover	36
3.3.8	Spring Design	37
3.3.8.1	Determination of the number of turns of spring	38
3.3.8.2	Determination of mean diameter of spring	38
3.3.8.3	Pitch of coil	39
3.3.9	Power Requirement	39
3.3.9.1	Power required compressing the briquetting material	40
3.3.9.2	Power required to drive the hydraulic pump	41
3.4	Description and Principle of Operation of the Briquetting Machine	41
3.4.1	Description of the Briquetting Machine	41
3.4.2	Principle of Operation of the Machine	46
3.5	Procedure for Briquetting Rice Husk without Binder	46
3.6	Procedure for Briquetting Rice Husk with Binder	47
3.7	Briquetting Technology Used	48
3.8	Experimental Tests	48
3.8.1	Moisture Content	48
3.8.2	Compressive Test	49
3.8.3	Burning Test	51
3.8.4	Determination of Ash Content	51
3.8.5	Calorific Value	52
3.8.6	Burning Efficiency	53
3.9	Statistical Analysis	54
	<b>CHAPTER FOUR</b>	
4.0	<b>RESULTS AND DISCUSSION</b>	55

4.1	Results	55
4.1.1	Dimension of Briquettes	55
4.1.2	Moisture Content	56
4.1.3	Compressive Strength of the samples	57
4.1.4	Burning Test	58
4.1.5	Comparative Test	59
4.1.6	Statistical Analysis	60
4.2	Discussion of Result	62
4.2.1	Compaction Ratio	62
4.2.2	Firmness of Briquettes	63
4.2.3	Burning Efficiency and Calorific value	63
4.3	Material Selection	64
4.4	Material and Labour cost	65
4.4.1	Material cost	65
4.4.2	Labour cost	66
4.4.3	Overhead cost	66
4.4.4	Cost of producing briquettes	66
	<b>CHAPTER FIVE</b>	
5.0	<b>CONCLUSION AND RECOMMENDATION</b>	69
5.1	Conclusion	69
5.2	Recommendation	70
	<b>REFERENCES</b>	71

## LIST OF TABLES

Table 2.1	Calorific values and ash content of Agricultural residues	15
Table 2.2	Typical Analysis of Rice Husk	23
Table 4.1	Dimensions of briquettes without binder	55
Table 4.2	Dimensions of briquettes with binder	55
Table 4.3	Moisture content of the briquettes without binder	56
Table 4.4	Moisture content of the samples with binder	56
Table 4.5	Moisture content of Charcoal	57
Table 4.6	Moisture content of Fuel wood	57
Table 4.7	Compressive strength of Briquettes without Binder	57
Table 4.8	Compressive strength of Briquettes with Binder	58
Table 4.9	Compressive strength of Charcoal	58
Table 4.10	Compressive strength of fuel wood	58
Table 4.11	Burning efficiency characteristics of the samples	58
Table 4.12	Comparative test	59
Table 4.13	Mean and standard deviation of the moisture content of the samples without binder	60
Table 4.14	Mean and standard deviation of the moisture content of the samples with binder	60
Table 4.15	Mean and standard deviation of the moisture content of charcoal	60
Table 4.16	Mean and standard deviation of the moisture content of fuel wood	61
Table 4.17	Mean and standard deviation of the compressive strength of the briquettes without binder	61
Table 4.18	Mean and standard deviation of the compressive strength of the briquettes with binder	61

Table 4.19	Mean and standard deviation of the compressive strength of charcoal	61
Table 4.20	Mean and standard deviation of the compressive strength of fuel wood	62
Table 4.21	Compaction ratio of the briquettes	62
Table 4.22	Breakdown of the Material cost	65
Table 4.23	Breakdown of production cost of briquettes produced/month	67

## LIST OF FIGURES

Figure 3.1	Isometric view of the briquetting machine	27
Figure 3.2	Line drawing of the briquetting machine	30
Figure 3.3	Exploded view of the briquetting machine	43
Figure 3.4	Orthogonal view of the briquetting machine	44
Figure 3.5	Component parts of the briquetting machine	45

## LIST OF PLATES

Plate 3.1	Briquetting Machine	41
Plate 3.2	Extraction of formed briquettes	46
Plate 3.3	Formed Rice husk briquettes	47
Plate 3.4	Briquettes placed in the oven to dry	49
Plate 3.5	Manually operated compressive test machine	50

## NOTATIONS

The following parameters were used during the design analysis and calculations.

SYMBOL	MEANING	UNIT
P	Pressure	N/m <sup>2</sup>
F	Force	N
A	Area	m <sup>2</sup>
b	Breadth	m
h	Height	m
t	Thickness	m
d	Diameter	m
l	Length	m
V	Volume	m <sup>3</sup>
m	Mass	Kg
g	Acceleration due to gravity	m/s <sup>2</sup>
W	Work done	Nm
$\sigma_c$	Circumferential stress	N/m <sup>2</sup>
$\sigma_l$	Longitudinal Stress	N/m <sup>2</sup>
$\tau$	Maximum shear stress	N/m <sup>2</sup>
$P_{Euler}$	Critical load	N
$\Sigma$	Summation	
$l_e$	Equivalent length	m
E	Modulus of elasticity	N/m <sup>2</sup>
n	Factor of safety	



## CHAPTER ONE

### 1.0 INTRODUCTION

#### 1.1 Background to the Study

Agriculture has for several years formed the backbone of Nigeria's economy, contributing approximately 30.2% of the gross domestic product. Developing countries like Nigeria produce large quantities of agro-residues such as rice husk, coffee husk, groundnut shells, cotton stalks, cow dung, and saw dust as milling residue and is also available in large quantities, but they are used inefficiently causing extensive degradation to the environment. Briquetting could solve this transporting, storage, handling and environmental degradation problems associated with agro residues. (Adegoke and Mohammed, 2002)

A briquette is a block of flammable matter which is used as fuel to start and maintain a fire (Microsoft Encarta, 2009).

Briquettes are usually made from materials that cost little or no money to obtain, such as old newspapers or partially decomposed plant waste, and can be used as alternative fuel to charcoal, firewood, or coal, and may cost less. Briquetting is one of the several compactions in the general category of densification where a material is compressed under pressure to form a product of higher bulk density, lower moisture content, uniform size and shape and material properties. Briquetting or biomass densification represents a set of technologies for the conversion of biomass into fuel (Adegoke and Mohammed, 2002)

Common types of briquettes are charcoal briquettes and biomass briquettes. Biomass briquettes are made from agricultural waste and are a replacement for fossil fuels such as oil or coal, and can be used to heat boilers in manufacturing plants, and also have applications in developing

countries. Biomass briquettes are a renewable source of energy and avoid adding fossil carbon to the atmosphere. Biomass is usually bulky and rather messy to use (Ehab, 2004).

Briquetting is the process of converting low bulk density biomass into high density and energy concentrated fuel materials (Wikipedia, 2009).

The process of briquetting makes compact uniform sized pellets of the biomass. This also permits blending of different kinds of biomass fuels to get more uniform burning and consistent calorific value. (Adegoke et al, 1999)

A huge quantity of agro-residues is produced in the country but they are used in-efficiently causing extensive pollution to the environment. The major residues are rice husk, rice straw, saw dust, bagasse, groundnut shells e.t.c. Apart from the problems of transportation, storage and handling, the direct burning of loose biomass in the environment is greatly associated with a very low thermal efficiency, low bulk density, higher moisture content and widespread pollution. Report shows that in developing countries, energy from biomass continues to be the main source of energy, mostly in its traditional forms designed to meet demands of domestic use. With regard to energy shortage and environmental issues, it is widely accepted that renewable energy will play a major role in the foreseeing year. It has been reported that over 33% of energy consumption for developing countries can be supplied from this kind of rice husk. (Jekayinfa and Omisakin 2005)

## **1.2 Statement of the Problem**

Nigeria (even though an oil producing Nation) has challenges of energy crisis. According to Adegoke and Mohammed (2002), Nigeria is passing through an unprecedented crisis. The author inclined that;

1. Non-renewable energy such as kerosene and gas are outside the reach of the common man.
2. The supply of electricity, another conventional energy source is epileptic where available or non-available at all in most part of the country.

The main domestic and household fuels Nigeria families use for cooking and business are firewood, charcoal and kerosene. Up to this present time these fuels are not cheap and affordable. Greater percentage of Nigerian families is still in search of cheap and affordable fuel for use at home and for business.

Most of the developed nations who mostly depend on importing oil as their major source of energy are cutting back on import of oil and are moving towards the development of energy. A very good example of such nation is the USA, which has reviewed the technology of obtaining energy and fuels from biomass energy which already is a commercial energy resource (Akinbami, 1998).

The use of fuel wood is creating a human and environmental crisis in developing countries worldwide. Half the world's 2 billion fuel wood users face fuel shortages. 100 million already experience virtual fuel wood famine. In Africa, 40% of energy requirements are met by fuel wood. Wood burning creates deforestation, desertification and erosion and many sub-saharan countries have had over three quarters of their forest cover depleted. ([www.paceproject.net](http://www.paceproject.net))

### **1.3 Objectives of the Study**

There are four major objectives:

1. To design and construct a hydraulically-operated briquetting machine.

2. To test the machine for briquette production using rice husk.
3. To carry out analysis of the briquettes.
4. To compare with charcoal and wood fuel.

#### **1.4 Justification of the Study**

Agricultural wastes which can cause health and environmental hazards are processed into briquettes which can be produced on a commercial level thus turning waste into wealth. Briquetting agro-residues need a briquetting machine. Most of the existing machines are rarely available to rural people, use electricity and the cost of fuel is high, bulky and expensive. They need skilled man power to operate and maintain them. Many people in Nigeria still adopt the traditional method of briquetting using hands. This method of briquetting is associated with a number of problems; time consuming, tedious, accuracy is compromised, requires a great deal of skill and effort to briquette, low production and wastage.

This project seeks to come up with a fast briquetting technique which may be employed by those involved in briquette making. Fast briquetting results into increased output per day to meet the briquette demand plus minimized amount of drudgery.

#### **1.5 Scope of the Study**

This project work covers the design and fabrication of a hydraulically-operated briquetting machine and the production and analysis of briquettes from rice husk (with and without the use of binder), compared to charcoal and fuel wood.

## CHAPTER TWO

### 2.0 LITERATURE REVIEW

#### 2.1 Brief History of Briquetting

Industrial method of briquetting dates back to the second part of the 19<sup>th</sup> century. The compaction of loose combustible material for fuel making purposes was a technique used by most civilians in the past, though the methods used were not more than simple bundling, balling or drying. Briquetting was proposed in Russia in the 1830's by the Russian inventor F. P. Veshniakov, who developed a method of producing hard briquettes from waste wood, charcoal and hard coal. (Prokhorov, 1982)

In the beginning of the nineteenth century, sawdust briquettes were made with binding materials such as tar, resin and clay which bind the small particles together. None of these processes attained great importance because of their relatively high costs compared to wood and conventional charcoal fuel (Wamukonya and Jenkins, 1995).

Fuel briquettes emerged as a significant business enterprise in the 20<sup>th</sup> century. In the 1950's several economic methods were developed to make briquettes without a binder. A multitude of factories throughout the world produces literally ten million of tons of usable and economic material that met the household and industrial energy needs. During the two world wars, household in many European countries made their own briquette from soaked waste paper and other combustible domestic waste, using simple lever-operated press (Grigorian, 2003)

According to Barnard (1985), the following three critical factors contributed to the resurgence of briquetting.

- i. Change in the economics of using fuel briquette as an energy source necessitated by recent developments of briquette processing and binding.
- ii. Shortage of fuel wood, which has become increasingly severe in most of the developing countries.
- iii. Steady increase by environmental concerns to address the problem of domestic and urban waste disposal, a problem that briquetting can remedy.

The uses of various forms of organic briquetting seem to have been common during worldwar I and during the 30s depression, the modern mechanical piston briquetting machine was developed in Switzerland based upon German development in the 30s. (Jekayinfa and Omisakin, 2005)

## **2.2 Briquetting Technology**

Screw extrusion briquetting technology was invented and developed in Japan in 1945. According to CRA as of April 1969, there were 638 plants in Japan engaged in manufacturing sawdust briquettes, known as 'Ogalite', amounting to a production of 0.81 MTY. The fact that the production of briquettes quadrupled from 1964 to 1969 in Japan speaks for the success of this technology. This technology should be differentiated from such processes as the 'Prest-o-log' technology of the United States, the 'Glomera' method in Switzerland or 'Compress' method in West Germany.

At present two main high pressure technologies: ram or piston press and screw extrusion machines, are used for briquetting. While the briquettes produced by a piston press are completely solid, screw press briquettes on the other hand have a concentric hole which gives better combustion characteristics due to a larger specific area. The screw press briquettes are also

homogeneous and do not disintegrate easily. Having a high combustion rate, these can substitute for coal in most applications and in boilers. (Grover and Mishra, 1996)

Historically, biomass briquetting technology has been developed in two distinct directions. Europe and the United States has pursued and perfected the reciprocating ram/piston press while Japan has independently invented and developed the screw press technology. Although both technologies have their merits and demerits, it is universally accepted that the screw pressed briquettes are far superior to the ram pressed solid briquettes in terms of their storability and combustibility. Japanese machines are now being manufactured in Europe under licensing agreement but no information has been reported about the manufacturing of European machines in Japan.

Worldwide, both technologies are being used for briquetting of sawdust and locally available agro-residues. Although the importance of biomass briquettes as substitute fuel for wood, coal and lignite is well recognized, the numerous failures of briquetting machines in almost all developing countries have inhibited their extensive exploitation. (CRA, 1987)

Briquetting technology is yet to get a strong foothold in many developing countries because of the technical constraints involved and the lack of knowledge to adapt the technology to suit local conditions. Overcoming the many operational problems associated with this technology and ensuring the quality of the raw material used are crucial factors in determining its commercial success. In addition to this commercial aspect, the importance of this technology lies in conserving wood, a commodity extensively used in developing countries and leading to the widespread destruction of forests. (UNDP/ World Bank, 1986)

### 2.2.1 Piston Presses

Piston presses are used to compress dust shavings or chip waste which is created from workings with materials such as wood, paper, metal, foam or plastic. Making briquettes from loose particles creates a significant volume reduction. This leads to easier material handling for transport and storage and helps to prevent the risk of sparks which lead to fires. The hydraulic briquetting presses apply considerable force to compress the material into compact briquettes. This process changes the material properties in a way that creates a product similar to those of the solid raw material. This is why briquettes are able to be burned and used as energy source.

The operation of a press is simple. It is done by feeding the material into the hopper of the machine by hand or by connecting the unit under your dust collection system. The machine is turned on and the agitator spins to push the material into the open chamber at the bottom of the unit. An auger then transports the material into the pre-compression chamber. From there the cylinder is filled and the material is pressed to produce the desired briquette length. No glues or adhesives are used in this process which means a clean reusable product is produced.

The diameter of the briquette is closely related to the output of the machine. A unit product of 1ton/hect of briquettes will have a die 8-10cm in diameter, the relationship is rather inflexible and may constrain potential markets for the product of bigger machines, small stoves may not be able to burn such large pieces (Janczak, 1980)



### 2.2.2 Pellet Presses

These operate by extruding small diameter (10-30mm) pellets through a die which has many holes. The extruding mechanism is often an eccentric roller which moves inside the large cylindrical or conical die, such machine were originally developed for the production of animal feedstuff and mineral ore pellets (CRA, 1987).

The smaller product size and high capacity of these types of presses was before the 60s utilized only in the pressing of fodder pellets and similar applications, since then a limited number of energy applications have materialized in the USA (woodex0. There have been a few applications of pellets presses in developing countries solely for energy purposes, notably Kenya, Zimbabwe and Zambia (Kocaman *et, al.* 1983).

### 2.2.3 Screw Presses

The screw press is another mechanical press machine. The earliest development work on screw press was carried out in the USA in the 1930s. In screw presses, material is fed continuously into a screw, which forces the material into a cylindrical die. This die is often heated to raise the temperature to the point where lignin flow occurs. If the die is not heated, the temperature may not rise sufficiently to cause lignin flow and binding materials may have to be added. The briquettes from screw machines are often of higher quality than from piston units. The screw press is usually sized in the range 75-250kg/h, though larger machines are available. The production of screw presses has been taken up by manufacturers in Asia and more recently in Europe. (Janczak, 1980)

## 2.3 Briquette Making

The process involved in briquetting are drying, crushing, grinding and sieving. The extrusion production technology of briquettes is the process of extrusion screw wastes (straw, sunflower husks, buckwheat, etc.) or rice husk under high pressure when heated from 160 to 350 C °. The quality of such briquettes, especially heat content, is much higher comparing with other methods like using piston presses. (Adegoke and Mohammed, 2002)

Briquetting compresses dust or shavings e.g. wood, plastics, metals, paper into several shapes and sizes. Making briquettes can considerably reduce the volume of the materials. This enables better handling for storage and transportation, as well as preventing a dust explosion risk. The material properties of the briquettes that are produced are similar to those of the solid raw material. This is why they are usually burned as an energy source recycled into new materials. The hydraulic briquetting presses that are used in the briquetting processes apply considerable force to compress the material into compact briquettes.

The briquette material is obtained and sun dried to remove some moisture. The material is crushed after drying and then sieved to obtain the part for the briquette production. The material is channeled to a compressing equipment known as screw extruder (briquettor) or forming machine while it is still in a hot/warm state. (Adegoke and Mohammed, 2002).

Optionally, the briquettes are subjected to a thermal treatment in an oxidizing, neutral or reducing atmosphere so that the temperature at the core of the briquettes is in the range of from about 101° to about 350°C for between about 1 minute and about 24 hours; the treatment is preferably carried out in an oxidizing atmosphere in such a way that the temperature at the core of the briquettes is in the range of from about 230° to about 300°C, preferably for between about

20 minutes and about 2 hours. The object of this optional treatment is to completely dry the briquette. The optional thermal treatment of the briquettes is preferably carried out without submitting them to mechanical constraint. A thermal treatment in a furnace (tunnel oven) or in a basket is therefore preferred. The energy required for the thermal treatment may be supplied by a gas (for example, flue gas diluted with air) or a fluidized bed. If required, oxygen accelerators can be added, for example, phosphorus pentoxide, phosphoric acid, phosphoric acid salts which decompose at temperatures in excess of 300°C, organic phosphorus derivatives, Lewis acids, or compounds which decompose while giving off oxygen, such as, for example, the peroxides or perchlorates.

Briquettes can be produced with a density of 1.2 g/cm from loose biomass of bulk density 0.1 to 0.2 g/cm. These can be burnt clean and therefore are eco-friendly and also those advantages that are associated with the use of biomass are present in the briquettes. The conversion efficiencies are as low as 40% with particulate emissions in the flue gases in excess of 3000mg/Nm. In addition, a large percentage of un-burnt carbonaceous ash has to be disposed of. In the case of rice husk, this amounts to more than 40% of the feed burnt. As a typical example, about 800tonnes of rice husk ash are generated every day in Ludhiana (Punjab) as a result of burning 2000tonnes of husk. Briquetting of the husk could mitigate these pollution problems while at the same time making use of this important industrial/domestic energy resource. (Ehab, 2004)

#### **2.4 Advantages of Briquettes**

According to Jekayinfa and Omisakin (2005), briquette of mass has been proposed as one of the ways in which fuel shortage in developing nation might be alleviated. Briquettes could be an

important alternative energy for cooking in household especially during periods of charcoal and fuel wood shortages. Additional advantages of briquetting biomass wastes are:

1. It is a means of turning waste to wealth.
2. Reduction in oil and other costly fossil fuel needs.
3. Production of good quality fuel that is often cheaper than charcoal.
4. Simplicity of technology involved in making the briquettes.

## **2.5 Characteristics of Briquettes**

Briquettes are justified mainly by the reduction of volume of bulky waste material. After densification, there are two main qualities of a briquette and they are:

1. It shall remain solid until it has served its purpose.
2. It shall perform well as a source of fuel.

According to Prokhorov (1982), that the first aspect of the product should not crumble and disintegrate when handled, stored and transported, is mainly a function of the quality of the densification process for a given raw material, the second aspect is mainly to the properties of the raw material and shape and density of the individual briquette. In the following we call these factors;

- I. Briquette handling characteristic
- II. Fuel characteristic

The distinction is not always clear and sometimes they interfere with each other for example; improving the handling characteristic by making a denser briquette often has a detrimental effect on its combustion behavior (Barnard, 1985).

### 2.5.1 Handling Characteristics

i. Density – Most processes are capable of producing briquettes with densities above 1000kg/m<sup>3</sup> i.e the individual briquettes will sink in water, (this is in fact, good if crude test for the briquette quality). The upper limit for the density is set by the physical density of each raw materials which for ligneous material is about 1500kg/m<sup>3</sup>, the density of individual pieces in termed apparent density, high pressure processes such as mechanical piston presses, pellet presses and some screw extruders, make briquettes in the 1200-1400kg/m<sup>3</sup> density range (Prokhorov, 1982).

This means that for briquettes with apparent densities in the 1200-1400kg/m<sup>3</sup> range, the resulting bulk densities are 600-700kg/m<sup>3</sup> for comparisons, the bulk density of the raw material could be as low as 40kg/m<sup>3</sup> for some grades of bagasse to about 150-200kg/m<sup>3</sup> for a variety of agro-residues and wood wastes, the higher bulk density of briquettes will significantly increase the distance over which it is economic to transport a residue in order to get a market for it. In briquetting, the resulting density is affected to a significant degree by the particle size or the raw materials, finely ground material, for example sanding dust from wood plants, will make very dense briquettes but requires high pressures and temperatures to agglomerate without a binder (CRA, 1987).

ii. Friability – This factor is a measurement of the briquettes to mechanical action that will affect them when handled and transported. Tests can be done either in a rotating drum or by repeatedly dropping samples from a specified height in both methods, the samples are screened and the fraction retained is used as an index of briquettes friability (CRA 1987). It is difficult to give a figure for an acceptable friability index as the relationship between test results and reality has never been studied, in the work carried out by the CRA some samples received an index of 0, i.e.

the briquettes had disintegrated entirely after a certain time which clearly indicates an inadequate briquette quality, when the briquettes score higher in tests, say between 0.5 and 1.0 such results are more difficult to interpret, they do have a function though when comparing several processes in order to find the most suitable for a given material (CRA 1987). General observation at a number of operating plants suggests that briquettes produced by mechanical piston presses and screw presses hard enough to be transported by lorry for considerable distances without degradation.

iii. Resistance to Humidity – Inherent binders (lignin) and most external binder are water soluble. This results in one weak point in briquette quality, which is that briquettes are not subject to water or humid air (CRA 1987). Briquettes and pellet have to be stored under cover and they do have a limited lifetime under humid condition. The latter problem appears to be only minor even in tropical countries, the dense, hard-surfaced briquettes produced in mechanical piston presses and screw presses with heated dies have enough resistance to humidity to withstand the rainy season in India, Thailand and Brazil provided they are lowered.

### 2.5.2 Combustion Characteristics

i. Calorific Value - One of the most important property of a fuel is its calorific value, that is the amount of energy per kg it gives up when burned. According to Barnard, 1985 cited in Sulaiman (2007), the calorific value of wood and agro-residues can be calculated using the following formula which although originally derived for wood can be used for most agro-residues with little alteration. Gross or Higher calorific value (HVC) =  $20 \times (1 - A - M) \text{ MJ/kg}$

Where, A = ash content

M = moisture content of the actual fuel

Net or low calorific value (LCV), takes into account unrecovered energy from water vapour from inherent moisture and from the oxidation of hydrogen content, is sometimes used for references purposes especially in industrial applications. In wood and most agro-residues, the hydrogen content is about 6% by weight on the dry and ash free basis, which means that the above formula would be changed as follows

$$\text{Lower Calorific Value (LCV)} = 18.7 \times (1 - A - M) - 2.5 \times M$$

Where, A = ash content

M = moisture content of the actual fuel (MJ/kg)

For material with low ash content and moisture contents between 10% and 15%, like that in most briquettes from wood and agro-residues, the resulting calorific value are HCV 17-18MJ/kg while LCV range from 15.4MJ/kg to 16.5MJ/kg.

Table 2.1 Calorific Value and Ash Content of Agricultural residues (Barnard, 1985 cited in Sulaiman, 2007)

Material	Ash content (%)	HCV (MJ/kg) (Oven dry)
Alfalfa straw	6.0	18.4
Almond shell	4.0	19.4
Cassava stem	--	18.3
Coconut husk	0.8	20.1
Coconut husk	6.0	18.1
Cotton stalks	17.2	15.8

Cotton stalks	3.3	17.4
Groundnut shell	--	19.7
Groundnut shell	4.4	20.0
Maize stalks	6.4	18.2
Maize stalks	3.4	16.7
Maize cobs	1.5	18.9
Maize cobs	1.8	17.4
Olive pits	3.2	21.4
Pigeon pea stalk	2.0	18.6
Rice straw	--	15.2
Rice straw	19.2	15.0
Rice husks	--	15.3
Rice husks	16.5	15.5
Soya bean stalks	14.9	16.8
Soya bean stalks	--	19.4
Sunflower straw	--	19.4
Walnut shell	--	21.0
Wheat straw	1.1	21.1
Wheat straw	--	18.9

ii. Briquette Density - Ehab, (2004) mentioned that the primary density ( $\rho_0$ ) is not constant, even when the same mass is weighed and pressed. That is because of the difference in material



structure. These factors always affect the material volume, so that after a certain pressure the material reaches the maximum density ( $\rho_{\max}$ ).

When a material is pressed under axial pressing force, a compact briquette will be produced.

The primary density of the material ( $\rho_0$ ) is.

$$\rho_0 = \frac{V}{M}$$

Where;

$M$  = mass of the material, g

$V$  = volume of the material, cm<sup>3</sup>

This primary density depends on:

- The way the material is filled into the press form (loose or pressed by a device),
- The structure of the material (the relation between leaves and stem, the content of roots, the resistance to crack etc.),
- The moisture content and the age of the material

## 2.6 Advantages of briquetting

The briquetting process offers the following advantages:

- The net calorific value per unit volume is increased
- The densified product is easy to transport and store
- Disposal of residue is facilitated

- The fuel produced is uniform in size and quality.

Although there are crops with both higher and lower residue yields, it is reasonable to assume that about 25% of any dry agricultural feedstock consists of residues. These residues are not properly collected or utilized efficiently. The major limitation in utilizing them is their low bulk densities and irregular size, making transportation, handling and storage costs enormous. These limitations can be overcome by compacting and converting the residues into a high density form (FAO, 1990 as cited in Ehab, 2004).

Briquettes can be produced with a density of up to 1.2 g/cm<sup>3</sup> from loose biomass with a bulk density of 0.1 and 0.2 g/cm<sup>3</sup>. When using these briquettes for energy purposes, the optimal density is between 0.9 and 1.2 g/cm<sup>3</sup>. The briquettes are also affected by the moisture content. Briquettes with a moisture content of less than 18% are constant and durable (Ehab, 2004).

## 2.7 Forms of briquettes

There are different forms of compressed materials. These forms are cubes, pellets and crumbles. According to Ehab, 2004, ASAE (1991) defined these forms as follow:

- Cubes: An agglomeration of ungrounded ingredients. The configuration of the agglomeration may take any form
- Pellets: An agglomeration of individual ground ingredients, or mixture of such ingredients, commonly used for animal feed
- Crumbles: Pelletized feed reduced to granulate form

The best known forms of the compressed materials are pellets and briquettes. In general there is no difference in properties between them. The small-length pressed materials are called pellets

and the coarse materials are called briquettes. The use of briquetting for the conversion of agricultural residues is comparatively recent. Briquetting makes these wastes easier to transport, to handle and to store. It is efficient to use briquettes as an alternative fuel to coal, and additionally this reduces the volume of polluting gases such as sulphur (S) and phosphorus (P) fumes. Increasing the material density through briquetting will increase the energy density. The briquettes are normally cylindrical in shape with a diameter of about 25-100 mm and a length of about 40-400 mm (FNR, 2000 as cited by Ehab, 2004).

The briquetting of biomass has so far posed different problems in different kinds of machines and remains yet to establish a standard procedure for each biomass. The main reason is the changing physio-chemical characteristics of different biomass under different conditions. For the purpose of large scale commercialization, it is highly essential to study the behaviour of each biomass for its application in briquetting. For many years, methods of briquetting have been investigated and it is an established fact that typically very high power levels are required to form stable high density aggregates. This is true for piston, screw and roller type extrusion processes. This high pressure amounts to high electrical energy consumption and high wear rate of machine parts. Some of the studies made earlier have revealed that the addition of heat benefits by relaxing the inherent fibres in biomass and apparently softening its structure resulting in release of some bonding or gluing agent on to the surface. Reed *et al* as cited by Grover & Mishra, (1996) also observed in laboratory scale experiments that the work requirement for densification can be reduced by a factor of about two by preheating the raw material. The results reported by Sayed *et al* also cited by Grover & Mishra, (1996) have established that the preheating lowers the power input. They have studied power consumption in the screw press briquetting of preheated sawdust at different die temperatures. (Grover & Mishra, 1996)

## 2.8 Binders

Biological material contains natural cementing agent which may be pectin substances, liquid or other compound, which hold the cells together to form tissues. These substances soften when heated at low temperature. The effect of adding bonding agent is to enhance cohesion and reduce pressure requirements. Binders hold components by both mechanical and chemical adhesion. Bonding occurs when the binder molecules adhere to specific points in the molecular structure of the adherent. A number of binding agent have been tried as additives in briquetting. One of this is the cassava flour. It is made of the tropical root crop cassava. The crop is quite robust, as it can be relatively easily grown in infertile soil. When it is cooked, cassava flour makes an excellent and combustible binder. The cooked cassava flour will be the glue that holds together the agricultural waste. This cassava flour has a unique property, such as its high viscosity and its resistance to freezing, which make it competitive with other industrial starches. (<http://www.bpre.gov.ph/PHIndustry/cassava.htm>). Other forms of binders include industrial starch, starch obtain from maize, guinea corn, etc.

Binders used for briquetting can be classified into two;

### 1. Smokeless binders:

Meal binders such as cassava starch, corn starch, and other starches are smokeless but not moisture resistant. They are normally used in the range of 4 to 6 percent on the oven-dry basis. In some cases, small amounts of moisture resistant binders are used.

### 2. Smoky binders:

Smoky but moisture resistant binders are tar, pitch, asphalt, sugar cane molasses, and others. Recommended percentage for wood- tar pitch and coal-tar pitch is less than

30percent. Briquettes with these blinders are smoky when ignited. But this characteristic is not a drawback for briquettes used in smelting and heating. For home use it could be very annoying.

## **2.9 Charcoal**

The agricultural residues are produced abundantly after harvest of each crop in our villages. Most of these residues are burnt in the open field. However using Biomass Charcoal Briquetting technologies, these residues, can be used for generating an alternative fuel which is cost effective and environmentally friendly. It can also add income to the family.

Charcoal is a black or dark gray form of carbon, produced by heating wood or another organic substance in an enclosed space without air. It is used as fuel, as an absorbent, in smelting, in explosives and for drawing. (Microsoft Encarta, 2009).

### **2.9.1 Charcoal Briquettes**

According to Yuksel, *et. al*, (2008), charcoal made out of the modified pit method can be used in making charcoal briquettes. Charcoal briquettes are charcoal dust compactly massed by a binder of cassava flour, corn or sweet potato starch. As fuel, charcoal briquettes have higher heating value than wood or plain charcoal. They are almost smokeless when burning and give off intense and steady heat. They can be used in the smelting of iron ore since it is compact and dense.

Aside from their being used as fuel, charcoal briquettes can be converted to other industrial products. In the chemical industry, they are used in the manufacture of carbon disulfide, carbon electrodes, carbon tetrachloride, carbon carbide, sodium cyanide and activated charcoal for purifying air or water. (Kocaman, *et. al*, 2008)

Yuksel, *et. al*, (2008) explained that to make the charcoal briquettes, well-charred charcoal made through the modified pit method and cassava corn or camote starch as binder is needed. Charcoal briquettes can be produced manually or mechanically. For a small-scale briquettes maker, the manual method will suffice. The method is simple and can be easily applied in places where coconuts abound. First, smokeless charcoal is bought or prepared; this type of charcoal is shiny and gives a metallic sound when tapped. The charcoal is powdered into dust particles by hammering with a mallet or wooden hammer or by passing through a hammer mill. Cassava corn or camote starch is cooked under moderate heat. The starch has a syrupy consistency which is neither too thick nor too thin. This will be used as binder. The charcoal dust and the binder are mixed thoroughly in a pail or any available container. When the mixture has reached an even consistency, it is kneaded in the same way as making dough for bread. The resulting mixture is molded into desired shape and size using the hands or an improved wooden molder such as a sungkahan. Then the briquettes are dried under the sun. Or oven cooked in an improvement tapahan type dryer using pieces of wood, coconut shells and dusk and other waste materials for fuel. ([www.thaisumi.com/charcoalbriquetting.aspx](http://www.thaisumi.com/charcoalbriquetting.aspx))

## **2.10 Rice Husk**

Rice husk is a by-product of milling paddy. It is produced after the paddy is passed through the husker and conveyed outside the mill through an aspirator (Wikipedia, 2009).

Rice husk is a hard layer comprising kariopsis which consists of two parts; called lemma and palea. The machining process will separate the rice grain rice ball and a residual loss or milling.

Rice husk is classified as a biomass that can be used for different purposes such as industrial raw materials, fodder and energy or fuel (Wikipedia 2010).

Rice husk may either be whole or grounded, depending on the type of husker used. For rice husk briquettes, whole rice husk is better to use in briquetting. In addition, ground rice husk may require a higher-pressure blower. A kilogram of paddy can produce about 200grams of rice husks. About 20% of the weight of paddy and this may vary in few percent depending on the variety of rice. Therefore, a 1-ton paddy per hour rice mill is capable of producing 200kilogram of rice husks per hour. For a day long operation of 10 hours, a total of 2 tons of rice husks can be produced (Yuksel *et. al*, 2005).

The husk surrounding the kernel of rice accounts for approximately 20% by weight of the harvested grain (paddy). The exterior of rice husks are composed of dentate rectangular elements, which themselves are composed mostly of silica coated with a thick cuticle and surface hairs. The mid region and inner epidermis contains little silica. In small single stage mills in developing countries, where bran (the layer within the husk) is not fully separated from the husk, the husk plus bran stream can rise to 25% of the paddy. For larger mills, where the husk and bran are fully separated (the type more likely to be providing the husk for electrical generation), a husk to paddy ratio of 20% is appropriate. Most heating values for rice husk fall in the range 12.5 to 14MJ/kg, lower heating value (LHV). If some bran remains with the husk, it will result in a somewhat higher calorific value. Rice husks have low moisture content, generally in the range of 8% to 10%. The following are typical chemical analyses of rice husk by Yuksel *et. al*. (1956):

**Table 2.2: Typical Analysis of Rice Husk**

<b>Property</b>	<b>Mass</b>	<b>Dry</b>
Carbon (%)	34.61	38.43
Hydrogen (%)	3.79	2.97
Oxygen (%)	41.58	36.36
Nitrogen (%)	0.44	0.49
Sulphur (%)	0.06	0.07
Ash (%)	19.52	21.68

Humidity (%)	9.95	0.00
Volatile matter (%)	55.54	61.68
Calorific value (kJ/kg)	13,800	15,325
Fixed carbon (%)	14.99	16.65
Length of husks (mm)	3	3
Hardness (Moh's scale)	67	52

Rice husk has been extensively used throughout Africa as the main feed stock for briquette; this study investigates the production and usefulness of rice husk as an alternative fuel for household energy. (Olorunisola, 1999).

According to Suharno (1979) water content of rice husk is 9.02%. The straw has a density of type (bulk Density) 1125 kg / m<sup>3</sup>, with a caloric value of 1 kg of flakes of 3300 k. calories.

According to Barnard (1985) rice husk have a higher density of the bales 0.100 g / ml, a calorific value between 3300 -3600 k. calories / kg of straw with the thermal conductivity of 0.271 BTU

### 2.10.1 Advantages of Briquetting Rice Husk

The effective use of Agricultural by-products such as rice husk results in the following advantages according to Ogunrinede (2007)

1. The process increases the net calorific value per unit volume.
2. The denser product is easy to transport and store.
3. The process aids in solving the problem of residue disposal
4. Rice husk briquettes are economical by about 20% compared to coal.
5. Lower pollution while briquette burning due to low ash, sulphur content compared to coal.



6. Generation of employment in rural areas is to the extent of 40 persons (directly & indirectly) per 500 kg/h capacity briquetting plant.
7. Easy storage, handling transportation of rice husk briquettes, higher combustion efficiency and sustained high intensity burning compared to loose husk.
8. The fuel produced is uniform in size and quality.
9. Cleaner burning and reduced smoke improves the health risks to women/kitchen workers.
10. Easy to handle and store.
11. Fire risk is minimized.
12. Easy to transport at lower cost.
13. It turns waste to wealth.
14. Simplicity of the technology involved in making the fuel briquettes and the stoves to burn them.
15. Briquettes can be mass-produced using briquette making machine that can turn out several briquette at the same time.
16. Briquette are cheaper than coal, oil or lignite and once used cannot be replaced.
17. Biomass briquette has a higher practical thermal value and much lower ash content (2-10%) as compared to 20-40% in coal.
18. Briquette has a consistent quality, has burning efficiency, and is ideally sized for complete combustion.
19. Combustion is more uniform compared to coal and boiler response to change in steam requirement is faster due to high quality volatile matter in briquette.
20. Loading, unloading and transport cost are much less and storage requirement is drastically reduced.

## **CHAPTER THREE**

### **3.0 MATERIALS AND METHODS**

This chapter presents the design analysis, procedure for briquetting rice husk, test procedure of rice husk briquette, comparison with other samples (charcoal and fuel wood), combustion test and analysis of rice husk, charcoal and fuel wood.

#### **3.1 Design Consideration and Material Selection**

Economy is the basis of any good design hence material used were carefully selected so as to serve the specific purpose for which they were meant, while at the same time considering cost. The properties of the materials must include resistance to corrosion because corrosion may contaminate the briquette material hence adding unwanted property to the material. Materials like stainless steel, brass, and grey cast iron have better advantage over others but for availability and economic reasons, galvanized mild steel was chosen for this project.

#### **3.2 Various Components of the Briquetting Machine**

##### **3.2.1 Briquetting Chamber**

This unit is used for compressing and molding of the briquette. It is made up of the following;

- i. 4 cylinders 40mm diameter each where the biomass materials are fed for compaction. Based on the diameter of the cylinder, the diameter of the briquette is 40mm and height of 50mm.
- ii. 4 pistons 38.50mm diameter each. Assumption based on the diameter of the cylinders.
- iii. A top cover, 10mm thick.

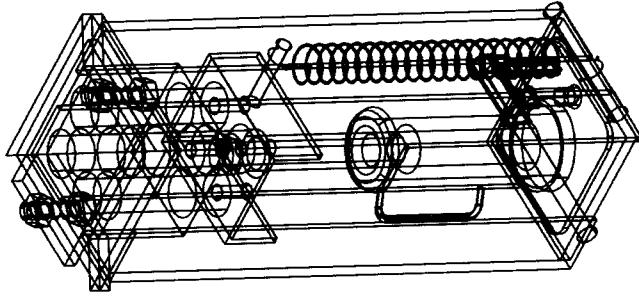



Fig. 3.1 Isometric View of Briquetting Machine

ALL DIMENSION IN MM.

FEDERAL UNIVERSITY OF TECHNOLOGY MINNA.	
ISOMETRIC VIEW OF A BRIQUETTING MACHINE	
DRAWN BY: ONUH ADA FELICIA 2006/24038EA	
DESIGNED BY: ONUH ADA FELICIA 2006/24038EA	
CHECKED BY:	DR. ADGIDZI
APPROVED BY:	DR. ADGIDZI
DATE:	NOVEMBER, 2011
	SYMBOL: 

### **3.2.2 The “C” Section Bar**

This transfers the pressure produced by the hydraulic jack through the connecting rods to the pistons that compress and mold the materials. A circular plate 5mm thick was welded under the “C” section bar, this increases the surface area in which the pressure produced by the hydraulic jack acts.

### **3.2.3 Shaft**

The briquetting machine has two shafts which guides the to and fro movement of the “C” section bar as it is been pushed up and down by the hydraulic jack. It also serves as a base for the briquetting chamber.

### **3.2.4 Hydraulic Jack**

This is the lift unit which raises the “C” section bar, pressurizing the bio materials fed to the cylinders in briquetting chamber from the “C” section bar through the connecting rods to the pistons; finally pressurize the materials against the briquetting chamber cover.

### **3.2.5 Pressure Gauge**

This is linked to the hydraulic jack through the hydraulic piping system. It allows readings of the compaction pressure of briquetting material at any point.

### **3.2.6 Pistons**

The pistons are used to transfer energy from the hydraulic jack to the compression chamber. The pistons tops was of lesser diameter when compared to the internal diameter of the cylinders, this

is allow free movement of the piston and also the create room for fluid to escape during compression.

### **3.2.7 Base**

This provides support to the machine. The machine's weight lies on this part of the machine.

An isometric view of the machine showing all dimensions is shown in figures 3.2 overleaf.

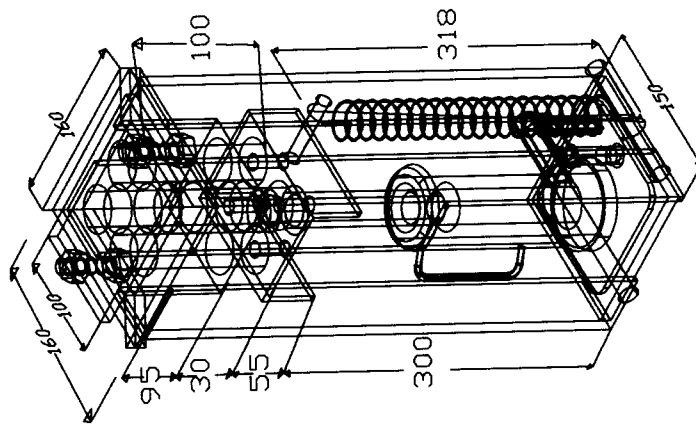

Fig. 3.2 Line Diagram of Briquetting Machine

ALL DIMENSION IN MM.

FEDERAL UNIVERSITY OF TECHNOLOGY MINNA.

ISOMETRIC VIEW OF A BRIQUETTING MACHINE

DRAWN BY: ONUH ADA FELICIA 2006/24038EA

DESIGNED BY: ONUH ADA FELICIA 2006/24038EA

CHECKED BY: DR. ADGIDZI

APPROVED BY: DR. ADGIDZI

DATE: NOVEMBER, 2011

SYMBOL:

### 3.3 Design Analysis and Calculations

#### 3.3.1 Assumptions:

Cylinder diameter = 40mm

Cylinder length = 95mm

Briquetting Chamber cover thickness = 20mm

The distance between each cylinder = 5mm

Piston diameter = 38.5mm

Piston length = 100mm

#### 3.3.2 Choice of Hydraulic jack Capacity

Using charcoal and fuel wood as standard for comparing the briquettes, the maximum force of compaction of charcoal and fuel wood deducted from the compressive test is 20kN and 60kN respectively. Based on assumption, for the briquette to burn longer and more effectively than charcoal and fuel wood, its maximum compaction force has to be more than that of fuel wood and charcoal.

Therefore choosing a compaction force of 80kN for the briquette,

Tonnage Capacity of Hydraulic Jack (C) is given as;

$$C = \frac{F}{1000g}$$

Where

F = compaction force of the briquettes

g = acceleration due to gravity =  $9.8\text{m/s}^2$

$$\text{Therefore, } C = \frac{80000}{(1000 \times 9.8)}$$

$$= 8.16 \text{ tonnes}$$

The size of jack used is 10 tonnes which is the nearest size of jack available.

### 3.3.3 Determination of Cylinder Thickness

From the equation;

$$P_a D = 2tS \text{ (Khurmi and Gupta, 2008)}$$

Where

$P_a$  = maximum pressure on the cylinder wall = the compacting pressure =  $\frac{F}{A}$

D = internal diameter of the cylinder = 40mm = 0.04m

S = tensile strength of the material (mild steel) =  $430 \times 10^6 \text{N/m}^2$  (Khurmi and Gupta, 2008)

t = thickness of the cylinder.

F = maximum force

A = surface area of the piston base

From above, a hydraulic jack of 10tonne was chosen for this project which was designed to carry a maximum load of 10000kg.



$$F = mg$$

$$= 10000 \times 9.8 = 98000N$$

Surface area of the piston base =  $l \times b$

$l$  = Length of the piston base = 100mm

$b$  = Breadth of the piston base = 120mm

$$A = 100 \times 120 = 12000mm^2 = 0.012m^2$$

$$= 0.012m^2$$

$$P_a = \frac{F_t}{\text{surface area}}$$

$$= \frac{98000}{0.012}$$

$$= 8.167 \times 10^6 N/m^2 = 8.167 N/mm^2$$

Therefore

$$8.167 \times 10^6 \times 0.04 = 2 \times 430 \times 10^6 \times t$$

$$2546160 = 860 \times 10^6 t$$

$$t = \frac{326680}{860 \times 10^6}$$

$$t = 0.00038m = 0.38mm$$

From the above calculation, the minimum cylinder thickness is 0.38mm but for safety and availability of material, a thickness of 3mm will be used for this design.

### 3.3.4 Calculation of Maximum Shear Stress in the cylinder

To calculate the maximum shear stress produced in the cylinder.

Using the equation

$$\tau_{\max} = \frac{P_a d}{8t}$$

Where,

d = diameter of the cylinder

P<sub>a</sub> = pressure required for compaction

t = minimum cylinder thickness

$\tau_{\max}$  = Maximum shear stress produced in the cylinder

Where, P<sub>a</sub> = 8.167 N/mm<sup>2</sup>

d = 40 mm

t = 3 mm

$$\tau_{\max} = \frac{8.167 \times 40}{8 \times 3} = 13.61 \text{ N/mm}^2$$

Based on the above calculations, we can conclude that it is safe to use the parameters used in the calculation of the cylinder for fabrication since the maximum shear stress acting in the cylinder is less than the allowable shear stress.

### 3.3.5 Calculation of cylinders volume

The cylinders volume is calculated in order to know the value of agricultural waste that it will contain each batch operation. It can be calculated using equation below

$$V = \frac{\pi}{4} d^2 l$$

Where,  $V$  = volume of cylinder

$d$  = diameter of cylinder = 40mm

$l$  = length of cylinder = 95mm

$$\therefore V = \frac{\pi \times 40^2}{4} \times 95$$

$$V = 119380.52 \text{mm}^3 \text{ or } 1.1938052 \times 10^{-4} \text{ m}^3$$

To get the total volume of the cylinders, we multiply the value of  $V$  by four (number of cylinders)

$$\text{Therefore the volume of the cylinders} = 119380.52 \text{ mm}^3 \times 4 = 477522.08 \text{mm}^3$$

### 3.3.6 Determination of the Compression Ratio

Let the distance travelled by the piston to compress the briquette material to height of 50mm be

$S$

Therefore,  $S$  = height of cylinder – designed height of briquette

Height of cylinder = 95mm

Designed height of briquette = 50mm

$$S = 95 - 50 = 45 \text{ mm}$$

The displacement volume ( $V_d$ ) =  $\frac{\pi}{4} d^2 S$

$$V_d = \frac{3.142 \times 40^2}{4} \times 45$$

$$= 56548.67 \text{ mm}^3$$

And total volume ( $V$ ) = displacement volume ( $V_d$ ) + compression volume ( $V_c$ )

$$V_c = V - V_d$$

$$= 119380.52 - 56548.67 = 62831.85 \text{ mm}^3$$

### 3.3.7 Determination of Thickness of Briquette Cover

From equation

$$t = \sqrt[3]{\frac{KFb^2}{E\delta^2}} \text{ (Khurmi and Gupta, 2008)}$$

Where

$t$  = thickness of the plate

$k$  = constant depending on its length and breath

$F$  = concentrated load

$\delta$  = Maximum displacement

$E$  = modulus of elasticity of the plate

$$K = \frac{b}{a}$$

$b$  = breadth of the plate = 120mm

$a$  = length of the plate = 100mm

$$\therefore K = \frac{120}{100} = 1.2$$

If the maximum deflection  $\delta = 0.3\text{mm}$  (Assumed)

$$E = 220 \times 10^3 \text{N/mm}^2 \text{ (Khurmi and Gupta, 2008)}$$

$$F = 98000\text{N}$$

$$\therefore t = \sqrt[3]{\frac{1.2 \times 98000 \times 120^2}{220000 \times 2^2}} = 12.44\text{mm}$$

### 3.3.8 Spring Design

After the compression or compaction of the briquetting material to produce briquette by the hydraulic jack through the pistons, the formed briquettes are collected at the top of the briquetting chamber by removing the briquetting chamber cover and further jack the hydraulic jack lever till the briquettes is out of the briquetting chamber.

Two helical tensile springs are used to pull back the hydraulic jack lever to its normal height or length once the hydraulic jack valve is released or opened.

Let;

The normal height of the hydraulic jack (height before jacking the lever) be = the free length of the spring = 200mm.

The maximum distance travelled by the hydraulic jack = maximum deflection of the spring =  
100mm

Diameter of the spring wire ( $d$ ) = 3mm (assumed)

Spring index = 5 (assumed)

### 3.3.8.1 Determination of Number of Active Turns of the Springs

Free length of spring =  $n \times d + \delta_{max} + (n - 1) \times 1$  (Khumi and Gupta)

Where

$n$  = number of active turns

$d$  = diameter of spring wire = 3mm

$\delta_{max}$  = maximum deflection of spring = 100mm

$$\therefore 200 = 3n + 100 + (n - 1) \times 1$$

$$200 = 4n + 100 - 1$$

$$200 - 99 = 4n$$

$$n = \frac{101}{4} = 25.25$$

Number of turns of coil = 25 turns

### 3.3.8.2 Determination of the Mean Diameter of the spring

$$\text{Spring index} = \frac{D}{d} = 5$$

Where;

D = mean diameter of the spring

d = diameter of spring wire = 3mm

Therefore,

$$D = 5d$$

$$= 5 \times 3 = 15mm$$

### 3.3.8.3 Pitch of Coil

$$\text{Pitch of coil} = \frac{\text{free length}}{n-1}$$

$$= \frac{200}{25-1} = \frac{200}{24} = 50mm$$

Pitch of coil = 50mm

### 3.3.9 Power Requirement

The power required for the compression and molding of briquettes can be classified into listed below

- i. Power required for compressing the briquette material.
- ii. Power required to drive the hydraulic pump

The summation of these different power components give the total power required by the machine.

Let

$P_t$  = total power requirement of the machine

$P_c$  = power required for compressing the briquette material

$P_h$  = power required to drive the hydraulic pump

Total power ( $P_t$ ) =  $P_c + P_h$

### 3.3.9.1 Power Required for Compressing the Briquette Material ( $P_c$ )

$P_c = W/T$  (Rajput.R.K, 2006)

Where

$W$  = work done by hydraulic jack in compression

$$= mg \times d$$

$m$  = maximum load capacity of hydraulic jack 10 ton (10000kg)

$d$  = maximum distance travelled by jack = 100mm (0.1m)

$g$  = acceleration due to gravity =  $9.8m/s^2$

$T$  = compressing time = 5 minutes = 300 seconds

$$W = 10000 \times 9.8 \times 0.1 = 9800Nm$$

$$P_c = \frac{9800}{300} = 32.67Nm/s$$

$$P_c = 32.67Nm/s$$



### 3.3.9.2 Power Required to Drive Hydraulic Pump ( $P_h$ )

$$P_h = W/T$$

$$W = F \times d$$

Where

W = work done by hydraulic jack in compression

F = minimum force applied on hydraulic pump lever = 40N (Assumed)

d=length of hydraulic pump lever= 0.25m

T = compression time= 5minutes= 300 seconds

$$W = 40 \times 0.25 = 10Nm$$

$$P_h = \frac{10}{300} = 0.033Nm/s$$

$$P_t = P_c + P_h$$

$$= 32.67 + 0.033 = 32.703Nm/s$$

## 3.4 Description and Principle of Operation of the Briquetting Machine.

### 3.4.1 Description of the Briquetting Machine

The machine is equipped with a top cover of dimension 100mm × 160mm which is 10mm thick, the top cover has a handle with two holes on both side as shown in figure 3.5, a briquetting chamber consisting of four cylinders welded close to each other and inside a rectangular metal plate, four flat bars are welded round the four cylinders at top end of the cylinders as illustrated

in figure3.4, the briquetting chamber can produce four briquettes in a batch operation, four pistons of diameter 38.5mm and length of 100mm each that are fitted inside each cylinders of the briquetting chamber. This compresses the briquette materials against the briquetting chamber cover with the help of the piston base, a piston base where the pistons are screwed, it is a “C” sectioned bar, four angle bars on which the briquetting chamber is hanged, a hydraulic jack which is the main source of power to the machine, it is screwed to the base of the machine and the piston base is screwed on the top of the jack as shown in the exploded view of the briquetting machine in figure 3.3. Below is a pictorial view of the machine.

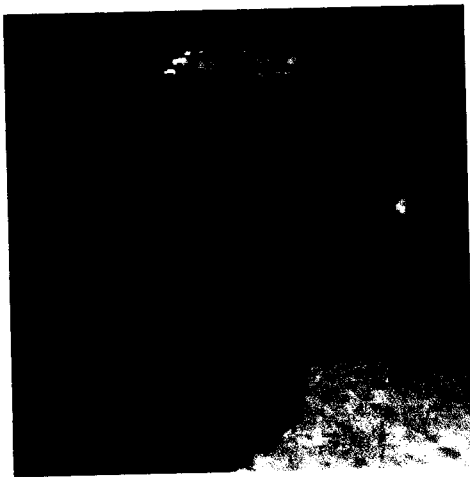
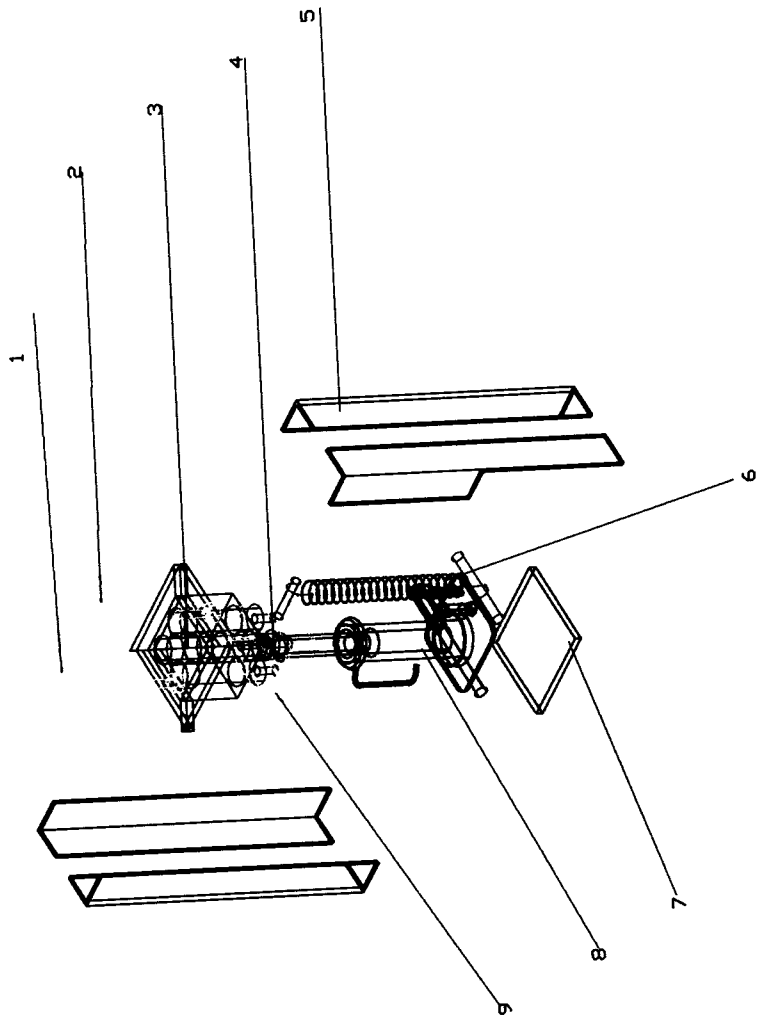

Plate 3.1: Briquetting Machine



S/N	PART
1	BOLT
2	TOP COVER
3	BRIQUETTING CHAMBER
4	PISTON
5	FRAME
6	SPRING
7	BASE
8	HYDRAULIC JACK
9	PISTON BASE

ALL DIMENSION IN MM.

Fig. 3.3 Exploded View of Briquetting Machine

FEDERAL UNIVERSITY OF TECHNOLOGY MINNA  
 EXPLODED VIEW OF A BRIQUETTING MACHINE  
 DEKAN AYINDE AKA FEUCHA 2005/2006  
 DESIGNER: AYINDE AKA FEUCHA 2005/2006  
 SUPERVISOR: DR. AGUIDYI NIGINI  
 DATE: NOVEMBER 2001 SYMBOL: R02

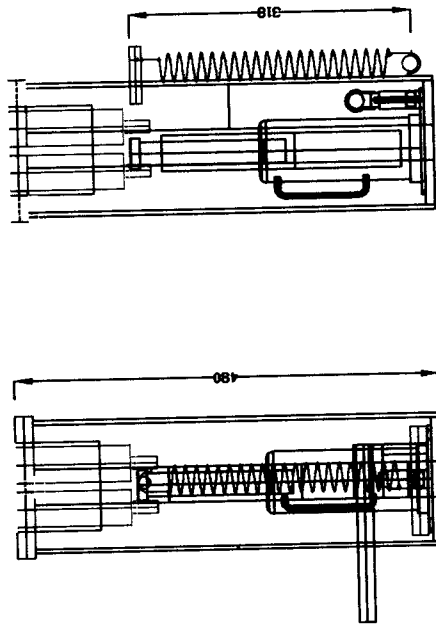

Front

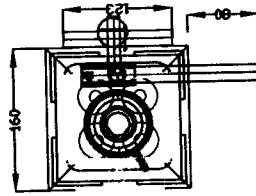

Plan

ALL DIMENSION IN MM.

FEDERAL UNIVERSITY OF TECHNOLOGY MINNA.	
ORTHOGRAPHIC VIEW OF A BRIQUETTING MACHINE	
DRAWN BY:	ONUH ADA FELICIA 2006/24038EA
DESIGNED BY:	ONUH ADA FELICIA 2006/24038EA
CHECKED BY:	DR. ADGIDZI SIGNED:
APPROVED BY:	DR. ADGIDZI SIGNED:
DATE:	NOVEMBER,2011

Fig. 3.4. Orthographic view of Briquetting Machine

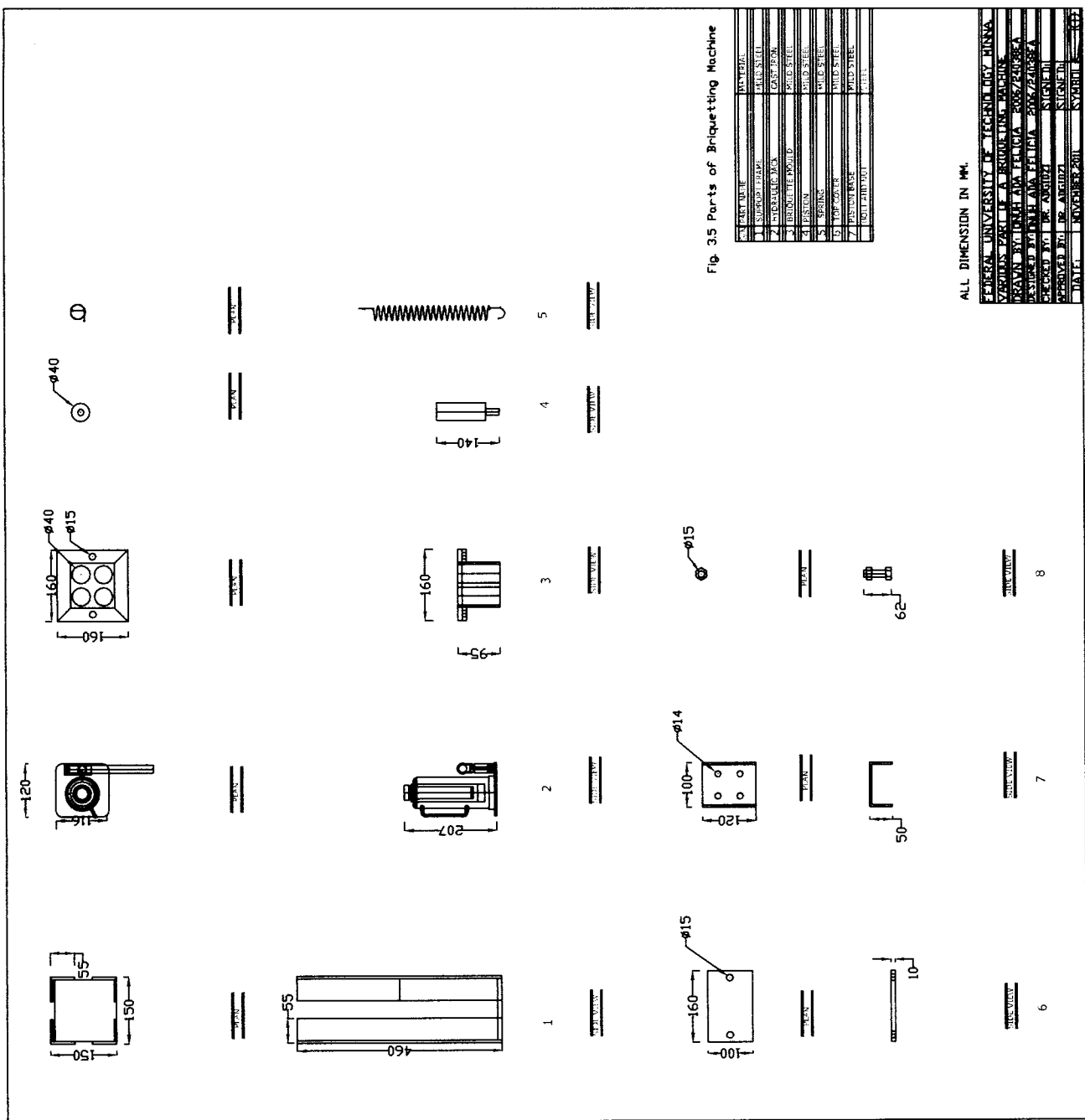

Fig. 3.5 Parts of Briquetting Machine

PART NO.	MATERIAL
1	STEEL
2	STEEL
3	STEEL
4	STEEL
5	STEEL
6	STEEL
7	STEEL
8	STEEL

ALL DIMENSION IN MM.

FEDERAL UNIVERSITY OF TECHNOLOGY MINNA  
 FABRICS PART I & BROOMING MACHINE  
 KAVAN MOJIBAH ANA FALUHA 2008/2009  
 DESIGNED BY: DR. ABDUL SUKMAN  
 APPROVED BY: DR. ABDUL SUKMAN  
 DATE: NOVEMBER 2001

### **3.4.2 Principle of Operation of the Machine**

The agricultural by-products (briquetting materials) are fed into the briquetting chamber with the help of a funnel, the briquetting chamber is covered and screwed with the top cover, and the hydraulic jack is pumped using the hand lever. This jacks the piston up to compress the briquette material through the piston base against the top cover, the jack is pumped continuously until the hand lever can move no more, allow the compressed material to stay for 10 minutes and unscrew the top cover after the 10 minutes. After compaction, the formed briquette is extracted by further jacking up of the hydraulic jack after unscrewing and removing the top cover. The plate below shows a picture of formed briquettes being extracted from the briquetting chamber.

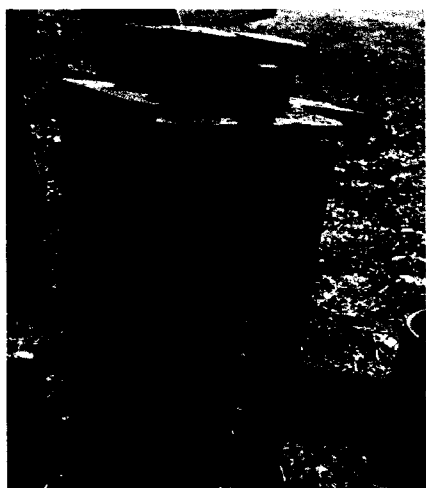

Plate 3.2 Extraction of formed Briquettes

### **3.5 Procedure for Briquetting Rice Husk (Without Binder)**

Rice husk was collected from the national cereal research institute in Bida, Niger state. After collecting, the rice husk was sieved with a 50mm diameter sieve to separate the bran from the husk and the husk was ground to a fine powder in a hammer mill. The fine husk was fed into the briquetting chamber of the hydraulic briquetting machine and compressed. After compaction, the

briquetting chamber was opened after 20 minutes and the formed briquette was collected by gradual application of pressure at the hydraulic jack. The extracted briquette was allowed to dry in an electric oven for 3 hours at a temperature of 105<sup>0</sup>C. After drying, they were packed and conveyed to the laboratory for tests. A pictorial view of the briquettes formed before drying is displayed overleaf.

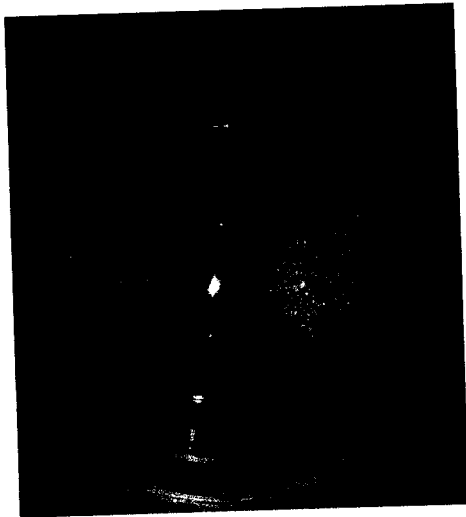

Plate 3.3 Formed Rice husk Briquette (without binder) in the Agric engr. Crop processing lab.

### **3.6 Procedure for Briquetting Rice Husk with binder (cassava starch)**

55.70g of locally made cassava starch was prepared in the Agricultural Engineering departmental laboratory using 50cl of boiling water. It was prepared by mixing the cassava starch with 10cl of cold water to form a paste of light consistency before pouring the boiled water to produce a gel-like liquid called starch which was allowed to cool before use.

After cooling for 30minutes, the cassava starch gel was added to 280g of the already sieved rice husk and kneaded to achieve a uniform mix. The resulting mix known as feed stock was fed into the briquetting chambers and was compressed. After compaction, the top of the chamber was

lifted and the formed briquette was extracted by gradual application of pressure at the hydraulic jack. The extracted briquette was then allowed to dry at 105<sup>0</sup>C in an electric oven for 4 hours, the compressibility and burning efficiency of the briquette produced was tested.

### **3.7 Briquetting Technology Used**

The briquetting technology used in this project is the piston press technology. The biomass material or briquette material is compressed against the cover of the briquetting chamber by a piston moving up and down of which the motion is controlled by a hydraulic jack.

### **3.8 Experimental Tests**

#### **3.8.1 Moisture Content**

##### **3.8.1.1 Apparatus Required**

- Four cans
- Electronic weighing machine
- Fuel samples (briquettes, fuel wood and charcoal)
- Oven

##### **3.8.1.2 Procedure**

The cans were weighed as  $W_{c1}$ ,  $W_{c2}$ ,  $W_{c3}$ , and  $W_{c4}$  fuel samples (rice husk briquette) were placed inside the cans and weighed to determine the initial weight as  $W_{1,1}$ ,  $W_{1,2}$ ,  $W_{1,3}$  and  $W_{1,4}$  the weighed samples were oven dried for four hours at the temperature of 105<sup>0</sup>C after which the materials were reweighed to determine the final weight as  $W_{2,1}$ ,  $W_{2,2}$ ,  $W_{2,3}$  and  $W_{2,4}$ .

Calculation of moisture content:



The percentage of moisture was calculated as follows;

$$M.C = \frac{W_1 - W_2}{W_2 - W_c} \times 100$$

Where

$W_1$  = weight of material before drying

$W_2$  = weight of material after oven drying

$W_c$  = weight of can

The same procedure was used to determine the moisture content of other fuel samples (rice husk briquette with binder, fuel wood and charcoal).

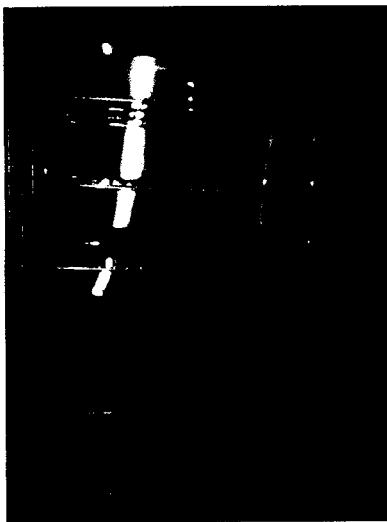

Plate 3.4 Briquettes placed in the oven for drying

### 3.8.2 Compressive Test

This is used to determine the compressive strength of materials or the maximum force or load a material can withstand.

### 3.8.2.1 Materials Used

This test was carried out using the following materials

- Fuel samples (fuel wood, charcoal and the two samples of rice husk briquettes (with and without binder) formed.
- Compressive machine in civil engineering laboratory model C90 and weight 126kg. The machine consists of a hydraulic jack, a load measuring gauge and a dial gauge.
- Fuel wood was sized 40mm × 40mm to be able to enter the compressive machine (Model C90, weight 126kg) in the civil engineering laboratory, Federal university of technology Minna.

The materials were placed in-between two plate of the compressive machine as pressure is been added to the hydraulic jack lever which pushes one of the plate up as it compresses the materials against the second plate until the material starts to fail. The readings on the pressure gauge and dialed gauge were taken and recorded.



Plate 3.5 Manually Operated Compressive test Machine in the Civil Engineering Workshop

### 3.8.3 Burning Test

#### Material Used

- Water bucket
- Cooking pot
- Briquette Samples
- Charcoal
- Fuel wood
- Water
- Stop clock

The cooking pot was weighed using the electric digital weighing balance; water was poured into the cooking pot. The pot with the water was reweighed; the weighed briquette was ignited to boil the water in the pot. A stop clock was used to determine the time it took the water in the cooking pot to boil, and also the burning of the briquette to ash.

The same procedure was used to determine the time it took for the same weight of charcoal and fuel wood to boil the same quantity of water.

### 3.8.4 Determination of Ash Content

The ash content of the fuel samples were determined from the result of the burning test described above;

$$\begin{aligned}\text{Ash content} &= \frac{\text{weight of ash}}{\text{original weight of sample}} \times 100 \\ &= \frac{W_a - W_c}{W_o - W_c} \times 100\end{aligned}$$

Where

$W_a$  = weight of ash + can

$W_c$  = weight of empty can

$W_o$  = original weight of sample + can

### 3.8.5 The Calorific Value

The calorific value of a fuel which is the amount of energy liberated burning a unit mass of the fuel. According to Barnard, 1985 cited in Sulaiman, 2007, the calorific value of wood and agro-residues can be calculated using the following formula which although originally derived for wood can be used for most agro-residues with little alteration. Gross or Higher calorific value

$$(HVC) = 20 \times (1 - A - M) \text{ MJ/kg}$$

Where, A = ash content

M = moisture content of the actual fuel

Net or low calorific value (LCV), takes into account unrecovered energy from water vapour from inherent moisture and from the oxidation of hydrogen content, is sometimes used for references purposes especially in industrial applications. In wood and most agro-residues, the hydrogen content is about 6% by weight on the dry and ash free basis, which means that the above formula would be changed as follows

$$\text{Lower Calorific Value (LCV)} = 18.7 \times (1 - A - M) - 2.5 \times M$$

Where, A = ash content

M = moisture content of the actual fuel (MJ/kg)

For material with low ash content and moisture contents between 10% and 15%, like that in most briquettes from wood and agro-residues, the resulting calorific value are HCV 17-18MJ/kg while LCV range from 15.4MJ/kg to 16.5MJ/kg.

### 3.8.6 Burning Efficiency

The burning test was carried out using the fuel samples to test for burning capacity and burning efficiency, there different method of water boiling test to be carried out, they are percentage heat utilized (PHU), specific fuel consumption (SFC) etc. the burning efficiency was determined using specific fuel consumption (SFC) method.

According to Adekunle J.O (2004)

$$SFC = \frac{\text{mass of briquette burnt}}{\text{mass of water boiled}}$$

$$SFC = \frac{M_i - M_f}{M_w - M_p}$$

Where

$M_i$  = initial mass of briquette before burning (kg)

$M_f$  = final mass of briquette after burning (kg)

$M_w$  = mass of pot and water (kg)

$M_p$  = mass of pot (kg)

### **3.9 Statistical Analysis**

Statistical analysis was carried out on the physical characteristics of the fuel samples using statistical package for social scientist (spss) 17.0.

## CHAPTER FOUR

### 4.0 RESULT AND DISCUSSION

#### 4.1 Result

##### 4.1.1 Dimension of Briquettes

Table 4.1 shows the diameter  $\times$  length respectively of the four briquettes produced in a batch operation for three batches of operation.

Table 4.1 Dimension of Briquettes without binder

Batch no	Diameter $\times$ length(mm)				Mean
	Y <sub>1</sub>	Y <sub>2</sub>	Y <sub>3</sub>	Y <sub>4</sub>	
1	40.00 $\times$ 60.00	40.00 $\times$ 56.00	40.00 $\times$ 53.00	40.00 $\times$ 54.00	40.00 $\times$ 55.75
2	40.00 $\times$ 59.00	40.00 $\times$ 59.00	40.00 $\times$ 60.00	40.00 $\times$ 57.00	40.00 $\times$ 58.75
3	40.00 $\times$ 56.00	40.00 $\times$ 55.00	40.00 $\times$ 57.00	40.00 $\times$ 55.00	40.00 $\times$ 55.75
Mean					40.00 $\times$ 56.75

Table 4.2 Dimension of Briquette with binder

Batch no	Diameter $\times$ length(mm)				Mean
	Y <sub>1</sub>	Y <sub>2</sub>	Y <sub>3</sub>	Y <sub>4</sub>	
1	40.00 $\times$ 56.00	40.00 $\times$ 54.00	40.00 $\times$ 53.00	40.00 $\times$ 54.00	40.00 $\times$ 54.25
2	40.00 $\times$ 51.00	40.00 $\times$ 52.00	40.00 $\times$ 50.00	40.00 $\times$ 51.00	40.00 $\times$ 51.00
3	40.00 $\times$ 45.00	40.00 $\times$ 45.00	40.00 $\times$ 47.00	40.00 $\times$ 46.00	40.00 $\times$ 45.75
Mean					40.00 $\times$ 50.33

#### 4.1.2 Moisture Content

$$W_{c1} = 24.47g$$

$$W_{c2} = 27.79g$$

$$W_{c3} = 25.72g$$

$$W_{c4} = 26.42g$$

Table 4.3 moisture content of the briquettes without binder

Run No.	weight of can+ sample Before drying (g)					weight of can + sample after drying (g)					moisture content (%)				
	$W_{1,1}$	$W_{1,2}$	$W_{1,3}$	$W_{1,4}$	$\bar{W}_1$	$W_{2,1}$	$W_{2,2}$	$W_{2,3}$	$W_{2,4}$	$\bar{W}_2$	$M_1$	$M_2$	$M_3$	$M_4$	$\bar{M}$
1.	96.49	98.68	98.72	99.08	98.24	84.20	87.20	85.77	88.78	86.49	20.58	19.32	21.56	16.52	19.49
2.	85.01	83.87	86.55	86.62	85.51	73.25	73.69	74.33	74.69	73.99	24.11	22.18	25.14	24.72	24.04
3.	86.77	98.50	96.10	97.48	94.71	75.25	87.12	82.43	86.64	82.86	22.69	19.18	24.11	18.00	20.99
4.	98.31	96.76	89.86	95.80	95.18	86.33	83.73	77.48	84.66	83.05	19.37	23.29	23.91	19.13	21.43

Table 4.4 moisture content of samples with binder

Run No.	weight of can+ sample Before drying (g)					weight of can + sample after drying (g)					moisture content (%)				
	$W_{1,1}$	$W_{1,2}$	$W_{1,3}$	$W_{1,4}$	$\bar{W}_1$	$W_{2,1}$	$W_{2,2}$	$W_{2,3}$	$W_{2,4}$	$\bar{W}_2$	$M_1$	$M_2$	$M_3$	$M_4$	$\bar{M}$
1.	79.17	87.76	80.73	86.19	83.46	69.03	76.48	70.19	75.56	72.82	22.76	23.17	23.70	21.63	22.82



2.	75.82	80.85	74.30	79.30	77.57	62.44	66.97	61.44	65.28	64.03	35.24	35.43	36.04	36.08	35.69
3.	77.71	79.92	82.34	80.91	80.22	65.13	66.51	69.97	67.87	67.37	30.94	34.63	27.96	31.46	31.25
4.	80.32	83.12	81.86	80.22	81.38	66.67	69.52	67.21	62.45	66.46	32.35	32.59	35.31	49.32	37.39

Table 4.5 moisture content of charcoal

Run No.	weight of can+ sample Before drying (g)					weight of can + sample after drying (g)					moisture content (%)				
	$W_{1,1}$	$W_{1,2}$	$W_{1,3}$	$W_{1,4}$	$\bar{W}_1$	$W_{2,1}$	$W_{2,2}$	$W_{2,3}$	$W_{2,4}$	$\bar{W}_2$	$M_1$	$M_2$	$M_3$	$M_4$	$\bar{M}$
1.	50.23	50.03	49.99	50.00	50.06	48.92	48.79	48.87	48.89	48.87	5.82	5.18	5.32	4.55	5.22

Table 4.6 moisture content of fuel wood

Run No.	weight of can+ sample Before drying (g)					weight of can + sample after drying (g)					moisture content (%)				
	$W_{1,1}$	$W_{1,2}$	$W_{1,3}$	$W_{1,4}$	$\bar{W}_1$	$W_{2,1}$	$W_{2,2}$	$W_{2,3}$	$W_{2,4}$	$\bar{W}_2$	$M_1$	$M_2$	$M_3$	$M_4$	$\bar{M}$
1.	66.20	66.31	57.58	61.29	62.85	63.20	64.03	55.34	59.06	60.41	8.16	5.82	8.14	6.45	7.14

#### 4.1.3 Compressive strength of fuel samples (rice husk briquettes with and without binders, charcoal and fuel wood)

Table 4.7 Compressive strength of Briquette without binder

Batch no	Compressive strength (KN)					Mean
	$Y_{11}$	$Y_{12}$	$Y_{13}$	$Y_{14}$		
1	35.00	15.00	30.00	20.00		25.00
2	10.00	20.00	25.00	15.00		17.50
3	30.00	25.00	20.00	25.00		25.13
Mean						22.54

Table 4.8 Compressive strength of Briquette with binder

Batch no	Compressive strength (KN)				Mean
	Y <sub>11</sub>	Y <sub>12</sub>	Y <sub>13</sub>	Y <sub>14</sub>	
1	45.00	50.00	55.00	45.00	51.50
2	55.00	55.00	60.00	40.00	57.50
3	75.00	65.00	65.00	60.00	62.50
Mean					57.17

Table 4.9 Compressive strength of Charcoal

Batch no	Compressive strength (KN)				Mean
	Y <sub>11</sub>	Y <sub>12</sub>	Y <sub>13</sub>	Y <sub>14</sub>	
1	20.00	15.00	25.00	20.00	20.00

Table 4.10 Compressive strength of Fuel wood

Batch no	Compressive strength (KN)				Mean
	Y <sub>11</sub>	Y <sub>12</sub>	Y <sub>13</sub>	Y <sub>14</sub>	
1	55.00	60.00	65.00	65.00	61.25

#### 4.1.4 Burning Test

Table 4.11 Burning Efficiency Characteristics of the Samples

Sample	Time interval(mins)	Colour observed	Sample produce
Rice husk briquette	0 – 3:10	yellowish flame, boils water	smoky
without binder	3.10 – 18:19	steady yellow flame	less smoky
	18.19 – 43:11	no flame, complete combustion	less smoky
Rice husk briquette	0 – 1:23	yellowish flame, boils water	highly smoky
with binder	1:23 – 13:35	steady yellow flame	less smoky
	13:35 – 180.13	no flame, complete combustion	less smoky
Charcoal	0 – 30:24	no flame, water boils	no smoke

	30:24 – 41:06	complete combustion	no smoke
Fuel wood	0 – 7:29	yellowish flame, boils water	highly smoky
	7:29 – 74:22	complete combustion	less smoky

**4.1.5 Comparative test between the briquettes formed and charcoal and fuel wood (Using moisture content, ash content, calorific value and burning efficiency)**

Mass of pot used,  $M_p=191.75g$

Amount of water used,  $M_w=20cl$

Table 4.12 Comparative test

Tests	Briquettes without binder	Briquettes with binder	Charcoal	Fuel wood
Weight before burning (g)	86.49	72.82	48.80	64.60
Weight after Burning (g)	43.40	47.91	37.33	63.81
Compressive test (KN)	35.00	63.75	18.33	58.33
Weight of Ash (g)	4.93	7.12	1.66	6.91
Ash content (%)	5.70	9.78	3.40	10.70
Moisture content (%)	19.49	22.82	5.65	7.58

Calorific value	14.96	13.48	19.18	16.34
(MJ/kg)				
Burning Efficiency	71.72	41.10	19.09	1.32
(%)				

#### 4.1.6 Statistical Analysis

Table 4.13 Mean and Standard Deviation of moisture content of the samples without binder

Without binder Descriptive Statistics			
	Mean	Std. Deviation	N
VAR00001	19.4950	2.18500	4
VAR00002	24.0375	1.30855	4
VAR00003	20.9950	2.87753	4
VAR00004	21.4250	2.52610	4

Table 4.14 Mean and Standard Deviation of moisture content of the samples with binder

Moisture content With binder Descriptive Statistics			
	Mean	Std. Deviation	N
VAR00001	22.8150	.87873	4
VAR00002	35.6975	.42602	4
VAR00003	31.2475	2.73183	4
VAR00004	37.3925	8.06418	4

Table 4.15 Mean and Standard Deviation of moisture content of charcoal

Charcoal Descriptive Statistics			
	Mean	Std. Deviation	N
VAR00001	5.2175	.52296	4
VAR00002	5.2175	.52296	4
VAR00003	5.2175	.52296	4
VAR00004	5.2175	.52296	4

Table 4.16 Mean and Standard Deviation of moisture content of fuel wood

<b>Fuel wood Descriptive Statistics</b>			
	Mean	Std. Deviation	N
VAR00001	7.1425	1.19148	4
VAR00002	7.1425	1.19148	4
VAR00003	7.1425	1.19148	4
VAR00004	7.1425	1.19148	4

Table 4.17 Mean and Standard Deviation of compressive strength of briquettes without binder

<b>Compressive strength Without binder Descriptive Statistics</b>			
	Mean	Std. Deviation	N
VAR00001	25.0000	9.12871	4
VAR00002	17.5000	6.45497	4
VAR00003	25.0000	4.08248	4

Table 4.18 Mean and Standard Deviation of compressive strength of briquettes with binder

<b>With binder Descriptive Statistics</b>			
	Mean	Std. Deviation	N
VAR00001	48.7500	4.78714	4
VAR00002	52.5000	8.66025	4
VAR00003	66.2500	6.29153	4

Table 4.19 Mean and Standard Deviation of compressive strength of charcoal

<b>Charcoal Descriptive Statistics</b>			
	Mean	Std. Deviation	N
VAR00001	20.0000	4.08248	4
VAR00002	20.0000	4.08248	4
VAR00003	20.0000	4.08248	4

Table 4.20 Mean and Standard Deviation of compressive strength of fuel wood

Fuel wood Descriptive Statistics			
	Mean	Std. Deviation	N
VAR00001	61.2500	4.78714	4
VAR00002	61.2500	4.78714	4
VAR00003	61.2500	4.78714	4

## 4.2 Discussion of Results

### 4.2.1 Compaction Ratio

The briquetting machine was designed to produce briquettes using selected agricultural waste (waste having high calorific value). The fabricated machine produces four briquettes in a batch operation, the briquettes have the same diameter of 40mm but different height and weight which was as a result of the compaction ratio of the machine, which is based on the type of material, feeding rate and the binding material used.

The ratio of compression of the material made into briquettes was based on the depth of cylinder to the height of briquettes that was compressed. Table 4.21 shows the compaction ratios of the briquettes fed into the machine. The rice husk without binder compaction ratio was 1:1 while that with binder was 2:1.

Table 4.21 Compaction ratio of the briquettes

Raw Materials (mm)	Depth of cylinder (mm)	Depth of compressed briquette (mm)	Compression ratio of briquette

Rice husk with binder	60	60	1:1
Rice husk without binder	60	37	2:1

#### 4.2.2 Firmness of the briquettes

The firmness of the briquettes produced was tested after oven drying them at 105°C for 3-4 hours. The manually operated compressive test machine in the civil engineering departmental workshop was used to determine the compressive strength of the briquettes and that of charcoal and wood fuel. The result of the test as tabulated in table 4.7 shows that rice husk briquettes with binder have the highest compressive strength at 63.75KN and is higher than fuel wood which is 58.33KN. Although, the briquettes without binder are not as high as fuel wood (at 35.00KN), they are higher than charcoal which has a compressive strength of only 18.33KN.

#### 4.2.3 Burning efficiency and Calorific Value

The burning efficiency test was carried out in order to determine the capability of rice husk briquettes to burn longer or faster than charcoal and fuel wood and from the result gotten and tabulated in table 4.5, it can be seen that the rice husk briquettes without binder has the highest burning efficiency from the lot, and during the test, it was observed to burn with a steady yellow flame for 18.19 minutes which is longer than the other fuel sources available, and it was able to burn to ashes in less than an hour.

Charcoal on the other hand, has the highest calorific value at 19.18MJ/Kg which can be attributed to its low moisture content. It has the lowest moisture content at 5.65% followed by fuel wood which has a moisture content of 7.58% and the lowest burning efficiency at 1.32%.

### 4.3 Material Selection

The choice of a particular material depends on the materials that meet design specifications which were obtained from calculations, the following factors were taken into consideration when selecting the materials;

- **Material properties:** The yield strength of the material selected must correspond to or be greater than that used in the design analysis and calculations.
- **Deteriorative properties:** Such as resistance to oxidation, corrosion or weathering were also considered and are taking care of by painting of the finished work.
- **Manufacturing characteristics:** This includes the material ability to be welded and machined, as most joints are to be made by welding.
- **Cost:** Material cost and manufacturing cost were considered. Relatively cheap materials when compared to other engineering materials that meet the design constraints were considered during selection.
- **Aesthetic properties:** Ability to accept special finishes such as painting.

Considering these parameters listed above and the design calculations done, mild steel plates were used for the base plate, pressure plate, top plate and other components were made from mild steel.



#### 4.4 Material and Labour cost

The cost of a component is usually influenced by its component design, manufacturing techniques and method and the material used in making the component. The cost of fabrication of the machine is grouped into three, namely:

- i. Material cost
- ii. Labour cost
- iii. Overhead cost

##### 4.4.1 Material cost

The material cost is tabulated below.

Table 4.22 Breakdown of the material cost

s/no	Material/Part	Quantity	Unit Price ₦	Amount ₦
1.	75× 75 × 5mm Angle bar	4	300	1200
2.	“C” sectioned bar	2	500	1000
3.	40mm pipe, 95mm in length	4	125	500
4.	38.5mm hollow shaft, 100mm in length.	4	300	1200
5.	15mm shaft, 120mm in length.	4	200	800
6.	Bolt & nuts	2	350	700
7.	Spring	1	500	500
8.	10 tons hydraulic jack	1	3500	3500
9.	Flat bar	1	1200	1200

10. 6mm flat plate	1	300	300
Total			10900

#### 4.4.2 Labour cost

Labour cost involves the cost of the machining, cutting, welding and painting. It is taken as 20% of the material cost.

Therefore,

$$\text{Labour cost} = \frac{20}{100} \times 10900 = \text{N}2180$$

#### 4.4.3 Overhead cost

The overhead cost includes cost incurred during construction such as transportation, lubrication, as well as other consumables. It is taken at 20% of the material cost.

$$\text{Overhead cost} = \frac{20}{100} \times 10900 = \text{N}2180$$

$$\text{Therefore the total cost} = 10900 + 2180 + 2180 = \text{N}15260$$

#### 4.4.4 Cost of Producing Briquette

The briquettes were produced using the fabricated briquetting machine, sawdust and gum Arabic as binder. The machine produces four briquettes in a batch production within 30 minutes, in an hour; the machine will produce eight briquettes.

If the briquetting machine works for 10 hours in a day, it will produce a total of  $8 \times 10 = 80$  briquettes/day. If the machine has a life span of 10 years (120 months), therefore, about =

$$\frac{15260}{120} = \text{₦}127.17 \text{ of the machine is consumed every month}$$

Table 4.8 shows the list, quantity and cost of the inputs needed for the production of briquettes using the fabricated briquetting machine for a month (30 days)

Table 4.8 Breakdown of production cost of briquette/month

INPUTS	QUANTITY	UNIT COST (₦)	COSTS (₦)
<b>Materials:</b>			
Rice husk	10 bags	200	2000.00
Cassava starch	7.5 mudus	700	5250.00
Equipment (Briquetting machine)	1 machine	15260	127.17
Direct Labour	A worker	10000	10000.00
Overheads			5000.00
<b>TOTAL COST OF PRODUCTION</b>			<b>22377.17</b>

Therefore

$$\text{Total cost of production per month} = \text{₦}22377.17$$

Total cost of producing 80 briquettes per day =  $\frac{22377.17}{30} = \text{₦}745.91$

Total cost of producing a briquette =  $\frac{745.91}{80} = \text{₦}9.32$

Therefore, price tag for a briquette is **₦10**

## CHAPTER FIVE

### 5.0 Conclusion and Recommendation.

#### 5.1 Conclusion

This project work presents the design and performance analysis of a hydraulically operated briquette making machine which was constructed in minna, Niger state and tested in the agric and bio-resources departmental laboratory, federal university of technology, Minna, Niger state.

The design and construction was carried out to suit selected agricultural waste with high calorific values and loose nature, and it was tested on rice husk with and without the use of binder (cassava starch).

The design was carried out with due considerations of the major factors as applied to the operational characteristics and cost effectiveness. The design proves that with a 10 ton hydraulic jack, which is a high source of pressure, the machine is able to compact a wide range of agricultural waste which will lead to an increase in their calorific value and burning efficiency as fuel sources.

Analysis carried out on the briquettes showed that the machine was effective in the compression of the briquetting materials which increased the energy intensity of the agricultural waste product used.

From the result gotten and the statistical analysis carried out, the aim and objective of the project can be said to have been achieved.

## 5.2 Recommendation.

For further work and research to be carried out on this project work, I therefore recommend that work and research be done on the following areas:

- i. It is recommended that further research be carried out to bring about new and improved designs on methods used for briquetting agricultural waste.
- ii. That a different sizes and shape of briquettes should be considered to get better surface area and therefore make the drying process faster.
- iii. That other source of powering the machine should be explored and considered.
- iv. And other types of binders be tried when briquetting rice husk.

## REFERENCES

- Adegoke, C. O. and Mohammed, T. I, (2002); Investigation of sawdust briquettes as high grade fuel, West Indian Journal of Engineering. 25 (1): Pg 1-8
- Adegoke, L.O. 1999, Investigation into the briquetting of sawdust. The Nigerian Engineer 24(3):1-10
- Akinbami J.F.K. 2001. Renewable energy resources and technologies in Nigeria: Present situation, future prospects and policy framework. Mitigation and Adaptation Strategies for Global Change 6:155-181.
- Barnard C. 1985. The use of agricultural residues as fuel. AMBIO; XIV: 4-5
- Ehab E.S. (2004).Renewable Energy in Agriculture in Egypt, Technological Fundamentals of Briquetting Cotton Stalks as a Biofuel.
- Grigorion, A.H. 2003. Waste paper-wood composites bonded with isocyanate. Wood science technology 37 (1):79-89.
- Kocaman F. M, Razel M. A. P, Johnyver A. M, Sugar R. A. H, & Arnulfo B. O,(2008). Design and development of charcoal briquetting machine. Department of Agricultural Engineering, College of Engineering and Computing, University of Southern Mindanao, Kabacan, Cotabato.  
Available at: <http://region10.dost.gov.ph/technologies/English/charcoal.htm>  
[Accessed on 8<sup>th</sup> of August, 2009]
- Khurmi, R. S. and Gupta, J. K, (2008). A textbook of Machine design- 14<sup>th</sup> Ed. Eurasia Publishing House (P) Ltd., Ram Nagar. New Delhi
- Microsoft Encarta (2009)

- Microsoft Encyclopaedia (2008)
- Ogunrinde E.A: (2007) Development and performance evaluation of Briquettes from agricultural by-products. A final year undergraduate project Report, Department of Agricultural and Bioresource Engineering, Federal University of Technology, Minna.
- Prokhorov W, (1982). Density Equation of Bio-Coal Briquettes and Quantity of Maize Cob in Phitsanulok, Thailand. Department of Mechanical Engineering, Engineering Faculty, Biomass Energy Research Unit, Naresuan University, Phitsanulok, Thailand  
[online] American Journal of Applied Sciences  
Available at: <http://www.scipub.org/fulltext/ajas/ajas412995-998.pdf>.  
[Accessed on 2<sup>nd</sup> of October, 2009]
- Rajput, R.K, (2006) Strength of Materials [Mechanics of Solids] 5<sup>th</sup> Ed S. Chand and company Ltd Ram Nagar New Delhi.
- Surharno L. M, (1979) Applied strength of materials – 4<sup>th</sup> Ed. Prentice – Hall of India, Private Limited. New Delhi.
- Sulaiman H. D: (2007) Development and Performance Evaluation of Briquettes Produced from Agricultural By-Products. A final year undergraduate project Report, Department of Agricultural and Bioresource Engineering, Federal University of Technology, Minna.
- Sustainable Energy. (2003). Briquetting: An answer to deforestation, health problems, Unemployment and Reforestation in developing communities.[online]  
[www.sustainableresources.org](http://www.sustainableresources.org) • email: [info@sustainableresources.org](mailto:info@sustainableresources.org)
- Wamukonya L. and B. Jenkins (1995) Durability and relaxation of sawdust and wheat - straw briquettes as possible fuels for Kenya. Biomass and Bioenergy 8 (3): 175-179.



- Yuksel I, Lasheva V, Tz. T, Josifov N, (2008). Silica products from rice hulls. Journal of the University of Chemical Technology and Metallurgy, pg. 257-261. University of Chemical Technology and Metallurgy 8 Kl. Ohridski, 1756 Sofia, Bulgaria
- Yousif A. A and Ahmed E. A., (2006). Experimental evaluation of a conical-screw briquetting machine for the briquetting of carbonized cotton stalks in Sudan [online]. Journal of Engineering Science and Technology Vol. 1, No. 2 School of Engineering, Taylor's University College.
- <http://www.bpre.gov.ph/PHIndustry/cassava.htm>
- <http://www.thaisumi.com/charcoalbriquetting.aspx>
- [www.wikipedia.com](http://www.wikipedia.com)