

# **DESIGN AND CONSTRUCTION OF A BATTERY-LOW VOLTAGE DETECTOR**

**BY**

**LOLADE AHMED OYEBANJI**

**MATRICULATION NUMBER**

**2005/22086EE**

**A PROJECT SUBMITTED TO THE DEPARTMENT OF ELECTRICAL AND  
COMPUTER ENGINEERING IN PARTIAL FULFILLMENT OF THE REQUIREMENT  
IN FOR THE AWARD OF BACHELOR OF ENGINEERING (B.ENG) DEGREE IN  
ELECTRICAL / COMPUTER ENGINEERING FEDERAL UNIVERSITY OF**

**TECHNOLOGY, MINNA,**

**NIGER STATE, NIGERIA**

**NOVEMBER, 2010**

## **DEDICATION**

This project is dedicated to my mum who worked tirelessly to single-handedly train everyone under her care, children or not. May Allah continue to bless her.

# DECLARATION

I, Ololade Ahmed Oyebanji, declare that this work was done by me and has never been presented elsewhere for the award of a degree. I hereby relinquish the copyright to the Federal University of Technology, Minna.

OLOLADE AHMED OYEBANJI

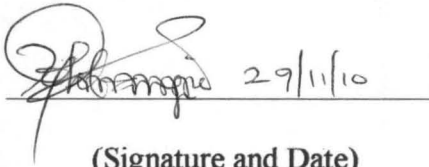

(Name of student)

 29/11/10

(Signature and Date)

ENGR. A. G. RAJI

(Name of H.O.D)

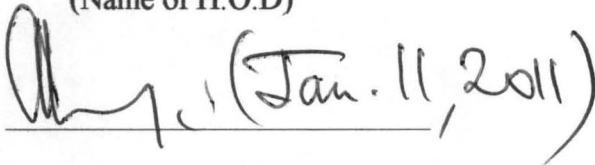
 (Jan. 11, 2011)

(Signature and Date)

MR. NATHANIEL SALAWU

(Name of Supervisor)

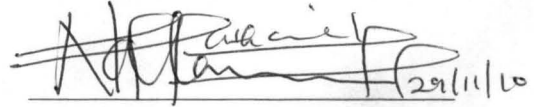
 29/11/10

(Signature and Date)

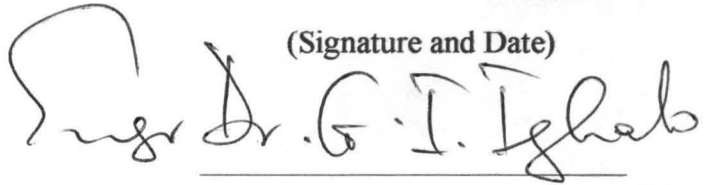

(Name of External Examiner)

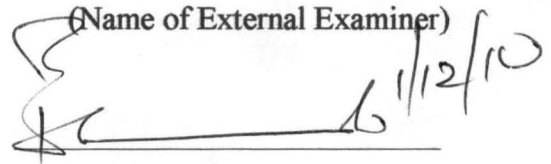
 11/12/10

(Signature and Date)

## ACKNOWLEDGEMENT

As always, special thanks to Almighty Allah, for his mercies and support.

This work was brought to conclusion by the direction and guidance of the patient, intelligent, extremely calm and confident mind of Mr. Nathaniel Salawu, my supervisor. That guidance will continue to reverberate after this whole degree program. Also, I wish to thank my assistant supervisor, Mallam Ishayku for his technical advice and assistance given in areas where I am weak.

I cannot forget to appreciate the efforts of all the entire staffs of Electrical and Computer Engineering department, for both their collective and individual contributions to make this course a realizable one.

I wish to thank my group members Igwe, Mohammed, Shade, Yayock and Bilya for their co-operation and assistance in various areas. Lastly, my closest friends in the department Olisa, Tunji, and Sikiru, for all their efforts. Insha Allah, all our futures are filled with blessings and mercies from the Almighty.

## ABSTRACT

This project, "Battery Low Voltage Detector", was designed strictly to give alerts for batteries. The main target is to be connected to a battery without adding extremely much load and perform its prescribed duty accurately. As the battery voltage drops below the set point, the LED will light and a periodic beeping will come from the speaker. That is its duty. The set point can be set manually to any desired voltage level, as long as it is below the voltage value of the monitored battery. Since batteries must be connected to a load, the circuit was designed with choice components that take negligible current from the batteries. It has an idle current of about 6mA and a low voltage warning current of 15mA. These components also make the design relatively inexpensive, compact and light in weight. It is also easy to use by non-technical individuals.

# TABLE OF CONTENTS

<b>Contents</b>	<b>Pages</b>
Title Page.....	i
Dedication.....	ii
Declaration.....	iii
Acknowledgement .....	iv
Abstract.....	v
Table of Contents.....	vi
List of Figures.....	ix
List of tables.....	x
<b>Chapter One: General Introduction</b>	
1.0 Introduction.....	1
1.1 Expository Introduction.....	1
1.2 Objectives.....	2
1.3 Methodology.....	3
1.4 Scopes of Work.....	4

1.5	Sources of Materials.....	4
1.6	Constraints to Achievable Performance.....	4
1.7	Involvement of Others in/out of the Department.....	4

## **Chapter Two: Historical Background/Literature Review**

2.0	Literature Review/Theoretical Background.....	5
2.1	Background of Study.....	5
2.2	What to Monitor.....	6
2.3	How to Monitor.....	6
2.4	Literature Review on Batteries.....	9
2.5	Review on Alarms.....	10

## **Chapter Three: Design and Construction**

3.1	Principles of Operation.....	19
3.2	Regulating and Varying Unit.....	19
3.2.1	Voltage Regulator.....	20
3.2.2	Resistors.....	22
3.3	Comparison and Switching Unit.....	24
3.3.1	Comparators.....	24

3.3.2	Transistors.....	25
3.3.3	BJT Switch Calculation.....	26
3.4	Timing and Load Unit.....	28
3.4.1	Light Emitting Diode (LED).....	28
3.4.2	Timers.....	29
3.4.3	Calculation on Timers.....	30
3.5	Diodes.....	32
3.6	Capacitors.....	32
3.7	Construction.....	33
3.7.1	Casing.....	33

#### **Chapter Four: Test, Result and Discussion of Results**

4.1	Test and Result.....	37
4.2	Discussion of Result.....	38
4.3	Limitation.....	38
4.4	Troubleshooting.....	38

#### **Chapter Five: Conclusion**

5.1	Summary.....	39
-----	--------------	----



5.2	Results Obtained.....	39
5.3	Problems Encountered.....	39
	References.....	

## LIST OF FIGURES

1.1	Block Diagram.....	16
2.1	Discharge curve shape for a Ni-MH battery.....	17
3.1	Regulating and Varying Unit.....	19
3.2	A voltage regulator.....	20
3.3	Circuit of a Voltage Regulator.....	21
3.4	Resistors with Colors.....	22
3.5	A Variable Resistor.....	24
3.6	Comparison and Switching Unit.....	24
3.7	An LM339 Quad Comparator.....	25
3.8	A BJT Transistor.....	26
3.9	Timing Unit.....	29
3.10	LED.....	29
3.11	A 555 Timer.....	30

3.12	A diode.....	33
3.13	A Capacitor.....	34
3.14	Circuit diagram of the complete design.....	35

## **LIST OF TABLES**

3.1	Table of resistor color codes.....	23
3.2	Table of Components of the design.....	36
4.1	Table of Result.....	37

# CHAPTER ONE

## 1.0

## INTRODUCTION

### 1.1 EXPOSITORY INTRODUCTION

Our contribution to society is sometimes fuelled by personal experience, complimented by the knowledge of a particular field of study. To ensure the continuity of operation of any system supplied power by the transmission and distribution body, most devices are alternatively powered on battery. So in our life, we must have experienced frustration one time or the other when using battery-backed device or systems. A battery is and has become a vital element of any battery-backed system. In many cases the battery is even more expensive than the system it is backing up. Today's expensive heavy duty batteries are too valuable. Hence we need to adopt all practical measure to conserve battery life. A 12 V rechargeable lead-acid battery, for instance, should be operated not lower than 10.1 V, as per manufacturer's datasheets. Anything below 10 V and it can be said to be deeply discharged and a single event of discharge can cause lots of negative effects. A very common effect is this scenario; a battery slated to last for, say nine months on optimum performance of four hours before exhaustion/discharging could suddenly be found to have a drastic optimum performance of one and a half hours before discharging, just after three months of usage. This phenomenon is very common to portable devices such as laptops, mobile phones and common household appliances like rechargeable lamp. In general, it is virtually common to all devices, machines and systems, whether small or large, that runs on battery.

It is therefore necessary for all concerned to monitor the charge level of the batteries continuously. But in practice, many of the battery users are unable to do so because of non-availability of reasonably priced monitoring equipment, among other reasons. The circuit idea

presented in this project work will fill this void by presenting a circuit that will monitor the discharge level of batteries, mainly households', continuously.

## **1.2 OBJECTIVE**

It is therefore an object of this design to provide a circuit for reliably detecting a low voltage level of a battery because of the disastrous effect of a series event of discharge and what it could cause to a battery, as expensive as they have become. It is a further object of this design to provide a circuit simple enough to use because a large percentage of battery consumers are common and ordinary household users with little or no technical knowledge on how to go about caring for their battery. It is a further object of this design to provide a circuit that is relatively inexpensive because some standard low-battery detecting equipments are pretty hard to come by hence, expensive and unaffordable by some people.

This project is designed to show a voltage level which indicates a low state of a battery. The indication is in the form of audio and visual. It basically involves comparing the battery voltage with the reference voltage. If the battery voltage falls below a set point, the display alerts will be set off calmly but gets erratic as the level of the voltage decreases.

A major thing to keep in mind along with the objective was to first of all design a simple and compact circuit that reduces the requirement of the human attention by 85 per cent, and then secondly to make a design with a highly accurate and sophisticated and inexpensive method so it is a further and general object of this project to design a circuit that provide reliable detection on the low voltage level of a battery without materially increasing the load to which the battery is subjected and also without increasing the need of activity of an individual.

### 1.3 METHODOLOGY

Input from the battery is applied to a comparator through a regulator, for one input leg, and through a variable resistor, for the other input leg. The output of the comparator goes to a transistor which is acting as a switch. The output of this transistor is passed along to two timers and a LED. These two timer passes along the signals generated to a buzzer. It is recommended that at the point when the buzzer sounds, the battery should be changed. The circuit is powered by the battery under observation. Presently with the components being used, it takes about 6mA in idle current from the battery and an approximate of 15mA when making the alerts. A figure of the block diagram of the operation of the circuit is shown in fig. 1.3, where it is seen from a glance that the battery being monitored also supplies power to all the components in the design.

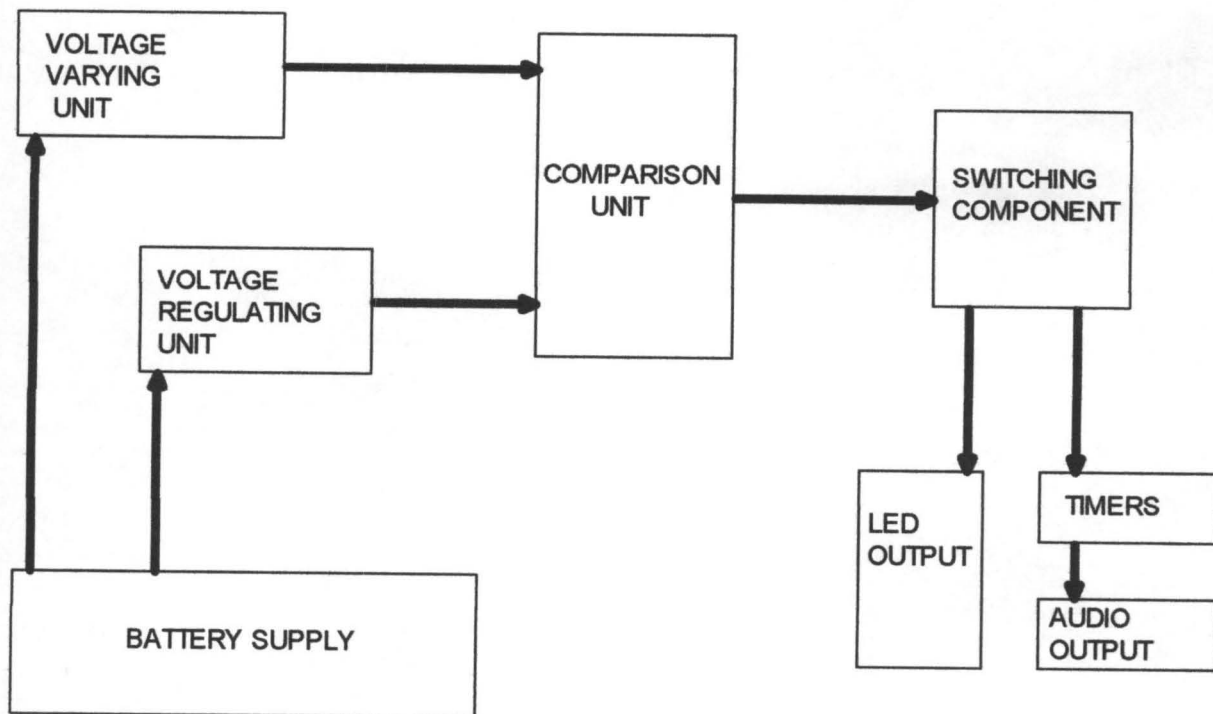

Fig. 1.1 Block diagram of the circuit.

The project was first simulated electronically. The simulation was necessary to test different components and weigh the merits and demerits of those particular components against its equivalents with regards to current drawn in idle and active mode. After the whole process of simulation, the circuit was implemented on a bread board. Further components were changed at this stage. After achieving a stable and favorable condition, the Vero board part was implemented.

#### **1.4 SCOPE OF WORK**

The scope of work of the circuit is to monitor the discharge level of a battery at a particular set point. It is not concerned with overcharging.

#### **1.5 SOURCE OF MATERIALS**

Reputable source of materials used so far include;

Library of Electrical and Electronic Engineering (Lib E) Digital Library CD-ROM by DTEKtron, data books on individual components and equivalents, and, the World Wide Web.

#### **1.6 CONSTRAINTS TO ACHIEVABLE PERFORMANCE**

The most notable constraint to achievable performance was the choice of components used. Some components had a hand in quickly discharging the battery under observation. Some other components, however, made the circuit too large. To make the circuit simple, relatively inexpensive, compact and not drawing huge current that would quickly discharge the battery, the choice of components used reflects these objectives.

#### **1.7 INVOLVEMENT OF OTHERS IN/OUT OF THE DEPARTMENT**

The Project supervisor and the Assistant supervisor have been greatly involved. The staff of electrical department has helped also by providing one or two materials for cross referencing.

## CHAPTER TWO

### 2.0 LITERATURE REVIEW/THEORETICAL BACKGROUND

#### 2.1 BACKGROUND OF STUDY

The sophistication and uses of electrical devices have increased dramatically. Consumer items having electrical components are ubiquitous in communications, computing, entertainment, transportation, etc. Numerous people rely upon or have grown accustomed to usage of electrical devices for business, education, or for other needs. Electronic devices are increasingly portable to accommodate these needs during travels from home or the workplace. The sophistication and capabilities of power supplies for such devices have also improved to meet the requirements of the electronic consumer devices. For example, cost, size, and capacity are some product characteristics which have been improved for the portable power supplies. In addition, portable power supplies are being used in additional applications. For example, there is increased interest upon usage of alternative energy sources including electrical energy for an expanding number of applications, such as transportation applications, solar applications, backup battery system popularly known as uninterruptible power supply or UPS, etc.

The typical dilemma of a backup battery system user is whether to rely on the guarantees of a battery supplier with regard to product performance, or to independently monitor battery status to ensure reliable backup power and voltage across the terminals of the battery not being allowed to drop below a certain minimum voltage as the moment that happens, the battery should be put on charge because constant drop to that level is very likely to cause fatal battery damage. Some batteries are very expensive, even than the systems they are backing up. So it is necessary to avoid a voltage drop to that level. This dilemma has created a vague sense of mistrust between battery suppliers and end users. More and more end-user decision makers, however, are leaning

toward the use of monitoring devices to guarantee the power they need, when they need it, and to guarantee the sustenance of their battery life. This trend can have positive benefits for all concerned, as end users become better satisfied with the lifespan of their batteries and are better educated about the values and uses of monitoring technology. Once an end user has decided that monitoring is a good decision, two questions arise: what to monitor and how to monitor it. These questions have become very important issues in today's battery user marketplace.

## **2.2 WHAT TO MONITOR**

There are various entities/factors that can be monitored. There are also many reasons for monitoring. Some of the entities and reasons are

- Monitoring the conditions of individual cells which make up the battery.
- Providing information on the State of Charge (SOC) of the battery.
- Providing information on the State of Health (SOH) of the battery, etc.

## **2.3 HOW TO MONITOR**

### **USING DISCHARGE CURVE**

Exemplary portable power supplies such as batteries store electrical energy given out as voltages [1]. Batteries fluctuate in voltage when being used but a rough average gives a pretty clear indication of the remaining charge in a battery since it is beneficial to know the state of charge of the batteries during operation of the electrical devices. Each battery has a characteristic discharge curve of voltage compared to capacity [1]. Armed with a discharge curve for your typical battery usage and your battery, you can pretty accurately gauge the remaining time of operation. However, challenges are presented with respect to determining state of charge information with respect to some battery cell chemistries. In one example, it may be difficult to monitor battery



cells which have a substantially flat discharge profile. Typical discharge curve shape for a NiMH battery is roughly S-shaped [2] as shown in fig.2.1.

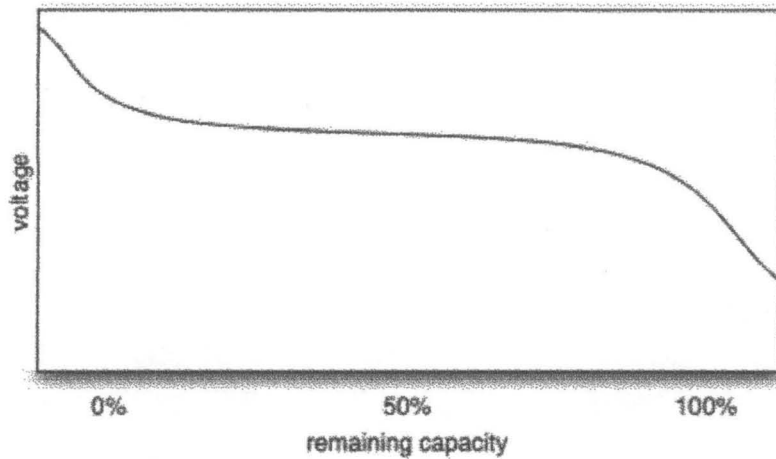

Fig. 2.1 Discharge curve shape for a Ni-MH battery.

#### **USING A HYDROMETER TO MONITOR**

With wet cell batteries the most accurate determination of the state of charge is with a hydrometer. The hydrometer determines the amount of sulphuric acid in the electrolyte which translates to the state of charge of the battery. Because this concentration varies with temperature the measurement has to be carried out at the standard temperature of 80 degrees F or calculations have to be made to correct the reading to the actual temperature. A fully charged cell has a specific gravity of around 1.27 to 1.28 depending on the battery manufacturer. A discharged cell will have a specific gravity of about 1.1. For sealed batteries it is not possible to do this procedure and anyway it is not one that can be done practically on a daily basis even for wet cell batteries. It is obvious that another method is needed for day to day operations [3].

## USING A VOLTMETER TO MONITOR

A voltmeter can be used to get a quick snapshot of the state of charge of any battery type. A fully charged 12 volt battery will have an open circuit voltage of around 12.6 volts depending on the type, and a battery is considered fully discharged when the voltage drops to 10.5 volts at the 20 hour discharge rate. A 50% state of charge is around 12.2 volts. The problem with using a voltmeter to measure state of charge is that the battery has to be at rest for 24 hours to get an accurate reading. This precludes using the method for day to day operations. When the voltmeter is used without waiting 24 hours a false reading is produced by the surface charge on the plates. Although the voltmeter appears to give an indication of state of charge it really doesn't do it accurately enough for most purposes [4].

. In any case, it would be impractical to install a meter and keep watching the battery voltage.

Hence, the need arose for electronic circuits that can keep a continuous watch on the battery voltage and either give an audio/visual alarm, or switch off the load on the battery, or switch on a charger that's connected to it as soon as the battery voltage drops below a predetermined voltage. Such interesting circuits are called monitoring circuits. The primary requisite of all monitoring circuits is that they themselves should not draw excessive power from the battery and drain it off completely / discharge and over discharge it.

By connecting the terminals of a battery to the two inputs of a comparator (varying one input and making the other input a fixed value), and using the correct combinations of resistors and capacitors, a good signal value can be outputted by the comparator. The fixed value can be obtained with the aid of a voltage regulator. Since the comparator will be outputting two different voltage level, an electronic switch will be needed to allow only the appropriate signal to

Batteries have been in existence since early 1800 since the invention of the first voltaic pile by Alessandro Volt. According to a 2005 estimate, the worldwide battery industry generates US\$ 48 billion in sales each year with 6% annual growth [5]. Batteries have become the vital element of any battery-backed system. In many cases the battery is even more expensive than the system it is backing up. A good example is the largest battery in the world which is in Fairbanks, Alaska, composed of Nickel-Cadmium cell. It is by far the most expensive battery in the world. It was made by ABB, a global power and automation group. It includes, among other things, a protection, control and monitoring devices [6]. One other popular type of battery is the lead-acid battery (Batteries are usually named based on the metal used to make either the electrodes or the electrolyte). A lithium-ion battery (LI-on) has a lithium anode, a zinc-carbon battery has a zinc anode, and a nickel-metal hydride battery (Ni-MH) or a nickel-cadmium battery (Ni-CD) has a hydrogen-absorbing alloy for the anode). It is used almost everywhere and in most heavy-duty systems most popularly in the automotive industry. The nominal voltage of a battery depends on the number of cells wired in series [1]. The Fairbanks battery has a total of 13,760 cells [7]. Each battery cell in a lead acid battery contributes a nominal voltage of 2 volts, so a 12 volts battery would contain 6 cells wired in series. According to most manufacturers' datasheet, most 12 volts battery should be operated within 10.1 volt and 13.8 volt. When the battery discharges below 10 volts, it can be deeply discharged and a single event of discharge can greatly affect the charge-holding capacity of a battery by 15% to 20% [1]. In other words, the battery begins to die quicker than expected. Lithium-ion (Li-ion) batteries is another type of battery and they are growing in

pass through. This signal will then be passed onto the alert consoles which are the LEDs and the buzzer, through the aid of timers that will regulate the sound.

popularity as energy storage reservoirs for high-voltage energy, industrial and automotive applications, such as wind turbines, photo-voltaic cells, and hybrid electric vehicles, and this has spurred demand for safer, higher performing battery monitoring and protection systems. Analog Devices, Inc., a global leader in high-performance semiconductors for signal-processing applications, addressed the requirements of Li-ion battery users with a Li-ion battery monitoring and protection system that integrates all necessary components, including voltage and current measurement, signal isolation and safety monitoring. Compared to Ni-MH (nickel-metal hydride) batteries, Li-ion batteries have a better energy-to-weight ratio, offer more efficient storage capacity over multiple charge-discharge cycles, and suffer less charge leakage when not in use. And unlike Ni-MH batteries traditionally used in high-voltage applications, battery stacks using Li-ion technology can comprise a large number of individual cells totaling hundreds of volts. Each cell must be properly monitored and balanced to ensure user safety, improve battery performance and extend battery life. The above mentioned Li-ion battery monitoring and protection system performs these functions while also allowing replacement of costly discrete components, decrease power consumption and reduce system space. Most portable device these days uses Lithium-Ion batteries. Lithium is the lightest metal and the one with the highest stored (“potential”) electrochemical energy. These qualities, along with the fact they do not contain poisonous metals (such as cadmium) make lithium-based batteries the most widely used to power portable devices such as laptops. Hence, Li-ion batteries must be treated with respect [8]. This brings us to detectors/alarms specially made to monitor batteries.

## **2.5 REVIEW OF ALARM SYSTEMS**

Alarms and detectors are synonymous. They detect certain conditions and then give alerts. They have been in existence since man lived in caves. The first alarm that was recorded in history was

an alarm clock [9]. Various types of alarms have been produced and today, are currently in use in commercial and household environments. Such alarm circuits are typically used to detect smoke and/or excess heat, to detect the presence of intruders or to detect other emergency conditions which necessitate the sounding of an alarm to alert the proper parties of an emergency condition. Electronic and automated system needs an alarm for different reasons and for different section of the system most especially the power sections. Talking about power, almost every systems ranging from solar to automotive to even alarms themselves use battery because they cannot depend on the availability of the commercial power supply. These batteries all need monitoring; monitoring to know when it is running down, when it needs to be charged, or at what set point it needed to be put off or excused. A low battery alarm was easily and expectedly created to satisfy this need. Then it was integrated into most of the systems, even right from productions. Car batteries, UPS, to mention a few, all come with low-battery detectors/alarms. But for a long time, alarms weren't that easily and readily integrated like that. For a long time, there was some kind of turbulence caused by what can be termed "alarm-mania". In those days of large chemical, refining, power generation, and other processing plants, for instance, before the acceptance of semi-conductors, the plants required the use of a control system. These control systems often required a control room. In the early days of control rooms, they utilized what were referred to as "panel boards" which were loaded with control instruments and indicators. Alarms were added to alert the operator to a condition that was about to exceed a design limit, or had already exceeded a design limit. Alarms were indicated to the operator by annunciation horns, and lights of different colors. (For instance, green lights meant OK, Yellow meant not OK, and Red meant BAD). Thus, in the early days of panel board systems, alarms were regulated by both real estate, and cost. In essence, they were limited by the amount of available board space, and the cost of

running wiring, and hooking up an annunciation (horn), indicator (light) and switches to flip to acknowledge, and clear a resolved alarm. It was often the case that if you wanted a new alarm, you had to decide which old one to give up, just because of space. As technology developed, control systems were tasked to advance to higher degrees. In the days of the panel boards, a special kind of engineer was required to understand a combination of the electronic equipment associated with process measurement and control, the control algorithms necessary to control the process. Today, engineers could now control the process without having to understand the equipment necessary to perform the control functions. Panel boards were no longer required, because all of the information that once came across analog instruments could be digitized, stuffed into a computer or a single circuit or IC, and manipulated to achieve the same control actions once performed with amplifiers and potentiometers.

As a side effect, that also meant that alarms were easy and cheap to configure and deploy. You simply sat down, create an alarm and set it to active. The unintended result was that soon people alarmed everything. Recognizing that alarms were becoming a problem, industrial control system users banded together and formed the Alarm Management Task Force, which was a customer advisory board in 1990. The focus of this work was addressing the complex human-system interaction and factors that influence successful performance for process operators. Automation solutions have often been developed without consideration of the human that needs to interact with the solution. Alarms are intended to improve situation awareness for the operator but a poorly configured alarm system does not achieve this goal. The fundamental purpose of alarm annunciation is to alert the operator to deviations from normal operating conditions, i.e. abnormal operating situations. The ultimate objective is to prevent, or at least minimize, physical and economic loss through user/operator intervention in response to the condition that was

alarmed. A key factor in operator response effectiveness is the speed and accuracy with which the user/operator can identify the alarms that require immediate action. In all cases of major equipment failure, startups, and shutdowns, the user/operator must search alarm annunciation displays and analyze which alarms are significant. This wastes valuable time when the user/operator needs to make important operating decisions and take swift action. If the resultant flood of alarms becomes too great for the user to comprehend, then the basic need for alarm has failed as a system that allows the operator/user to respond quickly and accurately to the alarms that require immediate action. In such cases, the user/operator has virtually no chance to minimize, let alone prevent, a significant loss.

Since humans can only do one thing at a time and can pay attention to a limited number of things at a time, there needs to be a way to ensure that alarms are presented at a rate that can be assimilated by a human operator, particularly when the plant/monitored object is in an unusual condition. Alarms also need to be capable of directing the operator's attention to the most important problem that he or she needs to act upon, using a priority to indicate degree of importance or rank, for instance. In much the same way, if alarms were unprioritized, the important ones can be mixed in with lower value nuisance ones.

Alarm management became more and more necessary as the complexity and size of manufacturing systems increased. A lot of the need for alarm management also arises because alarms can be configured at nearly zero incremental cost, whereas in the past on physical control panel systems, in plants, that consisted of individual instruments, each alarm required expenditure and control panel real estate, so much more thought, cost and energy usually went into the need for an alarm [10]. Numerous disasters have established a clear need for alarm management. Examples of such incidences are the Three Mile Island and the Chernobyl accident



[11]. Those are large scale disasters involving large factories. On a smaller scale, such disaster involves the battery backing-up or powering a system getting damaged, especially before its time, most likely portable or home used. A battery utilized in such systems should be of extremely long life so the battery should not be repeatedly changed in order to ensure the continuous operation of the system. To ensure long life of the battery, the methods are plentiful; ensuring a complete and normal charge-discharge cycle, taking note of the battery shelf life (which is the time an inactive battery can be stored before it becomes unusable), temperature effects and many more. Unable to ensure a normal charge-discharge, especially discharge, cycle was found to be the number one reason batteries quickly deteriorated. Hence caring and managing of batteries is and has been taken seriously.

Battery Management Systems (BMS) is also a system involving care for batteries. It has been in existence for long but it meant different things to different people. To many people, it simply meant battery monitoring. For the power or plant engineer responsible for standby power whose battery is the last line of defense against, for instance, a power blackout or a telecommunications network outage BMS means a system(s) that encompass methods for keeping ready a back-up battery to deliver full power in addition with monitoring and protecting the battery [12]. People that see it simply as monitoring easily make use of its principles of using monitoring units to detect state of battery deterioration or a set point of discharging level.

A battery discharge level alarm/detection circuit was first patented in the United States on February 1979 [13]. Ever since then, a lot of inventions involving battery monitoring have been patented. A quick search on the web reveals a whole lot of companies that have ventured into the low-voltage detection business products with so many variations. Shaanxi Aitelong Technology, in Mainland China has a battery online monitor system that the company produced, where with

an internet connection, your device or system will, among other functions, be put on watch and alert will be made when it's found that the battery of the system on watch has fallen to a particular set point [14]. Shanghai Betung Auto Parts, a company in Shanghai, Mainland china also has a low battery indicator as one of their products. It has an operating voltage of 27V-45V, a nominal current of 50mA and a maximum operating current of 60mA. When the battery it monitors is used up to 20% left, it flashes some LEDs [15]. Dallas Semiconductor Company, now a subsidiary of Maxim Integrated Products, on February 3, 2003 designed a low battery indicator that uses a low battery CMOS integrated circuit, an inexpensive comparator with shutdown capability in a 6-pin SC70 package. It remains in shutdown while the battery voltage is at normal operative levels, but asserts low battery output when the battery voltage falls below a preset threshold; to provide a LED visual indication of a low battery condition without excessive battery current drain. This is achieved by sending pulse to the LED at a low frequency and low duty cycle and conserving battery current in the off cycle by placing comparator in shutdown [16] and lot of other companies too, most notably Cadex Electronics. They have been in existence for the past 25 years building a complete line of advanced battery test and service products including various types of monitoring products [17].

Individual designers are also not left out. With the likes of Domie James, a freelance circuit engineering designer, who has designed and constructed a lot of functional and electronics circuits, designed, around 2003, a low battery indicator whereby he employed the use of LM741 Op-Amp, three resistors (two of which were 1k  $\Omega$  and the third 100  $\Omega$ ), zener diode 5.1 V and LED. Once the battery voltage drops below a certain predefined value, the LED is illuminated. Also, George Steiner is a sort of hero among remote-controlled freaks. He published a book called "A to Z of Radio Control Electronic Journal" back in the 1990s. Among the many circuits

provided in the book it involved a low voltage alarm circuit for glider receiver battery. This design has a trigger/set point voltage of 4.3 volts and it draws 1mA or less when quiet and about 4mA when buzzing. Today, variations of this circuit design are majorly being used by makers of remote-controlled aircraft, to monitor the battery that powers their servo motors. David A Johnson is a graduate of University of Idaho and a member of IEEE. He is the CEO of David Johnson & Associates, a consulting electronics engineering firm. Mr. Johnson has eight patents and two more pending, as of the time of these writing. He has a broad spectrum of experience that includes applications engineering, product research, design and development, electronic circuit design and some more. As of October 2007, his website, [www.discovercircuits.com](http://www.discovercircuits.com), has over 26,000 circuits. Of personal interests are AC Line Under/Over Voltage Alarm, 9V Battery Voltage Monitor, 12V Battery Voltage Monitor, Battery-Low Flasher, Acceptable Voltage Indicator and many more.

There is also an invention that relates to hotel entertainment systems. More particularly, this invention relates to low battery level detection circuits in remote control units of hotel television and/or pay-per-view movie systems. The patent was filed by the inventors Vernon E. Hills and Gary L. Kolbeck on the 23<sup>rd</sup> of June 1993. It involves the hotel business, where maximizing guest satisfaction is a priority. Customer dissatisfaction or guest frustration causes complaints which ultimately result in a loss of revenue. So in the area of entertainment (hotel television and pay-per-view movie system) they usually come equipped with a hand-held remote control unit to provide increased comfort to the guest. The batteries must be kept fresh so as to satisfy even the pickiest residential user. Guest complaints usually detect end of the batteries life. As this is not supposed to be, the invention provides a battery level detection circuit imbedded within a hand-held remote control unit of the television system to check the battery voltage under actual guest

operation conditions. The results of the battery check are relayed to a guest terminal, and then to a central computer. Based on the results relayed to the central computer, hotel personnel are supplied with a report listing rooms with impending battery failure. The invention includes a low power, low voltage comparator circuit within the remote control unit of the television system. To prevent additional battery drain by the low battery detection circuit from adversely affecting battery life of the remote control unit, the circuit is activated only when the on/off key of the unit is pressed. When the on/off key is pressed, the comparator circuit is powered. There is no excess hard wire connections associated with the detection circuit. Instead, the same infrared signal which is encoded to turn the television "on" or "off" carries additional information, i.e. the battery voltage status of the remote control unit to the central computer [18].

The problem with this sort of circuit design/invention is basically substandard components and unreliable performance. A lot of these products come from Mainland China where the production quality is questionable. As for the unreliability, some products, due to one reason or the other lack precision. The lack of precision is mostly traced to the type of components used in the design process. The fact that it's powered by the same battery its monitoring, at times, can be a source of problem, making the battery run down quickly. Care must be taken in the selection of the passive and active components.

With that said, this project does not differ much from all the inventions listed above in that it is also a voltage monitoring circuit but it specifically provides an audible and visual low voltage warning for the battery it is monitoring. It is powered by the same battery. When the battery voltage is above the set point, the circuit is idle. If the battery voltage should fall below the set point, the LED will light and the speaker will emit a periodic beeping sound to warn of the

impending loss of power. The circuit was designed for monitoring solar systems, but it could also be useful for automotive systems and any other device battery-powered. It's very compact, portable and straight to the point.

# CHAPTER THREE

## 3.0 DESIGN AND IMPLEMENTATION

### 3.1 PRINCIPLES OF OPERATION

A battery low voltage detector/alarm works with the principle of comparing two voltages. It is powered by a battery; the battery that it is monitoring. For this circuit design, there are ranges of batteries to be monitored; between 7.5 volts to up to 12 volts.

### 3.2 REGULATING AND VARYING UNIT

The regulating and varying unit is shown in fig. 3.2. This shows a 7805 voltage regulator passing output to the comparison and switching unit.

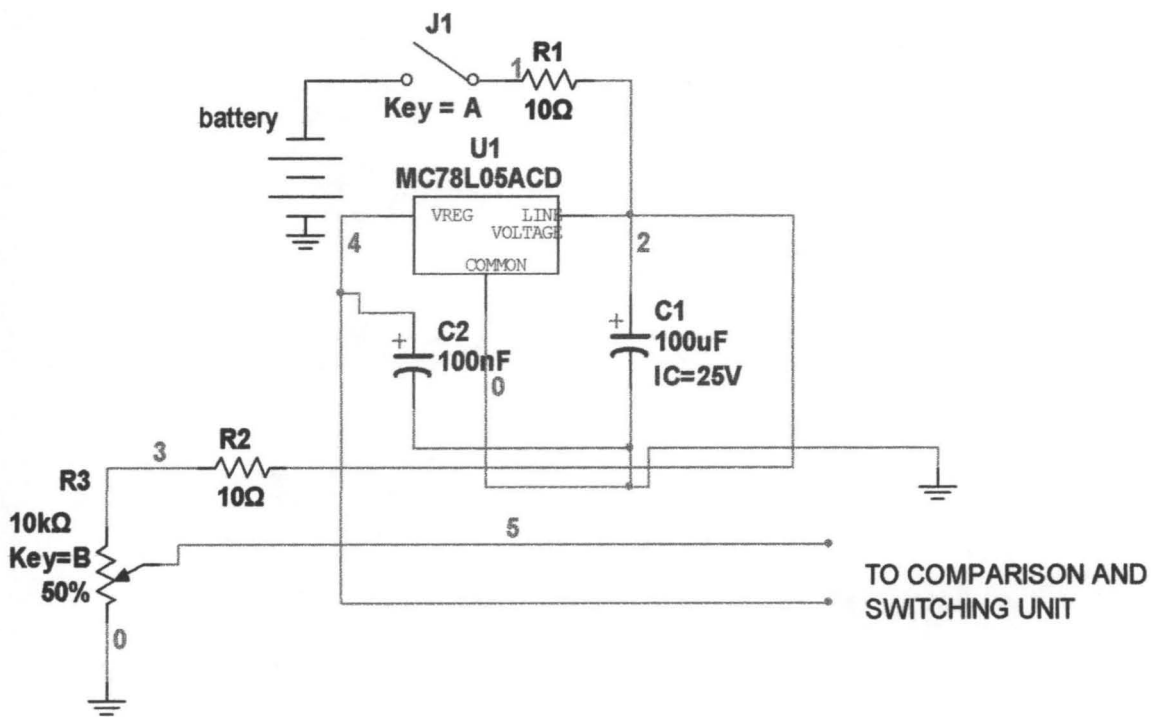

Fig 3.1 Regulating and Varying Unit

### 3.2.1 VOLTAGE REGULATOR

Regulators are semiconductor device that accepts input voltages and produces a reduced output voltage and maintains a constant voltage level. The **78xx** (also sometimes known as **LM78xx**) is one of its series of devices in a family of self-contained fixed linear voltage regulator integrated circuits.. When specifying individual ICs within this family, the *xx* is replaced with a two-digit number, which indicates the output voltage the particular device is designed to provide. For example, the 7805 has a 5 volt output. Fig. 3.2 shows an image of a voltage regulator.

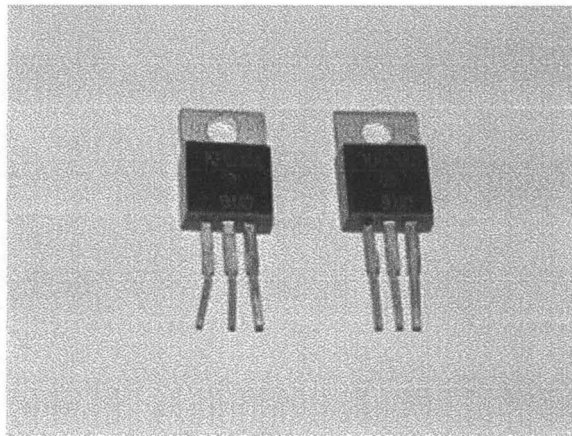

Fig 3.2 Voltage Regulator

The 7805(LM78L05) is a three terminal positive regulator. It is available in several shapes. It has a fixed output voltage of 5 Volts, making it useful in a wide range of applications. It is available in a variety of packages with current ratings from 100 mA to 3 A. Small TO-92 packages, commonly used for low-power transistors, and small surface-mount packages house the 100 mA versions, whereas TO-220 packages and the surface mount equivalent DPAK house the higher current variants. The voltages available allow the LM78L05 to be used in logic systems, instrumentation, Hi-Fi and other solid state electronic equipment. Application of the 7805 is illustrated in Fig 3.3.1 below. It is recommended that high-frequency bypass capacitors be placed

at the input and output nodes to reduce noise and improve the overall circuit's high-frequency response. Although  $0.33\text{-}\mu\text{F}$  and  $0.1\text{-}\mu\text{F}$  values are the common manufacturer's recommendations, larger high frequency capacitors can be used [19]. For this project,  $100\text{-}\mu\text{F}$  and  $0.1\text{-}\mu\text{F}$  were respectively used at the input and output nodes. The regulator is not designed to handle an output voltage that is higher than the input voltage by more than one diode drop. Fig. 3.3 shows the internal operating circuit of a voltage regulator, including the flow of voltage.

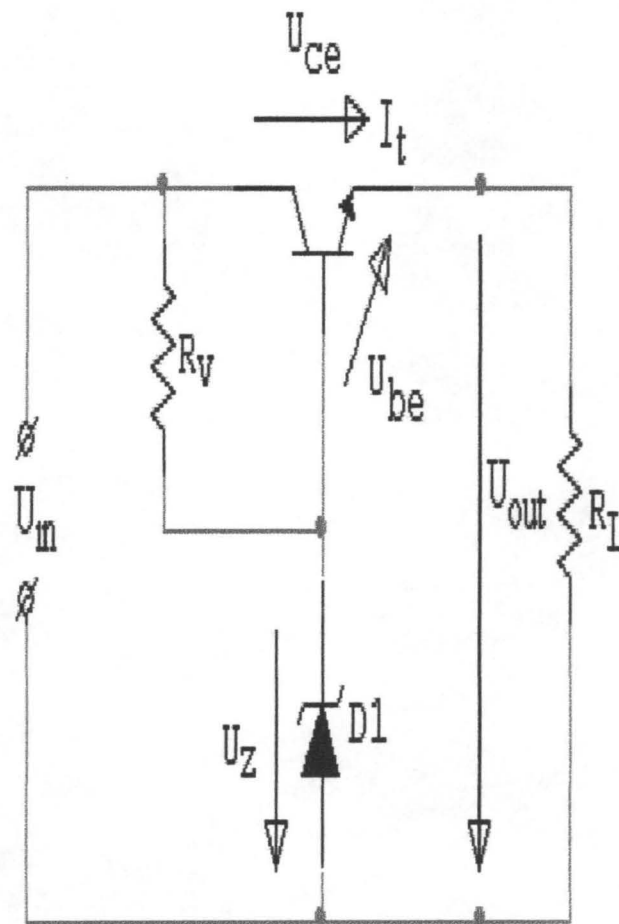

Fig. 3.3 Circuit of a Voltage Regulator

The regulator uses the power source, having voltage  $U_{in}$  that may vary over time. It delivers the relatively constant voltage  $U_{out}$ . The output load  $R_L$  can also vary over time. It must be



remembered that for such a device to work properly the input voltage must be larger than the output voltage and Voltage drop must not exceed the limits of the transistor used. The output voltage is equal to  $U_Z - U_{BE}$ ; where  $U_{BE}$  is about 0.7v and depends on the load current

### 3.2.2 RESISTORS

Resistors determine the flow of current in an electrical circuit. Where there is high resistance then the flow of current is small. Where the resistance is low, the flow of current is large. Resistance, voltage and current are connected in an electrical circuit by Ohm's Law.

**The color code:** Some resistors have color bands that indicate their values and tolerances. We see three, four, or five bands around carbon-composition resistors. Fig. 3.4 shows two resistors with their values represented by the bands of line colors drawn around them.

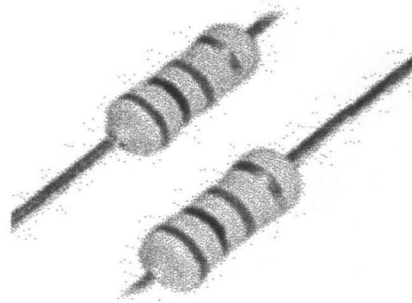

Fig. 3.4 Resistors with color codes

Table 3.1 Resistor color codes with up to nine colours.

Color of band	Numeral (Bands no.1 and 2)	Multiplier Band no.3
Black	0	1
Brown	1	10
Red	2	100
Orange	3	1k
Yellow	4	10k
Green	5	100k
Blue	6	1M
Violet	7	10M
Gray	8	100M
White	9	1000M

A potentiometer (colloquially known as a "pot") is a three-terminal resistor with a sliding contact that forms an adjustable voltage divider. If only two terminals are used (one side and the wiper), it acts as a variable resistor or rheostat. It converts rotary or linear motion from the operator into a change of resistance, and this change is (or can be) used to control anything from the volume of a system to supplied voltage. In this design, it is used for a variable supply voltage. A variable resistor is shown in fig. 3.4. This resistor has a knob.

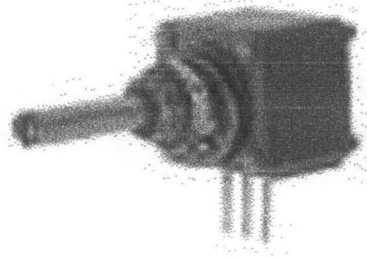

Fig. 3.5 Variable Resistor

### 3.3 COMPARISON AND SWITCHING UNIT

The Comparison and switching unit is shown in fig. 3.3, which basically comprises of a comparator, LM339, connected to a BJT transistor, 2N3906, through a resistor.

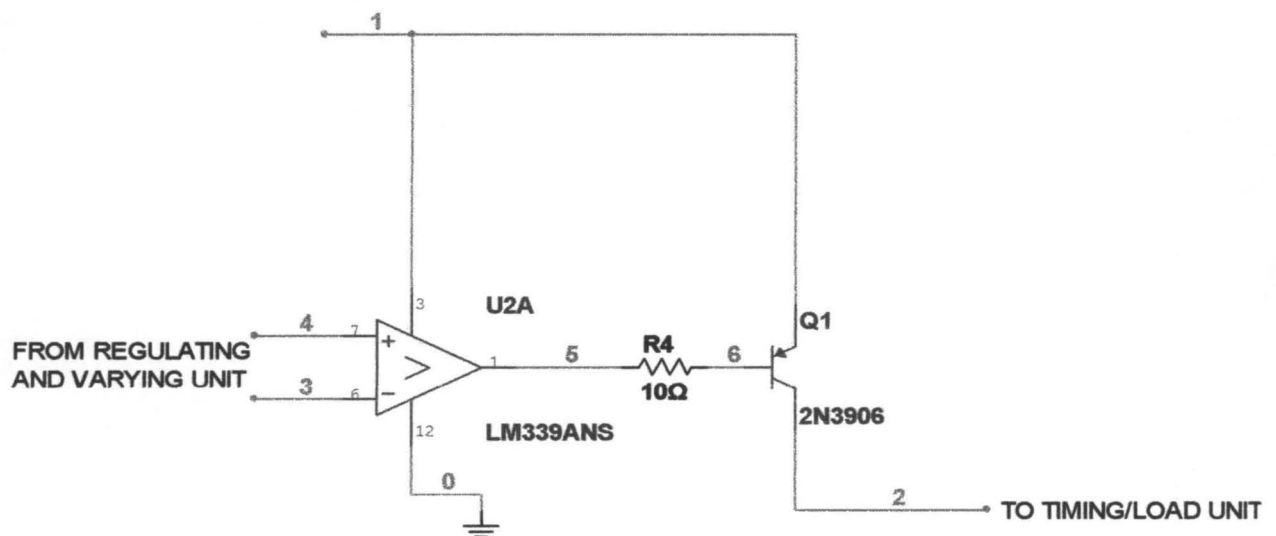

Fig. 3.6 Comparison and Switching Unit

### 3.3.1 COMPARATORS

Comparators, which are based on op-amps, are useful in triggering events based on a signal reaching a certain threshold. Comparators are a key crossover function between the analog and digital worlds. The job of a comparator is to assert its output when the input rises above a certain threshold and reassert its output when the input falls below a threshold. If an op-amp is operated in an open-loop topology, it can be adapted to serve as a comparator. An LM339 Quad Comparator is shown in fig.3.7

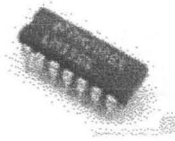

Fig. 3.7 LM339 Quad Comparator.

Op-amps are designed specifically for linear operation in closed-loop configurations. When operated open loop, some op-amps may exhibit unstable output behavior. A comparator IC is specifically designed for open-loop operation with approximately rail-to-rail output behavior and fast switching times. Op-amp manufacturers discourage using op-amps as comparators for these reasons [19]. So, a dedicated voltage comparator will generally be faster than an all-purpose operational amplifier pressed into services as a comparator. A dedicated voltage comparator chip such as LM339 is designed to interface with a digital logic interface (to a TTL or CMOS). With a maximum input offset voltage of 5 volts, Response Time of 0.5 us, Supply Minimum of 2 Volt, Supply Maximum of 36 Volt, Offset Voltage maximum of 2 or 5 mV at 25C [20], the LM339 was the ideal choice of comparator for the project design.

The output is a binary state often used to interface real world signals to digital circuitry. Because comparators have only two outputs states, their output are near zero or near the supply voltage.

### 3.3.2 TRANSISTORS

A transistor is a semiconductor device used to amplify and switch electronics signals. It has at least three terminals for connection to an external circuit. A BJT Transistor is shown in fig. 3.8, where the emitter, base and collector are also indicated.

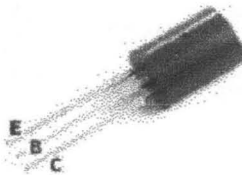

Fig. 3.8 A BJT Transistor

When a transistor is used as a switch, as it is being used in this project, it must be either off or fully on. In the fully ON state, the voltage  $V_{ce}$  across the transistor is almost zero and the transistor is said to be saturated because it cannot pass any more collector current  $I_c$ . The output device switched by transistor is usually called the load.

The power developed in switching transistor is very small;

- In the OFF state: power =  $I_c \times V_{ce}$ , but  $I_c = 0$ , so the power is zero.
- In the full ON state: power =  $I_c \times V_{ce}$ ,  $V_{ce} = 0$  (almost), so the power is very small [21].

Furthermore the 2N3906 was used in this design. It is a common PNP BJT Transistor.

### 3.3.3 BJT SWITCH CALCULATIONS

Suppose a BJT with a 5V supply is designed to switch a 5V 20mA lamp on and off. The transistor chosen is from a batch with variations in  $h_{fe}$  from 100-500. The switching configuration is for common emitter. To find a value for  $R_b$  to work with any transistor in the same gain group, the following must be done.

As the transistor chosen may have any  $h_{fe}$  between 100 and 500 then the minimum current gain is chosen (100). The collector current is 20mA; the required base current is therefore:

$$h_{FE} = I_C / I_B \quad (1)$$

$$I_B = I_C / h_{FE(\min)} = 20 / 100 = 0.2\text{mA} \quad (2)$$

The value of  $R_b$  can now be found. As the switching input,  $V_{in}$  is 5V and the base emitter voltage of the transistor,  $V_{be}$  is 0.6V then 4.4V is developed across  $R_b$ . As a base current of 0.2mA is required, then:

$$R_b = 4.4 / 0.2 = 22\text{K} \quad (3)$$

Transistors with gain equal to or higher than 100 will easily work and light the lamp. The collector emitter voltage of the transistor will be very low (around 0.1 V) the power dissipated in the transistor is also low

$$I_C \times V_{ce} = 2\text{mV} \quad (4)$$

and, almost full power is developed in the load.

The procedure below explains how to choose a suitable transistor

1. The transistor's maximum current  $I_{C(max)}$  must be greater than the load current

$$\text{load current } I_C = \frac{\text{supply voltage}(V_s)}{\text{load resistance}(R_L)} \quad (5)$$

2. The transistor's minimum current gain  $h_{fe(min)}$  must be at least five times the load current  $I_C$  divided by the maximum output current from the chip.

$$h_{FE(min)} > 5 \times \frac{\text{load current } I_C}{\text{max. chip current}} \quad (6)$$

3. Choose a transistor which meets these requirements and make a note of its properties:

$I_{C(max)}$  and  $h_{FE(min)}$ .

4. Calculate an approximate value for the base resistor:

$$R_B = 0.2 \times R_L \times h_{FE} \text{ or } R_B = \frac{V_s \times h_{FE}}{5 \times I_C} \quad (7)$$

And choose the nearest standard value [22].

### 3.4 TIMING AND LOAD UNIT

The timing unit is shown in fig. 3.9. It consists of two timers, the LED, and the speaker. The two timers are connected in monostable mode. The first timer is acting as a tone generator, the second timer is acting as a low duty pulse generator

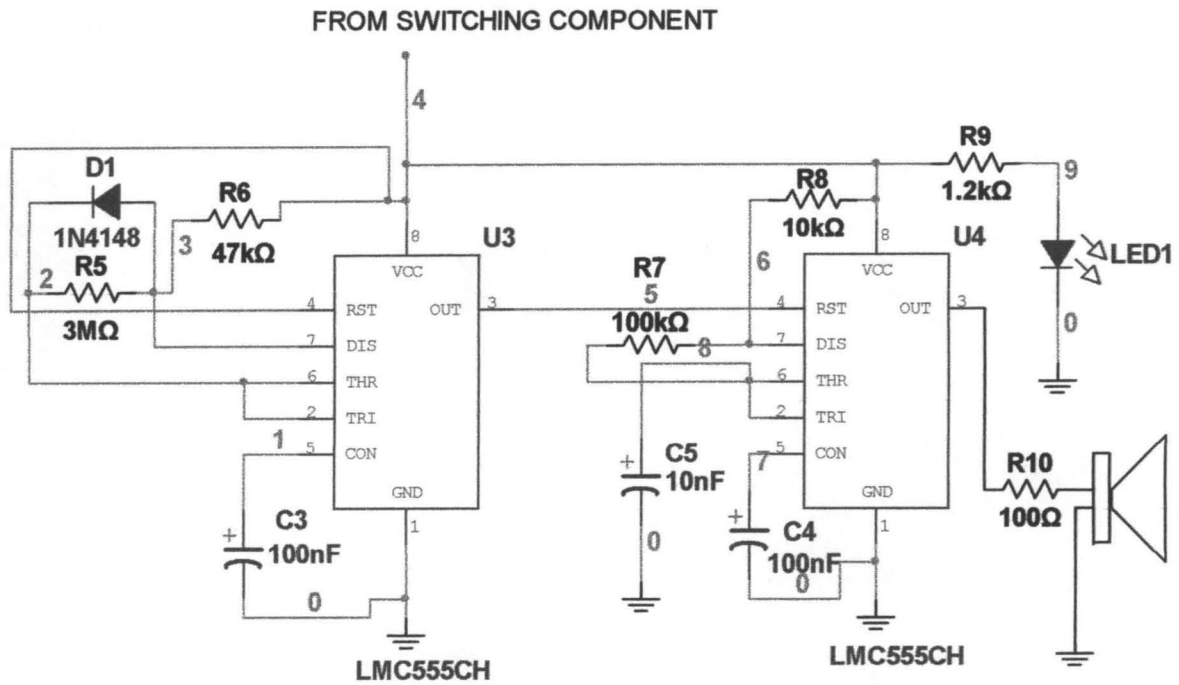

Fig. 3.9 Timing Unit

### 3.4.1 LIGHT EMITTING DIODE (LED)

The LED is a semiconductor light source. LEDs are used as indicator lamps in many devices and are increasingly used for lighting. An LED is shown in fig 3.10. LEDs also have polarities.



Fig. 3.10 LED

They are frequently used as a pilot light in electronics circuits and appliances to indicate whether the circuit is closed or not. The flat side of the bulb or the shortage of the two wires extending from the LED is the negative end and should be connected to the negative side of the battery. LED's operate relatively at low voltage between 1 to 5 volts and draws current of about



LEDs are constructed from various semiconductors and metals that emit visible or invisible light when forward biased. LEDs exhibit forward voltages that are substantially higher than normal diodes, typically in the range of 2 to 3 V. Whether an LED is wired to the power supply to provide a “power on” indicator, or it is connected to the output pin of an IC, it should be current limited using a series resistor. Each LED has its own specifications for  $V_F$  and  $I_F$ . The current-limiting resistor should be chosen to provide the required current given the supply voltage and  $V_F$ . In Fig. 3.5.1, the diode is assumed to have  $V_F = 2$  V and the supply voltage is 5 V. The resistor therefore drops 3 V and allows 13.6 mA of current to flow through the circuit. Allowing more current to flow through the LED will make it glow brighter but will also cause it to dissipate more heat. Most small LEDs emit sufficient light at currents ranging from 10 to 30 mA. In situations where power savings are critical, less current may be possible, depending on the desired light intensity. LEDs are available in a wide range of colors. At first, only shades of green, red, and yellow were commonly found. Blue LEDs became widely available in the late 1990s, allowing full-color red-green-blue (RGB) displays. Common household remote control units rely on infrared LEDs. Ultraviolet LEDs are available as well for special applications [19].

### 3.4.2 TIMERS

The 555 Timer IC is an integrated circuit (chip) implementing a variety of timer and multivibrator applications, designed by Hans R. Camenzind in 1970 and brought to market in 1971 by Signetics (later acquired by Philips) [23]. The figure of a 555 timer shown in fig. 3.11 is the more common 8 pin DIP form type.

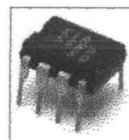

Fig. 3.11 A 555 Timer

All IC timers rely upon an external capacitor to determine the off-on time intervals of the output pulses as it takes a finite period of time for a capacitor to charge or discharge through a resistor.

That time can be calculated with the simple expression [24]

$$t = R \times C \quad (8)$$

The 555 has three operating modes: monostable mode, astable mode and bistable mode. Here, the timer has a single stable state which is the off state. Whenever it is triggered by an input pulse, the monostable switches to its temporary state. It remains in that state for a period of time determined by  $t = R \times C$

The other basic operational mode is the astable mode. This is simply an oscillator. It generates a continuous stream of rectangular off-on pulses that switch between two voltage levels. The frequency of the pulses and their duty cycle are dependent upon the RC network values.

### 3.4.3 CALCULATIONS ON TIMERS

Two timers were used to generate the pulses. The first is U3, according to the circuit diagram.

This is a low duty pulse generator. The next timer, U4, is the tone generator.

Frequency of operation of the astable circuit is dependent upon the values of R1, R2 and C with the formula;

$$f = 1 / (0.693 \times C \times (R1 + 2 \times R2)) \quad (9)$$

The time interval is related to the frequency by

$$t = 1 / f \quad (10)$$

Where  $t = t_1 + t_2$ . For Duty Cycle,

$$D = t_1 / t = (R1 + R2) / (R1 + 2R2) \quad (11)$$

So, for  $t_1$  and  $t_2$ ,

$$t_1 = 0.693(R1 + R2)C \quad (12)$$

$$t_2 = 0.693 \times R_2 \times C$$

(13)

Substituting into the equations starting from eqn 9,

$$f = 1/(0.693 \times 1\mu\text{F} \times (47\text{k} + 2 \times 3\text{M})) = 0.238\text{Hz}$$

Therefore, for U3,

$$t = 1/0.238 = 4.19 \text{ seconds,}$$

$$t_1 = 0.693(47\text{k} + 3\text{M})1\mu\text{F} = 2.11\text{seconds,}$$

$$t_2 = 0.693 \times 3\text{M} \times 1\mu\text{F} = 2.08\text{seconds,}$$

$$\text{duty cycle} = 2.11/4.19 = 0.51 = 50\%,$$

This value of duty cycle for the first timer means that the output pulse is high for 50% of the total period of about 4 seconds.

For second timer, U4

$$f = \frac{1}{0.693 \times 0.01\mu\text{F} \times (10\text{K} + 2 \times 100\text{K})} = 687.14\text{Hz}$$

$$t = 1/687.14 = 0.00145 \text{ seconds,}$$

$$t_1 = 0.693(10\text{k} + 100\text{k})0.01\mu\text{F} = 0.0007623,$$

$$t_2 = 0.693 \times 100\text{k} \times 0.01\mu\text{F} = 0.000693,$$

$$\text{duty cycle} = 0.0007623/0.00145 = 0.53 = 53\%$$

Meaning the pulse of the second timer is high for 53% of the time.

Additional capacitor is added to pin 5 for noise immunity.

Other passive components include resistors, capacitors and diodes.

### 3.5 DIODES

Are two-terminal electronics components that conduct electric current in only one direction. This is a crystalline piece of semiconductor material connected to two electric terminals. The most

common function of a diode is to allow an electric current to pass in one direction (called the diodes forward direction) while blocking current in the opposite direction. Better and more stable timing output is created with the addition of a diode to the RC network of a timer. Any small signal diode will serve the purpose [25]. For this design, a 1N4148 is used. Fig. 3.12 shows an example of the type of 1N4148 diode

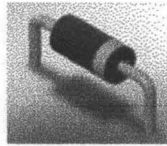

Fig. 3.12 A diode

### 3.6 CAPACITORS

A capacitor is a passive electronic component consisting of a pair of conductors separated by a dielectric (insulator). When there is a potential difference (voltage) across the conductors a static electric field develops in the dielectric that stores energy and produces a mechanical force between the conductors. An ideal capacitor is characterized by a single constant value, capacitance, measured in farads. This is the ratio of the electric charge on each conductor to the potential difference between them. Capacitors are widely used in electronic circuits for blocking direct current while allowing alternating current to pass, in filter networks, for smoothing the output of power supplies, in the resonant circuits that tune radios to particular frequencies. All IC timers rely upon external capacitors to determine the off-on time intervals of the output pulses. As shown in fig. 3.13 capacitors have their negative polarity indicated by a line of stripe along one of the sides of the capacitor.

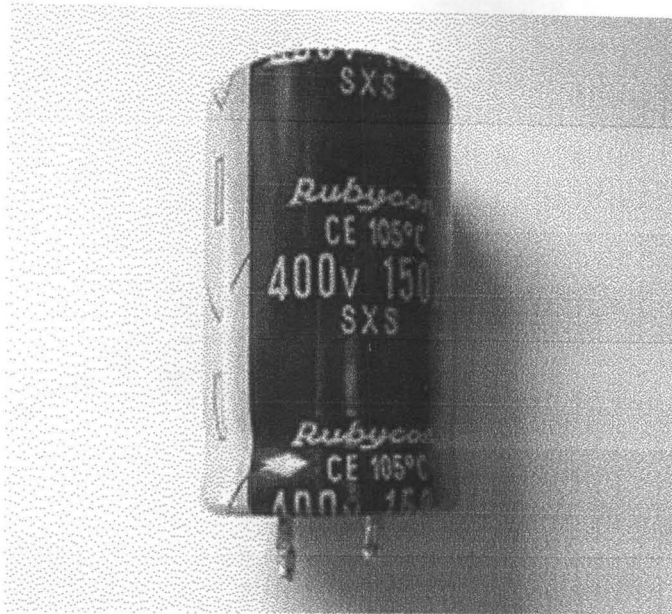

Fig. 3.13 A Capacitor

Usually, in an IC, for the RC network, the value of the capacitor is the first thing to be determined. However, leakage is more important than the value of the capacitor. Larger value capacitor has larger leakage so low leakage types are generally used for timer ICs for long timing periods, as used in this design.

### 3.7 CONSTRUCTION

The circuit was first constructed on a bread board to ensure that it worked perfectly well before it was transferred to a Vero board permanently. The components were placed on the line Vero board and neatly soldered.

#### 3.7.1 CASING

For a battery low voltage detector/alarm, the casing could either be wood or plastic. A transparent plastic was used as the top cover while a light wood was used for the sides.

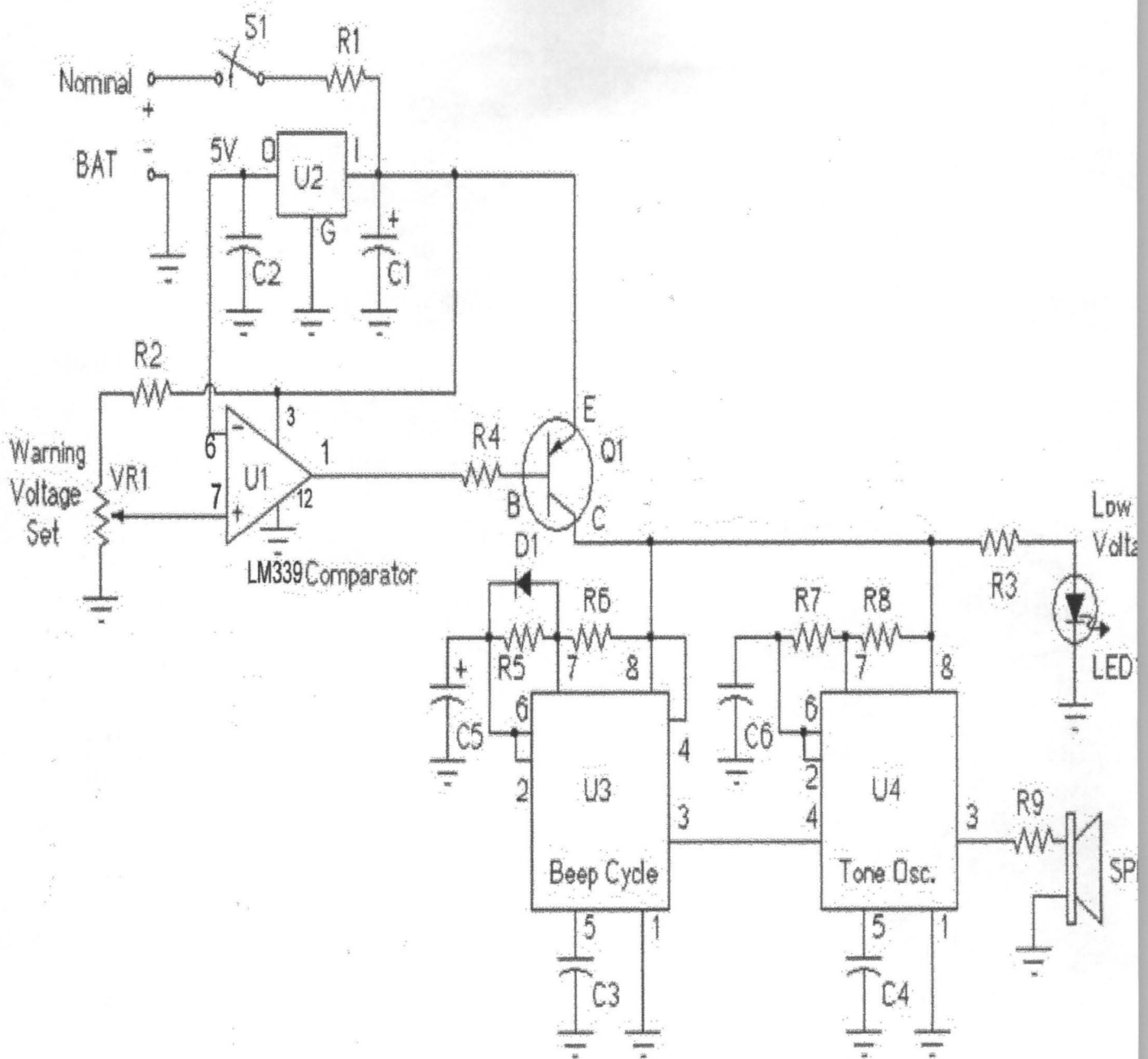

Fig. 3.14 Circuit diagram of the complete design.

Table 3.2 gives a list of the components used throughout the design and their corresponding values, both during the breadboard connection and the Vero board connection of the circuit.

Table 3.2 List of Components and their Values

R1	10 ohms
R2	3.3 K ohms
R3	1.2 K ohms
R4	10 K ohms
R5	3M ohms
R6	47 K ohms
R7	100 ohms
R8	10 ohms
R9	100 ohms
C1	100 microfarads
C2-C4	0.1 microfarads
C5	1 microfarads
C6	0.01 microfarads
Q1	2N3906
D1	1N4148
VR1	10 K ohms
SPK	8 ohms
S1	SPST Switch
U1	CA3160 CMOS Op-amp
U2	78L05 Low current 5V regulator
U3-U4	LMC555 CMOS timer

## CHAPTER FOUR

### 4.0 TEST, RESULT AND DISCUSSION

#### 4.1 TEST AND RESULT

To test different values of voltages, a variable dc adapter was used in place of a battery. That way, the value of the potentiometer could be set for every rounded up voltage value available in the range. This particular adapter has the following voltages: 7.5V, 9V and 12V.

Table 4.1 shows the various voltage levels tested and their corresponding set point at which they will be set for alert when the batteries fall to that level. For each battery level, the adapter is set to a voltage level (set point) lower than the battery level. Upon switching on the circuit, the knob of the potentiometer is tuned until an alert is made. A table giving the result of the potentiometer value at specific set points and tested voltage is shown in table 4.1.

Table 4.1 Result of Set Points against Tested Voltages

Battery voltage/Tested Voltage (volts)	Set point(volts)	Potentiometer Value (kilo-ohms)
7.5	6.0	3.5
9.0	7.5	5.8
12.0	11	9.2



## **4.2 DISCUSSION OF RESULTS**

For the results obtained above, the average time taken for the batteries to discharge to the set point is a factor that depends on the amount of load connected to the battery. Ordinarily, the circuit takes about 0.6A from a 9V battery so, depending on what the battery is powering, that determines the times it takes to reach the set point where it gives out an alert.

Any set point can be chosen for each of the battery voltages. The basic thing is that, due to a regulator of 5 volts is being used, only batteries above 5 volts must be used. The aim of the set voltage is to set a particular voltage of reference incase a permanent / fixed rheostat is to be used. This is necessary when the circuit is being placed in non-technical hands

## **4.3 LIMITATIONS**

A limitation of this circuit is that it cannot measure batteries below 5 volt, owing to the fact that a regulated fixed voltage of 5 volts is used in the design.

## **4.4 TROUBLESHOOTING**

To troubleshoot this circuit in the event of damage or non-functionality, the major components to be checked out are the comparator, the regulator and the variable resistor. The variable resistor is not a preset one so it is likely to have been moved from its set point.

## **CHAPTER FIVE**

### **5.0**

## **CONCLUSION**

### **5.1 SUMMARY**

A battery-low voltage detector is a sort of alarm for batteries. Batteries should not be allowed to go below a certain voltage else it could start becoming inadequate. This certain voltage (also known as set point) can be set by this circuit. When the battery reaches that voltage level, an alert is made. This circuit does not put additional load on a battery. The alerts the battery makes upon reaching the set point are audio and visual.

### **5.2 RESULTS OBTAINED**

The results obtained are a reflection of the voltage level of the battery in question, the required set points and the load connected to the battery. This last one actually determines how long it takes the battery to reach the set point.

### **5.3 PROBLEMS ENCOUNTERED**

The problems encountered were numerous. During the process of placing the circuits on the Vero-board, some connections were bridged hence, there was the need to de-solder and re-solder. The components malfunctioned due to overheating. The battery quickly discharged until some adjustments were made to the choice of components. After then, the rate of discharge of the battery became reduced to a favorable extent.

## REFERENCE

- [1] B.L. Theraja and A.K. Theraja, "A Textbook of Electrical Technology", Multicolor Illustrative Edition, S. Chand and Company LTD, 2005, vol. 1, pp 360, 354, 334, 346.
- [2] Battery Voltage Monitoring, <http://www.acroname.com/howto/battery/battery.html>, accessed on 9/11/2010
- [3] Hydrometer- Wikipedia, the free encyclopedia, <http://en.wikipedia.org/wiki/Hydrometer>, accessed on 9/11/2010.
- [4] Voltmeter - Wikipedia, the free encyclopedia, <http://en.wikipedia.org/wiki/Voltmeter>, accessed on 9/11/2010.
- [5] History of the battery - Wikipedia, the free encyclopedia, [http://en.wikipedia.org/wiki/History\\_of\\_the\\_battery](http://en.wikipedia.org/wiki/History_of_the_battery).htm, accessed on 9/11/2010.
- [6] World's biggest battery switched on in Alaska – Telegraph <http://www.telegraph.co.uk/technology/3312118/Worlds-biggest-battery-switched-on-in-Alaska.html>, accessed on 9/16/2010
- [7] ABB constructs world's largest battery energy storage system in Fairbanks, Alaska, [http://ezinearticles.com/?cat=Computers-and-Technology:Hardware/What\\_is\\_the\\_Biggest\\_Battery\\_and\\_others\\_Interesting\\_Battery\\_Facts.htm](http://ezinearticles.com/?cat=Computers-and-Technology:Hardware/What_is_the_Biggest_Battery_and_others_Interesting_Battery_Facts.htm) accessed on 9/16/2010.
- [8] Analog Devices Introduces Lithium-Ion Battery Monitoring and Protection System for Energy, Industrial and Automotive Applications | Press Releases | Analog Devices [http://www.analog.com/en/press-release/3\\_5\\_10\\_ADI\\_Introduces\\_Lithium-Ion\\_Battery/press.html](http://www.analog.com/en/press-release/3_5_10_ADI_Introduces_Lithium-Ion_Battery/press.html), accessed on 9/12/2010.
- [9] Alarm clock - Wikipedia, the free encyclopedia, [http://en.wikipedia.org/wiki/Alarm\\_clock](http://en.wikipedia.org/wiki/Alarm_clock), accessed on 09/17/2010
- [10] Human factors/ergonomics-Alarm management, <http://www.hse.gov.uk/humanfactors/topics/index/alarm-management.htm>, accessed on 09/10/2010.
- [11] Chernobyl incident - Wikipedia, the free encyclopedia, [http://en.wikipedia.org/wiki/Chernobyl\\_disaster?wasRedirected=true](http://en.wikipedia.org/wiki/Chernobyl_disaster?wasRedirected=true), accessed on 09/10/2010.
- [12] Battery Management and Monitoring Systems BMS, <http://www.mpoweruk.com/bms.htm>, accessed on 9/11/2010.

- [13] Battery Charge Indication Methods, Battery Charge Monitoring Devices, Rechargeable Batteries, and Articles of Manufacture - Patent application, <http://www.faqs.org/patents/app/20100070220>, accessed on 9/11/2010.
- [14] Aitelong Technology Co., Ltd, specialist in R&D and production and marketing of all kinds of communication networks, backup power supply maintenance test apparatus <http://www.aitelong.com/index.asp>, accessed on 9/18/2010.
- [15] Shanghai Betung Auto Parts Co., Ltd, production of gauge, meter, auto parts, tachometer, speedometer, pressure gauge, temperature gauge, odometer, amperage, voltmeter, pressure, temperature, press-gauge, temp-gauge, Tire Pressure Monitoring System; <http://www.betung.com/>, accessed on 9/18/2010.
- [16] Dallas Semiconductor – Wikipedia, the free encyclopedia, [http://en.wikipedia.org/Wiki/Dallas\\_Semiconductor](http://en.wikipedia.org/Wiki/Dallas_Semiconductor), accessed on 09/16/2010
- [17] Cadex Electronics, <http://www.cadex.com>, accessed on 09/16/2010.
- [18] Low battery detection system -Patent 5506572, <http://www.freepatentsonline.com/5506572.html>, accessed on 9/17/2010.
- [19] Mark Balch, A comprehensive guide to digital electronics and computer system architecture, McGraw Hill, pp 405, 356, 321.
- [20] National Semiconductor Corporation datasheet for LM139/LM239/LM339/LM2901/LM3302 Low Power Low Offset Voltage Quad Comparators
- [21] Tony R. Kuphaldt, Lessons in Electric Circuits, Volume III Fourth Edition, last update December 16, 2002, pp. 53
- [22] Transistor circuits.pdf, Library of Electrical & Electronic Engineering (Lib-E) DIGITAL LIBRARY CD-ROM
- [23] 555 Timer, Wikipedia, the free encyclopedia [http://en.wikipedia.org/555\\_timer](http://en.wikipedia.org/555_timer), accessed on 9/17/2010.
- [24] 555 Tutorial, Library of Electrical & Electronic Engineering (Lib-E) DIGITAL LIBRARY CD-ROM
- [25] Chan, Shu-Park “Section I – Circuits”, *The Electrical Engineering Handbook*, Ed. Richard C. Dorf, Boca Raton: CRC Press LLC, 2000, pp. 31-32