

**DESIGN AND CONSRUCTION OF AN AUTOMATIC
VEHICLE HEADLAMP SWITCHING CONTROL DEVICE**

BY

OBELE BOLUWAJI JOEL.

MATRICULATION NUMBER:

2005/22063EE.

ELECTRICAL AND COMPUTER ENGINEERING DEPARTMENT
SCHOOL OF ENGINEERING AND ENGINERING TECHNOLOGY.

FEDERAL UNIVERSITY OF TECHNOLOGY, MINNA.

NOVEMBER, 2010.

**DESIGN AND CONSRUCTION OF AN AUTOMATIC
VEHICLE HEADLAMP SWITCHING CONTROL DEVICE**

BY

OBELE BOLUWAJI JOEL.

MATRICULATION NUMBER:

2005/ 22063EE.

A FINAL YEAR PROJECT SUBMITTED TO THE DEPARTMENT OF ELECTRICAL
AND COMPUTER ENGINEERING, SCHOOL OF ENGINEERING AND
ENGINEERING TECHNOLOGY,

FEDERAL UNIVERSITY OF TECHNOLOGY MINNA, IN PARTIAL FULFILMENT
OF THE REQUIREMENTS OF THE AWARD OF THE BACHELOR OF
ENGINEERING (B. ENG.) DEGRE IN ELECTRICAL AND COMPUTER
ENGINEERING.

NOVEMBER, 2010.

DEDICATION

This project work is dedicated to the almighty GOD who saw me through all these years, even through my course of study.

Also my regards goes to my beloved parents, Prince and Princess T.A.B. Obele.

DECLARATION

I, Obele Boluwaji Joel, with Matriculation number 2005/22063EE an undergraduate student of the Department of Electrical and Computer Engineering, declare that the work embodied in this project is original and has not been submitted in any part or full to any other university.

OBELE BOLUWAJI JOEL

Obele 20/11/2010

SIGNATURE AND DATE

CERTIFICATION

This is to certify that this project (AUTOMATIC VEHICLE HEADLAMP SWITCHING CONTROL DEVICE) was designed by Obele Boluwaji Joel, 2005/22063EE for the award of bachelor degree in Electrical and Computer Engineering, Federal University of Technology Minna, Niger state.

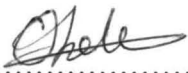

Obele Boluwaji Joel
Student



Mr. Enesi Yahaya
Supervisor

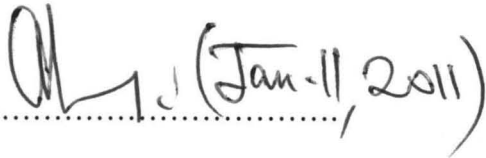

Engr. A.G. Raji
H.O.D.

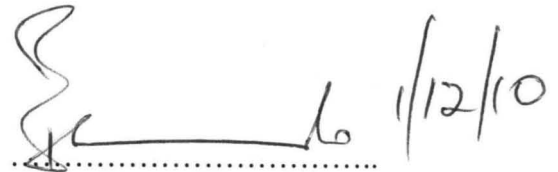

External Supervisor
Engr. Dr. G.I. Igbarah

ACKNOWLEDGEMENT

First and foremost, all praise adoration and glorification goes to the Almighty God who has been taking care of me and particularly for the successful completion of this program. I am also grateful to my parents; Prince and Princess T.A.B. Obele for their support financially, spiritually and morally.

My gratitude to my supervisors (Engr. Abolarinwa, MR. Enesi and MR. Gbagudu) for their relentless effort and advice in putting me through this work and all the staffs in the Department of Electrical and Computer Engineering especially staffs in the departmental laboratory.

My appreciation goes to friends Olutoye Ayodeji, Folorunsho Temitope, Ikuesan Omolade and especially Ojatuwase Oluwafunmilayo Justinah. To my siblings Ibiabor Shedrack, Opukiri Tonyen, Obele Olumuyiwa, Obele Folashade, Obele Tolulope and Okun Daniel whose concerns, prayers and love have been immeasurable to me, I am very grateful.

ABSTRACT

This project presents the design and construction of an automatic switching control unit for automobile head lamp. This device switches the automobile headlamp from bright-lamp to dim-lamp when there is an oncoming vehicle at night with its lights on and switches back to bright lamp after the on-coming car passes by. The basic principle of design is based on the mode of operation of the Light Dependent Resistor (LDR) as a sensing device and a voltage comparator I.C. UA 741.

TABLE OF CONTENTS

Title	Page
Dedication	i
Declaration.....	ii
Certification	iii
Acknowledgement	iv
Abstract	v
Table of Contents	vi
List of Figures	vii
 CHAPTER ONE	
1.1 Introduction	1
1.2 Aims and Objectives	2
1.3 Project Motivation.....	3
1.4 Methodology	3
1.5 Problem Definition	4
 CHAPTER TWO	
2.1 Theoretical Background	5

CHAPTER THREE

3.1	Principle of Operation.....	8
3.2	Design of Power Supply Unit	10
3.3	Control Unit	11
3.31	Voltage Comparator.....	11
3.32	Light Dependent Resistor.....	12
3.3	Switching Unit	17
3.4	Load	20

CHAPTER FOUR

4.1	Construction	21
4.2	Testing	21
4.3	Assembling.....	22
4.4	Precautions.....	22
4.5	Component List	23

CHAPTER FIVE

5.1	Conclusion	24
5.2	Recommendations	24
	References	25

LIST OF FIGURES

Figure 3.1	-	System Block Diagram	9
Figure 3.2	-	System circuit diagram.....	10
Figure 3.3	-	Voltage Comparator IC	11
Figure 3.4	-	Diagram of 8 pin op amp	12
Figure 3.5	-	Light Dependent Resistor	13
Figure 3.6	-	Graph plot of Resistance versus illumination.....	14
Figure 3.7	-	Variable Resistors.....	15
Figure 3.8	-	Internal Circuitry of a Relay.....	18

CERTIFICATION

This is to certify that this project (AUTOMATIC VEHICLE HEADLAMP SWITCHING CONTROL DEVICE) was designed by Obele Boluwaji Joel, 2005/22063EE for the award of bachelor degree in Electrical and Computer Engineering, Federal University of Technology Minna, Niger state.

.....
Obele Boluwaji Joel
Student

.....
Mr. Enesi Yahaya
Supervisor

.....
Engr. A.G. Raji
H.O.D.

.....
External Supervisor

CHAPTER ONE

1.1 INTRODUCTION

In the past years, switching and control of all kind in automobiles has always been done manually. Considering the constant change in technology and increase in people's want for easy life, the use of manual switch is gradually getting phased out hence requesting for automatic switching devices. This has brought about the change of some element in automobiles from manually operated to automated. Examples include automatic gear box systems, button controlled side mirrors, rain sensitive wipers, central locking systems, cruise control systems, air bag systems e.t.c.

With all these examples stated above it will be all right to say "we are approaching an era when cars will drive themselves". Human want for all these stated above is only calling for easiness, comfort and efficient accomplishment of task. For automatic headlamp control, automatic switching control is accomplished with a controller that operates based on the principle of the light dependent resistor (LDR) known as a photocell. Thus the use of LDR which makes use of the light intensity of the oncoming vehicle to conduct current has greatly reduced the need of the driver to manually dim and brighten the car head lamps, thereby eliminating the distraction of manually dimming and brightening of the head lamps by the driver.

Lights are controlled automatically using an electrical circuit incorporated with a relay. This enables the natural toggling of the head lamps between the dim state and the bright state almost independent of human interference. Even as the government/ Federal Road Safety Corps (FRSC) strive to ensure the security of her citizens on and around its high ways(at night), auto dimming of headlamps is highly needed of proper visibility of drivers at night.

Hence, this project is aimed at designing and constructing an auto headlamp dimmer, which switches OFF when the illumination from the opposite oncoming car increases to a set level and also switches ON when the oncoming car passes by (i.e the illumination of the opposite car become zero).

1.2 AIMS AND OBJECTIVE

The primary aim of this project work is to design a device that takes over the job of dimming and brightening of the headlamp system from the driver thereby reducing distraction. Other aims achieved in this project include:

- a) Make driving at night as interesting as driving during the day, thereby automatically managing the visibility of the driver.
- b) Installation or setup of the controller device is simple and easily realisable in terms of size of the installation, wiring and the cost of maintenance is also relatively cheap and easy to maintain.
- c) Ensure that a max safety is achieved by providing a constant illumination at every point based on the illumination of the oncoming vehicle.

Hence the desire to design and construct a system that provides and maintains the required effective control of lighting system for maximum safety on the road at night at a relatively low cost.

1.3 PROJECT MOTIVATION

The motivation behind the design and construction of this project is the need to conserve power during the day when the weather condition is good (good visibility) by using the head lamp in the dim state and the need to provide clear illumination for the drivers during the night or cloudy weather. This is also to solve the problem that will be encountered by wear of the component circuit when operating mechanically or manually.

1.4 METHODOLOGY

The automatic headlamp/down-lamp switching controller device is an electronic device that automatically turns on the bright light at night (during darkness) and turns on the dim during day time (during brightness). This process of switching between bright and dim lamps is achieved by the means of self-regulatory circuit, which depends on the response of a sensory element(LDR) to illumination level of the environment.

The controller switching circuit requires a regulated 12Volts dc power supply for its operation. The device has light dependent resistor (LDR) acting as illumination sensor and an operational amplifier (OP-Amp) as a comparator comparing the night and day voltage across the sensor with a reference voltage.

During the bright condition (either during the day or a car coming from the opposite with its bright lights on or driving through a street with its street lights on at night), enough light falls on the LDR. Its resistance becomes low and the developed voltage across is not sufficiently to bias the transistor to cut-off, this condition deenergize the relay and the relay switches to the normally open thereby

switching on the dim lamp. However, during the dark condition when there is no illumination falling on the Light Dependent Resistor (LDR), its resistance becomes high and enough voltage is developed across the LDR to forward bias the transistor to saturation thereby energizing the relay coil and makes contact between the common and the normally close contacts, hence closing the bright lamp circuit. Thus, the headlamp toggles between the bright/dim lamps automatically at dark and bright conditions respectively by the action of the device due to the illumination of the environment.

1.5 PROBLEM DEFINITION

The problem faced by manually operated toggling between the bright and dim lamps in automobiles are listed below:

- a) Problem of distraction by the manual operation of switch.
- b) Problem of power wasting during the bright condition when the driver fails to switch to the dim lamp.

The above problems of switching between the bright and dim lamps by manual operation is carefully solved by this project work titled "Design and Construction of an automatic vehicle headlamp/down lamp switching control device"..

CHAPTER TWO

2.1 THEORETICAL BACKGROUND

Good visibility through a reasonable distance while driving at night and during bad weather condition is extremely important not just for car and driver's safety but also for the passengers in the car and other road users. It is in fact a logical requirement to make sure the headlights are in good working condition. They serve a great functional purpose despite what people perceive of them.

The main purpose for the headlights is to provide a clear view of the road and prevent accidents at night and during bad weather condition when it is dark on the road. Traffic information agencies states that more than half of crashes occur at night when the driver has poor visibility. When driving in a foggy or stormy weather, it is naturally required of the driver to turn on his headlights to be able to see the road better and to send a signal to an oncoming vehicle. Headlights are mostly used when the road (climatic) condition is not too good for driving. Hence it is imperative to make sure the headlights are in good working condition before you drive the car onto the road. After all you cannot possibly predict what sort of weather is ahead of the day.

Auto lighting plays a major role in keeping you and the car safe and sound. Without the lights at night, you would certainly be like a blind man trying to walk. Headlights are actually one of the important parts of the car lights. Although headlights are one of the long lasting parts of a car, they are still vulnerable to weathering conditions that causes them to lose their functionality. Replacing the headlights when faulty is a sure way of getting the automobile ready for any kind of weather

condition. This is why obtaining good quality bright bulbs as well as the headlights are very important. What you need to look for when replacing the headlights are affordability, durability and reliability of the headlights.

Headlight technology is advancing more and more. There are new safer shapes and styles coming on the market, offering people a brighter and more advantageous future of headlights. The latest innovative ideas are the use of light emitting diode (LED) to enhance the car lighting system as well as halogen bulbs to be more environmentally friendly. Car light comes in different designs, colors, materials and the elements most common among them is the halogen bulb, which is filled up with pressurized gas

As there is advancement in technology, the very much improvement is seen in the car. One can even change the beam direction at the flick of the switch. Car headlight booster has different features. The input voltage is around 10/15 Volts DC. The light, which is used in car, is a HID headlight, which consumes very low energy. HID light protects the car circuit and increases the life of the bulb. As technology improves, lots of changes is been seen in the car. Earlier there where filament light, then vapour light, then came halogen lights and now xenon and LED lights.

Equipping cars with Xenon headlights save lives. This is the finding of a current study by traffic experts Germany. If all vehicles driving at night and bad weather conditions were equipped with Xenon headlights instead of conventional halogen headlights, it would be possible to reduce the number of serious accidents occurring at night on high ways by over 50 percent each year, and by as much as 30 percent on local roads. This in turn equates to a total of six percent fewer accidents

involving casualties and 18 percent fewer fatalities. The investigation by traffic experts is based on a study by the Federal Highway Research Institute (Bundesanstalt für Straßenwesen in Germany, abbreviated to BASt). Its study finds that between 1991 and 2002 the number of road traffic accidents occurring at night in Germany involving casualties decreased more significantly than the number of accidents occurring during the day. The objective of the current study was to find out whether or not there is a correlation between this drop in the number of accidents and innovative developments deployed in the area of vehicle lighting and more specifically the introduction of Xenon headlights. "To find this out, the rate of accidents was compared for high-end cars with and without Xenon headlights. It was proved that on high ways and local roads, Xenon headlights have a statistically significant influence on the reduction of accident rate, than other technical innovations such as anti-lock brakes and airbag systems, e.t.c.". As to be expected, Xenon headlights have no effect on the accident rate in urban traffic due to there being sufficient street lighting in cities. Currently, only around ten percent of all cars registered in Germany are fitted with Xenon lights. The number of night-time accidents is continuing to decrease with the increasing proportion of Xenon headlights.

CHAPTER THREE

DESIGN AND ANALYSIS

3.1 PRICIPLE OF OPERATION

The basic principle of design and operation is based on the mode of operation of the Light Dependent Resistor (LDR) as a sensing element incorporated into a switching circuit consisting (transistors, power source for the headlamp(bright/dim) and relays for switching between bright and dim) depending on whether a vehicle is coming or not.

This device uses a popular I.C (UA 741) connected in a comparator mode with pin-7 connected to the positive rail, the output (pin 6) goes high (1) when the trigger pin 3 is at a voltage level lower than voltage level on pin no 2. Conversely the output goes low (0) when the voltage level at pin 3 is high compared to that of pin 2. So a small change in the voltage of pin-2 is enough to change the level of output (pin-6) from 1 to 0 and 0 to 1. The output has only two states high and low hence cannot remain in any intermediate state. It is powered by a 12Volts DC power supply (battery). Pin 4 is ground, and pin 7 is connected to the positive supply.

To detect the light of an oncoming vehicle night, an LDR is used. The LDR is a special type of resistor whose resistance value depends on the illumination across its surface. It has resistance of about 1 mega ohm when in total darkness, but a resistance of only about 5 kilo ohms when well illuminated. It responds to a large part of light spectrum.

A potential divider circuit is made with LDR and 10 Kilo ohm variable resistor connected in series. It is known that voltage is directly proportional to conductance hence low voltage is obtained from

this divider when LDR is getting light and high voltage in darkness. This divided voltage is given to pin 2 of IC UA741. Variable resistor is so adjusted that it crosses potential of 1/2 in darkness and fall below 1/2 in light.

Sensitiveness of the light dependent resistor is adjusted by the 10k ohm variable resistor. As soon as the output of the comparator goes high (1), the relay is energized thereby switching from the bright lamp to the dim lamp.

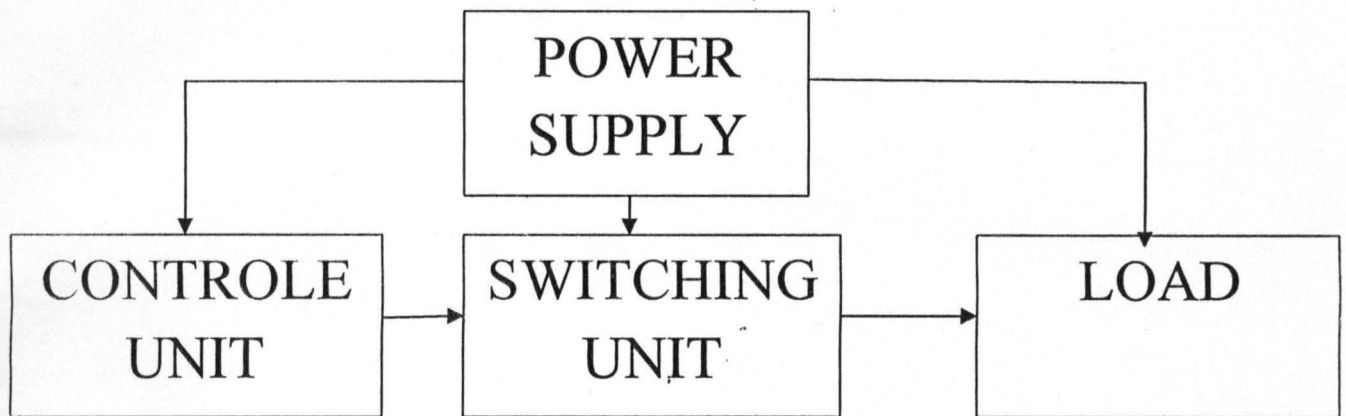

FIGURE 3.1 THE BLOCK DIAGRAM ILLUSTRATING THE OPERATION OF THE SYSTEM.

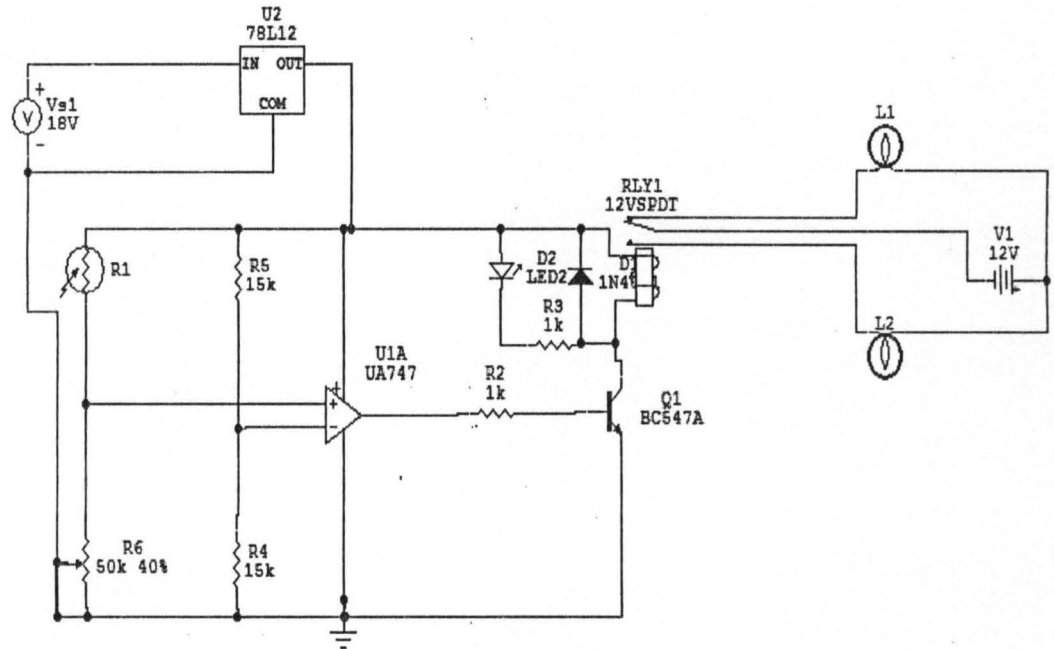

FIGURE 3.2 CIRCUIT DIAGRAM.

This project design process is sectioned into four stages i.e.

1. The power supply(battery)
2. The control unit
3. The switching unit
4. The load

3.2 THE POWER SUPPLY UNIT

In present day, electric power is been generated, transmitted and distributed in the form of alternating current and voltages at very high values. The power supply needed for this project work is not more than 12volts DC supply since its area of application (car) does not usually support DC

voltage supply greater than 12 volts. For the purpose of testing and presentation, a 12 volts DC is required for used as the power supply.

- BATTERY: it consist of a number of cells assembled in a common container and connected together to function as a source of electrical power.

3.3 THE CONTROLE UNIT

The control unit of this device comprises basically of

1. An operational amplifier serving as a voltage comparator.
2. A light dependent resistor (LDR).
3. A variable resistor for presetting.

3.3.1 THE VOLTAGE COMPERATOR

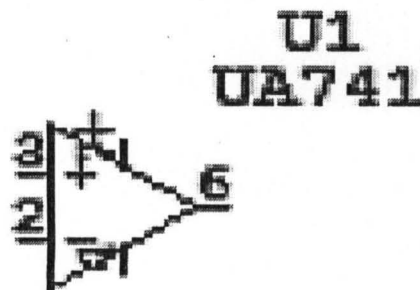

FIGURE 3.3 VOLTAGE COMPARATOR IC

The voltage comparator is a deferential operational amplifier of the type UA741 IC with an offset voltage of about 2 volt. The comparator compeers the registered voltage V_x at the none inverting input with the pre established reference voltage V_{ref} , this comparism provides a result that is the

output of the voltage comparator. If V_x is greater than the V_{ref} , the output signal of the comparator will be high, but if the V_x is lower than V_{ref} , the output of the comparator will be low i.e.

When

$V_x > V_{ref}$ then output voltage is high enough to energize relay switch.

$V_x < V_{ref}$ then output voltage is low hence relay switch is de-energized.

(b)

Figure 3.4 Showing the frequency compensated op amp 8 pin can

Pin 1: offset null.

Pin 2: inverting input.

Pin 3: non inverting input.

Pin 4: connected to negative rail.

Pin 5: offset null.

Pin 6: output.

Pin 7: Vcc.

Pin 8: NC.

3.22 THE LIGHT DEPENDENT RESISTOR (LDR)

The LDR serves as the eye of the device. It senses the illumination level of the environment. This change in the illumination level leads to a change in the resistance build up accordingly.

Based on the resistance across the LDR in conjunction with that of the pre-set value of the variable resistor, a voltage is registered at the non-inverting terminal of the comparator.

From observation, the LDR has a resistance of about 10 mega ohms in darkness and this resistance value falls with increasing illumination.

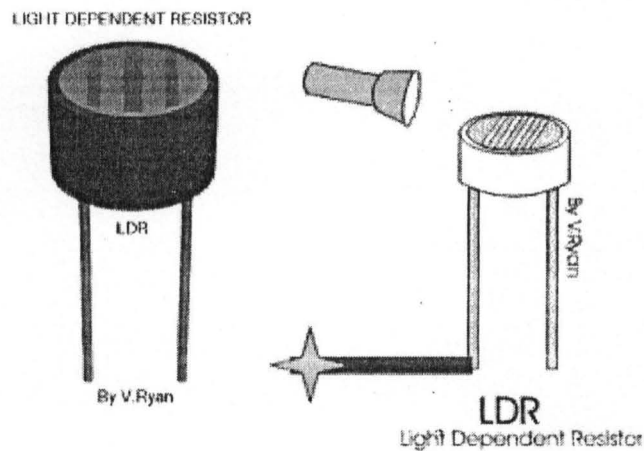

FIGURE 3.5 LIGHT DEPENDENT RESISTOR

This observation is illustrated in the figure below

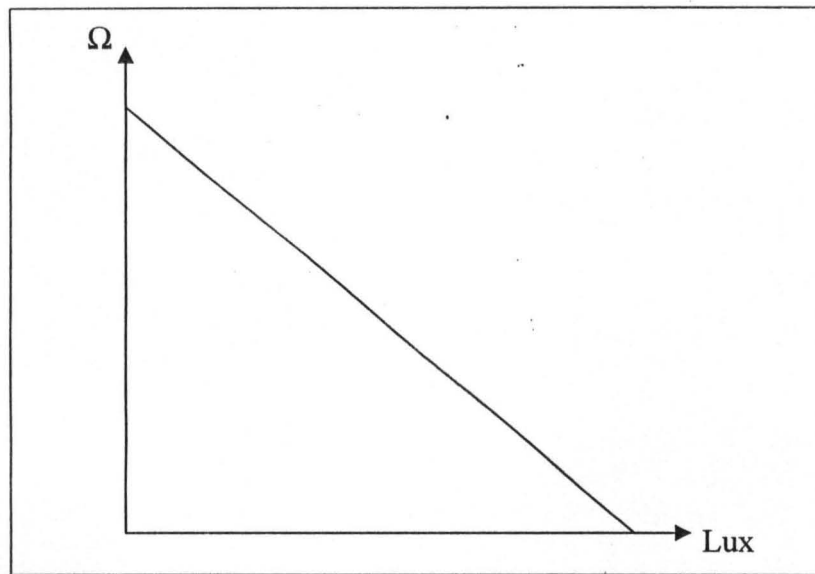

Figure 3.6 illustrating the relationship between the resistance and illumination of an LDR

3.23 THE VARIABLE RESISTOR

Resistors are one of the most common electronic components. A resistor is a device that limits, or resists current. The current limiting ability or resistance is measured in ohms, represented by the Greek symbol Omega (Ω).

There are two general ways in which the variable resistors are used. One is the variable resistor which value is easily changed, like the volume adjustment of Radio. The other is semi-fixed resistor that is not meant to be adjusted by anyone but a technician. It is used to adjust the operating condition of the circuit by the technician. Semi-fixed resistors are used to compensate for the inaccuracies of the resistors, and to fine-tune a circuit. The rotation angle of the variable resistor is usually about 300 degrees. Some variable resistors must be turned many times to use the whole range of resistance they offer. This allows for very precise adjustments of their value.

These are called "Potentiometers" or "Trimmer Potentiometers."

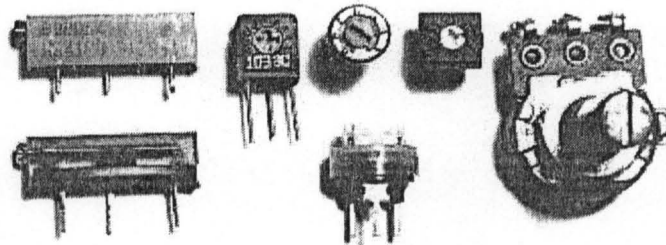

<http://www.fairchild.com>

FIGURE 3.7 VARIABLE RESISTORS

In the photograph to the left, the variable resistor typically used for volume controls can be seen on the far right. Its value is very easy to adjust. The four resistors at the center of the photograph are the semi-fixed type. These ones are mounted on the printed circuit board. The two resistors on the left are the trimmer potentiometers.

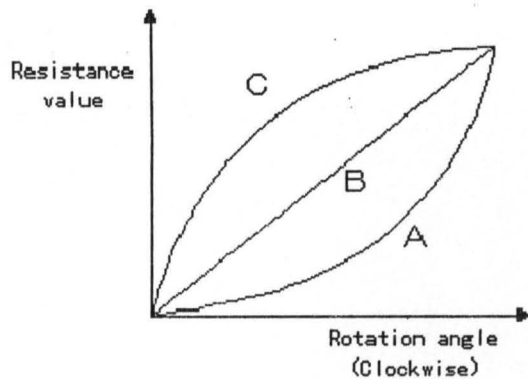

FIGURE 3.7 RESISTANCE VALUE VERSUS ROTATION ANGLE

There are three ways in which a variable resistor's value can change according to the rotation angle of its axis. When type "A" rotates clockwise, at first, the resistance value changes slowly and then in the second half of its axis, it changes very quickly. The "A" type variable resistor is typically used for the volume control of a radio, for example. It is well suited to adjust a low sound subtly. It suits the characteristics of the ear. The ear hears low sound changes well, but isn't as sensitive to small changes in loud sounds. A larger change is needed as the volume is increased. These "A" type variable resistors are sometimes called "audio taper" potentiometers.

As for type "B", the rotation of the axis and the change of the resistance value are directly related. The rate of change is the same, or linear, throughout the sweep of the axis. This type suits a resistance value adjustment in a circuit, a balance circuit and so on.

They are sometimes called "linear taper" potentiometers. Type "C" changes exactly the opposite way to type "A". In the early stages of the rotation of the axis, the resistance value changes rapidly,

and in the second half, the change occurs more slowly. This type isn't too much used. It is a special use. As for the variable resistor, most are type "A" or type "B".

Variable resistors (also called potentiometers or just "pots") are resistors that have a variable resistance. Resistance is adjusted by the turning a shaft. This shaft moves a wiper across the actual resistor element. By changing the amounts of resistor between the wiper connection and the connection (s) to the resistor element, the resistance can be changed. The resistance of resistors is often written with K Ω (kilo ohms) after the number value, this means that they are thousands of ohms. For example, 1Kilo Ω is 1000 ohm, 2Kilo Ω is 2000 ohm, 3.3Kilo Ω is 3300 ohm, etc. Resistors are also rated by their power handling capability. This is the amount of heat the resistor can take before it is destroyed. The power capability is measured in W (watts).

Common wattages for variable resistors are 1/8Watt, 1/4Watt, 1/2Watt and 1Watt. Anything of a higher wattage is referred to as a rheostat.

In this project work the variable resistor is used to preset or vary the voltage drop on the LDR such that the LDR voltage is the same supplied to the non inverting terminal of the comparator. The variable resistor is serving as a voltage divider.

3.30 THE SWITCHING UNIT

The switching unit is fed with the output of the comparator. This unit consists of a silicon transistor, serving as a switch/driver to the relay it has max collector current of 0.4 ampere, also present is the 12 volts relay used for closing the load circuit. The relay takes advantage of the fact that when electricity flows through a coil, it becomes an electromagnet. The electromagnetic coil

attracts a steel plate, which is attached to a switch. So the switch's motion (normally open and normally close) is controlled by the magnitude of current flowing to the coil.

A very useful feature of a relay is that it can be used to electrically isolate different parts of a circuit. It will allow a low voltage circuit (e.g. 12Volts DC) to switch the power in a high voltage circuit (e.g. 100 Volts AC or more).

The relay operates mechanically, so it cannot operate at high speed.

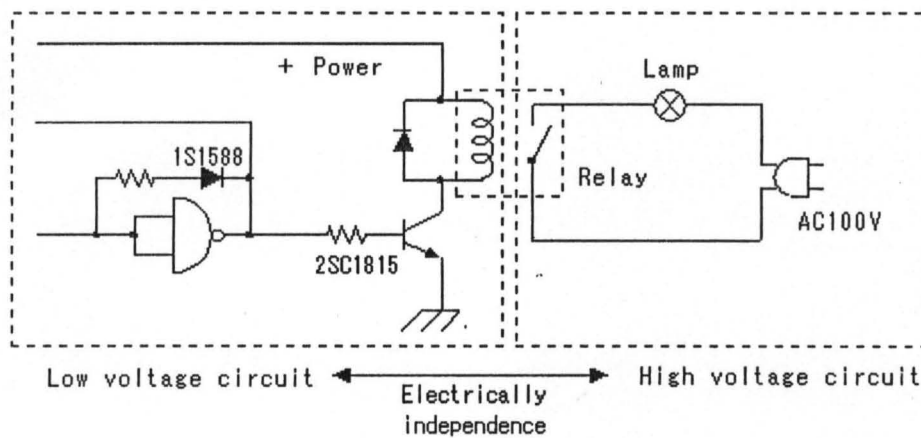

FIGURE 3.8 INTERNAL CIRCUIT OF RELAY

There are many kind of relays. The various things to consider when selecting a relay are its size, voltage and current capacity of the contact points, drive voltage, impedance, number of contacts, resistance of the contacts, etc.

The resistance voltage of the contacts is the maximum voltage that can be conducted at the point of contact in the switch. When this maximum rating is exceeded, the contacts will spark and melt, sometimes fusing together. The relay will fail. This rated value is usually printed on the relay.

To calculate for the value of the biasing resistor R_b

Voltage across the relay coil = 12 Volts

Internal resistance of relay coil = 253Ω

$$\text{Collector current } I_c = \frac{12V}{253\Omega}$$

$$I_c = 0.0474A$$

$$I_c = 47.4mA$$

$$\text{Hence, base current } I_b = \frac{I_c}{\beta}$$

$$\text{But } \beta = 100$$

$$I_B = \frac{0.0474}{100}$$

$$R_B = \frac{V_b - V_{be}}{I_B}$$

Where $V_B = 12$ Volts

$$I_B = 0.474mA$$

V_{BE} = forward voltage drop = 0.6 Volts

$$\text{Therefore } R_B = \frac{12 - 0.6}{4.74 \times 10^{-4}}$$

$$= 24035\Omega \approx 24K\Omega.$$

In the off state, the comparator has an offset voltage of 2 Volts. The resistor R_B drops this value which is sufficiently high enough to bias the transistor. It also protects the transistor.

During the ON State, the relay coil which is also an inductor stores energy it will discharge during the off state. Hence a free will diode is connected in parallel to it so it could discharge through it.

3.40 LOAD

The load consists of the conventional halogen lamps usually used in automobiles. The use of halogen lamps is gradually getting faced out due to advancement in modern design in automobile technology. This new design makes use of Light Emitting Diodes (LED) on a reflecting surface in place of the conventional halogen lamps. The advantage of this new technology is that the LED head lamp consumes less energy than the conventional halogen headlamps and LEDs are more economical since the problem of filament evaporation and melting is been eradicated. Due to the fact that the conventional halogen lamps are still widely used today, it is also used as the lamp (load) in this project work. The rating of the lamp is 12Volts, 150Watt

CHAPTER FOUR

CONSTRUCTION AND TESTING

4.0 CONSTRUCTION

In the course of realizing this device, the construction was initially carried out on a breadboard to allow for error checking and to ascertain that it is functioning effectively. All irregularities were corrected and then tested to have a satisfactory operation. The component were then removed and transferred to a Vero board strip and soldered into place. All discontinuous points were cut out to avoid short-circuiting.

4.1 TESTING

With the knowledge of the system operation the system was tested step by step to the relay output. The load was connected across its normally open terminal and its common terminal.

- a) Each component was checked before commencing the construction of the project.
- b) The potentiometer was adjusted at proper range.
- c) The battery used for testing was properly charged before it was installed.
- d) The components, that were not functioning properly, were change immediately they were discovered.

4.3 ASSEMBLING

The whole system was packed in a plastic casing and provision was made for the LDR to sense light from the outside. Also, a Green light emitting diode was used to indicate that the bright lamp is on, while the typical automobile halogen lamp was fixed to serve as the head lamp (bright/dim lamp). The halogen lamp was fixed into a plastic cone (rapped internally with aluminum foil) to help direct the light beam.

4.4 PRECAUTIONS

4.4.1 SOLDERING PRECAUTIONS

The construction was carried out with care. The precautions taken during the soldering were:

- a) The bit of soldering iron was kept clean with the help of a hand file from time to time.
- b) The soldering lead was of smaller gauge.
- c) Excess soldering lead was not use in other to avoid short circuiting in the conductive path.
- d) The overheating of components with the soldering iron was avoided to prevent component damage as a result of excessive heat.
- e) The leads of the components were kept clean before soldering, with the use of sand paper.

4.1.2 COMPONENTS PRECAUTION:

- a) LDR used should be sensitive. Before using in the circuit it was be tested with a multimeter.
- b) For safety and ease of replacement I.C socket was used also in other for the IC not to be heated much while soldering; too much heat can destroy the I.C., the use of I.C socket is suggested.
- c) While placing the I.C, the pins were plugged correctly into the socket.

- d) Opposite polarity of battery can destroy I.C, so polarity was check before switching ON the circuit. Diode was used in series with the switch for safety since diode allows flowing current in one direction only.
- e) Each component was soldered neatly and clean.

4.5 COMPONENT LIST

- a) R1 Photocell (1)
- b) RLY1: 12V Spdt (1)
- c) U1A: UA741 (1)
- d) U2: 7812 VOLTAGE REGULATOR (1)
- e) V1: 6V BATTERY (2)
- f) VS1: 9V BATTERY (2)
- g) Q1: BC574 NPN (1)
- h) D1: 1N4001 DIODE (1)
- i) D2: LED (1)
- j) R2: 1k RESISTOR (1)
- k) R3: 1k RESISTOR (1)
- l) R4,R5: 15k RESISTOR (2)
- m) R6: 50k RESISTOR (1)
- n) L1,L2: SINGLE CAR HALOGEN LAMP (1)

CHAPTER FIVE

CONCLUSION AND RECOMMENDATION

5.1 CONCLUSION

This report has provided details of the design as well as the components used in the realization of the project. After a careful design and construction, the project was tested and found to be successful.

The simplicity in of the design is own to the careful selection of materials employed, this equally results in the light net weight of the model. It is not only relatively cheaper and easy to maintain, the emergency light controller is very economical due to the low power consumption rate of Light Emitting Diode and effortless to operate without any human intervention.

5.2 RECOMMENDATION

As earlier stated that testing of the model was carried out using a 12volts 130/150 watt halogen lamp connected across the output of the 12 volt relay due to the popular use of halogen lamps in automobiles today, I would therefore, recommends that xenon lamps should can be interfaced with the devise to eliminate the large current supplied to the halogen lamp.

REFERENCES

- (1) Dalton R. Horn "Analogue Switches, Application and Project", First edition Tab books USA, pp 25 – 26
- (2) Lioned Warner "Electronics and Electrical Principles and Practice, "Second edition, Palgrave Malaysia, pp 71 – 72. 1998
- (3) Ralph J. Smith and Richard C. Darf, "Circuit, Devices and Systems" 5th edition, John Willey and Sons industries, Canada pp 94
- (4) Paul B-Zba, "industries Electronics" A text – laboratory manual third edition, Tata McGraw – Hill, New Delhi pp 42 – 44, 1993.
- (5) Theraja B.L. and Theraja A.K. "A Text book of Electrical Technology" Nirjia constructions and development company limited, Ram Nagar pp 1497, 1708 – 1709
- (6) www.datasheetcatalog.com
- (7) www.doctrionics.com
- (8) www.reuk.co.uk
- (9) www.eetimes.com
- (10) www.electronics-projct-design.com