

**DESIGN AND CONSTRUCTION OF A CURRENT  
SENSOR WITH TIMER**

**WODI AWYETU  
2005/22105EE**

**A PROJECT SUBMITTED TO THE DEPARTMENT OF  
ELECTRICAL AND COMPUTER ENGINEERING, FEDERAL  
UNIVERSITY OF TECHNOLOGY MINNA, NIGER STATE.**

**NOVEMBER 2010.**

## **DEDICATION**

I fondly dedicate this report to God's glory and blessing of mankind and to my parent Mr. & Mrs. Wodi T. Nathaniel and my younger ones for their support and prayer in my quest for knowledge.

## DECLARATION

I WODI AWYETU declares that this work was done by me and it has not been previously presented in any form whatsoever in any application for the award of a degree. I also hereby relinquish the copyright to the Federal University of Technology, Minna.

Wodi Awyetu  
(Project Student)

 01/11/2010

(Signature and Date)

Engr.M.Z.Adamu.  
(Project Supervisor)

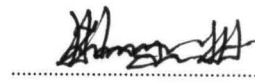
 14/09/2010

(Signature and Date)

Engr.A.G.Raji  
(Head of Department)

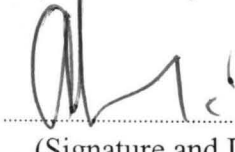
 (Jan. 11, 2011)

(Signature and Date)

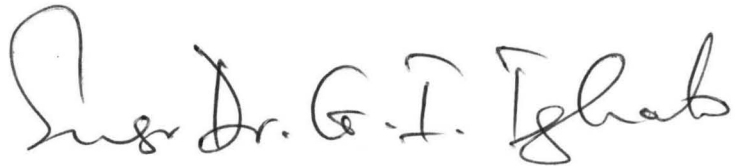

(External Examiner)

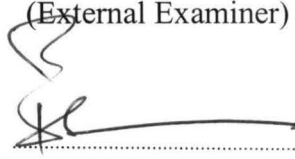
 6/12/10

(Signature and Date)

## ACKNOWLEDGEMENT

I wish to thank God Almighty who made everything possible for me through his divine guidance to complete this work successfully.

My sincere gratitude goes to my beloved parents Mr. & Mrs. Wodi T. Nathaniel for your immeasurable contributions both morally, spiritually and otherwise.

I will also not forget my wonderful sister Miss. Gladys A. Wodi, my brothers Alfred D. Wodi and Jones A. Wodi.

My profound gratitude goes to my project supervisor Engr. M. Z. Adamu for his effective contribution to this work who painstakingly took time to guide me through this work and also to Mr. Ajibuwa for his guidance towards this work.

I would like to thank Hon. & Mrs. Adams G. Nyisana for your encouragement, tremendous support and not forgetting Mr & Mrs. Azaki Yunana, Mr. & Mrs. Ishaka Simon, Hajiya (Mrs.) Uba Hassan Kuta, Miss Hauwa Ringo, Mr. Wodi Felix and my drama unit members E.C.A. Abuja, I deeply appreciate and thank you all.

Also to Christopher E. Kunini, Nana'ama R. Yeboah, Bolu Oluboye, Odili Anthony, Nwachukwu Henry, Tambe Pascal, Kate Ajuma, Doctor Gaji David, Seyi Adekoya, Dapo Soyemi, my classmates, I say thank you all for the guidance and support received from all of you who contributed to this project, your support and encouragement was vital for the success of the project, I am grateful and not forgetting my H.O.D. Engr. A.G. Raji and my lecturers of the department, God bless you all.



## ABSTRACT

High wattage appliances today continue to draw power when in use. Some while on standby losses electricity while waiting to be used. These losses from the appliances usually results to high cost of electricity bill. The only way to reduce the cost of electricity bill is to unplug the appliance after use. But due to human nature, some people tend to be carried away by doing something else forgetting that such appliance is running. This project; “the design and construction of a current sensor with timer provides the a device that reminds the user of the ‘on’ status of the device and the appliance connected through an LED, a time-out switch and a relay which automatically turns off the appliance and a beep to remind the user of time out. The device was developed by incorporating a power circuit that powers the device, a current sensing unit that senses the flow current in the appliance, a timer circuit that times the running of the appliance, a relay switch circuit that switches the appliance off connected to the device after time-out and a buzzer that reminds the user of timer-out.

# TABLE OF CONTENTS

	Pages
Title page	i
Dedication	ii
Declaration	iii
Acknowledgement	iv
Abstract	v
Table of Content	vi
List of figures	ix
List of tables	x
<b>CHAPTER ONE</b>	<b>1</b>
INTRODUCTION	1
1.0 current sensor	1
1.1 Aim and objectives	2
<b>CHAPTER TWO</b>	<b>4</b>
2.0 Literature review	4
2.1 AC current sensor overview	4
2.2 Transducer	7
2.2.1 Electrical Transducer	7
2.3 Development of Barium Strontium Titanate (BST) based sensor or instrument	9
2.4 Pyroelectric Sensor	11

2.5	Ferroelectric Sensor	11
2.6	Piezoelectric Sensor	12
2.6.	Principle of piezoelectric sensor operation.	13
2.7	PIC16F876	15
2.8	Analog-to-Digital Converters (ADC's)	16
2.9	Operational Amplifier(Op-amp)	16

**CHAPTER THREE** **19**

3.0	The project Division	19
3.1	Power Supply Unit	21
3.2	Full-Wave Bridge Rectifier	23
3.3	The Voltage Regulator Unit	24
3.4	Current Sensing Unit	24
3.5	Timer Unit	26
3.6	Relay Unit	27
3.7	The Indicator Unit	28
3.8	Output Unit	30
3.9	Switching Unit	30

**CHAPTER FOUR** **32**

4.0	Introduction	32
4.1	Construction	32
4.2	Testing	32
4.2.1	Power test	33

4.2.2	Timer's Output Test	33
4.3	Discussion of result	34
4.4	Limitation	34
<b>CHAPTER FIVE</b>		<b>35</b>
5.0	Conclusion	35
5.1	Recommendation	35
<b>REFERENCES</b>		<b>36</b>
Appendix 1		39

## LIST OF FIGURES

	Page
Fig. 2.1 Methodology of BST Thin-Film Fabrication	10
Fig. 2.2 Dual Operational Amplifier LM 358 in 8 Packaged	18
Fig. 3.1 Functional Block Diagram	20
Fig. 3.2 Power Supply Unit	21
Fig. 3.3 Bridge Rectifier Circuit	23
Fig. 3.4 Pin Assignment of 7805	24
Fig. 3.5 Current Sensor Unit	25
Fig. 3.6 Timer Circuit	26
Fig. 3.7 Relay Circuit	28
Fig.3.8 Indicator Unit	29
Fig. 3.9 Output Socket Terminal	30
Fig. 3.10 Switching Unit	31

**LIST OF TABLES**

	Page
Table 1.0 Power Test Result	33
Table 1.1 Timing Result	34

# CHAPTER ONE

## INTRODUCTION

### 1.0 INTRODUCTION

Sensing or controlling current flow is a fundamental requirement in many electronics systems and the techniques to do so are as diverse as the applications themselves [6]. It is an economical and reliable tool that is indispensable for monitoring equipment status, detecting process variation and ensuring personnel safety.

This control of electrically powered loads requires accurate, real-time status feedback [7]. However measuring the current input to equipment gives you more knowledge about actual equipment performance seeing load changes instantly can help improve throughput, reduce waste and prevent catastrophic equipment failure.

Current sensors are used in the power industry to measure current flowing in electrical system. Electrical current sensing is used in many applications. In particular, current sensors may be used in electrical switchgear such as circuit breakers and switches to determine when a fault has occurred in the electrical system. Current sensors for detecting dc currents have been widely used in variety of fields, such as home electric appliances (air conditioners, automatic washing machines, sewing machines, e.t.c.), industrial equipment and transport equipment.

There are two common methods used to sense the current. The first method detects and measures the current flowing in a conductor (inductive systems). The second method of current sensing uses a 'shunt' resistance in the current path to generate a voltage across

the shunt resistance in proportion to the current flowing. A variety of sensors are used to measure the amount of current flowing through a conductor. Eddy current sensors are known and are widely used in a variety of applications to detect and measure the characteristic of moving, electrically conductive objects. A common use of eddy current sensor is in fans and turbines, where the sensors are used to measure parameters related to blade status. A Hall Effect current sensor measures current flowing through a conductor and provides an output signal proportional to the level of current. Hall - effect current sensor offers several advantages over traditional current transformers such as a more compact size, higher current levels for a given size, and a larger frequency band width. AC current sensors typically comprises of inductive elements into which current is induced by the changing magnetic field surrounding an AC current carrying conductor.

Hence the device been constructed senses the flow of current in appliance being connected to it with a timer which shuts down the device after a specific period that is being set in order to reduce unnecessary power loss if left 'on' for hours unnoticed and gives audible beep when the time elapses with an indicator reminding the user of power 'on' status.

## **1.1 AIMS AND OBJECTIVES**

The project is aimed at the design and construction of a simple current sensing device with a timer for an electrical appliance in order to:

1. Monitor the performance of the appliance.
2. Reduce the rate of power consumption through the appliance.
3. Automatically switch off the appliance after the duration of time set.



4. Protect the appliance from unnecessary power loss and overheating.

# CHAPTER TWO

## LITERATURE REVIEW

### 2.0 INTRODUCTION

This chapter deals with the review of some related work, various types of current sensors and their various applications. These types of current sensors includes; AC current sensor such as current transformer, current sense amps, hall effect and magneto-resistive (MR) devices, Low-Side FET and DCR sensing circuits transducer's, development of barium strontium titanate (BST) based sensors, piezoelectric sensors, ferroelectric sensor, piezoelectric sensor, PIC16F876, analog-to-digital converters (ADC's), and operational amplifier (Op-Amp). These devices or type of sensors do not operate themselves. They are generally part of a larger system which could be either for measurement, data acquisition or process/device control.

### 2.1 AC Current Sensors

The most common types of ac current sensors found in SMPS systems include current sense transformers (CTs), differential current sense amps, Hall effect devices and direct current resistance (DCR) and low-side field-effect transistor (FET) sensing. The devices are commonly used to protect against over current conditions and/or provide current feedback information.

**Current Transformers:** - Use transformer action to reflect the current flowing from its primary to secondary circuits, where it is converted to a voltage by an external burden resistor. CTs have gained wide acceptance because they use a minimum number of external components, provide inherent isolation and are inexpensive. However, they are bulky magnetic components that contribute significant supply losses and have parasitic that complicate system design. In addition, they often require additional circuitry for core

reset. Many small CTs are still hand-wound, and suffer from mechanical integrity issues such as poor lead spacing uniformity. With the flux contained within the coil instead of passing through it, a direct relationship between the coil current and the current in the conductor generating the field was achieved and the current transformer was born [2,3].

**Current Sense Amps:** - Generate a voltage signal representative of current by measuring the voltage across a low-value series resistor. The resistor obviously creates power loss that grows more objectionable as current increases, and the amplifiers typically have relatively low bandwidth to limit noise. These characteristics make this technology best suited for low current dc and low frequency ac systems, and are often inappropriate for higher frequency and higher current switch mode applications [3].

**Hall Effect and Magneto-Resistive (MR) Devices:** - Operate by sensing the magnetic field generated by a current-carrying inductor and, consequently, offer low power loss. However, these devices tend to have low operating bandwidth, large size and high cost. They also tend to have small, noisy output signals and offset and temperature errors that degrade measurement accuracy [3]. There are two techniques for sensing current using Hall Effect devices. According to the Hall Effect, a magnetic field passing through a semiconductor resistor will generate a differential voltage proportional to the field. Concentric magnetic field lines are generated around a current carrying conductor.

Approximating the primary current conductor as infinitely long, the magnetic field strength may be defined  $B = \mu_0 I / 2\pi r$ , where  $\mu_0$  is the permeability of free space,  $I$  is the current and  $r$  is the distance from the center of the current conductor. In order to induce a larger signal out of the Hall element; the current conductor may be wrapped around a

slotted ferrous toroid  $N$  number of times, such that  $B = \mu_0 NI / 2pr$ . In an open loop topology, the Hall element output is simply amplified and the output is read as a voltage that represents the measured current through a scaling factor as depicted. In a closed loop topology, the output of the Hall element drives a secondary coil that will generate a magnetic field to cancel the primary current field. The secondary current, scaled proportional to the primary current by the secondary coil ratio can then be measured as voltage across a sense resistor. By keeping the resultant field at zero, the errors associated with offset drift, sensitivity drift and saturation of the magnetic core will also be effectively canceled [10].

Closed-loop Hall effect current sensors also provide the fastest response times. However, with a secondary coil that may be needed to drive up to several milli-amps of current, power consumption is much higher in closed loop Hall Effect devices than open loop topologies. The closed loop configuration also limits the magnitude of the current that can be sensed since the device may only drive a finite amount of compensation current [10].

**Low-Side FET and DCR Sensing Circuits:** - Both sense the voltage across a resistance already in the circuit, so they add virtually no loss of their own. In the case of DCR sensing, an RC circuit across the output filter makes the combined circuit appear as a resistor. An amplifier connected across this “virtual resistor” measures current the same way as the resistor/sense amp scheme series described earlier. Like DCR, low-side FET sensing also measures the voltage across a resistor, but uses the low-side transistor  $R_{DS(ON)}$  as the sense resistor. While both methods use a relatively large number of commodity op-amps and passives, they remain among the lowest cost, lowest loss

techniques in use today. On the down side, these approaches suffer from large installed size and sometimes require the added cost of system calibration to address high measurement error – sometimes as high as  $\pm 40\%$  [3].

## **2.2 TRANSDUCER**

A transducer is defined as a device that receives energy from one system and transmits it to another, often in a different form. Broadly defined, the transducer is a device capable of being actuated by an energizing input from one or more transmission media and in turn generating a related signal to one or more transmission systems. It provides a usable output in response to a specified input measurand, which may be a physical or mechanical quantity, property, or conditions. The energy transmitted by these systems may be electrical, mechanical or acoustical [9].

The nature of electrical output from the transducer depends on the basic principle involved in the design. The output may be analog, digital or frequency modulated. Basically, there are two types of transducers, electrical, and mechanical.

### **2.2.1 Electrical Transducer**

An electrical transducer is a sensing device by which the physical, mechanical or optical quantity to be measured is transformed directly by a suitable mechanism into an electrical voltage or current proportional to the input measured. An electrical transducer must have the following parameters:

**i. Linearity**

The relationship between a physical parameter and resulting electrical signal must be linear.

**ii. Sensitivity**

This is defined as the electrical output per unit change in the physical parameter (for example  $V/^{\circ}C$  for a temperature sensor). High sensitivity is generally desirable for a transducer.

**iii. Dynamic Range**

The operating range of transducer should be wide, to permit its use under a wide range of measurement conditions.

**iv. Repeatability**

The input or output relationship for a transducer should be predictable over a long period of time. This ensures reliability of operation.

**v. Physical Size**

The transducer must have minimal weight and volume, so that its presence in the measurement system does not disturb the existing conditions. The main advantages of electrical transducers (conversion of physical quantity into electrical quantities) are as follows:

- a. Electrical amplification and attenuation can be easily done.
- b. Mass-inertia effects are minimized.
- c. Effects of friction are minimized.

- d. The output can be indicated are recorded remotely at a distance from the sensing medium.
- e. The output can be modified to meet the requirements of the indicating or controlling units. The signal magnitude can be related in terms of the voltage current.
- f. The signal can be conditioned or mixed to obtain any combination with outputs of similar transducers or control signals.
- g. The electrical or electronic system can be controlled with a very small power level.
- h. The electrical output can be easily used, transmitted and processed for the purpose of measurement.

### **2.3 DEVELOPMENT OF BARIUM STRONTIUM TITANATE (BST) BASED SENSORS OR INSTRUMENTS.**

Research deals with the development of Barium Strontium Titanate or simply BST based micro-sensors or instruments such as heat, optical and gas sensors or instruments.

The pyroelectric sensing capability of a Barium Strontium Titanate (BST) element is demonstrated in the form of a heat detector. Presence of an abnormal heat source triggers an alarm. The optical sensing capability of Barium Strontium Titanate (BST) element is demonstrated in the form of an optical switch. The Barium Strontium Titanate (BST) sensor detects the ambient light level. If it falls below the set threshold switches on a light.

Out future research is geared toward complex sensor by combining various sensing properties and micro-fabrication using lithography and other techniques. The obtained

BST thin-film show ferroelectric, pyroelectric, piezoelectric and electro-optic properties. The oxides are chemically stable in the atmosphere. Barium Strontium Titanate (BST) thin-film was deposited on P-si (100) by spins coating technique which has advantage of simplicity and low cost. The Figure 2.1 shows the methodology in preparation of Barium Strontium Titanate (BST) thin-film.

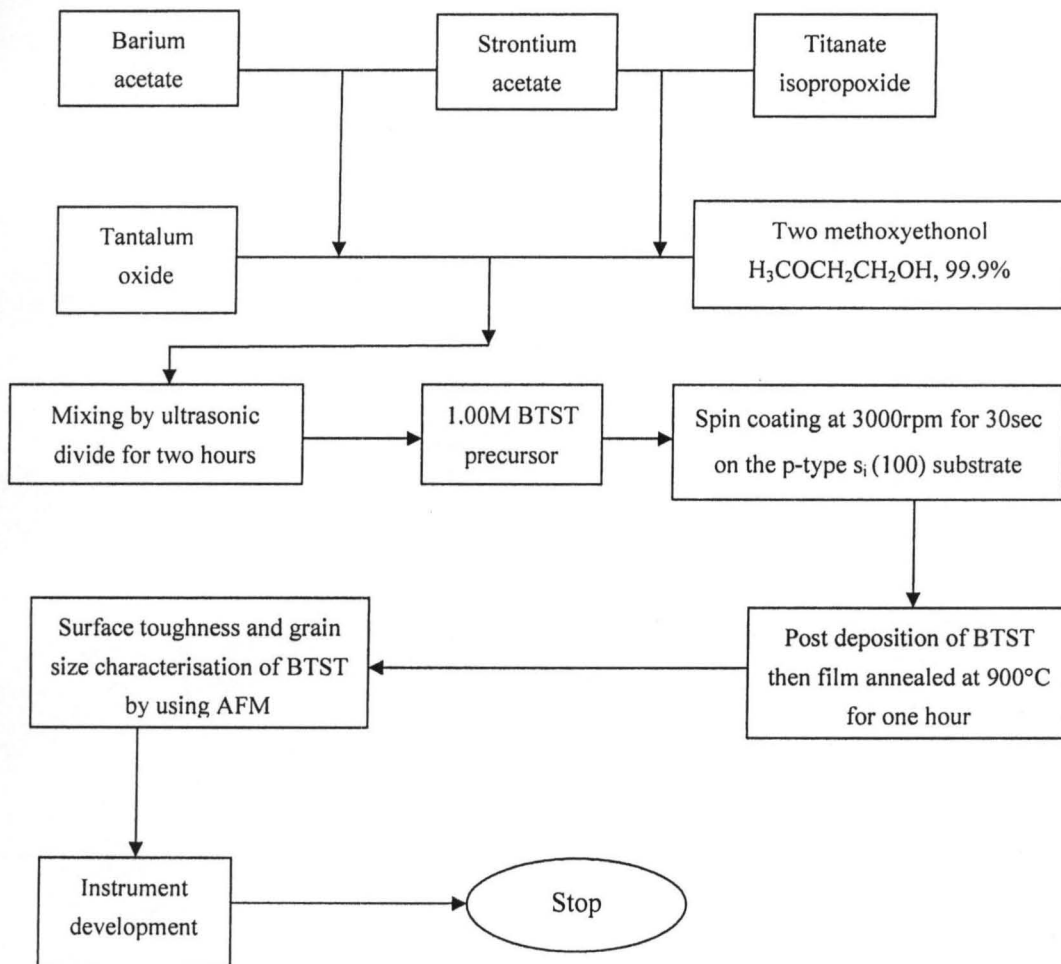

**Fig. 2.1: Methodology of the BST thin-film fabrication.**



## **2.4 PYROELECTRIC SENSOR**

An improved, selective, radiation sensing device is provided which includes a thin strip of pyroelectric material. One side of the material is coated with a continuous layer of metallic material to form an electrode while the opposite side is coated with at least a pair of electrodes and the output of the electrodes are electrically connected to a differential amplifier. A layer of energy filter material is applied over the continuous electrode. This layer is transparent to all energy outside of a desired energy frequency band to which the device is to be sensitive but absorbs and converts to heat all energy applied which is within this band. This heat is conducted quickly into the pyroelectric material which produces a voltage change in the output from the corresponding electrodes. By positioning the device at the focal point of a concave mirror, the output from the electrodes can be used to energize an alarm signal or the magnitude and frequency of the output of the device can indicate the size and movement of an energy source such as a human body. A novel method of making the device is included which facilitates the fabrication and reduces handling problems and costs

## **2.5 FERROELECTRIC SENSOR**

In physics, the ferroelectric effect is an electrical phenomenon whereby certain materials may exhibit a spontaneous dipole moment, the direction of which can be switched between equivalent states by the application of an external electric field. The term ferroelectricity is used in analogy to ferromagnetism, in which a material exhibits a permanent magnetic moment.

There are two main types of ferroelectrics: displace and order-disorder. The effect in Barium Titanate, a typical ferroelectric of the displace type, is due to a polarization

catastrophe, in which, if an ion is displaced from equilibrium slightly, the force from the local electric fields due to the ions in the crystal increase faster than the elastic-restoring forces. This leads to an asymmetrical shift in the equilibrium ion positions and hence to a permanent dipole moment. In an order-disorder ferroelectric, there is a dipole moment in each unit cell, but at high temperatures they are pointing in random directions. Upon lowering the temperature and going through the phase transition, the dipoles order, all pointing in the same direction within a domain. Ferroelectrics often have very large dielectric constants, and thus are often used as the dielectric material in capacitors. They also often have unusually large nonlinear optical coefficients

## **2.6 PIEZOELECTRIC SENSOR**

Piezoelectric sensor is a device that uses the piezoelectric effect to measure pressure, acceleration, strain or force by converting them to an electrical signal. Piezoelectric sensor has proven to be versatile tools for the measurement of various processes. They are used for quality assurance, process control and process development in many different industries. Piezoelectric sensors are also seen in nature. Bones act as force sensors. Once loaded, bones produce charges proportional to the resulting internal torsion or displacement. Those charges stimulate and drive the build up of new bone material. This leads to the strengthening of structures where the internal displacements are the greatest. With time, this causes weaker structures to increase their strength and stability as material is laid down proportional to the forces affecting the bone.

The rise of piezoelectric technology is directly related to a set of inherent advantages. The high modulus of elasticity of many piezoelectric materials is comparable to that of many metals and goes up to  $105 \text{ N/mm}^2$ . Even though pyroelectric sensors are electromechanical systems that react on compression, the sensing elements show almost

zero deflection. This is the reason why piezoelectric sensors are so rugged, have an extremely high natural frequency and an excellent linearity over a wide amplitude range. Additionally, piezoelectric technology is insensitive to electromagnetic fields and radiation, enabling measurements under harsh conditions. Some materials used (especially gallium phosphate or tourmaline) have an extreme stability over temperature enabling sensors to have a working range of up to 1000°C. Tourmaline shows pyroelectricity in addition to the piezoelectric effect; this is the ability to generate an electrical signal when the temperature of the crystal changes. This effect is also common to piezoceramic materials.

One disadvantage of piezoelectric sensors is that they cannot be used for true static measurements. A static force will result in a fixed amount of charges on the piezoelectric material. Working with conventional readout electronics, not perfect insulating materials, and reduction in internal sensor resistance will result in a constant loss of electrons, yielding a decreasing signal. Elevated temperatures cause an additional drop in internal resistance; therefore, at higher temperatures, only piezoelectric materials that maintain a high internal resistance can be used. Anyhow, it would be a misconception that piezoelectric sensors can only be used for very fast processes or at ambient conditions. In fact, there are numerous applications that show quasi-static measurements while there are other applications that go to temperatures far beyond 500°C.

### **2.6.1 Principle of Piezoelectric Sensor Operations**

Depending on how a piezoelectric material is cut, three main modes of operations can be distinguished: transverse, longitudinal, and shear.

i. **Transverse effect**

A force is applied along a neutral axis(y) and the charges are generated along the (x) direction, perpendicular to the line of force. The amount of charge depends on the geometrical dimensions of the respective piezoelectric element. When dimensions a, b, c apply,

$$C_x = \frac{d_{xy} F_y b}{a}$$

Where;

*a is the dimension in line with the neutral axis*

*b is in line with the charge generating axis*

*d is the corresponding piezoelectric coefficient*

ii. **Longitudinal effect**

The amount of charge produced is strictly proportional to the applied force and is independent of size and shape of the piezoelectric element. Using several elements that are mechanically in series and electrically in parallel is the only way to increase the charge output. The resulting charge is;

$$C_x = d_{xx} F_x n$$

Where;

*d is the piezoelectric coefficient for a charge in x-direction*

*released by forces applied along x-direction (in pC/N).*

*F is the applied Force in x-direction [N].*

*n* is corresponds to the number of stacked elements.

### iii. Shear effect

Again, the charges produced are strictly proportional to the applied forces and are independent of the element's size and shape. For *n* elements mechanically in series and electrically in parallel the charge is

$$C_x = 2d_{xx}F_x n$$

In contrast to the longitudinal and shear effects, the transverse effect opens the possibility to fine-tune sensitivity on the force applied and the element dimension.

## 2.7 PIC16F876

This is one of the newest groups of devices from Microchip. They have flash program memory so they can be reprogrammed over and over again. Their building block is identical to the PIC16C7X family with some data memory and program memory updates. They offer 22 to 33 I/O, three timers and up to 8k of program memory. They have all the special functions PIC16C6X and PIC16C7X parts have as mentioned earlier.

All the projects built around the PIC16F876 because it is flash reprogrammable and has A/D, and has all the other PIC features. It is also offers the option to build a boot-loader inside. A boot-loader allows me to program the part from a serial port without any special programmer circuitry.

## **2.8 ANALOG –TO- DIGITAL CONVERTERS (ADCs)**

An analog-to-digital converter, or simply ADC, is a semiconductor device that is used to convert an analog signal into a digital code. In the real world, most of the signals sensed and processed by humans are analog signals. Analog-to-digital conversion is the primary means by which analog signals are converted into digital data that can be processed by computers for various purposes.

An analog signal is a signal that may assume any value within a continuous range. Examples of analog signals commonly encountered every day are sound, light, temperature, and pressure, all of which may be represented electrically by an analog voltage or current. A device that is used to convert an analog signal into an analog voltage or current is known as a transducer. An analog-to-digital converter is used to further translate this analog voltage or current into digital codes that consist of 1's and 0's [11].

A typical ADC, therefore, has an analog input and a digital output, which may either be 'serial' (consisting of just one output pin that delivers the output code one bit at a time) or 'parallel' (consisting of several output pins that deliver all the bits of the output code at the same time). Analog-to-digital converters come in many forms.

## **2.9 OPERATIONAL AMPLIFIER (OP-AMP)**

An operational amplifier is a dc amplifier having a high gain, of the order  $10^4$  – $10^8$ . The operational amplifier is arguably the most useful single device in analog electronic circuitry. With only a handful of external components, it can be made to perform a wide variety of analog signal processing tasks. It is also quite affordable; most general-purpose

amplifiers sell for under a dollar apiece. Modern designs have been engineered with durability in mind as well: several "op-amps" are manufactured that can sustain direct short-circuits on their outputs without damage [1].

One key to the usefulness of these little circuits is in the engineering principle of feedback, particularly negative feedback, which constitutes the foundation of almost all automatic control processes. The principles presented here in operational amplifier circuits, therefore, extend well beyond the immediate scope of electronics. It is well worth the electronics student's time to learn these principles and learn them well.

The two input leads can be seen on the left-hand side of the triangular amplifier symbol, the output lead on the right-hand side, and the +V and -V power supply leads on top and bottom. As with the other example, all voltages are referenced to the circuit's ground point. Notice that one input lead is marked with a (-) and the other is marked with a (+). Because a differential amplifier amplifies the difference in voltage between the two inputs, each input influences the output voltage in opposite ways. The formula for gain and voltage output equation show below:

$$\text{Gain} = R_F / R_{IN}$$

$$V_{OUT} = A_V (V_{IN1} - V_{IN2})$$

An increasingly positive voltage on the (+) input tends to drive the output voltage more positive, and an increasingly positive voltage on the (-) input tends to drive the output voltage more negative. Likewise, an increasingly negative voltage on the (+) input tends to drive the output negative as well, and an increasingly negative voltage on the (-) input does just the opposite. Because of this relationship between inputs and polarities, the (-) input is commonly referred to as the inverting input and the (+) as the non-inverting input.

Some models of op-amp come two to a package, including the popular models LM358. These are called "dual" units, and are typically housed in an 8-pin DIP package as well, with the following pin connections.

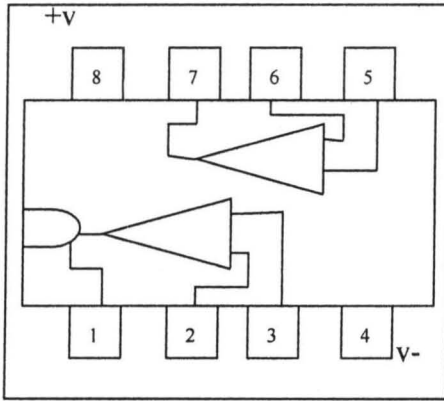

**Fig. 2.2: Dual operational amplifier LM358 in 8-package.**



# **CHAPTER THREE**

## **DESIGN AND IMPLEMENTAION**

### **3.0 INTRODUCTION**

The main realization of the entire work lies on this chapter; design of the various units of the system build up, the theory of operations as discussed in the previous chapter. The design is also based on the availability and cost implication of components to be used for the realization of this project.

### **3.1 THE PROJECT DIVISION**

The overall project has been grouped into nine (9) main sections. Each section is taken and explained one after the other. The grouping is therefore as follow:

1. Power supply unit.
2. The current sensing unit.
3. Full-wave bridge rectifier.
4. Power indicator unit.
5. The voltage regulator unit.
6. Timer circuit.
7. Switching unit.
8. Relay unit.
9. Output unit.

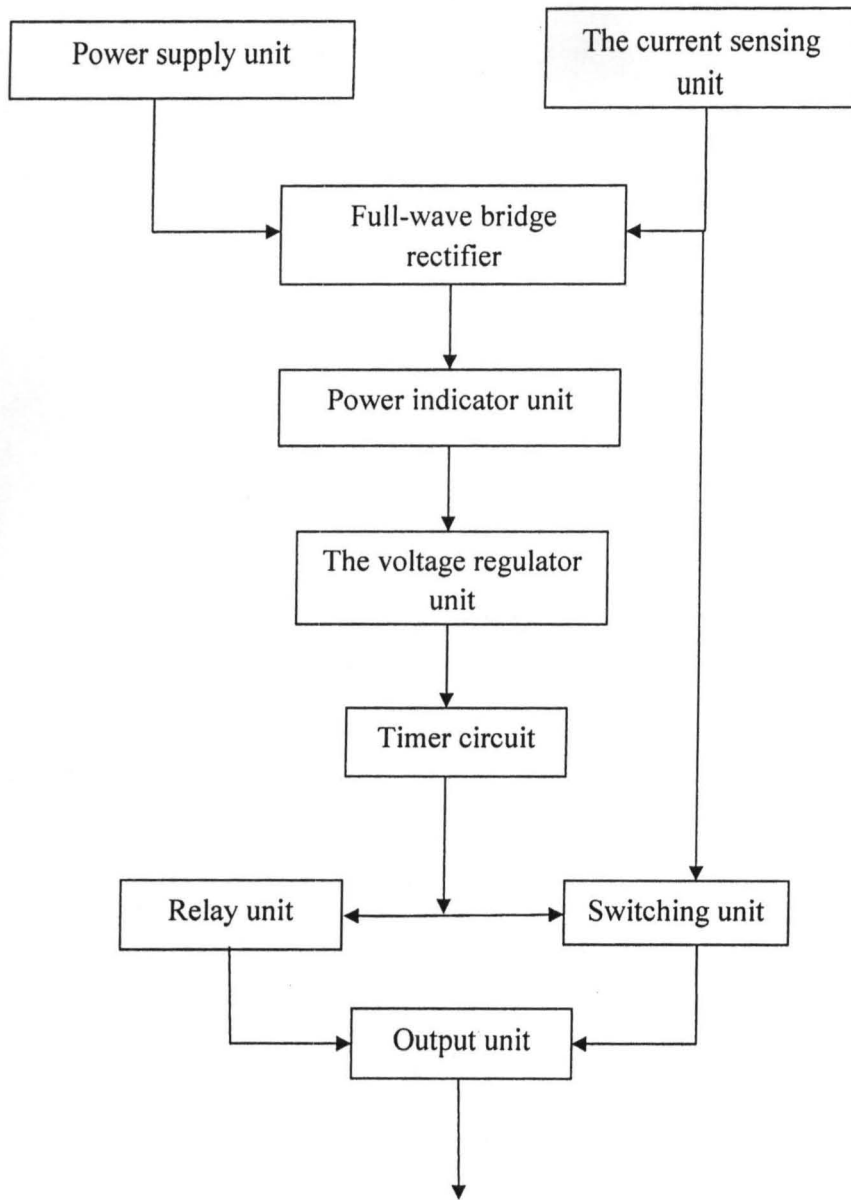

**Figure 3.1 Functional block diagram.**

### 3.2 POWER SUPPLY UNIT

The power supply unit consist of a 12V, 0.5A step-down transformer wired to a full-wave bridge rectifier and a voltage regulator of 5 volts as shown below:

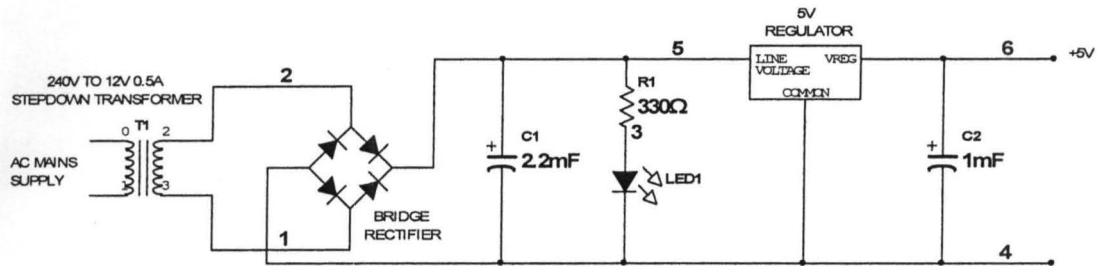

Fig. 3.2 Power supply unit.

$$V_{peak} = [V_{rms}\sqrt{2} - 1.4]$$

Where:  $V_{rms}$  = secondary ac voltage.

$\sqrt{2}$  = rms-to-peak scaling factor.

1.4 = 2 diode forward voltage.

$$\text{Therefore; } V_{peak} = 12\sqrt{2} - 1.4$$

$$= 16V.$$

The value of the capacitor connected for smoothening the voltage evaluated using the

Formula below:

$$Q = CV = IT$$

Where: C = value of smoothening capacitance.

$V$  = maximum value of ac ripple voltage.

$I$  = maximum load current = 500mA.

$T = \frac{1}{2}$  (full-wave bridge rectifier).

$F$  = main frequency = 50Hz.

Therefore:

$$C = \frac{IT}{V} = I \times \frac{1}{2}$$

The 7805 regulator requires a minimum input voltage of 7V to maintain regulation. So

therefore, 2V peak-to-peak ac ripple voltage was fixed.

$$C = \frac{IT}{V} = 0.05 \times \frac{1}{(2 \times 50)/2}$$

$$= 0.05 \times 0.01/2$$

$$= 0.00025f$$

$$= 2500\mu f$$

Hence a 2200 $\mu$ f, 25volt was used for the smoothening capacitance.

### 3.3 FULL-WAVE BRIDGE RECTIFIER

This is used to convert an alternating current (AC) on secondary winding of the transformer to an equivalent direct current (DC) voltage required by the circuit. The rectifier is made up of four (4) diodes (D1, D2, D3 and D4). The diodes D2 and D4 are connected in forward biasing mode while the diodes D1 and D3 are connected in reverse biasing mode. These diodes D2 and D4 allow the flow of current through them which result in positive terminal and the diodes D1 and D3 blocks the flow of current through them so we have negative terminal. Figure 3.2 shows the connection of the diodes

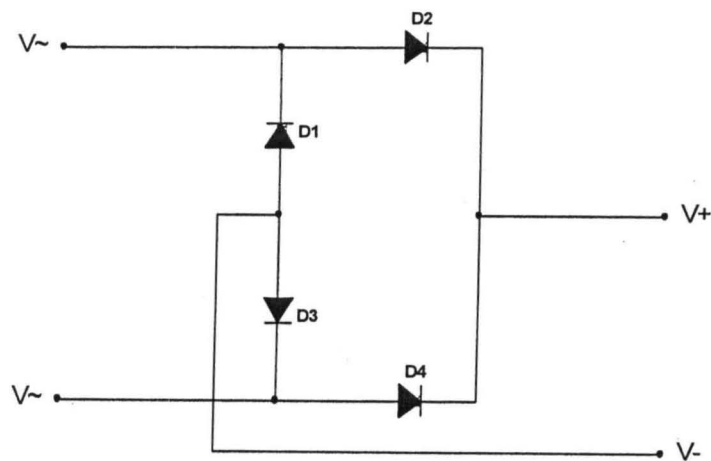
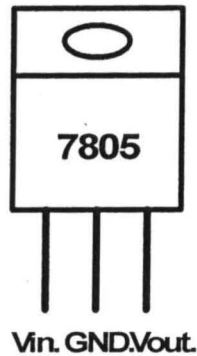

**Fig. 3.3 Bridge rectifier circuit.**

From the figure 3.2,  $V_{\sim}$  represents the output of the transformer while  $V_{+}$  and  $V_{-}$  feed a capacitor. The addition of a capacitor may be important because the bridge alone supplies an output voltage of fixed polarity magnitude.

### 3.4 THE VOLTAGE REGULATOR UNIT

The 7805 regulator is a 5volt, 1amp regulator with the pinning shown in the figure 3.3 below.



**Fig. 3.4 Pin assignment of 7805.**

The regulator was connected across the smoothening capacitor to regulate the 16V to a 5V at a maximum load current of 1Ampere in which the output was stabilised using a 1000 $\mu$ f, 16V capacitance fed to the circuit.

### 3.5 CURRENT SENSING UNIT

The type of sensor used in this section is a current transformer. The transformer monitors the current flowing into the circuit when a load is connected to the device. The secondary of the current transformer is rectified by a full-wave bridge rectifier D1 through D4 and smoothened by a 1000 $\mu$ f capacitance.

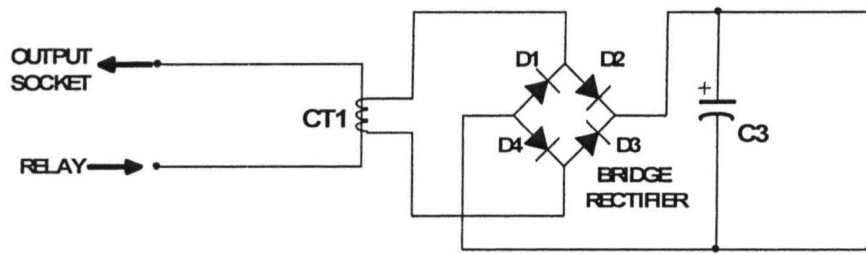

Fig. 3.5 Current sensor unit.

The current transformer ratio used is ratio 1:30. The load current flows through the primary winding, and the secondary current and the terminal voltages of the two winding are practically proportional to the primary current.

Hence:

$$\frac{V_2}{V_1} \cong \frac{N_2}{N_1} \cong \frac{I_1}{I_2}$$

Thus, if the full load power demand is 1000W at 220V, the current therefore will be determined by;

$$P = IV$$

Therefore;

$$1000 = 200I$$

$$I = \frac{1000}{220}$$

$$= 4.5$$

$$\cong 5A$$

### 3.6 TIMER UNIT

In this section a 555 timer was used connected in its monostable state (one-shot) of operation. This produces a single output pulse when triggered. The duration of the pulse is called the time period (T) and this is determined by variable resistor VR1 and capacitor C1 as shown in the figure below.

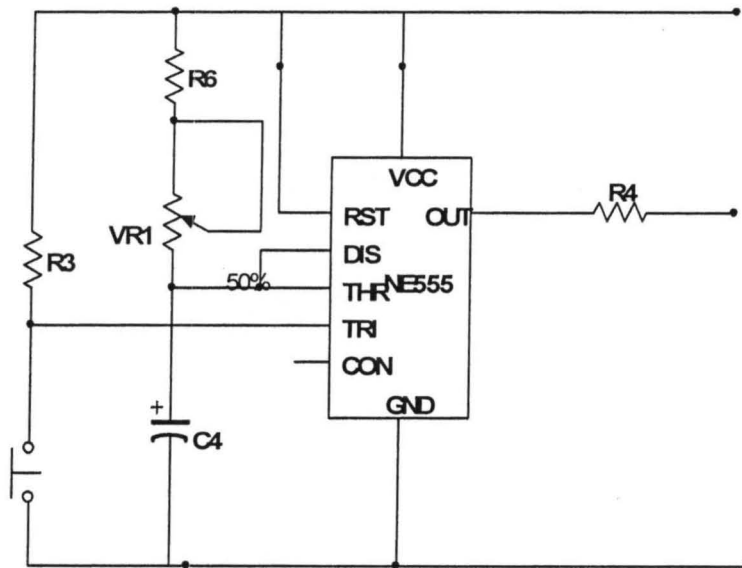

Fig. 3.6 Timer circuit.

Time period:

$$T = 1.1VR_1C_4$$

Where: T = time period in seconds (s).

VR1 = variable resistance in ohms ( $\Omega$ ).

C1 = capacitance in farads (F).



1.1 = time constant the capacitor will reach  $\frac{2}{3} V_{CC}$  level  $\cong 67\%$ .

The timing capacitor  $C_4$  was picked to be  $470\mu\text{f}$  and  $T = 5\text{min}$ .

For  $T$  (in seconds) =  $5\text{min}$

$$T = 5 \times 60 = 300\text{sec}$$

Therefore:

$$300\text{sec} = 1.1 \times VR_1 \times 470\mu\text{f}$$

$$VR_1 = \frac{300}{1.1 \times 470 \times 10^{-6}}$$

$$VR_1 = 580\text{k}\Omega$$

Hence a  $700\text{k}\Omega$  resistor was used as the timing resistor.

### 3.7 RELAY UNIT

A relay is an electrically operated switch that allows a small current circuit to control a higher current circuit. The relay used is a 6volts relay with a protection diode connected to it to prevent the relay from damaging. The relay switch connections are shown figure below; the connections are usually labelled COM, NC and NO:

☐ COM = Common.

☐ NC = Normally Closed.

☐ NO = Normally Open.

The control circuit of the relay is the 555Timer which sends an output current of 200mA which is amplified by the transistor T1. The relay action occurs when it is energised by the timer; the current from the timer is then amplified by the NPN transistor connected to the relay. The relay now automatically switches off the load connected to it.

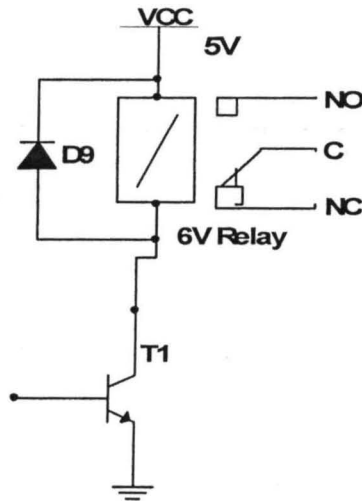

Fig. 3.7 Relay circuit.

### 3.8 THE INDICATOR UNIT

The indicator shows the status of the device in operation.

1. The ON state of the device; when the device is switched on.
2. The load status; when an output device is connected. And
3. The no load status; when there is no device connected.

The LEDs were driven via a current-limiting resistor, the value of which was calculated using the below equation:

$$R_s = V_s - \frac{V_{LED}}{I_{LED}}$$

Where;  $V_S$  = System supply voltage = 5V.

$V_{LED}$  = Voltage across the LED = 2V.

$I_{LED}$  = Current flow through the LED = 10Ma Nominal.

Therefore:

$$R_S = 5 - \frac{2}{0.01}$$

$$= 330\Omega$$

A 330 $\Omega$  resistor was used as the limiting resistor connected in series to the LED.

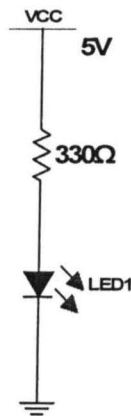

**Fig. 3.8 Indicator unit.**

### 3.9 OUTPUT UNIT

The output of the device is a 13Amps socket outlet in which a load is to be connected to and the current drain is being monitored by the current transformer. The terminal connection is as shown below:

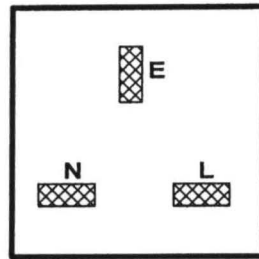

**Fig. 3.9 Output socket terminal.**

This section also consists of the peizobuzzer which gives an audible output indicating time-out which brings to the notice of the user the status of the appliance.

### 3.10 THE SWITCHING UNIT

This unit comprises of four (4) transistors connected together to achieve the following:

$Q_1$  is in series with a limiting resistor in order to protect the transistor which amplifiers the output pulse from the 555 timer and give a high input to the relay.  $Q_2$  and  $Q_3$  show an integrated TTL NAND gate in which the inputs to both transistors goes high when there is an output from  $Q_1$  and a current drain from the current transformer respectively. This

circuit switches the buzzer when timed-out and the indicator that shows the 'on' status of the appliance connected.

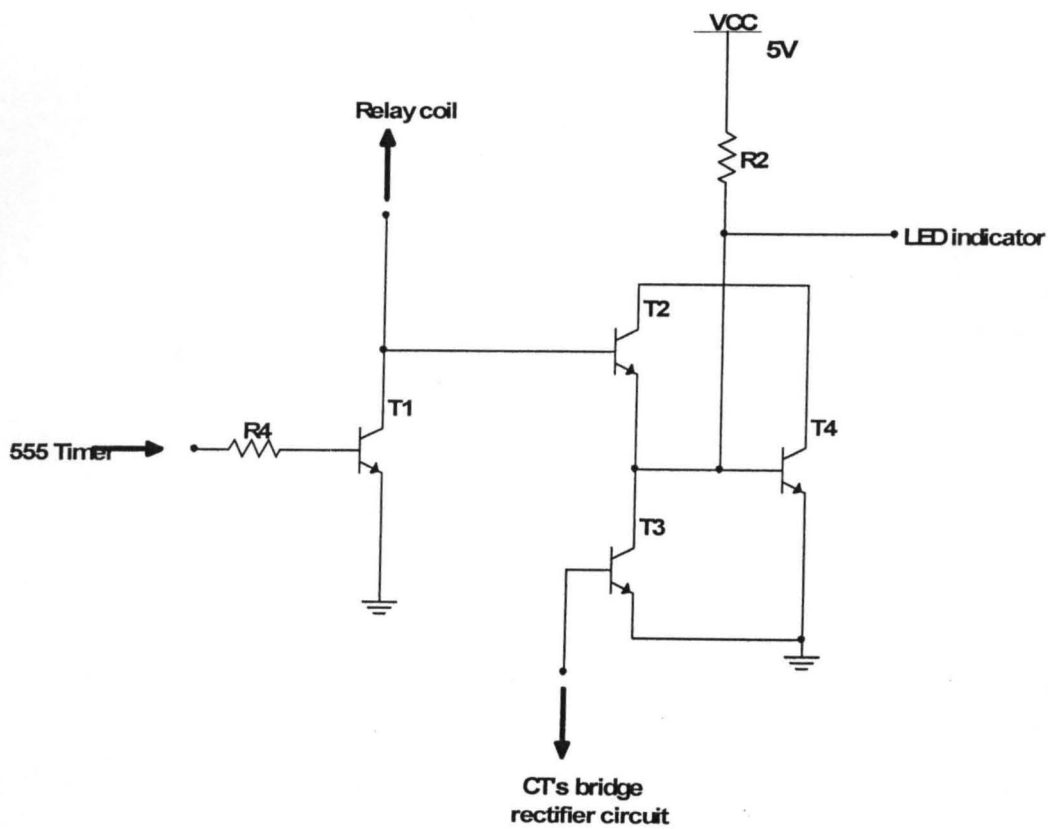

Fig. 3.10 The switching unit

# CHAPTER FOUR

## TEST, RESULTS AND DISCUSSION

### 4.0 INTRODUCTION

This chapter is one of important step during the cause of the project. It contains brief explanation of the construction work, testing and measurement of the project work. The results obtained are properly noted and recorded in tabular form and the results so obtained are discussed below.

### 4.1 CONSTRUCTION

The construction of the device was carried out after the purchase of the various components needed. This was aided by the use of the circuit diagram which was drawn in steps with circuitry design software known as “work bench”. The construction followed the steps as stated in the design/block diagram. These steps been followed were soldered to a project board (Vero board).

### 4.2 TESTING

The following steps were taking in testing the device after the construction of the device which includes:

- Power test.
- Timer's output pulse test.

#### 4.2.1 Power test

This test was carried out to check for the circulation of power in system device. The power cord was plugged to a power source connecting the power transformer and the voltage across C2 was measured and recorded.

#### 4.2.2 Timer's output test

The test was conducted to determine the output pulse durations by varying the variable resistor so as to indicate the range of pulse duration that was able to attain.

The results obtained are tabulated below:

**Table 1.0 Power Test Result**

S/no.	Power test	Approximated value obtained.
1.	Power transformer input voltage	240V
2.	Power transformer output voltage	12V
3.	Voltage across capacitor C1	5V

**Table 1.1 Timing Result**

S/no	Timing resistor		Timing capacitor ( $\mu\text{f}$ )	Measured pulse width (s)
	VR1 ( $\text{k}\Omega$ )	R( $\text{k}\Omega$ )		
1.	100	600	470	361.900

### **4.3 DISCUSSION OF RESULT**

From the results obtained, it was seen that the current transformer sensed the current drained by the appliance plugged to the device which also is proportional to the voltage.

In general, it was seen that the calculated values and the measured values showed a significance of a negative tolerance in value which could be seen as an error during construction especially, the output pulse from the timer circuit that was observed, showed a fraction of 50% - 60% tolerance which makes it not suitable for longer timing.

### **4.4 LIMITATION**

1. The timing capacitor used is an electrolytic capacitor which the values are not accurate due to leakage of charge giving an error of at least 20%.
2. The draw back for the current transformer is the increase in size, cost and portion of current which it senses.



## CHAPTER FIVE

### CONCLUSION AND RECOMMENDATION

#### 5.0 CONCLUSION

The number of applications requiring current sensing continues to expand depending on the demand of application. It shows that the new device worked properly and gave satisfactory results. The results indicate that it is necessary to put emphasis in the monitoring of high wattage appliances. In addition, it was seen that the current transformer used sensed a fraction of the high inductor current by using the mutual inductor properties of the transformer. They are economical and reliable tools for monitoring equipment status, detecting process variations, and ensuring personnel safety.

#### 5.1 RECOMMENDATION

I recommend that a research programme or a course on research should be introduced in lower levels before the final year project to expose the student's forehead as a pre-project work for better understanding in order to carry out an outstanding final year project work.

I also recommend that further improvement to this work should be carried out in the following areas:

1. The current sensing unit: a better means should be devised in order to monitor the current with minimal losses.

2. The timer circuit: the timer circuit should be arranged in such a way that it could last for longer time or better mode of timing should be developed to serve appliances that require longer time.
3. The device could also be used for overvoltage protection if little changes are made in the circuit for the protection of any device connected to it.

## REFERENCES

- [1] *An Overview of Integratable Current Sensor Technologies, Proc, 38<sup>th</sup> LAS, Annual Meeting, Oct. 2003, pp 1231-1258.*
- [2] *Bob Mammano A Paper on Current Sensing Solutions for Power Supply Designers.*
- [3] *Don Alfano, Evaluating AC Current Sensor Options for Delivering System, Silicon Laboratory Inc, Austin TX.*
- [4] *Electronic Components and Technology, Sangwine S. (Van Nostrand Reinhold)*
- [5] *Energy Scavenging Power Sources for Household Electrical Monitoring, Proc. Power MEMS 2006 Berkely.*
- [6] *GLOBAL SPEC, Current Sensor Information on GlobalSpec.*
- [7] *Linear Technology, Current Sense Circuit Collection, [www.linear.com/ad/current\\_sense.jsp](http://www.linear.com/ad/current_sense.jsp)*
- [8] *NAM Desa, literature on current sensor, 2007.*
- [9] *Patrick A. Cattermoh, The Fundamentals of Current Sense Transformer Design.*
- [10] *Richard Dickinson & Shaun Milano, Isolated Open Loop Current Sensing Using Hall Effect Technology in an Optimized Magnetic Circuit*

[11] Ron Mancini, *Sensor to ADC-Analog Interface Design*, *Analog Application Journal*, TI

[12] *Using Current Monitor for Load Analysis*. Kele Technical Reference,  
<http://www.kele.com/Tech/Monitor/Power/TRefPM6.html>.

