

**DESIGN AND CONSTRUCTION
OF AN AUTOMATIC ROOM
HEATER**

BY

EZEKIEL AZE VINCENT

2005/22027EE

**A THESIS SUBMITTED TO THE DEPARTMENT OF
ELECTRICAL AND COMPUTER ENGINEERING,
FEDERAL UNIVERSITY OF TECHNOLOGY MINNA,
NIGER STATE.**

**IN PARTIAL FULFILLMENT OF THE
REQUIREMENT FOR THE AWARD OF BACHELOR
IN ENGINEERING (B.ENG) ELECTRICAL AND
COMPUTER ENGINEERING DEPARTMENT.**

November, 2010.

Declaration

I Ezekiel Aze Vincent declare that this work was wholly and solely conducted by me under the supervision of Engr. A. G. Raji, Department of Electrical and Computer Engineering, Federal University of Technology, Minna. I also hereby relinquish the copyright to the Federal University of Technology, Minna.

Ezekiel Aze Vincent
(Student Name)



09/11/2010
Signature and date

Engr. A.G Raji
(Project supervisor)

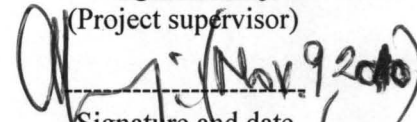

(Nov 9, 2010)
Signature and date

Engr. A.G Raji
(Head Of Department)

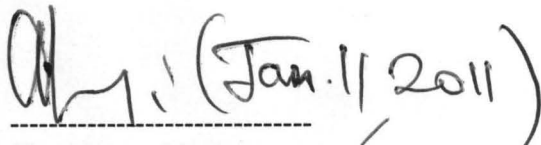

(Jan. 11, 2011)
Signature and Date



(External Supervisor)

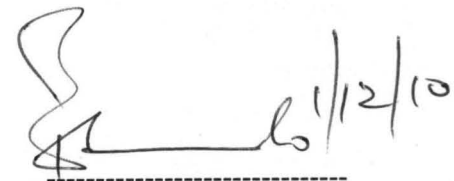

11/12/10
Signature and Date

Dedication

This report is dedicated to the highest God. Who alone doeth great wonder and for his Grace, Love, Mercies and Protection throughout my period of studying at Federal University of Technology Minna Niger State.

Acknowledgement

I give thanks to almighty God who is the giver of life and the sustenance of destiny for keeping me through this work and my stay in the University. Also my unreserved thanks to my supervisor Engr. A.G Raji for his tireless effort and unlimited sacrifice of his private time, whose constructive criticism brought out the full potential in me toward the actualization of a meaningful project like this. May God bless you sir. A million thank to other lecturers in the department, who at one time or the other imparted knowledge in me.

My special regard to my sister Mrs. Chinyere Ugwu for her responsibility as a sister and a mother as well by ensuring that my studies were successful. Also to my daddy Mr Ezekiel Christopher who as always wished me well. I say, may God reward him in abundance. Amen.

My unreserved gratitude to my dear in-laws Mr. Peter Ugwu and Mr. Uchenna Madu who gave me all the financial and moral support ensuring that my academic success is actualized. I pray that God will bless them abundantly.

I cannot forget to appreciate the effort of my mummy, brother and sisters; Mrs. Fedilia Christopher, Anthony, Justina, Christian, Lilus (late) Felicia (late) Marthins (cousin. I pray for God's blessing upon their lives.

Also, my regard to Mr. Bature who made life easier for me. I am not forgetting my friends Titus Joshua (potential Rev.), Charles Madu (potential Rev.), Shedrack Abudul (potential Engr.) and finally Jimmy Gere (potential Engr.), thank God we made it to the end.

Abstract

Very cold weather causes deadly diseases during the rainy season such as pneumonia. This is a major problem that requires a multi-dimensional solution. In this project, a partial solution is proposed by way of construction and installation of an automatic room heater to facilitate regulation of room temperature during the cold (rainy or harmattan) season. Results obtained from a prototype demonstrated satisfactory room temperature regulation.

TABLE OF CONTENTS

Page Title page.....	i
Declaration.....	ii
Dedication	iii
Acknowledgement.....	iv
Abstract.....	v
Table of content.....	vi-viii
List of figures.....	ix
 CHAPTER ONE	
1.1 Introduction.....	1
1.2 Aims and Objective.....	2-3
1.3 Methodology.....	3
1.4 Precaution.....	4
1.4 Scope.....	4
 CHAPTER TWO	
2.1 Literature Review.....	5
2.2 Historical Background.....	5

2.4	Motivation.....	7
-----	-----------------	---

CHAPTER THREE

3.0	Design analysis and Implementation.....	8
3.1	Power supply Module and Calculation.....	9
3.1.1	Transformer Stage.....	9
3.1.2	Rectification Stage.....	10-11
3.1.3	Smoothing and Filtering.....	12-13
3.1.4	Voltage Regulator.....	13
3.1.4.1	LM78XX series.....	14
3.1.4.2	LM79xx series.....	14
3.1.5	Calculation.....	15-18
3.2	The Sensing Circuit.....	18-19
3.3	Specification of LM324 OP-AMP.....	19
3.4	Switching Module.....	20-23

CHAPTER FOUR

4.1	Operation and Testing.....	24-25
-----	----------------------------	-------

CHAPTER FOUR

4.1	Operation and Testing.....	24-25
4.1.1	Mode of Operation.....	24-25
4.1.2	Testing.....	25
4.2	Result.....	25
4.3	Limitation.....	26

CHAPTER FIVE

5.1	Conclusion and Recommendation.....	27
5.1	Conclusion.....	27
5.2	Recommendation.....	27
5.3	References.....	28

List of figures

- Fig. 3.0 Block diagram of an automatic room heating system.
- Fig. 3.1 Block diagram of regulated power supply unit.
- Fig. 3.2 (a) A transformer circuit symbol.
- Fig. 3.2 (b) Graphical representation of output voltage from the transformer.
- Fig. 3.3 Schematic diagram of rectifier circuit.
- Fig. 3.4 Wave form from the output of the rectifier.
- Fig. 3.5 Wave form at the output of voltage regulator.
- Fig. 3.6 Wave form of regulated voltage output.
- Fig. 3.7 A complete power supply module.
- Fig. 3.8 Schematic diagram of sensing circuit.
- Fig. 3.9 Switching module.
- Fig. 4.0 A complete circuit diagram of an automatic room controlled heating system

CHAPTER ONE

1.1 Introduction

Recent advances in circuit designs have led to the production of systems for control of room heater. Apart from aesthetic considerations, such system are very useful where power economy is of great interest. The heating element ranges from switching ON and OFF of the switch control circuit, to vary the temperature level produced by the heating element. Such control can be realized by means of programmed or intelligent circuit or manually operated switch from where the user turns the element ON and OFF as desired [1].

Automatic control system involves the use of programmed or intelligent circuit to switch the element as appropriate. A programmed control is one in which the user specifies the time for the element to come ON or change in intensity, or go OFF. In intelligent control, the system is capable of interacting with the environment to determine to switch ON or OFF the element or when to vary the temperature by control circuit [1].

The automatic room heater is used to raise the surrounding temperature of the building during the rainy or harmattan season. Such a system serves a variety of purposes, ranging from pneumonia prevention and many others. Heating element is expected to be ON whenever the temperature of the room falls below the expected temperature and OFF whenever the temperature of the room rises above the expected temperature in the rainy or harmattan season [1].

1.2 Aims and objectives

The major purpose of this project work is to design and construct an automatic controlled room heating systems. This project will therefore focus on the design of the DC operated switch. This forms the heat system of the heat controlled element {1}.

In various homes, industries, most of the heating control is done manually. This mode of control does not guarantee efficiency. There is tendency of either forgetting to switch OFF this element immediately after dawn, or even for the rest of the day, thereby causing a reduced lifespan of the room heater. This project work would therefore provide a feasible solution to this problem. The system would be designed such that the switching would be as accurate as possible. In as much the system has to be capable of responding fast to the changes in the temperature level of the environment, it should not respond to sudden rise in temperature, the system should switch OFF when such happens and switch OFF delay time should be as minimal as possible (a few seconds). When the room temperature falls below normal temperature, the switch is expected to respond fast enough. The response should be such that the least acceptable heating level and switch on should be a few microseconds [1].

Heating control systems help to make commercial building more comfortable, productive and energy efficient. These controls can turn the element OFF.

Moreover, energy savings realized by the use of this device is quite enormous. Walking during the day, one would always observe that most households neglect the energy consumption or energy wastage contributed by room heater which is switched ON all through the hours of the day. The design will provide power economy [1].

The use of this switching device would also reduce manual labor. Some things, the user of such room heater may desire to OFF the device, but out of forgetfulness or laziness, may leave the element ON, burning out hard earned energy and might burn the whole building causing damage to the user itself. Since the switching is automatic, it saves the user the stress walking up to the switches and toggling it twice each day at cold or hot weather.

1.3 Methodology

When the input of the system control is connected to a 240V AC supply at a frequency of 50Hz, an alternating current is fed into the input of the transformer and 15V AC supply is obtained at the output of the step down transformer. The step down voltage is rectified by diodes D_1 , D_2 , D_3 and D_4 and filtered by capacitor C_1 for complete DC voltage signal (12v). A regulator LM7812 is used to ensure that not more than 12v DC voltage is produced at the output of the regulator, and finally ripples are removed by capacitor C_2 which at the end serves as 12V DC supply to temperature sensor LM35 and the out of the sensor is connected to the non-inverting side of the comparator of LM324 IC and the output of the comparator is connected to the inverting operational amplifier while the output is connected to the base of the switch transistor. When a positive voltage is obtained at the output of the comparator, it switches on the transistor which in turn activates the relay that powers the element. When a negative voltage is obtained at the output of the comparator, it switches OFF the transistor which in turn de-activates the relay and the heating element automatically goes OFF [2].

1.4 **Scope**

Although this project is primarily concerned with heat change, many of the principles, technology and approaches discussed are of basic importance and they find application in most heating systems.

This project examines the simple transducer heat control which is useful for control of heat for basic home appliances such as microwave oven, water heater and room heater.

CHAPTER TWO

2.1 Literature review

During the olden days, people kept their body warm by setting up fire woods or by wearing of so much thick jackets just to protect their body against known diseases called pneumonia. Heating by sun light or artificial heating as opposed to the natural heating of the sun light, was probably first furnished by campfire and by torches made of wood. [2].

2.2 Historical Background

The earliest heating system came from fire wood. Men discovered that wood dipped into animal fat lasted longer and gave a stronger heat. Wood heating systems were in use for several years.

Candles were not meant for only visual purposes but also for heating purposes. The first candle was stalk filled with beeswax from beehives [4]. The ancient Egyptians had wickless candles made of lumps of tallow rapped with rags to keep from melting apart when they burned. The Romans used candles made with wicks. Candles are made in decorative styles and colors. Some in glass containers are used for religious purposes. These are three or four inches in diameter and burns for hours. Some candles are as tall as ten feet and last for years.

2.2 Present day electric heater

The electricity produced by rubbing objects against fur was known to the ancient Greeks, Phoenicians, Parthian and Mesopotamians. Some proposed that Parthian and Mesopotamians may have had some knowledge of electroplating based on the discovery of the Baghdad battery, which resembles a galvanic cell. In 1600 [5], the English scientist William Gilbert first used the new word “electrics”, which means Amber in Greek word. Later, this gave rise to English word “electric” and “electricity”, in sir Thomas Brownian’s pseupodia Epidemical of 1646. in 18th century [5], Benjamin Franklin conducted extensive research in electricity. He had theories on the relationship between heating and static electricity, including his famous kite-flying experiment, which was a key attached to a wet string and kite. During a lightning storm a spark struck his finger showing that lightning was electricity. His work provided the basis for electrical technology. Other scientist included Luigi Galvani (1737-1798) Alessandro Volta (1745-1827), Michael Faraday (1791-1861), Andre-Marie Ampere (1775-1836) and Georg Simon Ohm (1789-1854). With the discoveries from these scientists, electric lighting has been developed in so many ways that it plays a part in nearly every activity of man. The study and practice of electric lighting has become a profession by itself.

With the above mentioned heating services, lives are protected due to technology advancement. Automatic room heating system, taking the advantage of the recent development in electricity, is designed and constructed to ease human stress in switching operation.

2.3 Motivation

The energy savings realized by the use of automatic room heating system is quite enormous. Walking in the room during the rainy or harmatan season, one would observe that most heating elements such as 200W electric bulb at homes are left ON all through the day and night. This increases power wastage in the country. But this project will take care of this shortcoming and save useful energy.

Secondly, the use of this switching system would reduce manual labour. At times the user of such room heater may desire to put them OFF but out of laziness or forgetfulness, could leave the heating element ON. Since the switching is automatic, it saves the user stress, walking up to the switches and toggling it twice each time he wants them ON or OFF.

CHAPTER THREE

3.0 Design analysis and implementation

This chapter describes the module used in the design of the automatic room heating system using sensor. The theoretical background of each module is explained in subsequent pages. Below is the block diagram of automatic room heating system.

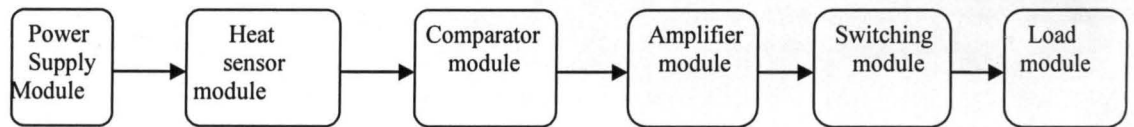

Fig.3.0: Block diagram of automatic room heating system.

The power system module is the power house of the entire circuit. The temperature sensor from the heat sensor module senses the temperature and sends a signal to a comparator. The comparator compares the output from the sensor with a predetermined level. Its output tells if the temperature level indicates low or high. The logic unit decides what the signal from the comparator implies and, thus enables the next block in the diagram to operate.

A delay is required to ensure that the signal is not instantaneous and thus indicates a valid transition from hot to cold weather or vice versa. If within the delay time, the logic unit confirms that the signal is valid indication of such transition then the switching module is driven through the comparator module. Hence, the load at the output is energized.

3.1 Power supply module

The power supply module is an electronic circuit that provides direct current (DC) voltages and current from AC sources, usually from the mains supply of the electricity distribution company like PHCN in Nigeria. The output is used to operate the automatic heating system.

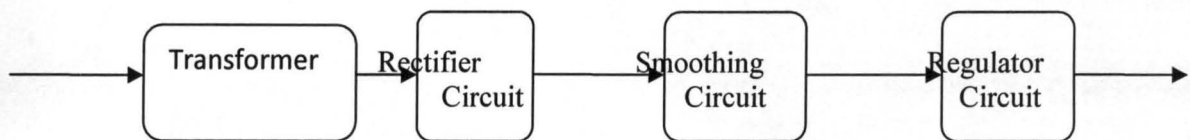

Fig.3.1: Block diagram of a regulated power supply unit

3.1.1 Transformer stage

A step down transformer is used to reduce 240V AC from Power Holding Company of Nigeria (PHCN) to 15V AC. This output voltage is now fed into the rectifier circuit to produce the required 12V DC by the automatic heating system.

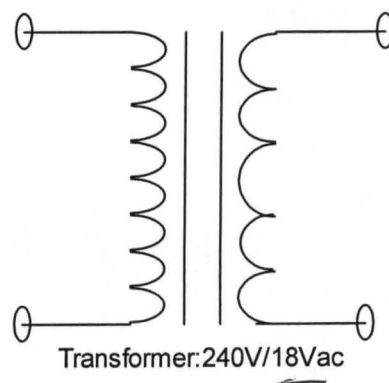

Fig. 3.2: (a) A transformer circuit symbol

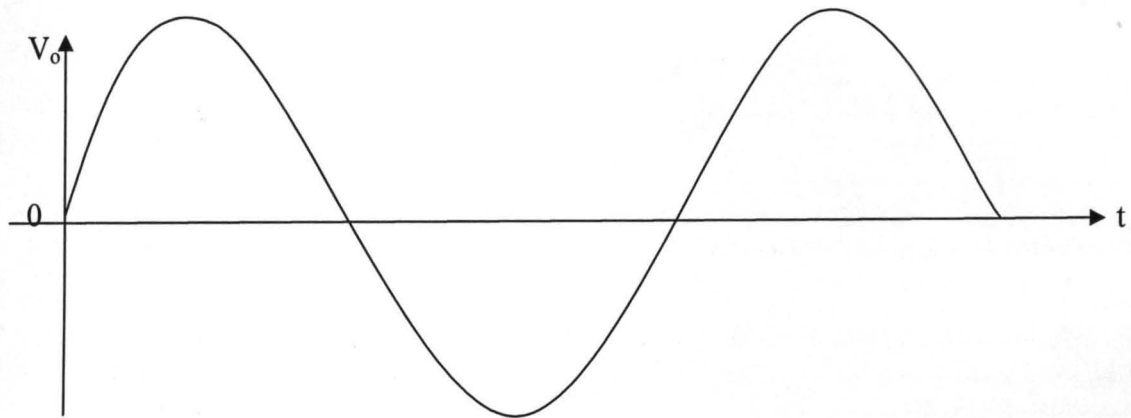

Fig.3.2: (b) Graphical representation of output voltage from the transformer

3.1.2 Rectification stage

Most of the electronic devices and circuits require a DC source for their operation. The most convenient and economical source of power is the domestic AC supply, it is advantageous to convert this alternating voltage (usually $240V_{r.ms}$) to the direct voltage (usually smaller in value). This process of converting AC voltage into DC voltage is called rectification and it is accomplished with one diode (half wave rectification) or four diodes (full wave rectification)

- i. Rectifier
- ii. Filter and
- iii. Voltage regulator circuit

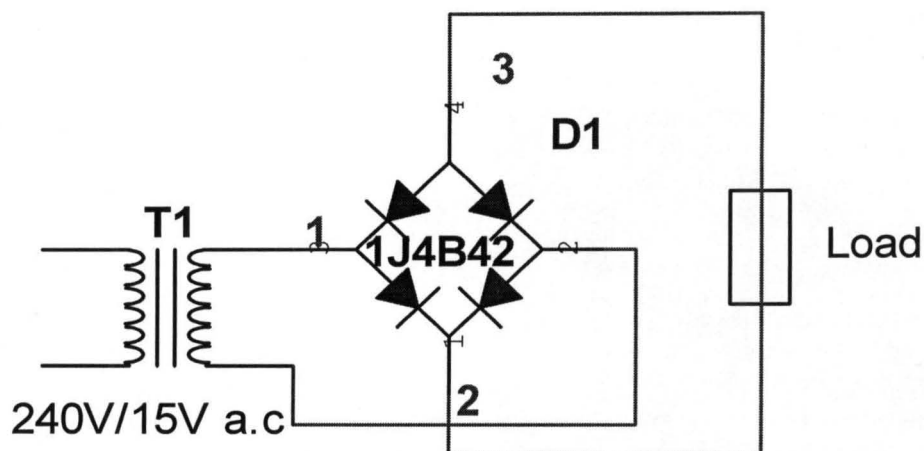

Fig. 3.3 Schematic diagram of rectifier circuit

This project adapted the use of a full wave bridge rectifier because of its ability to produce the approximate varying and reference voltage. The bridge rectifier is similar to a full wave because it produces a full wave output voltage.

During positive half cycle of the a.c supply terminal 5 of the secondary transformer is positive and terminal 8 of the supply output of the secondary transformer is negative as shown in figure 3.3 above. Diodes D_1 and D_3 becomes forward biased (ON) whereas diodes D_2 and D_4 are reversed biased (OFF), hence current flow along the path 5,7,6 and 8 thereby charging the capacitor $C1$ and to maintain value V_{sm} .

While during the negative half cycle of the a.c voltage, secondary terminal 8 of the transformer becomes positive and 5 negative, Diodes D_2 and D_4 are then forward biased (ON) and diodes D_1 and D_3 are reversed biased (OFF), hence current flow along this path 8,6,7 and 5, charging capacitor $C1$ to maximum d.c voltage V_{sm} , current flow in the form through the circuit in both half cycle of a.c input supply thereby supplying a constant dc voltage to the voltage regulator and the compensating capacitor $C2$ [6].

3.1.3 Smoothing and filtering

There is need for the use of filter since the output voltage from the rectifier circuit is a pulsating DC voltage. Capacitor filter is used to produce a complete DC output voltage equal to the peak value of the rectifier voltage. This type of filter is the most widely used in the power supply. Below also shows the filter output voltage DC signal.

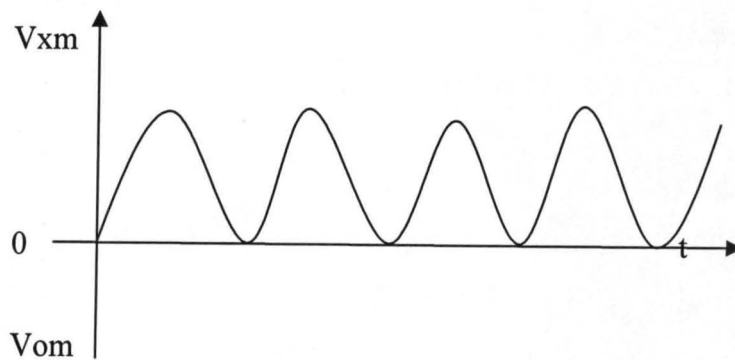

Fig 3.4 wave form from the output of the rectifier

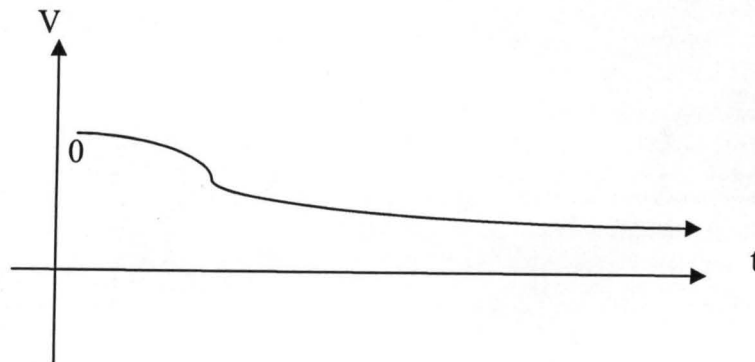

Figure 3.5 Wave form at the output of voltage regulator

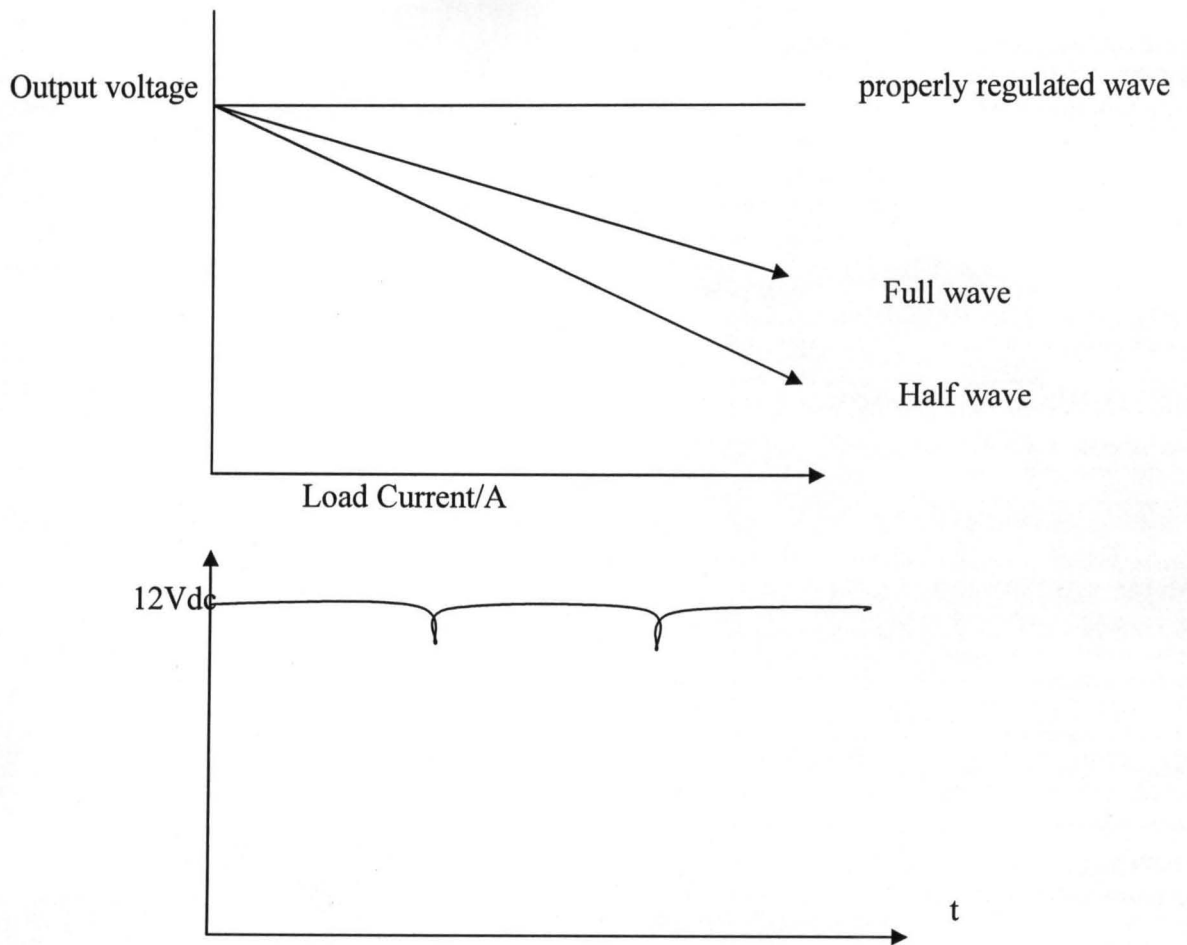

Fig 3.6 wave forms of regulated voltage output

3.1.4 Voltage regulator (ic)

Most IC regulators have one of these types of output voltage,. Fixed positive, fixed negative, or adjustable. IC regulators with fixed positive or negative output factory-trimmed to get different fixed voltage with magnitude from above 5V to 24V. in this project the IC regulator that are used are those in the LM78XX series

3.1.4.1 The LM78xx series

The LM 78XX series (where XX is either 05,06,08 10,12, 18 Or 24) is typical of the three terminal voltage regulators the LM7805 produce an output of +5v, the LM7806 produce +6v and so on. Here, LM7809 is used to produce a voltage of +9v.

3.1.4.2 The LM79xx series

The LM 79XX series is a group of negative voltage regulators with present voltage of -5,-6,-8,-10,-12,-15,-18 or -27v for instance and LM7905 produces a regulated output voltage of -5v. But this project used a single positive supply. Below is a typical power supply module.

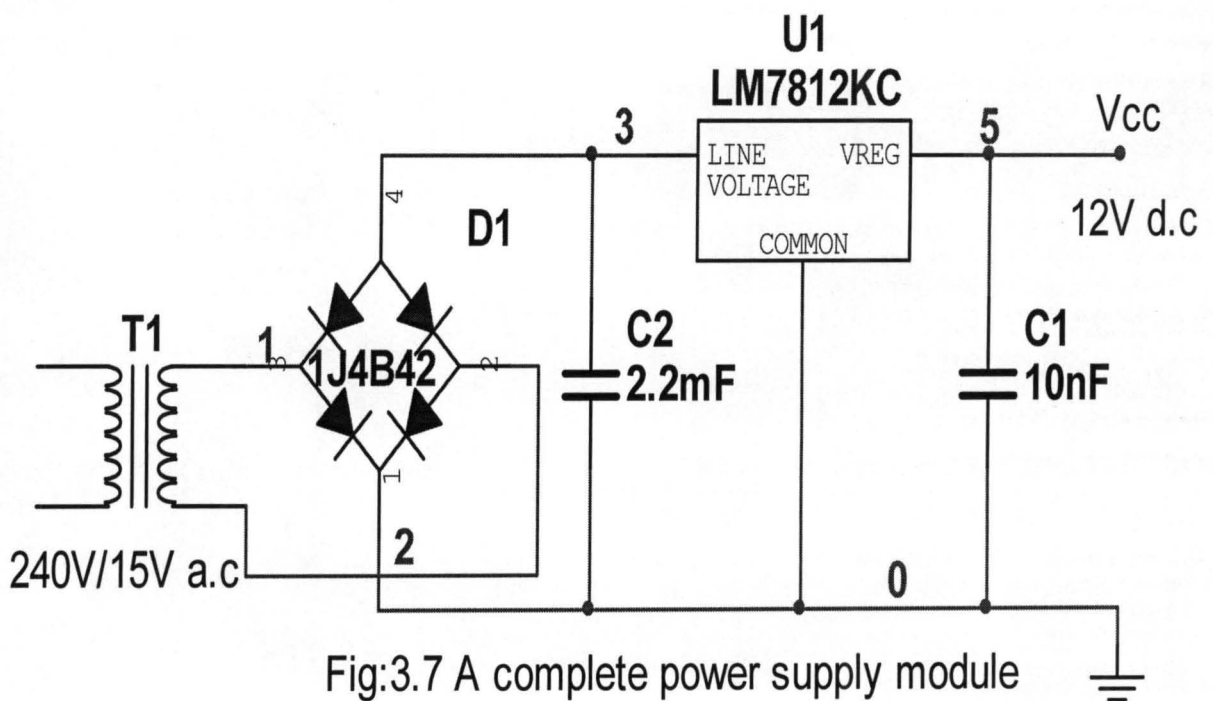

Fig:3.7 A complete power supply module

3.1.5 Calculation

Design Specification for power supply unit

Input voltage = 220v a.c mains

Supply voltage = 15v d.c

Maximum Current = 1.00A

Using the formula below to find the capacitance of the filter capacitor.

$$I/C = dv/dt \dots\dots\dots i$$

Where I = peak output current

C = Capacitance

dv = ripple voltage

dt = change in time of ripple

Normally ripple factor for full wave rectifier = 0.482 but in this project work rectification here, assuming ripple factor of 15%

Vrms = root mean square voltage

Vp = peak voltage

For Vrms = 15V

$$V_{rms} = V_p/\sqrt{2} \dots\dots\dots ii$$

$$15V = V_p/\sqrt{2}$$

$$V_p = 15V \times \sqrt{2} = 15 \times 1.44$$

$$V_p = 21.6V$$

$$\text{Also, } dv = 15\% \times V_p = 15/100 \times 21.6 \dots\dots\dots iii$$

$$dv = 3.24V$$

For frequency $f = 50\text{Hz}$

$$T = 1/f = 1/50 = 0.02s \dots\dots\dots iv$$

$$\text{For } dt = 1/2 \times 1/50 = 1/100$$

$$dt = 0.01s = 10\text{msec}$$

For Current, $I = 1A$

$$I/C = dv/dt$$

$$C = Idt/dv$$

Getting the parameters therefore the capacitance, C of the capacitor used can be found here.

$$C = (1 \times 10 \times 10^{-3})/3.24v$$

$$C = 0.0012592593$$

$$C = 1259 \times 10^{-6}f$$

C – 1259 μ f

But this is not a standard value, therefore a close value of 2200 μ f with voltage rating of 35V was chosen, and the compensating capacitor is 0.01 μ f.

The LED is a light emitting diode which is used as power indicator and R_1 is its current limiting resistor. This is needed because the maximum current rating of the LED is 45mA as specified by the manufacturer.

It was design that 8mA flows through the LED, if the voltage drop across the LED is 1.2V then from the formula

$$R_1 = \frac{(V_s - V_d)}{I} \dots \dots \dots \text{v}$$

Where R_1 = current limiting resistor

V_s = supply voltage = 12volt d.c

V_d = voltage drop across LED = 1.2V

I = current through LED = 8mA

Therefore, $R_1 = \frac{(12 - 1.2)}{(8 \times 10^{-3})}$

$$R_1 = 1350\Omega \dots \dots \dots \text{vi}$$

This resistance value is not a standard value, so a value of 2000 Ω (close value) was chosen. LM7812: this is a 12volt positive voltage regulator IC is used in this project. It is capable of output current of 1 Ampere. This is suitable since T_1 is just supplying 0.707A which is less than IC's maximum rating.

For proper operation of IC, its unregulated input voltage should be at least three times greater than its rated output, for this reason, a 240V/15V a.c, and 500mA step-down transformer was used.

3.2 Sensing circuit

The sensing circuit consists of the operational amplifier, the comparator module and the voltage divider modules. Resistors from the voltage divider holding the reference voltage at half the output voltage of the comparator. Its values are chosen to be 56k Ω , 1.6k Ω and 10k Ω respectively for this project.

The operational amplifier in this case is LM324 which comprises four (4) operational amplifiers. One of the operational amplifiers is used to generate a high differential gain of the output voltage of the temperature sensing element LM35 in question.

The comparator module is LM324 operational amplifier configured as a voltage comparator; it compares the magnitude of the two input signals between the inverting and the non-inverting input. Its output is high as soon as the voltage at the non-inverting terminal (pin 6) is slightly greater than the voltage at the inverting terminal (pin 3) which holds the reference voltage.

The variable resistor (VR_1) forms another voltage divider which determines the voltage at pin 6 depending on the calibration range. Variable resistors VR_1 and VR_2 were chosen with a value of 10k Ω .

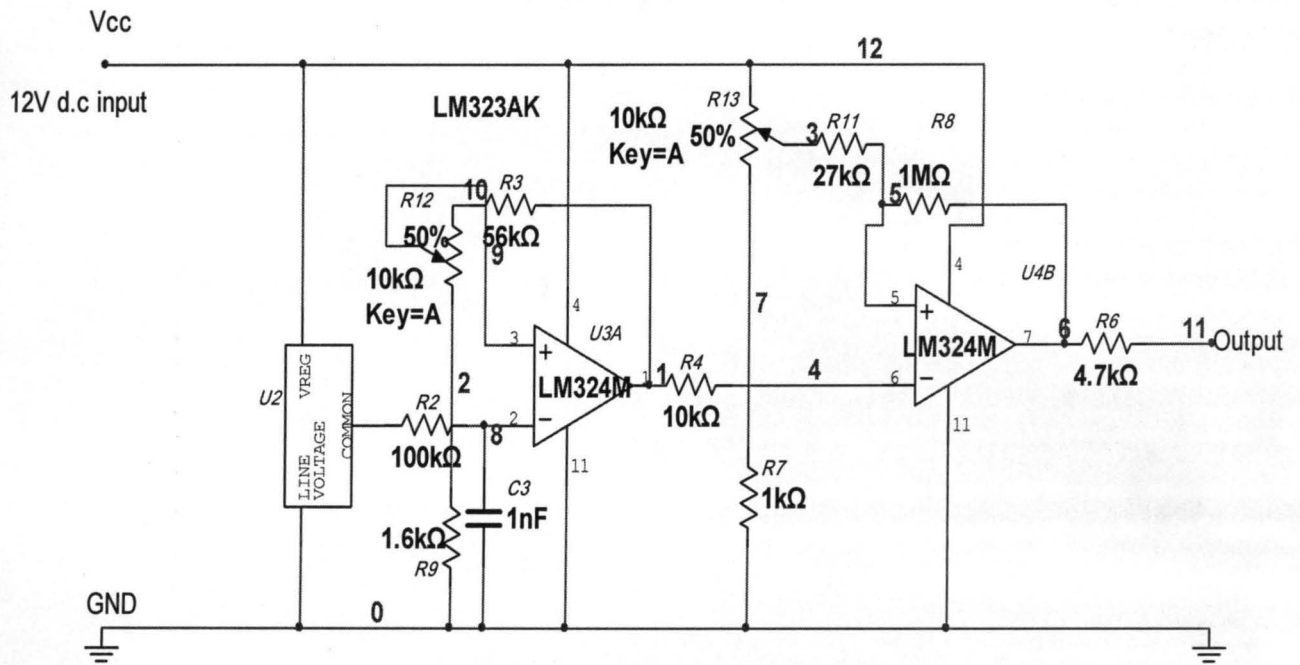

Fig: 3.8 Schematic diagram of a sensing circuit

3.3 Specification of lm324 operational amplifier

Supply voltage = ± 4.5 to ± 18 V maximum.

Differential input voltage = ± 30 V.

Input voltage = ± 15 V.

Safe operating temperature = 0°C to 70°C .

Storage temperature = -65°C to 150°C .

Maximum power dissipation = 500mW.

3.4 Switching module

Switching means turning ON and OFF directing an electric current, or redirecting an electric current. The switching module interfaces the entire system with the load. Without this module, the aim of this project will not be activated.

For this project, a transistor and relay were used for the switching module. The choice of the transistor was based on its reliability, responsiveness, durability and its snap action. Thus, with the aid of the transistor switch, a relay can be turned ON and OFF by small signals in the cut off region (open) whereas the transistor operates in the saturation region and creates a short circuit.

NPN high speed switching transistor (C945) silicon type was used and was connected in common emitter configuration with its collector output connected to the relay coil. The small signal from the logic unit (comparator module) will produce a higher switched output required to drive the relay coil, this in turn energizes the load at the socket outlet. Below is shown the switching circuit.

➤ Relay

A solid state relay is a mechanical switch used to switch other circuit On and Off. It enables small current in one circuit to control a much larger current in another circuit or the simultaneous switching of more than one circuit also the contacts are of two basic types Normally Open (NO), and Normally Closed (NC). In addition they can be single pole (SP) single throw or double pole (DP) double throw.

It can also be said that relay is an electromagnetic device or a solid state device operated by varying the input which in turn is used to control other devices connected to its output. They form the simplest form of automatic switch in an electronic circuit. Relays consist basically of 2 parts;

- (i) The coil
- (ii) The magnetic switch.

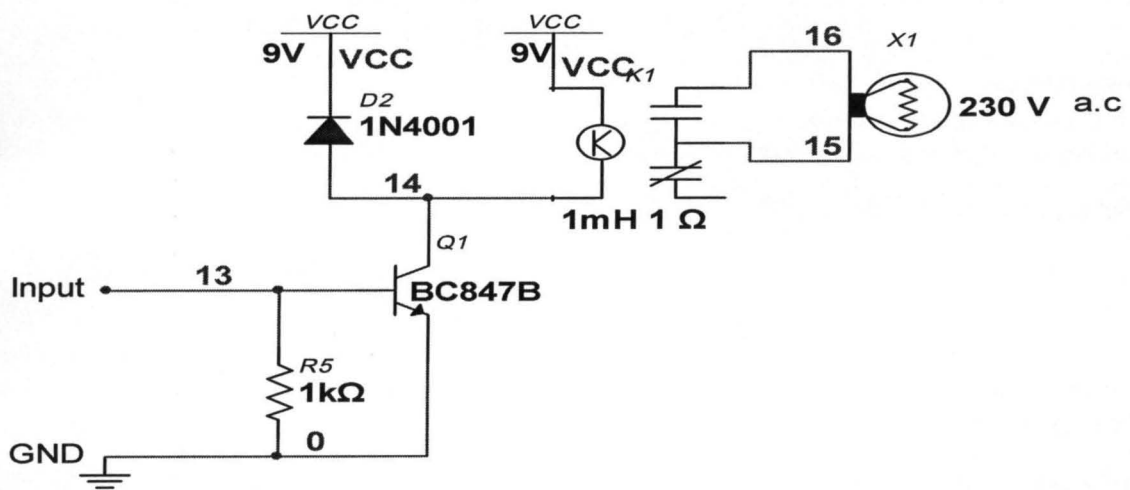

Fig: 3.9 Switching module

Choice of transistor

NPN = Silicon general purpose

$$V_{CBO} = 75V$$

$$V_{CEO} = 40V$$

$$V_{BE} = 0.6V$$

$$I_C = 0.6A$$

$$H_{fe} = 200$$

$$\text{Power} = 0.5\text{W}$$

$$\text{Frequency} = 300\text{MHz}$$

The load resistance is 240Ω (R_c) which is the resistance of the relay coil. To operate a transistor as a switch it has to be driven into saturation.

$$I_{c(\text{sat})} = V_{cc}/R_c = 12/240 \dots\dots\dots \text{vii}$$

$$= 50 \times 10^{-3} \text{A}$$

$$\text{For } \beta = 200$$

$$I_c = I_b = I_c/\beta = (50 \times 10^{-3}/200) = 25 \times 10^{-5} \text{A} \dots\dots\dots \text{viii}$$

$$\text{Therefore, } R_b \text{ base resistor} = (V_{cc} - V_{be}/I_b) = R_b \dots\dots\dots \text{ix}$$

$$R_b = (12 - 0.6/25 \times 10^{-5}) = 45.6 \text{k}\Omega \dots\dots\dots \text{x}$$

This value was halved so as to over drive the transistor by twice the required current to guarantee saturation and to take care of β tolerance.

$$\text{So that } R_b = 45600/2 = 22.8 \text{k}\Omega \dots\dots\dots \text{x1}$$

D_6 is a free wheeling diode to prevent damage to the transistor due to back electromotive force (Emf) from the relay coil. 1N4001 was chosen with peak inverse voltage (PIV) of 100V.

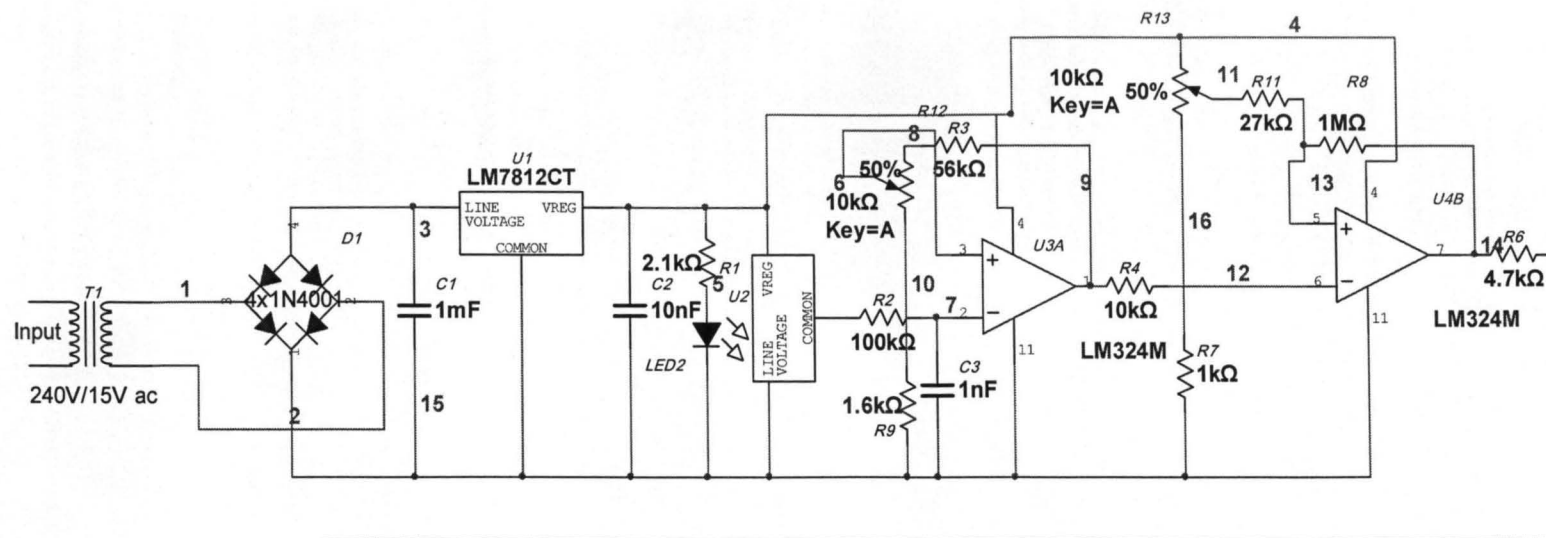

1B4B42
LM323AK

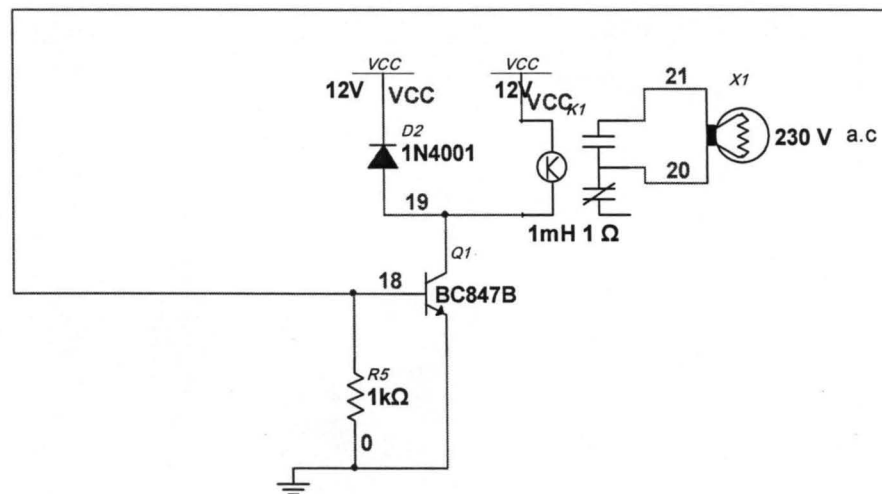

Figure: 4.0 A COMPLETE CIRCUIT DIAGRAM OF AN AUTOMATIC ROOM CONTROLLED HEATING SYSTEM

CHAPTER FOUR

4.1.1 Mode of operation

This project used an “all or nothing” approach. Circuit which react to temperature must include some adjustment as each person may want it to a different level of temperature. Thus, the circuit is a little bit complicated and includes a variable resistor (preset) [to allow user control.

The circuit is as shown in fig 3.8, resistor R_4 and R_5 so that the resistance cannot be below $10k\Omega$. This protects comparator from excessive current. Consider VR_1 and R_4 and R_5 as a single resistor connected in series to the comparator. The output will be divided between the single resistor and the comparator. If the variable resistor value falls, then the comparator voltage will simultaneously fall.

C945 NPN transistor will not switch ON until the voltage at its base rises to about 0.6V. Thus, if the resistance of VR_2 is low compare to VR_1 , R_4 and R_5 , less than 0.6V will be available at the transistor base and the transistor will not switch ON.

If the temperature of the sensor falls, its resistance will increase and the voltage at the transistor base will rise. As it reaches 0.6V, the transistor will turn ON.

The resistances, R_6 has little effect on the voltage at the transistor base as the current flowing is very small. The purpose of R_6 is to limit the current to a safe level, thus, protecting the transistor even if VR_1 is turn zero. Resistor R_4 and R_5 provide enough protection as its high value is chosen to be much higher than that of the sensor at low temperature.

The heater can be turned OFF by increase in temperature of the sensor. After all these have been put in place, the element now switches OFF at high temperature.

4.1.2 Testing

After the construction of the automatic room heating system, it was then tested to ensure performance. The sensor (LM35) was inserted in a cold container and the temperature was adjusted to a preset level until the output voltage from the operational amplifier was amplified. The comparator, compared the amplified voltage and sent a biasing current of 0.1mA to the base of the transistor which in turn energized the relay to close its contact, immediately, the element was ON.

Conversely, when the cold container was removed, the sensor sensed increase in the temperature of the environment up to a certain level such as 28⁰, which de-energized the relay thereby opening its contact which switched OFF the element. This testing was carried out several times to ensure reliability. This confirmed that the device was reliable and the aim of the project was actualized.

4.2 Result

Table of value

Temperature (degree)	Transistor status
24	Saturated (ON)
25	Saturated (ON)
26	Saturated (ON)
27	Saturated (ON)
28	Cut off (OFF)
29	Cut off (OFF)

Table of value

Temperature (degree)	Transistor status
24	Saturated (ON)
25	Saturated (ON)
26	Saturated (ON)
27	Saturated (ON)
28	Cut off (OFF)
29	Cut off (OFF)

4.3 Limitations

- ✓ Due to the poor accuracy/repeatability, of the temperature sensor, the temperature at times overshoots the maximum temperature at which the system is supposed to turn off.
- ✓ The system makes use of analogue circuits which increases the likelihood of error due to ripples in the analogue signal.
- ✓ In the course of the project, setbacks and construction encountered were mainly due to unavailability of required components, non-workable circuit design and ignorance of knowledge of electrical circuit principle.

4.4 Precaution

- i. The Vero board for the circuit construction was cleaned to remove dust.
- ii. The rating of the regulator IC, diodes and capacitor were ascertained and then soldered.
- iii. The color codes for the resistors were carefully decoded to ascertain their values after which they were soldered to the board.

CHAPTER FIVE

5.0 Conclusion and Recommendation

5.1 Conclusion

There are many design methods in the world today for producing automatic room heating systems. These methods vary according to the intended use. But the method adopted for this project work makes for simplicity, reliability and portability.

5.2 Recommendation

Sophisticated signal processing techniques in order to have a digital readout based system is recommended to bring this work toward limelight of better temperature monitoring in many applications.

References

- [1] H.C. Baeyer Van (1998). "Warmth Disperses and Frime passes". the history of heat new York
- [2] R. Siegel and Hohn R. Hwell. Thermal Daditun Heat Transfer Second Edition Page 4.
- [3] Nelkon and Parker. Advance Level Physics 7th Edition Page 628.
- [4] WWW. commlinx.com.
- [5] Len Jones. Basic electronics For Tomorrow's world Page 191,79,228.
- [6] B.L and A.K. Theraja Electrical Technology, S. Chand and Company Ltd Page 1922,1988
- [7] R.L Tokhem Theory and problems of Digital Principle Page 37,35,54
- [8] Paul Horowitz and W. Hill. The Art of Electronics, Cambridge University Press Page 47,48
- [9] [http// library.thinkquest.org/20031/history](http://library.thinkquest.org/20031/history).
- [10] a.us/instruct/calderwoodD/diglogic/not.htm