

**DESIGN AND CONSTRUCTION OF A
MICROCONTROLLER BASED TEMPERATURE
CONTROLLED FAN REGULATOR
(WITH A SEVEN SEGMENT DISPLAY)**

BY:

GODWIN OSASOJE ILALOKHOIN

2005/22036EE

**A THESIS SUBMITTED TO THE DEPARTMENT OF
ELECTICAL AND COMPUTER ENGINEERING,
FEDERAL UNIVERSITY OF TECHNOLOGY.**

MINNA.

NOVEMBER, 2010

TABLE OF CONTENTS

TITLE PAGE

TABLE OF CONTENT

DEDICATION

DECLARATION

ACKNOWLEDGEMENT

ABSTRACT

CHAPTER ONE: GENERAL INTRODUCTION

1.0 INTRODUCTION

1.1 AIMS AND OBJECTIVES

1.2 METHODOLOGY

1.3 LIMITATIONS

CHAPTER TWO: LITERATURE REVIEW

2.1 THEORETICAL BACKGROUND

2.2 BLOCK DIAGRAM OF DESIGN

2.2.1 TEMPERATURE SENSING UNIT

2.2.2 DISPLAY UNIT

2.1.3 SPEED REGULATING UNIT

2.1.4 THE CONTROL UNIT

CHAPTER THREE: DESIGN AND CONSTRUCTION

3.1 CIRCUIT DESIGN ANALYSIS

3.2 CIRCUIT DIAGRAM

3.2 FLOW CHART OF THE MICROCONTROLLER MACHINE CODE

CHAPTER FOUR: TESTING AND DISCUSSION OF RESULT

4.1 CIRCUIT CONSTRUCTION

4.2 CASING CONSTRUCTION

4.3 TESTING

4.4 RESULT DISCUSSION

4.5 BILL OF ENGINEERING MATERIALS

CHAPTER FIVE: CONCLUSION AND RECOMMENDATION

5.1 CONCLUSION

5.2 RECOMMENDATION

REFERENCES

APPENDIX

DECLARATION

I Godwin Osasoje Ilalokhoin declare that the project work was done by me and has never been presented anywhere for the award of a degree. I also hereby relinquish the copyright to federal University of technology.

Godwin Osasoje Ilalokhoin

(Name of Student)

..... *Gg* 4/11/2010

(Signature and date)

Engr. Mrs. Caroline Alenoghena

(Name of Supervisor)

..... *Caroline* 4/11/10

(Signature and date)

Engr. A. G. Raji

(Name of H. O. D.)

..... *A.G. Raji* (Jan. 11, 2011)

(Signature and Date)

..... *Engr. A. G. T. Ghab*

(Name of External Examiner)

..... *Engr. A. G. T. Ghab* 1/12/10

(Signature and Date)

DEDICATION

I dedicate this project to God who gave me knowledge, understanding, protection and divine direction throughout my years of study at the university. I also dedicate this project to the blessed memory of my late father, Mr. Felix Ilalokhoin. Without his help over the years I would not have made it this far.

ACKNOWLEDGEMENT

My special thanks and appreciation goes to Almighty God for His divine protection and provision over me during my stay in School. My appreciation also goes to my parents who have been of some great help to me in my upbringing.

My profound gratitude goes to the Head of Department, Engr. A. G. Raji, my project supervisor Engr. Mrs. Caroline Alenoghena and the entire members of staff at the the electrical and computer engineering department. Also my gratitude goes to the members of my family, my mother, Mrs. Shomi Ilalokhoin and my siblings Victor Ilalokhoin and Patience Ilalokhoin and my inspirational cousin Monday Imooje. My friends Grace Olomiwe, Jackson Okeri, Jude Atugbokoh and all those who were around me all the time.

Finally, my appreciation goes to all well wishers whose collaborative effort and assistance made this project a success.

ABSTRACT

The project design is the design and construction of a microcontroller based temperature controlled fan regulator with a seven segment display. The principle of operation is based on feedback mechanism, in which the output (speed of the fan) changes with change in input (temperature). A microcontroller was used to do the logical operations of the circuit. It triggers the appropriate relay at a given temperature and tells the seven segment display what figure to display per time. A negative temperature coefficient thermistor which works at a range of 33°C to 41°C was used as a transducer in the circuit. The device is a prototype and as such a 12 volt DC fan is used. The circuit was designed, constructed, tested and found to be in good condition. It provides convenience for the user as it removes the need to manually control the speed of the fan as it handles the control automatically based on changes in temperature.

CHAPTER ONE

1.0 INTRODUCTION

The microcontroller based temperature controlled fan is an automated system that uses a microcontroller to control the regulation of temperature changes in a room using changing speeds of a DC fan. The basic mechanism of the device is a feedback system in which output changes in relation to change in input.

Feedback control is the basic way by which systems, whether mechanical, electrical or biological, maintain their temperature equilibrium or homeostasis [1]. In higher life forms a drastic change in body temperature can have a harmful effect on the body of the live form. Thus, the need for regulation of temperature is very important.

With improvements in technology and changing societal taste, embedded systems (devices containing microcontroller/microprocessors) have become a major part of our lives. This is mainly because they make life easier for us, as they help in automating many devices we use in our day to day lives.

The microcontroller based fan is simply an improvement on the conventional manually controlled fan. It senses change in temperature in the room and switches on the fan and further increases the speed of the fan as the temperature in the room increases. This eliminates the need for manually switching on the fan and changing the speed of the fan, which can be an inconvenience, especially to disabled people.

An alarm is also incorporated into the system to sound when the temperature of the room is beyond that which can be regulated by the device. This is important, as it tells the individual using the device that the temperature in the room is too high and could be harmful to his health.

A further cooling device, such as an air condition unit, may be incorporated into the system in the future to regulate temperature when it is beyond that which the fan can regulate. More than one thermistor could be used to sense temperature changes at different points in the room.

1.1 AIM AND OBJECTIVES

The aim of the project is to demonstrate the application of electronics in temperature regulation and control. It tries to provide convenience to the user by providing an automated system that eliminates the need to manually change the speed of the fan as temperature in the room changes.

1.2 SCOPE OF WORK

The device is designed to sense temperature between the range of 33°C and 41°C. The fan has three (3) independent states or speeds used to regulate temperatures. It uses a microcontroller to make decisions on the control of the circuit. A buzzer is attached to the circuit to sound when the temperature range is well beyond that which the device can regulate.

1.3 METHODOLOGY

The work is achieved by using a negative temperature coefficient (ntc) thermistor (input temperature sensor) in parallel with a 47Ω resistor, connected to the control unit (89s51 microcontroller). As the temperature increase the input voltage also increases.

Four variable resistors are used and are fixed at different voltage levels (1.9V, 2.1V, 2.3V, 2.5V).

When the voltage drop from the input reaches these set values, current flows through the relative variable resistor and sends a low signal to the microcontroller. The microcontroller then responds to the input signal based on the written program that has been written to its memory. It triggers one or more of the three 6 v relays connected to it in relation to the change in input voltage, in order to change the speed of the fan.

As the speed changes the corresponding number is displayed on the seven (7) segment display. The display shows the change in speed from 0 to 3 and back.

1.4 LIMITATIONS

- The device is limited to three (3) speeds only.
- The use of a single temperature sensor may not sense the temperature at different points in the room.
- The design is also limited to the control of a single fan.

CHAPTER TWO

2.0 LITERATURE REVIEW

Temperature can be simply defined as the degree of hotness or coldness of a body [2]. Temperature plays an important role in determining the rate and extent to which chemical reactions occur. Temperature can be measured in several ways that center on a same concept; that temperature causes clear changes on matter.

From my review of past works I discovered that similar works had been done before. One of which was the design and construction of a microcontroller based temperature monitoring device with automatic cut out by Imevbore A. C. Abiodun (2003/15382EE). The work was achieved using an LM35 precision temperature sensor as the input unit. The sensor was interfaced with an Analogue to Digital Converter (ADC). Signals from the ADC were then transferred to the AT80C59 microcontroller, which switches off the relays connected to it when conditions are met. The relay switches off and on any device connected to it.

The circuit was basically a relay triggered cut-off to prevent damage to appliances and does not regulate temperature. Another limitation was that the design was not water proof so it cannot be used in wet areas. Some of the recommendations made were for a reduction in circuit space; using a microcontroller that incorporates the circuitry of an ADC and for an alarm unit with audible sound be incorporated into the system also.

The other project I came across was the design and construction of an automatic temperature controlled fan regulator by Amana Matthew (2003/15323EE). The work also made use of a LM35 temperature sensor, an ADC0804 Analogue to Digital Converter, 8 different integrated circuits (40103B, 4081B, 4069B, 4511B, 4017B, 4060B, 40174B,

4518B), and LED display and two 7 segment displays. The circuit basically senses changes in temperature and increases the temperature in accordance with temperature change. Its major limitation was the complexity of the circuit, which makes it difficult to reproduce economically in large quantities. The recommendations were a more compact circuitry and an alarm to signal very high temperature change.

My work basically is an improvement on these works as it builds upon their recommendations. Less circuitry is used as an Analogue to Digital Converter is not used, there is no LED display and only one 7 segment display is used. An audible audio alarm is also incorporated into the system. Since it uses fewer components it is also more economically viable than the previous works.

2.1 THEORETICAL BACKGROUND

Temperature is one of the most frequently measured environmental quantities in our world today. This is because it affects not only our bodies but a lot of things around us. Atmospheric temperature is very important to the human body. It plays a role in determining the rate and extent to which chemical reactions occur. This is why the body has its own internal structure to regulate its temperature, since temperatures only a few degrees higher than body temperature could result in harmful reactions with serious consequences [3]. This is why this project is of utmost importance to the society.

2.2 BLOCK DIAGRAM OF THE CIRCUIT

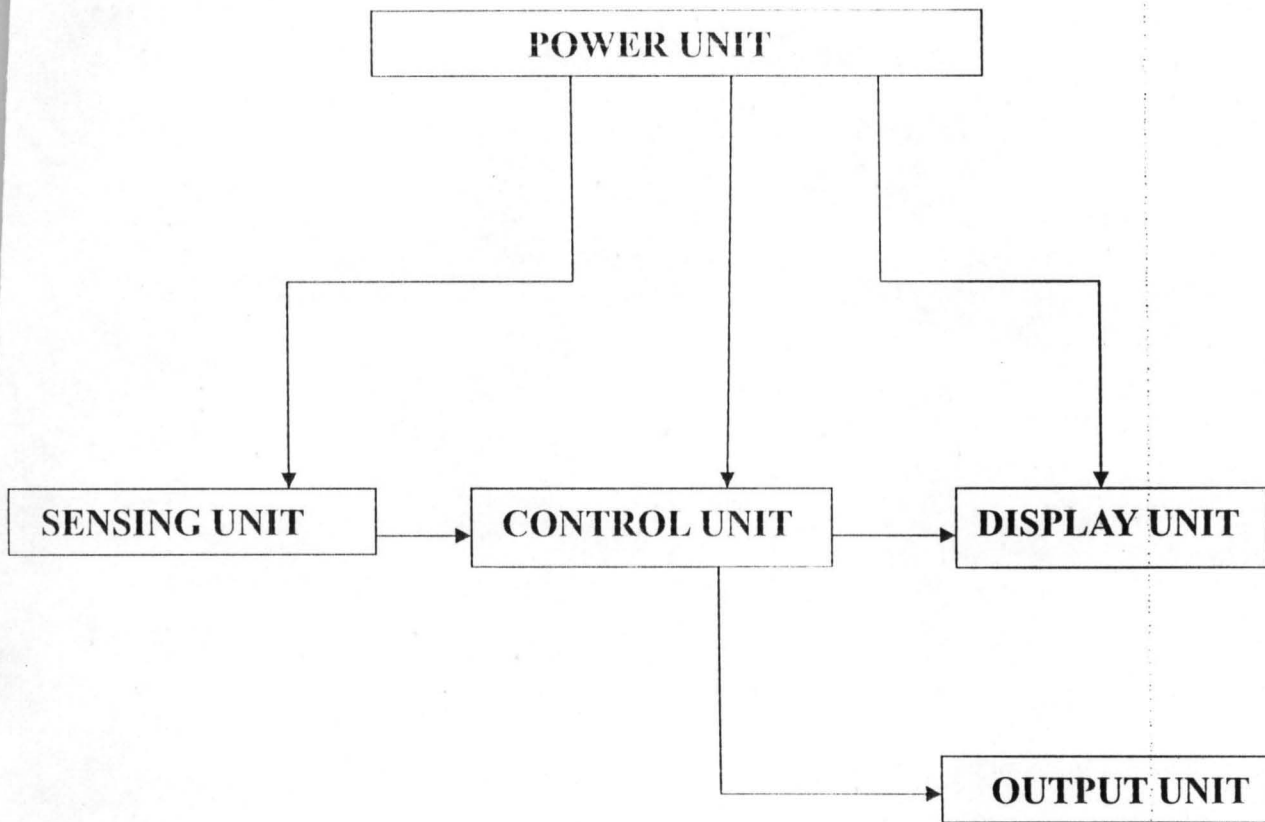

Fig. 1. Block diagram of the circuit

2.2.1 POWER UNIT

This is the source of electrical energy into the circuit. It consists of a step-down transformer, which is used to step down AC voltage from 230V to 12V. The resultant voltage is further passed through a 2200 μ F capacitor to filter out the ripples. An LED is used as an indicator to show when the circuit is turned on and goes off when the power supply is cut off. A 1K Ω resistor is used to reduce the voltage entering the LED.

Three voltage regulators are used to provide regulated 5, 9, and 12 voltages. These voltage levels are used for to control the speed of the fan, with increasing voltages resulting in faster speeds.

2.2.2 TEMPERATURE SENSING UNIT

This is the input unit of the circuit. It consists of a $1\text{K}\Omega$ thermistor connected in parallel with a 47Ω resistor. A thermistor is an electronic component that exhibits a large change in resistance with a change in its body temperature. The word "thermistor" is actually a contraction of the words "thermal resistor" [4]. They are ceramic semiconductors and have either large positive temperature coefficient of resistance (PTC devices) or large negative temperature coefficient of resistance (NTC devices).

A negative temperature coefficient (NTC) thermistor is used in the circuit. NTC thermistors are composed of metal oxides. The most commonly used oxides are those of manganese, nickel, cobalt, iron, copper and titanium. The fabrication of commercial NTC thermistors uses basic ceramic technology. In the basic process, a mixture of two or more metal oxide powders are combined with suitable binders, are formed to a desired geometry, dried, and sintered at an elevated temperature. By varying the types of oxides used, their relative proportions, the sintering atmosphere, and the sintering temperature, a wide range of resistivity and temperature coefficient characteristics can be obtained.

The range of temperature for the thermistor used in the circuit is between 33°C and 41°C , which is suitable for a small room. The 5V regulator supplies power to the sensing unit.

2.2.3 CONTROL UNIT

This unit is responsible for making the decisions that make the circuit work properly. Signals coming in from the sensing unit are interpreted using a microcontroller and the corresponding output is sent out to the chip. An Intel 89s51 microcontroller was used in the circuit. The Intel 89s51 is a variant of the common Intel 8051 microcontroller.

Microcontrollers are also known as dedicated or embedded controllers. These devices are used to control smart machines such as microwave ovens, clothes washers, sewing machines, e.t.c. Below is the internal structure of the microcontroller used.

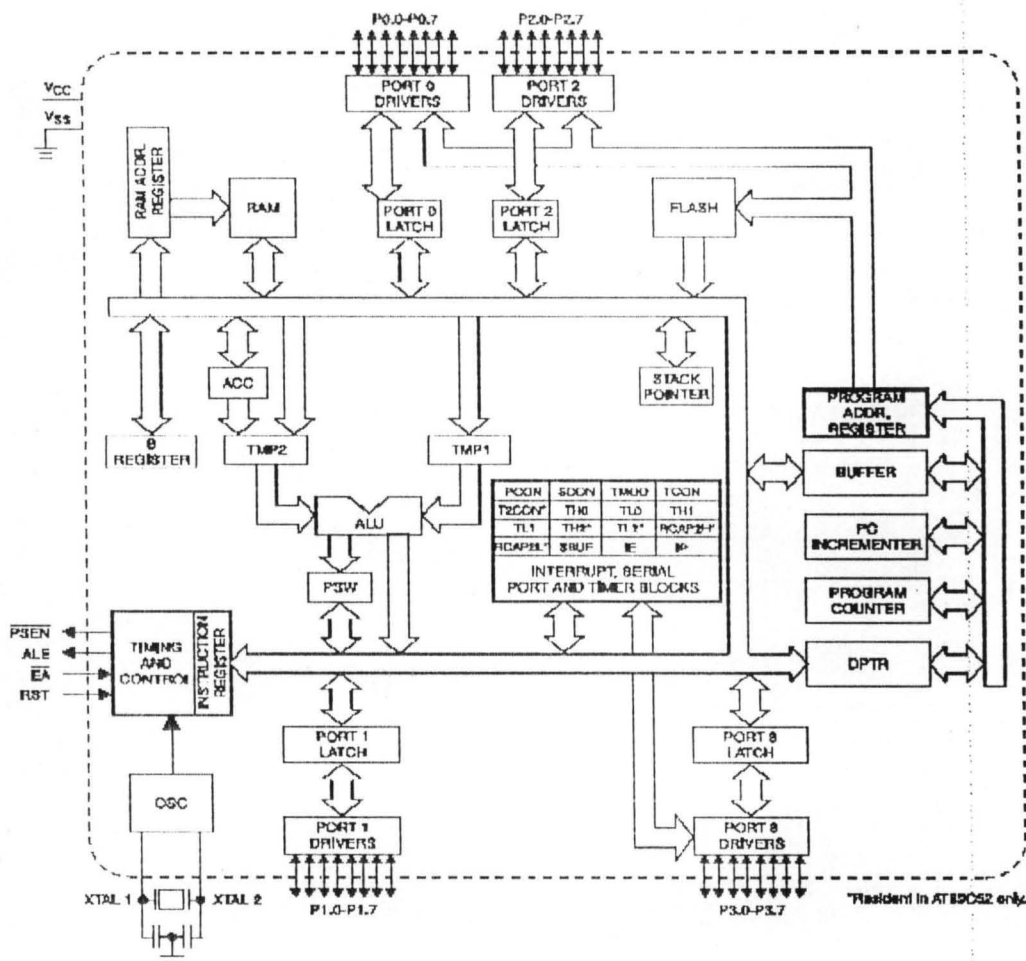

Fig. 2. Microcontroller internal architecture

The microcontroller is a 40 pin chip with four programmable ports. The pin configuration is given below.

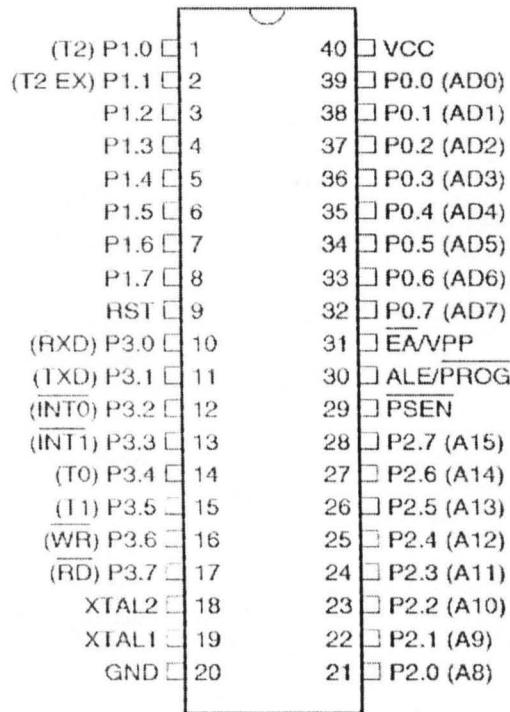

Fig. 3. Pin configuration of microcontroller

2.2.4 DISPLAY UNIT

One common requirement for many different digital devices is a visual numeric display. We are far more used to thinking and dealing with decimal numbers, hence the need for a display to show the state of our devices. There are different types of display in used in circuits today, which include the conventional Light Emitting Diodes (LEDs), Liquid Crystal Display (LCDs) and the seven (7) segment display. A seven (7) segment display was used in the project.

Seven (7) segment displays are simply an array of the minimum possible number of LEDs in such a way as to represent numbers in a simple fashion. This requires just seven

LEDs (plus an eighth one for the decimal point, if that is needed). A common technique is to use a shaped piece of translucent plastic to operate as a specialized optical fiber, to distribute the light from the LED evenly over a fixed bar shape. The seven bars are laid out as a squared-off figure "8". The result is known as a seven-segment LED.

Seven (7) segment displays are used in a wide range of applications such as clocks, watches, digital instruments, and many household appliances. The seven (7) segment display can be in either a common anode or common cathode configuration. A common anode seven (7) segment display was used for the project.

2.2.5 OUTPUT UNIT

This is the part of the circuit responsible for providing an output, which can be any of the three (3) speeds of the fan. The output unit is connected directly to the microcontroller (control unit) and works based on the program already written to the chip. The relay configuration form the most important part of the output unit. This configuration consists of a $1K\Omega$ resistor connected to an A1015 transistor, which is also connected to a 6v relay. The transistors trigger the relays connected to them when they receive signals from the microcontroller. A diode is connected to each relay to allow for a part for back emf.

Three sets of relays are used to trigger the three independent speeds of the fan. They are powered by 5V, 9V and 12V respectively. These voltages are gotten from the power unit.

CHAPTER THREE

3.1 CIRCUIT ANALYSIS

3.1.1 ANALYSIS OF THE POWER UNIT

This unit provides electrical power to the circuit. It gets its input from a 500mA, 12V step-down transformer, which provides constant AC power supply. The AC power is then converted to DC using a bridge rectifier. A 2200 μ F capacitor serves as a filter for the rectifier's output. This component removes the influence of the remaining AC component in the expected DC output. The voltage rating of the capacitor is 35V.

The 7805, 7809 and 7812 voltage regulators are incorporated into the circuit to provide regulated 5V, 9V and 12V respectively. The 5V regulator is the source of V_{cc} for the circuit and also provides power for one of the relays. The 9V and 12V regulators serve the other two relays. The different voltages are used to be able to get different speed from the DC fan.

A Light Emitting Diode (LED) is used to determine the presence of electric current in the circuit. A resistor is connected in series with the LED to limit voltage through the LED, otherwise it would burn out. The resistor value is given by:

$$R = (V_s - V_l) / I$$

V_s = supply voltage

V_l = LED voltage (about 2V)

I = LED current (about 3mA)

$$R = (5V - 2V) / (3mA)$$

$$= 1000\Omega$$

1k Ω resistor is used to protect the LED.

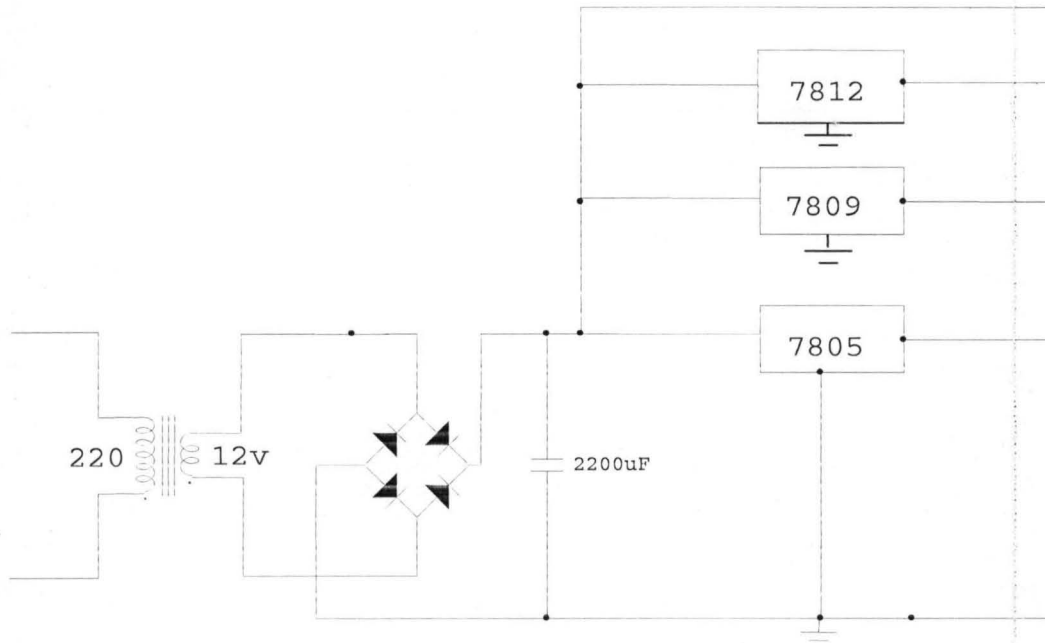
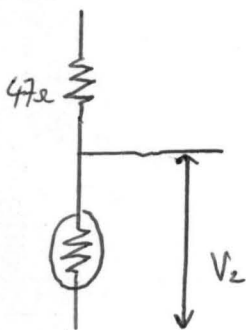

Fig. 4. Circuit arrangement of the Power unit

3.1.2 ANALYSIS OF SENSING UNIT

The sensing unit consist of a 47Ω resistance placed in parallel with a $1k\Omega$ negative temperature coefficient (ntc) thermistor. The ntc thermistor is a component that works on the principle that for every rise in temperature there is a corresponding decrease in resistance values.

To get the voltage entering the IN4001 diode, using voltage divider theorem



$$V_2 = \frac{1000}{1000 + 47} \times 5V$$

$$V_2 = \frac{1000}{1047} \times 5V = 4.7V$$

Fig. 5. Voltage across 47Ω resistor and thermistor

The diode has an voltage resistance of about 0.7V, therefore the voltage entering the set

of variable resistances is given as,

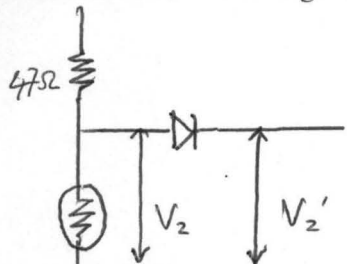

$$V_2' = 4.7 - 0.7 = 4V$$

Fig. 6. Voltage through the diode

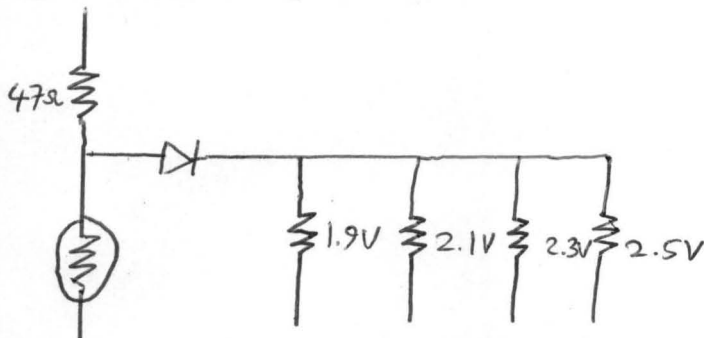

Fig. 7. The variable resistor arrangement

The thermistor goes from high to low at 1.7V.

For P1

$$1.9V \text{ ----- } 1000\Omega$$

$$1.7V = \frac{1.7 \times 1000}{1.9} = 895 \Omega$$

For P2

$$2.1V \text{ ----- } 1000\Omega$$

$$1.7V = \frac{1.7 \times 1000}{2.1} = 809.5\Omega \approx 810\Omega$$

For P3

$$2.3V \text{ ----- } 1000\Omega$$

$$1.7V = \frac{1.7 \times 1000}{2.3} = 739\Omega$$

For P4

$$2.5V \text{ ----- } 1000\Omega$$

$$1.7V = \frac{1.7 \times 1000}{2.5} = 680\Omega$$

Therefore, the resistance within the specified range is given by

$$R_T = R_{T_0} \times \exp [\beta ((T_0 - T) / TT_0)] \text{ ----- equation 1 [5]}$$

Where

R_T - resistance at temperature T (kelvin)

R_{T_0} - resistance at temperature T_0 (Kelvin)

β - material constant

T_0 - reference temperature

T - desired temperature

To get the value of the material constant, β

at 0°C , $R_T = 3400\Omega$ (resistance of thermistor in ice); 0°C is equal to 273K ($0 + 273$)

at 30°C , $R_{T_0} = 1000\Omega$; 30°C is equal to 303K ($30 + 273$)

$$\beta = TT_0 / (T_0 - T) \times \ln [R_T / R_{T_0}] \text{ ----- equation 2 [6]}$$

$$= \frac{273 \times 303}{303 - 273} \times \ln \frac{3400}{1000}$$

$$= 2,757.3 \times 1.2238$$

$$= 3,374.4$$

$$\approx 3,374$$

The temperature value for state 0 is,

From equation 1

$$\begin{aligned} T1 &= [1 / \beta \ln (R_T / R_{T_0}) + 1 / T_0]^{-1} \text{-----equation 3} \\ &= [1 / 3,374 \ln (895 / 1000) + 1 / 303]^{-1} \\ &= [(2.9638 \times 10^{-4} \times -0.1109) + 3.300 \times 10^{-3}]^{-1} \\ &= [(-3.2869 \times 10^{-5}) + 3.300 \times 10^{-3}]^{-1} \\ &= [3.267 \times 10^{-3}]^{-1} \\ &= 1 / (3.267 \times 10^{-3}) \\ &= 306.0912\text{K} \\ &\approx 306\text{K} \\ &= 306 - 273 = 33^\circ\text{c} \end{aligned}$$

For state 1 we have,

$$\begin{aligned} T2 &= [1 / 3,374 \ln (810 / 1000) + 1 / 303]^{-1} \\ &= [(2.9638 \times 10^{-4} \times -0.2107) + 3.300 \times 10^{-3}]^{-1} \\ &= [(-6.2447 \times 10^{-5}) + 3.300 \times 10^{-3}]^{-1} \\ &= [3.2376 \times 10^{-3}]^{-1} \\ &= 308.8708\text{K} \\ &= 308\text{K} \\ &= 308 - 273 = 35^\circ\text{c} \end{aligned}$$

For state 2 we have,

$$\begin{aligned}T_3 &= [1 / 3,374 \ln (739 / 1000) + 1 / 303]^{-1} \\&= [(2.9638 \times 10^{-4} \times -0.3025) + 3.300 \times 10^{-3}]^{-1} \\&= [(-8.9655 \times 10^{-5}) + 3.300 \times 10^{-3}]^{-1} \\&= [3.2103 \times 10^{-3}]^{-1} \\&= 311.4974\text{K} \\&\approx 311\text{K} \\&= 311 - 273 = 38^\circ\text{c}\end{aligned}$$

For state 3 we have,

$$\begin{aligned}T_4 &= [1 / 3,374 \ln (680 / 1000) + 1 / 303]^{-1} \\&= [(2.9638 \times 10^{-4} \times -0.3857) + 3.300 \times 10^{-3}]^{-1} \\&= [(-1.1431 \times 10^{-4}) + 3.300 \times 10^{-3}]^{-1} \\&= (3.1857 \times 10^{-3})^{-1} \\&= 313.9028\text{K} \\&\approx 314\text{K} \\&= 314 - 273 = 41^\circ\text{c}\end{aligned}$$

3.1.3 ANALYSIS OF CONTROL UNIT

The control unit is made up of an ATMEL 89s51 microcontroller, which is a 40 pin chip with 4 programmable ports. The chip was programmed using assembly language and written on the memory using a special purpose programmer. The microcontroller acts based on the inputs it receives and makes decisions on the corresponding output to trigger and the certain time to trigger the output. The logic table for the program is given below.

P1	P2	P3	P4	OUTPUTS.			
				5V RELAY	9V RELAY	12V RELAY	ALARM
1	1	1	1	1	1	1	1
0	1	1	1	0	1	1	1
0	0	1	1	0	0	1	1
0	0	0	1	0	0	0	1
0	0	0	0	0	0	0	0

N.B. Inactive high (1) and active low (0)

Table 1. Logic table for the microcontroller

For the first state when all inputs are high (that is inactive), all the outputs are also high. Non of the relays is triggered. The 7 segment displays 0. In the second state the first input P1 goes low, the microcontroller triggers the 5V relay and the 7 segment displays 1. For the third state, P1 and P2 goes low, both the 5V and 9V relays are triggered and the 7 segment displays 2. P1, P2 and P3 go low for the fourth state, the microcontroller triggers the 3 relays (5V, 9V and 12V) and the 3 is displayed. For the fifth and last state, all four inputs P1, P2, P3 and P4 go low and the microcontroller in turn triggers the 3 relays and the alarm, indicating that the temperature reached is beyond that which can be regulated by the circuit.

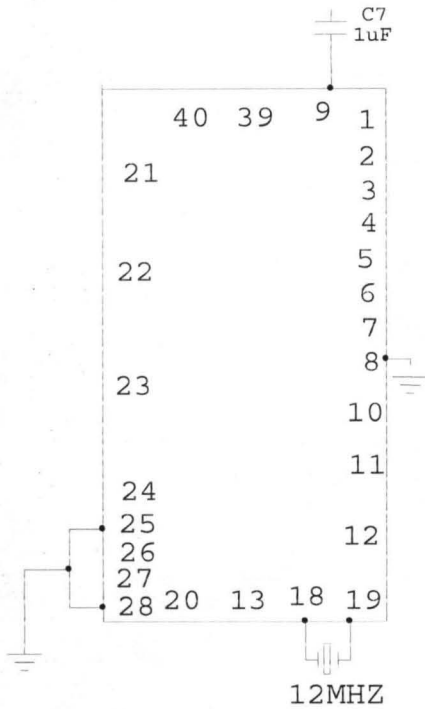

fig. 8. Microcontroller Pin arrangement

3.1.4 ANALYSIS OF THE DISPLAY UNIT

The display unit is a 7 segment display, which is an array of LEDs arranged to form numbers. The display shows the state of the DC fan at any given time. It acts based on the written code in the memory of the microcontroller and displays the corresponding number

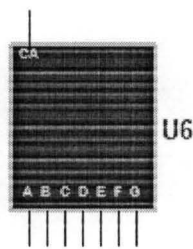

Fig. 9. Seven segment display

3.1.5 ANALYSIS OF THE OUTPUT UNIT

The output unit consist of the 3 relays and the DC fan. The relays control the speed of the fan, making it go fast or slower. The relays are controlled by the microcontroller and are powered by the 5V, 9V and 12V voltage regulators. An A1015 transistor was attach to each relay to help in triggering the relay. Protective diodes were connected to allow for the flow of back emf. The diodes are connected backwards so that they normally do not conduct. Conduction only occurs when the relays are off, at that moment current tries to continue to flow and is harmlessly diverted through the diodes.

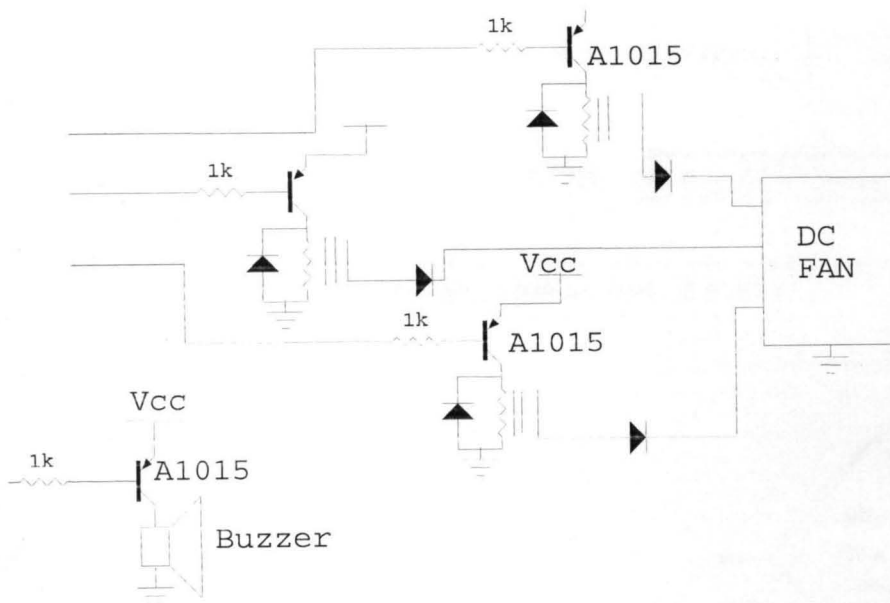

Fig. 10. Circuit arrangement for the output unit

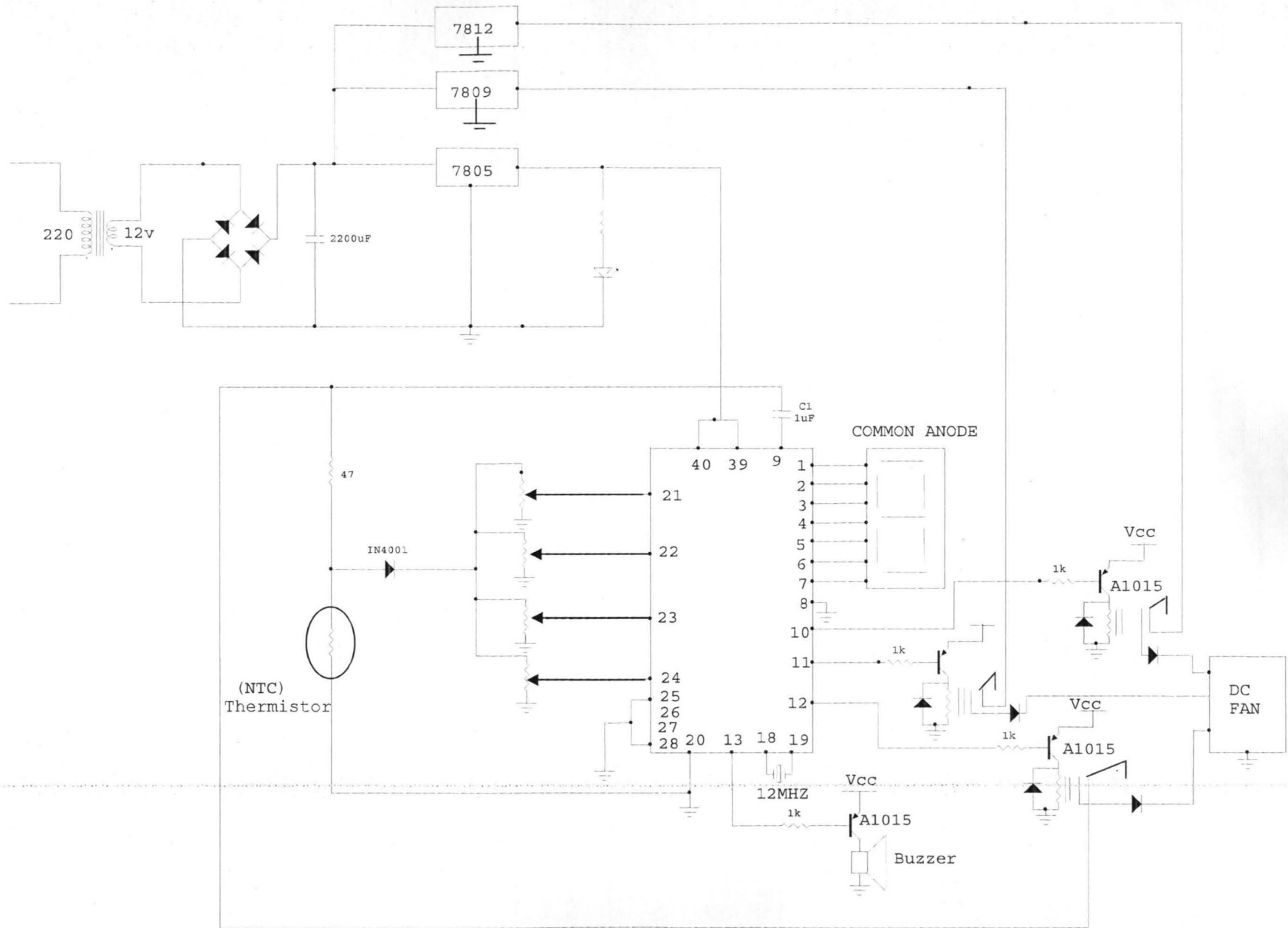

Fig 11. Complete circuit diagram

CHAPTER FOUR

4.0 CONSTRUCTION, TESTING AND DISCUSSION OF RESULT

4.1 CIRCUIT CONSTRUCTION

This part of the project involves practically converting the circuit diagram on the paper into a real working hardware. The first part entitled verifying that the circuit was working properly and this was done on a bread board. The work was tested in the laboratory and the circuit was seen to work properly.

The main construction was done on a vero board. The electronic components were carefully connected together using the circuit diagram. Each unit was executed one after the other, after which all the units were joined together as a single working construction.

The power supply unit was quite delicate during the construction, it was made with great care. After the complete construction the power unit was properly checked for short circuit and unwanted bridges.

The circuit construction involves the following materials and tools:

- * Soldering Iron
- * Soldering lead
- * Jumper wire
- * Microcontroller socket
- * Plier
- * Digital multimeter
- * Cutting Knife
- * Bread board
- * Vero board

4.2 CASING CONSTRUCTION

The casing of the device was made with transparent plastic material. The choice of the material was to allow the internal circuitry of the device to be easily visible and to allow for holes to be made for ventilation.

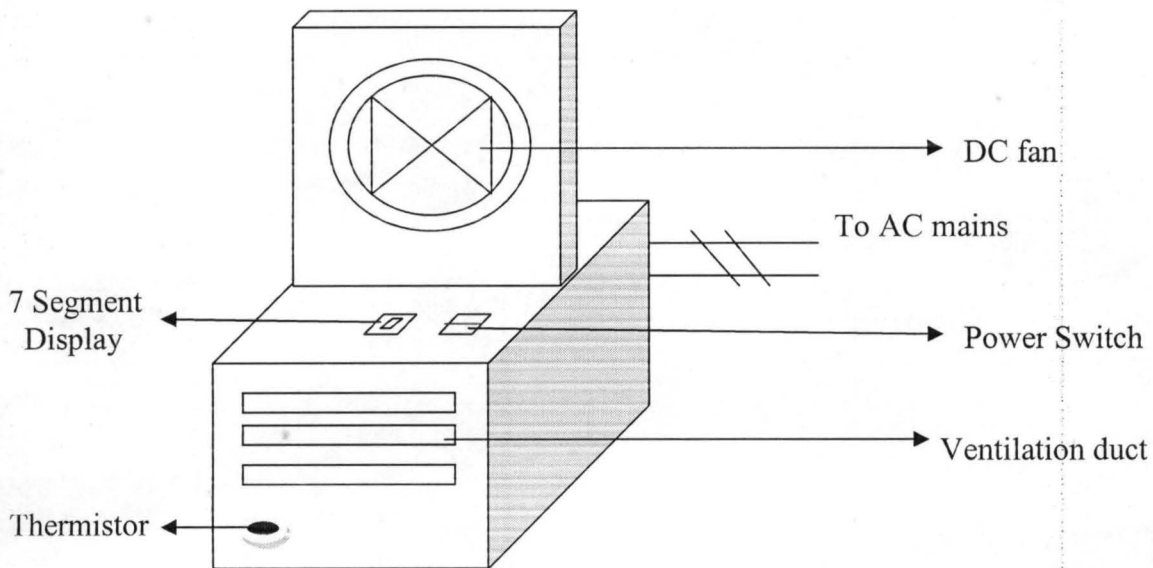

Fig. 12. The Casing showing external components

4.3 TESTING

TEST	OBSERVATION	REMARK
Device was plugged into AC power supply.	Light Emitting Diode (LED) came on.	Current is flowing in the power unit.
Warm Soldering Iron was placed near the thermistor and a temperature sensor	After a while the fan came on and a 1 was displayed on the seven segment display.	Fan came on at around 35°C.

connected to a multimeter was also placed near the thermistor .		
Heating was continued.	Speed of the fan increased and a 2 was displayed on the seven segment display.	Speed change was noticed at about 38°C.
Further heating was carried out.	Speed of the fan increased further and a 3 was displayed on the seven segment display.	Change was noticed at about 41°C.
Heating continued.	Alarm was triggered and an A was displayed on the seven segment display	Change was noticed at about 43°C
Soldering Iron was removed.	Speed of the fan gradually reduced and the display changed gradually from 3 to 2 to 1 and finally to 0.	Drop in temperature resulted in the reduction in the speed of the fan. The fan went off when temperature dropped to below 35°C.

Table 2. Table of tests and observations:

4.4 DISCUSSION OF RESULT

The result of the tests showed that the aim of the work was achieved. The temperatures at which the speed of the fan changes were also established. The temperature response were quite slow to remove the switching error of the involved relays. In reality the temperature of the environment increases and decreases slowly.

4.5 BILL OF ENGINEERING MATERIALS

S/N	ITEM	QUANTITY	UNIT COST(N)	TOTAL COST(N)
1	12v Transformer	1	200	200
2	Voltage rectifier chip	1	50	50
3	Capacitors: 1 μ F,16V	1	20	20
	2200 μ F, 35V	1	30	30
4	Light Emmiting diode	1	10	10
5	Voltage Regulators	3	50	150
6	Resistors: 1K Ω	5	10	50
	47 Ω	1	10	10
	Variable	4	20	80
7	Thermistor	1	100	100
8	Diode: IN4001	7	10	70
9	Relay	3	100	100
10	Buzzer	1	100	100
11	7 segment display	1	100	100
12	DC fan	1	250	250
13	ATMEL 89s51 Microcontroller	1	1000	1000
			TOTAL	2,320 NGN

CHAPTER FIVE

5.0 CONCLUSION AND RECOMMENDATIONS

5.1 CONCLUSION

The project successfully demonstrated the significance that the development in electronics can have in temperature control. The project shows that temperature in a room can easily be regulated without the operator having to manually change the speed of a fan. The automated system helps to provide convenience and is cost efficient as the bill of materials showed.

The circuit could easily be put into full scale commercial production at an economical cost.

5.2 RECOMMENDATIONS

- * An air conditioning circuit could be incorporated to regulate temperatures above which the fan cannot regulate.
- * The device could be designed to control multiple fans.
- * More than one thermistor could be used to sense temperature changes at different locations in the room.

REFERENCE

- [1] F. L. Lewis, (1992), *Applied Optimal Control and Estimations*, Prentice- Hall,
- [2] www.wikipedia.org/temperature.html (Oct. 2010)
- [3] Kittel, Charles, Kroemer, Herbert, (1980), *Thermal Physics, Second Edition*, W. H. Freeman and Company, New York, , pp 462
- [4] Center for Electronics design and Technology of India, (1999) *Basic Electric Components and Hardware*, CFS Documentation Cell, New Delhi India, pp 14
- [5] Bowthorpe Thermometrics, *Handbook on Thermistors*, PDF file, pp 9
- [6] Bowthorpe Thermometrics, *Handbook on Thermistors*, PDF file, pp 9

APPENDIX

COPY OF THE MICROCONTROLLER ASSEMBLY CODE

```
START:
MOV P1, #11000000B
MOV P2, #0FFH
MOV P0, #0FFH
CHECKING:
MOV A, P2
STATE1:
CJNE A, #11111111B, STATE2
MOV P1, #11000000B
MOV P0, #11111111B
SJMP CHECKING
STATE2:
CJNE A, #11111110B, STATE3
MOV P1, #11111001B
MOV P0, #11111110B
SJMP CHECKING
STATE3:
CJNE A, #11111100B, STATE4
MOV P1, #10100100B
MOV P0, #11111101B
SJMP CHECKING
STATE4:
CJNE A, #11111000B, ALARM
MOV P1, #10110000B
MOV P0, #11111011B
SJMP CHECKING
ALARM:
CJNE A, #11110000B, CHECKING
MOV P1, #10001000B
MOV P0, #11111011B
ACT:
CLR P0.3
LCALL DELAY
SETB P0.3
LCALL DELAY
JB P2.3, CHECKING
JMP ACT
DELAY:
DEDI:
MOV R7, #08
DED2:
MOV R6, #250
DED:
MOV R5, #250
DJNZ R5, $
DJNZ R6, DED
DJNZ R7, DED2
RET
END
```

