

DESIGN AND CONSTRUCTION OF A LIGHT SENSITIVE ALARM SYSTEM

BY

**ARE MUSIBAU TAIWO
2006/24370EE**

A THESIS SUBMITTED TO THE DEPARTMENT OF ELECTRICAL
AND COMPUTER ENGINEERING, FEDERAL UNIVERSITY OF
TECHNOLOGY,
MINNA.

NOVEMBER 2010.

DEDICATION

This final year project is dedicated to Almighty Allah, my father above, the creator of Heaven and Earth, the one who moulds and shapes the destinies of men. It is Him that deserves all the thanks and praise. Also to my parents, for the solid foundation they have given to me.

DECLARATION

I, ARE MUSIBAU TAIWO, declare that this work was done by me and has never been presented elsewhere for the award of a degree. I also hereby relinquish the copyright to the Federal University of Technology, Minna.

Are Musibau Taiwo

(Student)

.....

(Signature and Date)

Engr.A.G. Raji

(Head of Department)

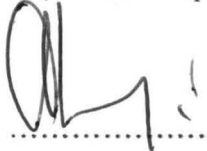
 (Jan-11, 2011)

(Signature and Date)

Mr. Usman N. Galadima

(Supervisor)

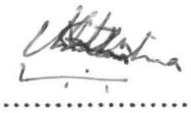
 05/4/2010

(Signature and Date)

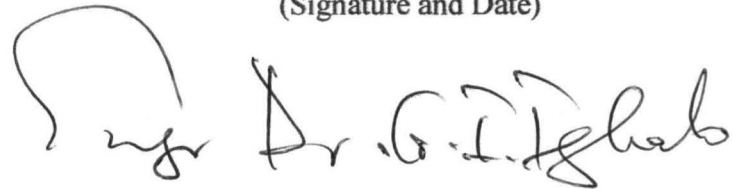

External Examiner

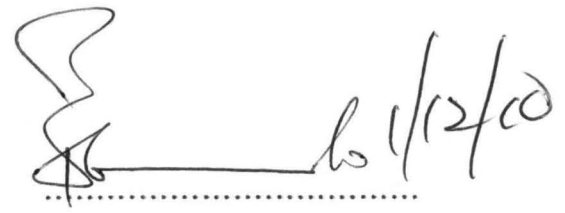
 1/12/10

(Signature and Date)

ACKNOWLEDGEMENT

First and foremost, I want to acknowledge Almighty Allah for his love and grace from the beginning of this academic journey to this point in time.

I wish to acknowledge the support, encouragement and advice given to me by my loving family. My parents; Im indepted to my late parents of blessed memory Alhaji and Mrs. Abdulsalam Are. My appreciation goes to my brother Mr Sikirullahi Are for his supports both financially and morally during my degree programme, my twin brother Mr. Kehinde Are, my brothers; Wale Are, Taiwo Are, Are Rahman and my lovely sisters; Bashirat, Latifat, Abimbola, Idowu, Kehinde Ares. I also appreciate Kola Hameed, Hon., Nurudeen Adebayo, Ilori Afolabi, Bello Ademola, Adeyemo Yusuff, Abdulsalam Isah, Sofiat Zakariyah, for their supports may Allah be with you all.

My sincere appreciation goes to my project supervisor, Mr. Usman N. Galadima. Meeting you has taken me step closer to my destiny. I thank you for your assistance, support and encouragement throughout the course of executing this project.

I wish to acknowledge all my group members who have worked persistently. Also to my friends who stood by me through the course of my project; Mustapha Sekoni, Fatola Sanya, Rufai Musiliudeen, Usman Lukman, Hajia Fatimah Mohd Katun, Kamardeen Raji, Eleja Rofiat.

I am grateful.

ABSTRACT

Protection of lives and properties are very importance to man. The design and construction of light sensitive is done to provide security using principle of light reflection and deflection between Laser diode and LDR sensor. The project is build around 555 Timer IC as a control system and confired in monostable mode. The device is powered by 12V DC and power indicator shows that the circuit is energized with battery as a back up if the supply from mains fails. The audible output signal is given by the buzzer and is being reset by the reset switch to make the output goes low.

TABLE OF CONTENTS

	Page
Title page	i
Dedication	ii
Declaration	iii
Acknowledgement	iv
Abstract	v
List of figures	vi
CHAPTER ONE:	
1.0 Introduction	1
1.1 Aims	4
1.2 Objectives	4
1.3 Methodology	4
1.4 Scope of work	6
1.5 Project outline	6
CHAPTER TWO: LITERATURE REVIEW	7
2.0 Theoretical background	7
2.1 Electronic components	8
2.1.1 Capacitor	8
2.1.2 Resistor	10
2.1.3 Diode	10

2.1.4 Laser diode	13
2.1.5 LDR	13
2.1.6 555 Timer	14
2.1.7 555 Astable	15
2.1.8 555 Monostable	16
2.1.9 555 Bistable	17
2.1.10 Relay	18
2.1.11 Transformer	19
2.1.12 9v Battery	20
2.1.13 Buzzer	20
CHAPTER THREE: DESIGN AND CONTRUCTION	21
3.1 power supply unit	21
3.1.1 Transformer specification	22
3.1.2 Rectifier	23
3.1.3 Filters	24
3.1.4 Voltage regulator	26
3.2 Sensor	27
3.3 Trigger circuit	28
CHAPTER FOUR: TESTS, RESULTS AND DISCUSSION	32
4.1 Testing and interfacing	32
4.1.0 Continuity testing	32
4.1.1 Performance testing	33
4.2 Result and Discussion	33

CHAPTER FIVE: CONCLUSION AND RECOMMENDATION	34
5.0 Conclusions	34
5.1 Recommendations	35
References	36

LIST OF FIGURES

Fig.1.1 Block Diagram.....	6
Fig.2.1a Capacitor Diagram.....	11
Fig.2.1b Capacitor Symbol.....	11
Fig.2.2 Resistor.....	12
Fig.2.3 Diodes.....	13
Fig.2.4 V-I Characteristics Curve of Diode.....	14
Fig.2.5 555 Timer IC.....	16
Fig.2.6 Astable Circuit.....	17
Fig.2.7 Square waveform of 555 Astable Output.....	17
Fig.2.8 555 Monostable Circuit.....	18
Fig.2.9 555 Monostable Waveform.....	18
Fig.2.10 555 Bistable Circuit.....	19
Fig.2.11 Relay Circuit	20
Fig.2.12 Transformer Circuit.....	21
Fig.3.1 Power Supply Unit.....	23
Fig.3.2 Circuit Diagram of Bridge Rectifier.....	24
Fig.3.3 Filter Circuit.....	26
Fig.3.4 Complete Circuit of the Alarm System.....	32

CHAPTER ONE

1.1 Introduction

The high rate of insecurity in Nigeria today due to losses of lives and properties has made it necessary to seek an alternatives and cheap means with modern technology. From the time immemorial the issue of security had been a very serious concern to human being.

Alarm systems are systems which operate warning device after the occurrence of an abnormal or dangerous condition [1]. Today, there are various forms of alarm systems used in detection of an unauthorized entry each one with its merits and demerits. But some facts needed to be considered for choosing a particular alarm system which must have a unique advantage of perceiving an intrusion without subjection to a false alarm production. The presence of some unwelcome guests and thefts in houses, places of work in a defined area especially in this era of economic downfall, making many people to look for alternatives in a wrong direction by intruding houses, cars to steals what is not theirs, has been posing a great problem in our society. This calls for a sensitive and reliable security or alarm system for detection and indication of intruders so that protective measures can be taken to combat their attacks.

Light sensitive alarm is an alarm system which has a unique advantage of perceiving an intrusion without subjection to a false alarm if a beam of light is arranged to fall on the light sensor. This alarm system has an advantage trigger ON when a light beam is deflected once an unwelcome guest is detected.

In this age of very loose security, stolen cars or valuable properties from houses and other places were being announced almost every day in our media without any later recovery and due

to this disheartening state of safety and economy, it is inevitably necessary to sit down, design and construct a reliable security system which can be used to detect and implicate the presence of an intruder so that workable measures can be taken. This threatening issue of our time leads to the design and construction of light sensitive alarm system to detect the presence of an intruder by alerting us so that needed urgently can be taken.

Also , one of the ways that have been able to achieve this has been in the area of energy efficient light bulbs and fluorescent tubes. These innovative measures will reduce power intake to an appreciable extent, but the major saving has been achieved by ensuring that only the lighting point that are needed are kept on at any time which those in place where the level of illumination is high enough are turned off, which has made it through the use of what is known as light – sensitive alarm. There are several alarm systems as a device but that of a light-sensitive type is a perfect device having added advantage of minimizing the power consumed by the users through to be discussed in the succeeding chapters of this project and switching on at appropriate time.

The need for the construction of the light sensitive alarm as a security device is indispensable and highly unavoidable necessary because it is able to do this with lesser involvement of manual operators which is a big advantage for reducing operational cost for the usage for either big or small organizations. There have been various kinds of accidents and security deterioration in homes, workplaces, streets due to the irregularities brought about by human factor, but with the availability of light sensitive alarm, insecurity rate and accident prone to unlit area in our surroundings will be of zero tolerance.

Generally, when we talk about light sensitive alarm, we talk about the combination of alarm circuit and a battery. The battery keeps the alarm serving its purpose when the mains AC

power supply fails. The alarm circuit detects a sudden shadow falling on the light sensor and sounds the bleeper when this happens and will not response to gradual changes in brightness to avoid false alarms. This alarm needs to be designed to handle the requirement of security hungry household. Alarms can be designed in a number of ways depending on the situation and its requirements. The efficiency of this alarm is highly dependable on the switching device, topology and frequency of the alarm.

The aim of this thesis is to produce an efficient light-sensitive alarm system with 9volts dc battery as a back-up if mains supply fails for security reason. This project provides a detailed and comprehensive analysis, designed and construction of this light-sensitive alarm.

The sensitivity of this alarm can be conditioned or varied to suit a time the light should come on or trigger a particular circuit. This alarm works on the principle of light reflection or deflection of light. That is, the alarm will be triggered when shadow falls or light falls on the circuit by the intruder.

This device needs little or no maintenance once it is installed but the sensor must be constantly kept exposed to light from laser diode. Its capacity varies from the switching of single bulb in the house to a roll of street light on the street and along roads.

The importance and function of this alarm cannot be done away with but can only be modified to meet all times demand.

1.2 Aim

The aim of this project is to design and construct light sensitive alarm for protection of lives and properties.

1.3 Objective

The objective of the project is as follows;

- To improve the security measures in preventing loss of lives and properties at a reduced operational cost.
- To acquaint me with basic tools and materials in electrical and computer and develop my skill in their use.
- To improve my skills in both theory and practice of circuit analysis.
- To encourage research and methods for data acquisition.
- To design and construct a relatively cheap and less maintenance light sensitive alarm for use in homes and various establishment.

1.4 Methodology

The alarm system uses simple techniques to function, when the circuit is being powered by 12V DC, the 6v Relay RL becomes active and thus completing the circuit of the 555 timer IC and 5v regulator. The LASER diode is powered by the 5v regulator then by focusing its beam on the LDR and dropping its resistance from $600\text{k}\Omega$ - 150Ω , which causes the base of the trigger transistor to be pulled up to V_{cc} . The 22k, 100k variable and $10\mu\text{f}$ 16v forms the RC network of the timer. The timer IC is configured in monostable mode.

When the circuit is armed, all it needs to trigger is an opaque object coming in between the LASER beam and the LDR sensor. Once this happens LDR resistance becomes higher than $10\text{k}\Omega$ and this will cause fixed value $10\text{k}\Omega$ to pull the base of trigger transistor to the ground thus causing pin3 to go higher and trigger the buzzer alarm. The alarm will continue sounding until it is reset from the reset switch which pulls pin4 to the ground and thus resetting the timer causing the output pin3 to go low once again.

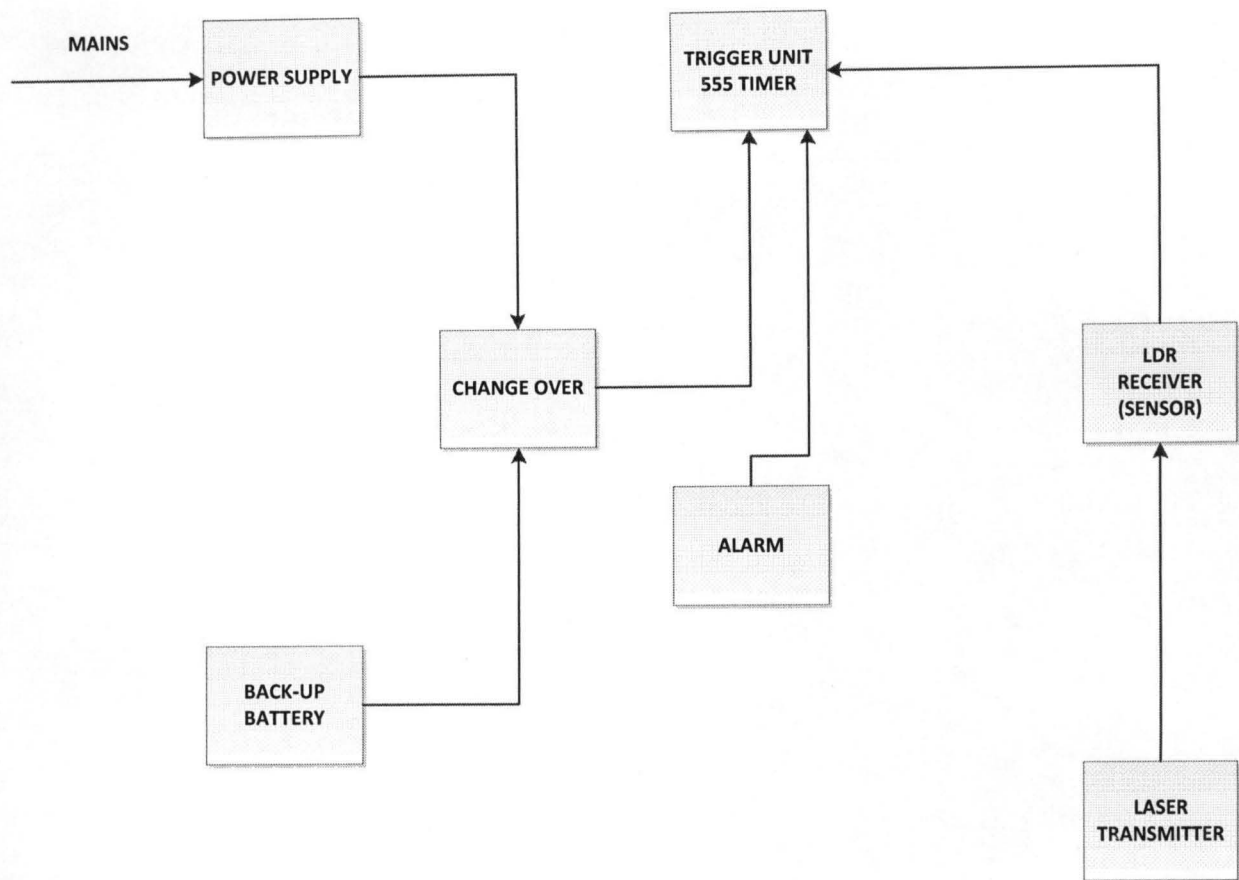

Fig.1.1 Block Diagram of the Project

1.5 Scope/Limitation

The scope of the project is limited by some factors, in which one of them is the passive means of climatic control. The light sensor is a LDR (light dependent resistor) having power rating of 80mW with low a low resistance in bright light and a high resistance in dim light. If the circuit is switched on continuously 9V battery will last for about a month, but for longer life a pack of 6 AA alkaline batteries can be used.

1.6 Project Outline

This project work is broken down into five chapters and each chapter deals with the following aspects:

Chapter one gives a general introduction of what the project is all about, its aims and objectives, methodology and scope of the project.

The previous work done with respect to the project is discussed as the literature review of chapter two.

Chapter three covers the various steps taken in the design and implementation of the project work and calculations involved.

The test carried out, result obtained and discussion of such result comes under chapter four. The conclusion and recommendation constitutes chapter five.

CHAPTER TWO

2.0 Theoretical Background

There have been a large number of literature reviews written concerning light sensitive alarm in the recent years. This can be attributed in part to the rise in popularity of security alarm systems and their integration with existing ones. There is also a consistent demand for high efficiency security alarm systems for security measures in various places like houses, offices and remote areas of the world. This chapter will discuss and contrast recent literature concerning light sensitive alarm systems.

The basic function of a security alarm is to detect as fast as possible an authorized entry into defined area. Furthermore, the ideal security system should also be difficult to by-pass or override and must be highly reliable and operate under adverse conditions. That is should be subject to false alarming. In security alarm systems, these are two basic categories:

I **Perimeter Detections:** This is the most common type that has to do with perimeter intrusion detection which essentially consists of different type of switches. These are detectors that protect the circumference of an area by using magnetic switches. When the magnet is moved away from the switch it triggers an alarm and its otherwise called Ribbon type-which always installed at entrance point of the area to be protected. Stepping on the closes an electrical contacts, thus triggering an alarm. The disadvantage of this category is that it can be "jumped" by paralleling the electrical connection prior to breaking.

II **Space Intrusion Detections:** These are device which can detect an intrusion in volumetric (3 dimensional) space and generates an energy yielded in all direction with one major

advantage of not allowing an intruder to pass through its energy field before the intruder can get to the device; so intruder, might not be able to “jump” or cut off its power supply. But passage of small animals can trigger the alarm which limits its function as alarm.

Owing to this disadvantage, design and construction of light sensitive alarm is chosen and stand a better chance to overcome the shortcoming of the above mentioned categories of alarms by detecting intrusion during the days and night and not seasonal.

2.1 Electronic Components

2.1.1 Capacitor

A capacitor (formerly known as condenser) is a passive electronic component consisting of a pair of conductors separated by a dielectric (insulator). When there is a potential difference (voltage) across the conductors a static electric field develops in the dielectric that stores energy and produces a mechanical force between the conductors. An ideal capacitor is characterized by a single constant value, capacitance, measured in farads. This is the ratio of the electric charge on each conductor to the potential difference between them.

Capacitors are widely used in electronic circuits for blocking direct current while allowing alternating current to pass, in filter networks, for smoothing the output of power supplies, in the resonant circuits that tune radios to particular frequencies and for many other purposes.

The effect is greatest when there is a narrow separation between large areas of conductor; hence capacitor conductors are often called "plates", referring to an early means of construction. In practice the dielectric between the plates passes a small amount of leakage current and also has

an electric field strength limit, resulting in a breakdown voltage, while the conductors and leads introduce an equivalent series resistance.

In October 1745, Ewald Georg von Kleist of Pomerania in Germany found that charge could be stored by connecting a high voltage electrostatic generator by a wire to a volume of water in a hand-held glass jar [2].

Practical capacitors are available commercially in many different forms. The type of internal dielectric, the structure of the plates and the device packaging all strongly affect the characteristics of the capacitor, and its applications.

Values available range from very low (picofarad range; while arbitrarily low values are in principle possible, stray (parasitic) capacitance in any circuit is the limiting factor) to about 5 kF supercapacitors.

Above approximately 1 microfarad electrolytic capacitors are usually used because of their small size and low cost compared with other technologies, unless their relatively poor stability, life and polarized nature make them unsuitable. Very high capacity supercapacitors use a porous carbon-based electrode material.

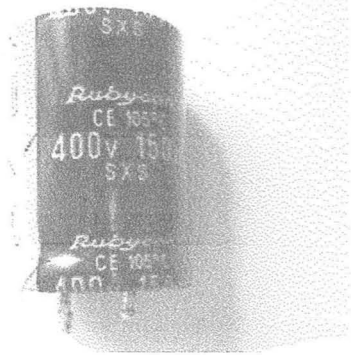

Fig.2.1a A Capacitor Diagram

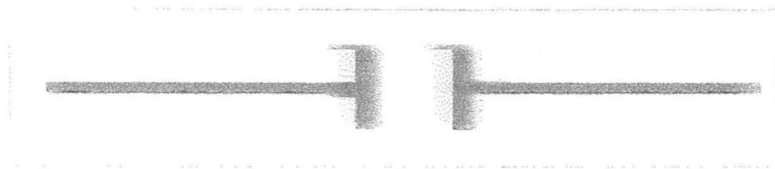

Fig.2.1b A Capacitor Symbol.

2.1.2 Resistor

A resistor is a two-terminal electronic component that produces a voltage across its terminals that is proportional to the electric current passing through it in accordance with Ohm's law:

$$V = IR$$

Resistors are elements of electrical networks and electronic circuits and are ubiquitous in most electronic equipment. Practical resistors can be made of various compounds and films, as well as resistance wire (wire made of a high-resistivity alloy, such as nickel/chrome).

The primary characteristics of a resistor are the resistance, the tolerance, maximum working voltage and the power rating. Other characteristics include temperature coefficient, noise, and inductance. Less well-known is critical resistance, the value below which power dissipation limits the maximum permitted current flow, and above which the limit is applied voltage. Critical resistance is determined by the design, materials and dimensions of the resistor.

Resistors can be integrated into hybrid and printed circuits, as well as integrated circuits. Size, and position of leads (or terminals) are relevant to equipment designers; resistors must be physically large enough not to overheat when dissipating their power.

The ohm (symbol: Ω) is the SI unit of electrical resistance, named after Georg Simon Ohm. Commonly used multiples and submultiples in electrical and electronic usage are the milliohm (1×10^{-3}), kilo-ohm (1×10^3), and mega-ohm (1×10^6).



Fig.2.2 Resistors

2.1.3 Diode

This is a two terminal device consisting of a P and N junction formed either in Ge or Si crystal. The P and N type regions are referred to as anode and cathode respectively. Its circuits symbol shown below. The V-I characteristics in fig. 2.1.3 shows the static voltage-current characteristic for a low power P-N junction diode [3].

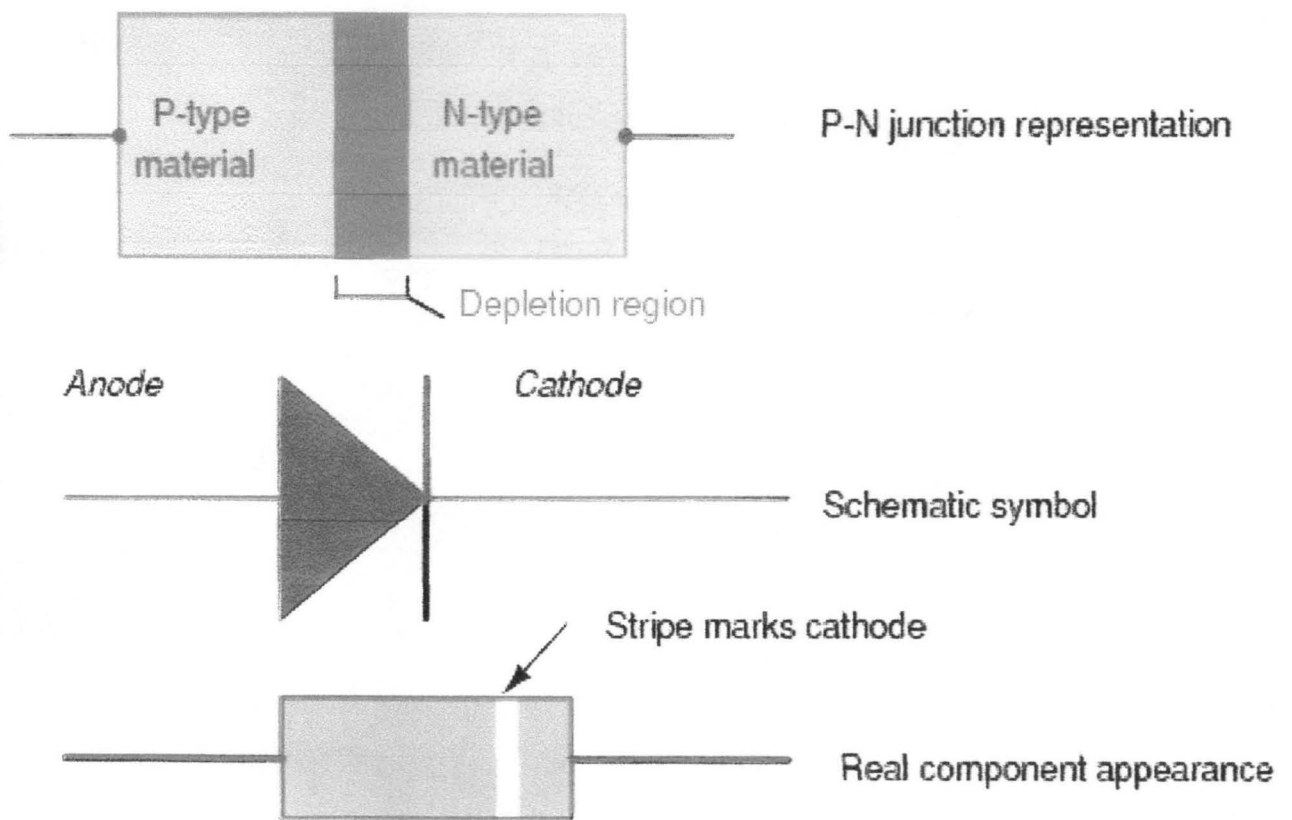

Fig.2.3 Diode

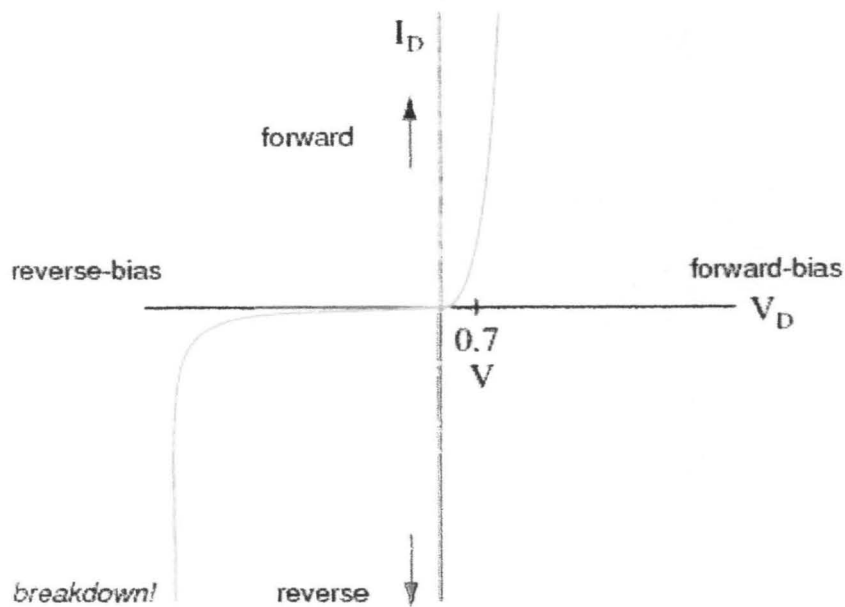

Fig.2.4 Diode V-I Characteristics Curve

2.1.4 Laser Diode

A laser diode is a laser where the active medium is a semiconductor similar to that found in a light-emitting diode. The most common type of laser diode is formed from a p-n junction and powered by injected electric current. The former devices are sometimes referred to as injection laser diodes to distinguish them from optically pumped laser diodes.

2.1.5 Light Dependent Resistor

A photo resistor or light dependent resistor or cadmium sulfide (CdS) cell is a resistor whose resistance decreases with increasing incident light intensity. It can also be referred to as a photoconductor.

A photo resistor is made of a high resistance semiconductor. If light falling on the device is of high enough frequency, photons absorbed by the semiconductor give bound electrons enough energy to jump into the conduction band. The resulting free electron (and its hole partner) conduct electricity, thereby lowering resistance.

A photoelectric device can be either intrinsic or extrinsic. An intrinsic semiconductor has its own charge carriers and is not an efficient semiconductor, e.g. silicon. In intrinsic devices the only available electrons are in the valence band, and hence the photon must have enough energy to excite the electron across the entire band gap. Extrinsic devices have impurities, also called dopants, added whose ground state energy is closer to the conduction band; since the electrons do not have as far to jump, lower energy photons (i.e., longer wavelengths and lower frequencies) are sufficient to trigger the device. If a sample of silicon has some of its atoms replaced by phosphorus atoms (impurities), there will be extra electrons available for conduction. This is an example of an extrinsic semiconductor.

2.1.6 555 Timer IC

The timer IC is an amazingly simple yet versatile device. The two primary versions are original bipolar design and the more recent CMOSs equivalent. These differences primarily affect the amount of power they required and their maximum frequency of operation, they are also in pin compatible functionally interchangeable.

The fig.2.1.6 below shows the functional block diagram of 555 timer IC. The IC is available in either an 8-pin round or 8-pin mini DIP package.

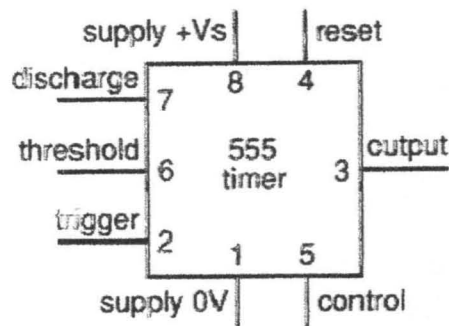

Fig.2.5 555 Timer IC

2.1.7 555 Astable

An astable circuit produces a 'square wave', this is a digital waveform with sharp transitions between low (0V) and high (+Vs). Note that the durations of the low and high states may be different. The circuit is called an astable because it is not stable in any state: the output is continually changing between 'low' and 'high'.

The time period (T) of the square wave is the time for one complete cycle, but it is usually better to consider frequency (f) which is the number of cycles per second.

$$T = 0.7 \times (R1 + 2R2) \times C1 \quad \text{and} \quad f = \frac{1.4}{(R1 + 2R2) \times C1}$$

T = time period in seconds (s)

f = frequency in hertz (Hz)

R1 = resistance in ohms (Ω)

$R2$ = resistance in ohms (Ω)

$C1$ = capacitance in farads (F)

The time period can be split into two parts: $T = T_m + T_s$

Mark time (output high): $T_m = 0.7 \times (R1 + R2) \times C1$

Space time (output low): $T_s = 0.7 \times R2 \times C1$

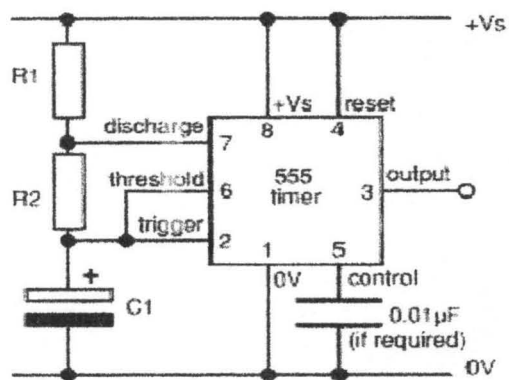

Fig.2.6 555 Astable Circuit



Fig.2.7 Square wave form of 555 Astable Output

2.1.8 555 Monostable

A monostable circuit produces a single output pulse when triggered. It is called a monostable because it is stable in just one state: 'output low'. The 'output high' state is temporary.

The duration of the pulse is called the time period (T) and this is determined by resistor R1 and capacitor C1:

$$\text{time period, } T = 1.1 \times R1 \times C1$$

T = time period in seconds (s)

R1 = resistance in ohms (Ω)

C1 = capacitance in farads (F)

The maximum reliable time period is about 10 minutes.

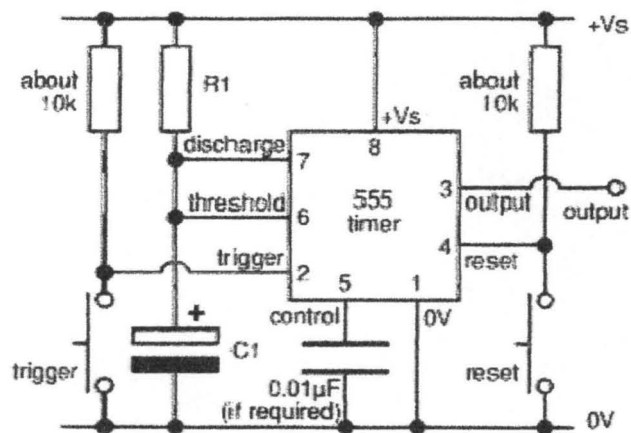

Fig.2.8 Monostable Circuit with Manual Trigger

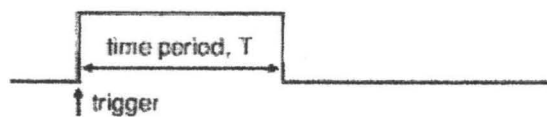

Fig.2.9 Monostable Output, a Single Pulse

2.1.9 555 Bistable (flip-flop) – A Memory Circuit

The circuit is called a bistable because it is stable in **two** states: output high and output low. It is also known as a 'flip-flop'.

It has two inputs:

- **Trigger** (555 pin 2) makes the **output high**.
Trigger is 'active low', it functions when $< \frac{1}{3} V_s$.
- **Reset** (555 pin 4) makes the **output low**.
Reset is 'active low', it resets when $< 0.7V$.

The power-on reset, power-on trigger and edge-triggering circuits can all be used as described above for the monostable.

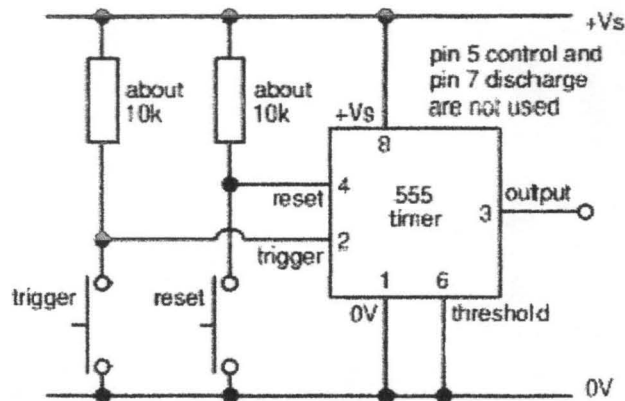

Fig.2.10 555 Bistable Circuit

2.1.10 Relay

A relay is a device that is used to perform electrical switching function. It performs the same function as a switch, except that is electrically operated instead of being manually operated.

An electromagnetic relay is basically a switch operated by magnetic force. This magnetic force is generated by flow of current through a coil in the relay. The relay opens or closes a circuit when current through the coil is started or stopped. A circuit using relay normally has two separate circuits. One circuit which contains the relay is called "switching circuit". The circuit drives the relay to switch ON/OFF. Another circuit is known as "switched circuit".

Relays are available in single, double and triple pole configuration. Since relays are electrically operated, unlike traditional switches, they can be opened or closed from a remote location. Generally, relays are made for voltages 6, 12, 18, 24, 48, 110, 240AC or DC. Coil resistance is usually given which helps in calculating the coil current and power dissipation on the coil.

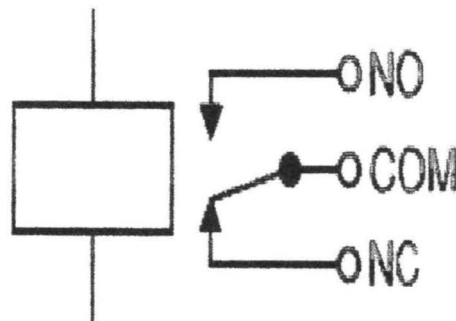

Fig.2.11 Relay

2.1.11 Transformer

Transformer is a static or stationary piece of apparatus by means of which electronic power in one circuit is transformed into electric power of the same frequency in another circuit. It can raise or lower the voltage in a circuit but with a corresponding decrease or increase in current. [3]

Types of Power Transformer

- Step-up Transformer
- Step-down Transformer

Step-up Transformer:- The number of turns in the secondary winding is twice the number of turns in the primary winding, so the voltage across the secondary windings is twice that of the primary winding, meaning that the output voltage is twice or more than the input voltage.

Step-down Transformer: - The number of turns in the primary winding is twice the number of turns in the secondary winding. The voltage across the primary windings is twice that of the secondary winding, meaning that the output voltage is half of the input voltage.

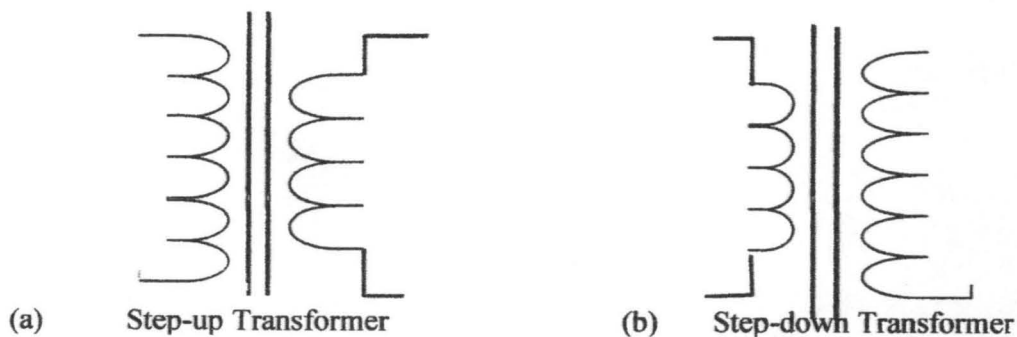

Fig.2.12 Types of power Transformer

2.1.12 9V Battery

This is a primary battery that is being designed for a single discharge cycle and nonrechargeable. It is used as a backup if power from mains fails.

2.1.13 Buzzer

A buzzer is employed in line with the PNP transistor (BC 557) to serve as speaker in order to boost the audio signal to high level so that the output can be heard.

CHAPTER THREE

3.0 Design and Implementation

In this module, the parameter of the component that will be used in this design will be calculated. There are various stages in this light sensitive alarm.

3.1 The Power Supply Unit

This unit supplies a regulated power to the alarm circuit. It is made up of the transformer, rectifier, filter, voltage regulator, requiring 12V DC supply. Power to the system must be supplied from a reliable source and a standby alternate power source is more desirable because security check must be on a constraint basis. The one used for this project is a 220/12V/500mA step-down transformer with the 220V as its primary voltage (V_1) and 12V as its secondary winding voltage (V_2).

3.1.0 Transformer Operation

When an alternating voltage is applied to a transformer i.e. through the primary winding (N_1) limited in value by the inductance of the winding flow. This magnetizing current produces an alternating magnetomotive force (mmf) which operates an alternating magnetic flux (Φ) in Weber. The flux is constrained within the magnetic circuit and induces a voltage in the linked secondary winding (V_2) which produces an alternating current if it is connected to an electric load. This secondary load (I_2), in turn produces its own mmf (E) and creates a further alternating flux which links back with the primary winding (V_1).

The transformer should be rated 12V/500mA. Also the diode D1 to D4 is IN4001 which has a current capacity of 1000mA. The value of the smoothing capacitor C1 is given by the formula below

$$C \geq \frac{1}{2\sqrt{3WR\alpha}}$$

Where $W = 2\pi f$

α = ripple factor = 0.1

R = ripple factor

$$C = \frac{1}{2\sqrt{3 \times 2\pi \times 50 \times 0.1 \times 100}} = 5150\mu\text{F}$$

$$C = 5600\mu\text{F}$$

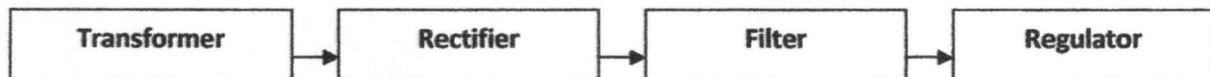

Fig.3.1 Power Supply Unit

3.1.1 Transformer Specification

The Transformer used for this project is a 12V, 500mA Voltage Transformer. This transformer was not rewound since it was readily available in the market.

3.1.2 Rectifier

Rectifier diodes connected in a bridge are used in the circuit to convert AC to a pulsating DC. For typical low current rectifiers, the Diode drops about 0.7V, this is the value that will be used for the purpose of analysis.

For a full wave bridge rectifier, two diodes are always conducting while the other two will be in the off state.

D2 and D4 conducts during the period $t=0$ to $t=T/2$ while D1 and D3 are in the non-conducting state. And during the period $t=T/2$ to T , D1 and D3 will conduct while D2 and D4 will be in the off state.

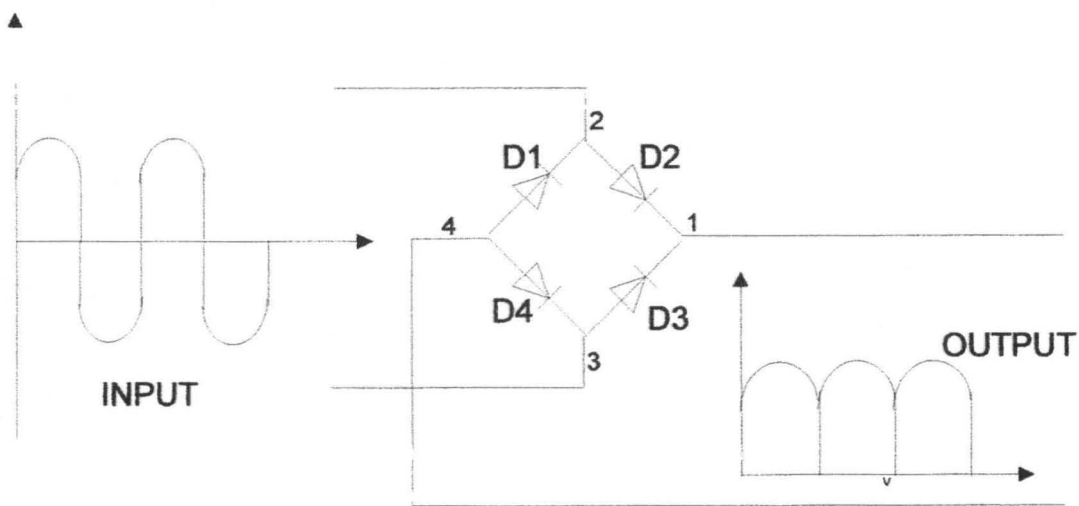

Fig.3.2 Circuit Diagram of Bridge Rectifier.

The output of a bridge rectifier is given as:

V_p = peak value of the Ac voltage being rectified

$$V_{p,out} = V_{p,Sec} - 2V_d$$

Where $V_{p,out}$ = peak output voltage

$V_{p,sec}$ = peak of the secondary voltage

$$V_{p,sec} = V_m \sqrt{2}$$

V_m = maximum input voltage

V_d = diode voltage drop (0.7V)

From above parameters given, it can be deduced that;

$$V_{p,out} = V_m\sqrt{2} - 2 \times 0.7$$

Recall that the output of the transformer is 12Volts,

This implies that $V_{p,out} = 12\sqrt{2} - 2 \times 0.7 = 15.571$ Volts

Rectifier diodes are rated by the maximum current they can pass and the maximum RMS voltage they can withstand. IN4001 rectifier diode is used for this project.

3.1.3 Filters

Full wave rectified voltage is filtered by a capacitor. Electrolytic capacitors are used as a ripple filter in a power supply circuit. They have polarity; that is to say they have positive and negative electrodes. It is therefore important to note the particular way they are connected. When using electrolytic capacitor one must pay attention to the maximum voltage, which can be used. This is the breakdown voltage. The breakdown voltage is the voltage that when exceeded will cause the dielectric (insulator) inside the capacitor to breakdown and conduct. Electrolytic capacitor which is connected in parallel to the output of the rectifier to perform smoothing; this reduces the ripple, smoothing is not perfect due to the capacitor voltage falls a little as it discharges given a small ripple voltage. The output of a filter capacitor is as shown below.

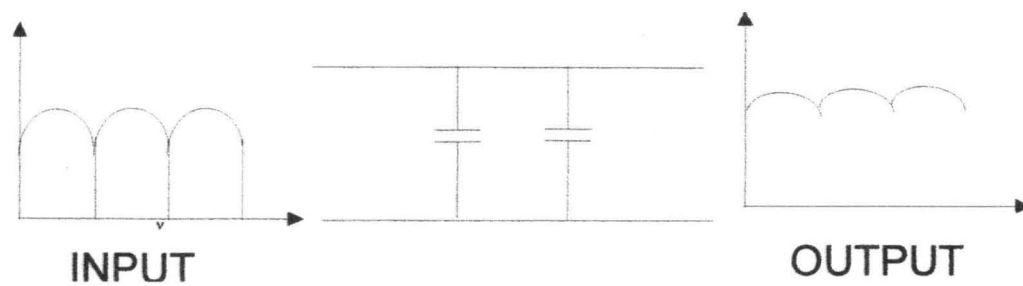

Fig.3.3 Diagram of a Filter Circuit.

One of the important ratings of a power circuit is the ripple factor.

Ripple factor is defined as;

$$r_f = \frac{V_{rip}}{V_{dc}} \times 100\%$$

So ripple voltage can be calculated in terms of the circuit parameters shown below;

$$V_{rip} = \left[\frac{I_{dc}}{2fc} \right]$$

Where I_{dc} = load current in Ampere

f = frequency in Hertz

C = Capacitor value in farad

From ripple factor equation

$$V_{rip} = r_f \times V_{dc} = \frac{I_{dc}}{2fc}$$

By making C the subject of the formula;

CHAPTER FIVE

5.0 Conclusion and Discussion

Clearly, despite the type of outcome of a research and development project of this kind, conclusions can be drawn that will aid further research into the area. This project provides considerable ground for additional research – in number of areas –and also brings to light some lessons to be learnt in security alarm design.

This project was aimed at providing an alternative to the insecurity problem. It was also aimed to provide a solution to the erratic nature of insecurity in this country.

Knowing that quality cannot be built into a components but the standard of the design would determine the reliability of the device, care was taken at every stages of the project.

The light sensitive alarm is a viable security alarm with low maintenance and operational cost useful for houses, streets with battery incase of power failure. To achieve a longer time if mains fails, battery banks are required.

5.1 Recommendation

It is justifiable to say that this project work is more economical than those imported from the developed countries which are at exorbitant prices and incorporation of battery bank into the system so that security and safety will be achieved because power failure to the system is equivalent to insecurity.

Hence, it will go a long way to reduce crime rate and many problems of insecurity to a low level in Nigeria.

In conclusion, security is very paramount and safety is needed for our properties, assets and lives.

REFERENCES

- [1] www.google.com
- [2] www.wikipedia.com
- [3] B. L THERAJA, A.K THERAJA (2002) : A Textbook of Electrical Technology, S Chand Comp. New Delhi, India. Pp1029-1033
- [4] PROF. ORIA USIFO (2005) ; Research Project Implementation Made Easy In Electrical & Electronics Engineering, ECAS Vol. One. First Edition, pp332 -337.
- [5] DONALD A. NEAMAN (2001) Electronics Circuit Analysis and Design. Second Edition, Mc-Graw Hill Education, pp. 475-476.