

**DESIGN AND CONSTRUCTION OF A MICROCONTROLLER BASED DIGITAL
LOCK**

BY

DARE SAMUEL EKUNDAYO

2006/24400EE

**A THESIS SUBMITTED TO THE DEPARTMENT OF ELECTRICAL AND
COMPUTER ENGINEERING, FEDERAL UNIVERSITY OF TECHNOLOGY,
MINNA. IN PARTIAL FULFILLMENT OF THE REQUIREMENT FOR THE
AWARD OF BACHELOR OF ENGINEERING DEGREE (B. ENG) IN
ELECTRICAL AND COMPUTER ENGINEERING.**

November, 2011

DECLARATION

I Dare Samuel Ekundayo declare that this project was executed by me under the supervision of Engr. A.G. Raji, and that the project, to best of my knowledge has not been submitted for any degree elsewhere. All the reference, extractions were fully acknowledged.

Dare Samuel Ekundayo

Student

Dare Samuel Ekundayo 09/11/2011

Signature and Date

CERTIFICATION

This is to certify that this project title "Design and construction of a microcontroller based digital lock" has met the requirement governing the award of B.Eng. Electrical and Computer Engineering, Federal University of Technology, Minna.

Engr. A.G Raji

Project Supervisor

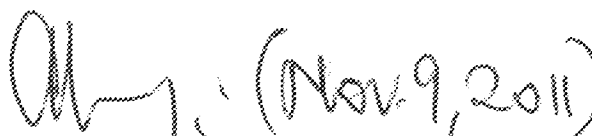
 (Nov. 9, 2011)

Signature and Date

Engr. A.G Raji

Head of Department

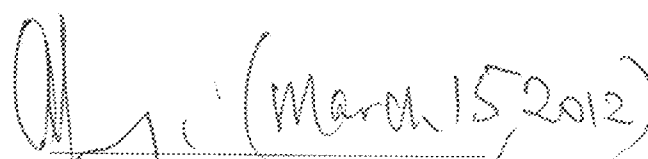
 (March 15, 2012)

Signature and Date

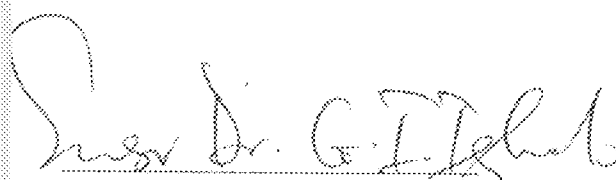

External Examiner

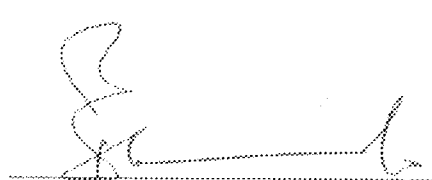
 6/3/02

Signature and Date

DEDICATION

This project work is dedicated to my Father in heaven, the Almighty God who in His infinite mercies, His precious and unfailing love has granted me the strength and inspiration all through my work and to my wonderful and lovely parents Mr. and Mrs E.O. Dare. May almighty God continue to bless you.

ACKNOWLEDGEMENT

I am very much indebted to God Almighty, who has kept me all through these years. My profound appreciation goes to my wonderful parents who have always been there for me, supporting me morally, financially and spiritually. I cannot thank you enough. I particularly appreciate the efforts and contributions of my elder sister, Dr (Mrs) Roseline Samuel and younger brother, Oluwarotimi Dare towards my success in academics and life generally. Your contribution has stood out distinguished and remains incomparable. All members of my family are not left out either, your individual contributions are innumerable. On a special note I wish to appreciate the family of Mr. and late Mrs. Akande, thank you for your love, prayers, kindness and understanding. My deep appreciation goes to my supervisor, Engr. A.G. Raji, the (H.O.D) of Electrical and computer Engineering department for his kindness, attention, constructive criticism, advice and understanding. The precious time he spent in going through my manuscript is acknowledged. I am glad to have worked under him. I wish to also acknowledge the enormous contribution of Mallam Umar Abubakar, the technician of Electrical and computer Engineering department and to all the lecturers and entire staff of the university for their assistance and contribution either directly or indirectly throughout my stay in the university.

My appreciation is further extended to Mr. Bayo Tade, (My big brother), Dr. Olukayode Samuel, Mr. Paul Benson Owoleke, Mr. J. Onoja, Arc. Adetunji Arokoyo and to my friends which are too numerous to mention due to inadequate space for their various contributions. God bless you all.

ABSTRACT

This project presents the design and construction of a Microcontroller-Based Electronic lock. This device is a hybrid software and hardware prototype, which automatically protect the device connected to it from unauthorized access. This system is designed such that only user with the correct password are allowed to gain access while other users who are ignorant of the authentic code are denied. A keypad interface is provided which allows the user to input the key code. The inputted key is then compared with the authorized access code which has been preset by the user. If the correct code is entered by the user, access is allowed otherwise the user is denied. The rightful owner of the device can at anytime change the security code of the system. A display unit, interfaced to this system, displays status message to guide the user.

TABLE OF CONTENTS

Cover page	i
Dedication	ii
Acknowledgment	iii
Declaration	iv
Certification	v
Abstract	vi
Table of contents	vii
CHAPTER ONE	
Introduction	1
Historical background	2
Aims and objective	2
Methodology	3
Scope of the Project	3
CHAPTER TWO	
Literature review	5
Locks from the orient	5
First in the development of locks	5
German castle lock	6-7
Mechanical lock	8
Magnetic lock	9

Electronic lock	10
CHAPTER THREE	
Design and Implementation	11
The power supply unit	12
The Transformer	13
The rectifier	13
The filters	14
Voltage regulator	15
Control unit	16
AT89C52 Micro controller	16
Switching unit	17
Relay	17
Relay operation	17
Relay applications	18
Diodes	19 – 20
Transistors	21
Display unit	22
Pin description	22
Design of power supply unit	23
Rectifier selected for circuit	24 – 25
Regulator selection	26
The control unit	26 – 27
Design pin description of the control unit	28

Design of the switching unit	28 – 29
Design of the display unit	30
LCD pin description	31
Design of the keypad unit	32
The PIC programmer	33
Alarm	33
Software designing	34
Display program	34
Keypad program	34
Design Flow Chart	35-37
Complete design circuit diagram	38

CHAPTER FOUR

Construction, Testing and results	39
Hardware construction	40
Construction precautions	40
Keypad testing	41
LCD testing	41
Testing and results	41
Problems encountered	42

CHAPTER FIVE

Conclusion	42
Recommendation	43
Reference	44
Appendix	

LIST OF FIGURE

Fig 2.1	Diagram of mechanical lock.....	8
Fig 2.2	Diagram of a magnetic lock.....	9
Fig 2.3	Diagram of and electronic lock.....	10
Fig 3.1	Block diagram of a microcontroller based digital lock.....	11
Fig 3.2	Power supply block diagrams and waveform.....	12
Fig 3.3	Transistor circuit symbol.....	13
Fig 3.4	Circuit diagram of a full wave rectifier.....	13
Fig 3.5	Diagram of voltage regulator.....	15
Fig 3.6	Symbol of relay.....	18
Fig 3.7	Characteristic diagram of a silicon diode.....	19
Fig 3.8	Symbol of diode.....	20
Fig 3.9	Symbol of NPN and PNP transistors	21
Fig 3.10	Diagram of LCD.....	22
Fig 3.11	Circuit diagram of power supply unit.....	23
Fig 3.12	Rectifier unit.....	24

Fig 3.13	Filtering unit.....	25
Fig 3.14	Regulation unit.....	26
Fig 3.15	Pin description of AT89C52 microcontroller.....	28
Fig 3.16	Diagram of AT89C52 microcontroller.....	28
Fig 3.17	Circuit diagram of switching unit.....	29
Fig 3.18	Circuit diagram of display unit.....	30
Fig 3.19	Circuit diagram of keypad unit.....	32
Fig 3.20	Schematic diagram of programming the control unit.....	33
Fig 3.21	Flow chart diagram.....	35 – 37
Fig 3.22	Complete circuit diagram.....	38
Fig 4.1	Continuity test of keypad.....	41

LIST OF TABLE

Table 4.1	Result of power supply unit.....	41
Table 4.2	Result of display unit.....	42

CHAPTER ONE

1.1 INTRODUCTION

One of the basic rights of human population is the provision of adequate securities for both lives and properties. In an attempt to make sure that the right are not infringed on, different forms of security measures are put in place, these range from the use of security guards (police officers, private guards etc.), to audio warning devices (alarms, sensors etc) and so on. Due to advancement in technology, more recent forms of security measures are being introduced into the market, surveillance cameras and integrated access control through Biometric access control and Data base to accurately monitor access to a specific door (s) where security measures are installed.

However, the use of mechanical systems e.g. devices for security locks cannot be overemphasized. Simple lock and bolt made from forged metals, the door chain, the jam lock and the pad lock are examples of such devices. The most important similarity common to all the different security systems or mechanism is that they grant unauthorized users access to a particular door(s). Meanwhile, it should be noted that these devices both mechanical and biometric access systems have limitations and shortfalls, the mechanical system (simple jam and lock) can be forced open or keys can be duplicated by mischievous individuals and there might be problem of recognizing the authentic individual concerned, when it comes to Biometric.

Biometric access controls are also very expensive and requires skills or skilled labour to install. To this effect, it is necessary we create or produce a locking system that is reliable, efficient, and inexpensive and has a high discriminative capability, hence, the construction of a micro controller based digital lock that incorporates the use of Data base systems that enables particular user/users to gain access. This in turn increased the complexity of access

systems. It can be used in homes, hotels or military application, but this project will cover its use in homes.

1.2 Historical Background

Day after day the civilization of man increases and his quest for security also increases. In the past, there were no much need for locks and probably burglary proofs. this reason is as a result of man's contentment and high moral value.

As time went by, cultural infiltration and other vices polluted the people making stealing very rampant in the society. So everybody became conscious and started to put their valuables under lock and key. The advent of lock and key could only stem the tide of burglary for a little while because the duplication of key takes a little above ten minutes. The duplicator gets its mark on soap or other material of same hardness. They get these marks by imprinting the key on the material (soap). Shortly after the lock and keys, there was an invention of padlock that uses combination of numbers for its opening. The problem with this particular padlock is its rigidity. It is the manufacturer that fixes the numbers and keeps the information of the lock until when it's going to be sold. So the user of this kind of lock could open it in the presence of an unsuspected thief which he can memorize the number and open it later.

Digital lock was introduced so that the opening with keys and the combinational number and the burglary that comes with it can be reduced. This digital lock also opens with numbers, but the numbers are codes or sets of codes that is not inputted physically into the circuit to open or close the lock.

1.3 AIMS AND OBJECTIVES

To provide a security lock that is efficient and reliable at a cheaper rate compared to the less efficient and less reliable device or locks that are quite expensive.

1.4 METHODOLOGY

Using a program written in Assembly language, the microcontroller controls the flow of all activities in the device. At power up the microcontroller send a "system ready" text to display at the LCD (Liquid crystal display) screen. The microcontroller then prompts the user for access code, before this a list of possible access codes are already stored in the non-volatile memory. The microcontroller now compares the characters entered with the right pin number in its external electrically erasable programmable read only memory (EEPROM) which is used as the data base. If the characters entered correspond to the stored pin code, it activates the port to which the door lock unit (manually fabricated) is connected and it opens, else it remains locked and the LCD display prompts the user to try again. But if the user continues to enter a wrong access code, the user will be denied access. Therefore, the microcontroller is responsible for controlling the process of opening and closing the door. All these steps are described in details in Chapter 3 of this project report.

It is interesting to know at this point that though the microcontroller are designed to perform a specific task, during design, the program can be altered to suite the end user requirement, for changing the welcome message display at the LCD and so on. This helps in creating variations of this project and at the same time, it improves its versatility.

1.5 SCOPE OF THE PROJECT

This project involves the design and construction of a microcontroller based digital lock which incorporates both hardware and software through the use of low level language (assembly language) written to a microcontroller (which is the principle behind the operation of the embedded system). The design basically covers technological development and advancement in security system.

This project is limited to access control only.

CHAPTER TWO

2.0 LITERATURE REVIEW.

Several practices both Conventional and unconventional have been carried out over the years towards ensuring the safety of lives and property. For instance man used stick and stones as a means of lock and key to safe guard his valuables, in the Stone Age. The desired security could however not be obtained.

The earliest lock in existense is the Egyptian lock made of wood, found with its key in the khorsabad palace ruins of Niniveh by Archeologist in ancient Assyria, it was found to be 4000 years old. It is a prototype of the modern cylindrical lock. Locks and keys were large and crude in design; yet their principle of operation was the forerunner of the modern pin-tumbler locks. As locksmiths and metal workers became proficient in their craft, they were invited to make locks and keys for the Royal Courts and for the churches and cathedrals in Europe. They excelled in elaborate and highly detailed ornamentation-often adapted to the religious theme.

In India, in the days of Emperor of Annam, valuables were sealed into large blocks of wood, which were placed on Small Island or submerged into surrounding pools of the inner courts of the palace. Here, they were protected by the Royal " guardian angel" a number of crocodiles kept on starvation rations so they were always hungry. To venture into the water meant certain death for the intruder. The legitimate approach to the treasure was to drug or kill the crocodiles.

For several hundreds of years, cords of ropes made of rush and fibres were used to "lock" doors and tie up walls. The legend goes; a knotted rope became a famous symbol of security. Intricately tied by Gordius, king of Phrygia, and known by his name, the Gordian knot screwed the yoke to the shaft of his chariot. Its untying was pronounced by oracles to be possible only by the man destined to conquer Asia. However, when Alexander the great

failed to undo the Gordian knot, he cut it swiftly with his sword, giving us the expression, "to cut the Gordian knot" meaning a bold, decisive action, effective when milder measures fail.

2.1 LOCKS FROM THE ORIENT.

Brass and Iron padlocks found in Europe and the far West were popularised by the Romans and the Chinese. They were particularly favoured because they were portable. They operated by keys that turned, screwed, and pushed. The push-key padlock was of simple construction, the bolt kept in locked position by the projection of a spring or springs. To unlock, the springs were compressed or flattened by the key, which freed the bolt and permitted it to slide back. Padlocks of this type are most universally used in the orient today. The decoration reflects the art of the countries, and shapes often took the form of animals - Dragons, Horses, Dogs, even Elephants and Hippopotamuses. Padlocks were often presented in pairs of gifts, with congratulatory message in coneiform.

2.2 FIRSTS IN DEVELOPMENT OF LOCKS.

The first mechanical locks, made of wood, were probably created by a number of civilizations at the same time. Record shows them in use some 4000 years ago in Egypt. Fastened virtually on the door post, the wooden lock contained movable pin or "pin tumblers", that dropped by gravity into openings in the cross piece or "bolt", and lock the door. It was operated by a wooden key with pegs or prongs that raised the number of tumblers sufficiently to clear the bolt so that it could be pulled back. This method of locking was the forerunner of modern pin tumbler locks.

The first all-metal lock appeared between the years 870 and 900, and was attributed to the English craftsmen. They were simple bolts made of iron with wards (obstruction) fitted round the keyholes to prevent tampering.

The first use of wards (fixed projection in a lock) was introduced by Romans who devised obstruction to "ward off" the entry or turning of the wrong key. Wards are notched

and cut into decorative designs, and warding became a basic locking mechanism for more than a thousand years. The first padlocks were "conical" locks as they could be carried and used where necessary. They were known in early times to merchants travelling ancient trade routes to Asia and Europe. New concepts for locking devices were developed in Europe in the 17th century. Early Bramah locks utilized a series of sliders in a circular pattern to provide exceptional security. Bramah is the oldest lock company in the world and is continuing to manufacture its famous mechanism 200 years later.

GERMAN CASTLE LOCKS

The period from the 14th through the 17th century was one of artistic accomplishment by superb craftsmen; locksmiths were skilled metal workers who were becoming internationally famous. They were invited to construct special locks for noblemen throughout Europe. Using designs of coats-of-arms and symbolic shapes, they devised intricate wards and bits for locks and keys and were inspired to produce increasingly ornamental locks to harmonize with the architecture of their clients' estate or castle. However, there were few improvements in locking mechanisms. Security depended upon intricacies such as hidden key holes, trick devices, and complicated warding.

The first serious attempt to improve the security of the lock was made in 1778 in England. Robert Barron patented a double-acting tumbler lock. Joseph Bramah patented the safety lock in 1784. Bramah's lock was considered unpickable.

The inventor went on to create a hydrostatic machine, a beer-pump, a four-cock, a quill-sharpener, a working planer, and more. In 1857, James Sargent invented the world's first successful key changeable combination lock. His locks became popular with safe manufacturers and the United States Treasury Department.

In 1873, Sargent patented a time lock mechanism that became the prototype of those being used in contemporary bank vaults.

The ward lock which is the simplest form of lock is essentially a bolt containing a notch known as talon. The bolt is moved backward or forward by engaging a key in the talon. A back spring attached to the bolt holds it in place, once it is released by the key. The tumbler or lever lock, similar to the ward lock, contains one or more pieces of metal of different heights, known as tumblers, levers or latches, which intercept the bolt and prevent it from being moved until the tumblers, are raised or released by the action of an appropriate key.

The Yale lock, introduced about 1860 by the American inventor Linus Yale, was the first device to employ a small, flat in place or a large, cumbersome one. The Yale lock consists essentially of a cylindrical plug placed in an outer barrel.

The plug is rotated by a key and in-turn moves the bolt of the lock by means of a cam. In order to rotate the plug, the inserted key must raise five pins of different sizes into a corresponding hole in the plug. Five similar pins are contained in the upper part of each of the holes, if the pins are not raised to the circumference of the plug, the plug cannot be turned.

In 1862, Yale Jr. introduced the monitor bank lock making the transition in bank lock from key lock to combination lock. The principle embodied in his monitor lock is now standard in combination lock through the United States of American (USA) and the world at large.

Of the various locks that are not operated by keys, the dial or combination lock is the most common. A set of tumblers or wheels, is attracted by a spindle that can be rotated by a graduated dial on the outer end of the lock. Spinning the dial according to the proper combination arranges the tumblers so that the bolting mechanism is released. Combination locks of intricate designs, incorporating various electronic safeguards, are produced for safes and bank vaults, and can have more than 100 million changes of combination.

The search of a perfect lock still persists and there are many types of lock that are in existence in our world today of which the main types and their functions are listed below:

(a) Mechanical key locks

(b) Magnetic locks

(c) Electronic locks

(a) **MECHANICAL KEY LOCKS:** These are locks that consist of bolt that may be slid to and fro or rotated by the key (e.g. padlock).

In this type of lock, there are obstacles called wards or tumblers that permit only the right key to be turned on. This is mostly applicable in doors, gates and windows of houses, stores etc. A key and its hole on the lock shown in fig 2.1

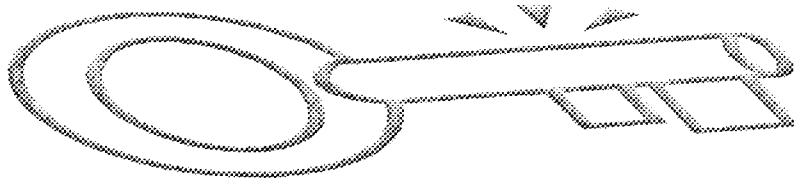

(a) Key

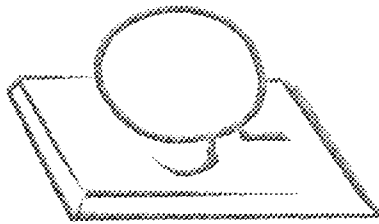

(b) Key hole

Fig 2.1 DIAGRAM OF A MECHANICAL LOCK

(b) **MAGNETIC LOCK:** These are locks that are operated based on the theory of magnetism. These types of locks consist of bolts connected to magnets to ensure that they are locked. The key (which is usually a ferrous metal foil) when inserted pulls the bolts there by releasing the lock to ensure it is opened (e.g. solenoid). It is mainly used in residential as well as administrative areas (e.g. offices).

These mechanisms are illustrated in fig 2.2

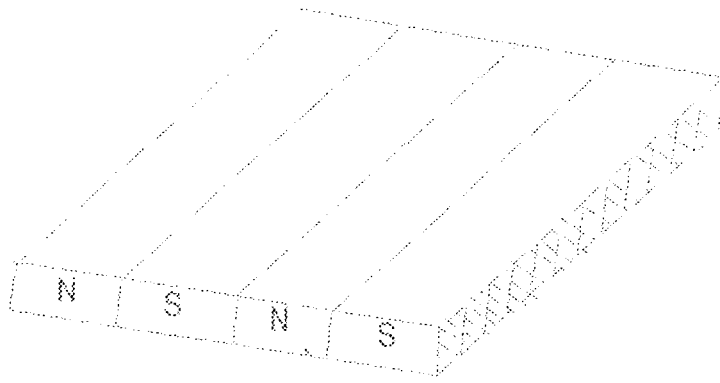

(a) Magnetic Lock

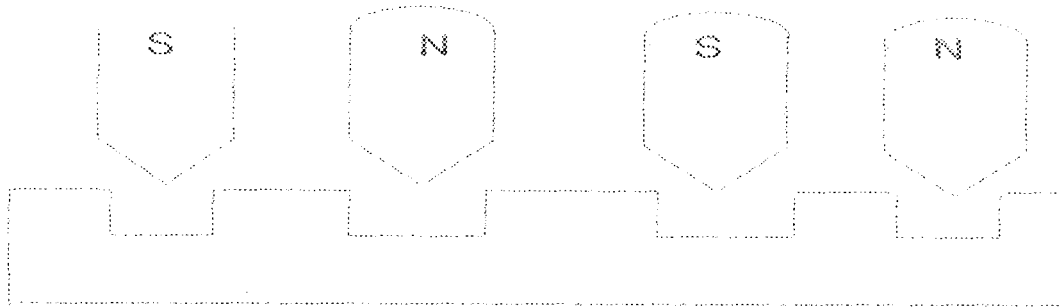

(b) Locking mechanism

Fig 2.2 DIAGRAM OF A MAGNETIC LOCK

(c) **ELECTRONIC LOCKS:** These are the most sophisticated of all the locks. This is because unlike the two other types that require a sort of key to open them, this doesn't require a key so that the issues of keys getting missing does not come into play. These types of locks are driven basically by electronic means and they are used mostly in industrial areas where high level of security is needed. Of electronic locks, some are described below:

i. **DNA Sensor Locks:** These are sophisticated electronic locks that compute into their memories; the gene make-up of the individuals that have their DNA computed into its memory would be allowed to enter. This is used in foreign countries in places like the pentagon where a high level of security is needed.

ii. **Card Sensor Locks:** These are electronic locks that use cards or keys such that when the card is inserted, it generates voltage by closing the circuit and energizing the relay which then opens the lock. These are used in industrial areas. This is shown in fig 2.3 below:

CHAPTER THREE

3.0 DESIGN AND IMPLEMENTATION

3.1 INTRODUCTION

Engineering design is the creative process of identifying needs and then devising a product to fulfill those needs. In other words, Engineering infrastructures and systems arise out of perceived needs. They usually have a feedback influence on society, which brings about profound changes in the society's way of life. This project is designed as a result of such perceived need. The need for more reliable solution to insecurity of private and public property. The design which is hardware and software based, involves the analysis, the calculations and considerations that led to the choice of components for each unit. It brings together the components that make up the system. The figure below shows the block diagram of the different units that make up the system.

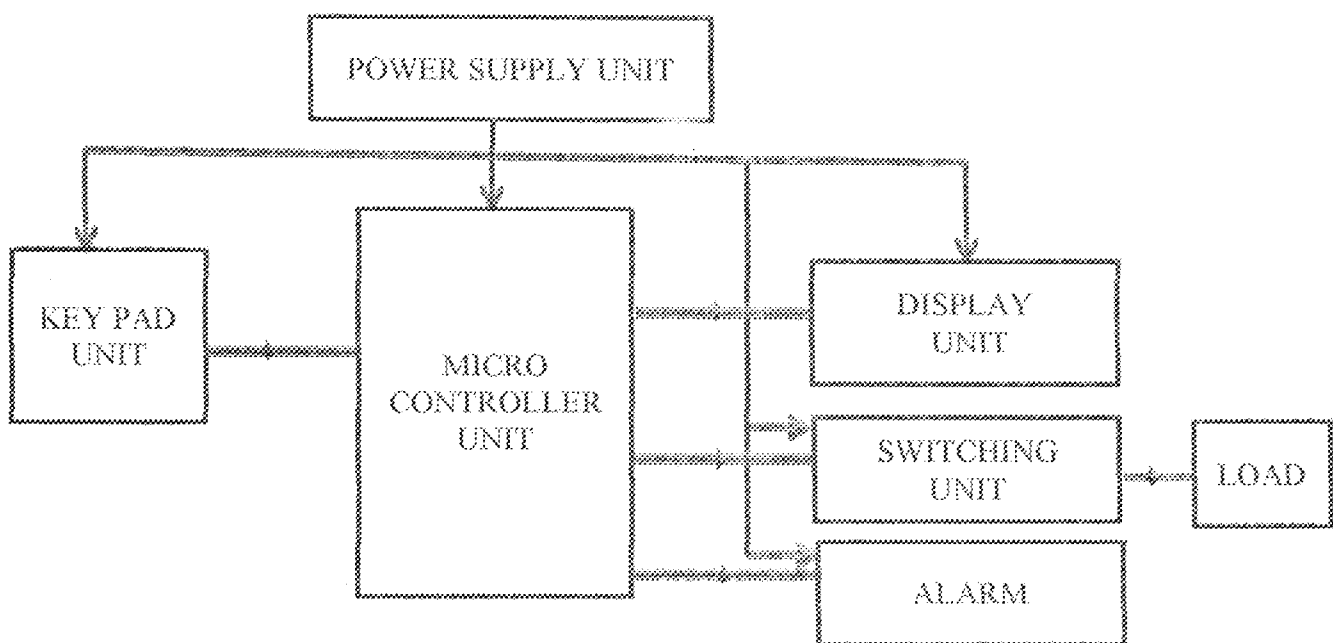

Figure 3.1 block diagram of a microcontroller-based digital lock.

3.2.1 THE TRANSFORMER

The first stage of the power supply design involves the stepping down of the 220V ac from the mains to about 12V ac with the aid of 220V/24V transformer, whose current capacity is enough to drive the entire circuit.

The transformer is an electrical device that provides physical isolation between the 220V ac mains and the rest of the hardware. The only link is by means of magnetic flux. It consists of two coils, the primary (input) winding and the secondary (output) winding. Figure 3.3 shows the circuit symbol of a transformer. The ratio of the primary voltage V_1 to the secondary voltage V_2 is equal to the ratio of the number of turns in primary winding n_1 to that in the secondary winding n_2 ;

$$\frac{V_1}{V_2} = \frac{n_1}{n_2} \quad (3.1)$$

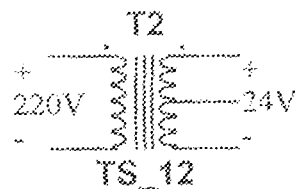

Fig 3.3 Transformer circuit symbol.

3.2.2 THE RECTIFIER

The rectifier converts the 24v ac voltage from the transformer into a pulsating dc voltage and this process is called rectification.

A full – wave rectifier is used for the rectification, it consist of two IN4007 diode in the arrangement shown in fig 3.4 below.

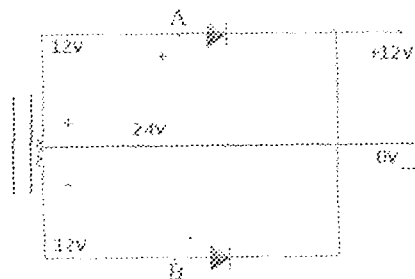

Fig 3.4

The AT89C52 is a low-power, high performance CMOS 8-bit microcomputer with 4K bytes of flash programmable and erasable read only memory (PEROM). The device is manufactured using Anrit's high-density non-volatile memory technology and is compatible with the industry standard MCS-52 instruction set and pinout. The on-chip flash allows the program memory to be re-programmed in-system or by a conventional non-volatile memory programmer. By combining a versatile 8-bit CPU with flash on a monolithic chip, the Anrit AT 89C52 is a powerful microcomputer which provides a highly flexible and cost effective solution to many embedded control applications.

3.2.6 AT89C52 MICROCONTROLLER

In this design AT89C52 MICROCONTROLLER was used. A microcontroller has a *dedicated input device* and often (but not always) has a small LED or LCD display for output. A microcontroller also takes input from the device it is controlling and controls the device by sending signals to different components in the device. A microcontroller might consume 50 milliwatt.

Microcontrollers are often *low-power devices*. A desktop computer is almost always plugged into a wall socket and might consume 50watts of electricity. A battery-operated microcontroller are *dedicated to one task* and run one specific program. The program is stored in ROM (read-only memory) and generally does not change. Microcontrollers are *embedded* into a product. Another name for a microcontroller, therefore, is "embedded controller".

Microcontrollers are "special purpose computers". Microcontrollers are "EMBEDDED" inside some other device (often a consumer product) so that they can control the features or action of the product. Another name for a microcontroller, therefore, is "embedded controller".

3.2.5 CONTROL UNIT

The 7805 regulator used in this project is to regulate a voltage of 12V to a value of 5volts to power all units except the relay.

The AT89C52 provides the following standard features: 4k bytes of flash, 128bytes of RAM, 32 I/O lines, two 16-bit timer/counters, and five vector two-level interrupt architecture, a full duplex serial port, on chip oscillator and clock circuitry. In addition, the AT89C52 is the design with static logic for operation down to zero frequency and supports two software selectable power saving modes. The Idle mode stops the CPU while allowing the RAM, timer/counters, serial port and interrupt system to continue functioning. The Power Down Mode saves the RAM content but freezes the oscillator disabling all other chip functions until the next hardware reset.

3.2.7 SWITCHING UNIT

The switching unit enables the microcontroller to switch from the main to alternative source of power and back. It consists of the following:

- Relay
- Diode
- Resistor
- Transistor

RELAY

A relay is an electrically operated switch, and it uses an electromagnet OR it is an electrical switch that opens and closes under the control of another electrical circuit. It was invented by Joseph Henry in 1853, because a relay is able to control an output circuit of higher power than the input circuit, it may be considered in broad sense to be an amplifier.

RELAY OPERATION

When current flows through the coil, the resulting magnetic field attracts an armature that is mechanically linked to a moving contact. The movement either makes or breaks a connection with a fixed contact. When the current to the coil is switched off, the armature is returned by a force approximately half as strong as magnetic force to its relaxed position. Usually this is a spring, but gravity is also used commonly in industrial motor starters. Most relays are manufactured to operate in a low voltage application, this is to reduce arcing.

The coil of a relay passes a relatively large current, typically 30mA for a 12v relay which is used in this design but it can be as much as 100mA for relay designed to operate from lower voltages. Most ICs (chips) cannot provide this current and a transistor is usually used to amplify the small IC current to the larger value required for the relay coil.

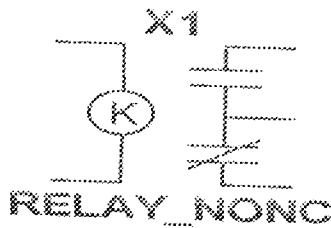

Fig 3.6 Symbol of a relay

RELAY APPLICATIONS

Relays find application in many areas, some of which include:

- To control a high voltage circuit with a low voltage signal, as in some types of modems.
- To control a high current with low current signal, as in the starter solenoid of an automobile.
- To detect and isolate faults on transmission and distribution lines by opening and closing circuit breakers (protection relays).
- To isolate the controlling circuit from the controlled circuit when the two are at different potentials, for example when controlling a mains powered device from a low voltage switch. The latter is often applied to control office lighting as the low voltage wires are easily installed in partitions, which may be often moved as needs change. They may also be controlled by room occupancy detectors in an effort to conserve energy.

3.2.8 DIODES

Diodes are devices that allows electricity to flow in one direction only. The arrow of the circuit symbol shows the direction in which current can flow. Diodes are the electrical version of a valve and early diodes were actually called valves. There is a small voltage drop across a conducting diode, it is called forward voltage drop and is about 0.7V for all normal diodes which are made from silicon. The forward voltage drop of a diode is almost constant whenever current is passing through diode so they have a very steep characteristic as shown in the current –voltage graph below.

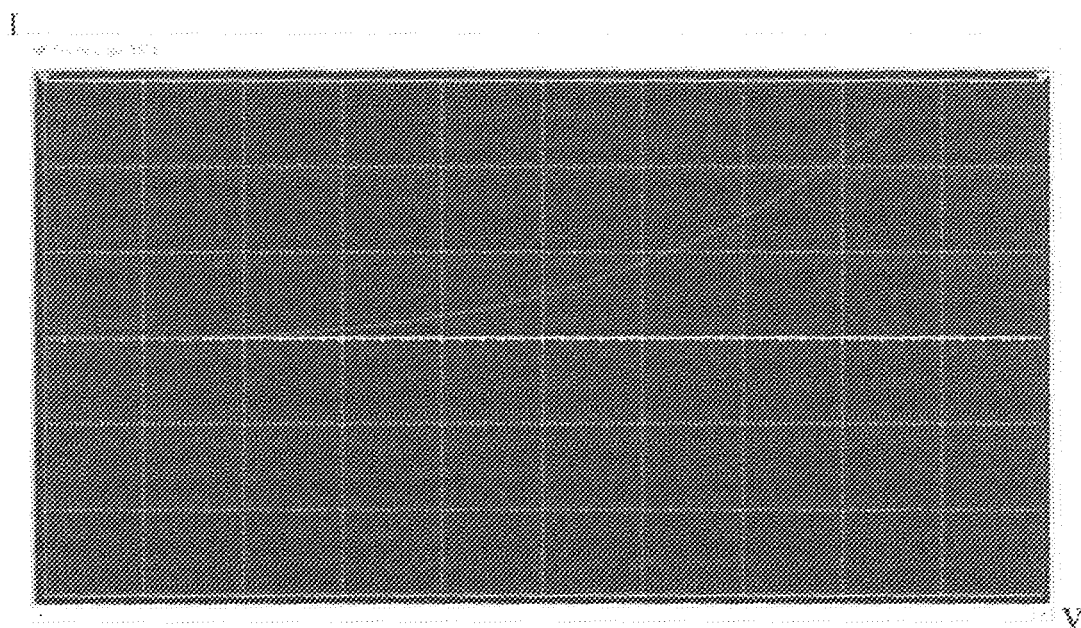

Fig 3.7 characteristic diagram of a silicon diode

When a reverse voltage is applied a perfect diode does not conduct, but all real diodes leak a very tiny current of a few μA or less. This can be ignored in most circuits because it will be very much smaller than the current flowing in the forward direction. However all diodes do have a maximum reverse voltage (usually 50v or more) and if this is exceeded. The diode will fail and pass a large current in the reverse direction, this is called break down.

Ordinary diodes can be split into two types: signal diodes which pass small currents of 100mA or less and Rectifier diode which can pass large current. Diode must be connected the

correct way round, the diagram may be labeled 'a' or +ve for anode and 'k' or -ve for cathode. The cathode is marked by a line painted on the body. Small signal diodes can be damaged by heat when soldering, but the risk is small unless a germanium diode is being used in which case a heat sink should be clipped to the lead between the joint and the diode body. A standard crocodile clip can be used as a heat sink.

Signal diodes are used to process electrical signals in circuits, so they are only required to pass small current of up to 100mA. General purpose signal diodes such as the IN4007 are made from silicon and have a forward voltage drop of 0.7v while Germanium diodes such as 0A90 have a level forward voltage of 0.2v and this makes them suitable to use in radio circuits as detectors which extract the audio signal from the weak radio signal.

For general use, where the size of the forward voltage drop is less important, silicon diodes are better because they are less easily damaged by heat when soldering. They have a lower resistance, when conducting, and they have very low leakage currents, when a reverse voltage is applied. Signal diodes are also used to protect transistors ICs from the brief high voltage produced when a relay coil is switched off, as incorporate in this design.

Rectifier, diodes are used in power supplies to convert alternating (AC) to direct current (DC), a problem called rectification. They are also used in circuits where a large current must pass through the diode. All rectifier diodes are made from silicon and therefore have a forward voltage drop of 0.7v. The IN4001 is suitable for most low voltage circuits with a current of less than 1A.

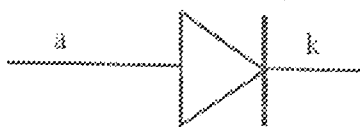

Fig 3.8 symbol of Diode

3.3 TRANSISTORS

There are two types of standard transistors, NPN and PNP with different circuit symbols. The letters refer to the layers of semiconductor material used to make the transistor. Most transistors used today are NPN because, this is the easiest type to make from silicon. NPN is one of the two types of bipolar transistors, in which the letter 'N' (negative) and 'P' (positive) refer to the majority charge carriers inside the different regions of the transistor. In NPN transistors which are used in this design, electron mobility is higher than hole in semiconductors, allowing greater current and faster operation. NPN transistors consist of a layer of P-doped semiconductor (the "base") between two N-doped layers. A small current entering the base in common-emitter mode is amplified in the collector output. In other terms, an NPN transistor is "on" when its base is pulled high relative to the emitter. PNP transistors consist of a layer of N-doped semiconductor between two layers of P-doped material. A small current leaving the base in common emitter-mode is amplified in the collector output. In other terms, a PNP transistor is "ON" when its base is pulled low relative to the emitter.

The arrow in the PNP transistor symbol is on the emitter leg and points in the direction of the conventional current flow when the device is in forward active mode.



Fig 3.9.0 (a) symbol of an NPN

(b) symbol of a PNP transistor

3.3.1 DISPLAY UNIT

The most commonly used character based LCDs are based on Hitachi's HD44780 controller or other which are compatible with HD44580. Liquid crystal display (LCD) device desired for interfacing with embedded systems. These screens come in common configurations of

8x1 characters, 16x2, and 20x4 among others. The largest such configuration is 40x4 characters, but these are rare and are actually two separate 20x4 screens seamlessly joined together. Character LCD can come with or without backlights. Backlight can be LED, fluorescent or electroluminescent.

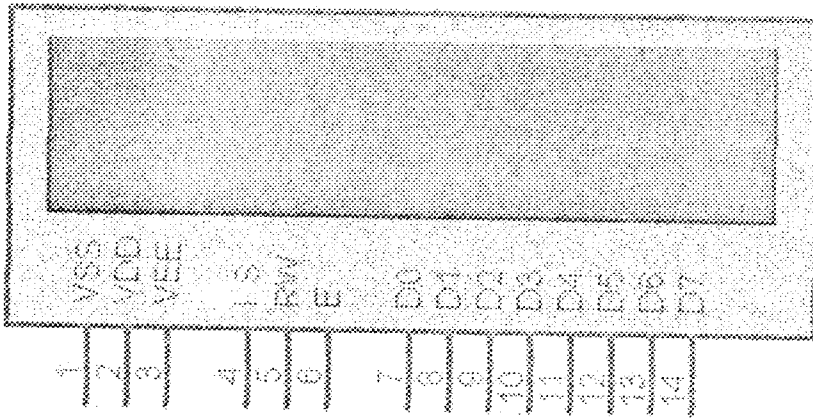

Fig 3.10 (Diagram of LCD)

3.3.2 PIN DESCRIPTION

The most commonly used LCDs found in the market today are 1 line, 2 line, or 4 line controller and support at most 80 characters, whereas LCDs supporting more than 80 characters make use of 2HD44780 controllers.

Most LCDs with 1 controller have 14pins and LCDs with 2 controllers have 16pins (two pins are extra in both for back-light LED connections).

3.4 DESIGN OF POWER SUPPLY UNIT

Most electronic devices and circuits require a DC source for their power operation, and a typical dc power supply consists of five components which include transformer, rectifier, filter, voltage regulation and load. The complete circuit diagram of power supply unit is as shown below.

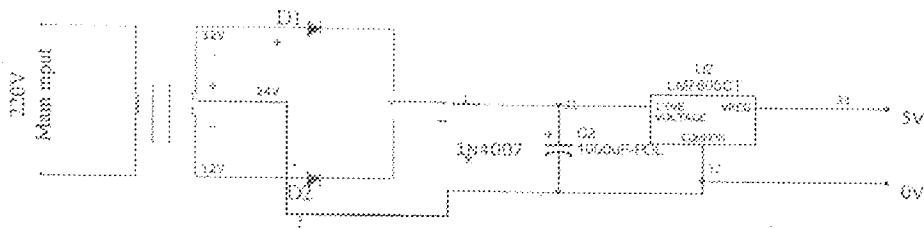

Fig 3.11

The main voltage of 220V is stepped down by a 220V/24V transformer; it is then rectified by the use of a full-wave rectifier using two IN4007 diode. It is then filtered by the use of an electrolytic capacitor of value $1000\mu F \times 35v$. The ripple free DC voltage is regulated using a 7805 regulator, to give a steady DC output voltage of 5v.

3.4.1 RECTIFIER SELECTED FOR CIRCUIT

By definition as earlier stated, a rectifier is a circuit which employs one or more diodes to convert ac voltage into pulsating dc voltage. The step down transformer provides an r.m.s voltage of 12v, so peak value can be determined using the elementary calculations.

$$V_{r.m.s} = \frac{V_{peak}}{\sqrt{2}} \dots\dots\dots (i)$$

$$V_{peak} = V_{r.m.s} \times \sqrt{2} \dots\dots\dots (ii)$$

$$V_{peak} = 12v \times \sqrt{2} = 16.9v \cong 17v$$

The average DC value of full wave signal

$$V_{peak} = \frac{1}{2} V_{dc} \dots\dots\dots (iii)$$

$$V_{dc} = \frac{2V_{peak}}{\pi} \dots\dots\dots (iv)$$

$$\pi = 3.142$$

$$V_{dc} = \frac{2 \times 16.9}{\pi} = \frac{33.8}{3.142} = 10.75 \cong 11v$$

For full wave rectification, peak inverse voltage (PIV) should be equal to or greater than the maximum output peak voltage.

$$PIV \geq 2V_{peak}$$

$$PIV \geq 2 \times 17$$

$$PIV \geq 35v$$

Diode IN4007 is selected which has a PIV of 200V

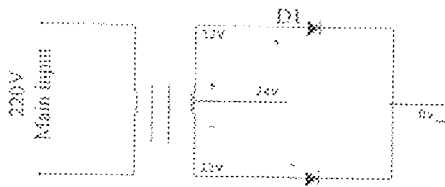

Fig 3.12

RECTIFIER UNIT

3.4.2 CAPACITANCE OR FILTER SELECTION

The peak voltage, $V_{peak} = V_{r.m.s.}(2)^{\frac{1}{2}}$

$$12 \times (2)^{\frac{1}{2}} = 16.9 \cong 17v$$

But,

$$Q = It = CV \dots\dots\dots (v)$$

and AC mains frequency is 50HZ so therefore;

The frequency of the rectifier output voltage is twice the supply frequency. Therefore, output frequency of full wave rectifier

$$= 2 \times \text{input frequency from ac mains} \dots\dots\dots (vi)$$

$$F_{out} = 2 \times 50\text{HZ}$$

$$= 100\text{HZ}$$

$$\text{therefore, } t = \frac{1}{100} = 0.01$$

$$C = It$$

Where I_{dc} is specified by the transformer

Input dc current (I_{dc}) = 500mA

Knowledge has it that Δv is usually about 30% of peak voltage

(V_{peak}); $\Delta v = 30\%$ of V_{peak}

$$= \left(\frac{30}{100}\right) \times 17 = 5.1 \text{volts}$$

Filter capacitance;

$$C = \frac{I_{dc}}{f_{out} \times \Delta V_{ripple}} \dots \dots \dots (vii)$$

$$= \frac{500 \times 10^{-3}}{100 \times 5.1}$$

$$= \frac{500 \times 10^{-3}}{510}$$

$$= 980 \mu F$$

The more the capacitance, the better its filtering effect, this a capacitor of the available $1000 \mu F$ is used.

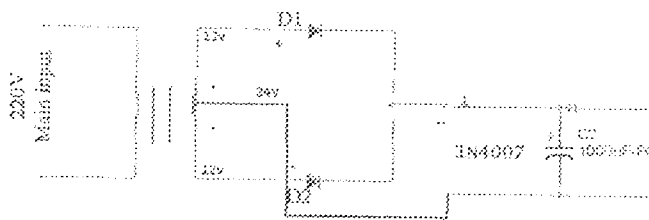

Fig 3.13

FILTERING UNIT

3.4.3 REGULATOR SELECTION LM7805

When discussing the issue of voltage regulation, it means the measure of the circuit ability to maintain a constant output voltage whenever input voltage or load current varies. The instantaneous voltage at the input of IC regulator must always exceed the d.c output voltage by a value that is typically up to 0.5v to 3v.

Input voltage: 8-35v

Output voltage: 5v

Current change: 0.5 – 1.3mA

These values were chosen in order to provide 5v dc supply required to power every unit of the design except the relay.

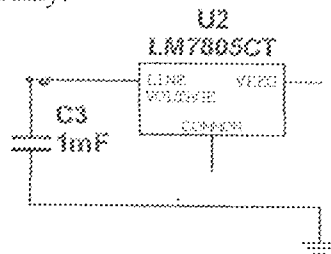

Fig 3.14 Voltage Regulation Unit

3.4.4 THE CONTROL UNIT

The AT89C52 microcontroller is the main control unit, it processes and verifies the keypad inputs (Enter lock code), and generates control signal to power the lock mechanism. Thus, this is done by comparing the digits with the right PIN or lock code number in the EEPROM memory (internal).

If it is correct, the LCD displays "lock inactive" meaning, access can now be granted. Else, after three tries, it prompts the users with a text display "lock code blocked" meaning access denied and also with a buzzer.

It will be advisable to know that the microcontroller can work only if some few components are incorporated on the controller. These include:

- (a) Crystal oscillator, which serves as a clock to the microcontroller. This also can be considered as the frequency controller unit. The speed of execution of each task is enhanced using a frequency of 12 MHz. The instruction cycle of the microcontroller divides this frequency by four(4)

$$F_{Instruction} = \frac{F_{oscillator}}{4} \dots\dots\dots (viii)$$

$$= \frac{12MHz}{4} = 3MHz$$

the instruction period is therefore;

$$\frac{1}{F_{Instruction}} = \frac{1}{3MHz}$$

$$= 0.3\mu s$$

- (b) The Enable pin has to be connected to V_{cc} to enable the chip access program memory

- (c) The reset capacitor, this resets the microcontroller and sets the program counter to the beginning of the program.

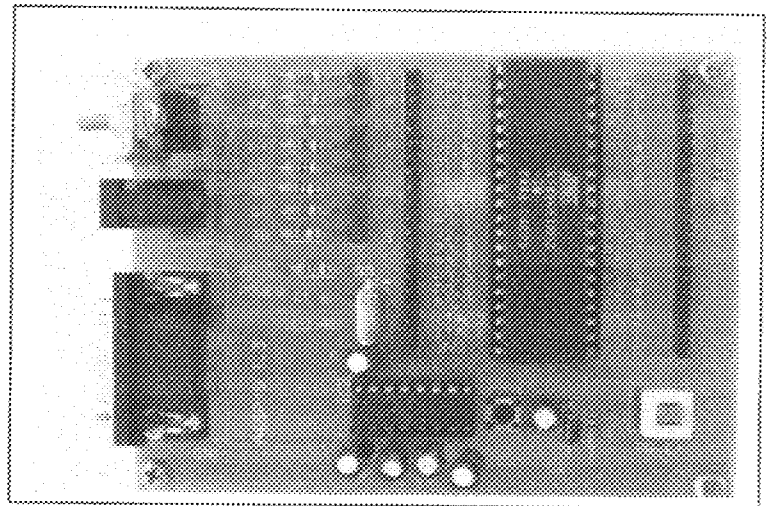
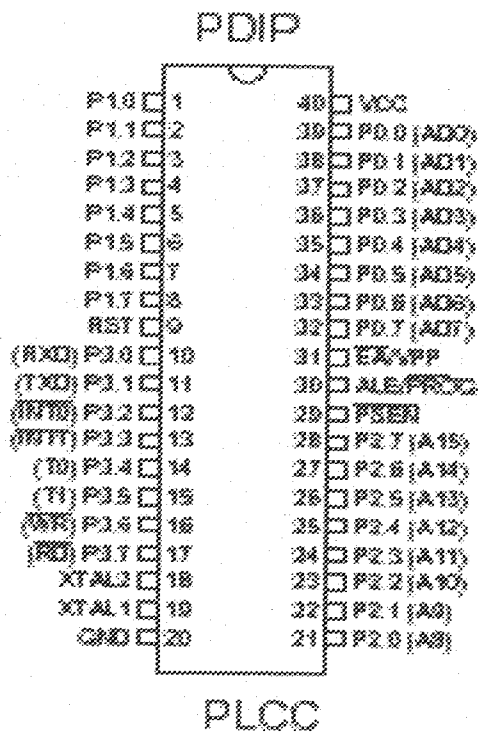

Fig 3.16 Diagram of AT89C52 Microcontroller

Fig 3.15 Pin description of AT89C52 microcontroller

3.4.5 DESIGN PIN DESCRIPTION OF THE CONTROL UNIT

Pin 1-8 (port 1) – this is where the keypad is connected

Pin 10-17 (port 3)- Only the alarm is connected here, it is connected to 1bit of the port or port3.

Pin 21-28 (port 2) This is where the LCD is connected

Pin 32-39 (port 0) – not in use.

3.5 DESIGN OF THE SWITCHING UNIT

The output from the regulator is used to power every unit of the design except the relay. The relay used is 12v, the coil of the relay passes relatively large current, typically 30mA for a 12v relay, but it can be as much as 100mA for relay designed to operate from lower voltages.

A switching transistor is connected to the relay to isolate the DC part from the AC part and a biasing resistor ($1k\Omega$) connected to the base of the transistor, to allow successful amplification. The diode D5 protects the transistor whenever the relay is energized and also allows the reverse current flow instead of flowing through the transistor. The switching transistor used is 2N3904, it has a collector-emitter voltage of 40V, collector base voltage of 60V, emitter base voltage of 60V it can withstand a continuous collector current of about 250mA and can operate between temperatures -55°C and 150°C .

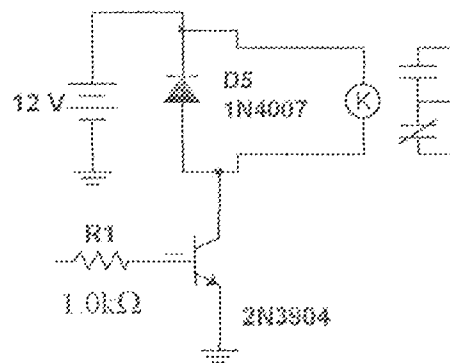

Fig 3.17 CIRCUIT DIAGRAM OF THE SWITCHING UNIT

In biasing the transistor, a base resistor was used as earlier mentioned, so therefore, the calculations required for achieving my resistor rating is given below.

$$V_{CC} = 5\text{v}$$

Where R_c = relay resistance which is 100Ω .

$$I_c = \frac{V_{CC}}{R_c} = \frac{5}{100}$$

$$= 0.05\text{A}$$

$$= 50\text{mA}$$

But $h_{FE} = 12$, for 2N3904 transistor.

$$\therefore 12 = \frac{I_c}{I_b}$$

$$\text{Therefore } I_b = \frac{0.05}{12} = 0.004\text{A}$$

As designed, the output from AT89C52 microcontroller at the ports which act as input to the base of the transistor is 3.6v.

$$\text{Therefore } V_b = V_{\text{output}} = I_b R_b = 3.6\text{v}$$

$$I_b = 0.004$$

$$V_{\text{output}} = 0.004 \times R_b$$

$$3.6\text{v} = 0.004 \times R_b$$

$$R_b = \frac{3.6\text{v}}{0.004} = 900\Omega$$

$$R_b \cong 1000\Omega = 1\text{k}\Omega$$

The resistor used is 1k Ω

3.5.1 DESIGN OF THE DISPLAY UNIT

A 16 character by 2 line liquid crystal display (LCD) was interfaced with the microcontroller, connected to the LCD was a variable resistor of 50 k Ω which is used to adjust the contrast of the LCD and a resistor connected to the LED of the LCD, it serves as a current limiter to the LED or back light of the LCD.

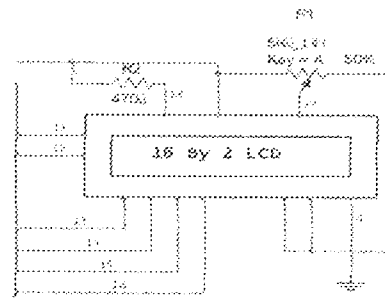

Fig 3.18 Circuit diagram of display unit

LCD PIN DESCRIPTION

Pin 1-ground

Pin 2- V_{cc}

Pin 3-input to contrast (variable resistor)

Pin 4-Register select

Pin 5-Read/Write

Pin 6-Enable

Pin 7-14 parallel 8bits data lines

3.5.2 DESIGN OF THE KEYPAD UNIT

The keypad is employed as an external interface to the system through which a user can communicate with the microcontroller to perform already programmed function. In this project a 4×3 matrix keypad was employed as shown below.

The keypad contains numeric keys which are designed to input numeric values into the system, they include "0-9" while the "#" is used to process the inputs. In the design of the keypad, there is a need for mandatory processing unit to decipher an authentic key pressed from an unwanted noise pulse. This is known as key debouncing, to prevent against multiple single inputs, a debounced delay of 150ms was chosen as a start value in the program written, this provided an advantage of reduced hardware and flexible debouncing period.

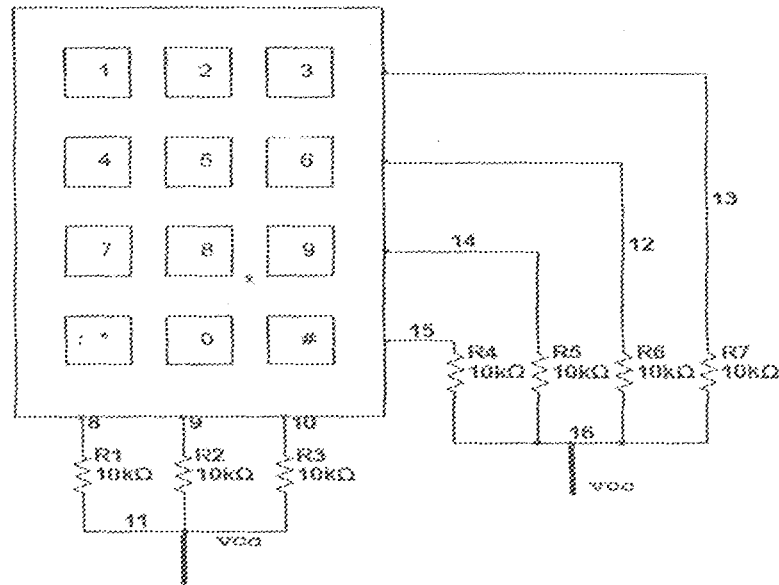

Fig 3.19 Circuit diagram of keypad unit

From, the above keypad circuit diagram, resistors called pull up resistors were connected to rows and columns of the 4× 3 matrix keypad.

These resistors are 10kΩ each and their function is to limit the current flowing into the microcontroller from going beyond the maximum sinking current or source current.

From Ohm's law

$$V = IR$$

$$V = 5V, R = 10 \text{ k}\Omega, I = ?$$

$$\therefore I = \frac{V}{R} = \frac{5}{10\text{k}\Omega} = \frac{5}{10,000} = 0.0005A$$

$$I = 0.0005A$$

Therefore, the current is less than the maximum sinking current the microcontroller can take.

3.6 THE PIC PROGRAMMER

Programming the microcontroller requires a special hardware called PIC programmer. It is a device that connects the PC via either serial, parallel or USB port. With the microcontroller chip placed into the socket on the device, a special software known as Assembler helps transfer the program from PC to the PIC programmer which in turn "Burns" the program into the circuit, to perform its function.

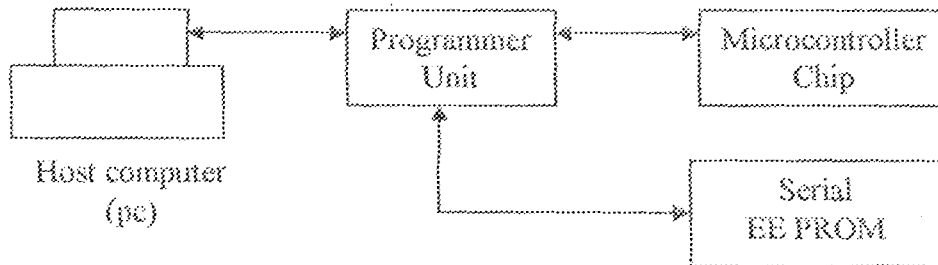

Fig 3.20 Schematic diagram of programming the Control unit.

3.6.1 ALARM

The buzzer alarm is included in the circuit to come on when wrong pin is inputted three times, so as to alert against intruders. When wrong pins are inputted as programmed, the microcontroller activates the port to which the buzzer is connected (port 3).

3.6.2 SOFTWARE DESIGN

The software is designed in order to support the effectiveness of the hardware device. The complex and intricate operating routine of the software is achieved by writing the program in modules, starting with the program algorithm, followed by the program flow chart. The software was written in assembly language and was written in sections for easy debugging and troubleshooting. Each section is tailored to meet the duty that will be imposed on the corresponding hardware unit.

3.6.3 DISPLAY PROGRAM

The display unit (LCD) displays different texts based on the operating state of the device, some of the status displayed are "A digital lock by the name and matriculation number of the designer", "enter lock code", "enter master code", "enter new code", "verify new code", "device active", "device inactive" etc.

3.6.4 KEYPAD PROGRAM

Apart from the keypad coordinating the activities of the microcontroller, another major programming done here is preventing jumping of the input key (bouncing) as earlier explained in the keypad unit.

3.7 DESIGN FLOW CHART

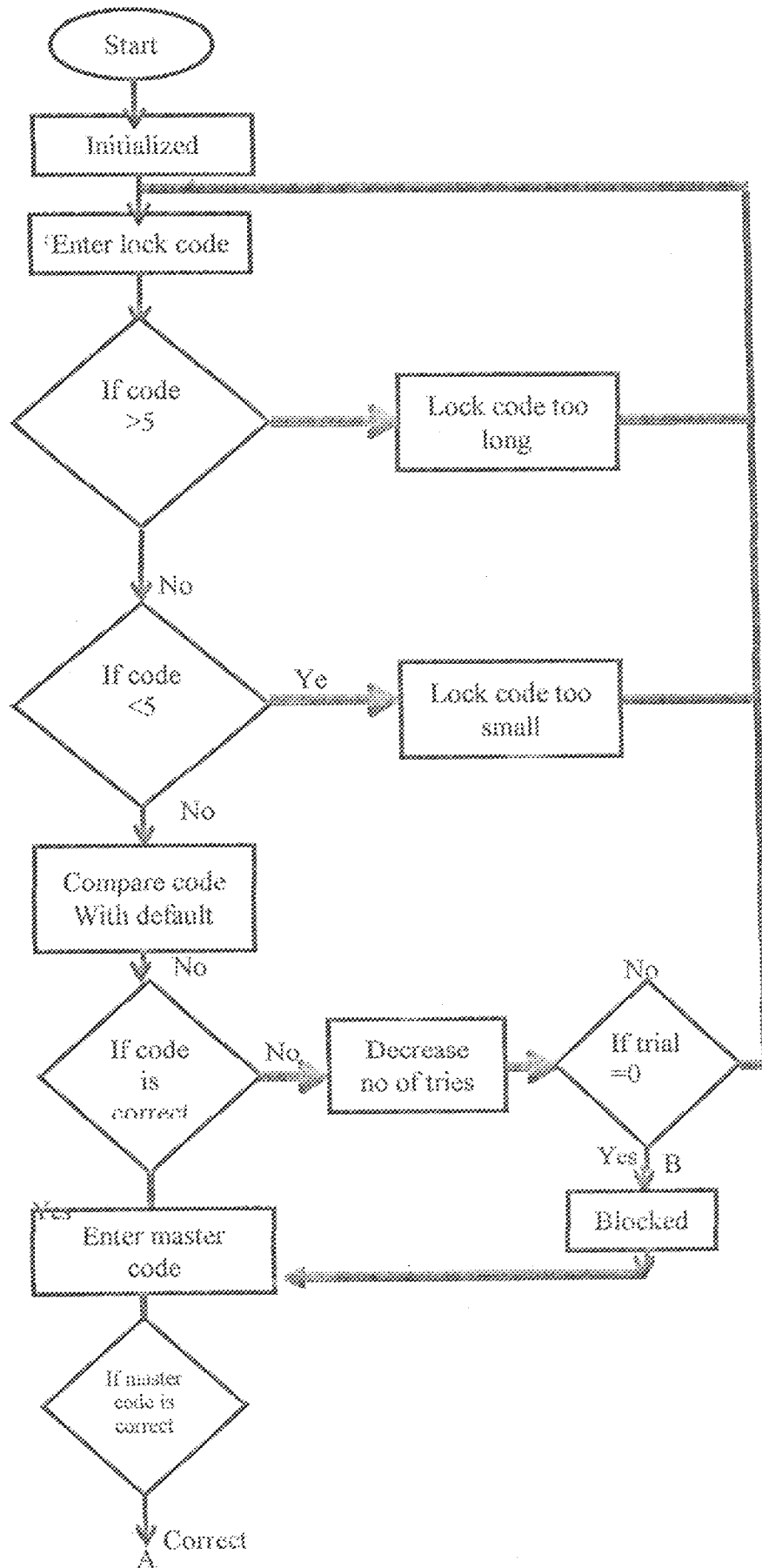

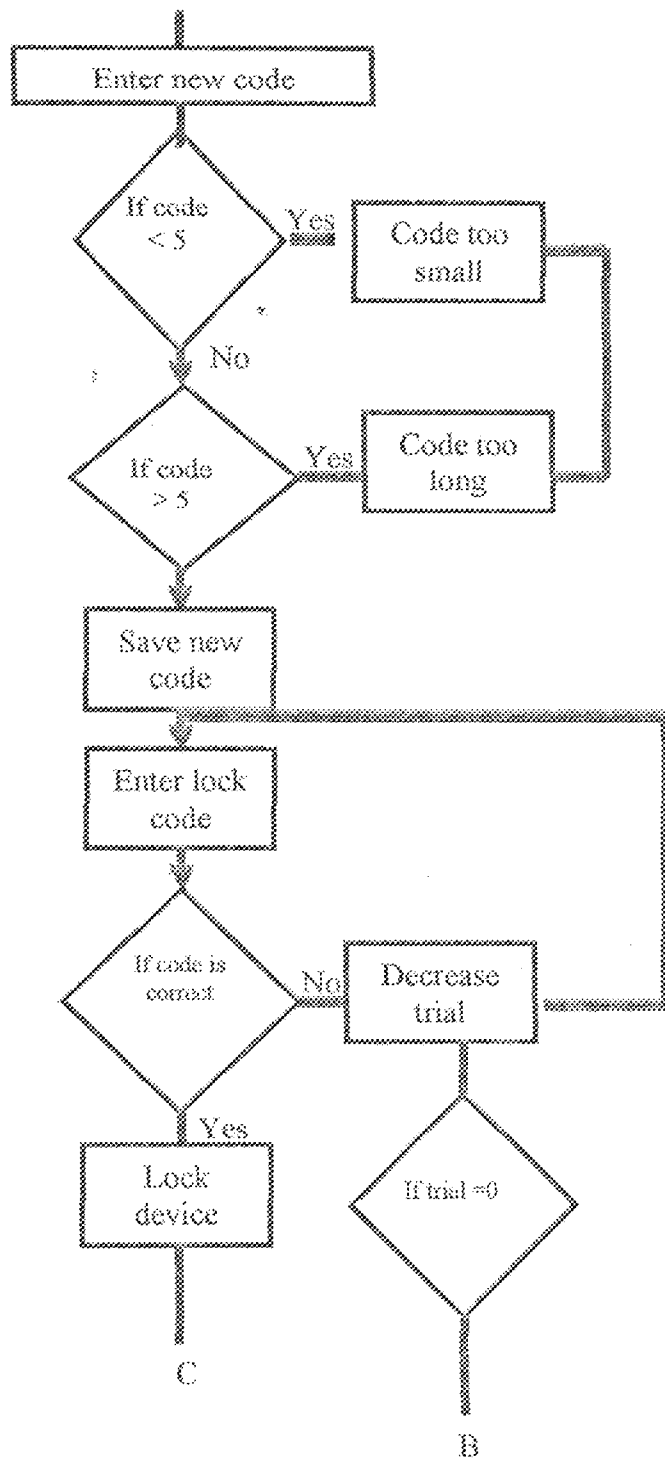
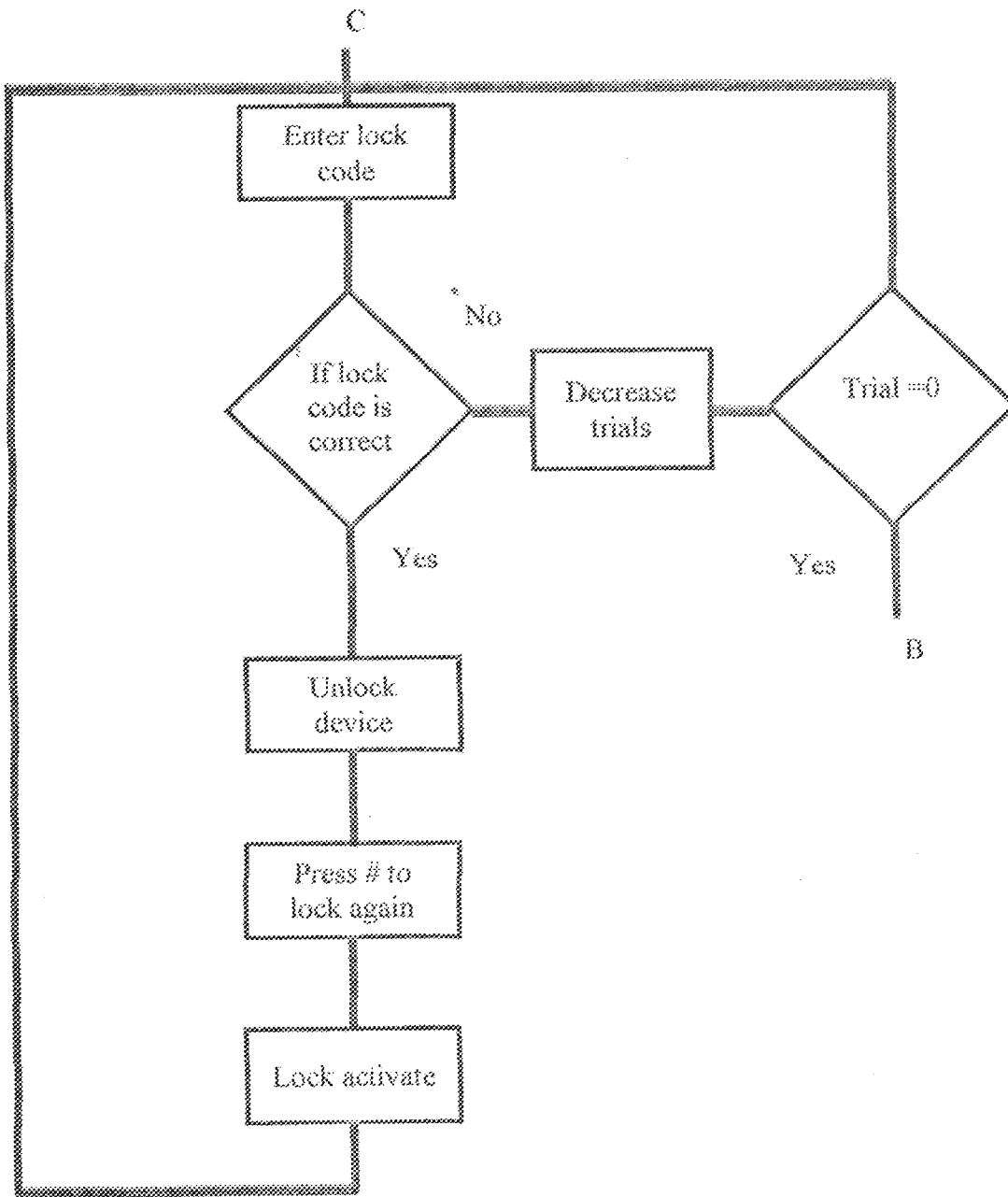
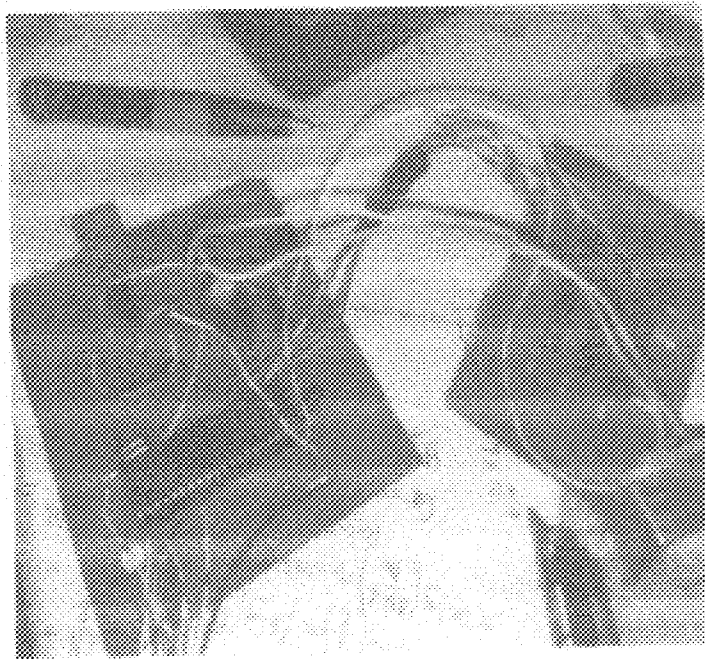
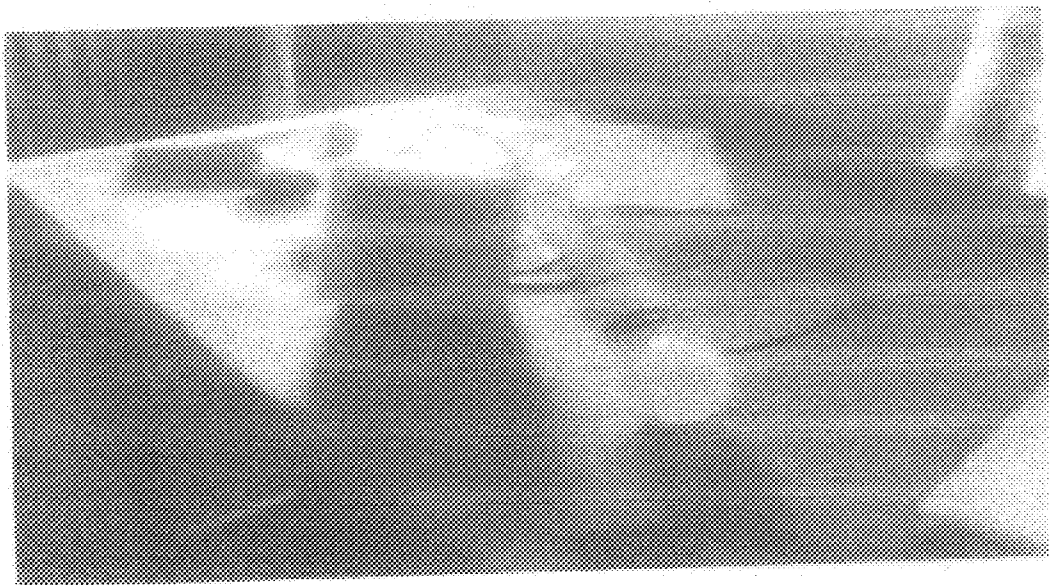

Fig 3.21





Internal circuitry



Complete casing of the construction

3.8 COMPLETE DESIGN CIRCUIT DIAGRAM

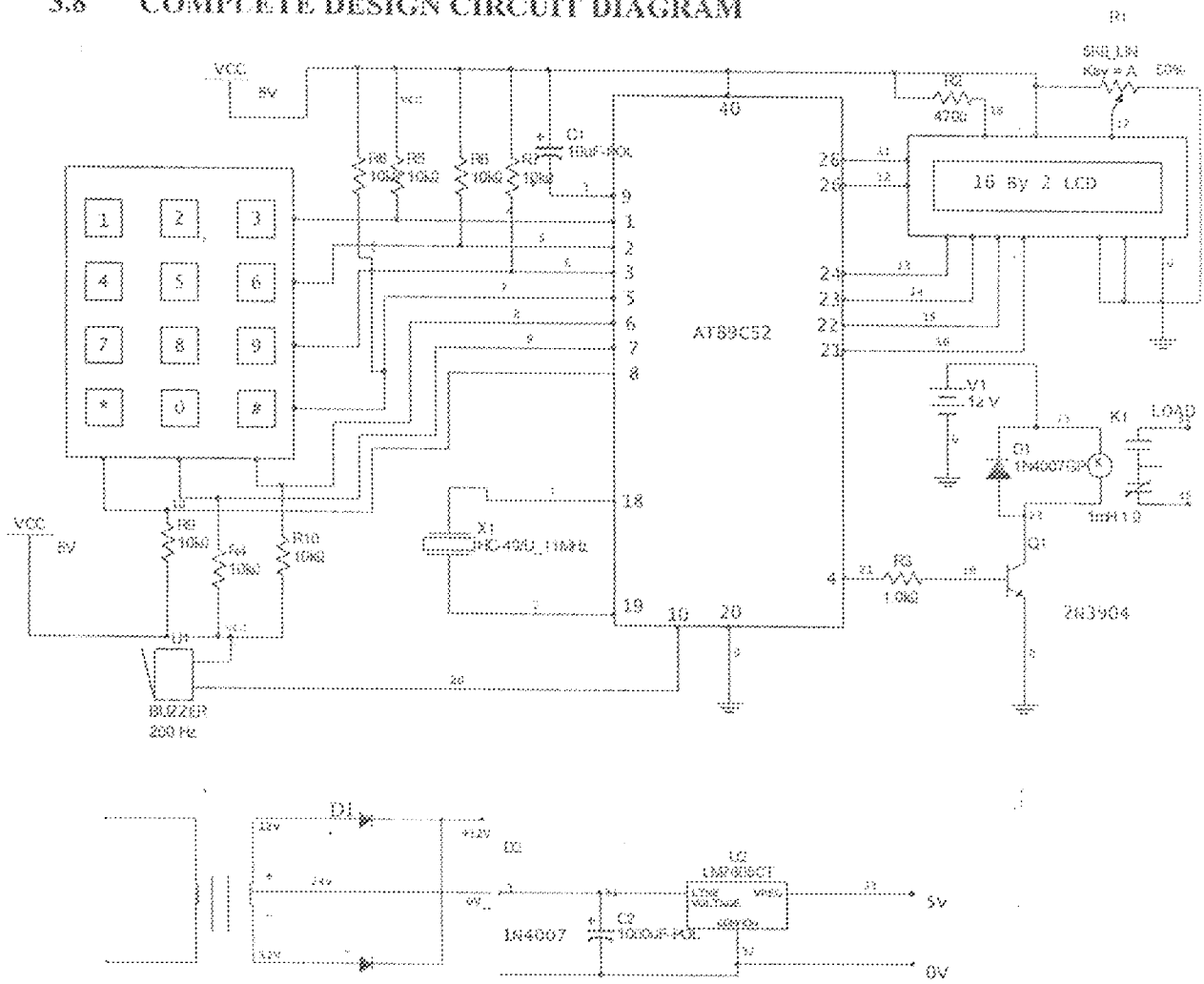

Fig 3.22

CHAPTER FOUR

4.0 CONSTRUCTION, TESTING AND RESULTS

After designing, calculating and selecting the value of components required for effective operation of the project, the circuit was then constructed. The components were carefully mounted on a bread board before being transferred to their specific locations on a Vero board. IC sockets were used to prevent direct heat during soldering; this also made easy replacement in cases of damage. All necessary connections were made according to the design specification with reference to data sheets for appropriate pin connections.

The tools and materials used during the construction of the project are briefly described below.

1. Breadboard- This is a board on which the circuit was set up temporarily to ascertain that it was working before it was transferred to a Vero board.
2. Vero board- This is a perforated plastic, overlaid with stripes of metal conductors. It was used for permanent construction of the project prototype.
3. Lead- This is a metal with low melting point. It was used to hold components and connecting wires in place on the Vero board.
4. Soldering iron- it provided the heat needed to melt the lead onto the Vero board when connected to ac mains.
5. Lead sucker- This is used to suck-up molten lead from the Vero board when de-soldering a connection.
6. Wires and Connectors- Wires are used during the testing stage of the project on a bread board to connect the components together as well as the different sub-units of the circuit.
7. Digital multi-meter- This is a multi-function electronic measuring instrument employed in the measurement of voltages, resistances, transistor current gain and testing for continuity.

Others are pliers, wire cutters, drilling machine, file, chisel, scissors, hammer and bending machine.

4.1 HARDWARE CONSTRUCTION

Careful planning of the circuit layout and simple wiring minimized errors and made troubleshooting easier. All ICs used in the design were aligned in the same direction for a logical signal flow.

Each unit was soldered independently and tested to ensure that it was working fine. All the units were then inter-connected together as specified in the design.

4.2 CONSTRUCTION PRECAUTIONS

- i. All soldered joints were tested for continuity to avoid open circuits.
- ii. All excessive leads were removed to avoid bridges (short circuits) on the board.
- iii. Polarities of electrolytic capacitors and pin configuration of transistors and ICs were properly checked before soldering.
- iv. ICs were mounted on sockets to prevent them from being over-heated and also for easier troubleshooting.
- v. Excessive heating of the components was avoided so that they do not burn out.

Component	Result
(i) The maximum current the transformer can withstand	500mA
(ii) Voltage into the transformer (AC supply)	205.56V
(iii) Voltage across secondary side of transformer	19.56V
(iv) Voltage drop across diode	0.6V

The result shows the proper working condition of the power supply unit.

4.3 KEYPAD UNIT TESTING

The keypad was tested for continuity by connecting a voltmeter across each button as shown below.

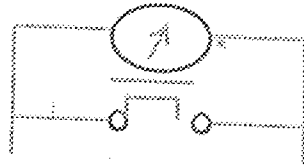

Fig 4. 1 Continuity test of keypad

The continuity test circuit of the meter was selected and the pointer deflected fully to zero reading, in addition to sounding of the meter buzzer, indicating the good condition of the button.

4.4 LCD TESTING

The LCD was tested by connecting the variable resistor between the V_{out} and V_{dd} of the LCD. The following display was obtained as tabulated below.

Value of voltage	Display quantity (contrast)
0.50	No display
1.50	No display
2.00	No display
2.50	Traces of display/blurred screen
2.75	Clear display
3.00	Sharp screen with clear display

Result of testing showed that the LCD worked properly only at the voltage range of 2.75v-3.3v, this was its rated voltage.

4.4.1 TESTING AND RESULT

The written program code was initially tested using application software (edsim51) to make certain that the program gave the desired result. The design components were then laid and

tested on a breadboard to observe the result and ensure that the desired output was obtained after which the components were disconnected from the breadboard.

All current and voltages measurement were taken using a multimeter,

i. The output of the transformer

ii. The rectifier output from the 7805IC (voltage regulator)

iii. The design was tested severally using a 60W incandescent bulb as the load. When connected to the a.c source, the LCD display the following text'' name and the matriculation number of the designer "enter lock code (12345) which is the default pin", enter master code (11234567890,) enter new code (it must not be less than or greater than five digits) etc. it was observed that when the device was active (lock), the bulb was off and when the device was inactive (unlock) the bulb turned on.

4.4.2 PROBLEMS ENCOUNTERED

During the construction phase, there were problems encountered and are listed below:

- i. The difficulty of sourcing for components
- ii. Irregular power supply
- iii. Wastage of resource and time due to damage of components during soldering e.g LCD.
- iv. Due to lack of some components required by the circuit, some modification had to be done in the construction.

CHAPTER FIVE

5.1 CONCLUSION

In summary, the microcontroller based digital lock is a security device that utilizes pin input as key for user's access. It can serve as a device for securing personal wares in vaults, rooms e.t.c against intruders by setting up the alarm for wrong pin input after three trials. This unit use in homes and offices especially banks. The use of the microcontroller chip reduced the size of the device compared to the previous ones that utilized more integrated chips (IC) making them bulky.

5.2 RECOMMENDATION

Improvement can further be carried out on the project in the under listed aspect,

1. The inclusion of backup power supply, through the use of batteries will help buy some time for the user in case of power failure.
2. The use of wireless keypad unit can also reduce the bulkiness of the project.

REFERENCES

- [1] <http://inventors.about.com/library/inventors/bielectric.htm>
 - [2] http://en.wikipedia.org/wiki/electric_power_transmission
 - [3] H.Hayt, Willians, E. Jr. Jack Kemmerly, and Steven M, Durbis "Engineering Circuit Analysis" sixth edition, PP 444
 - [4] J.O Milley, Shaum's outlines, "Basic circuit analysis", 2nd edition, PP153
 - [5] "PIC Micro-mid-range Microcontroller family Reference manual", DS33023A, microchip technology inc, December 1997, PP 8-15, 44
 - [6] Tutorial of Reference for 8052, <http://www.8052.com> PP 27
 - [7] Microcontroller for beginners, www.microelectronicka.com, chapter 2, html.
 - [8] Y.A Adediran, "Applied Electricity", Finon Associates, Mimma Nigeria 1997, P99
 - [9] www.freepatentonline.com/History_locks_and_safe_1577142.html, PP 3-6
 - [10] A.K Theraja and B.L Tberaja, "A textbook of Electrical Technology", 23rd Edition, S Chard and Company Limited, New Delhi, 2002, PP 23-64
- Data sheet information AT89CS2

APPENDIX

```
org 0000h
    setb alarm
    acalled_init
    acallkeypad_initp
    chiskey
    mov sp,#60H
    mov retries,#3
    acallproject_title
    acall delay_1sec
    acall delay_1sec
acall delay_1sec
    call author
    call delay_1sec
    call delay_1sec
    call delay_1sec
    call delay_1sec
    call delay_1sec
main:
    mov a, #LCD_CLR
    acalled_cmd
    mov a, #81h
    acalled_cmd
    movdptr, #str_enter ; Enter lock Code
    acallLCD_sendstring
mov a,#LCD_LN2
    acalled_cmd
    mov a,#LOCK_i ; lock_i = 0
    acalled_data
    mov a,#'
    acalled_data
mov max,#5
    acalliget_input
```

```

    cjne status,#TRUE,main          ; true is 1
    mov dptr,#chk_12345
    mov count,#5
    acallchk
    jnb is_ok,main_2
    acallset_upass
    sjmp main

main_2:
    jb newcode,main_3
    movdptr,#chk_upass
    mov count,#5
    acallehk
    sjmp main_4

main_3:
    acallehk_newcode

main_4:
    jnbis_ok, main_5
    mov retries,#3
    clr lock
    mova,#LCD_CLR
    acalled_cmd
    mov a,#OK_i          ; ok_i = 3
    acalled_data
    movdptr,#inactive
    acallLCD_sendstring
    mov a,#LCD_LN2
    acalled_cmd
    mov dptr,#inactive1
    acallLCD_sendstring
    acall delay_1sec
    mova,#LCD_CLR
    acalled_cmd
    mov a , #S2h
    acalled_cmd

```

```
mov dptr,#inactive2
acallLCD_sendstring
mov a,#LCD_LN2
acalled_cmd
mov dptr,#inactive3
acallLCD_sendstring
acall delay_1sec
acall delay_1sec
acall delay_1sec
```

main_6:

```
acallget_key
cjne keyval,#12,main_6
setb lock ; lock the device
mov a,#LCD_CLR
acalled_cmd
mov a,#OK_i
acalled_data

movdptr,#active
acallLCD_sendstring
acall delay_1sec
acall delay_1sec
ajmp main
```

main_5:

```
mov a,#LCD_CLR
acalled_cmd
mov a,#LCD_LN1
acalled_cmd
mov a,#EX_i ; ex_1 = 2
acalled_data
mov a,#2FH ; retries is memory location 33h
adda,retries
acalled_data
movdptr,#str_retry
```

```

    acall LCD_sendstring
    acall delay_1sec
    acall delay_1sec
    djnz retries,main_8
    sjmp main_7
main_8:
    ajmp main

main_7:
    mova,#LCD_CLR
    acalled_cmd
    mov a,#LCD_LN1
    acalled_cmd
    mov a,#EX_i          ; ex_i = 2
    acalled_data
    movdptr,#str_blocked
    acall LCD_sendstring
    clr alarm
    mov a,#EX_i
    acalled_data
    mov a,#LCD_LN2
    acalled_cmd
    mov a,#LOCK_i
    acalled_data
    mov a,#'
    acalled_data
    mov max,#10
    acallget_input
    mov count,#10
    movdptr,#chk_master
    acallchk
    jnbis_ok, main_7
    mova,#LCD_CLR
    acalled_cmd

```



```

mov a,#LCD_LN1
acalled_cmd
mov a,#OK_i ; ok_i = 3
acalled_data
movdptr,#str_unblocked
setb alarm
acallLCD_sendstring
acall delay_1sec
mov retries, #3
main_1:
ajmp main
set_upass:
mov a,#LCD_CLR
acalled_cmd
mov a,#LCD_LN1
acalled_cmd
movdptr,#str_master
acallLCD_sendstring
mov a,#LCD_LN2
acalled_cmd
mov a,#LOCK_i
acalled_data
mov a,#'
acalled_data
mov max,#10
acallget_input
cjne status,#TRUE,set_upass_11
mov count,#10
movdptr,#chk_master
acallchk
jnb is_ok,set_upass_11
set_upass_14:
mov a,#LCD_CLR
acalled_cmd

```

```

    mov r0,#input
    mov r1,#upass
    mov count,#5
copy_code_11:
    mov a,@r0
    mov @r1,a
    inc r0
    inc r1
    djnz count,copy_code_11
    ret

lcd_reset:                ;LCD reset sequence
movlcd_port,#0FFH
mov delay,#20            ;20mS delay
acalldelayms
movlcd_port,#83H        ;Data = 30H, EN = 1, First Init
movlcd_port,#03H        ;Data = 30H, EN = 0
mov delay,#15           ;Delay 15mS
acalldelayms
movlcd_port,#83H        ;Second Init, Data = 30H, EN = 1
movlcd_port,#03H        ;Data = 30H, EN = 0
mov delay,#5            ;Delay 5mS
acalldelayms
movlcd_port,#83H        ;Third Init
movlcd_port,#03H
mov delay,#5            ;Delay 5mS
acalldelayms
movlcd_port,#82H        ;Select Data width (20H for 4bit)
movlcd_port,#02H        ;Data = 20H, EN = 0
mov delay,#5            ;Delay 5mS
acalldelayms
ret

lcd_init:
acalld_reset            ;Call LCD Reset sequence
mov a,#28H              ;4-bit, 2 line, 5x7 dots

```

```

acalled_cmd      ;Call LCD command
mov a,#0CH       ;Display ON cursor OFF
acalled_cmd      ;Call LCD command
mov a,#06H       ;Set entry mode (Auto increment)
acalled_cmd      ;Call LCD command
mov a,#80H       ;Bring cursor to line 1
acalled_cmd      ;Call LCD command
                acallcgbuild

```

```
ret
```

```

lcd_cmd:         ;LCD command Routine
movtemp,a       ;Save a copy of command to temp
swap a          ;Swap to use higher nibble
ani a,#0FH      ;Mask the first four bits
add a,#80H      ;Enable = 1, RS = 0
movlcd_port,a   ;Move it to lcd port
ani a,#0FH      ;Enable = 0, RS = 0
movlcd_port,a   ;Move to lcd port

```

```

mova,temp       ;Reload the command from temp
ani a,#0FH      ;Mask first four bits
add a,#80H      ;Enable = 1
movlcd_port,a   ;Move to port
ani a,#0FH      ;Enable = 0
movlcd_port,a   ;Move to lcd port

```

```
mov delay,#1    ;delay 1 ms
```

```
acalldelayms
```

```
ret
```

```

lcd_data:       ;LCD data Routine
movtemp,a       ;Keep copy of data in temp
swap a          ;We need higher nibble
ani a,#0fh      ;Mask first four bits
add a,#0a0h     ;Enable = 1, RS = 1
movlcd_port,a   ;Move to lcd port

```

```

nop
clr lcd_en      ;Enable = 0

mov a,temp      ;Reload the data from temp
and a,#0fh      ;we need lower nibble now
add a,#0a0h     ;Enable = 1, RS = 1
mov lcd_port,a  ;Move to lcd port
nop
clr lcd_en      ;Enable = 0

mov delay,#1    ;Delay 1mS
acall delayms
ret

LCD_sendstring:
clr a           ;clear Accumulator for any previous data
mov a,@a+dptr   ;load the first character in accumulator
jz exit1       ;go to exit if zero
acall lcd_data  ;send first char
incdptr        ;increment data pointer
sjmp LCD_sendstring ;jump back to send the next character
exit1:
ret            ;End of routine

cgbuildk:
    mov count,#32
    mov a,#40H
    acall lcd_cmd
    movdptr,#icons

cgbuild_ll:
    clr a
    mov a,@a+dptr
    acall lcd_data
    incdptr
    djnz count,cgbuild_ll
    ret

```

delayms.

mov var1,#230

back:

nop

nop

djnz var1,back

djnzdelay,delayms

ret

keypad_init

and keyport,#0Fh ; mask unused upper four bit

ret

get_key:

mov keyval,#1 ; keyval equivalent to register 6 (r6)

mov a,#S0H ;

mov temp,#04 ; 00000100

read:

movscan,a ; scan == register 5 (r5) scan == 10000000

cpl a ; a = 01111111

andkeyport,a ; and port with register a

jb col1,next ; check key pressed in col one

jnb col1,\$; wait for key release

setbiskey

ret

next:

jb col2,next1

inckeyval

jnb col2,\$; wait for key release

setbiskey

ret

next1:

jb col3,nokey

```
inckeyval
inckeyval
jnb col3,$ ; wait for key release
setbiskey
ret
```

```
nokey:
    mova,scan ; a = 10000000
    orikeyport,a
    inckeyval
    inckeyval
    inckeyval
    r a
    mov delay,#10
    acalldelayms
    djnztemp,read ; max read time is 4
```

```
    clriskey
    ret
```

```
translate:
```

```
    mova,keyval
    cjne a,#10,jmp1
    movkeyval,'x'
    ret
```

```
jmp1:
```

```
    cjne a,#11,jmp2
    mov keyval,'#0'
    ret
```

```
jmp2:
```

```
    cjne a,#12,jmp3
    movkeyval,'#e'
    ret
```

```
jmp3:
```

```
    add a,'#0'
    movkeyval,a
```

```
ret
```

```
get_input:
```

```
mov r0,#input
```

```
mov count,#0
```

```
inc max
```

```
get_input_cnt:
```

```
acall get_key
```

```
jbis key,get_input_cnt
```

```
acall translate ; translate key pressed
```

```
mov a, keyval
```

```
mov @r0,a ; save in location 40h
```

```
cjne @r0,#'x',chk_e
```

```
mov a,count
```

```
jnz get_input_11
```

```
mov status,#EXIT ; if count is 0 move exit to status.status is r7 and
```

```
exit is 3
```

```
ret
```

```
get_input_11:
```

```
inc max
```

```
dec count
```

```
mov @r0,#0 ; save 0 to location
```

```
dec r0 ; r0 = 39h
```

```
mov a,#0C2H
```

```
adda,count
```

```
acall cmd
```

```
mov a,#'
```

```
acall data
```

```
mov a,#0C2H
```

```
adda,count
```

```
acall cmd
```

```
sjmp get_input_cnt
```

```
chk_e:
```

```
cjne @r0,#'e',chk_key
```

```

    mov @r0,#0
    dec max
    mova,max
    jnzget_input_err
    movstatus,#TRUE
    ret
chk_key:
    inc count
    djnz max, get_input_nxt
    movdptr,#get_input_err
get_input_retry:
    mov input,#0
    mova,#LCD_CLR
    acalled_cmd
    mov a,#LCD_LN1
    acalled_cmd
    mov a,#EX_i
    acalled_data
    acallLCD_sendstring
    acall delay_1sec
    acall delay_1sec
    movstatus,#RETRY
    ret
get_input_nxt:
    mov a,@r0
    acalled_data
    inc r0
    sjmpget_input_err
get_input_err:
    mov dptr,#get_input_err1
    sjmpget_input_retry
chk:
    mov r0,#input
chk_12:

```



```

    clr a
    move a,@a+dptr
    mov b,@r0
    cjne a,b,chk_11
    incdptr
    inc r0
    djnz count,chk_12
    setbis_ok
    ret
chk_11:
    clr is_ok
    ret
chk_newcode:
    mov count,#5
    mov r0,#input
    mov r1,#upass
chk_newcode_11:
    mov a,@r0
    mov b,@r1
    cjne a,b,chk_newcode_12
    inc r0
    inc r1
    djnz count,chk_newcode_11
    setbis_ok
    ret
chk_newcode_12:
    clr is_ok
    ret
delay_1sec:
    mov delay,#250
    acalldelayms
    mov delay,#250
    acalldelayms
    mov delay,#250

```

acalldelayms

mov delay,#250

acalldelayms

ret