

**DESIGN AND CONSTRUCTION OF AN
AUTOMATIC SLIDE DOOR WITH A
METAL DETECTOR AND AN ALARM
SYSTEM INCORPORATED**

BY

**UTAKE EMUOBOSA O.
2000/9936EE**

**A THESIS SUBMITTED TO THE
DEPARTMENT OF ELECTRICAL AND
COMPUTER ENGINEERING, FEDERAL
UNIVERSITY OF TECHNOLOGY, MINNA**

OCTOBER 2006

DEDICATION

This project is specially dedicated to my God Almighty and to my beloved family Mr. and late Mrs. J.O. Utake (of blessed memory) and my brothers Erhovwo (may his soul rest in peace), Oghenemine, Ajokpaoghene, and my lovely sister Enovwo.

ACKNOWLEDGEMENT

My first and sincere gratitude goes to God Almighty without who everything concerning my life and this project would have resulted in a fiasco.

I would love to use this medium to express my sincere gratitude to my beloved parents Mr. and Mrs. J.O. Utake and my siblings for their moral, material and spiritual support. I would also like to express my appreciation to Mr. and Mrs. J. Omughelli and also Mr. J.O. Okorodudu for their support in cash and kind. Finally I would also love to express my sincere gratitude to Chief and Mrs. Edoreh Agbah for their support. Finally, I would also like to use this medium to appreciate my beloved friends who have always stood by me both in the smooth and rough times.

Finally, I would like to appreciate my project supervisor Mr. J. Ajiboye who has been of great assistance throughout the period I was carrying out the project. I would also like to appreciate the HOD, Engr. Musa Abdullahi who has been like a father to me and has inspired me from a distance in so many ways. My heart also goes out to Dr. L. Onwuka who has been like a mother to me. This acknowledgement will not be complete without my mentioning the likes of Mrs Alenoghena and Dr. Tsado.

ABSTRACT

This project deals with the design and construction of an infrared controlled automatic slide-door with a metal detector and alarm units incorporated into the entire system. This was aimed at tackling the security problems that are encountered in our society today and at the same time providing an effective and basic means of entry and exit into and from a building.

This was achieved by the techniques employed in the operation of an Infrared transmitter and photodiode, alongside a comparator (LM 393) in the automatic slide door stage. The application of a colpitts oscillator in the metal detector stage also came in very handy, along with the astable and monostable multivibrators in the alarm stage.

The project was carried out using commonly available and inexpensive components and the results obtained were quite satisfactory.

Table of Contents

CONTENTS	PAGE
Dedication.....	i
Declaration.....	ii
Acknowledgement.....	iii
Abstract.....	iv
Table of Contents.....	v
List of Figures.....	vii
List of Tables.....	viii
Chapter One: Introduction.....	1
1.0 Introduction.....	1,2
1.1 General Block Diagram.....	3
Chapter Two: Literature Review.....	4
2.1 Literature Review.....	4-6
Chapter Three: Design and Implementation.....	7
3.0 Principle of Operation.....	7
3.1 Design Specifications.....	8
3.2 Transmitter Stage.....	8,9
3.3 Receiver/Amplifier Stage.....	9-12
3.4 Monostable Multivibrator.....	12-14
3.5 Combinational Logic Circuit.....	14,15

3.6	Driver Stage.....	15,16
3.7	Power Supply Stage.....	17,18
3.8	Design of Metal Detector.....	18,19
3.9	Design Specifications.....	19
3.10	Principle of Operation.....	19
3.11	Oscillator Stage.....	20-22
3.12	Comparator Stage.....	23,24
3.13	Alarm Stage.....	24,25
3.14	Comprehensive Circuit Diagram.....	26
Chapter Four: Testing, Results and Discussion.....		27
4.1	Testing.....	27-28
4.2	Problems Encountered.....	28,29
Chapter Five: Conclusions.....		30
5.1	Conclusion.....	30
5.2	Recommendations.....	30,31

LIST OF FIGURES

FIGURES	PAGE
Fig. 1.1 Generalized Block Diagram.....	3
Fig. 2.1 Simple Door Control Layout.....	6
Fig. 3.1 Transmitter Stage.....	8
Fig. 3.2 Receiver/Amplifier Stage.....	9
Fig. 3.3 Potential Divider.....	10
Fig. 3.4 Schematic diagram of monostables A and B.....	12,13
Fig. 3.5 Exclusive-OR Gate.....	14
Fig. 3.6 Switching Transistor.....	15
Fig. 3.7 Power Supply Circuit.....	17
Fig. 3.8 Ripple Gradient Curve.....	17
Fig. 3.9 Colpitts Oscillator Stage.....	20
Fig. 3.10 Search Coil (Toroid).....	21
Fig. 3.11 Comparator Stage.....	23
Fig. 3.12 Alarm Stage.....	24
Fig. 3.13 Automatic Slide-door with Metal Detector and Alarm Unit.....	26

LIST OF TABLES

TABLE	PAGE
Table 3.1 Truth Table for the Exclusive-OR Gate.....	14

CHAPTER ONE

INTRODUCTION

1.0. INTRODUCTION

In the world today, there are lots of reforms going on in various sectors of the economy especially in the banking sector, and banking is synonymous with security. It is for this reason I have decided to design an Automatic Slide-door with a Metal Detector and an Alarm System incorporated into the unit.

This project is made up of three(3) modules viz: the Automatic Slide-door unit, the Metal Detector unit, and the alarm unit.

The first module is the Automatic Slide-door unit. The sensing stage is an infra-red transmitter at one side of the passage way just before the door which has a projected infra-red beam to an infra-red receiver at the other side of the passage way. The projected beam is broken by anybody entering the door. Once broken, the infra-red receiver stage gives an output which triggers the two(2) monostable multi-vibrators. Monostable A has a time constant of 5s and monostable B, 10s. The output of both monostables goes to the input of an Exclusive-OR gate which gives an output that is low for the first 5s. Also the output of monostable A is also fed to the motor that causes the door to open (since it is high for the first 5s). After the first 5s, (the person must have passed the door by now) the output of monostable A goes low, but the output of monostable B is still high, so the output of the EXOR gate gives a high. The voltage is then fed with an opposite polarity to the motor to close the door.

The second module is the metal detector unit. It comprises an inductor, a transistor, a comparator, resistors and capacitors. If any metal is brought close to the inductor, there will be a magnetic field generated around the metal which will distort the original magnetic field around the inductor. This will cause a reduction in the voltage across the collector and the emitter. This low voltage is now fed to the non-inverting input of the comparator, which produces an output that is low. This output is then fed to the reset pins of monostables A and B (pin 4) and the trigger pin of monostable C in the alarm unit. So if a metal is detected, monostables A and B would be inactive since there is a low at pin 4.

The third module which is the alarm unit comprises a monostable and an astable multivibrator. The signal that is fed to the trigger pin of the monostable C from the output of the metal detector unit determines whether the alarm would be sounded or not. If a metal is detected, the metal detector would have an output that is low which will make the monostable C active and vice versa. The output of the monostable which is a high is then fed to the reset pin(2) of the 555 IC which triggers the alarm.

The application of this project cannot be overemphasized. Optical interruption, electronic timing functions and delay circuits, logical control (since the metal detector unit controls the slide-door and alarm unit). The project offers a great deal of security and luxury. It could be implemented in banks, insurance firms, and other financial institutions where security is paramount.

The mechanical arrangement of the door is done such that the door slides open automatically with the control of a D.C. motor and a metal bearing

mechanism upon detection of anyone approaching the door when the beam is broken. The block diagram of the entire unit in Fig. 1.1 below describes the process.

1.1. GENERAL BLOCK DIAGRAM

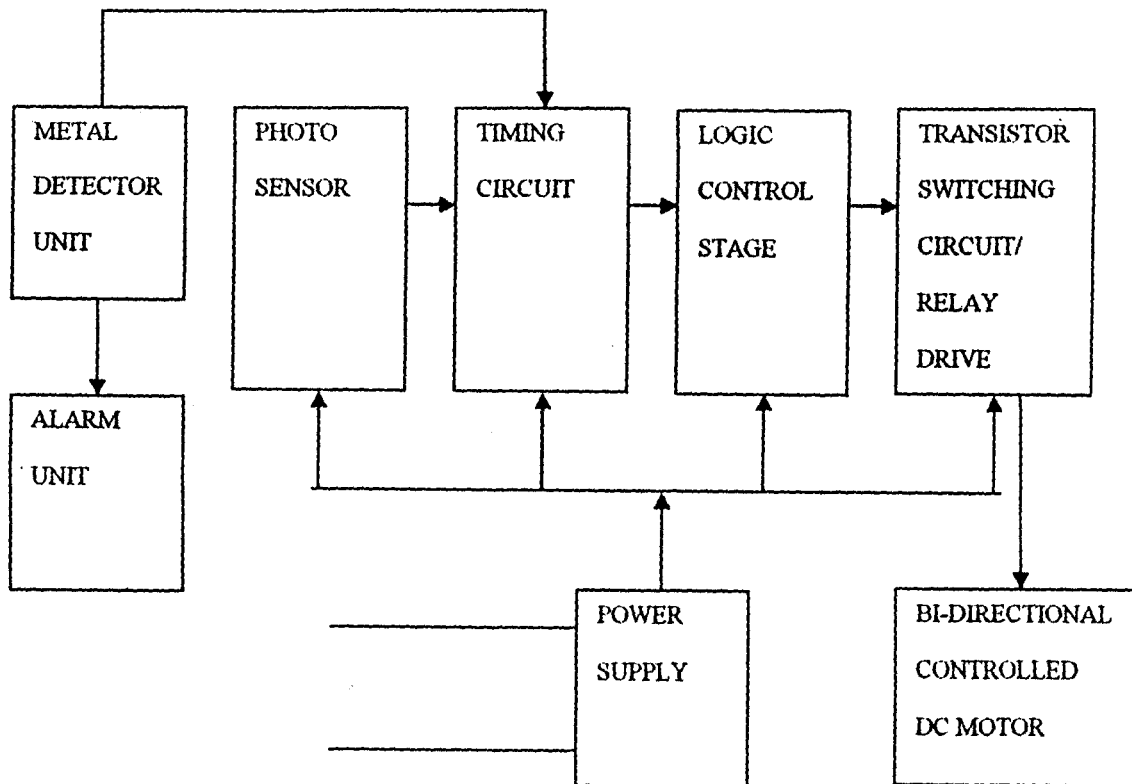

Fig. 1.1 Generalized Block Diagram

CHAPTER TWO

LITERATURE REVIEW/THEORETICAL BACKGROUND

2.1 Literature Review (Automatic Slide Door)

Basically, a door is a usually floor-length opening in a wall often equipped with a hinged or sliding panel which can be moved to leave the opening accessible, or to close it more or less securely. They are basically universal in structures of all kinds (especially buildings), allowing passage between inside and outside, or among internal rooms.

The earliest records of doors were those represented in the paintings of the Egyptian tombs, in which they are shown as single or double doors, each in a single piece of wood. The most ancient doors were in timber, those made for King Solomon's temple being in olive wood which were carved and overlaid with gold. The doors dwelt upon in Homer would appear to have been cased in silver or brass. Besides Olive wood, elm, cedar, oak and cypress were used. All ancient doors were hung by pivots at the top and bottom of the hanging stile which worked in sockets in the lintel and sill, the latter being always in some hard stone such as basalt or granite. In the Renaissance period, Italian doors were quite simple in design; their architects trusting more to the doorways for effect; but in France and Germany the contrary is the case, the doors being elaborately carved, especially in the Louis XIV and Louis XV periods.

Many centuries ago, Heron of Alexandria created the first automatic door. He was a talented Egyptian engineer and geometer in Alexandria, Egypt. The first practical automatic sliding doors for use by people were invented in 1954 by Lew

Hewitt and Dee Horto and were installed in 1960. It made use of a mat actuator. The idea came to them in the mid-1950's, when they saw that existing swing doors had difficulty operating in the high winds of Corpus Christi, Texas. Automatic doors function on electricity. Therefore, the slow development of electrical components, or electronics, really delayed the emergence of commercially important automatic doors.

Automatic doors are powered open and closed, a door fitted with a spring to close it is not an automatic door. There are three methods by which an automatic door is activated.

1 - A sensor detects traffic is approaching. Sensors for automatic doors are generally:

- A pressure sensor - a floor mat which reacts to the pressure of someone standing on it.
- An infra-red curtain or beam which shines invisible light onto sensors; if someone or something blocks the beam the door can open.
- A motion sensor which uses low-power microwave radar.
- An electronic sensor (e.g. based on infra red or radio waves) can be triggered by something that someone carries, or is installed inside a vehicle. These are popular for garage doors.

2 - A switch is operated manually, perhaps after security checks. This can be a push button switch or a swipe card.

3 - The user pushes, or pulls the door, once the door detects the movement it completes the open and close cycle. These are also known as power-assisted doors.

In addition to activate sensors automatic doors are generally fitted with safety sensors. These are usually an infra-red curtain or beam, but can be a pressure mat fitted on the swing side of the door. The purposes of the safety sensor is to prevent the door opening or slow its speed if an object is detected in its path whilst opening and to prevent the door closing or reactivate it if an object is detected in its path whilst closing.

The major part of such doors is the electromechanical unit or mechanism. The sliding door is the most widely used automatic door system. Boasting the greatest user friendliness and safety features it lends itself to volume traffic and simplicity of operation. Developed over years to a sophisticated level of intelligent control the sliding door is now available in many different styles and finishes.

Styles range from the traditional heavy duty extruded aluminum framed doors to all glass doors, slim section doors, prismatic doors, breakout doors, telescopic doors, acoustic doors, clean room doors etc all designed to meet a functional purpose or aesthetic desire. Sliding doors are the number one automatic doors and are used almost everywhere in retail outlets, airports, hospitals, offices, factories, public buildings, rail and bus stations, leisure centers, hotels, residential homes, doctors surgeries etc wherever simple, efficient access is required.

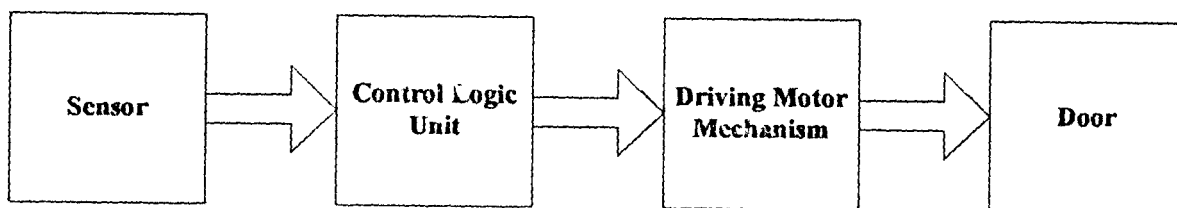

Fig. 2.1 Simple Door Control Layout

CHAPTER THREE

DESIGN AND IMPLEMENTATION

3.0 PRINCIPLE OF OPERATION

The comparator output goes low when the beam is broken and triggers the two timers. Both timers are triggered simultaneously but both of them have different time constants. The first timer has a time constant of 5s while the second timer has a time constant of 10s. When the beam is broken, both timers go to their unstable states. Timer A drives the transistor switch that controls opening of the door. Hence, the door is opened for 5s.

The timer outputs are fed to an exclusive OR gate which gives a high output only when its input is different (i.e. low and high or high and low). This implies that before breaking the beam the EXOR gate output is low and when the first timer elapses its time constant, the input of the EXOR gate becomes different and another relay is switched to make the gate close.

Closure of the gate is achieved by reversing the polarity of the supply to the motor. The relay contacts are fed with 12V d.c. (since the motor is a 12V motor) and is arranged in such a way that the polarity connected to the motor is reversed when the door is to close.

The system with a single voltage supply of +12V d.c to power the switching circuit, the relays and the other electronic circuits in the project including the TTL stage. The system gets power from mains supply.

3.1 DESIGN SPECIFICATIONS

SUPPLY VOLTAGE	-	+12V d.c.
MAXIMUM CURRENT	-	1.5A
INFRA-RED RANGE	-	500mm (for prototype door)

3.2 TRANSMITTER STAGE

The transmitter stage is not too complex since no coding is involved. The infra-red diode is forward biased to meet the electrical conditions in which it operates.

The transmitter is as shown in Fig. 3.1 below

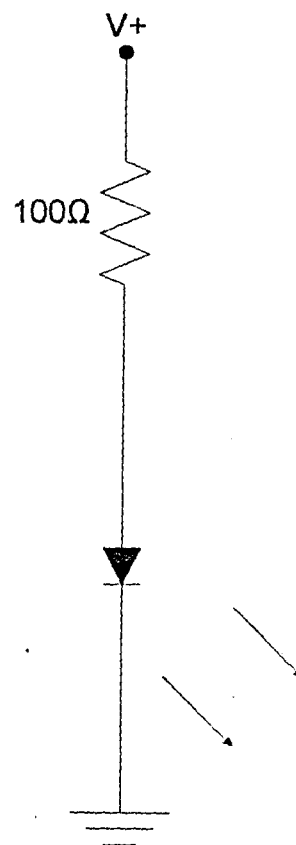

Fig. 3.1: The Transmitter Stage

D₁ is the opto device (infra-red diode) while R₁ is the limiting resistor.

V+ is gotten from the power supply

* For the diode to be forward biased,

$$V_f = 1.7V \quad (V_f = \text{maximum forward voltage})$$

$$I_f = 150\text{mA} \quad (I_f = \text{maximum forward current})$$

The resistor R will therefore be,

$$R = \frac{V+ (-V_f)}{I_f}$$

$$R = \frac{12 - 1.7}{150\text{mA}}$$

$$= 69\Omega$$

Once forward biased, the transmitter emits infra-red rays projected at an angle of about 60° from its current surface. A preferred value of 100Ω was used.

3.3 RECEIVER / AMPLIFIER STAGE

The receiver is shown in Fig. 3.2 below. The circuit employs the use of a photodiode receiver and an amplifier to enable its output drive other stages.

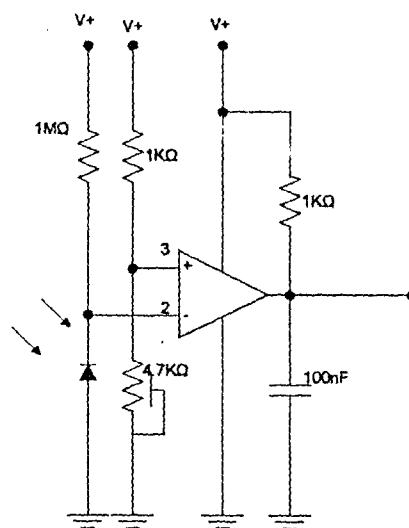

Fig. 3.2 The Receiver / Amplifier Stage

The photodiode was used as the main opto sensor due to its ability to resist day light interference better than the other optical devices mentioned.

The photodiode is operated in reverse biased condition. In darkness, the photodiode has a high resistance, hence a low forward current.

The change in resistance causes a change in the drop across R_2 , which is fed to the input of the comparator IC1.

The resistance measured from the photodiode when there is no transmission is approximately $1M\Omega$. Fig. 3.3 shows the potential divider network formed using the photodiode and resistors R_1 and R_2 .



Fig. 3.3: Potential Divider

R_1 is set at $1M\Omega$ (to allow an appreciable drop)

At $V+ = 12V$ the drop across R_2 will be

$$\frac{R_2 \times V+}{(R_1 + R_2)}$$

If V_{R1} is the drop across R_1

$$\begin{aligned}
 V_{R1} &= \frac{1M\Omega \times 12V}{1M\Omega + 1M\Omega} \\
 &= 6V
 \end{aligned}$$

R is a resistor of $1K\Omega$ whose resistance is negligible compared to that of D1.

Hence R_2 is referred to as the resistance of the diode. The resistance R_2 reduces to about $10K\Omega$ on reception of the infra-red.

Therefore V_{R2} in this case will be

$$\begin{aligned}
 V_{R2} &= \frac{10K \times 12}{6.6K + 10K} \\
 &= 7V
 \end{aligned}$$

Hence, suffice to say that the resistance drops from 6V to about zero volts with the reception of the infra-red rays.

The voltage comparator IC1 is used to compare this change with a given reference generated by R_3 and R_4 .

R_4 should vary between zero and about 7V; hence R_3 is used to drop 6V.

Therefore if drop across R_4 is 7V, and letting $R_4 = 10K\Omega$.

$$V_{R3} = \frac{R_3}{R_3 + R_4} \times V_+$$

$$6V = \frac{R_3 \times V_+}{R_3 + R_4} \quad (\text{since } V_{R3} = 6V)$$

$$= \frac{R_3 \times 12V}{10K\Omega + R_3}$$

$$R_3 = 0.5 (10K\Omega + R_3)$$

$$R_3 = 10K\Omega$$

❖ Preset value of $10K\Omega$ was used.

The use of a preset resistor is to allow is to allow variation of resistance which would give room for sensitivity of range.

When the beam is broken, the voltage to the non-inverting input drops below that of the inverting input, which makes the comparator output to fall from a high voltage level (+12V) to zero. This satisfies the condition for triggering the 555 timer, which is the next stage.

3.4 MONOSTABLE MULTIVIBRATOR

The monostable multi-vibrator creates the time constant, which enables opening and closing of the door. Two monostable stages were used; the first monostable opens the door, while the second monostable closes the door. The stages are shown in Fig. 3.4 below

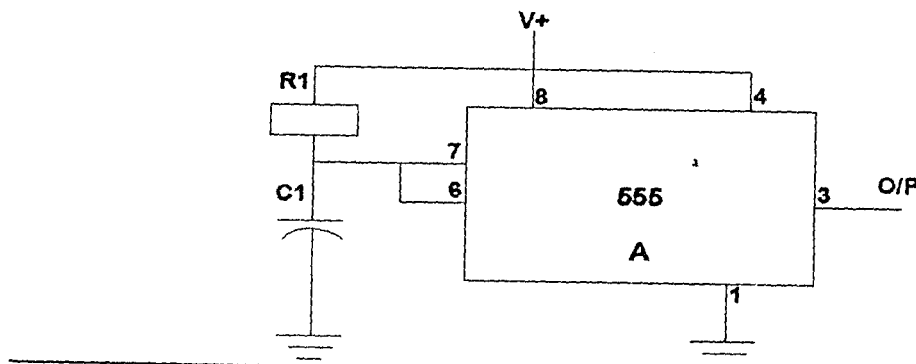

Fig. 3.4A: Schematic diagram of monostable A

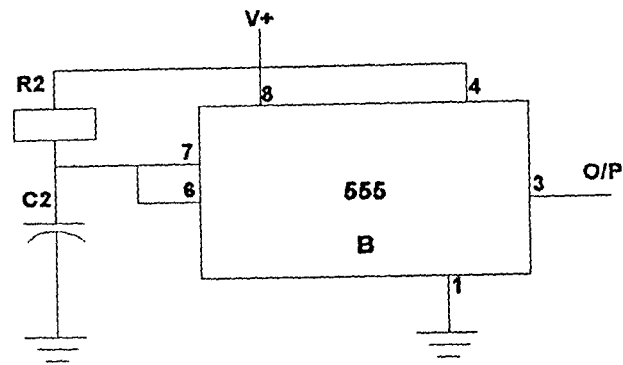

Fig. 3.4B: Schematic diagram of monostable B

Since $T = 1.1RC$

Where T = time constant (i.e. the monostable ON time)

* R = the resistor in the timing circuit and C = timing capacitor

Both monostable stages are triggered simultaneously. Monostable A has a time constant of 5s.

Therefore setting $C = 470\mu\text{F}$

$$T = 1.1R \times 470\mu\text{F}$$

For $T = 5\text{s}$

$$R = 9.6\text{K}\Omega$$

$$= 10\text{K}\Omega \text{ (preferred value)}$$

The 5s time constant was fixed because it is estimated that it would take approximately 5s to walk through the door, even if it were a disabled person.

The design is such that the XOR gate gives an output when the inputs are un-identical. Making the inputs different is achieved by having a longer time frame on monostable B; hence the duration of 10s chosen for monostable B, so that the remaining 5s would switch another relay, which closes the door.

For monostable B, let $C = 100\mu\text{F}$ and $T = 10\text{s}$

$$\begin{aligned}
 R &= \frac{10s}{1.1 \times 100\mu F} \\
 &= 90.9K\Omega \\
 &= 100K\Omega \text{ (preferred value)}
 \end{aligned}$$

The 100KΩ preferred value was used. Though there might be a little time difference but this could be neglected.

3.5 COMBINATIONAL LOGIC CIRCUIT

An exclusive-OR gate was used to determine when the door should close or open. The exclusive-OR gate is shown in Fig. 3.5 below,

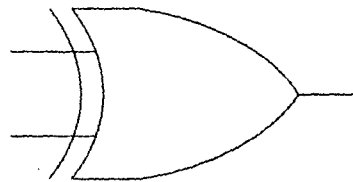

Fig. 3.5 Exclusive-OR Gate

Table 3.1 Truth table for the XOR gate

INPUT		OUTPUT
A	B	C
0	0	0
0	1	1
1	0	1
1	1	0

From the table it can be shown that when the inputs are identical, the output is

zero. The two monostable outputs are LOW before triggering and simultaneously go to a HIGH after triggering until the time constant of monostable A elapses (i.e. 5s). When this happens, the output of the XOR gate goes high for the remaining time duration during which monostable B is active and closes the door before going back to a low state.

3.6 DRIVER STAGE

The driver stage is composed of a switching transistor stage, which switches the relay that controls the D.C. motor. Two switching transistors are used. This is to enable alternate switching to allow for movement of the motor in both directions. The circuit diagram of the switching transistor is shown in Fig. 3.6.

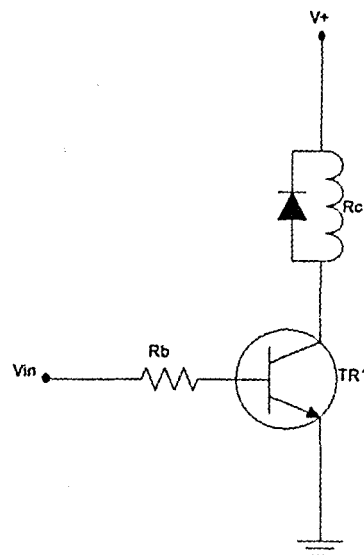

Fig. 3.6 The Switching Transistor

Where R_c is the coil resistance of the relay,

R_B is the base resistor,

V_+ is supply voltage = 12V

V_{IN} is input voltage = 5V

TR 1 is the switching transistor

From our theoretical knowledge of transistors, it could be recalled that,

$$V_+ = I_C R_C + V_{CE}$$

Since the transistor is acting as a switch, $V_{CE} = 0$

Since $R_C = 400\Omega$. (coil resistance)

$$I_C = \frac{V_+}{R_C}$$

Since $R_C = 400\Omega$ (coil resistance)

$$\begin{aligned} I_C &= \frac{12}{400} \\ &= 0.03A \end{aligned}$$

$$\text{We recall that } I_B = \frac{I_C}{h_{fe}}$$

$$= 0.03/300 \text{ (} h_{fe} = 300 \text{ from data sheets)}$$

$$= 100\mu A$$

$$\text{Also } V_{in} = I_B R_B + V_{BE}$$

$$5 = 100\mu A R_B + 0.6V \text{ (where } 0.6 = V_{BE} \text{ for silicon, where } V_{in} = 5V \text{ from}$$

monostable and exclusive OR gate stages)

$$\begin{aligned} \text{Therefore } R_B &= \frac{5 - 0.6}{100\mu A} \\ &= 44K\Omega \end{aligned}$$

A preferred value of $47K\Omega$ was however used.

The diode across the coil is used to protect the transistor against back e.m.f. which might arise from the coil since it is an inductive load.

3.7 POWER SUPPLY STAGE

All stages in the project uses +12V d.c. The power supply stage is a linear power supply type and involves a step down transformer, filter capacitor, and a voltage regulator to give the required voltage level. The power supply circuit diagram is shown in Fig. 3.7.

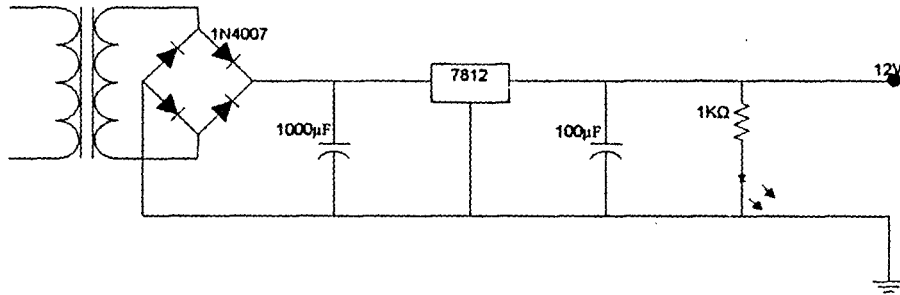

Fig. 3.7 Power Supply Circuit

The rectifier is designed with four diodes to form a full wave bridge network. C_1 is the filter capacitor and C_1 is inversely proportional to the ripple gradient of the power supply. Fig. 3.8 shows the ripple gradient.

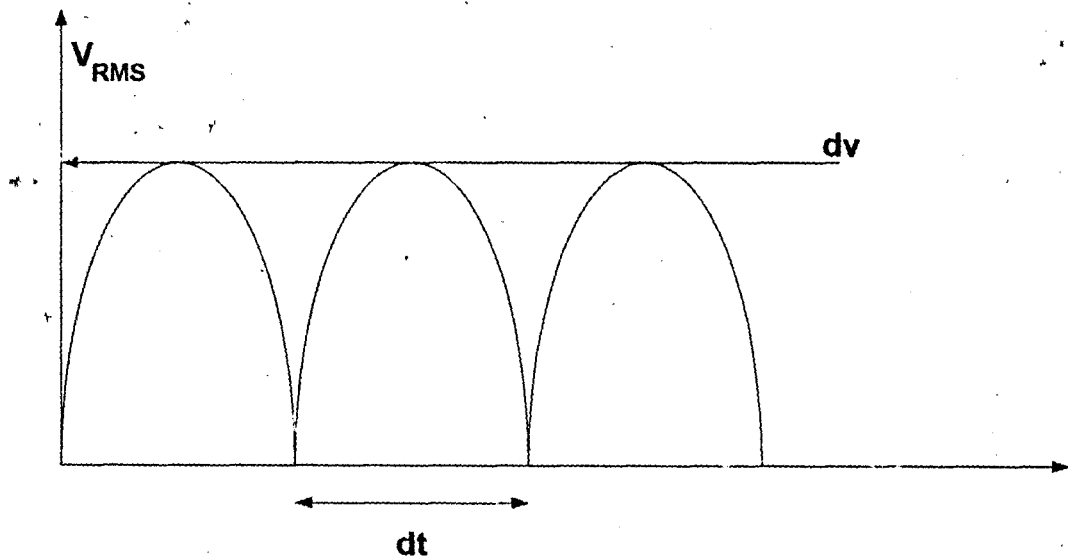

Fig. 3.8 Ripple Gradient Curve

Where dv is the ripple voltage for time dt , where dt is dependent on power supply frequency.

For an r.m.s. voltage of 15V (from transformer)

$$\begin{aligned}V_{\text{peak}} &= 15 \times \sqrt{2} \text{ (i.e. r.m.s.} \times \sqrt{2}\text{)} \\ &= 21.2\text{V}\end{aligned}$$

Hence letting a ripple voltage of 15% makes $dv = 3.18$

$$\text{But } \frac{1}{C} = \frac{dV}{dt}$$

3.8 DESIGN OF METAL DETECTOR

The design and implementation of this project was carried out under the following headings.

The Oscillator stage/search coil

Comparator/calibrator stage (peak detector)

Alarm stage

Power Supply Unit.

A generalized block diagram showing the various integral stages of the project is shown in figure while the comprehensive circuit diagram is in unit

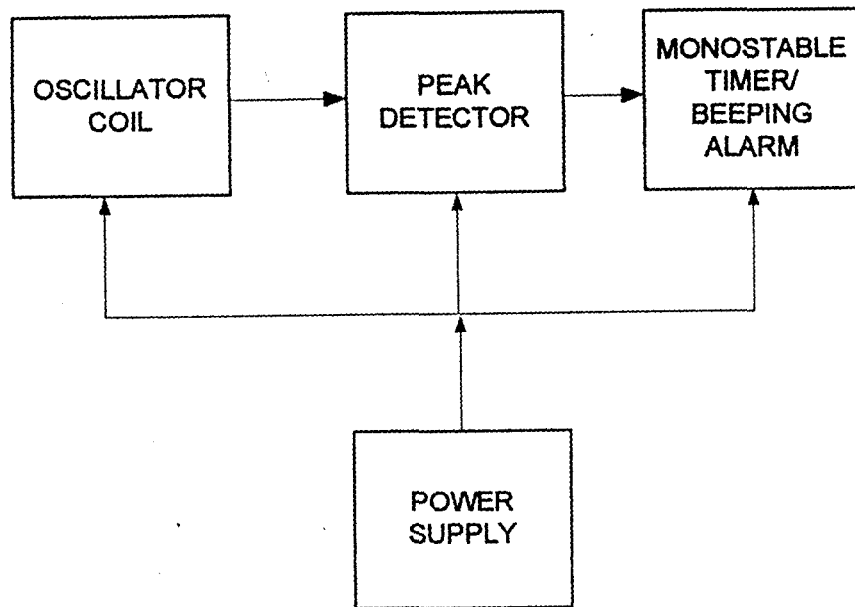

3.9 DESIGN SPECIFICATIONS

Supply voltage: 12VDC.

Detection range: 3-inches max.

Detection type: Beat frequency (digitized).

Alarm type: Beeping alarm.

3.10 PRINCIPLE OF OPERATION

The metal detector uses the beat frequency technique whereby an inductor is a search coil, which forms part of an LC network circuit. The LC network is part of a colpitts oscillator stage, which oscillates at a constant frequency. The field strength of the coil reduces as a metal enters the field, which consequently tends to dampen the oscillations and also drift the frequency. The output is fed to a peak detector (which senses the dc

level) and comparators with a variable reference for sensitivity adjust. Once a metal enters the field, the output of the comparator goes LOW and triggers a monostable stage for time T, during which a beeping alarm is triggered.

3.11 OSCILLATOR STAGE / SEARCH COIL

The oscillator stage is designed using a colpitts oscillator where the search coil is the inductor L. Fig 3.9 shows the oscillator circuit. The oscillator stage generates a varying output when the metal is in the field.

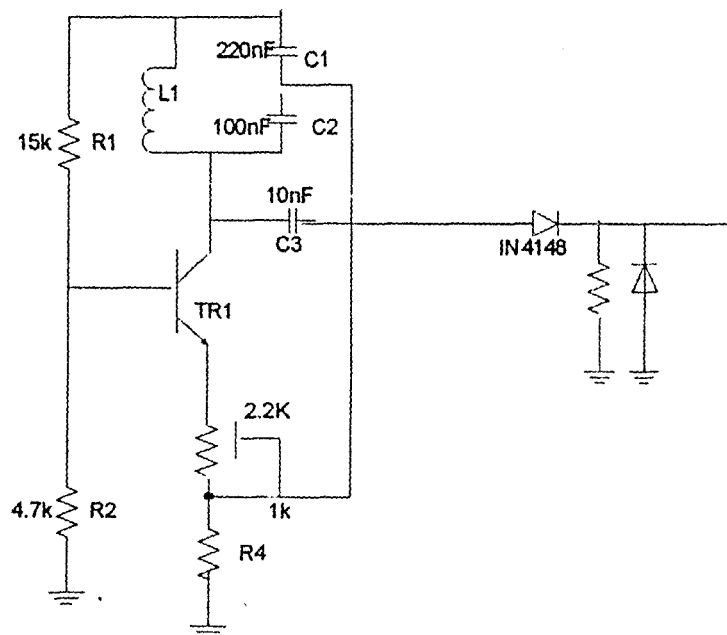

Fig 3.9 Colpitts Oscillator Stage

For the colpitts oscillator stage the frequency of oscillation f_o , is given by,

$$f_o = \frac{1}{2\pi\sqrt{LC}}$$

Where:

$$f_o = 10\text{KHz} = 10,000\text{Hz}$$

$$C = \frac{C_1 C_2}{C_1 + C_2}$$

$$C_1 = 100\text{nF} = 100 \times 10^{-9} \text{F} = 1 \times 10^{-7} \text{F}$$

$$C_2 = 220\text{nF} = 220 \times 10^{-9} \text{ F} = 2.2 \times 10^{-7} \text{ F}$$

$$L = ?$$

$$C = [C_1 C_2 / (C_1 + C_2)] = [(1 \times 10^{-7}) \times (2.2 \times 10^{-7})] / [(1 \times 10^{-7}) + (2.2 \times 10^{-7})]$$

Therefore,

$$C = 6.875 \times 10^{-8} \text{ F (or 68.75nF)}$$

Transposing L and substituting for all the values in f_o ,

$$f_o = 1 / (2\pi\sqrt{LC})$$

$$L = 1 / (2\pi f_o)^2 \times C$$

$$L = 1 / [(2 \times 3.14 \times 1000)^2 \times 6.875 \times 10^{-8}]$$

$$L = 0.368814519\text{H (or 368.8mH) being inductance } (\beta).$$

To get a uniform field, a toroid has to be designed to represent the inductor of inductance = 368.8mH.

Fig 3.10 below shows the search coil (toroid).

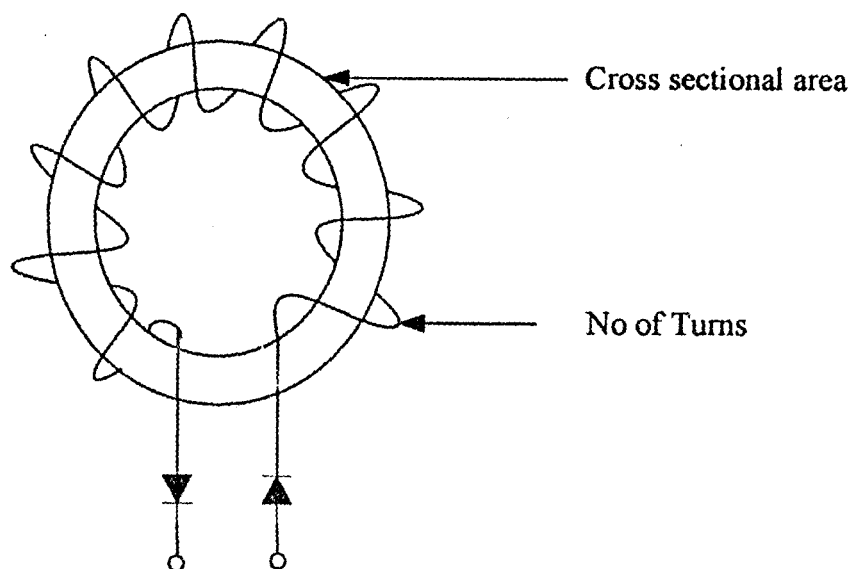

Fig 3.10 Search Coil (Toroid).

Where the inductance $(\beta) = [(\mu_o AN^2) / L_o]$

Therefore, $\beta = [(\mu_0 AN^2) / L]$

The no of turns to give the desired inductance would be calculated.

Where: μ_0 is permeability of vacuum (Hm^{-1})

A is cross-sectional area (m^2)

N is number of turns of windings

L_0 is length of loop

Since $\beta = 368.8\text{mH}$

and $\mu_0 = 4\pi \times 10^{-7} \text{Hm}^{-1} = \text{a constant}$

For $L_0 = 15\text{cm} = 0.15\text{m}$ loop length

and $A = \pi r^2$

where $d = 1\text{cm} = 2r$

Therefore, $r = 0.5\text{cm}$

Thus $r^2 = (0.5)^2$

$A = \pi \times (0.5)^2$

$A = [(22/7) \times 0.25] = 0.79\text{cm}^2$

From the equation,

$\beta = [(\mu_0 AN^2) / L_0]$

Substituting for all the values,

$0.368814519 = [(4\pi \times 10^{-7}) \times 0.79 \times N^2] / 0.15]$

Therefore, $N^2 = [(L_0 \times \beta) / (\mu_0 \times A)]$

Therefore, $N = 236$ turns.

Hence winding 236 turns for the inductor will give the required inductance.

Resistors R1, R2 and R4 are dc bias resistors for the transistor T1.

3.12 COMPARATOR/CALIBRATOR STAGE (PEAK DETECTOR)

The peak detector output is fed to the inverting input of the comparator, where it is compared with a reference voltage (akin to a reference oscillator in the analog beat frequency type). When metal enters the field, the voltage at the comparator input drops below the reference to give a LOW output that triggers a 555 timer monostable stage.

Fig 3.11 below shows the comparator stage.

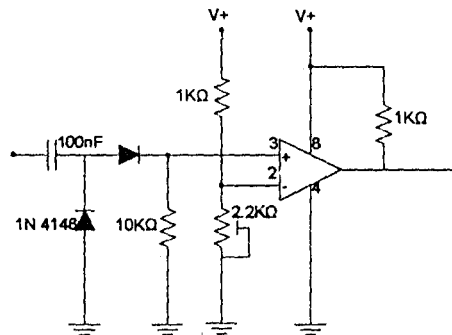

Fig 3.11 Comparator Stage

VR2 is set at 2.6V (this is because when metal is detected the voltage drops from approximately (4V to 1.5V); any voltage below 2.6V in the inverting input will make the output of the comparator go low, to trigger the monostable stage since,

$$V_{out} = A_0 V_{in}$$

Where A_0 = open loop voltage gain.

$$\text{and } V_{in} = V_1^+ - V_1^-$$

V_{out} will drop to 0V for the slightest negative difference in voltage since A_0 is often very large (in order of 20000).

3.13 ALARM STAGE

The alarm stage is comprised of a one-shot monostable and astable multivibrator. The monostable is triggered when the metal is detected (to enable timing of the alarm for a specific duration), while the astable generates the beeping tone.

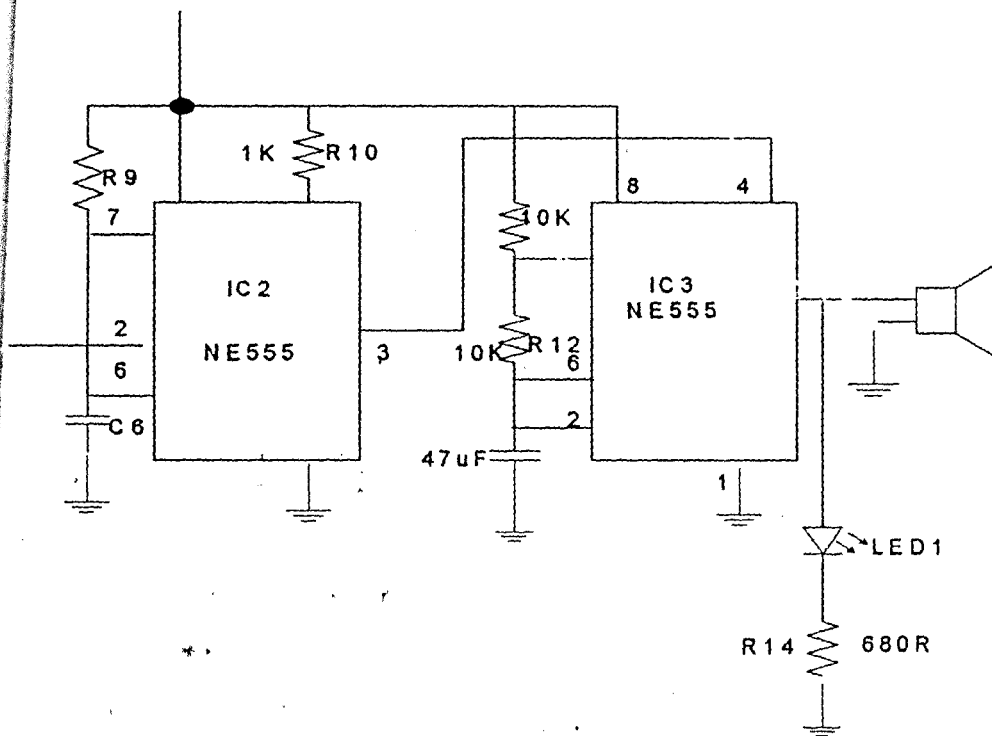

Fig 3.12 Alarm Stage

The one-shot monostable stage generates one shot of clock pulse each time the search coil detects a metal. It is triggered from the output of a comparator, which senses the break beam.

The one shot monostable is built around IC2 in Fig 3.2.4. Since $T = 1.1RC$, and the time duration of the monostable is 5s. (To allow for continuous beeping for time T, after metal has been detected).

Letting $C=100\mu F$,

Gives $R = 5 / 1.1 \times 100 \mu\text{f}$

$$= 9.09\text{K}$$

$$= 45.5\text{K}\Omega.$$

A preferred value of $47\text{K}\Omega$ was used.

IC3 in fig 3.4a forms the astable oscillator stage.

For a frequency of 1Hz,

$$t_1 = 1.1C(R_1 + R_2) \text{ seconds (where } t_1 = \text{ON time)}$$

$$t_2 = 0.693CR_2 \text{ seconds (where } t_2 \text{ is the OFF time)}$$

Since $F = 1/T$

and $T = t_1 + t_2$

$$F = 1 / \ln 2C(R_1 + 2R_2) \text{ seconds}$$

$$F = 1.44 / (R_1 + 2R_2) C \dots\dots\dots(1)$$

Letting $R_1 = 10\text{K}$ and $C = 47\mu\text{F}$

Substituting the values into equation 1

$$R_2 = 10.3\text{K}$$

$$= 10\text{K (preferred value).}$$

Therefore $R_{11} = R_{12} = 10\text{K}$, & $C_7 = 47\mu\text{F}$.

3.14 COMPREHENSIVE CIRCUIT DIAGRAM

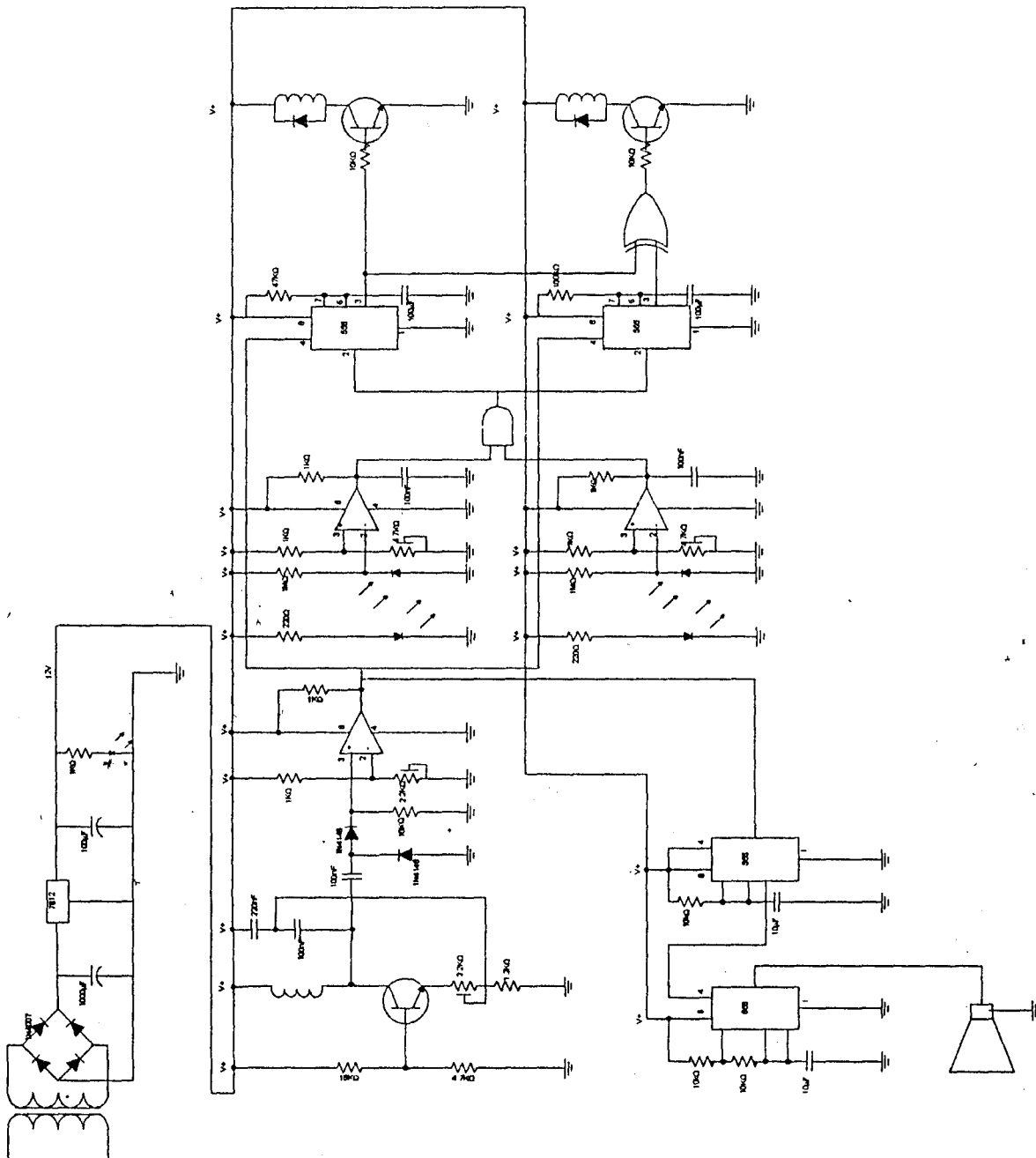

Fig. 3.13 Automatic Slide-door with Metal Detector and Alarm Unit

CHAPTER FOUR

TESTING, RESULTS AND DISCUSSION

4.1 TESTING

The physical realization of the project is very vital. This is where the fantasy of the whole idea meets reality. The designer will see his or her work not just on paper but also as a finished hardware.

After carrying out all the paper design and analysis, the project was implemented and tested to ensure its working ability, and was finally constructed to meet desired specifications. The process of testing and implementation involved the use of some equipment stated below.

- i. **BENCH POWER SUPPLY:** This was used to supply voltage to the various stages of the circuit during the breadboard test before the power supply in the circuit was built. Also, during the soldering of the project the power supply was still used to test various stages before the d.c power supply used in the project was finally constructed.

- ii. **OSCILLOSCOPE:** The oscilloscope was used to observe the ripples in the power supply waveform and to ensure that all waveforms are correct and their frequencies are accurate. The waveform of the comparator output was checked to see if there were any hysteresis signals which could trigger the monostable falsely.

iii. **DIGITAL MULTIMETER:** The digital multimeter basically measures voltage, resistance, continuity, current, frequency, temperature, and transistor gain. The process of implementation of the design on the board required the measurement of parameters like, voltage, continuity, resistance values of the components and in some cases frequency measurement. The digital multimeter was used to check the various voltage drops at all stages in the project, and most importantly the infrared receiver stage, to help check the references in the comparator circuit. Also the Digital multimeter was used for troubleshooting during the soldering and coupling.

4.2 PROBLEMS ENCOUNTERED

Several problems were encountered during the project. The problems range from design problems to implementation problems and also construction problems. The major problems are as follows:

1. Inability to turn the motor in both directions. This was the first design challenge the project posed. The problem was solved by using two relay drivers and combinational logic circuit (i.e. the exclusive OR gate). The relay contacts are arranged in such a way that their polarity is reversed when alternative occurs.
2. Short circuiting of the ground and the V+, this resulted in the heating up of the voltage regulator and ICs, but the digital multimeter was used to tackle this problem by testing for continuity.

3. Also, exact calculated values for components were gotten. Preferred values were used instead and this caused drifts in time constant of the timers but these drifts were negligible since they were within range and didn't disturb the opening and closing of the door.
4. Other problems include soldering and measurement errors but these problems were solved by proper troubleshooting serious care in the construction of the project.
5. The problem of false triggering in the metal detector and alarm sections of the project was taken care of by incorporating a delay circuit in the alarm section.

CHAPTER FIVE

CONCLUSIONS

5.1 CONCLUSION

The design, construction and testing of an automatic slide door with a metal detector using infrared as it's motion detector was carried out in this project. The following factors were considered during the implementation of the project: availability of electrical components and research materials, economy and durability. The performance of the project after testing met design specifications.

However, the overall performance was dependent on the presence of the object entering the door, the material of which the object was made from, and the proximity of the object to the door. The door was meant to open automatically but in a case where there is no power supply, trying to force the door open would damage the mechanical control system in the unit.

Also, proper positioning of the components on the Vero board was needed to avoid heat radiation on the IC's which affects the performance of the entire system. Then, the final construction was made for easy maintenance and repairs in the event of fault.

Generally, this project involved research in both analog and digital electronics. Intensive Research was carried out on timers, logic control circuits, relays and optodevices.

5.2 RECOMMENDATIONS

I would recommend that further work be done on the following areas to improve the efficiency of the project:

- 1) A backup power supply should be designed since the system cannot work without constant supply just like any other automatic system (e.g. an inverter, UPS or a standby generator).
- 2) A software model of the design should be done to enable further research and improve the performance of the system to include a 3-D version door or control of multiple doors simultaneously.
- 3) The department should make available more research-oriented books in the departmental library, to make enough materials available for students use.
- 4) Students should be exposed to practical application of electronics on time (preferably in their first year) so that they will be familiar with the various ICs and their functions.
- 5) Qualified lecturers who have on-the-field experience should be employed so that it would not just be a garbage in-garbage out issue.
- 6) The department should make provisions for excursions, workshops, seminars etc so that the students can really appreciate their course and have an idea of the challenges that awaits them.

REFERENCES

1. BERNARD GROB, Basic Electronics, 4th Edition, pp 599-630.
2. HOLT C. A., Electronics circuits: Digital and Analogue (1978) pp 22.
3. MITCHELL F. H., Introduction to Electronic Designs (1982) pp. 85-86.
4. RICHARD C. D., Introduction to Electronic circuits, New Edition (1986) 208-215.
5. THERAJA B. L and THERAJA A. K, Electrical Technology, S. Chand and company Ltd, India, (1999), pp 1699-1720, 1734-1737, 1998-2006.
6. PEATMAN J. B., Digital Hardware Design. (1980) pp 47-50.
7. BERNARD GROB, Basic Electronics, 4th Edition, pp 599-630.
8. INTERNET: www.electroforu.net
9. INTERNET: www.electronic-labs.com
10. INTERNET: www.farnellcomponents.com
11. INTERNET: www.wikipedia.org
12. ECG PHILLIPS, ECG DATA BOOK (1999).