

**DESIGN OF STREET LIGHT ARRANGEMENT  
FOR A ROAD OF 5KM USING MERCURY  
VAPOUR LAMP WITH A MINIMUM  
ILLUMINANCE OF 15 LUX AT THE CENTRE OF  
THE ROAD AND 8 LUX AT THE ROAD KERBS.  
ALSO PROVIDE THE POWER SUPPLY  
NETWORK.**

**BY**

**ABUBAKAR HUSSAINI SANI**

**MATRICULATION NUMBER:**

**2005/21984EE**

**ELECTRICAL AND COMPUTER ENGINEERING  
DEPARTMENT**

**SCHOOL OF ENGINEERING AND ENGINEERING  
TECHNOLOGY**

**FEDERAL UNIVERSITY OF TECHNOLOGY, MINNA**

**NOVEMBER, 2010**

**DESIGN STREET LIGHT ARRANGEMENT FOR  
A ROAD OF 5KM USING MERCURY VAPOUR  
LAMP WITH A MINIMUM ILLUMINANCE OF 15  
LUX AT THE CENTRE OF THE ROAD AND 8  
LUX AT THE ROAD KERBS. ALSO PROVIDE  
THE POWER SUPPLY NETWORK.**

**BY**

**ABUBAKAR HUSSAINI SANI**

**MATRICULATION NUMBER:**

**2005/21984EE**

**A FINAL YEAR PROJECT SUBMITTED TO THE DEPARTMENT OF ELECTRICAL  
AND COMPUTER ENGINEERING, SCHOOL OF ENGINEERING AND  
ENGINEERING TECHNOLOGY, FEDERAL UNIVERSITY OF TECHNOLOGY,  
MINNA, IN PARTIAL FULFILMENT OF THE REQUIREMENTS OF THE AWARD  
OF THE BACHELOR OF ENGINEERING (B. ENG.) DEGREE IN ELECTRICAL  
AND COMPUTER ENGINEERING**

**NOVEMBER, 2010**

## **DEDICATION**

This project work is solely dedicated to the Holy prophet Mohammed (S.A.W.), my dear Father Late Alhaji Abubakar Sani, My lovely Mother Hajiya Luba A. Sani.

## DECLARATION

I Abubakar Hussaini Sani, declare that this work was done by me and has never been presented elsewhere for the award of degree. I also hereby relinquish the copyright to the Federal University of Technology, Minna.

ABUBAKAR HUSSAINI S.

(Name of student)

*Abubakar Hussaini Sani* 29/10/2010

(Signature and date)

PROF. ORIA USIFO

(Name of Supervisor)

*[Signature]* 29/10/10

(Signature and date)

ENGR. A.G RAJI.

(Name of H.O.D)

*[Signature]* (Jan. 11, 2011)

(Signature and date)

*Eng. Dr. G.T. Igheb*

(Name of External Examiner)

*[Signature]* 1/12/10

(Signature and date)

## ACKNOWLEDGEMENT

All praise is due to Allah, the Lord of the world, the omnipotent, the omnipresent, the omniscient whose grace accomplishes all good things, who gave me all necessary guidance, motivation, inspiration and courage through the challenging path of this academic height. I pray for Allah's blessing and perfect peace on the guiding mercy for all creation.

I am particularly indebted to my project supervisor; Prof. Oria Usifo whose commitment to this project work at all stages gave me encouragement. I am indebted to entire staff of the department whose effort criticism and remarks did a lot of good to me and my work.

My profound gratitude goes to my dearest parents Late Alhaji Abubakar Sani and Hajiya Luba A.S Sani whose efforts and supports actualize my dreams. In fact, I appreciate the moral and financial support given to me by Alhaji (Dr) Shehu Musa whose are always assiduous to the success of my program.

I appreciate the assistance, advice and encouragement rendered to the success of my program in one way or the other by my brothers and sisters who are Mainasara A.S Sani, Yusuf A.S Sani, Shehu A.S Sani, Hauwa'u A.S Sani, Bilyaminu A.S Sani, my twin brother Hassan A.S Sani and our last born Sumayya A.S Sani. My acknowledgment will not be completed without remembering Alhaji Attahiru Bafarawa Former Governor of Sokoto State.

I also want to thank my friends Muhammad Adamu Aboki, Musa Umar, Amir Aliyu Magaji, Salihu Ojo, Abubakar Anka, Kamal, Sadiq Bomo, Faiza Age, Azeza Age, Abubakar Guru and the rest. May Allah in his infinite mercy bless you All (Ameen).

## ABSTRACT

This project presents the design of street light arrangement for a road of 5km, the point by point method of illumination was used to fully illuminate the 5km road. The minimum illuminance specified for the centre of the road (15lux) and road kerbs (8lux) was used in calculating the minimum illuminance and consequently the number of lamps required to provide the desired illuminance.

The total power required by all lamps used was calculated and appropriate fusing circuit was provided, this was also used in determining the rating of step down transformer required to supply the street lights. A comprehensive power supply network diagram was drawn to show in detail the different stages of power transformation.

# TABLE OF CONTENTS

Cover Page.....	i
Title Page.....	ii
Dedication.....	iii
Declaration.....	iv
Acknowledgement.....	v
Abstract.....	vi
Table of Contents.....	vii
List of figures.....	x
List of tables.....	xi
<b>CHAPTER ONE: GENERAL INTRODUCTION.....</b>	<b>1</b>
1.1 Introduction.....	1
1.2 History of street lights.....	2
1.3 Statement of problem.....	3
1.4 Aims and Objectives.....	4
1.5 Project Motivation.....	5
1.6 Scope of project.....	5
1.7 Limitation.....	6
<b>CHAPTER TWO: THE THEORY OF DESIGN.....</b>	<b>7</b>
2.1 Site Discription.....	7

2.2 Power Distribution.....	7
2.2.1 Incoming Service Cables.....	9
2.2.2 Final Sub Circuits.....	9
2.3 Cables.....	12
2.3.1 Cable Categories.....	12
2.3.2 Underground Cables.....	12
2.3.3 Over Head Cables.....	13
2.4 PROTECTION.....	14
2.4.1 Methods of protection.....	14
2.4.2 Earthing.....	14
2.4.3 Methods of Earthing.....	16
2.5 TRANSFORMER.....	16
2.5.1 Basic principle of operation.....	16
2.5.2 Feeder pillar.....	18
2.6 METALLIC POLES.....	18
2.6.1 Poles Discription.....	18
2.7 LIGHTING.....	18
2.7.1 Lighting fixtures.....	19
2.7.2 Types of lighting.....	20



2.7.3 Methods of lighting.....	20
2.7.4 Forms of lighting.....	21
2.7.5 Lighting installations.....	22
<b>2.8 ILLUMINATION.....</b>	<b>30</b>
2.8.1 Basic terms used in illumination engineering.....	30
<b>2.9 HISTORIC PERSPECTIVE OF THE POINT METHOD.....</b>	<b>35</b>
2.9.1 The point by point method.....	35
2.9.2 Calculation of illumination.....	37
2.9.3 Illumination formulae.....	37
<b>CHAPTER THREE: DESIGN PROCEDURE.....</b>	<b>39</b>
3.1 Lighting Requirement.....	40
3.2 Calculation of total lumen required .....	41
3.3 Calculation of total number of lamps required for each pole.....	45
3.4 Load calculation and power requirement.....	45
3.4.1 Power consumed per phaseCalculation of total line current .....	45
3.4.2 Calculation of total line current .....	46
3.4.3 Distribution board lay-out .....	46
3.5 Choice of cables.....	49
3.6 Choice of transformer.....	49

3.7 Power Supply diagram.....	50
3.8 Recommended design criteria.....	51
<b>CHAPTER FOUR: DESIGN IMPLEMENTATION AND COSTING.....</b>	<b>51</b>
4.1 Lighting.....	52
4. Streetlight poles.....	53
4.4 Total cost of project.....	54
<b>CHAPTER FIVE: CONCLUSION.....</b>	<b>55</b>
5.1 Significance.....	55
5.2 Limitation.....	55
5.3 Conclusion and Recommendation.....	56
<b>REFERENCES.....</b>	<b>57</b>

## LIST OF FIGURES

Fig. 2.1	Diagram of a two lane road .....	7
Fig. 2.2	Single stage distribution.....	8
Fig. 2.3	Three tage distribution.....	9
Fig. 2.4	Sequence of supply controls.....	11
Fig. 2.5	Diagram of an ideal transformer.....	17
Fig. 2.6	Diagram of a Tungsten filament lamp .....	24
Fig. 2.7	Diagram of a Tungsten halogen lamp .....	26
Fig. 2.8	Starting the fluorescent lamp .....	27
Fig. 2.9	Mercury vapor lamp .....	28
Fig. 2.10	The Sodium vapor lamp .....	29
Fig. 2.11	The point by point method.....	36
Fig. 2.12	Illuminance on a point.....	36
Fig. 3.1	Block diagram to illustrate design procedure .....	39
Fig 3.2	Street light pole illuminating a road.....	40
Fig. 3.3	Relationship between H, X and D .....	41
Fig. 3.4	Dimensioning of road and positioning of poles .....	42
Fig 3.5	power network diagram.....	47
Fig 3.6	Distribution board schematic diagram.....	48

Fig 3.7 power suply network diagram.....50

### LIST OF TABLES

Table 3.1 Recommended design criteria.....51

Table 4.1 Cost table for mercury vapour lamp .....52

Table 4.2 Cost table for streetlight poles.....53

Table 4.3 Cost table for power and lighting.....53

# CHAPTER ONE

## 1.1 INTRODUCTION

Streets play a major role in shaping the form of any urban environment. The quality of the street is a key element in the growth and development of any community.

Streets serve a variety of purposes. One is for the circulation of people, vehicles, goods, and services (utilities). Streets also serve as shopping corridors, restaurant rows, linear parks, residential front yards, extensions of office lobbies, ceremonial gathering places, parade grounds, racing courses, display areas, entertainment strips, etc. In a nutshell, the street is the city organized along a corridor. It is a continuous forum of gathering where all those activities have their overture, making city life what it is. It has economic, social, aesthetic, political, ecological and even philosophical-implications. No developing society can attain a well organized structure and economic stability without streets. However most well developed streets are not carrying out all the above functions simply because they are not properly illuminated at night, hence the need for a street light.

A Street light, lamp post, street lamp or lamp standard is a raised source of light on the edge of a road, which is turned on or lit at a certain time every night. Modern lamp may also have light sensitive photocells to turn them on at dusk, off at dawn or activate automatically in dark weather. A well designed and constructed street light will provide any street with all that is required to benefit its residents.

Major advantage of street lighting includes: prevention of accidents and increase in safety. Studies have shown that darkness results in a large number of crashes and fatalities,

especially those involving pedestrians; pedestrian fatalities are 3 to 6.75 times more vulnerable in the dark than in daylight. Street light has been found to reduce pedestrian crashes by approximately 50%. Furthermore, lighted intersections and highway interchanges tend to have fewer crashes than unlighted intersections and interchanges.

This project will show in details how to design a street light.

## **1.2 HISTORY OF STREET LIGHTS**

The earliest lamp were used by Greek and roman civilizations, where light primarily served the purpose of security, both to protect the wanderer from tripping over something on the path as well as keeping the potential robbers at bay. At that time oil lamps were used predominantly as they provided a long-lasting and moderate flame. The Romans had a word 'laternarius', which was a term for slave responsible for lighting up the oil lamps in front of their villas. This task continued to be kept for a special person as far as up to Middle Ages where the so-called 'link boys' escorted people from one place to another through the murky winding streets of medieval towns.

Before incandescent lamps, gas lighting was employed in cities. The earliest lamps required that a lamplighter tour the town at dusk, lighting each of the lamps, but later designs employed ignition devices that would automatically strike the flame when the gas supply was activated. The earliest of such street lamps were built in the Arab Empire, especially in Cordoba, Spain. The first modern street lamps, which used kerosene, were introduced in Lviv in what was then the Austrian Empire in 1853.

The first electric street lighting employed arc lamps, initially the 'Electric candle', 'jablotchkoff candle', or 'Yablochkov candle' developed by Russian Pavel Yablochkov in 1875. This was a carbon arc lamp employing alternating current, which ensured that both electrodes

were consumed at equal rates. Yablochkov candles were first used to light the Grands Magasins du Louvre, Paris where 80 were deployed, improvement which is one of the reasons why Paris earned its 'City of Lights' nickname. Soon after, experimental arrays of arc lamps were used to light Holborn Viaduct and the Thames Embankment in London – the first first electric street lighting in Britain. More than 4,000 were in use by 1881, though by then an improved differential arc lamp had been developed by Friederich von Hefner – Alteneck of Siemens and Halske. The United States was swift in adopting arc lighting, and by 1890 over 130,000 were in operation in the U.S, commonly installed in exceptionally tall moonlight towers.

The first street in UK to be lit by electric light was Moosely Street, in Newcastle-upon-Tyne. The street was lit by Joseph Swan's incandescent lamp on the 3<sup>rd</sup> February, 1879. The first in the United States and the second overall was the Public Square road system in Cleveland, Ohio, on April 29, 1879. Wabash, Indiana holds the title of being the third electrically-lit city in the world, which took place on February 2, 1880. Four 3,000 candle power Brush arc lamps suspended over the courthouse rendered the town square "as light midday," Kimberly, South Africa, was the first city in Africa to have electric lights – first lit on 1 September 1882. In Latin America, San Jose, Costa Rica was the first city, the system was launched on August 9, 1884, with 25 lamps powered by an hydro electric plant.

### **1.3 STATEMENT OF PROBLEM**

As explained in section 1.1, the importance of street light is a major topic to consider by any developing community if it is to achieve its economic goals and objectives. Most cities understand this and in effect strive by all means to illuminate their streets. However due to factors such as such as lack of proper design, use of wrong materials, improper power supply

network, etc, they have not been able to construct reliable street lights. This has lead to several problems such as:

1. Increase in accident rates as some vehicles lack source of illumination at night.
2. Loss of lives and property
3. Encouragement of crime and vandalism. Criminals are more comfortable in committing crimes when they feel invisible
4. Making residents feel unsecure. Pedestrians and residents of streets cannot feel safe when their streets are completely dark.
5. Making the aesthetic quality of the area unknown to viewers at night
6. Reducing the standard of living of residents as there will be a decline in the community's growth and development

A proper design layout and an effective construction of streetlights will solve the problems above.

#### **1.4 AIMS AND OBJECTIVES**

The primary aim of this project is to employ the most efficient illumination technique to design street light arrangement for a 5km road which can always serve as a guide for contractors that desire a most reliable street lighting.

It is also aimed at using the most efficient and effective wiring technique, the most accurate approach for calculating load requirement and in turn the most reliable fusing systems to also help street light contractors construct a lasting street light arrangement and reduce the over-all cost of construction of street light.



## **1.5 PROJECT MOTIVATION**

The sole importance of engineering is the production of the most efficient and effective system with the use of the least amount of resources and avoiding as much as possible, waste. It is desired in engineering that cost and reliability be taken into consideration in any process of design and implementation. Most developing and under-developing countries aspire to attain a level of economic growth and development that will improve the over-all standard of living of their citizens. The only way to achieve this goal is to increase productivity, net profit and putting to full utility the available resources. Unfortunately, most of these countries lack the necessary resources and man power to do this and thus are forced to use the little available resources to build outstanding infra-structures, good road networks and comfortable business atmosphere as a way of inviting potential investors. All these structures cannot effectively serve their purpose if they are not properly illuminated at night. It is even more unfortunate that these countries realize the need for street lighting but have failed in constructing reliable and cost efficient ones because the contractors base their work on inaccurate designs.

To solve this problem hindering growth and development of major cities, engineers are required to design a more reliable and an efficient street light arrangement.

## **1.6 SCOPE OF PROJECT**

The project will require a proper understanding of two aspects of engineering. The first is a detail understanding of Illumination Engineering and secondly, proper understandings of power supply network design. It will also require a major understanding of the operating principle and conditions of the mercury vapor lamp as it will be used in the design.

## **1.7 LIMITATION OF PROJECT**

The project design is limited to a road extending 5km only. In most cases, actual constructions are made for road extending over hundreds of kilometers. lighting devices used is also limited to mercury vapor lamp which in some cases may be too expensive to use and will require an alternative device.

# CHAPTER TWO

## THE THEORY OF DESIGN

### 2.1 SITE DESCRIPTION

For this project work, the dimension of the road is 5km (5000m) in length and width of the road 8m.

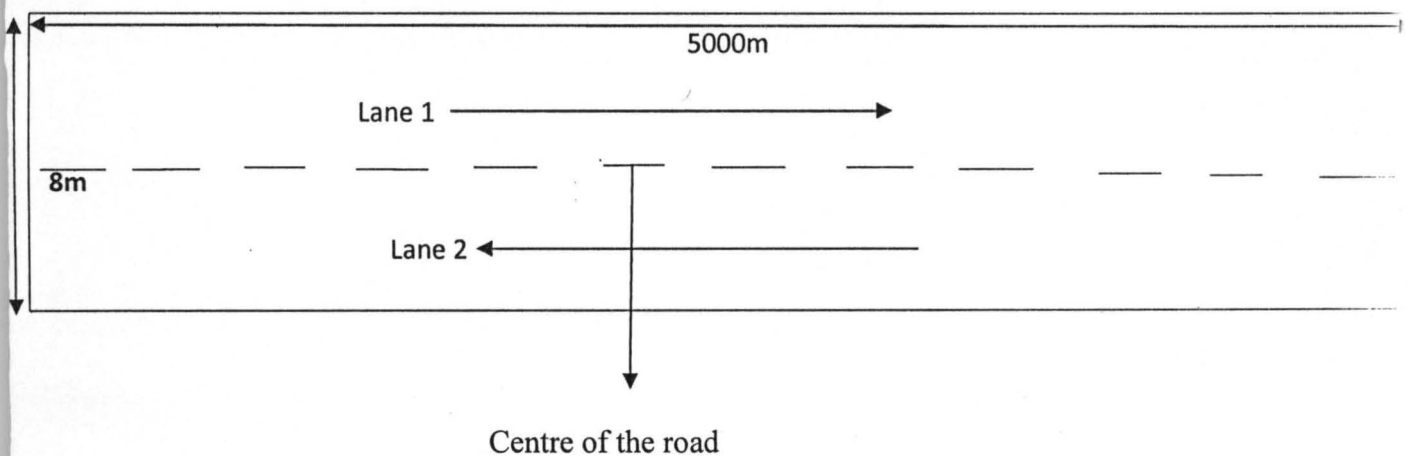

Figure 2.1 a two lane road

### 2.2 POWER DISTRIBUTION

Is the final stage in delivery (before retail) of electricity to end users. A distribution system's network carries electricity from the transmission system and delivers it to consumers. Typically, the network will include medium-voltage (less than 50KV) power lines, electrical substations and pole-mounted transformers, low-voltage (less than 1 KV) distribution wiring and sometimes electricity meters.

For the purpose of this project emphasis will be given to the Distribution system. PHCN- Power Holding Company of Nigeria is the agency of the Government responsible for Generation,

transmission and distribution of electricity in Nigeria. PHCN distributes power using the grid system.

PHCN'S National grid control center is at Oshogbo in Osun State of Nigeria. This center controls every other transmission and power station linked to the grid in the country. fig. 2.2 show the schematic illustration of distribution of electricity from power stations transformers, transmission lines and to individuals

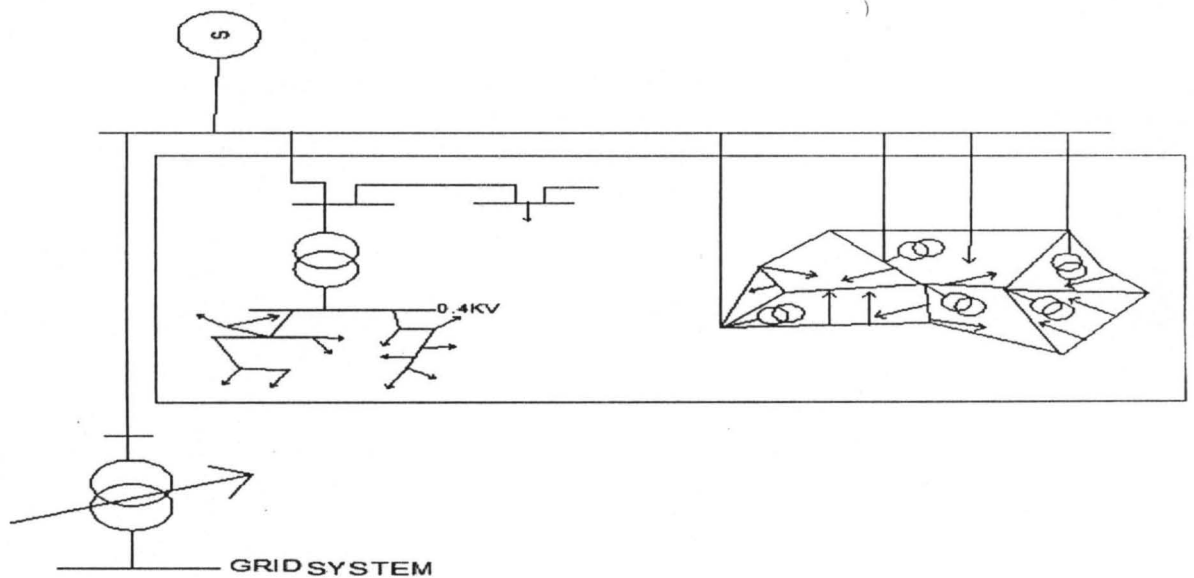

*Fig. 2.2 Single stage distribution.*

It involves the stepping down of voltage from 6-20KV to 400V, which can feed directly commercial or domestic consumers. Fig.2.3 involves three stages distribution i.e. stepping down from 132-330KV to 33KV as stage 1, then stepping down from 33KV to 6-20KV as stage 2 and finally stepping down from 6-20KV to 400/230KV as stage 3.

As said earlier on, Power station generators are produced to work between 6-20KV for economic reasons. For further transmission the generated voltage is stepped up to 132-330KV for long distant transmission as shown in the fig.2.3.

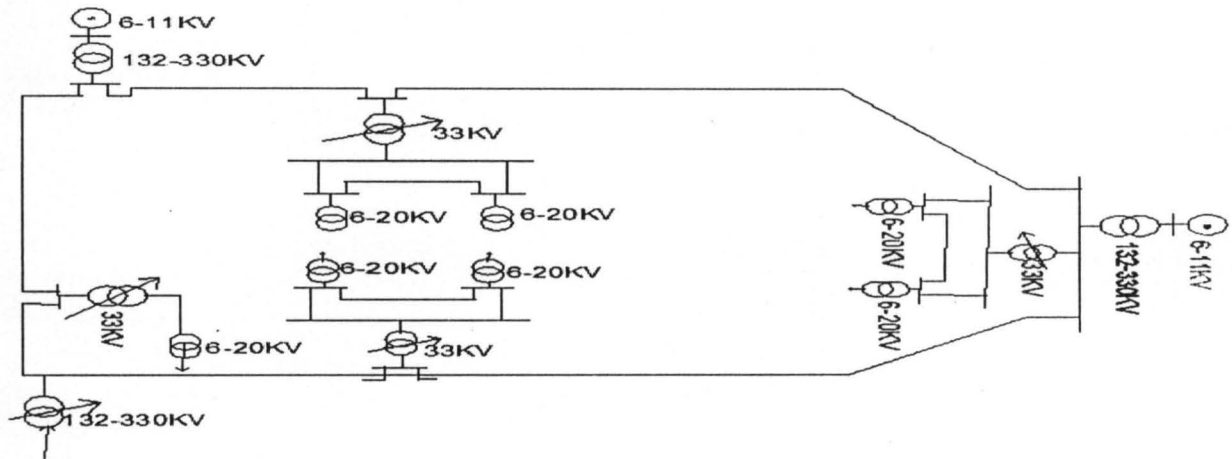

Fig. 2.3 Three stages distribution.

## 2.2.1 INCOMING SERVICE CABLE

The incoming supply enters via the supply authority (PHCN) equipment to the main switch of the “link type” (i.e. a switch which breaks both poles of the supply). From the main switch, the supply is fed to a distribution board containing fuses or other suitable overload protection equipment.

## 2.2.2 FINAL SUB-CIRCUITS

Is the last electric junction after a proper junction in an electrical installation. After that circuit the whole electric circuit is complete.

The cables normally used for final circuits are  $1.5\text{mm}^2$ ,  $2.5\text{mm}^2$  and  $6.0\text{mm}^2$ , according to the nature of the circuit. Lighting is almost invariably carried out in  $1.5\text{mm}^2$  cable

and power circuits to socket outlets in 2.5mm<sup>2</sup>, 6.0mm<sup>2</sup> and 10mm<sup>2</sup> cables is used for circuits to cookers, instantaneous water heaters, showers, and other large current-using equipment, such as machine tools in workshops.

The I.E.E Regulation has definite rules guiding final sub-circuits. The rules are necessary to ensure that wiring to sub-circuits and fuse protection is such that danger is prevented and satisfactory results are obtained.

Final sub-circuit is in the following categories:

- i. A sub-circuit with a rated capacity not exceeding 15A.
- ii. A sub-circuit with a rated capacity exceeding 15A.
- iii. A sub-circuit feeding 13A fused plugs.
- iv. A sub-circuit feeding fluorescent and other types of electric discharge lighting.
- v. A sub-circuit feeding a motor or rotating electrical machine.

The I.E.E Regulation stipulates that for a final sub-circuit of rating not exceeding 15A, the number of point that may be supplied is limited by their aggregate demand as determined. There must be no allowance for diversity. The current rating of the cable must not be exceeded.

Some final sub-circuits are connected directly to the distribution board while a sub-main can also be used to supply a further sub-distribution board to which other final sub-circuit is connected.

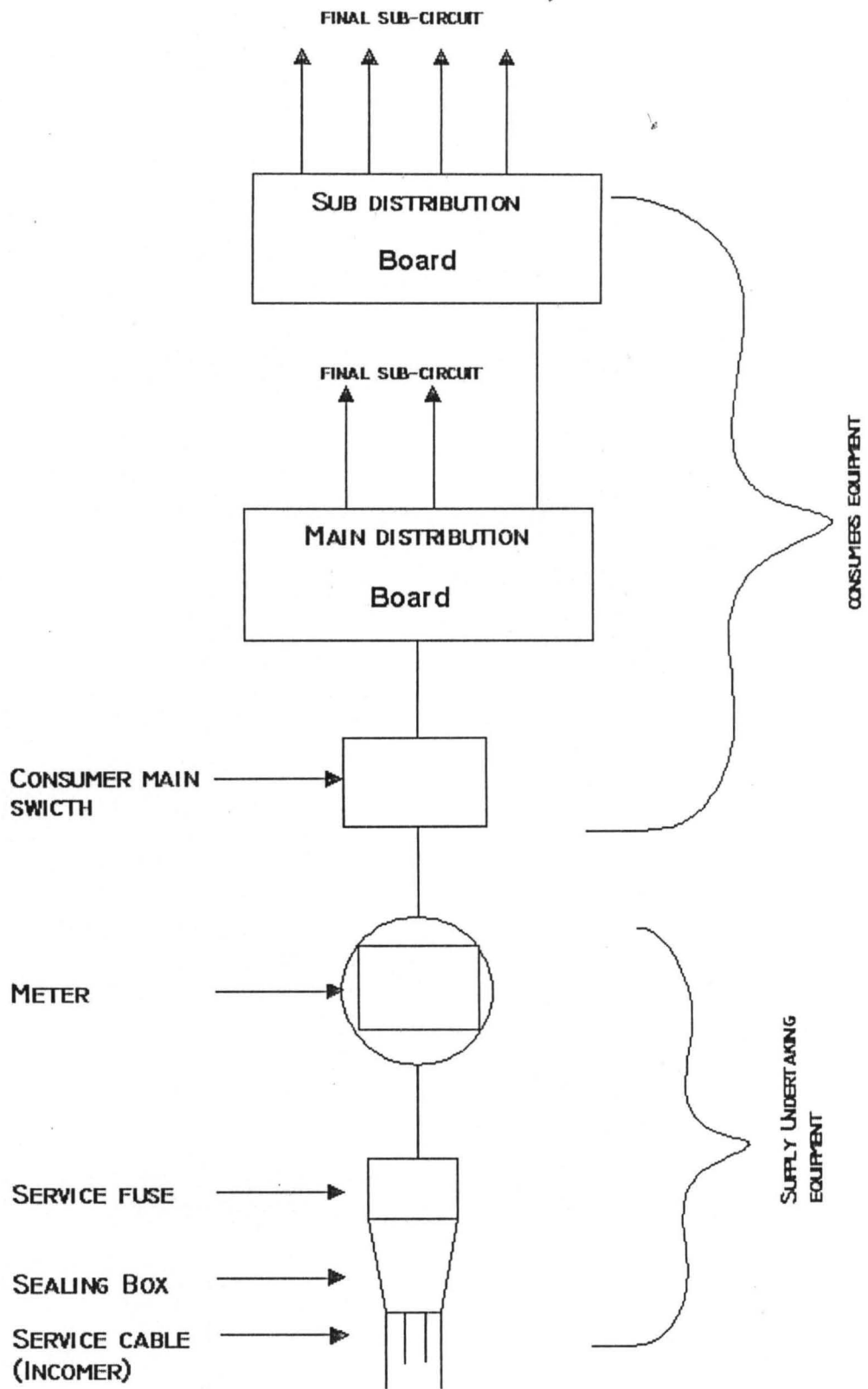

Figure 2.4 Sequence of supply controls

## **2.3 CABLES**

A cable is two or more wires running side by side and bonded, twisted or braided together to form a single assembly. In Electric Engineering cables are used to carry electric current. Electric cables discussed here are mainly meant for installation in buildings and industrial sites. For power transmission at distance greater than few kilometers i.e high voltage cable, power cables and HVDC.

Cables are perhaps the most important element in any electrical installation. They are the means which power is transmitted at a high voltage or current delivered to an appliance or equipment, the final consumption point.

The necessary requirement stipulated by the IEE regulation and the British standards rules of cables is that:

1. Cables should conduct electricity efficiently, cheaply and safely.
2. To this end, cable should not be too small so as to have a large internal voltage drop or too big to reduce cost.
3. Cable insulation should be such as to prevent leakage of current and minimize risk of electric shock.

### **2.3.1 Cable categories**

Cables could be categorized according to their method of use, such as:

- (i) Underground cables.
- (ii) Overhead cables.

### **2.3.2 Uderground cables**



This refers to the type of electric power cable installed in underground ducts which is extensively used in cities where lack of space or considerations of safety preclude the use of overhead lines. Unlike an aerial cable, a buried cable invariably uses commercially pure copper or aluminum (mechanical strength is not a problem underground).

The types of underground cables are:

- i. T.C. cable P.J. filled unarmoured P.E. Insulated P.E sheathed aluminum screen (Application in ducts only).
- ii. TC cable (PFA) P/E. insulated P.E sheathed copper cable with aluminum. Screen steel wire 10pairs---800pairs.
- iii. PVC insulated PVC sheathed armoured 600/1000v.  $1.5\text{mm}^2$ --- $630\text{mm}^2$ .

### 2.3.3 Overhead cables

These are cables use for the supply of electric power, laid on utility poles. The types are:

- i. Aluminum conductors steel reinforced  $150\text{mm}^2$  AL 30/22.59mm; steel 7/2 59 (application in transmission system).
- ii.  $100\text{mm}^2$  (19/2.67mm $\varnothing$ ) all aluminum stranded conductor (application in distribution system).
- iii.  $70\text{mm}^2$  all aluminum strand PVC insulated PVC sheathed (application in domestic power supply and street light.)

**BASIC FACTORS:** The IEE regulation stipulated that all cables carrying current must be so selected as to be able to carry their rated currents, without deterioration.

This is why in choosing cables; two factors have to be born in mind via:

- (1) The current carrying capacity of a cable.

- (2) The voltage drop along the cable.

## **2.4 PROTECTION**

This is defined as the process by which possible dangers arising from electrical installation works are being prevented.

The dangers are classified as:

- (i) Overload current.
- (ii) Short circuit current.
- (iii) Earth leakage current.

In an electrical wiring system, when the above dangers are not minimized or totally prevented, the consequences may be disastrous and costly and may even involve lives of users.

The I.E.E Regulation of 14<sup>th</sup> Edition in section A and D stipulates the necessary requirements to avert dangers arising from electrical installation works.

Therefore the need for adequate electrical installation work cannot be over emphasized.

### **2.4.1 Methods of protection**

- a. Rewirable fuses (semi-enclosed fuses)
- b. H.R.C (High Rupturing Capacity) fuse
- c. M.C.B (Miniature Circuit Breaker) (BS 3871)
- d. E.L.C.B (Earth Leakage Circuit Breaker)

### **2.4.2 Earthing**

When insulation materials become damages or if wire becomes displaced any metal work directly in contact with the electrical wiring system could become live. If such metal is touched

there could be serious electric shock. Earthing of metal work prevents the risk of shock so that a heavy current flows to earth.

IEE regulation stipulates that every means of earthing and every protective conductor shall be selected and erected so as to satisfy the requirements of these regulations for the safety and proper functioning of the associated equipment of the installation.

The reason for earthing being among others is for:

- a. Personal protection
- b. Equipment protection
- c. Correct functioning of equipment
- d. Reliability of electrical services

A good connection to earth should have a low electrical resistance, good corrosion resistance, ability to carry high current repeatedly and ability to perform above functions over a long period of time. Some factors exist which affect a good earthing system and these must be considered always. These include:

The soil types, moisture content and earth temperature. The IEE regulation and British standard codes thus recommend the following earth electrodes for installation.

- a. Earth rods or pipes.
- b. Earth tapes or wires.
- c. Earth plates.
- d. Earth electrodes embedded in foundation.
- e. Metallic reinforcement of concrete.
- f. Metallic pipe.

- g. Lead sheaths.

### **2.4.3 Methods of earthing**

The IEE regulation states that every installation must have earth cables which are wires normally  $2.5\text{mm}^2$  (minimum) cross sectional area. The earthing wires must be so fixed to the installation such as water, gas, lighting system. It recommends the following methods of earthing:

- a. Deep driven earth rod electrodes
- b. Parallel driven earth rod
- c. Buried conductors
- d. Buried earth plates or mats

## **2.5 TRANSFORMER**

A transformer is a device that transfers electrical energy from one circuit to another through inductively coupled conductors the transformer's coils. A varying current in the first or primary winding creates a varying magnetic flux in the transformer's core, and thus a varying magnetic field through the secondary winding. This varying magnetic field induces a varying electromotive force (EMF) or "voltage" in the secondary winding. This effect is called mutual induction.

### **2.5.1 Basic principle of operation**

The transformer is based on two principles: firstly, that an electric current can produce a magnetic field (electromagnetism), and, secondly that a changing magnetic field

within a coil of wire induces a voltage across the ends of the coil (electromagnetic induction). Changing the current in the primary coil changes the magnetic flux that is developed. The changing magnetic flux induces a voltage in the secondary coil.

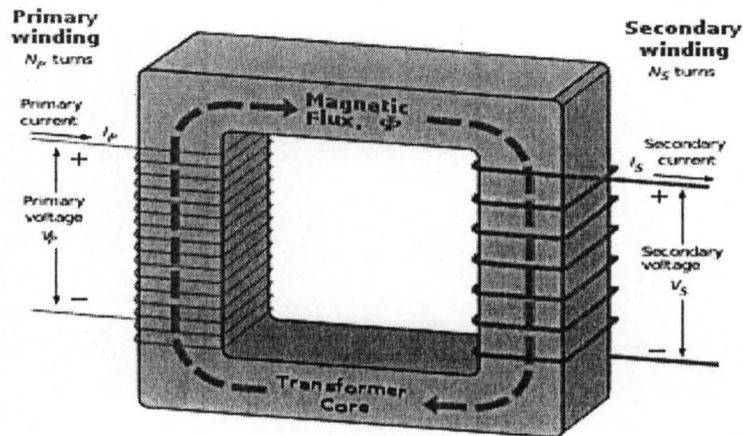

Fig. 2.5 an ideal transformer

An ideal transformer is shown in figure 2.5. Current passing through the primary coil creates a magnetic field. The primary and secondary coils are wrapped around a core of very high magnetic permeability, such as iron, so that most of the magnetic flux passes through both the primary and secondary coils.

The transformer can be categorized as:

- (i) Step-down transformer.
- (ii) Step-up transformer.

For this project, a step-down transformer which will step-down voltage from 33/11kv to 400v will be used.

### **2.5.2 Feeder pillars**

Feeder pillars are mainly used for housing or installing various equipments or street lighting units. Low-voltage feeder pillars form a basic part of most public and man private distribution networks. Feeder pillars are connected to the distribution board

Feeder pillars are usually made of strong and weather proof materials. Some of materials used to make feeder pillars include:

- (i) Galvanised sheet steel
- (ii) Stainless steel

## **2.6 METALLIC POLE**

These are steel columns with diameters ranging from 100mm to 150mm and height 10m to 30m that floodlights are mounted upon.

### **2.6.1 Pole discription**

- The poles are designed in accordance with ILE TR7.
- They are hot dip galvanized after fabrication in accordance with BS EN ISO 1461, subsequent painting might follow.

## **2.7 LIGHTING**

Lighting or illumination is the deliberate application of light to achieve some aesthetic or practical effect. Lighting includes use of both artificial light sources such as lamps and natural illumination of interiors from daylight. Day lighting (through windows, skylights, etc.) is often used as the main source of light during daytime in buildings given its low cost. Artificial lighting

represents a major component of energy consumption, accounting for a significant part of all energy consumed worldwide. Artificial lighting is most commonly provided today by electric lights, but gas lighting, candles, or oil lamps were used in the past, and still are used in certain situations. Proper lighting can enhance task performance or aesthetics, while there can be energy wastage and adverse health effects of poorly designed lighting. Indoor lighting is a form of fixture or furnishing, and a key part of interior design. Lighting can also be an intrinsic component of landscaping.

Lighting may also be defined as the application of visible radiation to an object so as to cause a direct visible radiation. The human eye relies on lighting to effectively see physical objects. Images of objects cannot be focused onto its retina if they are not properly illuminated.

### **2.7.1 Lighting Fixtures**

A light fixture is anything that is capable of radiating light in form of radiant energy. It is common for most light sources to be a source of heat. Nearly any material can be used, so long as it can tolerate the excess heat and is in keeping with safety codes. Some of the common materials used are;

- (1) Electricity: this is the most diverse source of light source employed for artificial lighting. It relies on the fact that when electric current is passed through some materials, they generate heat as well as light energy.
- (2) Fire: this is the earliest source of light and relies solely on the burning of flammable materials such as wood, paper, candles, etc to produce light energy.
- (3) Sun: this is the primary source of light for natural lighting. It is a heavenly body producing light and heat energy to the surface of the earth.

- (4) Moon: the moon is also a heavenly body but relies on the principle of light reflection to produce light. It does this by reflecting the sun's light at night and using it to illuminate the earth.

### **2.7.2 Types of lighting**

Lighting is classified by intended use as general, localized, or task lighting, depending largely on the distribution of the light produced by the fixture. There are three major classes on the basis explained above:

- (1) Task lighting is mainly functional and is usually the most concentrated, for purposes such as reading or inspection of materials. For example, reading poor-quality reproductions may require task lighting levels up to 1500 lux and some inspection tasks or surgical procedures require even higher levels.
- (2) Accent lighting is mainly decorative, intended to highlight pictures, plants, or other elements of interior design or landscaping.
- (3) General lighting (sometimes referred to as ambient light) fills in between the two and is intended for general illumination of an area. Indoors, this would be a basic lamp on a table or floor, or a fixture on the ceiling. Outdoors, general lighting for a parking lot may be as low as 10-20 lux since pedestrians and motorists already used to the dark will need little light for crossing the area.

### **2.7.3 Methods of lighting**

In any lighting installation, it is desired to direct a considerable amount of the light to the working plane. This has led to the several methods of lighting available, some of which are:



- (1) Down lighting: this is most common, with fixtures on or recessed in the ceiling casting light downward. This tends to be the most used method, used in both offices and homes. Although it is easy to design it has dramatic problems with glare and excess energy consumption due to large number of fittings.
- (2) Up lighting: is less common, often used to bounce indirect light off the ceiling and back down. It is commonly used in lighting applications that require minimal glare and uniform general illuminance levels. Up lighting (indirect) uses a diffuse surface to reflect light in a space and can minimize disabling glare on computer displays and other dark glossy surfaces. It gives a more uniform presentation of the light output in operation. However indirect lighting is completely reliant upon the reflectance value of the surface. While indirect lighting can create a diffused and shadow free light effect it can be regarded as an uneconomical lighting principle.
- (3) Front lighting: is also quite common, but tends to make the subject look flat as it casts almost no visible shadows. Lighting from the side is the less common, as it tends to produce glare near eye level. Backlighting either around or through an object is mainly for accent.

#### **2.7.4 Forms of lighting**

This is classifying light on the basis of environment. Some of the forms of lighting are clearly explained below. The two basic forms of lighting include the indoor lighting and the outdoor lighting.

- (1) Indoor lighting:
- (2) Outdoor lighting:

### 2.7.5 Lighting installation

In attempt to increase the efficiency and reliability of light sources used in both indoor and outdoor lighting for artificial lighting, several devises have been invented over time. Some proved more efficient than the others and as such ruled out their usage. However each of them has a unique advantage over the others which can only be understood by clearly studying their principle of operation. They include:

- (1) The Tungsten filament lamp
- (2) The Tungsten halogen lamp
- (3) The fluorescent lamp
- (4) The mercury vapor lamp
- (5) The sodium lamps

The principle of operation of each of them has been well explained below;

**(i) Principle of operation of the Tungsten filament lamp:** tungsten filament lamp also called the incandescent lamp consists of a thin filament of tungsten inside an evacuated glass tube. The tungsten filament is a material that increases its temperature with the increase in current passed through it. At a well enough temperature below its melting point ( $3382^{\circ}\text{C}$ ) it generates heat energy as well as light energy. This is what the lamp bases its principle of operation on. The filament will continue to emit light provided it does not reach its melting point. To prevent the filament from oxidizing, it is completely evacuated of air. A common problem of the tungsten evaporating and blackening the inside of the bulb is tackled by filling the bulb with an inert gas (a mixture of 93% argon and 7% nitrogen). The diagram below shows the tungsten filament bulb.

Incandescent bulbs are made in a wide range of sizes and voltages, from 1.5 volts to about 300 volts. They require no external regulating equipment and have a low manufacturing cost, and work well on either alternating current or direct current. As a result the incandescent lamp is widely used in household and commercial lighting, for portable lighting such as table lamps, car headlamps, and flashlights, and for decorative and advertising lighting.

Some applications of the incandescent bulb make use of the heat generated, such as incubators, brooding boxes for poultry, heat lights for reptile tanks, infrared heating for industrial heating and drying processes, and the Easy-Bake Oven toy. In cold weather the heat shed by incandescent lamps contributes to building heating, but in hot climates lamp losses increase the energy used by air conditioning systems.

Incandescent light bulbs are gradually being replaced in many applications by other types of electric light such as (compact) fluorescent lamps, high-intensity discharge lamps, light-emitting diodes (LEDs), and other devices.

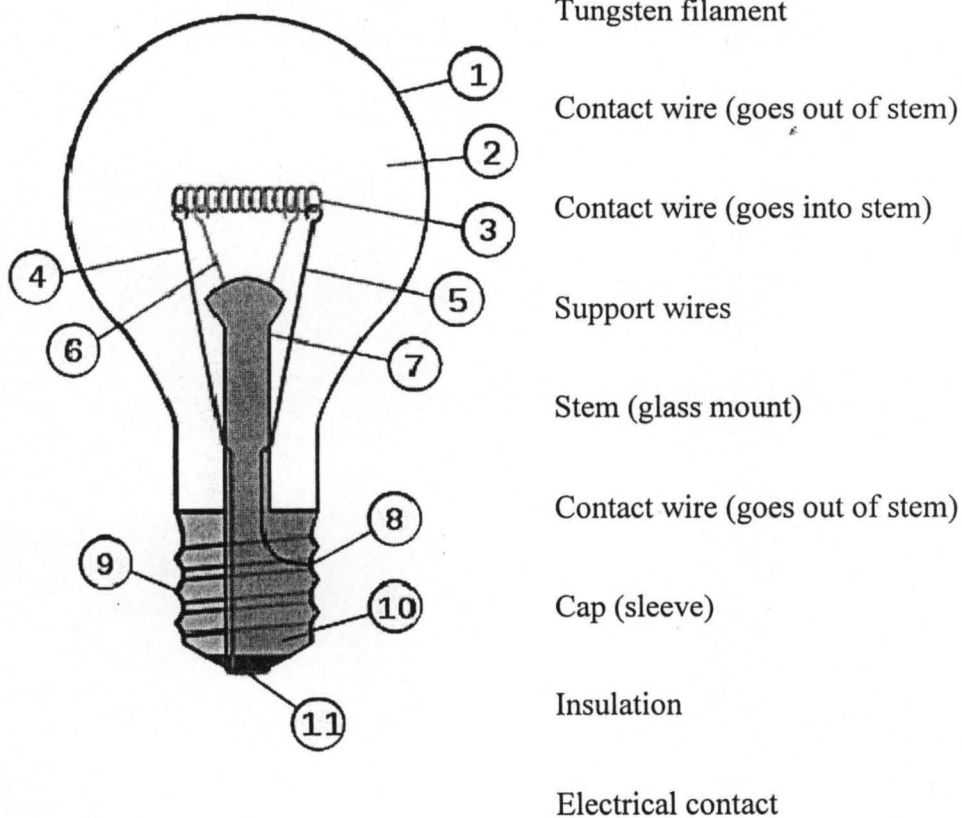

Fig 2.6 Tungsten filament lamp; Low pressure inert gas (argon, neon, nitrogen)

**(ii) Principle of operation of the Tungsten halogen lamp:** A halogen lamp is an incandescent lamp with a tungsten filament contained within an inert gas and a small amount of a halogen such as iodine or bromine. The combination of the halogen gas and the tungsten filament produces a chemical reaction known as a halogen cycle (see below) that increases the lifetime of the bulb and prevents its darkening by re-depositing tungsten from the inside of the bulb back onto the filament. The halogen lamp can operate its filament at a higher temperature than a standard gas filled lamp of similar power without loss of operating life. This gives it a higher efficacy (10–30 lm/W). It also gives light of a higher color temperature compared to a non-

halogen incandescent lamp. Alternatively, it may be designed to have perhaps twice the life with the same or slightly higher efficacy. Because of their smaller size, halogen lamps can advantageously be used with optical systems that are more efficient.

The function of the halogen is to set up a reversible chemical reaction with the tungsten evaporating from the filament. In ordinary incandescent lamps, this tungsten is mostly deposited on the bulb. The halogen cycle keeps the bulb clean and the light output remains almost constant throughout life. At moderate temperatures the halogen reacts with the evaporating tungsten, the halide formed being moved around in the inert gas filling. At some time it will reach higher temperature regions, where it dissociates, releasing tungsten and freeing the halogen to repeat the process. In order for the reaction to operate, the overall bulb temperature must be higher than in conventional incandescent lamps. The bulb must be made of fused silica (quartz) or a high melting point glass (such as aluminosilicate glass). Below is a well labeled diagram of a typical tungsten halogen lamp.

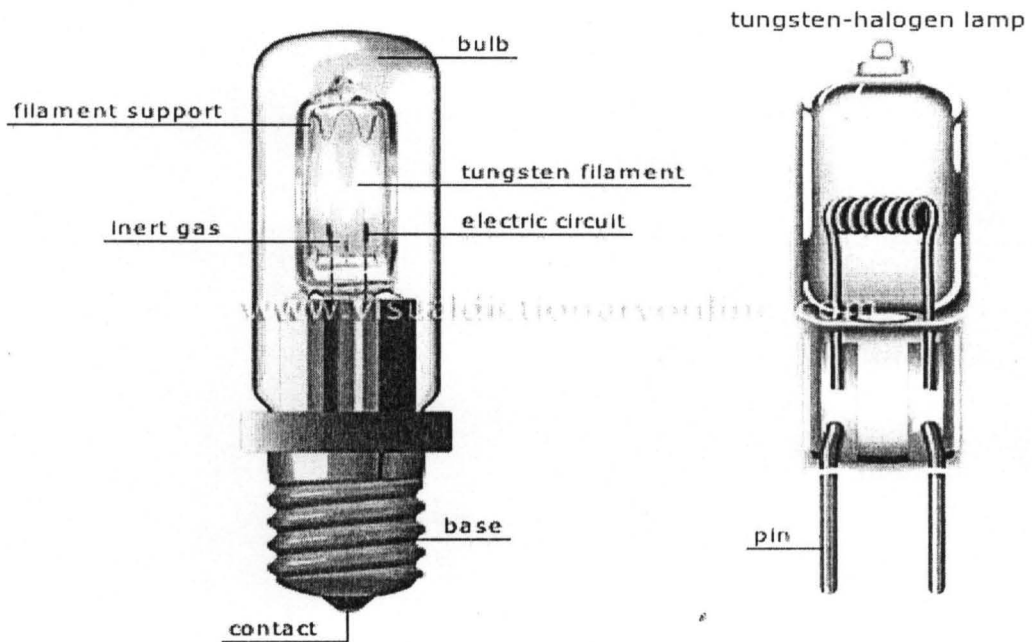

Fig 2.7 Tungsten halogen lamp

**(iii) Principle of operation of the Fluorescent lamp:** A fluorescent lamp or fluorescent tube is a gas-discharge lamp that uses electricity to excite mercury vapor. The excited mercury atoms produce short-wave ultraviolet light that then causes a phosphor to fluoresce, producing visible light. A fluorescent lamp converts electrical power into useful light more efficiently than an incandescent lamp. Lower energy cost typically offsets the higher initial cost of the lamp. The lamp is more costly because it requires a ballast to regulate the flow of current through the lamp.

While larger fluorescent lamps have been mostly used in commercial or institutional buildings, the compact fluorescent lamp is now available in the same popular sizes as incandescent lamps and is used as an energy-saving alternative in homes.

The mercury atoms in the fluorescent tube must be ionized before the arc can "strike" within the tube. For small lamps, it does not take much voltage to strike the arc and starting the lamp presents no problem, but larger tubes require a substantial voltage (in the range of a thousand volts). There are several methods employed in starting a fluorescent lamp to the effect above and the figure below shows the automatic starting switch

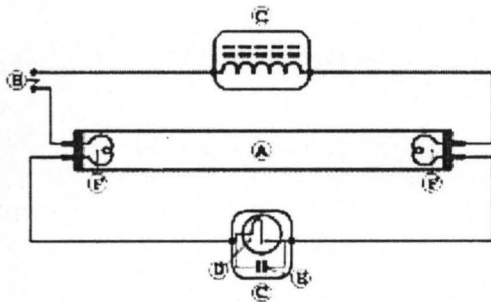

Fig 2.8 Starting the fluorescent lamp

(iii) **Principle of operation of Mercury Vapor Lamp:** The mercury vapour lamp is a negative resistance device and requires a ballast) to prevent it from taking excessive current. The auxiliary components are substantially similar to the ballasts used with fluorescent lamps. Also like fluorescent lamps, mercury vapour lamps usually require a starter, which is usually contained within the mercury vapour lamp itself. A third electrode is mounted near one of the main electrodes and connected through a resistor to the other main electrode. When power is applied, there is sufficient voltage to strike an arc between the starting electrode and the adjacent main electrode. This arc discharge eventually provides enough ionized mercury to strike an arc between the main electrodes. Occasionally, a thermal switch will also be installed to short the starting electrode to the adjacent main electrode, completely suppressing the starting arc once the main arc strikes. For this project work, mercury vapour lamp will be used.

**Description:** Mercury vapour lamps are bright, long-lasting light sources that are often used to light large areas such as streets, gyms, sports arenas, banks, or stores. The bulbs have an inner quartz tube containing the mercury vapour discharge. This is enclosed by an outer glass bulb that filters out harmful short-wavelength ultraviolet radiation (UV). The figure below shows a mercury vapour lamp.

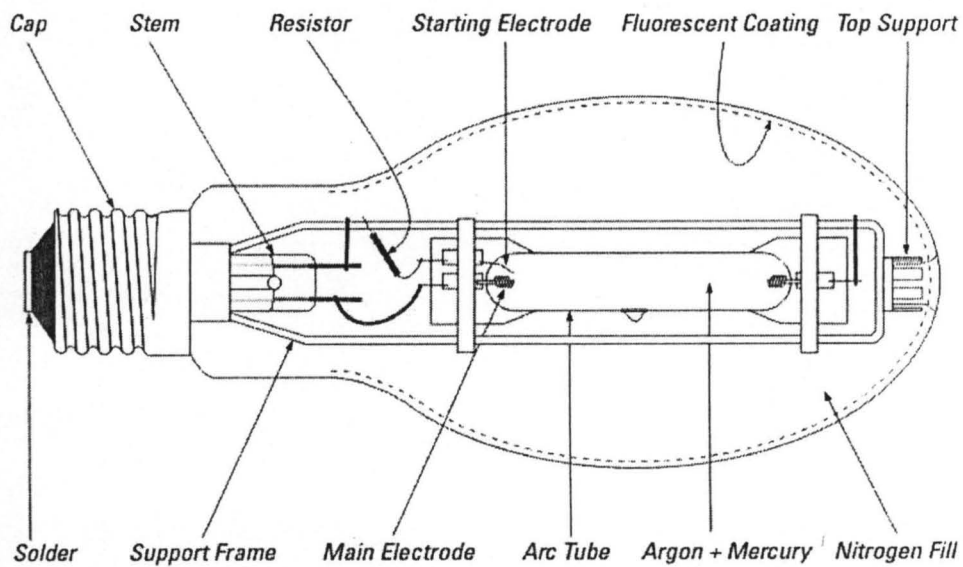

Fig 2.9 Mercury vapor lamp

**(v) Principle of operation of the Sodium vapor lamp:** A Sodium vapor lamp is a gas discharge lamp which uses sodium in an excited state to produce light. There are two varieties of such lamps: *low pressure* and *high pressure*. Because sodium vapor lamps cause less light pollution than mercury-vapor lamps, many cities that have large astronomical observatories employ them.

Low-pressure sodium (LPS) lamps have a borosilicate glass gas discharge tube (arc tube) containing solid sodium and a small amount of neon and argon gas Penning mixture to start the gas discharge. The discharge tube may be linear (SLI lamp) or U-shaped. When the lamp is



turned on it emits a dim red/pink light to warm the sodium metal and within a few minutes it turns into the common bright yellow as the sodium metal vaporizes. These lamps produce a virtually monochromatic light averaging at a 589.3 nm wavelength (actually two dominant spectral lines very close together at 589.0 and 589.6 nm). As a result, the colors of illuminated objects are not easily distinguished since they are seen almost entirely by their reflection of this narrow bandwidth yellow light.

High-pressure sodium (HPS) lamps are smaller and contain additional elements such as mercury, and produce a dark pink glow when first struck, and a pinkish orange light when warmed. Some bulbs also briefly produce a pure to bluish white light in between. This is probably from the mercury glowing before the sodium is completely warmed. The sodium D-line is the main source of light from the HPS lamp, and it is extremely pressure broadened by the high sodium pressures in the lamp; due to this broadening and the emissions from mercury, colors of objects under these lamps can be distinguished. This leads them to be used in areas where good color rendering is important, or desired. Thus, its new model name SON is the variant for "sun" (a name used primarily in Europe and the UK). HPS Lamps are favored by indoor gardeners for general growing because of the wide color-temperature spectrum produced and the relatively efficient cost of running the lights. The figure below illustrates the simple principle of operation of the sodium vapor lamp.

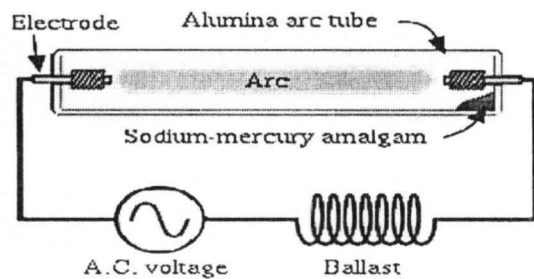

Fig 2.10 the Sodium vapor lamp

## 2.8 ILLUMINATION

Simply put, illumination is the application of visible radiation to an object. This is made possible with the help of light energy which is a form of radiation capable of causing a direct visual sensation. The aspect of engineering that deals with the study of the different ways of effectively illuminating objects to bring out their qualities is known as illumination engineering. In this section of the chapter, the different steps taken to produce a desired level of illumination will be discussed. The different mathematical formula used in illumination engineering will also be stated and the parameters well explained.

### 2.8.1 Basic terms used in Illumination engineering

(1) **Luminance:** Luminance is a photometric measure of the luminous intensity per unit area of light travelling in a given direction. It describes the amount of light that passes through or is emitted from a particular area, and falls within a given solid angle. The SI unit for luminance is candela per square meter ( $\text{cd}/\text{m}^2$ ). A non-SI term for the same unit is the "nit". The CGS unit of luminance is the stilb, which is equal to one candela per square centimeter or  $10 \text{ kcd}/\text{m}^2$ .

Luminance is often used to characterize emission or reflection from flat, diffuse surfaces. The luminance indicates how much luminous power will be perceived by an eye looking at the surface from a particular angle of view. Luminance is thus an indicator of how bright the surface will appear. In this case, the solid angle of interest is the solid angle subtended by the eye's pupil. Luminance is used in the video industry to characterize the brightness of displays. A typical computer display emits between 50 and  $300 \text{ cd}/\text{m}^2$ . The sun has luminance of about  $1.6 \times 10^9 \text{ cd}/\text{m}^2$  at noon.

Luminance is invariant in geometric optics. This means that for an ideal optical system, the luminance at the output is the same as the input luminance. For real, passive, optical systems, the output luminance is at most equal to the input. As an example, if you form a de-magnified image with a lens, the luminous power is concentrated into a smaller area, meaning that the illuminance is higher at the image. The light at the image plane, however, fills a larger solid angle so the luminance comes out to be the same assuming there is no loss at the lens. The image can never be "brighter" than the source.

Mathematically, it is defined as

$$L_v = \frac{d^2F}{dA d\Omega \cos \theta}$$

Where

$L_v$  is the luminance (cd/m<sup>2</sup>),

$F$  is the luminous flux or luminous power (lm),

$\theta$  is the angle between the surface normal and the specified direction,

$A$  is the area of the surface (m<sup>2</sup>), and  $\Omega$  is the solid angle (sr).

**(2) Illuminance:** Illuminance is the total luminous flux incident on a surface, per unit area. It is a measure of the intensity of the incident light, wavelength-weighted by the luminosity function to correlate with human brightness perception.

In SI derived units, it is measured in lux (lx) or lumens per square metre ( $\text{cd}\cdot\text{sr}\cdot\text{m}^{-2}$ ). In the CGS system, the unit of illuminance is the phot. One phot is equal to 10,000 lux. The foot-candle is a non-metric unit of illuminance that is used in photography.

Illuminance was formerly often called brightness, but this leads to confusion with other uses of the word. "Brightness" should never be used for quantitative description, but only for non quantitative references to physiological sensations and perceptions of light.

**(3) Luminous energy:** luminous energy is the perceived energy of light. This is sometimes also called the quantity of light. Luminous energy is not the same as the radiant energy, the corresponding objective physical quantity. This is because the human eye can only see light in the visible spectrum and has different sensitivities to light of different wavelengths within the spectrum. When adapted for bright conditions (photopic vision), the eye is most sensitive to light at a wavelength of 555 nm. Light with the same power at longer or shorter wavelengths has a lower luminous energy. The SI unit of luminous energy is the lumen second, which is unofficially known as the Talbot in honor of William Henry Fox Talbot. In other systems of units, luminous energy may be expressed in basic units of energy.

**(4) Luminous flux:** In photometry, luminous flux or luminous power is the measure of the perceived power of light. It differs from radiant flux, the measure of the total power of light emitted, in that luminous flux is adjusted to reflect the varying sensitivity of the human eye to different wavelengths of light. The SI unit of luminous flux is the lumen (lm). One lumen is defined as the luminous flux of light produced by a light source that emits one candela of luminous intensity over a solid angle of one steradian. In other systems of units, luminous flux may have units of power [9].

**(5) Luminous intensity:** luminous intensity is a measure of the wavelength-weighted power emitted by a light source in a particular direction per unit solid angle, based on the luminosity function, a standardized model of the sensitivity of the human eye. The SI unit of luminous intensity is the candela (cd), an SI base unit.

Photometry deals with the measurement of visible light as perceived by human eyes. The human eye can only see light in the visible spectrum and has different sensitivities to light of different wavelengths within the spectrum. When adapted for bright conditions (photopic vision), the eye is most sensitive to greenish-yellow light at 555 nm. Light with the same radiant intensity at other wavelengths has a lower luminous intensity. The curve which measures the response of the human eye to light is a defined standard, known as the luminosity function. This curve, denoted  $V(\lambda)$  or  $\bar{y}(\lambda)$ , is based on an average of widely differing experimental data from scientists using different measurement techniques. For instance, the measured responses of the eye to violet light varied by a factor of ten.

Luminous intensity should not be confused with another photometric unit, luminous flux, which is the total perceived power emitted in all directions. Luminous intensity is the perceived power per unit solid angle. Luminous intensity is also not the same as the radiant intensity, the corresponding objective physical quantity used in the measurement science of radiometry.

**(6) Luminous emittance:** luminous emittance is the luminous flux per unit area emitted from a surface. Luminous emittance is also known as luminous exitance.

**(7) Luminous efficacy:** Luminous efficacy is a figure of merit for light sources. It is the ratio of luminous flux (in lumens) to power (usually measured in watts). Depending on context,

the power can be either the radiant flux of the source's output, or it can be the total electric power consumed by the source. Which sense of the term is intended must usually be inferred from the context, and is sometimes unclear. The former sense is sometimes called luminous efficacy of radiation (LER), and the latter luminous efficacy of a source (LES).

The dimensionless luminous efficiency measures the integrated fraction of the radiant power that contributes to its luminous properties as evaluated by means of the standard luminosity function.

The luminous coefficient is

$$\frac{\int_0^{\infty} y_{\lambda} J_{\lambda} d\lambda}{\int_0^{\infty} J_{\lambda} d\lambda},$$

Where

$y_{\lambda}$  is the standard luminosity function,

$J_{\lambda}$  is the spectral power distribution of the radiant intensity.

The luminous coefficient is unity for a narrow band of wavelengths at 555 nanometres.

Note that  $\int_0^{\infty} y_{\lambda} J_{\lambda} d\lambda$  is an inner product between  $y_{\lambda}$  and  $J_{\lambda}$  and that  $\int_0^{\infty} J_{\lambda} d\lambda$  is the one-norm of  $J_{\lambda}$ .

**(8) Utilization factor:** this is also known as coefficient of utilization. It takes care of the utilized flux out of the total flux produced reaching the working plane, since the source of the emitted flux cannot get to the working plane. The effect of the above is to reduce the illumination

of a working plane or contrarily, increase the power of the light source to achieve a given level of illumination.

**(9) Maintenance factor:** this is a ratio of the average illumination on the working plane after a specific period of use of a lighting installation to the average illumination obtained under the same conditions for a new installation due to ageing of lamps and the effect of dust and dirt.

## **2.9 HISTORICAL PERSPECTIVE ON THE POINT METHOD**

As noted in the terminology section, the 'point method' is a procedure for predetermining the illuminance at various locations in lighting installations, by use of luminaire photometric data. This is the approach adopted here. In the late 1960's, computational power was just beginning to become available. The Illuminating Engineering Society wrote the following about the point method in 1969: "Calculation methods make it possible to pre-determine the foot candle (lux) distribution provided by any given aiming pattern. However, because such calculations are long and tedious, it is general practice to base spotting or aiming diagrams. On scale plots of the beam spread and the area to be lighted, previous calculations, and practical experience.

### **2.9.1 The point by point method**

The illuminance values for a uniformity check are calculated using the point-by-point method. The inverse square law and cosine law are used to calculate illuminance at a point from intensity data.

A floodlight of mounting height  $h$  lights up the point  $p$ , as shown in Fig. 2.11, the horizontal illuminance ( $E$ ) is given as follows:

$$E = \frac{I \cos\theta}{d^2} \dots\dots\dots (2.1)$$

Where I is the illuminous intensity in the direction of point p in fig. 2.12

Since

$$h = d \cos\theta \dots\dots\dots (2.2)$$

Therefore,

$$E = \frac{I \cos^3\theta}{h^2} \dots\dots\dots (2.3)$$

Taking maintenance factor (MF) and atmospheric loss (AL) into account, Eqn. (2.3) is rewritten as:

$$E = \frac{I \times AL \times MF \times \cos^3\theta}{h^2} \dots\dots\dots (2.4)$$

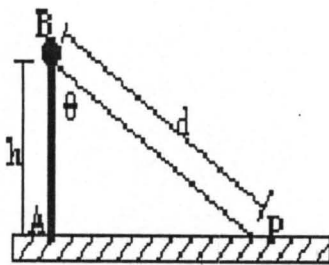

Fig 2.11 the Point-by-point Method

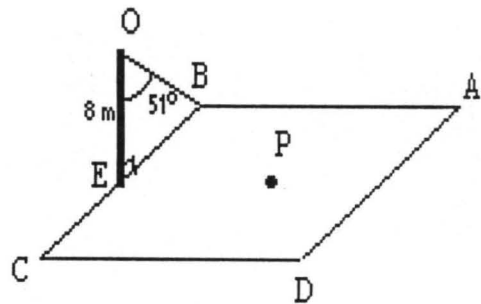

Fig. 2.12 Illuminance on Pont B



### 2.9.2 Calculation of illumination (lumen Method)

The illuminations engineering societies (IES) defines light as “visually evaluated radiant energy” or better still, a form of energy that permits us to see. The most frequently used method of calculating illumination is the lumen method.

### 2.9.3 Illumination formulae

The formula for obtaining the total number of lumens required for types of environment is as follows:

$$\text{Total lumens} = \frac{\text{Luminance} \times \text{Area of Working Plane}}{\text{MF} \times (\text{m}^2)} \dots\dots\dots (2.1)$$

From the above,

$$\text{Luminance E} = \frac{\text{Total Lumen (lm)} \times \text{MF} \times \text{CU}}{\text{Area (m}^2\text{)}} \dots\dots\dots (2.2)$$

Also the formula for obtaining the total number of lamps required for a given illumination level is as follows:

$$\text{Number of lamps, N} = \frac{\text{Total Lumens}}{\text{Luminous Flux}} = \frac{F}{\phi} \dots\dots\dots (2.3)$$

Where:

$$\text{Area} = \text{Area of Working Plane (m}^2\text{)}$$

MF = Maintenance Factor

CU = Coefficient of Utilization.

$\Phi$  = Luminous Flux per Lamp or Lumen/Lamp (lm).

# CHAPTER THREE

## DESIGN PROCEDURE

In this chapter, the step by step approaches used in the design of the 5km streetlight were discussed in detail. This includes stating in detail the lighting requirement, selecting the pole used, using the point by point method to calculate the total intensity of light, calculation of the total number of lamps required, calculation of load required the and a clear sketch of the power supply network diagram. The block diagram below shows clearly the different steps taken.

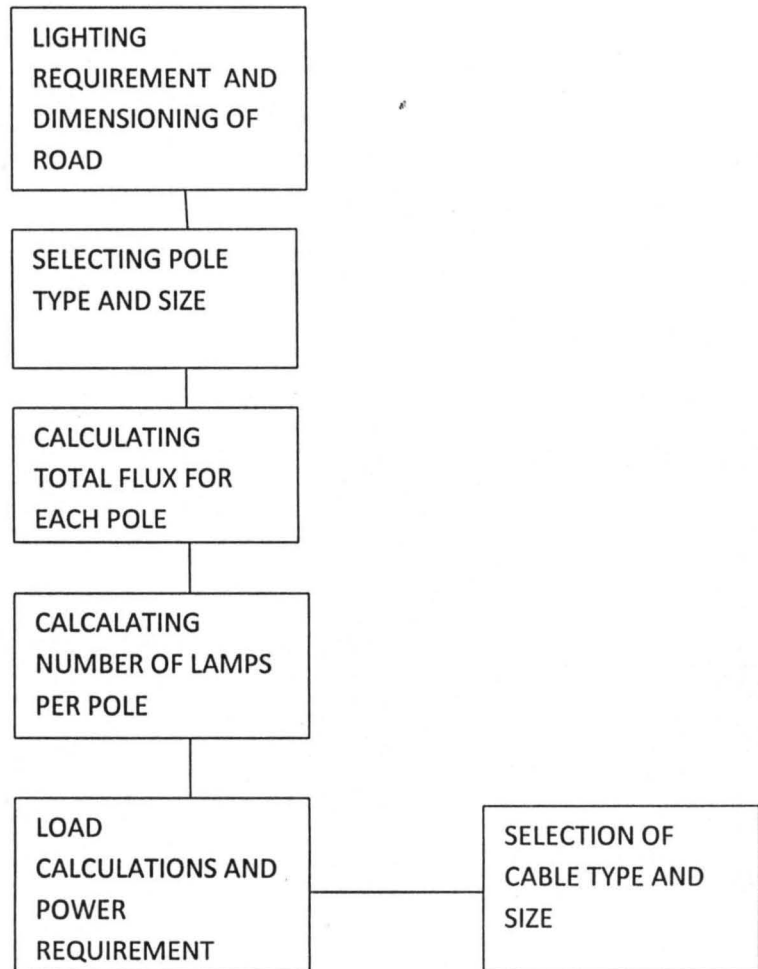

Figure 3.1 Block diagram to illustrate design procedure

### 3.1 LIGHTING REQUIREMENT

It is required that the road have a minimum illuminance of 15 lux at the centre of the road and a minimum of 8 lux at the road kerbs as shown in figure 3.2 below.

The length of road required is 5km.

The standard width of a single lane dual carriage road is 8m.

The height of pole used in this project is 7m. Figure below shows the type of pole to be used in this project.

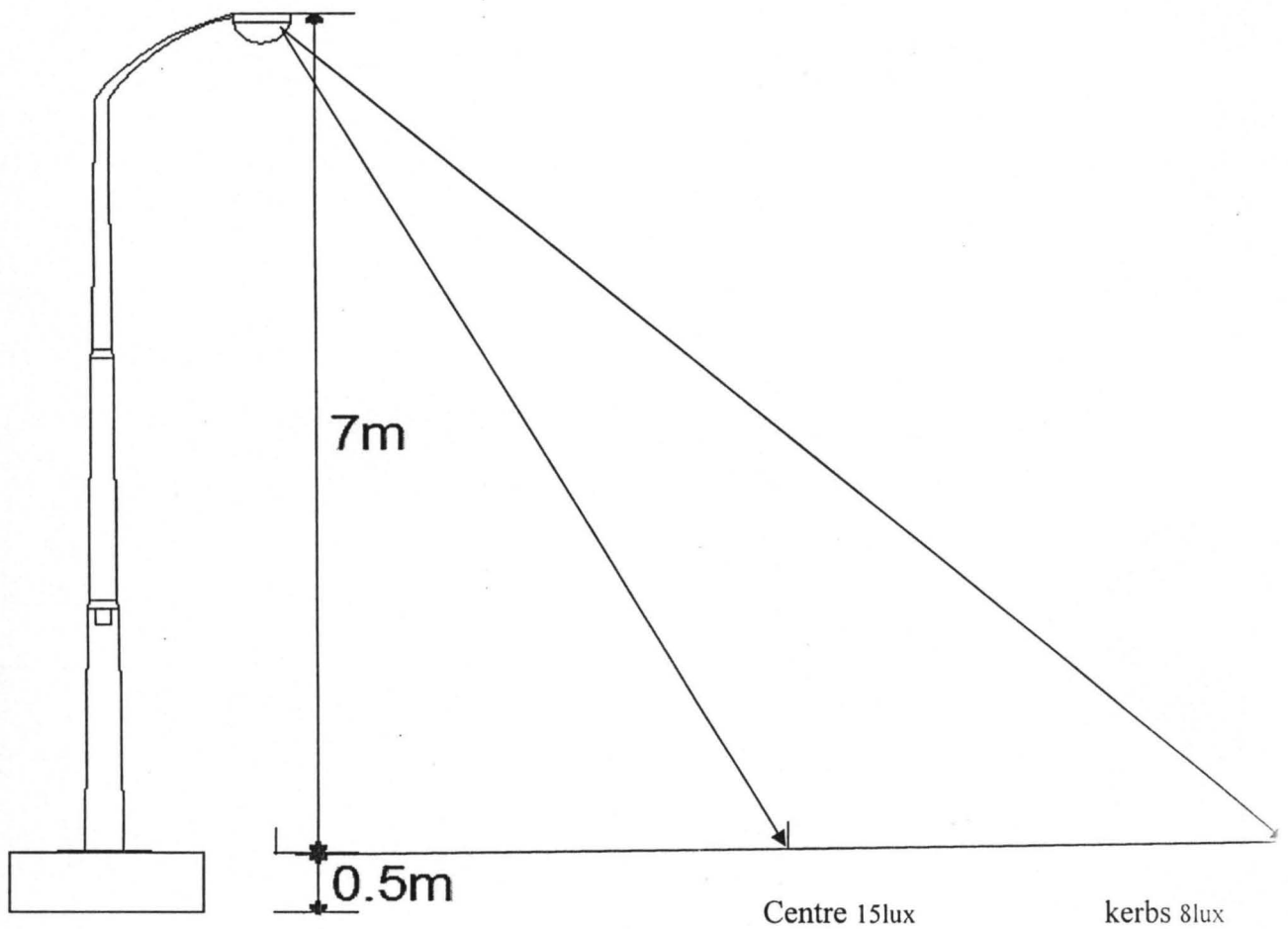

Figure 3.2 Street light pole illuminating a road

The relationship between the height of the pole, distance of point source from the foot of the pole, and the luminous intensity is described with the use of the diagram below

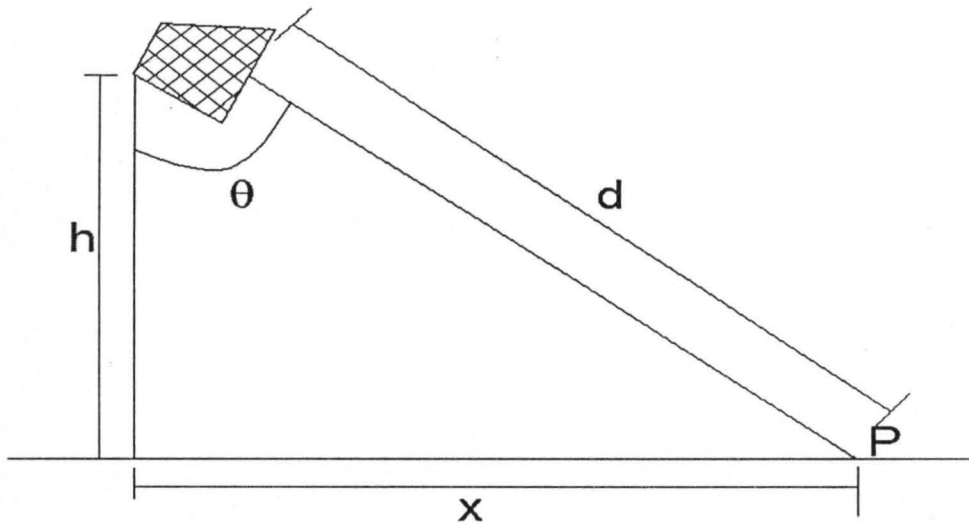

Figure 3.3 relationship between H, X and D

Where **h** is the height of the pole, **x** is the distance of the point under consideration to the foot of the lamp and **d** the distance of the lamp source to the point.

By Pythagoras theorem,  $d = \sqrt{x^2 + h^2}$  and

$\cos \theta = (h / d)$  from trigonometry. The figure below shows the type of pole to be use in this project

### 3.2 CALCULATION OF TOTAL LUMEN (FLUX) OF LIGHT REQUIRED FOR EACH POLE

The luminous intensity, **I** is given by,

$$I = \frac{E \times d^2}{\cos \theta}$$

$\cos \theta$

Where  $E$  is illuminance,  $d$  is distance of the lamp source to the point and  $\theta$  the lamp's angle of inclination.

For this project, The length of the road is 5000m (5km) and we know that the standard distance between two street light poles is 50m. Therefore the number of poles required  $= \frac{5000}{50} = 100$  poles Figure 3.2 below shows an outlay of the road.

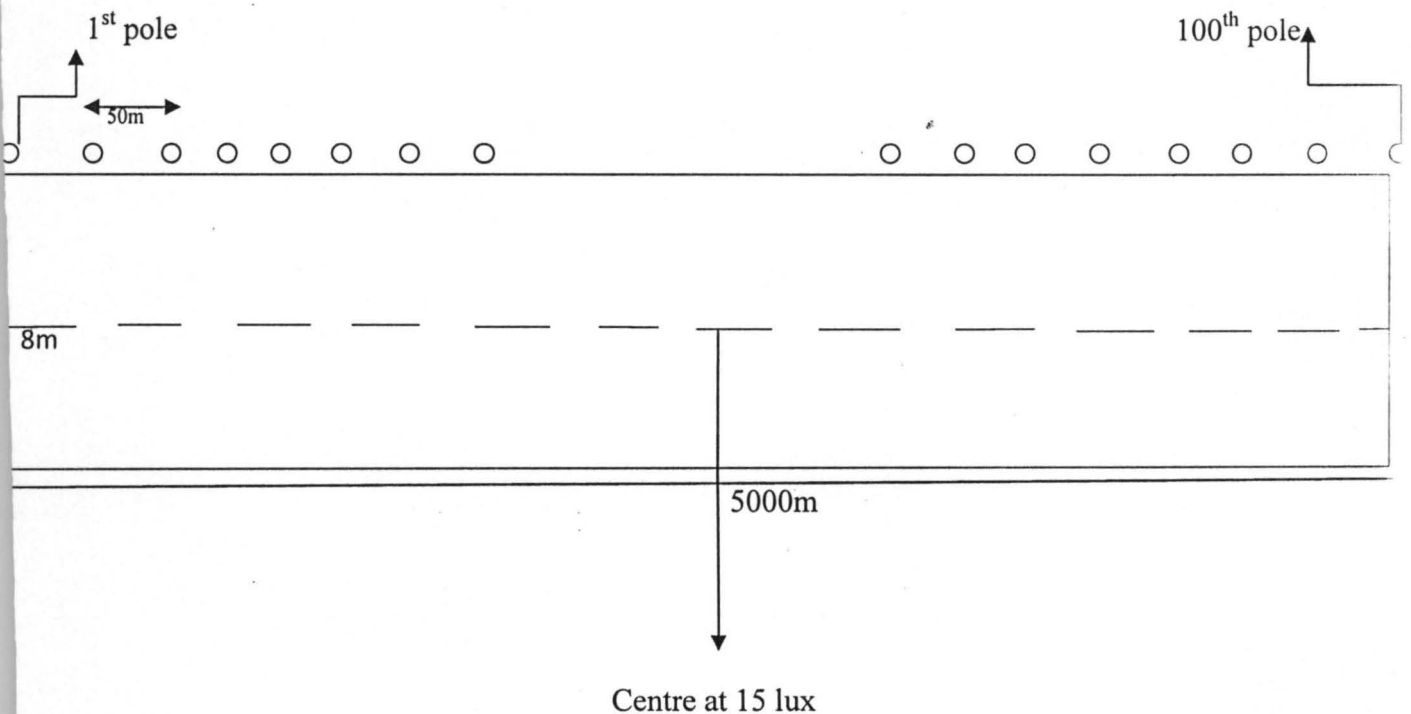
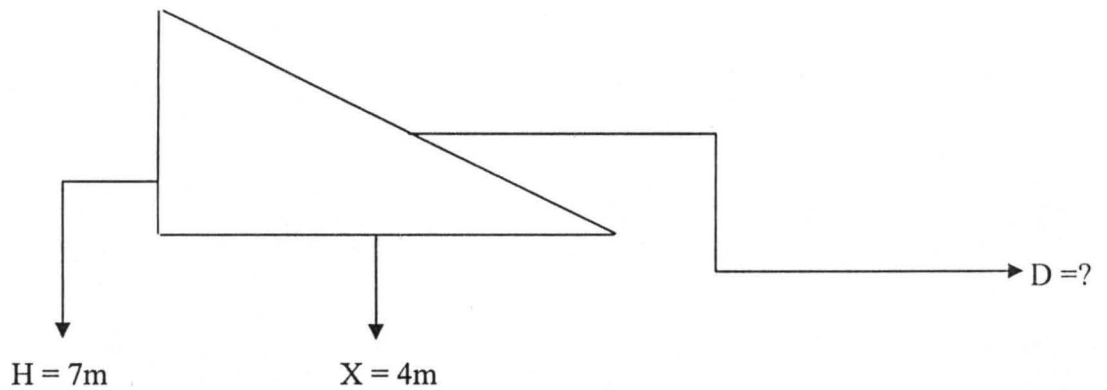

Figure 3.4 Dimensioning of road and positioning of poles

The road is 5km by 8m in size and it is required that the minimum illuminance at the centre of the road be 15 lux and 8 lux at the road kerbs. Both cases will be considered and the one with maximum number of lamps per pole will be utilised as it will supply the needed illuminance for the one with a lower illuminance. For a single pole, the total lumen required to give 15 lux minimum at the centre of the road is calculated as shown below.

For each pole at 15lux central;



Thus by Pythagoras theorem,

$$D^2 = X^2 + H^2$$

$$D^2 = 7^2 + 4^2$$

$$= 65$$

$$D = \sqrt{65} = 8.063\text{m}$$

$$\cos \theta = h/d$$

$$\cos \theta = 7/8.063$$

$$\cos \theta = 0.868$$

$$I = \frac{E \times d^2}{\cos \theta} = \frac{15 \times 65}{(0.868)}$$

$$I = 1123.27\text{cd.}$$

$$\text{Total flux } \phi_{\text{total}} = 4 \times \pi \times 1123.27$$

$$\text{Total flux } \phi_{\text{total}} = 14117.281\text{lumen}$$

The road kerbs are 8m from the foot of the pole as illustrated below

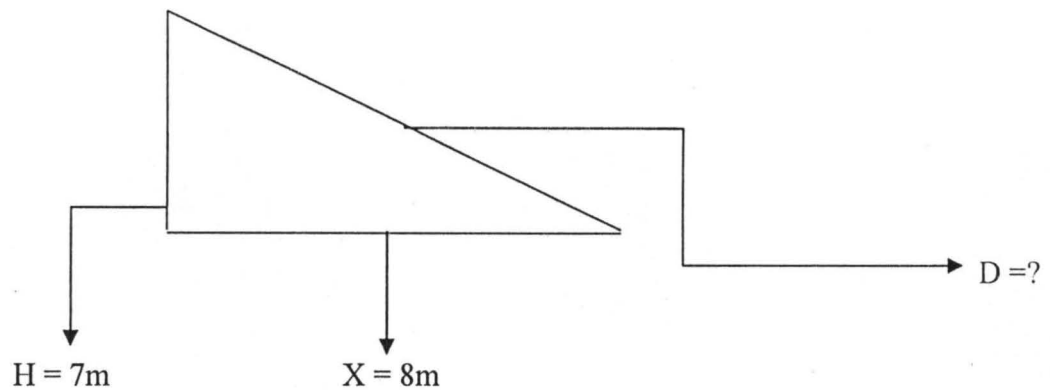

Similarly, by Pythagoras theorem,

$$D^2 = X^2 + H^2$$

$$D^2 = 7^2 + 8^2$$

$$= 113$$

$$D = \sqrt{113} = 10.63\text{m}$$

$$\cos \theta = h/d$$

$$\cos \theta = 7/10.63$$

$$\cos \theta = 0.6585$$

$$I = \frac{E \times d^2}{\cos \theta} = \frac{8 \times 113}{0.6585}$$

$$\cos \theta \quad (0.6585)$$

$$I = 1372.82\text{cd.}$$

$$\text{Total flux } \phi_{\text{total}} = 4 \times \pi \times 1372.83$$

$$\text{Total flux } \phi_{\text{total}} = 17253.56 \text{ lumen}$$

Therefore maximum flux needed is 17253.56 lumen and minimum flux is 14117.281 lumen

The same results will be obtained for all the pole as there dimensions are the same.



### 3.3 CALCULATION OF TOTAL NUMBER OF LAMPS FOR EACH POLE

$$\text{Number of lamps per pole} = \frac{\text{Total Lumen}}{\text{Lumen per lamp}}$$

A 250W BT28 mercury vapour lamp will be used in this project bearing in mind that the higher the lamp power, the lesser the number of lamps required.

Average efficiency of a mercury vapour lamp = 50 lumen/watt

Total lumen per lamp =  $250 \times 50 = 12500$  lumen/lamp

For each pole

Minimum number of lamps required for each pole considering 15lux at the centre of the road

$$\text{Number of lamps (N)} = \frac{14117.281}{12500} = 1.129 \sim 2 \text{ lamps}$$

Maximum number of lamps required for each pole considering 8lux at the road kerbs

$$\text{Number of lamps (N)} = \frac{17253.56}{12500} = 1.38 \sim 2 \text{ lamps}$$

A number of two lamps can illuminate both flux conveniently. Number of lamps per pole is two

Hence total number of lamps =  $2 \times 100 = 200$  lamps

### 3.4 LOAD CALCULATION AND POWER REQUIREMENT

#### 3.4.1 Power consumed per phase and fuse rating

Capacity of the lamp = 250W

Total number of lamps used = 200 lamps

Total power requirement for 200 lamps =  $250 \times 200 = 50000\text{W}$  or 50KW.

For the purpose of attaining equal load sharing among the three phase supply, the total number of lamps is shared almost equally among all three phases. As 200 cannot be divided with 3 without

remainder, the Red phase is allowed to power 68 lamps and the other two phases 66 lamps each.

Thus the current drawn by each phase is given by;

RED PHASE; Total power of 68 lamps =  $68 \times 250 = 17000\text{W}$

Hence current drawn by red phase

$$I = \frac{P}{V \cos \theta} = \frac{17,000}{230 \times 0.8} = 92.39\text{A}$$

YELLOW PHASE; Total power of 66 lamps =  $66 \times 250\text{W} = 16,500\text{W}$

Hence current drawn by blue phase

$$I = \frac{P}{V \cos \theta} = \frac{16,500}{230 \times 0.8} = 89.67\text{A}$$

BLUE PHASE; will draw the same current as the YELLOW phase as they power equal number of lamps.

The current drawn by each phase is within the range of 92.39A to 89.67A and we know that the fuse rating must be able to carry three times the current, therefore a 300A rated capacity fuse will be used.

### 3.4.2 Calculation of total line current

For three phase supply, power (P) is given by

$$P = \sqrt{3}VI \cos \theta$$

$$\text{Thus } I = \frac{P}{\sqrt{3}V} = \frac{50,000}{\sqrt{3} \times 230} = \frac{50,000}{1.732 \times 230 \times 0.8} = 156.88\text{A}$$

### 3.4.3 Distribution board layout

The load on each phase was conveniently fused to avoid short circuit damage. For the red phase, a 12 way single phase and neutral (SP&N) distribution board was utilised where eleven of

the twelve single phase and neutral were taped to supply 3 poles each and the twelfth one supplying just a pole. The current drawn by any final sub-circuit is given by;

$$I = \frac{250 \times 2}{230 \times 0.8} = 2.72A$$

Thus we can conveniently use a 5A fuse rating for the final sub-circuit feeding each street light pole. The same applies to other two phase (yellow and blue) as each final sub-circuit is carrying 2 lamps. The arrangement of each final sub-circuit is shown in the Fig 3.5 below

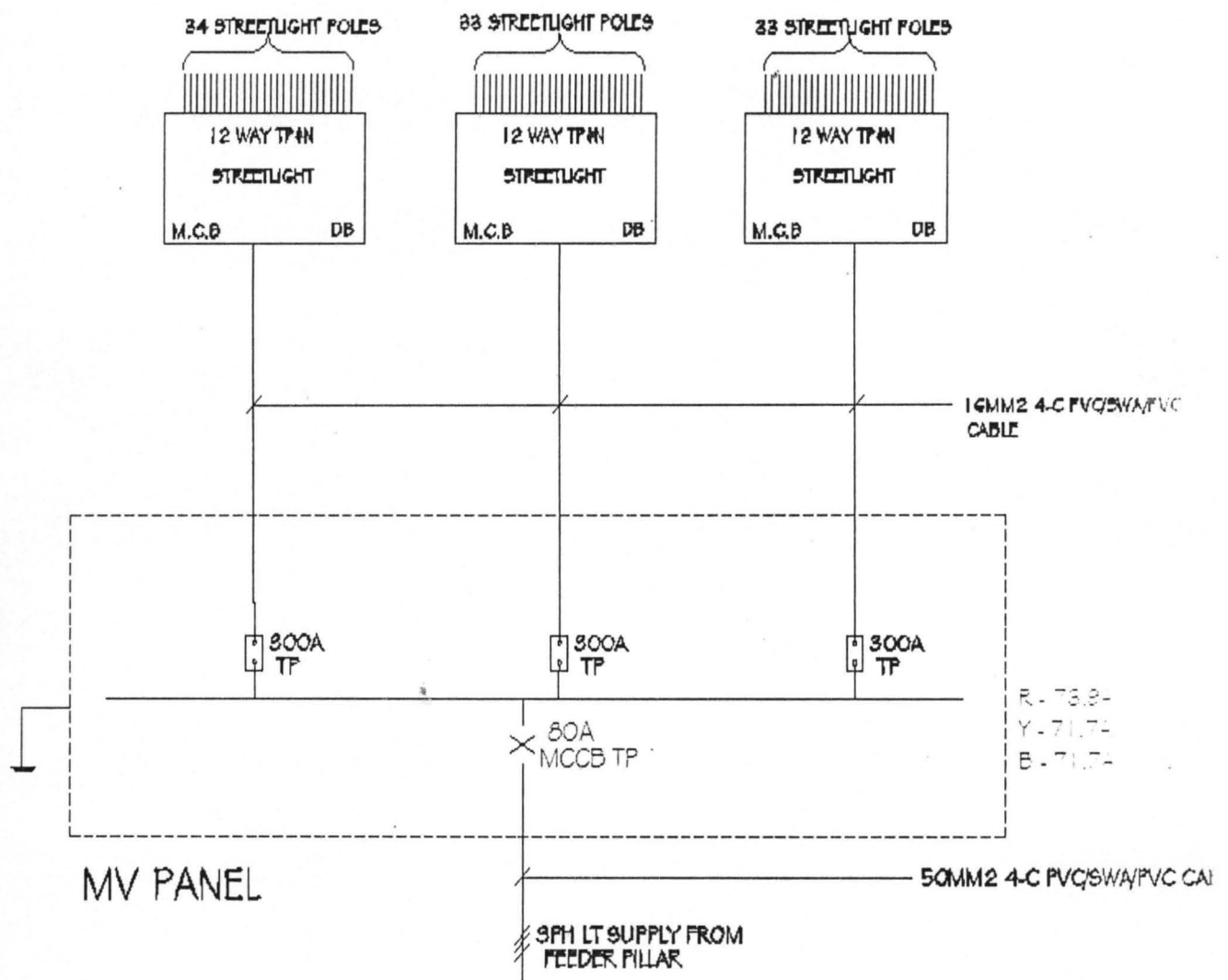

Figure 3.5 power network diagram



### **3.5 CABLING**

The type of cables to be used for a particular installation application is based on current carrying capacities of the various cables, specified by the IEEE regulation and also on general field practice.

From the load calculation, the total total line current for the entire street light is approximately 125.5A therefore a 50mm<sup>2</sup> 4 core PVC/SWA PVC Cable will be used as the incomer (Main cable) to the streetlight.

Sub main cable is a 16mm<sup>2</sup> 4 core PVC/SWA PVC Cable to satisfactorily withstand the current

Final sub circuit is a 1mm<sup>2</sup> PVC/SWA PVC Cable to satisfactorily withstand 2.7A

### **3.6 CHOICE OF TRANSFORMER**

The total power consumed by all 200 lamps is 50KW and thus an 80KVA, 11KV/415V transformer will be used to conveniently carry the load and provide for future extension of streetlight

### 3.7 POWER SUPPLY NETWORK DIAGRAM

The power supply network diagram shows in detail the transformation of power from the generating station to the final sub-circuit supplying the load. The station generates power at a voltage of 6-20KV which is then stepped up to 330KV so as to reduce the voltage loss along the transmission line, the size of cables and the switch gears used. After transmission the voltage is reduced to 132KV at transmission sub-station to aid distribution. A step down transformer is used to step it down to 33/11KV. At this level, major industrial consumers tap the supply to their load transformers. In this project an 80KVA transformer was used to step the 33/11KV to 230V

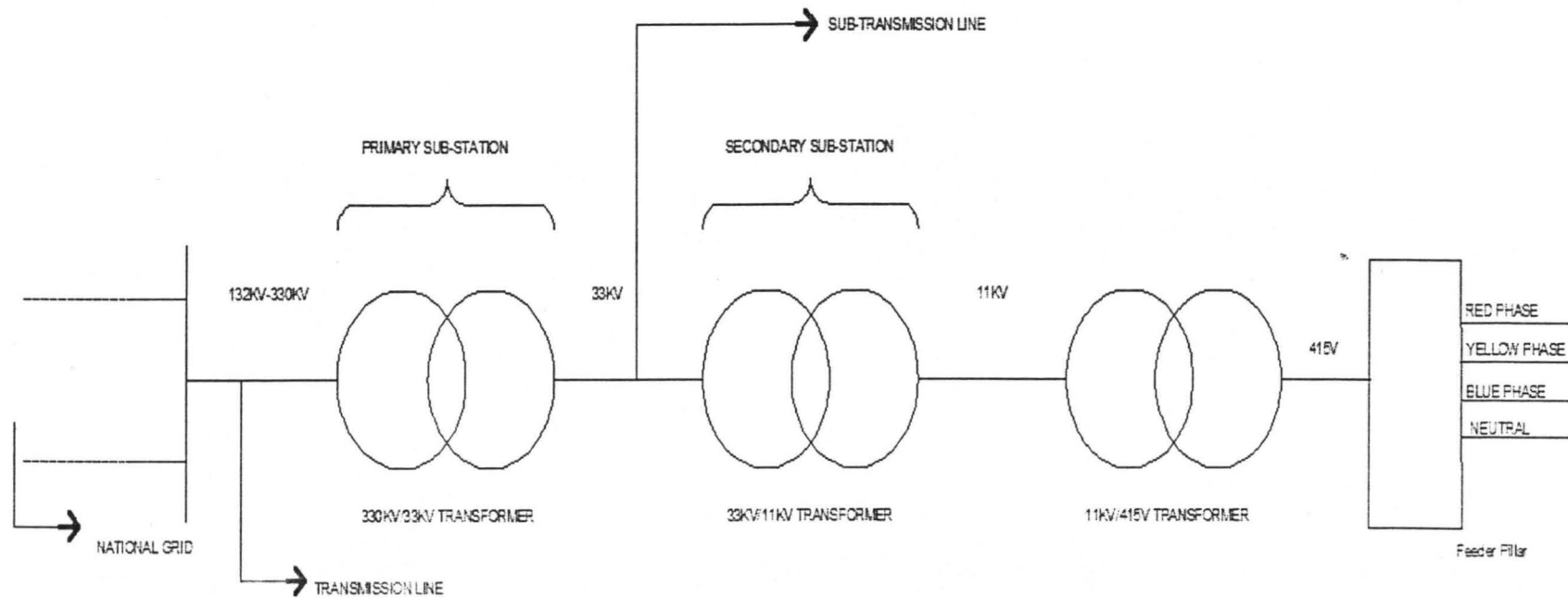

Figure 3.7 power supply network diagram

### 3.8 RECOMMENDED DESIGN CRITERIA

TABLE 3.1: Table of Recommended design criteria

DESIGN CRITERIA	
TYPE	MAST ARM
LAMP	MERCURY VAPOUR LAMP
WATTAGE	250WATT
POLE HEIGHT	7m
COLOUR	NON PAINTED GALVANISED
SPACING	50m
DESIGN GUIDLINE	15 LUX AT THE CENTRE OF THE ROAD AND 8 LUX AT THE ROAD KERBS

## CHAPTER FOUR

### DESIGN IMPLEMENTATION & COSTING

In this chapter, the cost of each material to be used in implementing the project stated and the total cost of implementation was calculated as a way of providing construction engineers the cost effectiveness and efficiency of the project. The cost of each material is calculated below;

#### 4.1 LIGHTING

Any lamp could have been specified for this project work for reasons of longer lamp life (reliability), durability and brightness the mercury vapour lamp have been specified. They have a far greater lighting effect than other lamps with the same wattage.

TABLE 4.1: Cost table for mercury vapour lamp

S/N	DESCRIPTION	RATING (WATT)	QUANTITY	UNIT COST(₦)	TOTAL COST(₦)
1	BT28 MERCURY VAPOUR LAMP	250	200	1785	357,000
	TOTAL				357,000



## 4.2 STREET LIGHT POLES

The range of heights to give maximum illuminance and diversity of incident flux is Between 3m to 12m for street lights. A 7m height pole will be used in this project.

**TABLE 4.2: Cost table for streetlight poles**

S/N	TYPE	POLE HEIGHT(m)	QUANTITY	UNIT COST(₦)	TOTAL COST(₦)
1	MAST ARM	7	100	90,000	9,000 000.00
	TOTAL				9,000 000.00

## 4.3: Cost table for power and lighting

S/N	DESCRIPTION	QUANTITY	UNIT COST(₦)	TOTAL COST(₦)
1	35mm <sup>2</sup> 4 core PVC/SWA PVC Cable	50m	1,050	52,500.00
2	16mm <sup>2</sup> 4 core PVC/SWA PVC	6Km	594	3,564,000.00
3	1mm <sup>2</sup> PVC/SWA PVC Cable	900m	130	117,000.00
4	12-WAYS S&PN	3	42,000	75,000.00

	DB			
5	80 KVA, 11KV/415 V TRANSFORMER	1	250,000	250,000.00
6	2 WAY STREET LIGHT LAMP HOLDER	100	12,000	12,000 000.00
	TOTAL			19,622,500.00

**4.3 TOTAL COST OF PROJECT; ₦35, 681, 000.00**

## CHAPTER FIVE

### 5.1 SIGNIFICANCE

The aim of this project is to design street light arrangement for a road of 5 km using mercury vapour lamp with a minimum illuminance of 15lux at the centre of the road and minimum of 8lux at the road kerbs, and also the power supply network.

Significance of this includes:

1. Reducing accident rates as some vehicles lack source of illumination at night.
2. Reducing crime and vandalism. Criminals are more comfortable in committing crimes when they feel invisible
3. Making residents feel secure. Pedestrians and residents of streets cannot feel safe when their streets are completely dark.
4. Meeting up of demand and effectiveness
5. Protection of life and properties (equipment)
6. Catering for some basic needs to meet up with the prevailing lifestyle in the light of technological advancement

### 5.2 LIMITATION

Since this project is hypothetical, even though feasible, the major limitation it has is that it is not being implemented. Also as a result of its hypothetical nature, the cost of design was not taken into consideration in arriving at the total project cost.

Another limitation is that due to fluctuations on the market prices, design and implementation cost may vary.

### 5.3 CONCLUSION AND RECOMENDATION

From the results obtained, the following conclusion can be drawn.

- i. The project can easily be realized by using very little resources i.e., it is cost effective.
- ii. The importance of lighting to our society can be met without facing any complexity i.e., the project design technique is simple.
- iii. The project can easily be modified to suite any size of road as each parameters involved have been clearly defined.
- iv. The project if implemented will increase employment rate as there are several areas of study involved.

It is recommended that cabling method used in the project be underground as it is safer, more reliable & more durable

It is also recommended that the implemented project always be maintained i.e., there should be constant replacement of damaged lamps, constant cable inspection, re-erection of fallen poles, etc.

Lastly, the power supply to the street lights should be steady in order to increase transformer life-span.

## REFERENCES

1. Oria Usifo, "ELECTTRICAL NETWORKS, DESIGN AND INSTALLATION IN BUILDINGS", 2<sup>nd</sup> edition, FREDORUS Ltd, Benin City, 1998. , pp 41-125 .
2. Oria Usifo, "RESEARCH PROJECT IMPLEMENTATION MADE EASY AND ELECTRONIC ENGINEERING", FIRST EDITION, ECAS (NIG)., LAGOS, 2004, PP53-64 vol 1, 2004.
3. J.O Paddock, ELECTRICAL INSTALLATION TECHNOLOGY AND PRACTICES, 8<sup>th</sup> Edition, 1997.
4. The New Encyclopedia Britannica Micropedia Ready Reference, Vol 4, 15<sup>th</sup> Edition.1998
5. IEEE "Regulations for the Electrical Equipment of buildings", 15<sup>th</sup> Edition IEE Savoy place London, 1981. 16<sup>th</sup> Edition.
6. Mercury Vapour Lamp Manual
7. Lecture Note; (ECE 514) Prof. Oria Usifo, 2010
8. Wikipedia, "Halogen\_lamp", <http://en.wikipedia.org/wiki/>
9. Wikipedia, "Mercury-vapor\_lam"p, <http://en.wikipedia.org/wiki/>
10. Wikipedia," Luminance ",<http://en.wikipedia.org/wiki/Luminance>
11. Wikepedia,"LIGHTING", <http://en.wikipedia.org/wiki/Lighting>
12. Wikipedia, "Fluorescent\_lamp", <http://en.wikipedia.org/wiki/>.
13. Wikipedia, "Illuminance", <http://en.wikipedia.org/wiki/>
14. Wikipedia, "Luminous\_energy"<http://en.wikipedia.org/wiki/>.
15. Wikipedia, "Luminous\_flux" <http://en.wikipedia.org/wiki/>
16. Wikipedia, " Luminous\_intensity " <http://en.wikipedia.org/wiki/>.
17. Wikipedia, 'Luminous\_emittance"<http://en.wikipedia.org/wiki/>