

**DESIGN AND CONSTRUCTION OF A  
PARABOLIC  
ANTENNA.**

**BY**

**IBRAHIM JIMADA**

**97/6022EE**

**A PROJECT REPORT SUBMITTED IN  
PARTIAL FULFILMENT OF THE  
REQUIREMENT FOR THE AWORD OF  
BACHALOR OF ENGINEERING (B. ENG)  
DEGREE TO THE DEPARTMENT OF  
ELECTRICAL AND COMPUTER  
ENGINEERING  
FEDERAL UNIVERSITY OF  
TECHNOLOGY, MINNA NIGER STATE**

**SEPT 2003**

**APPROVAL PAGE**

This is to certify that this project was carried by me under the supervision and guidance of Eng. Dr Y.A Adediran in the department of Electrical and computer Engineering Federal University of Technology, Minna.

.....

Dr . Y.A Adediran.

Supervisor.

Date:.....

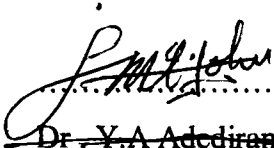
  
.....  
~~Dr . Y.A Adediran.~~

H.O.D

Date: 7/4/09 .....

.....

External Supervisor

Date:.....

## **CERTIFICATION**

I here by certisfy that this project work was carried out by me under the supervision of Dr Y.A Adediran of the department of electrical and Computer Engineering Federal University of Technology, Minna.

**DECLARATION**

I here by declare that this is my original work and has never been presented else where for the award of any degree

**Ibrahim Jimada**

.....

**Student Name**

Sign.  .....

## **DEDICATION**

This project is dedicated to my parent Alh Ibrahim Jimada and Malama Hauwa-Kulu Ibrahim for their amazing foresight, industry, endurance and more importantly for their yielding faith in education and to the memory of my step mother *MALAMA HABIBA* Ibrahim and my grandfather Alh U.A *ABUBAKAR UBANDAWAKI OF BUDDON* May their soul rest in perfect peace. (Amen).

## ACKNOWLEDGEMENT

First and foremost I Thank the Almighty Allah for his love, mercy and grace bestowed on me and strength he endowed me with for the successful completion of this project. This would be In complete without acknowledging the various contributions and assistance of people directly or indirectly towards the Fulfillment of the objective of this project work and ultimately in the realization of my academic goals.

To this effect I give great thanks to my supervisor Eng. Dr Y. A Adediran who is also the H.O.D of my department for the role he played despite his tight schedule, and all the academic and non academic staff of the department of electrical and computer engineering of federal university of technology minna.

My thanks and appreciation goes to my parent Alh. Ibrahim Jimada, my mother malama kulu Ibrahim, my late step mother Habiba (kaka), Ya-zara to Instilled in me the will to succeed, They Provide the foundation and the support for my academic achievement". I owe every thing to them. My appreciation goes to all my brothers and sisters especially lami, talatu, danlami, Jumai, tanimu, dakaki, and kaka kyeukyeu, for their support, word of encouragement and prayers. I equally acknowledge the tireless efforts of my late grandfather Alh U.A. Abubakar and his family, the family of late J.G, late mallam Jinada Moh'd and his family, my grand mother (ya-kaka), Anti Gambo, uncle Gimba and Anti Ladi.

My appreciation to all my school friends especially moh'd rabiou Lawal, suleiman Hameed, Adamu Isah daga, moh,d maigida, Abdulrazaq D musa,Isah Aliyu, suleiman zubair and .co.

I will not forget to mention some esteem Individuals whose effort are immeasurable like Ndagi Abu, yakaka - adi, Bafa, Baba ALiyyu, Dr Mrs Moh'd, yamu, Idrisu, danlami (moh'd Jimada), Eng. I. B musa, Ndagi Nma dentist, Ndagi Ahmadu, sule J.G ya Idrisu, Abaji yakan-nma minna, ya tine tanimu, Anti salamatu, Late gogo kisu, ya gbari, Amarya, Yakan Ndagi Abu, Nnagi Lara, Anti tani, Tapha, datsu, momobilet, and Co. My sisters, ya-sabe, Ladidi, Nanyawa, Rukaiya. danjuma (yamakanta). ya danako, mallam musa Hayatu moh'd Abdulkadr (dayatsu), Bros B&C, Galasa, Abu, and rest who

are too numerous to mention I love you all. and the staff of city computer centre who took Pain to print this project.

Alhamdulillah.

## **ABSTRACT**

This project is based on receiving signal, which antenna and its component are inevitable instruments that receive the wave-transmitted signal. However, this is basically on the process involved in the design, construction and testing of a parabolic antenna. For receiving signal, from any nearer by T.V Station.

An iron sheet was used to construct a parabolic disk of about 0.60m in diameter with a focal point of 0.20m. On passing an aluminum rod through the focal point, the electromagnetic wave (rays) which incidented on the surface of the parabola converged at the focus after reflection was collected by this dipole. When this apparatus was connected to the television, a brighter reception was obtained for NTA Minna

depending on the direction of the antenna surface. This implies that the parabolic antenna also aids in communication transmission by receiving Electromagnetic waves in the form of unguided mode, and transform such signal into the required form



## TABLE OF CONTENT

APPROVAL PAGE.....	i
CERTIFICATION.....	ii
DECLARATION.....	iii
DEDICATION.....	iv
ACKNOWLEDGEMENT.....	v
ABSTRACT.....	vii
<b>CHAPTER ONE</b>	
INTRODUCTION.....	1
LITERATURE REVIEW.....	2
<b>CHAPTER TWO</b>	
TYPES OF ANTENNA.....	3
ARRAY ANTENNA.....	3
WIRE ANTENNA.....	4
APERTURE ANTENNAS.....	5
REFLECTOR ANTENNAS.....	6
LENS ANTENNAS.....	7
<b>CHAPTER THREE</b>	
FOUNDAMENTAL PARAMMETERS OF ANTENNAS.....	10
INTRODUCTION.....	10
RADIATION PATTERN.....	10
ISOTROPIC, DIRECTIONAL AND OMNI DIRECTIONAL PATTERN.....	11
RADIATION POWER.....	12
RADIATION INTENSITY.....	13
DIRECTIVITY.....	13
GAIN.....	14
ANTENNA EFFICIENCY.....	15
BAND WIDTH.....	16
POLARIZATION.....	17
INPUT INPEDANCE.....	17
<b>CHAPTER FOUR</b>	
DESIGN AND CONSTRUCTION OF A PARABOLIC ANENNA OR REFLEC- TOR.....	19
INTRODUCTION.....	19
DESIGN SPECIFICATION.....	19
REQUIMENT.....	21
CASING.....	22
TESTING AND RESULT.....	22
<b>CHAPTER FIVE</b>	
DISCUSSION.....	24
CONCLUSSION.....	26
RECOMMENDATION.....	27
REFERENCES.....	28

## CHAPTER ONE

### ANTENNAS

#### 1.1 INTRODUCTION

Radio antenna have two main function. The first of this is to receive or radiate the radio frequency energy generated in the transmission line.

In this capacity the antenna acts as an impedance matching device to match the impedance of the free space to that of the radio receiver. The other function of the antenna is to direct the energy into desired direction, and to suppress the radiation in unwanted direction (i.e. to prevent the unwanted radiation or frequency energy from getting to the free-space). Since the radiation or the transmission of the frequency is on the free space and the wavelength of the signal is small, both the transmitting and the receiving aerial can be mounted at the height of few of several wavelengths above the ground. An antenna is usually a metallic device for radiating or receiving radio waves.

THE I EEE' standard definition of terms for antennas [I EEE std 145 – 1973] defines the antenna or aerial as “a means for radiating or receiving radio waves”. In other words the antenna is the transitional structure between free – space and a guiding structure device. The guiding device or transmission line may take the form of a co-axial line or hollow pipe (wave-guide). And it is used to transport Electro magnetic energy [i.e. Inform of flux] from the transmission source to the antenna or from the antenna to the receiver.

In the former case we have a transmitting antenna and in the later a receiving antenna.

The characteristics of antenna is shown in detail analysis of some various types or categories of antenna in existence which will later be discussed in chapter two, while chapter three specifically described the general parameters of antenna that are responsible for their performances.

The last part of the write-up [i.e. chapter four] will treat or focus the actual design and construction of the parabolic reflector. While the Concluding part that is chapter five will have the conclusive part of the object work and will Confirm whether the aim and the objective is achieved.

## **1.2 LITERATURE REVIEW**

The first antenna was devised by a German physicist, Henrich Hertz, who about 1887 carried out a land mark experiment to test the theory of the British mathematician / Physicist James Clerk Maxwell that used light of along class of electromagnetic effect that could pass through air or empty space is a Succession of wave. Since communication is of great importance and various means of receiving signal from transmitting end has to be developed. Many types of antenna seems to be in existence for various purposes, but my major Concern is on parabolic antenna. The Construction of this type of antenna is of the form of dome shape or structure bounded by parallel Conducting surfaces termed as cheese or pill-box antenna. Linear antenna is placed on a line passing through the focus (focal point of the parabola) which are illuminated on the parabolic reflector antenna.

This will make the cylindrical wave front. Converted into plane wave after reflection from the parabola.

A square metal iron sheet is carved into parabolic shape and flat bars are welded to the iron sheet to support it while aluminum rod is penetrated through the focus point to transform the in coming signal into the plane wave, an co axial cable is connected to link the wave from the reflector to the T V set to enhance the perfection of the signal coming to the T V set which was achieved.

## CHAPTER TWO

### 2.1 TYPES OF ANTENNAS

Brief analysis on some forms of various types of antennas is discussed in this chapter.

### 2.2 ARRAY ANTENNAS

Many applications require radiation characteristics that may not be achievable by a single element. It may however be possible that an aggregate of radiating elements in an electrical and geometrical arrangement (an array) will result in the desired radiation characteristic.

The arrangement of the array may be such that the radiation from the elements adds up to give a radiation maximum in a particular direction or directions. Minimum in others, or otherwise as desired.

The typical examples of arrays are shown in the figure 2.2 below.



(a) Yagi – uda array

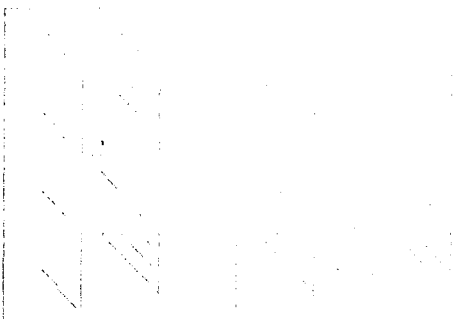

(b) Aperture array

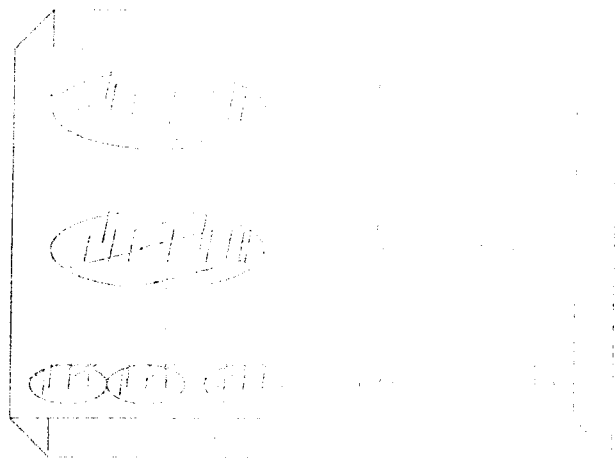

© Slotted wave guide array

Figure 2.2 Showing the typical wire and Aperture array Configuration

Usually the term array is reserved for an arrangement in which the individual radiators are separate as shown in figure 2.2 a and b above. However, the same term is used to describe an assembly of radiators mounted on a continuous structure as shown in figure 2.2 c above.

### 2.3 WIRE ANTENNAS

There are various shapes of wire antennas such as straight wire (dipole) loop, and helix which are shown in figure 2.3 below. Loop antennas need not only to be circular, but they may take the shape of a rectangle, Square, ellipse or any other configuration.

Wire antennas are familiar to the layman because they are seen virtually every where on automobiles, buildings, ships, aircraft, spacecraft and so on. The circular loop antenna is the most common form of loop antenna because of it simplicity in construction.

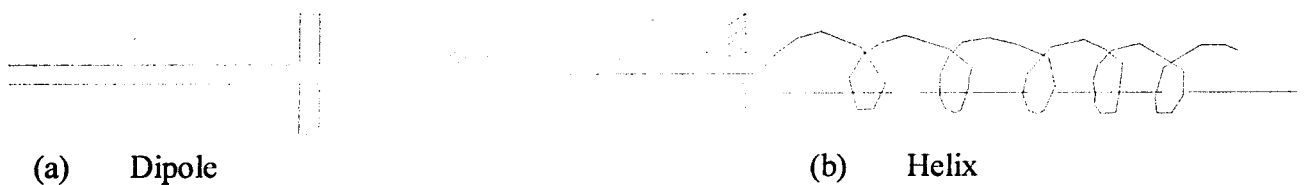

Fig 2.3 showing wire antenna configuration.

## 2,4 APERTURE ANTENNAS

Antennas of this kind are very useful for spacecraft or aircraft applications, because they can be conveniently flush – mounted on the surface of the aircraft or spacecraft. In addition, they can be covered with a dielectric material to protect them from environmental hazardous conditions.

The aperture antennas may be more familiar to the people or lay man to day than sophisticated forms of antennas and the utilization of higher frequencies. Some of aperture antennas are shown in figure 2.4

(a) Pyramidal horn

(b) Conical horn

© Rectangular wave guide

Fig 2.4 aperture antenna configuration.

## 2.5 REFLECTOR ANTENNAS

The success in the exploration of outer space has resulted in the advancement of antenna theory.

Because of the need to communicate over great distances, Sophisticated forms of antennas have to be used in order to transmit and receive signals that have to travel millions of miles. A very common antenna form for such application is a parabolic reflector shown in figure 2.5 a and b.

Antenna of this type have been built with diameter as large as 305m, such large dimensions are needed to achieve the high gain required to transmit or receive signals after million of kilometers of travel.

Another form of a reflector, although not as common as the parabolic is the corner reflector. Shown in figure 2.5 ©

The detail of parabolic antenna design and construction is the concern of the write up and as such it is treated in chapter four of this work.

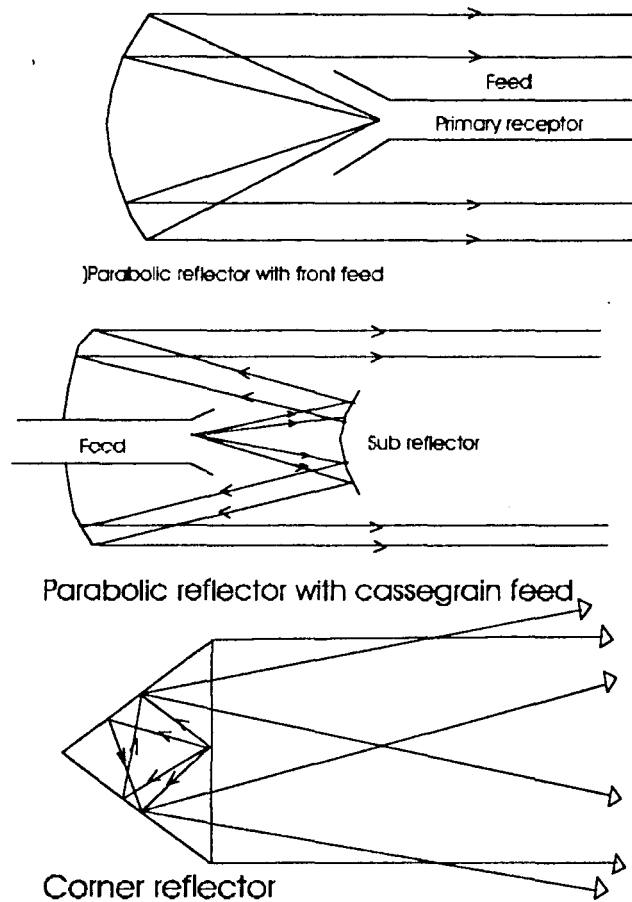

Fig 2.5 typical reflector configuration

## 2.6 LENS ANTENNAS

Lenses are primarily used to collimate incident divergent energy to prevent it from spreading in undesired direction. By the property shaping the geometrical configuration and choosing the appropriate material of the



lenses. They can transform various forms of divergent energy into plane waves.

They can be used in most of same applications as the parabolic reflectors. Especially at higher frequency. Their dimensions and weight become exceedingly large at lower frequencies. Lens antennas are classified according to the material from which they are constructed, or according to their geometrical shape.

Some forms are shown in figure 2.6 below.

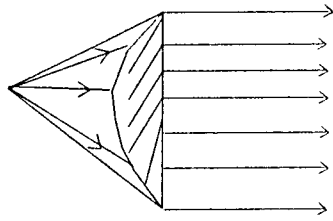

Convex - Plane

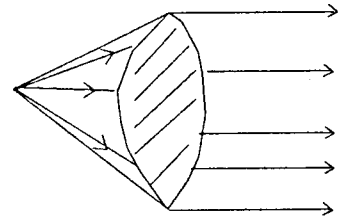

Convex - Convex

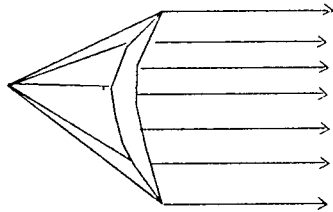

Convex - Concave

(A) Lens antennas with index of refraction  $n > 1$

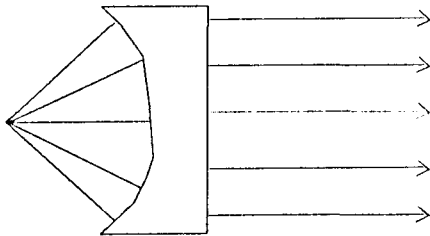

Concave - Plane

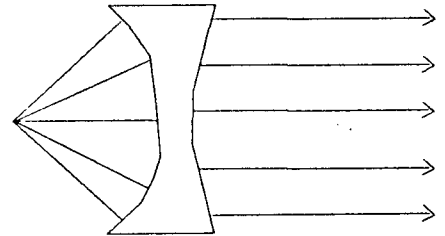

Concave - Concave

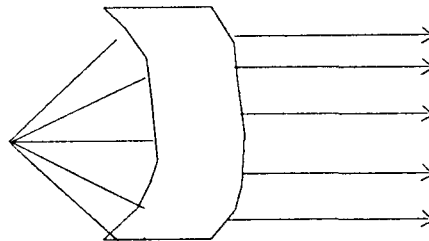

Concave - Convex.

(B) Lens antennas with refraction index  $n < 1$

**Fig. 2.6**  
Showing the typical  
Lens antenna  
Configuration.

## **CHAPTER THREE**

### **3.10 FUNDAMENTAL PARAMETERS OF ANTENNAS.**

#### **3.11 INTRODUCTION.**

To describe the Performance of an antenna, definitions of various Parameters are necessary. Some of the parameters are interrelated and not all of them need to be specified for complete description of the antenna Performances, Parameter definitions will be given in this chapter, those in Quotations will be from the IEEE Standard definitions of terms of antennas (IEEE std 145-1973)

#### **3.2.2 RADIATION PATTERN**

An antenna radiation pattern is defined as “a graphical representation of radiation Properties of the antenna as a function of Space Coordinates. In Most Cases, the radiation Pattern is determined in the far-field Region and is represented as a function of the directional Coordinates. Radiation Properties include radiation intensity, field Strength, Phase or Polarization's. The Co-ordinate System generally used in the Specification of antenna radiation Pattern is the Spherical Co-ordinate System ( $r, \phi, \theta$ .)

Shown in figure 3.1.the antenna is located at or near the origin of this System, and the field Strength is Specified at Point on the Spherical Surface or radius  $r$ . the Shape of the radiation Pattern is independent of  $r$ , as long as  $r$  is chose Sufficiently large (  $r$  must be very much greater than the Wave length and also Very much greater than the largest dimension of the antenna System ). When this is true the magnitude of field strength in any direction varies inversely with  $r$  and so needs to be stated for only on Value of  $r$ .

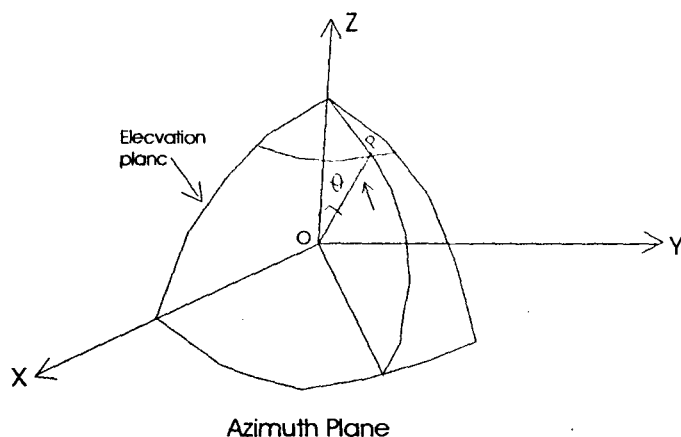

Figure 3.1 Spherical Co-ordinate System

### 3.2.3 ISOTROPIC, DIRECTIONAL AND OMNIDIRECTIONAL PATTERNS.

An Isotropic radiation is defined as “a hypothetical antenna having equal radiation in all direction’s An Point Source will be an example of such a radiator, Directional antenna is one “having the property of radiating or receiving electromagnetic waves more effectively in some directions than the others”.

Omnidirectional antenna is defined as one “having an essentially nondirectional Pattern in azimuth and a directional Pattern in elevation “, An Omnidirectional is thus a special type of directional Pattern.

### 3.14 RADIATION PATTERN LOBES

The Various Parts of a radiation pattern are referred to as lobes, which may be subclassified into major, Minor, side and back lobes.

A radiation lobe is a “portion of the radiation pattern bounded by regions of relatively weak radiation intensity”.

A major lobe (also called main beam) is defined as “The radiation lobe containing the direction of maximum radiation. A minor lobe is any lobe except a major lobe. A side lobe is “a radiation lobe in any direction other than the intended lobe” A back lobe is

usually referred to a minor lobe that occupies the hemisphere in a direction opposite to that of the major lobe.

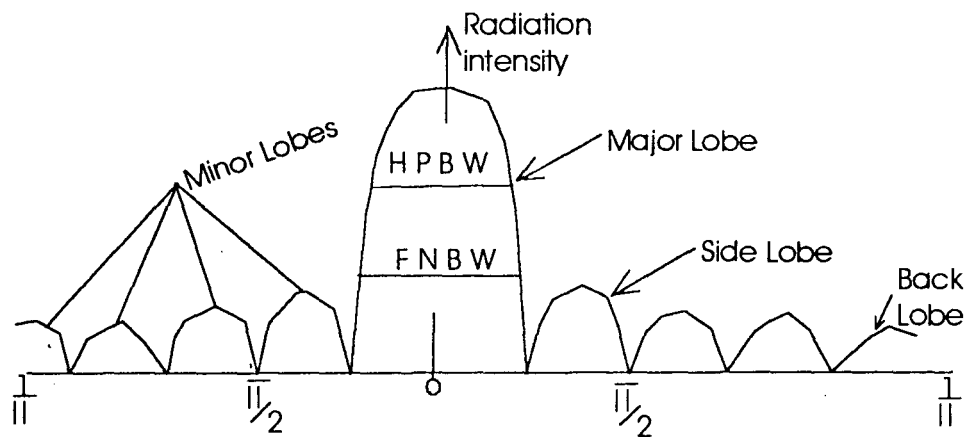

Half – power beam width (HPBW)

First null beam width (FNBW)

Figure 3.2 Linear plot of power pattern and its associated lobes and beam width.

### 3.15 RADIATION POWER

Electro magnetic Waves are used to transport information through a wireless medium or a guiding Structure, from one Point to the other. It is than natural to assume power and energy, which are associated with Electro magnetic fields. The quantity used to describe the power associated with an Electromagnetic wave is the instantaneous Poynting Vector defined,,

$$W = E \times H \text{ -----(1)}$$

W= Instantaneous Poynting Vector ( $w/m^2$ )

= In stantaneous Electric field Intensity (  $v/m$ )

H = Instantaneous magnetic field Intensity (A/m)

Since the Poynting Vector is a Power density, the total Power crossing a closed Surface is;

$$P = \iint w \cdot Ds = \iint w \cdot \bar{n} \, da \quad \text{---- (11)}$$

P = Instantaneous Total Power (w)

Da = Infinitesimal area of the Closed Surface (m) the time average Poynting Vector (average Power density) can be written as

$$W_{av}(x,y,z) = \{W(X,Y,Z)\}_{av} = \frac{1}{2} \text{Re} \{E \times H\} \quad (\text{w/m}^2) \quad \text{---(11)}$$

Based upon the definition of (iii), the average Power radiation by an antenna (radiation Power) can be written as;

$$P_{rad} = P_{av} = \iint W_{rad} \cdot ds = \iint W_{av} \cdot ds = \frac{1}{2} \iint \text{Re} (E \times H) \cdot ds \quad \text{Where}$$

P<sub>rad</sub> = radiation Power

P<sub>av</sub> = average Power radiated

W<sub>rad</sub> = radiation density

E = Electric field

H = magnetic field.

### 3.16 RADIATION INTENSITY.

Radiation Intensity in a given direction is defined as "the Power radiated from an antenna Per- unit solid angle". The radiation Intensity is a far-field Parameter, and it can be obtained by simply multiplying the radiation density by the square of the distance. In Mathematical form it is expressed as;

$$U = r^2 W_{rad}$$

Where u = radiation Intensity (w/unit solid angle)

W<sub>rad</sub> = radiation density (w/ms)

### 3.17 DIRECTIVITY

The definition of the directive gain has to be firstly considered for describing directivity gain in a given direction is defined as "the ratio of the radiation Intensity in that direction to the radiation Intensity of a reference antenna". The reference antenna is taken to be an isotropic source.

Directivity is " the Value of the directive gain in the direction of the Maximum Value ".

State more Simply, the directivity of anisotropic source is equal to the ratio of its Maximum radiation Intensity over that of an isotropic source, in mathematical form, it can be written as

$$D_g = \frac{U}{U_0} = \frac{4\pi U}{P_{rad}}$$

$$D_o = \frac{U_{max}}{U_0} = \frac{U_{max}}{U_0} = \frac{4\pi U_{max}}{P_{rad}}$$

$D_g$  = directive gain (dimensionless)

$D_o$  = directivity (dimensionless)

$U_{max}$  = Maximum radiation Intensity (w/unity solid angle)

$U_0$  =  $\frac{P_{rad}}{4\pi}$  = radiation Intensity of isotropic source (w/unity solid angle)

$U$  = radiation Intensity (w/unity solid angle)

$P_{rad}$  = Total radiated Power (w)

For an Isotropic source, the directive gain and directivity will be unity since  $U$ ,  $U_{max}$  and  $U_0$  are all equal to each other

### 3.18 GAIN

Another Useful measure describing the Performance of an antenna is the gain. Although the gain of the antenna is closely related to the directivity, it is a measure that takes into account the efficiency of the antenna as well as its directional capabilities while the directivity only describes the directional properties of the antenna, and it is therefor only Controlled by the Pattern.

Power gain of an antenna in a given direction is defined as "4<sup>th</sup> time the ratio of the radiation

Intensity in that direction to the net Power accepted by the antenna from a connected transmitter". When the direction is not stated, the power gain is usually taken in the directions of Maximum radiation, thus, in general

$$\text{Gain} = \frac{4\pi \text{ radiation Intensity}}{\text{Total input power}} = \frac{4\pi U(\theta, \phi)}{P_{in}}$$

Relative gain is defined as “the ratio of the Power gain in a given direction to the power gain of a reference antenna in its referenced direction”, the power input must be the same for both antennas.

The reference antenna is Usually an antenna whose gain can be Calculated or it is known in most cases, however, the reference antenna is a lossless isotropic source thus,

$$G_g = \frac{4\pi U(\theta, \phi)}{P_{in}} \text{ (dimensionless)}$$

Pin (lossless isotropic source)

### 3.1.9 ANTENNA EFFICIENCY

The total antenna efficiency is used to take into account losses at the input terminals and within the structure of the antenna. Such losses may be due to

- (1) Reflections because of the mismatch between the transmission or receiving line and the antenna
- (2) Losses (conduction and dielectric) in general the overall efficiency can be written as

$$e_t = e_r e_c e_d$$

Where

$e_t$  = total overall efficiency (dimensionless)

$e_r$  = reflection (mismatch) efficiency =  $(1 - |r|^2)$  (dimensionless)

$e_c$  = Conduction efficiency (dimensionless)

$e_d$  = dielectric efficiency (dimensionless)

$r$  = Voltage reflection coefficient at the input terminals of the antenna

$$[r = (Z_{in} - Z_0) / Z_{in} + Z_0]$$

Where

$Z_m$  = input impedance of the antenna

$Z_0$  = characteristic impedance of the transmission line or receiving line.



Usually  $e_c$  and  $e_d$  are very difficult to Compute. But they can be determined experimentally, Even by measurement they can not be seperated, and it is usually more convenient to write total efficiency as;

$$e_t = e_r e_{cd} = e_{cd} (1-r)^2$$

where:  $e_c = e_d =$  antenna radiation efficiencies

### 3.20 BANDWIDTH

The bandwidth of an antenna is defined as a'' the rang of frequencies within which the performance of the antenna, with respect to some characters, conforms to a specified standard''

The bandwidth can be considered to be the range of frequency, on either side of a center frequency, where the antenna characteristics (such as input, Impedance Pattern, beam width, Polarization, e.t.c) are with in an acceptable Value of those as the center frequency. For broad band antennas, the bandwidth is Usually expressed as the ration of the upper to lower frequencies of acceptable operation,

Because the characteristic (input impedance, Pattern, gain e.t.c) of an antenna do not necessarily Vary in the same manner or are even critically affected by the frequency, there is no unique characterization of the bandwidth

Accordingly Pattern band width and impedance band width are used to emphasize their distinction Associated with Pattern band width are gain, side lobe level, beamwidth, Polarization, and beam direction while input impedance and radiation efficiency are related to impedance band width.

### 3.2.1 POLARIZATION

Polarization of an antenna in a given direction is defined as "the Polarization of the radiated wave, when the antenna is excited, Alternately the Polarization of an incident wave from the given direction which results in maximum available power antenna terminals in ,Practice, Polarization of the radiated energy Varies with the direction from the center of the antenna, so that different Part of the Pattern may have different Polarization.

Polarization of a radiated wave is defined as "that Property of a radiated electromagnetic wave describing the time varying direction and relation Magnitude of the electric field Vector.

Polarization may be classified as Lines, Circular or elliptical, If the Vector that describes the electric field at a point in space as a function of time is always directed along a line, the field is said to be linearly Polarized. In general, however if the figure that shows the electric field traces is an ellipse, and the field is said to be elliptically Polarized. Line and Circular Polarization are especially cases of elliptical, and they can be obtained when the ellipse becomes a straight line or a Circle respectively.

### 3.21 INPUT IMPEDANCE

Input Impedance is defined as "the Impedance Presented by antenna at its terminals or the ratio of the Voltage to Current at a point of terminals or the ratio of the appropriate Components of the electric to Magnetic fields at a point " the input impedance at the terminals of the antenna is considered here below.

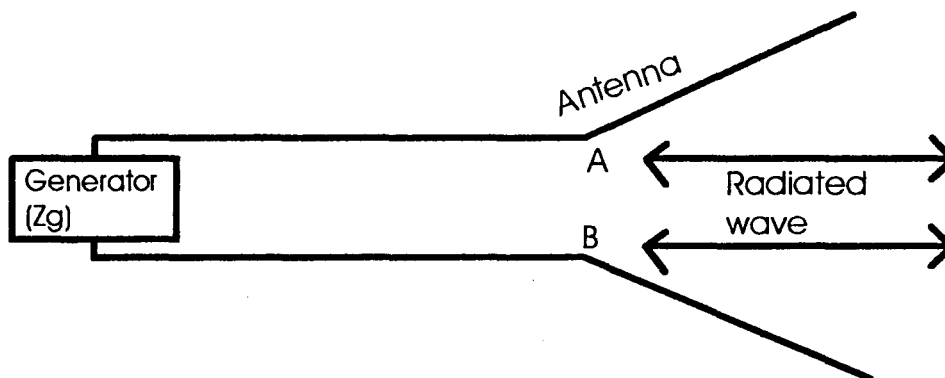

Figure 3.3 Antenna in transmitting or receiving mode

In figure 3.3, the terminals are designed as a – b , the ratio of the Voltage to Current at the terminals, with no load attached, defines the Impedance of the antenna as;  $Z_A = R_A + j X_A$  (Constantine A. Balanis - 1938)

Where  $Z_A$  = antenna impedance at terminals a-b (ohms)

$R_A$  = antenna resistance at terminals at a-b (ohms)

$X_A$  = antenna reactance at terminals a-b (ohms)

In general, the resistance Part consists of two Components; that is

$$R_A = R_r + R_l$$

Where  $R_r$  = radiation resistance of the antenna

$R_l$  = loss resistance of the antenna.

## CHAPTER FOUR

### DESIGN AND CONSTRUCTION OF A PARABOLIC ANTENNA OR REFLECTOR

#### 4.1 INTRODUCTION

Parabolic reflector is the one of the most widely used microwave antenna, The demands of reflector for Use in radio astronomy, microwave communication and Satellite tracking resulted inspectacular progress in the development of sorphisticated analytical and experimental techniques in shaping the reflector surfaces and optimizing illumination over their apertures so as maximize the gain. It has been shown by geometrical optics that if a beam of Parallel rays is incident upon a reflector whose geometrical shape is a parabola, the radiation will Converge (focus) at aspot which is Known as the focal point (for receiving antenna). In the same Manner, if a point source is placed at the focal point, the rays reflected by a parabolic reflector will emerge as a parallel beam.

Since the main objective of this project work is on receiving antenna, the former case shall be considered in this chapter.

#### DESIGN

#### SPECIFICATIONS

“A parabola is the Focus of a point that move in a Plane so that its distance from a fixed point (focus) in the Plane is equal to its distance form fixed straight line (directrix) in the Plane” The Parabolic antenna to be constructed was designed to have a circular surface area of about 0,283m, This is regarded as the effective area of the antenna which serves to receive the incident rays.

This is from the formula of an area of a circle.

$$A = \pi r^2 \dots\dots\dots 4.1$$

It implies that the radius  $r$  of the Parabolic disk is to be 0.3m in dimension while the diameter is to be 0.6m.

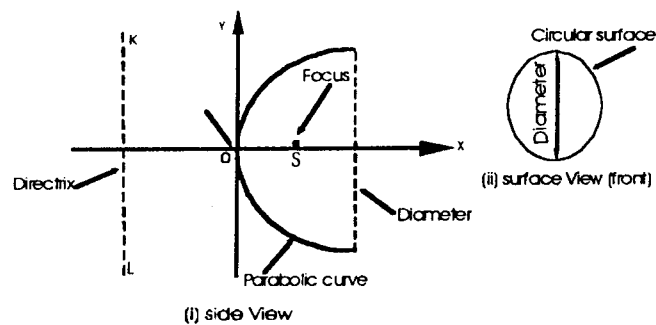

Fig. 4.1 Geometric design of the parabolic reflector.

As shown in fig 4.1 above,  $S$  (the fixed point) is the focus of the Parabola and  $KL$  (fixed straight Line) is the directrix. The point  $O$  which indicated the tip bottom of the Parabola is known as the Vertex.

From the specification, it Implies that the dimension of  $y$ -axis of the Parabolic disk. Is equal to 0.3m, which also represents the radius of the disk. Also; the dimension of  $x$ -axis

Which represent the actual depth of the disk Through the Vertex and the focal point is equal to 0.11 m

Now, Using the general equation of the Parabola

$$Y^2 = 4a X \quad \text{----- 4.2}$$

Where  $a$  is the focal point of the Parabola, the point of Convergence (focus) of all rays Incident on the surface area of the disk can be obtained as follows:

Knowing that

$$Y = 0.3\text{m}, x = 0.11$$

This implies that

$$(0.3)^2 = 4x a \times 0.11$$

$$0.09 = 0.449 a$$

$$a = \frac{0.09}{0.449} = 0.2045$$

$$0.44$$

$$9 = 0.20\text{m}$$

∴ The focal point of the parabolic reflector Under Construction is 0.20m

### REQUIREMENTS

In order to Construct the already designed Parabolic reflector described in this chapter, the following materials are required.

- (i) Square of black pipe
- (ii) Flat Iron sheet
- (iii) Cylindrical Iron pipe
- (iv) Coaxial cable
- (v) Nuts and bolts
- (vi) Aluminum rod
- (vii) Hollow rectangular Iron pipe
- (viii) Coupling transformer
- (ix) Diodes
- (x) Resistors
- (xi) Transistors

Fig. 4.2 Constructed Parabolic disk

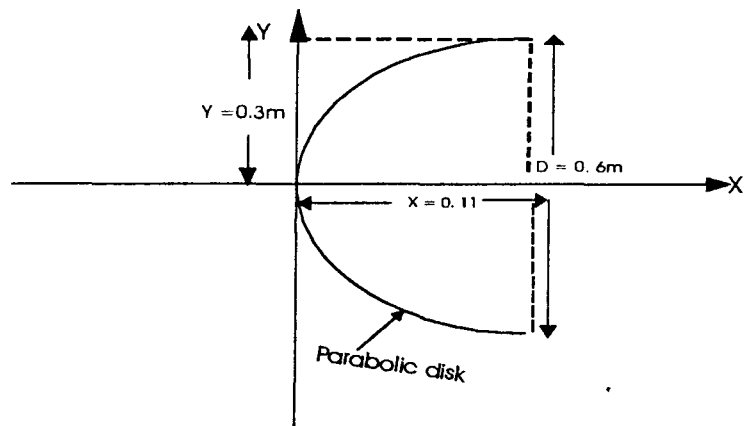

As shown in figure 4.2 the Construction of the designed parabolic reflector was began by bending and welding of square black iron pipe into semi Circle, and the square flat iron sheet was cut into 3 pieces with the aid of Cutter and welded into the pipe as specified in the design, a flat bar was welded to the Vertex of the

reflector, attached to the small hollow pipe also, to another flat bar downward with the help of long nuts and bolts for Varying the direction of the reflector in a Fixed Position, the hollow rectangular Iron pipe was welded at the flat bar to serve as a holding point for erective.cylindrical iron pipe which Stands the antenna in space for possible reception of waves, the Cylindrical Iron pipe in attached to the rectangular Iron pipe by with the aid of Knolt and bolts.

An aluminum rod was directed form the Vertex of the parabolic reflector and made to pass Through the focal point of the reflector. This rod will concentrate or Collect all the Incident waves at the focal point. A hollow Insulative Plastic rubber is used to isolate the bottom part of the rod from the body of the Parabolic reflector in other to avoid direct contact.

“ other components used are soldering Iron, soldering lead Multimeter tester, file meter rule, bread board, the component are arranged using the circuit diagram as reference, soldering Iron and soldering lead are used for joining of the component parts. Provision is made far the component part earthling for completion of the circuit.

### **CASING**

The casing of the unit is Constructed Using the flat sheet of wood cut to dimension to Protect the component part of the circuit.

The Construction is there fore Competed.

### **TESTING AND RESULT**

The Parabolic reflector was tested by connecting a coaxial cable from the terminal of the antenna (The tip of the aluminum dipole wire) to the terminals of the television set. The antenna held in space with the aid of erective cylindrical pipe. The direction of the antenna in space was varied by rotating the cylindrical pipe or the reflector it self the Intensity of the reception on the television was found to be brighter in some directions than the other. This simply, Indicate the effect of direct gain of the Parabolic reflector.

Also it was observed that the Intensity of the reception on the television depend on the height of the antenna in space and Partly on the geographical Location of where the antenna was tested. When the aluminum rod was deviated away from the focal point of the parabolic reflector it was observed that the Intensity of the reception on the television was reduced.

The point where there was brighter reception is Confirm to be the focal point agreed with the calculated Value.

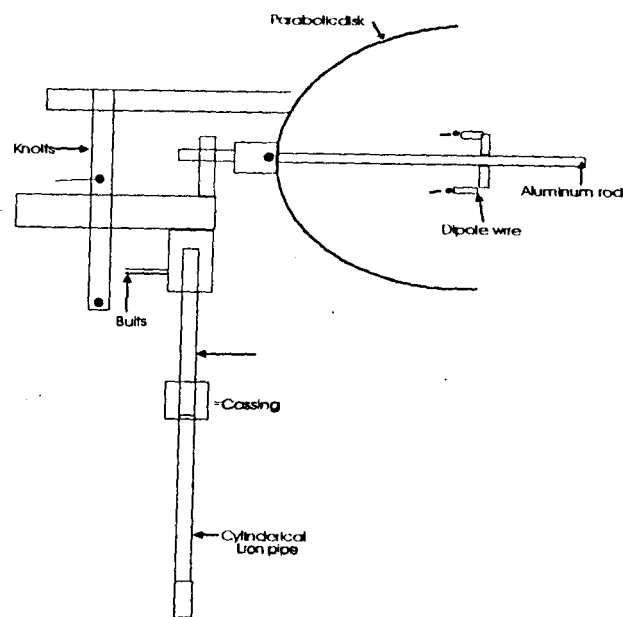



## CHAPTER FIVE

### DISCUSSION AND CONCLUSION

#### DISCUSSION

When a plane wave is imagined to incident upon the aperture as shown in figure 4.3 it is obvious that the Power received is equal to the Power density Multiplied by area of the aperture that is

$$\text{Perceived} = SA$$

Where S is the power density per unit area and A is the total effective area of the aperture.

The Construction of a Parabolic antenna is done with either a steel or aluminum as solid sheet surfaces. Steel is a popular choice, Particularly where weight is not a controlling factor. It is cheap and strong but is relatively difficult to form. Stainless steel or Plastic Coated galvanized steel are used when the surface must be resistant to corrosion. Aluminum is light in weight but is more expensive than steel Reflector surfaces may also be formed from fiber glass asbestos resinated laminate with the reflecting surface made of embedded mesh or metal spray, Plastic structure have the advantage of being light rigid and Capable of being made with highly accurate surface. The constructed parabolic antenna having a diameter of 0.60m implied a circular surface area of

$$\begin{aligned} A &= \pi r^2 \\ &= \frac{22}{7} \times 0.3 \times 0.3 \\ &= 0.283\text{m}^2 \end{aligned}$$

Where r is the radius of the Circular Surface this area is there for regarded as the Physical aperture area of the antenna which is another parameter related to the gain of the antenna. It may be regarded as a measure of the effective (apparent) area presented by the antenna to the on coming incident waves. The gain G and the effective area A. of a lossless antenna are related by

$$G = \frac{4\pi A_e}{\lambda^2}$$

$$= \frac{4\pi S_a A}{\lambda^2}$$

$$A_e = \eta_a A$$

Where  $\lambda$  = wave length of incident wave

A = Physical area of antenna

$\eta_a$  = Antenna aperture efficiency

From the relation, it implies that an increase in the effective area or aperture of the antenna will result in consequent high gain for the antenna. This can easily be achieved through increase in the physical area of the antenna.

The aperture efficiency is the ratio of the actual antenna directivity to the maximum possible directivity. Maximum directivity is achieved with a uniform aperture illumination.

An ideal antenna is one that will radiate or receive all the power delivered to it from the transmitter in a desired direction or directions in practice, however, such ideal performance can not be achieved but may be closely approached. Various types of antennas are available and each type can take different forms in order to achieve the desired radiation characteristic for the particular application.

## **CONCLUSION**

The Parabolic reflector had been designed and Constructed Using an iron sheet for Parabolic disk with a square black pipe welded to Support it at the back and an aluminum rod for the radiator. The antenna such Constructed when tested was found to be Capable of receiving NTA Minna

Parabolic reflector therefore serves as another useful and efficient method of collecting electromagnetic waves for clear transmission of information's. It design aid in long distances and space transmission and reception than other type of antennas.

## **RECOMMENDATION**

It is Interesting to under go Construction as engineering student. First degree final year Project. But the practical work entails a lot of sacrifice such as time and financial which are Inevitable.

More – so student of engineering in this Country should be introduced to a lot of practical work which I deem it fit that it will be of a great help during the final year project and even after leaving the school for their Various phase of engagement. The financing of the project is Very essential in the Sense that, Financial Constraint is a barrier to better Idea.

Lastly any body that may wish to work on this project should use the aluminum flat sheet for the construction of the parabola and copper wire for signal reception instead of aluminum rod.

## REFERENCES

- C.A Balaris, Antenna Theory (Analysis and Deign)  
John Willey and sons New York [ 1-734} 1982
- J.A IZYUMOV, Introduction to Radio Communication  
The comelot press Ltd. Southampton [96-125]1976
- R. L shrader, electronic communication  
Mc Grow -Hill Book company, New York  
[450-480] 1985
- R.S.G.B radio Communication Hand Book  
5<sup>th</sup> addition vol2
- R. knadle, kc2RW, in Twelve -foot stressed  
Parabolic dish Q St. August 1972  
Q St Febuary 1976.

