

DESIGN AND CONSTRUCTION OF A MICROCONTROLLER BASED DIGITAL COUNTDOWN TIMER WITH ALARM

OJO OLUWAFEMI TAYO

2005/22072EE

A PROJECT REPORT SUBMITTED TO THE
DEPARTMENT OF ELECTRICAL AND COMPUTER
ENGINEERING, FEDERAL UNIVERSITY OF TECHNOLOGY
MINNA

NOVEMBER, 2010.

DEDICATION

This project is dedicated to the almighty God, the giver of life for seeing me through my University education. To him i give all the honour and adoration for his faithfulness.

DECLARATION

I, OJO OLUWAFEMI TAYO declare that this work was done by me and has never been presented elsewhere for the award of a degree. I also hereby relinquish the copyright to the Federal University of Technology, Minna

OJO, OLUWAFEMI TAYO

MR J.A. AJIBOYE

.....
(Name of student)

.....
(Name of Supervisor)

 17/11/2010

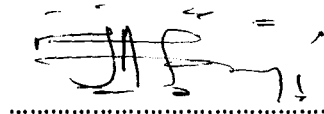
 17/11/10

(Signature and Date)

(Signature and Date)

ENGR. A.G RAI

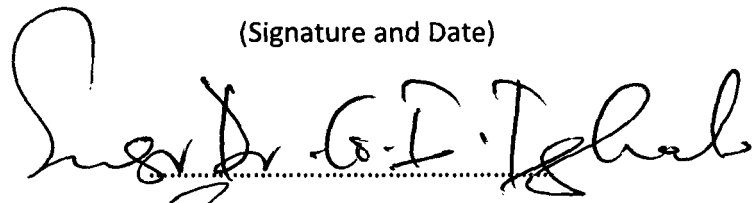

.....
(Name of H.O.D)

.....
(Name of External examiner)

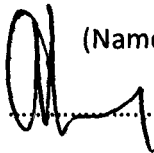
 (Jan 11, 2011)

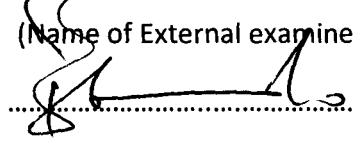
 9/12/10

(Signature and Date)

(Signature and Date)

ACKNOWLEDGEMENT

Special thanks go to almighty God to have provided me with enough strength and opportunity to have a university education. My sincere thanks goes to my parents, Mr. and Mrs. Gabriel Sanya Ojo for their parental care without which I would not have been able to pass through the system successfully. I will remain grateful and delightful forever. My thanks goes to my sisters, Folake, Ibijoke, and Ojo-Oluwa Ojo who have show their sisterly love, care and moral supports. To my uncle Mr. Ayodele Ayokunle Alabi, I say thank you sir for your supports. And to my cousin Olabode Aloko I say thank you too. I must not forget to say a big thank you to all my friends for supports and cooperation. Also to my mummy Mrs. Aniema Friday Umoh and family i say thank you. Mum, am very grateful. Not forgetting my sweetheart Mekuleyi Oluwakemi Olapeju for her love, care and supports throughout my stay here in school.

I gratefully acknowledge the effort of my supervisor Mr. J. A. Ajiboye, my H.O.D Eng. Raji for the standard been set up. I equally appreciate the effort of the entire staff of the school of Engineering particularly of Electrical and Computer Engineering department, Federal University of Technology Minna for giving me a strong basic foundation on electrical and electronics/computer field of practice. I thank you all.

ABSTACT

This project presents the design and construction of a digital countdown timer with alarm. An AT89C52 microcontroller IC belonging to the 8051 family was programmed as a real time clock. The digital countdown timer can count down from as high as two hundred and fifty six (256) days to zero seconds. When the countdown is completed it sounds an alarm, signalling the end of the countdown.

TABLE OF CONTENT

Dedication	i
Declaration	ii
Acknowledgement	iii
Abstract	iv
Table of Content	v
List of figures	vii
Chapter One: 1.0 Introduction	1
1.1 Aim and objective	3
1.2 Methodology	3
1.3 Scope and Limitation	4
1.4 Source of Material	4
1.5 Project Layout	4
Chapter Two: 2.0 Historical Background	6
2.1 History of Counting Systems and Numerals	6
2.2 Counters	9
2.3 Timers	12
Chapter Three 3.0 Block Diagram	16
3.1 Power Supply Unit	17
3.2 Keypad Unit	23

3.3 Microcontroller Unit	25
3.4 Output Unit	29
Chapter Four: 4.1 Testing	32
4.2 Case construction	33
4.3 Result and Discussion	34
Chapter Five: 5.0 Conclusions	35
5.1 Problem Encountered	35
5.2 Recommendations	36
References	37
Appendix	39

LIST OF FIGURES

FIGURE	PAGE
3.0 Block diagram	16
3.1 Power supply unit	17
3.2 Transformer	18
3.3 IN4001	19
3.4 Bridge rectifier	20
3.5 LM7805	20
3.6 Capacitor	21
3.7 Keypad	24
3.8 Common Keypad	25
3.9 Microcontroller Block diagram	26
3.10 AT89C52 pin function	28
3.11 Liquid crystal display	30
3.12 Complete circuit diagram	31
4.1 Final construction work	33

CHAPTER ONE

1.0 INTRODUCTION

The increase in the complexity of human activities has prompted measurement, hence time measurement. Timing has become an integral part of human daily activity. Time measurement is important in order to keep track of the periods allotted to various human activities. Time measurement can be carried out using wrist watch, stop watch, or a timer.

A countdown timer is a specialized type of clock. A countdown timer can be used to control the sequence of an event or process [1]. Whereas a stopwatch counts upwards from zero for measuring elapsed time, a countdown timer counts down from a specified time interval, like an hourglass. Timers can be mechanical, electromechanical, electronic (quartz), or even software as all modern computers include digital timers of one kind or another. When the set period expires some timers simply indicate so (e.g., by an audible signal using a buzzer or speaker), while others operate electrical switches [1].

A digital countdown timer is a timer with a digital display and a digital electronics which counts down from a specified time. Programmable digital countdown timers controlled launch sequence events in early rockets and ballistic missiles. As digital electronics has progressed and dropped in price, electronic timers have become more advantageous. The use of microcontroller to implement a digital countdown has further reduced the need for complex circuitries, making it easier to implement [2].

A digital countdown timer has the following advantages:

- ✓ It has greater precision
- ✓ Large displays can be obtained with matrix LED arrangement.
- ✓ It is environmental friendly since no smoke is emitted.
- ✓ Easy implementation.
- ✓ It is easy to operate and handle.
- ✓ It allow user to be aware of upcoming events.

In order to embrace technology in Nigeria and the world at large the microcontroller based digital countdown timer has been designed for use in homes, laboratories, hospitals, schools, kitchens and even in safety devices like the Gas timer [3]. A digital countdown timer has the following features:

- ✓ A 16x2 LCD-liquid crystal display
- ✓ An AT89S52 microcontroller programmable IC
- ✓ Keypad for inputs
- ✓ Power supply unit
- ✓ Back-light
- ✓ Automatic alarm

1.1 AIMS AND OBJECTIVES

The aim of this project is to use a microcontroller to implement a digital countdown timer. The alarm should sound when the countdown is completed.

The objectives of this project are as follows:

- ✓ To make time countdown very easy.
- ✓ To produce a cheaper and more affordable digital countdown timer.

1.2 METHODOLOGY

In carrying out this project, an assembly language program was written to perform the countdown. The HEX file for the source code was also generated and programmed onto a blank AT89S52 IC. The countdown operation and all other processes involved are entirely controlled by the microprocessor unit. In writing the program, care was taken to ensure that it was error free. Although this was a very difficult task which must be achieved before the HEX file was finally burned onto the AT89S52 IC. To achieve the countdown, the IC was also programmed as a real time clock.

Liquid crystal display is used to display the output. The input is from a key pad and made very flexible in that the time can be inputted in ddd:hh:mm:ss. An audible alarm will sound indicating the end of the countdown.

3 SCOPE AND LIMITATION

This project has been designed mainly to function as a countdown timer. It has the ability to count time in days, hours, minutes and seconds. The digital countdown timer counts down from a specified value down to zero then the alarm will sound to signify the end of the countdown. Therefore it cannot be used to function as a stopwatch. However in the case where it is intended to function as a stopwatch the AT89S52 IC can be reprogrammed; the AT89C51 is a low-power, high-performance CMOS 8-bit microcomputer with 8K bytes of Flash programmable and erasable read only memory (PEROM).

1.4 SOURCES OF MATERIAL

The materials used for this project work was sort for from within and outside Minna. Most of which was gotten from Lagos. Some resources were also gotten from the school and departmental library. Also the internet serves as a major resource bank for this project work.

1.5 PROJECT LAYOUT

CHAPTER ONE: This is the expository introduction to the project work. It contains the projects objectives, methodology, sources of material and the project layout.

CHAPTER TWO: Literature review and theoretical background forms the chapter two of this project work. It contains the necessary theoretical background, brief historical background, and the previous works in this area of study.

CHAPTER THREE: This is the design and implementation stage. Thus forming the major part of this project work. It contains the circuit diagram and explanation of each module, and all the components used.

CHAPTER FOUR: Testing, result and discussion forms the chapter four of this work. It also contains steps taken to test the work and the measurement method employed. The result is plotted or presented in tabular form as may be required.

CHAPTER FIVE: This is the summary of the whole work. The result obtained and problem encountered are summarized. Recommendations on how to improve the work are also stated.

REFERENCES: This contains all the list of books, magazines, journals, and websites that were read and cited inside then text of this report.

CHAPTER TWO

LITERATURE REVIEW /HISTORICAL BACKGROUND

2.0 HISTORICAL BACKGROUND

Soon after language develops, it is safe to assume that humans begin counting - and that fingers and thumbs provide nature's abacus. The decimal system is no accident. Ten has been the basis of most counting systems in history. When any sort of record is needed, notches in a stick or a stone are the natural solution. In the earliest surviving traces of a counting system, numbers are built up with a repeated sign for each group of 10 followed by another repeated sign for 1 [4].

The use of numbers and counting goes a long way back in time. One of the first methods of counting was Roman Numerals. Today, counting is something we use every day! Some people use counting to help make the food we eat, while some people use counting to see how many animals are on the earth and in the sea. Counting is important to understand and there are many activities we can do to help improve our counting skills [5].

2.1 HISTORY OF COUNTING SYSTEMS AND NUMERALS

2.1.1 Egyptian numbers: 3000-1600 BC

In Egypt, from about 3000 BC, records survive in which 1 is represented by a vertical line and 10 is shown as \wedge . The Egyptians write from right to left, so the number 23 becomes $\text{lll}\wedge$. If that looks hard to read as 23, glance for comparison at the name of a famous figure of our own century - Pope John XXIII. This is essentially the Egyptian system, adapted by Rome and still in

asional use more than 5000 years after its first appearance in human records. The scribes of Egyptian pharaohs (whose possessions are not easily counted) use the system for some very large numbers [6].

1.2 Babylonian numbers: 1750 BC

The Babylonians use a numerical system with 60 as its base. This is extremely unwieldy, since it should logically require a different sign for every number up to 59 (just as the decimal system does for every number up to 9). Instead, numbers below 60 are expressed in clusters of ten making the written figures awkward for any arithmetical computation. Through the Babylonian pre-eminence in astronomy, their base of 60 survives even today in the 60 seconds and minutes of angular measurement, in the 180 degrees of a triangle and in the 360 degrees of a circle. Much later, when time can be accurately measured, the same system is adopted for the subdivisions of an hour [7].

The Babylonians take one crucial step towards a more effective numerical system. They introduce the place-value concept, by which the same digit has a different value according to its place in the sequence. We now take for granted the strange fact that in the number 222 the digit '2' means three quite different things - 200, 20 and 2 - but this idea is new and bold in Babylon. For the Babylonians, with their base of 60, the system is harder to use. For them a number as simple as 222 is the equivalent of 7322 in our system ($2 \times 60^2 + 2 \times 60 + 2$).

The place-value system necessarily involves a sign meaning 'empty', for those occasions where the total in a column amounts to an exact multiple of 60. If this gap is not kept, all the digits before it will appear to be in the wrong column and will be reduced in value by a factor of 60 [7].

2.1.3 The abacus: 1st millennium BC

In practical arithmetic the merchants have been far ahead of the scribes, for the idea of zero is in use in the market place long before its adoption in written systems. It is an essential element in humanity's most basic counting machine, the Abacus. This method of calculation - originally simple furrows drawn on the ground, in which pebbles can be placed - is believed to have been used by Babylonians and Phoenicians from perhaps as early as 1000 BC. In a later and more convenient form, still seen in many parts of the world today, the abacus consists of a frame in which the pebbles are kept in clear rows by being threaded on rods. Zero is represented by any row with no pebble at the active end of the rod [8].

2.1.4 Roman numerals: from the 3rd century BC

The completed decimal system is so effective that it becomes, eventually, the first example of a fully international method of communication. But its progress towards this dominance is slow. For more than a millennium the numerals most commonly used in Europe are those evolved in Rome from about the 3rd century BC. They remain the standard system throughout the Middle Ages, reinforced by Rome's continuing position at the centre of western civilization and by the use of Latin as the scholarly and legal language [9].

2.1.5 Binary numbers: 20th century AD

Our own century has introduced another international language, which most of us use but few are aware of. This is the binary language of computers. When interpreting coded material by means of electricity, speed in tackling a simple task is easy to achieve and complexity merely complicates. So the simplest possible counting system is best, and this means one with the lowest

ossible base - 2 rather than 10. Instead of zero and 9 digits in the decimal system, the binary system only has zero and 1. So the binary equivalent of 1, 2, 3, 4, 5, 6, 7, 8, 9, 10 is 1, 10, 11, 100, 101, 110, 111, 1000, 1001 and 1010 and so ad infinitum [10].

2.2 COUNTERS

Digital counters are integrated circuits that count events in computers and other digital system. Because they must remember past states, digital counters include memory. Generally digital counter consist of bistable devices or bistable multivibrators called flip-flops. The ways in which devices are clocked determine whether digital counters are categorized synchronous or asynchronous. In synchronous devices, one clock triggers all the flip flops simultaneously with asynchronous or ripple counters an eternal clock pulse triggers only the first flip-flop. Each successive flip-flop is then clocked by one of the outputs of the previous flip-flop. Some digital counter can operate either synchronously or asynchronously. Devices can counter in an increasing sequence, a decrease sequence or in either increasing or decreasing sequences [11].

Several types of digital counters are available they include

- i. Johnson counter
- ii. Decade counter
- iii. Up-down counters
- iv. Ring counter

2.2.1 Johnson counters

A Johnson counter is a special case of shift register where the output from the past stage is inverted and fed back as input to the first stage. A pattern of bits equal in length to the shift register thus circulates indefinitely. These counters are sometimes called "walking ring" counters and find specialist application including those similar to the decade counter, digital to analogue conversion [12].

2.2.2 Decade counters

Decade counters are a kind of counter that counts in tens rather than having a binary representation. Each output will go high in turn, starting over after ten outputs have occurred (then all the flip-flops are cleared/ reset). These types of circuit find application in multiplexers and demultiplexers or wherever a scanning type of behavior is useful [13].

2.2.3 Up-Down Counters

It is a combination of up counter and down counter counting in straight binary sequences. There is an up-down selector. If this value is kept high, the counter increments binary value and if the value is low, the counter starts decrementing the count. Down counters are made by using the complemented inputs to act as the clock for the next flip-flop in the case of an asynchronous counter. An up counter is constructed by linking the Q out of the J-K flip-flop and putting it into a negative edge triggered clock input [14].

2.2.4 Ring counters

A ring counter is a counter that counts up and when it reaches the last number that is designed to count up to it will reset itself back to the first number for example a ring counter that

designed using 3JK Flip-flop will count starting from 001 to 010 to 100 and back to 001. it will repeat itself in a ring slope and thus the name ring counter is given [15].

2.2.5 Infrared and optical counters

There are three types of infrared beam counter: passive, target reflective, and active.

2.2.6 Passive infrared counter (PIR)

The passive infrared counter operates by detecting the body heat of individual in close proximity to the machine (usually no greater than 4meters) Due to the small area covered by the beam this type of counts needs to be located very close to the path which make concealment difficult, particularly in an upland setting. Extreme (hot and cold) can impinge on the effectiveness of these types of counter and there is a tendency to undercount large groups walking closely together. Cyclists may be counted; dependent on the speed traveled. As with most counters, exempting the example metal detecting ones for bicycles and cars large animals such as deer and cattle can trigger these counters [16].

2.2.7 Target reflective infrared counter (TR)

A recent development these devices emit non-laser focused infrared pulse and measure the strength of the reflected signal. The TR bounces the infrared off people vehicles, bikes and can be used for any or all of them. They behave like radar and have a range of around 6 meters. They do used reflectors hence do not self count and are not affected by extremes of temperature like PIR nor do they count deer and cattle however, the small range may means that there are problem into concealing the equipment [16].

2.8 Active Infrared counter (AIR)

They operate up to a range of around 30 meters either by emitting a constant beam to a reflector that bounces the beam back to the machine (retro-reflective) or by having a separate transmitter and receiver each with a power supply when the beam is interrupted by a solid object passing it, a count is triggered for an active infrared sensor. Power supply should be a consideration if no mains supply is available counter will require either solar panel or quite heavy car types batteries which need to be exchanged and recharged for example monthly [17].

2.3 TIMERS

A timer is a specialized type of clock. A timer can be used to control the sequence of an event or process. Whereas a stopwatch counts upwards from zero for measuring elapsed time, a timer counts down from a specified time interval, like an hourglass. Timers can be mechanical, electromechanical, electronic (quartz), or even software as all modern computers include digital timers of one kind or another. When the set period expires some timers simply indicate so (e.g., by an audible signal), while others operate electrical switches [1].

Several types of digital counters are available they include:

- i. Mechanical timers
- ii. Electromechanical timers
- iii. Electronic timers
- iv. Computer timers

2.3.1 Mechanical timers

Mechanical timers regulate their speed. Inaccurate, cheap mechanisms use a flat beater that spins against air resistance. Mechanical egg-timers are sometimes of this type. More accurate mechanisms have mechanisms similar to mechanical alarm clocks; they require no power, and can be stored for long periods of time. The most widely-known application is to control explosives [18].

2.3.2 Electromechanical timers

Short-period bimetallic electromechanical timers use a thermal mechanism, with a metal finger made of strips of two metals with different rates of thermal expansion sandwiched together; steel and bronze are common. An electric current flowing through this finger causes heating of the metals, one side expands less than the other, and an electrical contact on the end of the finger moves away from or towards an electrical switch contact. The most common use of this type is in the "flasher" units that flash turn signals in automobiles, and sometimes in Christmas lights. This is a non-electronic type of multivibrator.

An electromechanical cam timer uses a small synchronous AC motor turning a cam against a comb of switch contacts. The AC motor is turned at an accurate rate by the alternating current, which power companies carefully regulate. Gears drive a shaft at the desired rate, and turn the cam. The most common application of this timer now is in washers, driers and dishwashers. This type of timer often has a friction clutch between the gear train and the cam, so that the cam can be turned to reset the time. Electromechanical timers survive in these

lications because mechanical switch contacts may still be less expensive than the semiconductor devices needed to control powerful lights, motors and heaters.

In the past these electromechanical timers were often combined with electrical relays to create electro-mechanical controllers. Electromechanical timers reached a high state of development in the 1950s and 60s because of their extensive use in aerospace and weapons systems. Programmable electromechanical timers controlled launch sequence events in early rockets and ballistic missiles. As digital electronics has progressed and dropped in price, electronic timers have become more advantageous [2].

2.3.3 Electronic timer

Electronic timers are essentially quartz clocks with special electronics, and can achieve higher precision than mechanical timers. Electronic timers have digital electronics, but may have an analog or digital display. Integrated circuits have made digital logic so inexpensive that an electronic timer is now less expensive than many mechanical and electromechanical timers. Individual timers are implemented as a simple single-chip computer system, similar to a watch and usually using the same, mass-produced, technology.

Many timers are now implemented in software. Modern controllers use a programmable logic controller rather than a box full of electromechanical parts. The logic is usually designed as if it were relays, using a special computer language called ladder logic. In PLCs, timers are usually simulated by the software built into the controller. Each timer is just an entry in a table maintained by the software [3].

4 Computer timers

Computer systems usually have at least one timer. These are typically digital counters that either increment or decrement at a fixed frequency, which is often configurable, and that interrupt the processor when reaching zero, or a counter with a sufficiently large word size that it will not reach its counter limit before the end of life of the system.

More sophisticated timers may have comparison logic to compare the timer value against a specific value, set by software, which triggers some action when the timer value matches the pre-set value. This might be used, for example, to measure events or generate pulse width modulated waveforms to control the speed of motors (using a class D digital electronic amplifier).

As the number of hardware timers in a computer system or processor is finite and limited, operating systems and embedded systems often use a single hardware timer to implement an extensible set of software timers. In this scenario, the hardware timer's interrupt service routine would handle house-keeping and management of as many software timers as are required, and the hardware timer would be set to expire when the next software timer is due to expire. At expiry, the interrupt routine would update the hardware timer to expire when the next software timer is due, and any actions would be triggered for the software timers that had just expired. Expired timers that are continuous would also be reset to a new expiry time based on their timer interval, and one-shot timers would be disabled or removed from the set of timers. While simple in concept, care must be taken with software timer implementation if issues such as timer drift and delayed interrupts is to be minimized [19].

CHAPTER THREE

DESIGN AND IMPLEMENTATION

This design can be divided into four (4) major unit or parts. These subdivisions are as follows:

- a. Power supply unit
- b. Keypad unit
- c. Microcontroller unit
- d. Display unit

3.0 BLOCK DIAGRAM

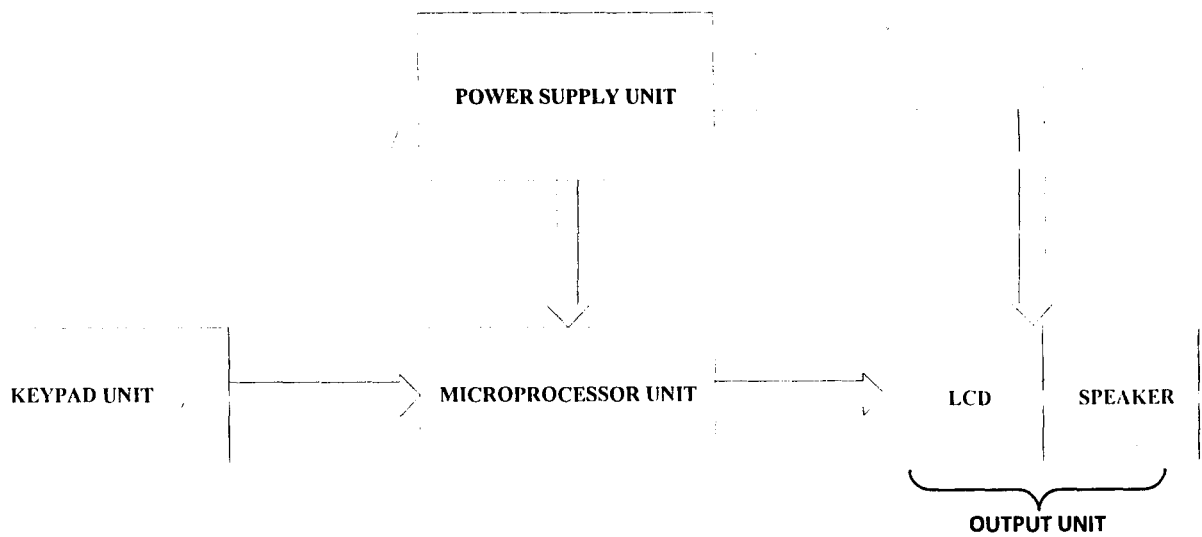

Fig. 3.1 Block diagram

1 POWER SUPPLY UNIT

The power supply from the AC mains is being stepped down to 12V AC by a step down transformer. The 12V AC is rectified into DC using a bridge rectifier.

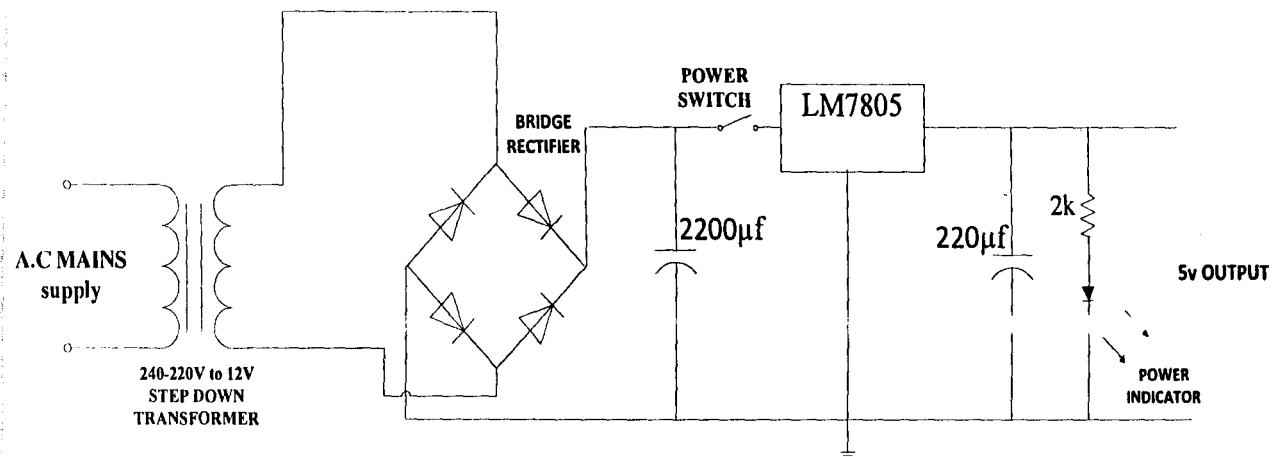

Fig. 3.1 Power supply unit

3.1.1 TRANSFORMER

A transformer is an electrical AC component or equipment which consists of two or more coils that are linked together by mutual inductance. It is used to transfer electrical power from one coil to another. It can be used to change voltage, current, or impedance from one value to another.

Power is applied to the transformer through one of the coil which is known as the PRIMARY winding. Power is taken from another coil known as the SECONDARY winding. The primary winding converts the electrical energy into magnetic energy while the secondary winding converts the magnetic energy back to electrical energy. The two winding are, therefore, magnetically coupled but electrically insulated from each other.

Two types of transformer construction are available. These are:

- ✓ Core-type
- ✓ Shell-type

In the core-type transformer, a single magnetic circuit is used. In the shell-type, a double magnetic circuit is used [19].

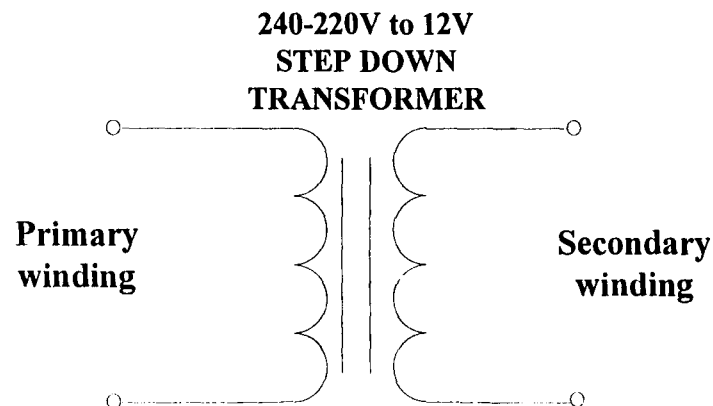

Fig. 3.2 Transformer

3.1.2 IN4001 RECTIFYING DIODE

In electronics, a diode is a two-terminal electronic component that conducts electric current in only one direction. The term usually refers to a semiconductor diode, the most common type today. This is a crystalline piece of semiconductor material connected to two electrical terminals. The most common function of a diode is to allow an electric current to pass in one direction (called the diode's forward direction) while blocking current in the opposite direction (the reverse direction). Thus, the diode can be thought of as an electronic version of a

check valve. This unidirectional behavior is called rectification, and is used to convert alternating current to direct current, and to extract modulation from radio signals in radio receivers [20].



Fig. 3.3 IN4001 diode

3.1.3 BRIDGE RECTIFIER

A four-diode rectifier circuit shown below serves very nicely to provide full-wave rectification of the ac output of a single transformer winding. The diamond configuration of the four diodes is the same as the resistor configuration in a Wheatstone bridge. In fact, any set of components in this configuration is identified as some sort of bridge, and this rectifier circuit is similarly known as a bridge rectifier [21].

The rectifier circuit requires two diodes to be forward biased in every half cycle of the input alternating voltage or current while the other is cut-off through reverse biased. Then the early cut-off diode comes active while the others are cut-off [22].

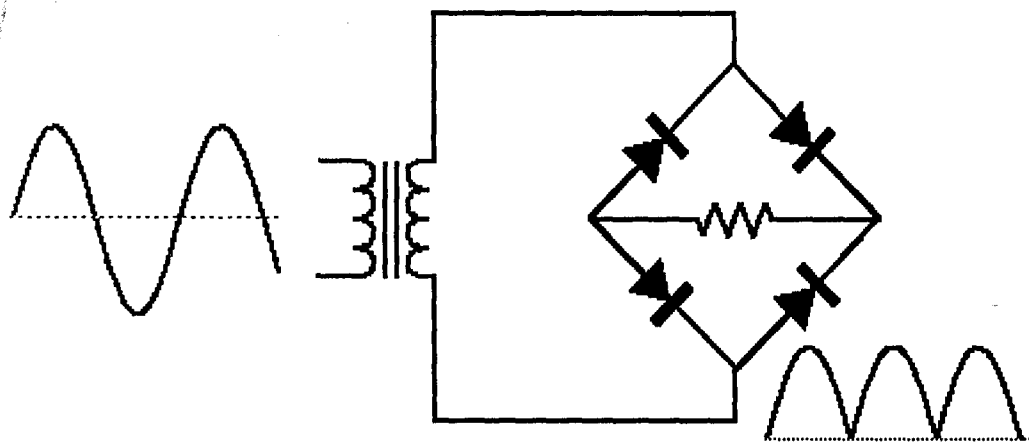

Fig. 3.4 Bridge rectifier

3.1.4 LM7805 REGULATOR

The LM7808 is a three-terminal positive voltage regulators employ built-in current limiting, thermal shutdown, and safe-operating area protection which makes them virtually immune to damage from output overloads. With adequate heat sinking, they can deliver in excess of 0.5A output current. Typical applications would include local (on-card) regulators which can eliminate the noise and degraded performance associated with single-point regulation [23]. LM7805 regulates the 12V DC to 5V and provide a stable power supply to the microprocessor (with 4V to 5.2 operating range) and the display unit.

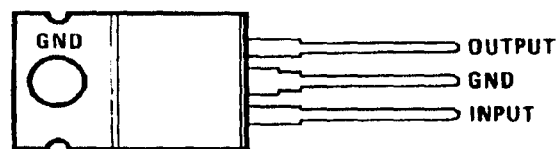

Fig. 3.5 LM7805

3.1.5 CAPACITOR

A capacitor (formerly known as condenser) is a passive electronic component consisting of a pair of conductors separated by a dielectric (insulator). When there is a potential difference (voltage) across the conductors a static electric field develops in the dielectric that stores energy and produces a mechanical force between the conductors. An ideal capacitor is characterized by a single constant value, capacitance, measured in farads. This is the ratio of the electric charge on each conductor to the potential difference between them.

Capacitors are widely used in electronic circuits for blocking direct current while allowing alternating current to pass, in filter networks, for smoothing the output of power supplies, in the resonant circuits that tune radios to particular frequencies and for many other purposes [24].

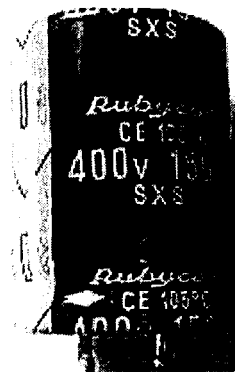

Fig. 3.6 Capacitor

A 2200 μ F 25V capacitor is placed in parallel to the bridge rectifier. This capacitor filters ripples or residual A.C components in the output of the rectifier. The resulting ripple voltage (dc) can be calculated.

The load causes the capacitor to discharge between half cycles. If the load current stays constant, as it for small ripple, then

$$I = C \frac{dv}{dt} \quad \text{equation 3.1}$$

The frequency of the full wave signal is double the input frequency. The full wave rectifier inverts each negative half cycle, so that we get double the number of positive half cycles.

The effect is to double the frequency.

Therefore,

$$f_{\text{out}} = 2f_{\text{in}} \quad (\text{I.e. twice the value of the input}) \quad \text{equation 3.2}$$

$$dt = \frac{1}{2f_{\text{in}}} \quad \text{equation 3.3}$$

$$= \frac{1}{2 \times 50}$$

The maximum current that can be drawn by the main circuit is determined by the voltage regulator following the filtering capacitor, the 7805.

The standard 7800 series can produce output current in excess of 1A when used with adequate heat sink. Therefore, it can supply a maximum of 1A. This current will be drawn from the supply. Thus $I_{\text{load}} = 1\text{A}$ (maximum). The value of capacitance C can be calculated from

$$C = I \frac{dt}{dv} \quad \text{equation 3.4}$$

But generally, dv which is the ripple voltage is chosen to be 30% of V_P where V_P is the peak voltage.

$$\text{Therefore, } V_P = V_{\text{rms}} \sqrt{2} \quad \text{equation 3.5}$$

Where $V_{\text{rms}} = 12\text{V}$, since the transformer of 220/12V was used

$$V_P = 12\sqrt{2} = 16.94\text{V}$$

For bridge rectifier, $V_{P(out)} = 12\sqrt{2} - 1.4$

$$= 16.97 - 1.4 = 15.57V$$

$$dv = \frac{30}{100} \times 15.57 = 4.67V$$

$$\text{Therefore, } C = \frac{1 \times 0.01}{4.67} = 2.141 \times 10^{-3}F$$

$$= 2,141\mu F$$

Therefore a commercial value of $2,200\mu F$, 25V was used in order to reduce the ripple to the nearest minimum. Then the expected ripple voltage using this value of capacitor is

$$dv = \frac{1 \times 0.01}{2200} = 4.55V$$

This means that the output wave form goes from peak value of 15.57V to $(15.57 - 4.55 = 11.02V)$. It may be noted that the input voltage to the IC regulator must be at least 2V above the output voltage. This is required in order to maintain regulation.

Therefore, the peak value of 15.57V to 11.02V is acceptable since the output voltage is 5V.

The ripple is neglected by the 7805 to a negligible value.

The average voltage going to 7805 is calculated by

$$V_p - 0.5dv = 15.57 - 0.5 \times 4.55$$

$$= 13.30V$$

A $220\mu F$ capacitor is placed after the regulator to completely filter the output from the regulator.

3.2 KEYPAD UNIT

A keypad is a set of buttons arranged in a block or "pad" which usually bear digits and other symbols and usually a complete set of alphabetical letters. If it mostly contains numbers then it can also be called a *Numeric Keypad*. Keypads are found on many alphanumeric keyboards and on other devices such as calculators, push-button telephones, combination locks, and digital door locks, which require mainly numeric input [25].

1	2 ABC	3 DEF
4 GHI	5 JKL	6 MNO
7 PQRS	8 TUV	9 WXYZ
	0	

Fig. 3.7 Keypad

There are several different key pads in use today. Essentially, there is the American (Ma Bell) classic, the new ITU/ANSI/ISO/IEC standard, and one former standard each for the UK and Australia. Then, (it probably seemed like a good idea at the time) mobile phone manufacturers invented a whole bunch of new ones.

Fortunately, there is a standard (ITU E.161, also known as ANSI T1.703-1995/1999, and ISO/IEC 9995-8:1994), and most phones built today place letters on the phone key pad according to that standard [18]. The following table shows how the most common touch tone key pads map letters to numbers:

	1	2	3	4	5	6	7	8	9	0
International Standard	ABC	DEF	GHI	JKL	MNO	PQRS	TUV	WXYZ		
North American Classic	ABC	DEF	GHI	JKL	MN	PRS	TUV	WXY		
Australian Classic	QZ	ABC	DEF	GHI	JKL	MNO	PRS	TUV	WXY	
UK Classic	ABC	DEF	GHI	JKL	MN	PRS	TUV	WXY	OQ	
Mobile 1	ABC	DEF	GHI	JKL	MN	PRS	TUV	WXY	OQZ	

Fig. 3.8 Common keypads

There exist a number of variations on these key pads, mostly involving the use of the letters I, O, Q, and Z and the numbers 1 and 0 [24].

The keypad is connected to port 0 (zero) of the microcontroller. Port 0 (zero) of the microcontroller can be used both as address line and data line. When used as data line (fetch data) an external pull up resistance is required.

Therefore the value of external pull-up resistance can be calculated thus:

$$R = \frac{5v}{I_s} \quad \text{equation 3.6}$$

Where $I_s = 0.65\text{mA}$, which is the is the sinking current of the microcontroller.

$$R = \frac{5v}{0.65 \times 10^{-3}}$$

$$= 7,692\mu F$$

Therefore a commercial value of $10\text{K}\Omega$ was used for the design.

3.3 MICROCONTROLLER UNIT

A microcontroller is a single chip that contains the processor (the CPU), non-volatile memory for the program (ROM or flash), volatile memory for input and output (RAM), a clock and an I/O control unit. Also called a "computer on a chip," billions of microcontroller units (MCUs) are embedded each year in a myriad of products from toys to appliances to automobiles. For example, a single vehicle can use 70 or more microcontrollers. The microprocessor used for this project AT89S52 and it belongs to the 8051 family [25].

The picture below describes a general block diagram of microcontroller.

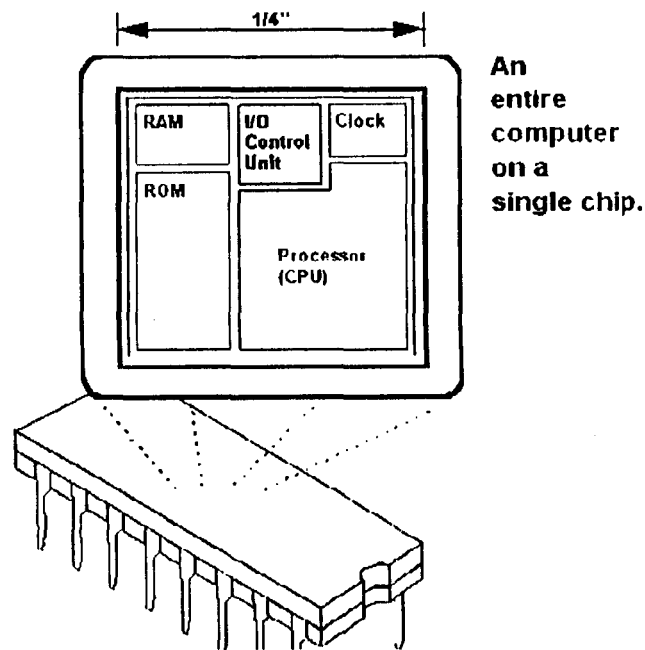

Fig. 3.9 Microcontroller Block diagram

3.3.1 AT89S52

The AT89S52 is a low-power, high-performance CMOS 8-bit microcontroller with 8K bytes of in-system programmable Flash memory. The device is manufactured using Atmel's high-density nonvolatile memory technology and is compatible with the industry-standard 80C51 instruction set and pin out. The on-chip Flash allows the program memory to be reprogrammed in-system or by a conventional nonvolatile memory programmer. By combining a versatile 8-bit CPU with in-system programmable Flash on a monolithic chip, the Atmel AT89S52 is a powerful microcontroller, which provides a highly flexible and cost-effective solution to many, embedded control applications [26].

The pin function diagram of the 8051 microcontroller shows all of the input/output pins unique to these microcontrollers family:

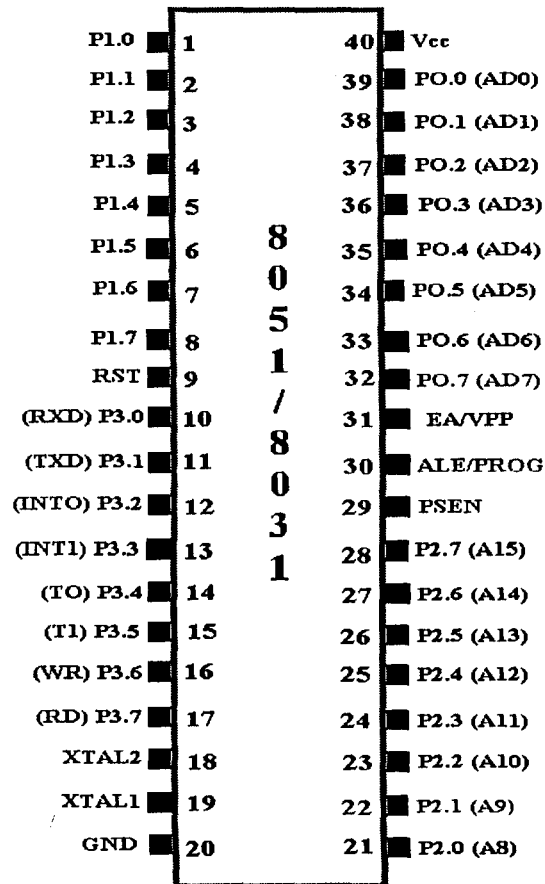

Fig.3.10 AT8952 Pin Function

The 8051 architecture consists of these specific features:

- ✓ 16 bit PC & data pointer (DPTR)
- ✓ 8 bit program status word (PSW)
- ✓ 8 bit stack pointer (SP)
- ✓ Internal ROM 4k
- ✓ Internal RAM of 128 bytes.

- ✓ 4 register banks, each containing 8 registers
- ✓ 80 bits of general purpose data memory
- ✓ 32 input/output pins arranged as four 8 bit ports: P0-P3
- ✓ Two 16 bit timer/counters: T0-T1
- ✓ Two external and three internal interrupt sources Oscillator and clock circuits.

3.4 OUTPUT UNIT

The output unit is made up of both an audio part and a visual part. The audio part sounds an alarm using a buzzer when the countdown is completed. The visual part displays the countdown time on an LCD (liquid crystal display). The LCD is of utmost importance in this project, because it's the major component communicating with the microcontroller. A liquid crystal display (LCD) is a thin, flat electronic visual display that uses the light modulating properties of liquid crystals (LCs). LCs does not emit light directly. They are used in a wide range of applications including: computer monitors, television, instrument panels, aircraft cockpit displays, signage, etc. They are common in consumer devices such as video players, gaming devices, clocks, watches, calculators, and telephones.

In choosing an LCD, utmost care was taken in selecting one that conformed to the popular HD44780U standard. For this project, the LCD is meant to only be written, therefore PIN 5 of the LCD was grounded, because When RW (PIN 5) is low (0), the information on the data bus is being written to the LCD. PIN 3 which is the contrast to the VCC via a variable resistor which serves as the contrast resistor.

For this project, the LCD was connected to display in 4-bits mode, which requires 7 lines (i.e. 4 data lines plus 3 control lines). In essence, it can be said that only 6 lines were used, because the PIN 5 was grounded.

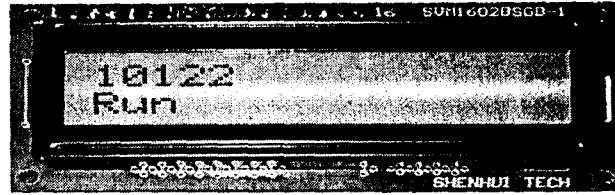

Fig.3.11 Liquid crystal display

The audio output comprises of buzzer which automatically sounds an alarm when the countdown is completed. A direct current buzzer was used for the alarm system since DC was the required form of voltage to power the circuitries.

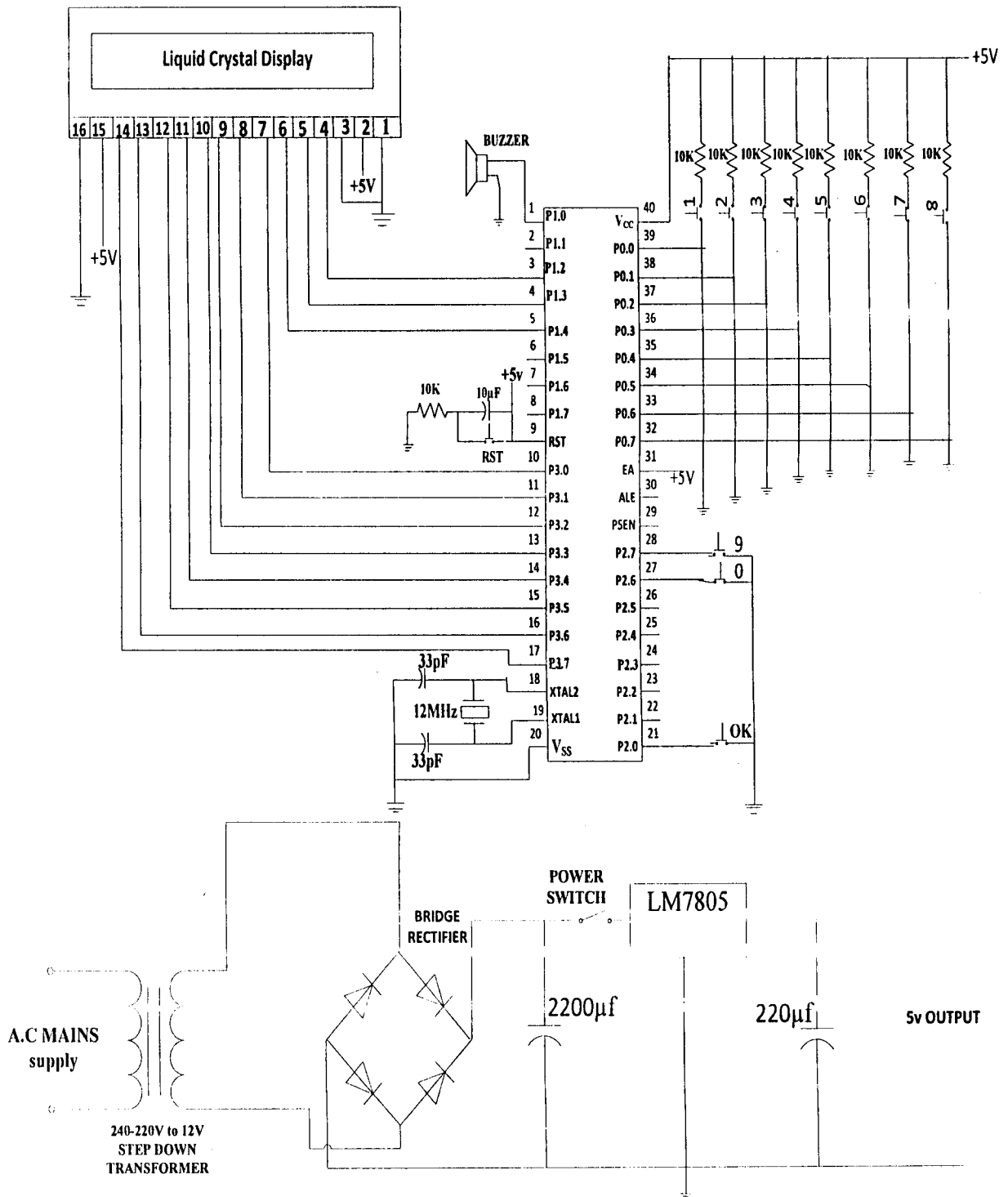

Fig. 3.11 Complete circuit diagram

CHAPTER FOUR

4.0 TESTS, RESULTS AND DISCUSSION

4.1 TESTING

The components needed for the construction were acquired and tested with a digital multi-meter to ensure that they are in good working condition and also confirm their individual values. The project work was first bread-boarded and tested to ensure that it's in good working condition. The testing was carried out module after module. When it was ensure that each module was working fine on bread board, then all the individual modules was then the coupled together. The bread board testing was done through a 9V DC supply from a battery which was stepped down to 5V which is the required voltage. After the bread-board testing and it was ensured that it worked properly, the whole work was then transferred to Vero-board.

The connections of the circuitry were done on the Vero-board by means of lead soldering and jumper wires. After the soldering work was completed on the Vero-board it was tested to ensure its working. After all connections were ensured to be in order, the set up was powered. A particular time to be counted down was inputted. The sound of the alarm indicated that the countdown process was completed. It therefore confirmed that it is working fine. The process was repeated for several time input to test its workability.

4.2 CASE CONSTRUCTION

A transparent plastic material was used to construct a case for this project work. The choice of plastic was necessary in order to achieve a light weight and also to add beauty to the design work.

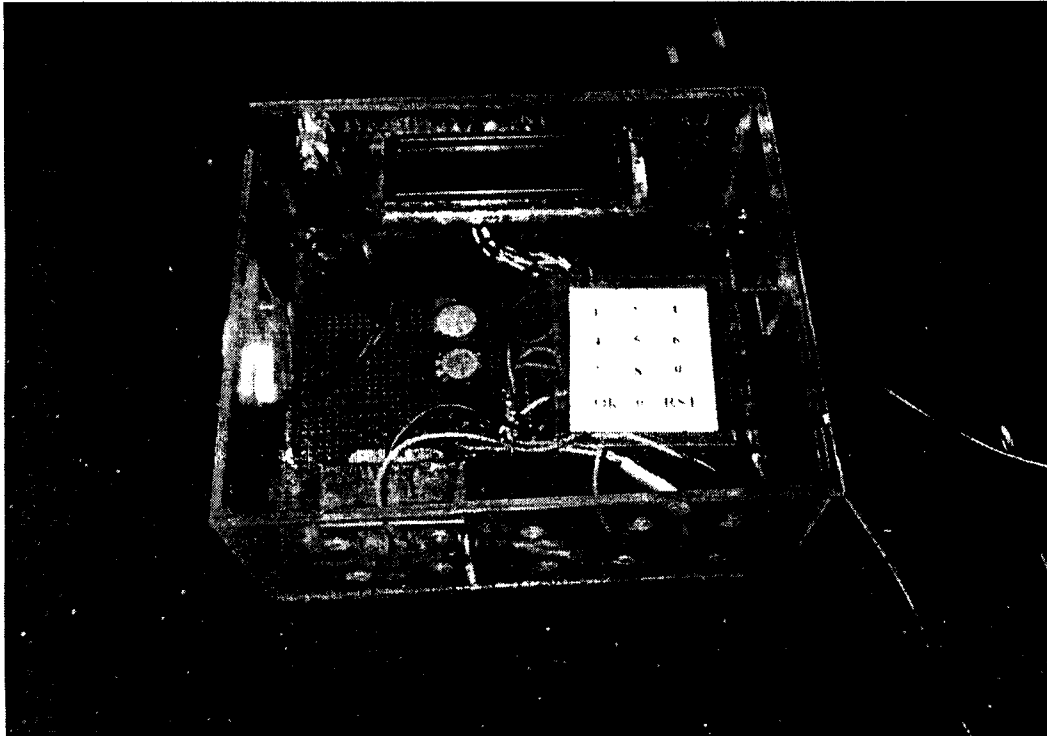

Fig. 4.1 Final construction work.

4.3 RESULT AND DISCUSSION

The countdown process was monitored by a real time to test its accuracy. For the various time inputs it was found that the digital countdown timer worked accurately. A real time was started at the same time with the digital countdown timer and it was noted that both timers completed their counts at the same time. Therefore from our observations it was seen that the digital countdown timer has the desired accuracy.

CHAPTER FIVE

5.0 CONCLUSIONS

This digital countdown timer keeps track of time from a low value of units of seconds to high of hundreds of days with a fair accuracy. There are extra features like automatic alarm, keypad input, RTC based, time keeping and backlight. This digital countdown timer counts down from as high as 256 days to zero seconds accurately. So this digital countdown timer is multipurpose. It can be use at many places and it has a very high durability.

5.1 PROBLEM ENCOUNTERED

- i. The most evident difficulty encountered in the course of this project work was in writing the assembly language program for the AT89S52 microcontroller where external assistance was sort in order to achieve successful result.
- ii. Troubleshooting the assembly language program was another problem that was encountered in the course of this project.
- iii. There was problem sourcing for materials needed for this project work, but was later overcome.

5.2 RECOMMENDATIONS

- i. A real time clock can be incorporated into the circuit to increase the timing capability.
- ii. A voice response could also be used for the alarm system in place of the buzzer.
- iii. A dual power supply (AC and DC) with automatic charging system can also be introduced to improve on its efficiency.

REFERENCES

- [1] Wikipedia the free encyclopedia www.en.wikipedia.org/wiki/timer
- [2] www.en.wikipedia.org/wiki/electromechanical_timers
- [3] www.en.wikipedia.org/wiki/electronic_timers
- [4] History of counting-www.historyworld.net/natures_abacus
- [5] History of counting and numbers-www.geocities.com
- [6] Egyptian numerals- <http://www.history.mcs.stand.ac.uk/His>
- [7] Babylonian number-www.timelineindex.com.uk/hist
- [8] The first millennium abacus- www.fullissue.com/history-of-counting-system-and-numeral
- [9] Roman numerals: from 3rd century- www.bookrags.com/research/binary-number-system-worm/
- [10] Binary number system- www.laits.utexas.edu
- [11] Photo modules for PCM Remote control system document Number 82030“<http://www.vishayd.com> pg 1-7
- [12] counter- http://www.Playhookey.com/digital/synchronic_counter.html
- [13] Decade counter- <http://www.encyclopedia.com/doc/1011-decadecounter.html>
- [14] <http://tams-www.informatik.uni-hamburg.de/updown.html>
- [15] www.worldlingo.com/ma/enwiki/en/Ring_counter
- [16] “Beam interruption” http://infra-red.com/basin_interruptions.Pdf pg 10-12
- [17] Black body radiation “<http://www.hypertetbook.com/Fact/infrared/radiation.htm>. Pg 17-21
- [18] www.en.wikipedia.org/wiki/mechanical_timers
- [19] www.en.wikipedia.org/wiki/computer_timers
- [20] Y.A. Adediran, Applied Electricity. Minna—Nigeria, 2000, pp. 99-108.
- [21] Diode from Wikipedia <http://en.wikipedia.org/wiki/Diode>
- [22] Basic Rectifier Circuits http://www.play-hookey.com/ac_theory/ps_rectifiers.html
- [23] Horowitz P, Hill W, The Art Of Electronics, 2nd Ed., Cambridge University Press, U.S.A., 1995.
- [24] National Semiconductor- www.national.com

- [25] Capacitor - Wikipedia, the free encyclopaedia www.en.wikipedia.org/wiki/capacitor
- [26] Keypad-From Wikipedia, the free encyclopedia www.en.wikipedia.org/wiki/keypad
- [27] Common keypads- <http://www.dialabc.com/>

APPENDIX

```
ORG 0000H
CLR A
MOV R0,#00H
MOV R1,#00H
MOV R2,#00H
MOV R3,#00H
MOV R4,#00H
MOV R5,#00H
MOV R6,#00H
MOV R7,#00H
DB0 EQU P3.0
DB1 EQU P3.1
DB2 EQU P3.2
DB3 EQU P3.3
DB4 EQU P3.4
DB5 EQU P3.5
DB6 EQU P3.6
DB7 EQU P3.7
DATA EQU P3
RS EQU P1.2
RW EQU P1.3
EN EQU P1.4
LJMP CT
VEENA:LCALL INITLCD
      LCALL CLR_LCD
      RET
INITLCD:CLR RS
      MOV DATA,#38H
      SETB EN
      CLR EN
      LCALL WAIT_LCD
      CLR RS
      MOV DATA,#0EH
      SETB EN
      CLR EN
      LCALL WAIT_LCD
      CLR RS
      MOV DATA,#06H
      SETB EN
      CLR EN
      LCALL WAIT_LCD
      RET
INIT_LCD:CLR RS
      MOV DATA,#38H
      SETB EN
      CLR EN
      LCALL WAIT_LCD
      CLR RS
```

```

MOV DATA,#0FH
SETB EN
CLR EN
LCALL WAIT_LCD
CLR RS
MOV DATA,#06H
SETB EN
CLR EN
LCALL WAIT_LCD
RET
WAIT_LCD: CLR EN
CLR RS
SETB RW
MOV DATA,#0FFH
SETB EN
MOV A, DATA
INC R3
CJNE R3,#255,RAYZOR
SJMP OZIL
RAYZOR: JB ACC.7,WAIT_LCD
CLR EN
CLR RW
OZIL: MOV R3,#00H
RET

WRITE_TEXT: SETB RS
MOV DATA,A
SETB EN
CLR EN
LCALL WAIT_LCD
RET
TAIMEOUT: LCALL VEENA
MOV A,#'T'
LCALL WRITE_TEXT
MOV A,#'I'
LCALL WRITE_TEXT
MOV A,#'M'
LCALL WRITE_TEXT
MOV A,#'E'
LCALL WRITE_TEXT
MOV A,#' '
LCALL WRITE_TEXT
MOV A,#'O'
LCALL WRITE_TEXT
MOV A,#'U'
LCALL WRITE_TEXT
MOV A,#'T'
LCALL WRITE_TEXT
RET

OJAY: LCALL OJ
INC R0

```



```

ONEOJ:JNB P0.0,$
      SJMP ONE
TWOJ:JNB P0.1,$
      SJMP TWO
THROJ:JNB P0.2,$
      SJMP THR
FOUJ:JNB P0.3,$
      SJMP FOU
FIVJ:JNB P0.4,$
      SJMP FIV
SIXJ:JNB P0.5,$
      SJMP SIX
SEVOJ:JNB P0.6,$
      SJMP SEV
EIGJ:JNB P0.7,$
      SJMP EIG
NINJ:JNB P2.7,$
      SJMP NIN
TENJ:JNB P2.6,$
      SJMP TEN
ONE:MOV A,#'1'
      MOV R6,#1
      SJMP ESS
TWO:MOV A,#'2'
      MOV R6,#2
      SJMP ESS
THR:MOV A,#'3'
      MOV R6,#3
      SJMP ESS
FOU:MOV A,#'4'
      MOV R6,#4
      SJMP ESS
FIV:MOV A,#'5'
      MOV R6,#5
      SJMP ESS
SIX:MOV A,#'6'
      MOV R6,#6
      SJMP ESS
SEV:MOV A,#'7'
      MOV R6,#7
      SJMP ESS
EIG:MOV A,#'8'
      MOV R6,#8
      SJMP ESS
NIN:MOV A,#'9'
      MOV R6,#9
      SJMP ESS
TEN:MOV A,#'0'
      MOV R6,#0
ESS:LCALL WRITE_TEXT
      LCALL OJ

```

```

RET
VEENITA:LCALL INIT_LCD
        LCALL CLR_LCD
        RET
HELLO:LCALL VEENA

INVAL:LCALL VEENA

NEXT_LINE:CLR RS
        MOV DATA,#0C0H
        SETB EN
        CLR EN
        LCALL WAIT_LCD
        RET
UMARU:CJNE A,#1,TOOO
        MOV A,#'1'
        SJMP DEAR
TOOO:CJNE A,#2,TERE
        MOV A,#'2'
        SJMP DEAR
TERE:CJNE A,#3,FOUUR
        MOV A,#'3'
        SJMP DEAR
FOUUR:CJNE A,#4,FAIVE
        MOV A,#'4'
        SJMP DEAR
FAIVE:CJNE A,#5,SEX
        MOV A,#'5'
        SJMP DEAR
SEX:CJNE A,#6,SAVEN
        MOV A,#'6'
        SJMP DEAR
SAVEN:CJNE A,#7,EITE
        MOV A,#'7'
        SJMP DEAR
EITE:CJNE A,#8,NAINE
        MOV A,#'8'
        SJMP DEAR
NAINE:CJNE A,#9,TAEN
        MOV A,#'9'
        SJMP DEAR
TAEN:MOV A,#'0'
DEAR:LCALL WRITE_TEXT
        RET
ENTPIN:LCALL VEENA
        MOV A,#'E'

TIMEE:LCALL VEENITA

IMPRESSE: CLR RS
        MOV DATA,#8EH

```

```

        SETB EN
        CLR EN
        LCALL WAIT_LCD
        RET
DONE: CLR RS
        MOV DATA, #81H
        LCALL KAMP
        RET
DTWO: CLR RS
        MOV DATA, #82H
        LCALL KAMP
        RET
DTHR: CLR RS
        MOV DATA, #83H
        LCALL KAMP
        RET
HONE: CLR RS
        MOV DATA, #85H
        LCALL KAMP
        RET
HTWO: CLR RS
        MOV DATA, #86H
        LCALL KAMP
        RET
MONE: CLR RS
        MOV DATA, #88H
        LCALL KAMP
        RET
MTWO: CLR RS
        MOV DATA, #89H
        LCALL KAMP
        RET
SONE: CLR RS
        MOV DATA, #8BH
        LCALL KAMP
        RET
STWO: CLR RS
        MOV DATA, #8CH
        LCALL KAMP
        RET
KAMP: SETB EN
        CLR EN
        LCALL WAIT_LCD
        RET
CT: LCALL OJAY

TIMEOUT: LCALL TAIMEOUT
        CLR P1.0
        LCALL OJAY
        LCALL OJAY
        LCALL OJAY

```