

**DESIGN AND CONSTRUCTION OF A
MICRO-CONTROLLER BASED
GREENHOUSE MONITORING AND
CONTROL SYSTEM**

TADI DANIEL VICTOR

2005/22100EE

DEPARTMENT OF ELECTRICAL AND COMPUTER
ENGINEERING, FEDERAL UNIVERSITY OF TECHNOLOGY,
MINNA, NIGER STATE, NIGERIA

NOVEMBER, 2010

**DESIGN AND CONSTRUCTION OF A
MICRO-CONTROLLER BASED
GREENHOUSE MONITORING AND
CONTROL SYSTEM**

TADI DANIEL VICTOR

2005/22100EE

A project submitted to the Department of Electrical and
Computer Engineering, Federal University of Technology,
Minna, Niger state, Nigeria.

NOVEMBER, 2010

DEDICATION

This project work is dedicated to the loving memory of my grandfather, Late Mr. Yila B. Tadi and my father, Late Mr. Victor Y. Tadi. May their souls rest in peace (Amen).

ABSTRACT

Agriculture is seen as an area which can be harnessed as the Nigerian economy is being diversified, but its being threatened by climate change. Appropriate environmental conditions - as obtained in a greenhouse- are necessary for optimum plant growth, improved crop yields, and efficient use of water and other resources. Automating the data acquisition process of the soil conditions and various climatic parameters that govern plant growth allows information to be collected at high frequency with less labour requirements.

A low power, cost efficient microcontroller chip is used to accomplish the automation of a greenhouse. It communicates with various sensors in real-time in order to control the light, aeration and drainage process efficiently inside a greenhouse by actuating a cooler, fogger, dripper and lights respectively according to the necessary condition of the greenhouse. An integrated Liquid crystal display (LCD) is also used for real time display of data acquired from the various sensors. Also, the use of easily available components reduces the manufacturing and maintenance costs. The design is quite flexible as the software can be changed any time and tailor-made to the specific requirements of the user.

This makes the proposed system an economical, portable, and a low maintenance solution for greenhouse applications, especially in rural areas and for small scale agriculturists.

TABLE OF CONTENTS

DEDICATION	iii
DECLARATION	iv
ACKNOWLEDGEMENT	v
ABSTRACT	vi
CHAPTER ONE: INTRODUCTION	1
1.1 INTRODUCTION	1
1.2 CURRENT SCENARIO OF GREENHOUSES IN NIGERIA	2
1.3 PROBLEM STATEMENT	2
1.4 METHODOLOGY	3
1.5 PROPOSED MODEL FOR AUTOMATION OF GREENHOUSE	5
CHAPTER TWO: THEORETICAL BACKGROUND	6
2.1 THEORETICAL BACKGROUND	6
2.2 GREENHOUSE	6
2.2.1 PLANT'S LIFE PROCESS WITHIN A GREENHOUSE	7
2.3 BASIC MODEL OF THE SYSTEM	10
2.3.1 POWER SUPPLY UNIT	11
2.3.2 TRANSDUCERS (DATA ACQUISITION SYSTEM)	15
2.3.3 MULTIPLEXER	15
2.3.4 ANALOG -TO-DIGITAL CONVERTER (ADC)	15
2.3.5 MICROCONTROLLER	16
2.3.6 ACTUATOR	19
2.3.7 DISPLAY UNIT	21
CHAPTER THREE: DESIGN AND CONSTRUCTION	23
3.1 THE POWER SUPPLY UNIT	23
3.2 DATA ACQUISITION SYSTEM (TRANSDUCERS)	25
3.3 MULTIPLEXING UNIT (MU)	30
3.4 ANALOG TO DIGITAL CONVERTER (ADC)	31
3.5 MICROCONTROLLER (AT89C52)	32
3.6 ACTUATOR UNIT (AU)	36
3.7 DISPLAY UNIT (DU)	37
CHAPTER FOUR: TEST, RESULT AND DISCUSSION	39
4.1 CONSTRUCTION	39
4.2 TESTING AND RESULT	39
4.3 PROBLEM ENCOUNTERED	42
4.4 LIST OF COMPONENTS	43

CHAPTER FIVE: CONCLUSION	44
5.1 SUMMARY	44
5.2 CONCLUSION	44
5.3 RECOMMENDATION	44
REFERENCES	46
APPENDIX	47

LIST OF FIGURES

- Fig. 2.1 Transpiration
- Fig. 2.2 Block diagram of the system
- Fig. 2.3 Block diagram of a power supply unit
- Fig. 2.4 Transformer (Single Phase)
- Fig. 2.5 Full Wave Bridge Circuit
- Fig. 2.6 DC filtering process
- Fig. 2.7 General block diagram of a typical ADC
- Fig. 2.8 AT89C52 (Micro-Controller)
- Fig. 2.9 Sugar cube relay
- Fig 2.10 Pin diagram of 2x16 LCD
- Fig. 3.1 Power Supply Unit
- Fig. 3.2 Soil moisture sensor
- Fig. 3.3 Light Dependent Resistor
- Fig. 3.4 Structure of a LDR, showing CdS track and an atom to illustrate electrons in the valence and conduction bands
- Fig. 3.5 Light sensor
- Fig 3.6 Humidity sensor circuit
- Fig. 3.7 LM35 temperature sensor and Temperature sensor circuit
- Fig. 3.8 Truth table for channel selection and pin description of CD4052BC
- Fig. 3.9 The Multiplexing unit
- Fig. 3.10 ADC Unit
- Fig. 3.11 Microcontroller Unit Circuit
- Fig. 3.12 Actuating Unit
- Fig. 3.13 Display Unit
- Fig 3.14 Complete circuit diagram

LIST OF TABLES

Table 1.1	Importance of the various parameters
Table 4.1	Soil moisture sensor readings
Table 4.2	Light sensor readings
Table 4.3	Humidity sensor readings
Table 4.4	Temperature sensor readings

CHAPTER ONE

1.1 Introduction

The quest for Nigeria to be one of the twenty leading economies in the world by the year 2020 with agriculture playing a vital role is being threatened by the warming of the earth's surface and troposphere (the lowest layer of the atmosphere). This is caused by the presence of water vapour, carbon dioxide, methane and certain other gases in the air through a process known as greenhouse effect [1].

This global warming could alter the plant's microclimate - description of the atmospheric conditions immediately surrounding a plant or crop which is affected by localised variations in many factors [2] - and thereby produce new patterns and extremes of drought and rainfall and possibly disrupt food production in certain regions [1]. Most agricultural contribution to greenhouse effect is from developing countries such as Nigeria [3].

Greenhouses also called glasshouses, form an important part of the agriculture and horticulture sectors in Nigeria, as they can be used to grow plants under controlled climatic conditions for optimum yield and quality, and also enables plant material to be supplied outside its normal availability, e.g. tomatoes to a high specification over an extended season, and cucumbers from an area where the climate is not otherwise suitable. Since practically, a microclimate in protected cultivation can be manipulated [2], automating a greenhouse envisages monitoring and controlling of the temperature, soil moisture, humidity and sunlight, which directly or indirectly govern the plant growth and hence, their produce. Automation is process control of industrial machinery and processes, thereby replacing human operators.

1.2 Current Scenario of Greenhouses in Nigeria

Greenhouses in Nigeria are mostly being deployed in the research centres located at the dissected plateau region of the country (land marked with numerous hills and valleys containing a great number of streams and rivers) as the case of the International Institute for Tropical Agriculture (IITA) Ibadan, Nigeria. There are three (3) common methods of setting up a greenhouse, viz;

I. Manual Set-Up:

This set-up involves visual inspection of the plant growth, manual irrigation of plants, turning ON and OFF the temperature controllers, manual spraying of the fertilizers and pesticides. It is time consuming, vulnerable to human error and hence less accurate and unreliable.

II. Partially Automated Set-Up:

This set-up is a combination of manual supervision and partial automation and is similar to manual set-up in most respects but it reduces the labour involved in maintaining the set-up.

III. Fully- Automated:

This is a sophisticated set-up which is well equipped to react to most of the climatic changes occurring inside the greenhouse. It works on a feedback system which helps it to respond to the external stimuli efficiently. Although this set-up overcomes the problems caused due to human errors it is usually very expensive.

1.3 Problem Statement

A number of problems associated with the above mentioned systems are enumerated as below:

1. Complexity involved in monitoring climatic parameters like humidity, soil moisture, illumination, soil pH, temperature, etc which directly or indirectly govern the plant growth.

2. Investment in the automation process is high (about ₦54,000 per m² [13]), as today's greenhouse control systems are designed for only one parameter monitoring; to control more than one parameter simultaneously there will be a need to buy more than one system.
3. High maintenance and need for skilled technical labour. Moreover farmers in Nigeria do not work under such sophisticated environment and find no necessity of such an advanced system, and cannot afford the same.
4. They are usually located far away from the owner's house, and the plant growth in a greenhouse is an example of the process which needs continuous monitoring.

Keeping these issues in view, a microcontroller based monitoring and control system is designed to find implementation in the near future that will help Nigerian farmers.

1.4 Methodology:

The steps taken in designing the system are:

1. Identify measurable variables important to plant growth.

It is very important to correctly identify the parameters that are going to be measured by the controller's data acquisition interface, and how they are to be measured. The set of variables typically used in greenhouse control is as shown in Table 1.1:

Table 1.1 Importance of the various parameters

S/N	Variable to be monitored	Its Importance
1	Temperature	Affects all plant metabolic functions.
2	Humidity	Affects transpiration rate and the plant's thermal control mechanisms.
3	Soil moisture	Affects salinity, and pH of irrigation water
4	Solar Radiation	Affects photosynthetic rate, responsible for most thermal load during warm periods

An electronic sensor for measuring a variable must be readily available, accurate, reliable and low in cost. Some times the variables that cannot be directly or continuously measured can be controlled in a limited way by the system. For example, fertility levels in nutrient solutions for greenhouse production are difficult to measure continuously.

II. Investigate the control strategies.

An important element to be considered in a control system is the control strategy that is to be followed. The simplest strategy- which I used- was to use threshold sensors that directly affect actuation of devices. For example, the temperature inside a greenhouse can be affected by controlling heaters, fans, or window openings once it exceeds the maximum allowable limit. The light intensity is controlled using four threshold levels. As the light intensity decreases one light is turned on. With a further decrease in its intensity a second light would be powered, and so on; thus ensuring that the plants are not deprived of adequate sunlight even during the raining season or a cloudy day and have a longer photoperiod.

III. Identify the software and the hardware to be used.

It is very important that control system functions are specified before deciding what software and hardware system to purchase. The model chosen must have the ability to:

1. Expand the number of measured variables (input subsystem) and controlled devices (output subsystem) so that growth and changing needs of the production operation can be satisfied in the future.
2. Provide a flexible and easy to use interface.
3. It must ensure high precision measurement and must have the ability to resist noise.

Hardware must always follow the selection of software, with the hardware required being supported by the software selected. In addition to functional capabilities, the selection of the control hardware included factors such as reliability, support, previous experiences with the equipment (successes and failures), and cost.

1.4 Proposed Model for Automation of Greenhouse

The proposed system is an embedded system which will closely monitor and control the microclimatic parameters of a greenhouse on a regular basis, for cultivation of crops or specific plant species which could maximize their production over the whole crop growth season and to eliminate the difficulties involved in the system by reducing human intervention. The system comprises of Sensors, a Multiplexer, Analogue-Digital Converter, Microcontroller, and Actuators.

When any of the above mentioned climatic parameters in Table 1.1 crosses a safety threshold which has to be maintained to protect the crops, the sensors sense the change and the microcontroller reads this from the data at its input ports after being converted to a digital form by the ADC. The microcontroller then performs the needed actions by employing relays until the strayed-out parameter has been brought back to its optimum level. Since a microcontroller is used as the heart of the system, it makes the set-up low-cost and effective. As the system also employs an LCD display for continuously alerting the user about the condition within the greenhouse, the entire set-up becomes user friendly.

Thus, this system is designed as an easy to maintain, flexible and low cost solution.

CHAPTER TWO

In this chapter, a theoretical and historical background of greenhouses with the various electrical components used to achieve the monitoring and control system will be discussed. This will include a proper definition and history of the greenhouse, the different types, and life process of plants within the greenhouse will also be discussed. The various units that make up the complete system and their principles of operation as it relates to the greenhouse monitoring and control will be discussed in this chapter.

2.1 Theoretical Background

Plants, like other living organisms, have certain requirements for growth. Climatic conditions are not uniform throughout the world. As such certain plants are grown or found in nature only in certain regions (i.e. plants are adapted to certain environments). For these plants to be grown out of season, plants must be grown in a controlled environment, meaning that humans, not nature, determine how the conditions change. One such environment is the greenhouse [4].

2.2 Greenhouse

A greenhouse is a specially constructed building for growing plants under controlled conditions. The building has no green colour but perhaps gets its name from the fact that (green) plants are grown in it [4]. In the 17th century, greenhouses were ordinary brick or timber shelters with a normal proportion of window space and some means of heating. As glass became cheaper and as more sophisticated forms of heating became available, the greenhouse evolved into a roofed and walled structure built of glass with a minimal wooden or metal skeleton. By the middle of the 19th century, the greenhouse had developed from a mere refuge from a hostile climate into a controlled environment, adapted to the needs of particular plants [9]. They differ in size, design, and the extent of environmental control [4].

Small domestic greenhouses are frequently lean-to structures built against an existing wall. They consist of a glass-paned sloping roof and three supporting glass-paned sides. Large, conventional commercial greenhouses have A-shaped roofs over two sidewalls and two end walls. Another extensively used commercial greenhouse is the ridge-and-furrow house, which consists of several units placed side by side with no partitioning between them. A third and low-cost greenhouse consists of a Quonset-shaped frame with one or two layers of plastic film stretched over it; the double layer can save up to 40 percent in heating fuel [5]. Some of the simplest ones are capable of naturally controlling temperature and light. Others are fitted with state-of-the-art computer-based equipment for controlling humidity, light, temperature, nutrients, and soil moisture but are mostly very expensive [4].

Greenhouses are normally called GLASSHOUSES in Europe [4].

2.2.1 Plant's Life Process within a Greenhouse:

Plant growth processes provide the raw materials and the energy required for building new tissues and nurturing them to maturity. Major process involves photosynthesis and transpiration.

A. Photosynthetic Process

Photosynthesis is a reaction occurring in green plants whereby plants utilize water and energy of sunlight to fix inorganic carbon dioxide in the form of organic compounds (carbohydrates), releasing oxygen in the process. If anyone of these factors is in short supply, then the process will be slowed down or even stopped. This principle is called the law of limiting factors, which states that the factor in least supply will limit the rate of the process, and applies to other non photosynthetic processes in the plant [4]. Photosynthesis is arguably the most important biochemical pathway, since nearly all life on earth either directly or indirectly depends on it.

A commonly used but slightly simplified equation for photosynthesis is:

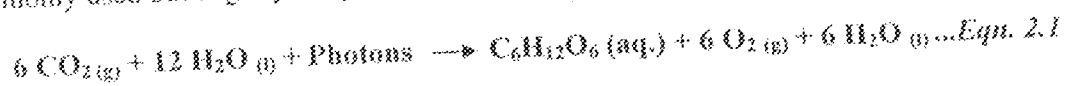

Carbon dioxide + water + light energy \longrightarrow glucose + oxygen + water

Environmental Factors Affecting Photosynthesis

The rate of photosynthesis is affected by a number of factors, including light intensity, CO_2 concentration, temperature, water availability, photo period.

i. Light Intensity:

Light is important for the production of enzymes which serves as catalyst during the photosynthetic process. Thus, at low light intensities, these products are not produced in adequate amounts. However, when light intensity is extreme, other factors may be limited causing the rate of photosynthesis to decline. Plants need an optimum amount of exposure to light in a day. This optimum period is called its photo-period. Sunlight has a continual spectrum, radiating energy in wavelengths that contribute less to photosynthesis, and are therefore "wasted" on the plant. For this reason, gas discharge lamps or/and low pressure mercury filled tubes suitably grouped in banks, provide more efficient light than sunlight for plants [7].

Plants need dark periods. Periods of light (called photo-periods) and dark periods and their relative lengths have an effect on plant maturity. The dark period of each day affects flowering and seeding of most plants. Although many plants can grow under continuous light, nearly all plants prefer a dark period each day for normal growth. Maximum amount of light many plants can usefully absorb is approximately 30,000 Lux, while good growth in many plants will occur at 10,000-15,000 Lux [4].

ii. Temperature:

Photosynthetic rate decreases at cold temperature, because, the fixation stage is temperature sensitive. However under conditions in which light is a limiting factor (low light

conditions) the effect of temperature on photosynthesis is minimal. Enzyme activity also increases with temperature from 0°C to 36°C, and ceases at 40°C. 25°C to 36°C are usually optimum temperatures for plants [6]. The greenhouse works best when the temperature is not too hot and not too cold.

iii. Water Availability:

Water is a vital element for plant life. Most plants consist for 85 to 98% of water. Water is needed to build some molecules, water fills plants cells water acts as a transport medium, provides cell turgor (firmness) and cools the plant [12]. When plants grow under conditions of moisture stress because of low soil moisture or dry winds (low humidity) that accelerate transpiration, enzymatic activities associated with photosynthesis in the plants slow down. The stoma closes under moisture stress, reducing carbon dioxide availability and consequently decreasing photosynthetic rate. The moisture content in the soil is a very crucial factor in the process of transpiration as the absorption of mineral salts from the soil through the process of osmosis is directly dependent on the moisture content in the soil [2].

iv. Humidity:

Air humidity affects the plant processes like transpiration, water uptake, nutrient transport, cell turgor and growth. High humidity restricts transpiration, because very humid air is almost saturated with water vapour and cannot absorb much more. At times of reduced transpiration, the water uptake is low, and therefore transport of nutrients from roots to shoots is restricted. This could lead to deficiency if the condition last for a longer period of time (e.g. a week). Low humidity stimulates transpiration, which is good. But at very low humidity the leaves loose so much water that the xylem flow cannot completely replace the water losses, and thus plants cannot maintain turgor in the plant cells. Therefore, a low humidity for a long period of time generally results in the shorter plants and smaller leaf area. Though, these conditions depend also on the crop been grown [12]. Other things being equal, the transpiration rate decreases with increasing humidity; thus, rate of water use is higher at low

levels of humidity. The benefits of irrigation are apparently greater when the humidity is high, which simply means that the efficiency of water use increases with humidity [10].

B. Transpiration

Transpiration is the evaporation of water from the aerial parts of plant, especially leaves but also stems, flowers, and roots. Transpiration also cools plants and enables mass flow of mineral nutrients and water from roots to shoots.

The rate of transpiration is directly related to the degree of stomata opening, to the evaporative demand of the atmosphere surrounding the leaf and is doubled with a more than 10°C (50°F) rise in temperature. Transpiration is slower in environments of high humidity. The amount of water lost by a plant depends on its size, along with the surrounding light intensity, temperature, humidity, and wind speed (all of which influence evaporative demand). Soil water supply and soil temperature can influence stomata opening, and thus the transpiration rate.

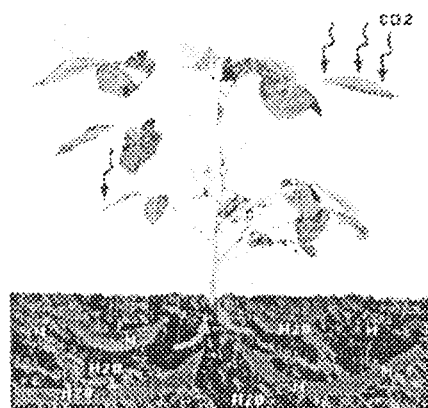

Fig 2.1 Transpiration

2.3 Basic Model of the System

Today, advances in sensors, actuators and microprocessor technology, both on hardware and software level, have enabled distributed implementation of sensor and control actions over sensor/actuators networks [19]. The system comprised of a Power Supply Unit, Sensor Unit (temperature, humidity, light, and soil moisture sensors), Multiplexer (CD4052), Analogue-Digital Converter (ADC 0804), Microcontroller (AT89S52), Liquid Crystal

Display (Hitachi's HD44780), Actuator (Relay), and Devices controlled - Water Pump (simulated with LED), Sprayer (simulated with LED), Cooler (simulated as a Fan), and Artificial Lights (simulated with two LEDs).

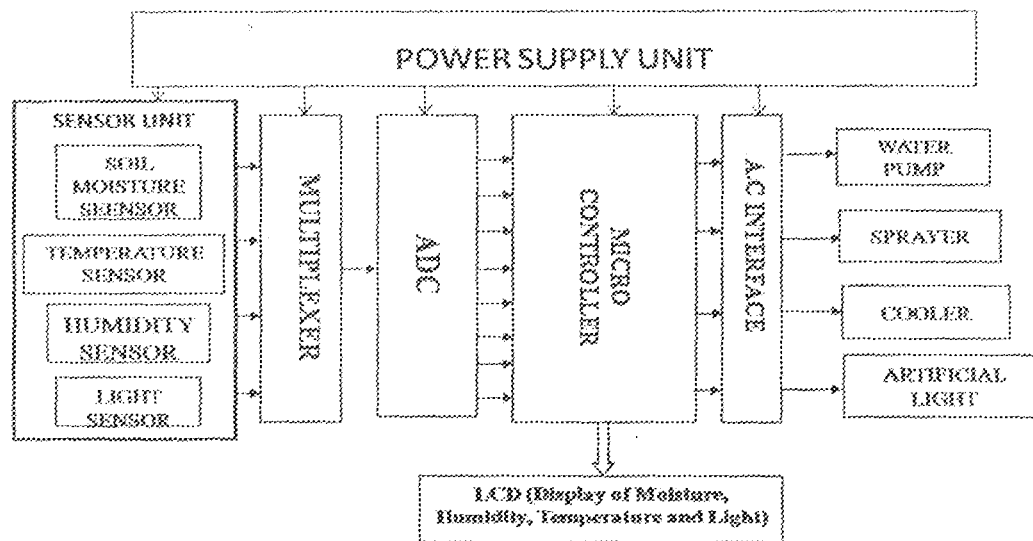

Fig. 2.2 Block diagram of the system

2.3.1 Power Supply Unit

The power supply unit consist of the following components illustrated in a sub-block diagram in Fig. 2.3 below:

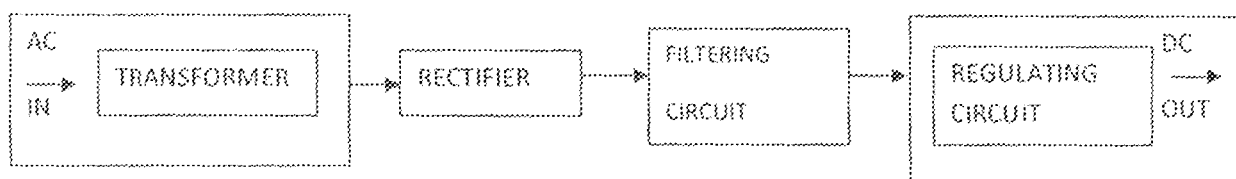

Fig. 2.3 Block diagram of a power supply unit

Transformer

The transformer is a static piece of apparatus by means of which electrical power in one circuit is transformed into electrical power of the same frequency in another circuit. It raises or lowers the voltage in a circuit, also with a corresponding decrease or increase in current. The rating of the transformer includes only r.m.s secondary voltage at the maximum rated secondary current with the specified line voltage at the primary. The capacity of a transformer is measured in VA (volt ampere); it depends on the size and material of the core.

The core is laminated to minimize losses due to current in the core known as eddy currents loss. [11]

It also provides electrical ground insulation for devices from the power line to reduce potential shock hazards.

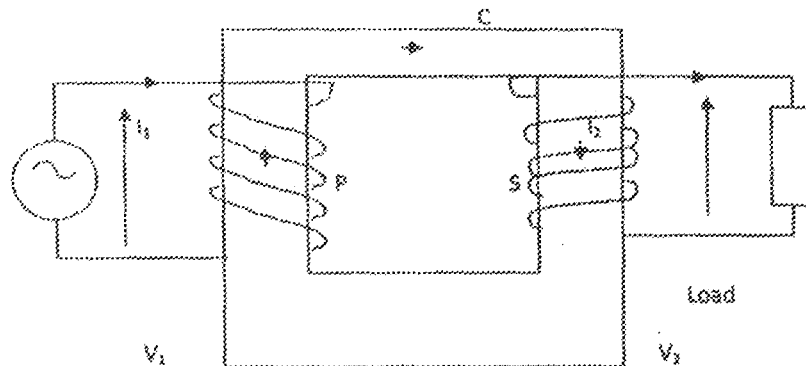

Fig. 2.4 Transformer (Single Phase)

Rectification

It is a circuit that employs one or more diode to convert AC into DC. Rectification is classified into:

1. Half wave rectification
2. Full wave rectification
3. Bridge rectification

However, only the Bridge rectification will be discussed as it is the type of rectification employed in this project.

Bridge Rectification

The full wave bridge rectifier is the most commonly used circuit for power supplies, it requires four diodes but the transformer is not centre tapped. The rectifier provides pulsating DC voltage output. During the positive input half cycle, D1 and D3 becomes forward biased (ON) whereas D2 and D4 are reversed biased (OFF), current flows during the negative input half cycle, D2 and D4 becomes forward biased, circuit current flows. Current

keep flowing through the load in the same direction during both half cycles of the AC input supply. [11]

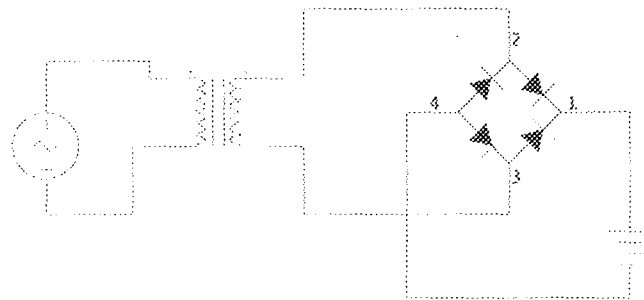
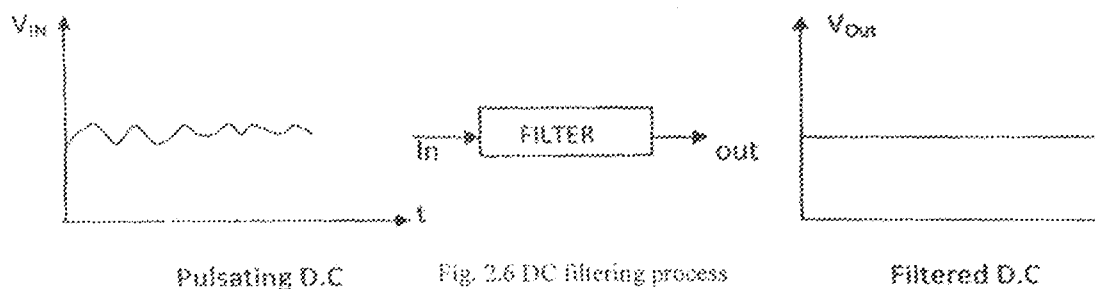

Figure 2.5 Full Wave Bridge Circuit.

Ripple Filtering

By the analysis of Fourier series, we know that a rectified sine wave consists of a D.C components and harmonics of the supply frequency. These harmonics are responsible for the ripples and this is undesirable for smooth operation of electronics circuits. The process of removing these ripples is known as filtering. A ripple filter is basically a low pass filter that passes the D.C components and attenuates the A.C components. The five main types of filter circuit are:

1. Resistance capacitance (RC) filter
2. Capacitor input filter.
3. Inductance of choke capacitor (LC) filter
4. R – L – C filter
5. Series induction filter



The filtering process used in the system is the capacitor input filter circuit, used for filtering the rectified A.C supply from the transformer. The action of this system depends on

the fact that the capacitor stores energy during the conduction period and delivers this energy to the load during the non-conductive period. In this way, the time during which the current passes through the load is prolonged and the ripple is considered decreased. Ripples are the A.C components of a supposed D.C output from the rectifier. The ripple voltage, V_r , is given by the equation [11]:

$$V_r = \frac{2.4 \times V_{dc}}{C \times R1} \dots \dots \dots Eqn 2.2$$

IC Regulators

When a power supply is designed to produce a definite voltage output, it is desirable that the output voltage remained relatively constant when the load is applied to the supply. Due to low-cost fabrication technique, many commercial integrated circuit (IC) regulation are available since the past two decades. These include fairly simple, fixed-voltage types of high quality precision regulators. They have much improved performance as compared to limiting self protection against over temperature, remote control operation over a wide range of input voltages and foldback current limiting.

They include:

1. Fixed positive linear voltage regulators
2. Fixed negative linear voltage regulators
3. Adjustable positive linear voltage regulators
4. Adjustable negative linear voltage regulators

The 7800 series ICs are Fixed positive linear voltage regulators with three terminals which are available in varying degree of complexity. The last two digits in the part number designate the output voltage. Percentage of regulation is given by the equation 2.3 given below:

$$\% \text{regulation} = \frac{V_{max} - V_{min}}{V_{max}} \times 100 \dots \dots \dots Eqn 2.3$$

Where V_{max} = Maximum DC output and V_{min} = Minimum DC output

2.3.2 Transducers (Data Acquisition System):

A transducer is a device that converts one quantity into another quantity, specifically when one of the quantities is electrical. Thus, a photocell converts light into electricity; a thermocouple converts heat into electricity, etc [19]. This part of the system consists of various transducers, namely soil moisture sensor, humidity sensor, temperature sensor, and light/dark sensor. These sensors sense various parameters- temperature, humidity, soil moisture, and light intensity- and send the various sensor data to the Multiplexer.

2.3.3 Multiplexer

A multiplexer or data selector selects one of several input signals and passes it on to its output. This routing of the desired data input to the output is controlled by SELECT INPUTS (often referred to as ADDRESS INPUTS). It acts as a digitally controlled multi-positional switch where the digital code applied to the select input inputs controls which data inputs will be switched to the output. They are used for data routing, parallel to serial conversion, operation sequencing and logic function generation [14]. One such multiplexer is the CD4052. The multiplexer selects one of the four signals outputted by the various sensors and passes it on to the Analog-to-Digital Converter.

2.3.4 Analog -To-Digital Converter (ADC):

An analog to digital converter takes an analog input voltage and after a certain amount of time produces a digital output code that that represents the analog input. Many types of ADCs exist, but the Digital-Ramp A/D is the simplest to understand but not often used due to variable conversion time. A successive approximation converter has a constant conversion time and is probably the most common general-purpose converter. An example of a successive approximation A/D converter is the ADC0804 used in this project.

The ADC0804 has two analog inputs, $V_{IN (+)}$ and $V_{IN (-)}$, to allow differential input ($V_{IN} = V_{IN (+)} - V_{IN (-)}$). It also converts the analog input voltage to an 8 bit digital output with a resolution of 19.6mV. Its internal clock generator circuit produces a frequency of;

$$f = 1/1.1RC \dots \dots \dots \text{Eqn 2.4}$$

Where R and C are values of the externally connected resistor and capacitor that will give a minimum of 606-kHz of clock frequency (conversion time = 1/f). For an N-bit SAC with N clock cycles, total conversion time is given by;

$$t_c \text{ for SAC} = N \times 1 \text{ clock cycle}$$

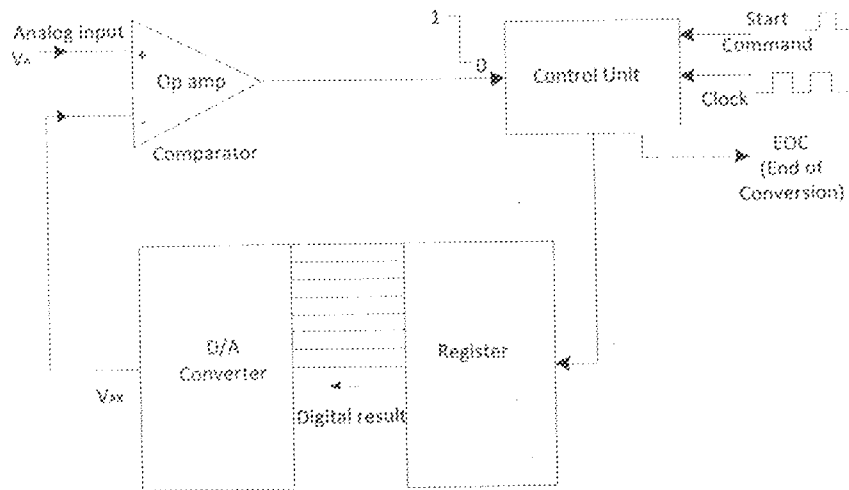

Fig. 2.7 General block diagram of a typical ADC

The selected analogue parameters measured by the sensors are then converted to corresponding digital values by the ADC.

2.3.5 Microcontroller

A microcontroller is a special-purpose microcomputer system; they have become an essential part of many engineering products, processes and systems, and are often deeply embedded in the inner-workings of many products and systems we use daily (for example, in automobile control systems, and in many consumer products and appliances, such as autofocus cameras and washing machines)[17].

The chip is programmed by the user for the purpose of controlling some devices. AT89C52 is an example of a micro-controller chip. The AT89C52 is a low-power, high-performance CMOS 8-bit microcomputer with 8Kbytes of Flash programmable and erasable read only memory (PEROM). The device is manufactured using Atmel's high-density non-

volatile memory technology and is compatible with the industry-standard 80C51 and 80C52 instruction set and pin-out. The on-chip Flash allows the program memory to be reprogrammed in-system or by a conventional non-volatile memory programmer. By combining a versatile 8-bit CPU with Flash on a monolithic chip, the Atmel AT89C52 is a powerful microcomputer which provides a highly-flexible and cost-effective solution to many embedded control applications.

The physical features of AT89C52 is shown in Fig. 2.8

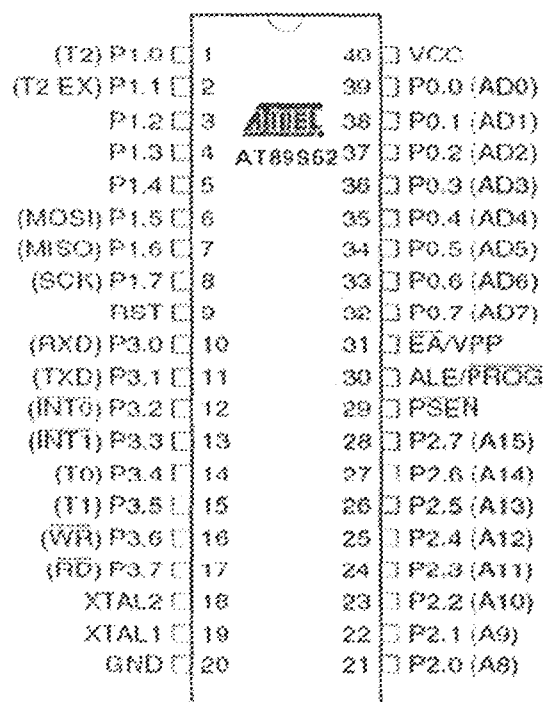

Fig. 2.8 AT89C52 (Micro-Controller)

Pin Configuration

- **VCC:** Supply voltage.
- **GND:** Ground.
- **Port 0:** Port 0 is an 8-bit open drain bidirectional I/O port. As an output port, each pin can sink eight TTL inputs. When 1s are written to port 0 pins, the pins can be used as

high-impedance inputs. Port 0 can also be configured to be the multiplexed low-order address/data bus during accesses to external program and data memory.

- **Port 1:** Port 1 is an 8-bit bidirectional I/O port with internal pull-ups. The Port 1 output buffers can sink/source four TTL inputs. When 1s are written to Port 1 pins, they are pulled high by the internal pull-ups and can be used as inputs. As inputs, Port 1 pins that are externally being pulled low will source current (IIL) because of the internal pull-ups. In addition, P1.0 and P1.1 can be configured to be the timer/counter 2 external count input (P1.0/T2) and the timer/counter 2 trigger input (P1.1/T2EX), respectively.
- **Port 2:** Port 2 is an 8-bit bidirectional I/O port with internal pull-ups. The Port 2 output buffers can sink/source four TTL inputs. When 1s are written to Port 2 pins, they are pulled high by the internal pull-ups and can be used as inputs. As inputs, Port 2 pins that are externally being pulled low will source current (IIL) because of the internal pull-ups. Port 2 emits the high-order address byte during fetches from external program memory and during accesses to external data memory that uses 16-bit addresses (MOVX @ DPTR). Port 2 emits the contents of the P2 Special Function register.
- **Port 3:** Port 3 is an 8-bit bidirectional I/O port with internal pull-ups. The Port 3 output buffers can sink/source four TTL inputs. When 1s are written to Port 3 pins, they are pulled high by the internal pull-ups and can be used as inputs. Port 3 receives some control signals for Flash programming and verification. Port 3 also serves the functions of various special features of the AT89C52 such as serial input/output, external interrupt, external timer input, and external data memory read/write.
- **RST:** Reset input. A high on this pin for two machine cycles while the oscillator is running resets the device.

- **ALE/PROG:** Address Latch Enable (ALE) is an output pulse for latching the low byte of the address during accesses to external memory. This pin is also the program pulse input (PROG) during Flash programming. If desired, ALE operation can be disabled by setting bit 0 of SFR location 8EH. Otherwise, the pin is weakly pulled high. Setting the ALE-disable bit has no effect if the microcontroller is in external execution mode.
- **PSEN:** Program Store Enable (PSEN) is the read strobe to external program memory. When the AT89S52 is executing code from external program memory, PSEN is activated twice each machine cycle, except that two PSEN activations are skipped during each access to external data memory.
- **EA:** External Access Enable (EA) must be strapped to GND in order to enable the device to fetch code from external program memory locations starting at 0000H up to FFFFH. However, if lock bit 1 is programmed, EA will be internally latched on reset. EA should be strapped to VCC for internal program executions. This pin also receives the 12-volt programming enable voltage (VPP) during Flash programming.
- **XTAL1:** Input to the inverting oscillator amplifier and input to the internal clock operating circuit.
- **XTAL2:** Output from the inverting oscillator amplifier. [16]

2.3.6 Actuator:

An actuator used in the system is the relay. They are used to turn on AC devices such as motors, coolers, pumps, fogging machines, sprayers.

A relay is an electrical switch that opens and closes under the control of another electrical circuit. In the original form, the switch is operated by an electromagnet to open or close one or many sets of contacts. It was invented by Joseph Henry in 1835. Because a relay is able to control an output circuit of higher power than the input circuit, it can be considered to be, in a broad sense, a form of an electrical amplifier.

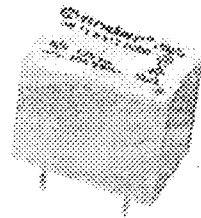

Fig. 2.9 Sugar cube relay

Despite the speed of technological developments, some products prove so popular that their key parameters and design features remain virtually unchanged for years. One such product is the 'sugar cube' relay, shown in the figure above, which has proved useful to many designers who needed to switch up to 10A, whilst using relatively little PCB area. Since relays are switches, the terminology applied to switches is also applied to relays. A relay will switch one or more poles, each of whose contacts can be thrown by energizing the coil in one of three ways:

- 1 **Normally - open (NO)** contacts connect the circuit when the relay is activated; the circuit is disconnected when the relay is inactive. It is also called a FORM A contact or "make" contact.
- 2 **Normally - closed (NC)** contacts disconnect the circuit when the relay is activated; the circuit is connected when relay is inactive. It is also called FORM B contact or "break" contact
- 3 **Change-over or double-throw** contacts control two circuits; one normally open contact and one normally -closed contact with a common terminal. It is also called a Form C "transfer" contact. [11]

For the purpose of demonstration, LEDs and a relay have been used to simulate actuators and to drive a fan. A complete working system can be realized by simply replacing these simulation devices by the actual devices.

2.3.7 Display Unit:

A Liquid crystal display is used to indicate the present status of parameters. It is a thin, flat display device made up of any number of colour or monochrome pixels arrayed in front of a light source or reflector. Each pixel consists of a column of liquid crystal molecules suspended between two transparent electrodes, and two polarizing filters, the axes of polarity of which are perpendicular to each other. The liquid crystal twists the polarization of light entering one filter to allow it to pass through the other [14]. The information is displayed in two modes –present parameters status and device status. Any display can be interfaced to the system with respective changes in driver circuitry and code. A typical LCD is the Hitachi's HD44780 module which is inexpensive and easy to use. The LCD also requires 3 control lines from the microcontroller:

- 1 **Enable (E):** This line allows access to the display through R/W and RS lines. When this line is low, the LCD is disabled and ignores signals from R/W and RS. When (E) line is high, the LCD checks the state of the two control lines and responds accordingly.
- 2 **Read/Write (R/W):** This line determines the direction of data between the LCD and microcontroller. When it is low, data is written to the LCD. When it is high, data is read from the LCD.
- 3 **Register Select (RS):** With the help of this line, the LCD interprets the type of data on data lines. When it is low, an instruction is being written to the LCD. When it is high, a character is being written to the LCD.

Pin Description

Most LCDs with 1 controller has 14 Pins and LCDs with 2 controller has 16 Pins (two pins are extra in both for back-light LED connections) [15].

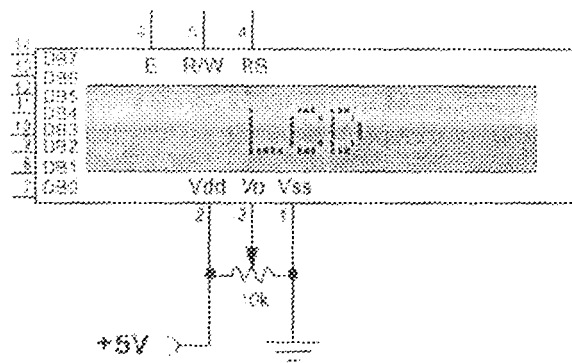

Fig 2.10 Pin diagram of 2x16 line LCD

Table 2.1 Pin description of the LCD

Pin No.	Name	Description
Pin no. 1	VSS	Power supply (GND)
Pin no. 2	VCC	Power supply (+5V)
Pin no. 3	VEE	Contrast adjust
Pin no. 4	RS	0 = Instruction input 1 = Data input
Pin no. 5	R/W	0 = Write to LCD module 1 = Read from LCD module
Pin no. 6	EN	Enable signal
Pin no. 7	D0	Data bus line 0 (LSB)
Pin no. 8	D1	Data bus line 1
Pin no. 9	D2	Data bus line 2
Pin no. 10	D3	Data bus line 3
Pin no. 11	D4	Data bus line 4
Pin no. 12	D5	Data bus line 5
Pin no. 13	D6	Data bus line 6
Pin no. 14	D7	Data bus line 7 (MSB)

2.3.8 Passive Components

Components such as the passive type are those components that cannot amplify power and require an external power source to operate. They are widely used in building electronics gadget. These components includes: resistors, capacitors, inductors, and transformers etc. Their application range from potential dividers to control of current (as in resistors), filtration of ripples voltages and blocking of unwanted D.C voltages (as in capacitor).They form the elements of the network circuit oscillator stages and are also used generally for signal conditioning in circuits. [8]

CHAPTER THREE

DESIGN AND IMPLEMENTATION

This chapter contains the steps taken in the design and implementation of the greenhouse monitoring and control system, a detailed explanation of each module that make up the whole system with well laid out circuit diagram of these modules, and justification of component selection. The modules are:

- Power Supply (PS)
- Data Acquisition System (DAS)
- Multiplexing Unit (MU)
- Analog to Digital Converter (ADC)
- Microcontroller (AT89C52)
- Actuator Unit (AC)
- Display Unit (DU)

3.1 The Power Supply Unit

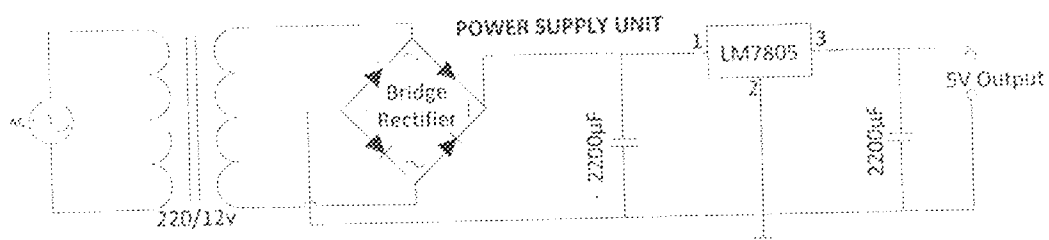

Fig. 3.1 Power Supply Unit

The source of supply to the circuit is from the mains supply. The power unit supply DC needed for the circuit operation. The voltage level was rectified and regulated to 5V using a 7805 voltage IC regulator.

Transformer rating of 220/12VAC, 500mA was chosen. For a voltage of 12volts, from transformer,

$$V_{\text{peak}} = 12 \times \sqrt{2} \text{ (i.e. rms } \times \sqrt{2}) \dots \dots \dots \text{ Eqn 3.1}$$

$$V_{\text{peak}} = 16.971\text{V}$$

At the rectifier stage, four (4) IN4001 diodes are used in a bridge configuration to rectify the transformer output to give;

$$V_{\text{max}} = 1.414 \times V_{\text{rms}} = 1.414 \times 12 = 16.971\text{V}$$

Hence the peak inverse voltage is equal to $V_{\text{max}} = 16.971\text{V}$.

The filter capacitor is chosen large enough to provide acceptably low ripple voltage, with voltage rating sufficient to handle the worst case combination of no load and high line voltage. For good design practice, electrolytic capacitors are used [8].

Having a 12 volt rms secondary transformer which delivers 16 volts (at peak of ripple) at full load-current and with a typical regulator dropout voltage of 2 volts, the input to the regulator should never dip below +7 volts. Contending with $\pm 10\%$ worst-case line-voltage variation and keeping ripple to less than 2 volts p-p.

$$Z = T \left(\frac{dV}{dT} \right) = \frac{TI}{C} = \frac{0.008 \times 0.5}{C} \dots \dots \dots \text{ Eqn 3.2}$$

$$2C = 0.004 \text{ i.e. } C = 2000\mu\text{F}$$

Therefore, a 2200 $\mu\text{F}/25\text{V}$ electrolytic capacitor is used. This also reduces transformer heating (by reducing conduction angle), acts as a buffer capacitor, and decreases stress on the rectifier. To increase transient response and keep the impedance low at high frequency, a 2200 $\mu\text{F}/25\text{V}$ electrolytic capacitor is connected after the 7805 regulator.

3.2 Data Acquisition System (Transducers):

Monitoring and controlling of a greenhouse environment involves sensing the changes occurring inside it which can influence the rate of growth in plants. The parameters which are of importance inside the greenhouse which affect the photosynthetic and transpiration processes are humidity, moisture content in the soil, the illumination and the temperature.

Since all these parameters are interlinked, a closed loop (feedback) control system is employed in monitoring it. The sensors used in this system are:

1. Soil Moisture Sensor (Transistor Amplifier)
2. Light Sensor (Light Dependent Resistor-LDR)
3. Humidity Sensor (Transistor Amplifier)
4. Temperature Sensor (LM35)

Soil Moisture Sensor

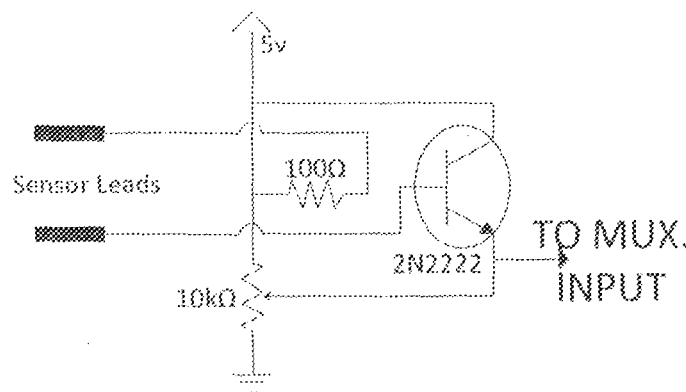

Fig. 3.2 Soil moisture sensor

The circuit designed uses a 5V supply, fixed resistance of 100Ω, variable resistance of 10KΩ, two copper leads as the sensor probes and a 2N2222 NPN transistor. It gives a voltage output corresponding to the conductivity of the soil. The conductivity of soil depends upon the amount of moisture present in it. It increases with increase in the water content of the soil.

The voltage output is taken at the transmitter which is connected to a variable resistor. This variable resistance is used to adjust the sensitivity of the sensor.

The two copper leads act as the sensor probes. They are immersed into the specimen soil whose moisture content is under test. The soil is examined under three conditions:

- **Dry condition-** The probes are placed in the soil under dry conditions and are inserted up to a fair depth of the soil. As there is no conduction path between the two copper leads the sensor circuit remains open. The voltage output of the emitter in this case ranges from 0 to 0.9V.

- **Optimum condition-** When water is added to the soil, it percolates through the successive soil layers and spreads across due to capillary force. This water increases the moisture content of the soil. This forms a conductive path between the two sensor probes leading to a close path for the current flowing from the supply to the transistor through the sensor probes. The voltage output of the circuit taken at the emitter of the transistor in the optimum case ranges from 0.9 to 3.4V approximately.
- **Excess water condition-** With the increase in water content beyond the optimum level, the conductivity of the soil increases drastically and a steady conduction path is established between the two sensor leads and the voltage output from the sensor increases no further beyond a certain limit. The maximum possible value for it is not more than 4.3V.

The output of soil moisture is connected to the multiplexer input.

Light Sensor

Light Dependent Resistor (LDR) also known as photoconductor or photocell, is a device whose resistance varies inversely with the intensity of light that falls upon it [11]. Since LDR is extremely sensitive in visible light range, it is well suited for the proposed application.

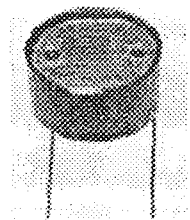

Fig. 3.3 Light Dependent Resistor

The Light Dependent Resistor (LDR) is made using the semiconductor Cadmium Sulphide (CdS). The light falling on the brown zigzag lines on the sensor causes the resistance of the device to fall or rise depending on whether the LDR is a negative or positive co-efficient. This is possible since incident photons drive electrons from the valence band into the conduction band.

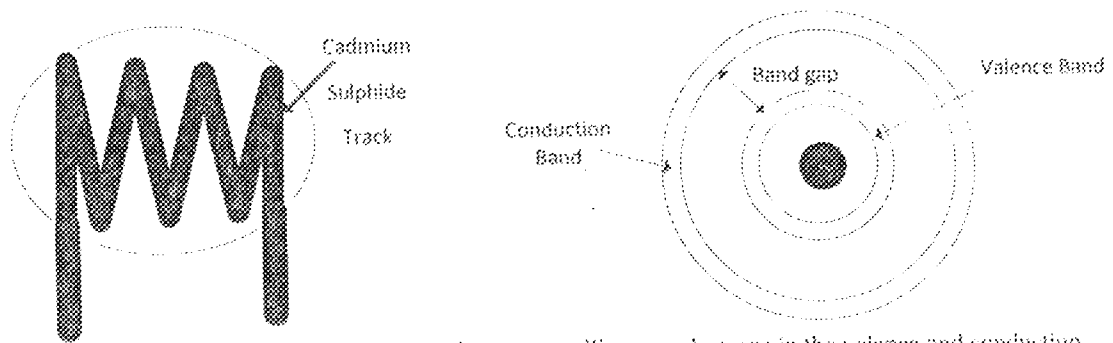

Fig. 3.4 Structure of a LDR, showing CdS track and an atom to illustrate electrons in the valence and conduction bands

An LDR and a normal resistor are wired in series across a voltage, as shown in the circuit below. Depending on which is tied to the 5V and which to ground, the voltage at the point between them (call it the sensor node) will either rise or fall with increasing light. If the LDR is the component tied directly to the 5V, the sensor node will increase in voltage with increasing light. The LDR's resistance can reach 100k ohms in dark conditions and about 100 ohms in full brightness.

The circuit used for sensing light in our system uses a 100kΩ fixed resistor which is tied to +5V. Hence the voltage value in this case decreases with increase in light intensity.

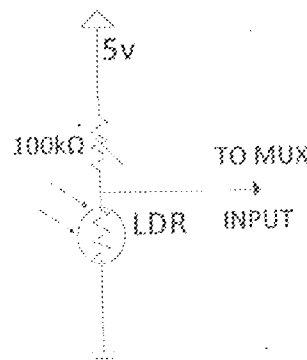

Fig. 3.5 Light sensor

The sensor node voltage is compared with the threshold voltages for different levels of light intensity corresponding to the four conditions- OPTIMUM, DIM, DARK and NIGHT.

The relationship between the resistance R_L and light intensity (Lux) for a typical LDR is:

$$R_L = \frac{500}{Lux} k\Omega \dots \dots \dots Eqn 3.3$$

With the LDR connected to 5V through a 100K resistor, the output voltage of the LDR is:

$$V_{out} = \frac{R_{bottom} \times V_{in}}{(R_{bottom} + R_{top})} \dots \dots \dots Eqn 3.4$$

$$V_{out} = \frac{5 \times R_I}{R_I + 100} \dots \dots \dots Eqn 3.5$$

In order to increase the sensitivity of the sensor we must reduce the value of the fixed resistor in series with the sensor. This may be done by putting other resistors in parallel with it.

Humidity Sensor

Relative humidity is a measure, in percentage, of the vapour in the air compared to the total amount of vapour that could be held in the air at a given temperature. The change in the RH of the surroundings causes an equivalent change in the voltage output.

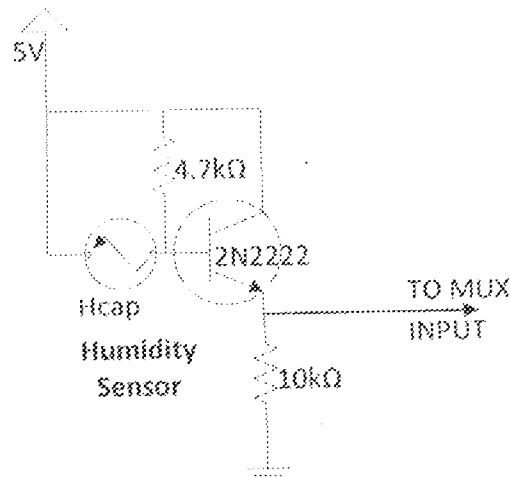

Fig 3.6 Humidity sensor circuit

The circuit was designed in the NANOLAB of the University of California, San Diego, by Professor Michael J. Sailor.

The circuit uses a 2N2222 NPN transistor to amplify the signal from the humidity (water) sensor. The humidity sensor works by electrical conductivity; when water vapour condenses on its plates, it forms a thin film that conducts electricity between the two plates. In that sense, the water sensor is like a resistor except that its resistance value changes

depending on the amount of water in the air. It was made by clipping the top off of a 30 pF capacitor using a pair of wire clippers.

The voltage output gives the absolute humidity of the environment and it's then converted to its corresponding relative humidity (typical at 27°C) using Eqn. 3.6 below.

$$RH = \frac{V_{out}}{(0.000002T^4 + 0.0002T^3 + 0.337T) + 4.9034} \dots \dots \dots Eqn 3.6$$

This voltage is converted to digital data by the ADC when selected by the microcontroller via the multiplexer, and then sent as input to the microcontroller for the appropriate operation.

Temperature Sensor

National Semiconductor's LM35 IC has been used for sensing the temperature. It is an integrated circuit sensor that can be used to measure temperature with an electrical output proportional to the temperature (in °C). The temperature can be measured more accurately with it than using a thermistor. The sensor circuitry is sealed and not subject to oxidation, etc.

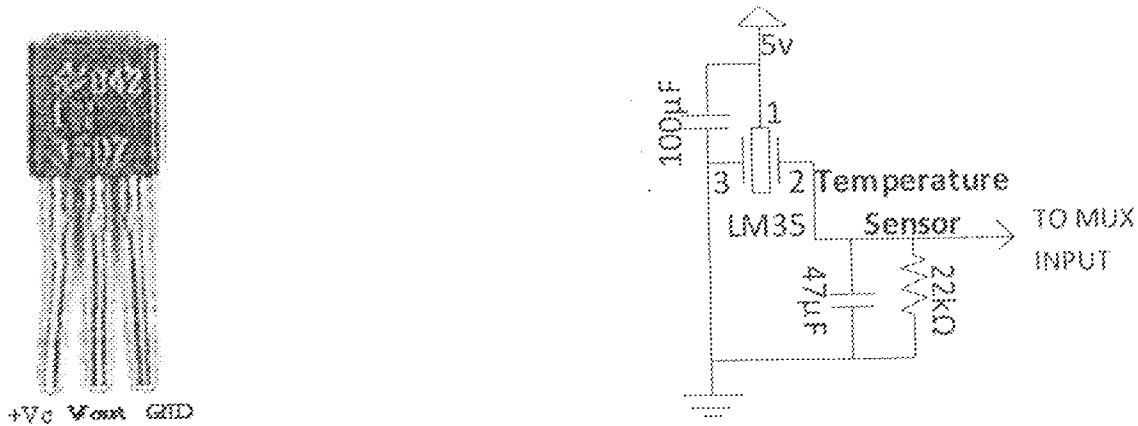

Fig. 3.7 LM35 temperature sensor and Temperature sensor circuit

The sensor has a sensitivity of 10mV/°C and voltage output that varies linearly with temperature. The output voltage is converted to temperature by a simple conversion factor. The general equation used to convert output voltage to temperature is:

$$\text{Temperature (}^\circ\text{C)} = V_{out} \times 100/1^\circ\text{C} \dots \dots \dots Eqn 3.7$$

The circuitry measures temperatures with a resolution of up to 0.5 degree Celsius. The 100 μ F capacitor is a bypass capacitor from V_{IN} to ground and a series R-C damper employing 22k Ω resistor and a 47 μ F capacitor to protect the LM35 from electromagnetic sources (e.g. relays) so that its wiring will not act as a receiving antenna and its internal junctions as rectifiers.

3.3 Multiplexing Unit (MU)

The unavailability of an ADC with multiplexing capability such as the ADC0808/0809 in the local Nigerian market brought the need to use a multiplexer to select 1 of 4 outputs of the various sensors for digitisation. The multiplexer chosen is the Fairchild's CD4052BC. It is a differential 4-channel multiplexer having two binary control inputs, A and B, and an inhibit input. The two binary input signals select 1 or 4 pairs of channels to be turned on and connect the differential analog inputs to the differential outputs. Figure 3.8 below shows the truth table for channel selection and pin description of CD4052BC.

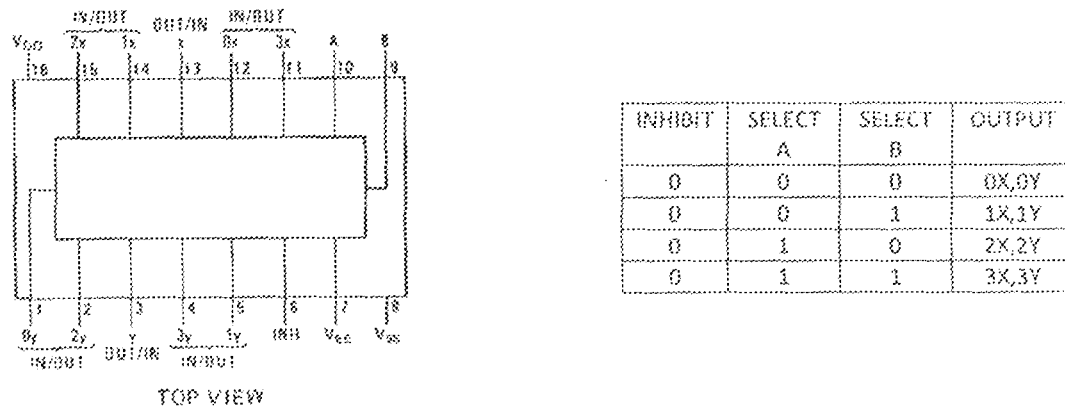

Fig. 3.8 Truth table for channel selection and pin description of CD4052BC

As can be seen in figure 3.9, the sensors are connected to the μ -input and outputted via the ν -output (pin 3) of the CD4052 to the ADC $V_{IN}(+)$.

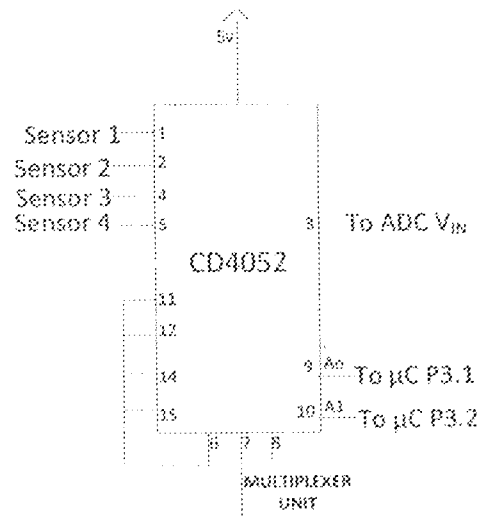

Fig. 3.9 the Multiplexing unit

3.4 Analog to Digital Converter (ADC)

Physical world parameters such as temperature, pressure, humidity, and velocity are analog signals. We need an analog to digital converter (ADC), which is an electronic circuit that converts continuous signals into discrete form so that the microcontroller can read the data. The ADC0804 is a CMOS 8-bit successive approximation A/D converter that uses a differential potentiometric ladder - similar to the 256R products. This converter is designed to allow operation with the NSC800 and INS8080A derivative control bus with TRI-STATE output latches directly driving the data bus. These A/Ds appear like memory locations or I/O ports to the microprocessor and no interfacing logic is needed. Differential analog voltage inputs allow increasing the common-mode rejection and offsetting the analog zero input voltage value. In addition, the voltage reference input can be adjusted to allow encoding any smaller analog voltage span to the full 8 bits of resolution - this is supplied to the ADC via pin 13 of the multiplexer - and has an access time of 135 ns. The device offers high speed, high accuracy, minimal temperature dependence, excellent long-term accuracy and repeatability, and consumes minimal power. These features make it ideally suited for applications from process and machine control to consumer and automotive applications.

The clocking of the chip is controlled by a resistor and capacitor connected to CLKR and CLKin to give a minimum of 640 kHz. From Equation 2.4, resistance of 10k and a capacitor of 100 pF give a frequency of 909 kHz.

The 8-bit output from the ADC is given to Port 1 of the microcontroller and the control signal WR is connected to port 3.0 of the microcontroller, while RD, CS, Analog Gnd, Digital Gnd and $V_{IN(-)}$ are grounded as seen in figure 3.10.

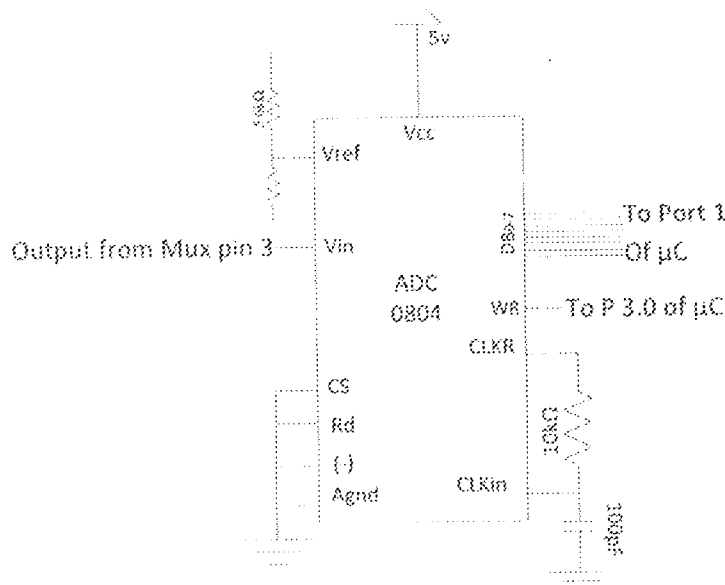

Fig. 3.10 ADC Unit

3.5 Microcontroller (AT89C52)

The microcontroller is the heart of the proposed embedded system. It constantly monitors the digitized parameters of the various sensors and verifies them with the predefined threshold values and checks if any corrective action is to be taken for the condition at that instant of time. In case such a situation arises, it activates the actuator or powers an LED to either perform a controlled operation or simulate it. The pin function and features of this IC have been discussed in the previous chapter (i.e. chapter two). Its operation in the circuit is programmed in C programming language with Keil μ Vision3. The flow chat of the program is shown in chart 3.1 page 35. See appendix I page 47, for the program code.

The basic criteria for choosing a microcontroller suitable for the application are:

1) It must meet the task at hand efficiently and cost effectively. In analyzing the needs of a microcontroller-based project, it is seen whether an 8-bit, 16-bit or 32-bit microcontroller can best handle the computing needs of the task most effectively.

Among the other considerations in this category are:

- Speed: The highest speed that the microcontroller supports.
- Packaging: It may be a 40-pin DIP (dual inline package) or a QFP (quad flat package), or some other packaging format. This is important in terms of space, assembling, and prototyping the end product.
- Power consumption: This is especially critical for battery-powered products.
- The number of I/O pins and the timer on the chip.
- How easy it is to upgrade to higher performance or lower consumption versions.
- Cost per unit: This is important in terms of the final cost of the product in which a microcontroller is used.

2) Ease in developing products around it. Key considerations include the availability of an assembler, debugger, compiler, technical support.

3) Availability in needed quantities both now and in the future.

Currently of the leading 8-bit microcontrollers, the 8051 family has the largest number of diversified suppliers. By supplier, it is meant a producer besides the originator of the microcontroller. In the case of the 8051, this has originated by Intel but several companies currently produce it. Thus, the microcontroller AT89C52, satisfying the criterion necessary for the proposed application is chosen for the task.

The AT89C52 is a low-power, high-performance CMOS 8-bit microcontroller with 8K bytes of in-system programmable Flash memory. The device is manufactured using Atmel's

high-density non-volatile memory technology and is compatible with the industry standard 80C51 instruction set and pin-out. The on-chip Flash allows the program memory to be reprogrammed in-system or by a conventional non-volatile memory programmer.

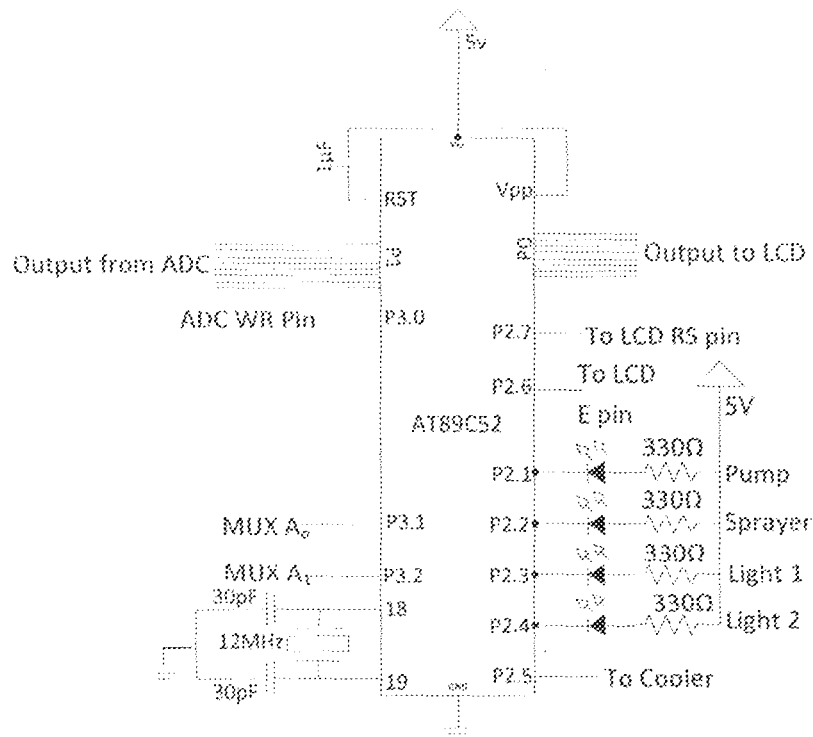

Fig. 3.11 Microcontroller Unit Circuit

It uses a 12MHz quartz crystal oscillator to provide the basic internal frequency of the microcontroller for the internal counters to divide the basic clock rate to yield standard communication bit per second (baud) rates and timing. The microcontroller is interfaced with the ADC in polling mode. Port 0 is interfaced with the LCD data lines. Port 1 is interfaced with the ADC data lines, Port 2 is interfaced with the LCD Control lines (P2.6 and P2.7) and AC Interface control (relay connected to a fan and LEDs simulating pump, sprayer, and lights), and Port 3 is interfaced with the ADC and multiplexer control lines.

The LEDs used for the simulation of the actual devices are connected via resistors calculated thus;

$$V_{LED} = 0.7V, V_s = 5V, \text{ and } I_{LED} = 15mA;$$

$$R_s = \frac{V_s - V_{LED}}{I_{LED}} \dots \dots \dots \text{Eqn 3.8}$$

$$R_s = \frac{5 - 0.7}{15 \times 10^{-3}} = 286 \Omega$$

330Ω resistors are used as current limiters, to keep the light emitting diode within its specified operating limits. The LEDs are connected so that the microcontroller sinks current.

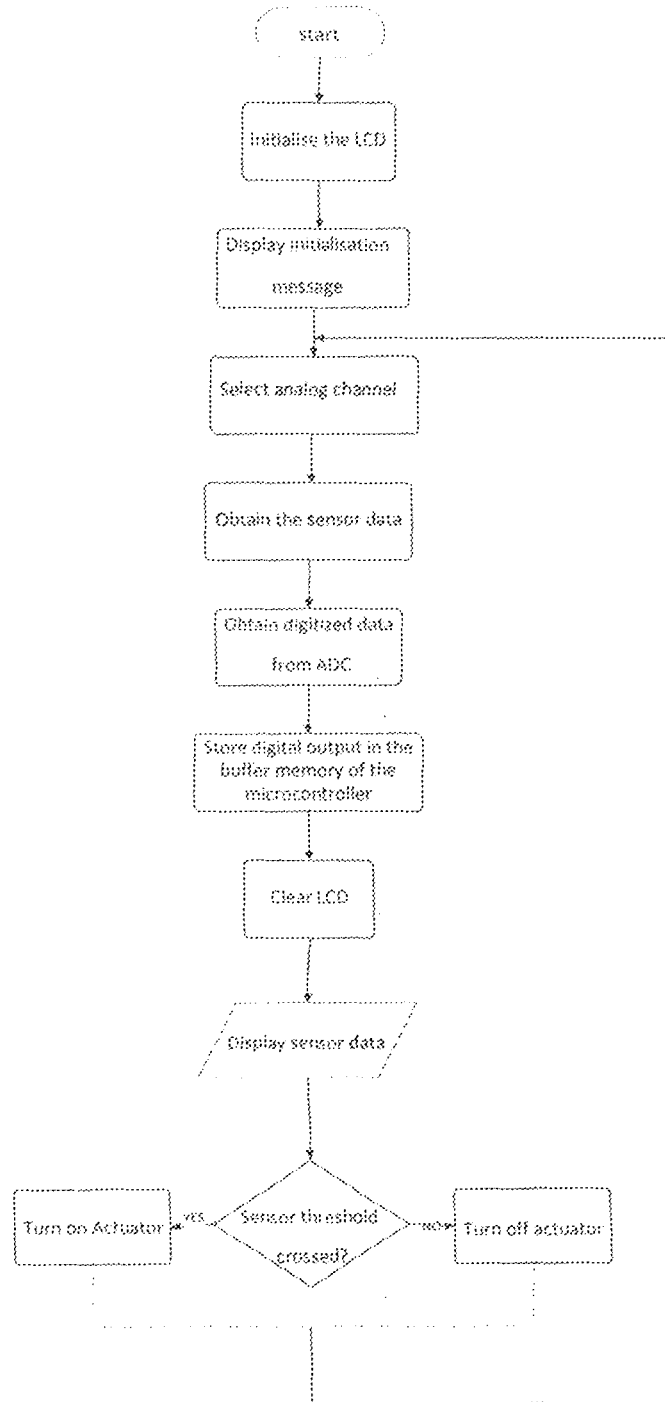

Chart 3.1. Flow Chart

3.6 Actuator Unit (AU)

A 6V relay is used to switch the load (fan) because it is able to control an output circuit of higher power than the input circuit. The coil is energised from a low power source (a transistor) while the contacts can switch high powers such as the mains supply. When a coil is switched off, a large BACK EMF appears across the coil; hence, 1N4001 diode is connected across the coil of the relay to protect the relay and other circuitry from the back emf.

Since a positive supply is involved, 1015GR PNP Transistor is used. For 1015GR PNP Transistor with I_B (base current) = 20mA, V_O = 5V from power supply, V_{BE} (sat) = 1.1V_{DC}, Current gain (h_{FE}) = 71 and a feedback resistor taken as 2.7k Ω

$$R_B = \frac{V_O - V_{BE} - \beta I_B R_C}{I_B} \dots \dots \dots \text{Equ 3.9}$$

$$R_B = \frac{5 - 1.1 - (71 \times 2.7 \times 20 \text{mA})}{20 \text{mA}}$$

$$R_B = (0.066) / 20 \text{mA} = 3.3$$

R_B was chosen to be 2.7K Ω

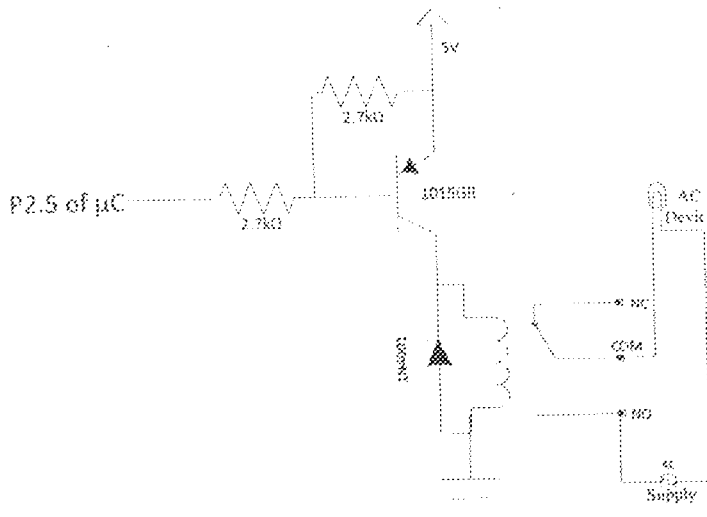

Fig. 3.12 Actuating Unit

3.7 Display Unit (DU)

The system uses an LCD designed around Hitachi's LCD HD44780 module - which is inexpensive, easy to use, and even possible to produce a readout using the 8x80 pixels of the display - to output visual information.

The 8-bit data bus is connected to port 0 of the microcontroller. Enable (E) and Register Select (RS) are connected to port 2.6 and port 2.7 respectively for control. Read/Write is connected to ground to provide logic 0 (zero), since the LCD is only written to and not read from in the system. Pin 16 was grounded, while pin 15 was connected to Vcc via a 330Ω resistor calculated as in section 3.5 (being an LED for backlight). The display requires a +5V supply fed in through pin 2. Pin 1 is grounded and pin 3 provides contrast by varying a 20kΩ variable resistor. When the LCD display is not enabled, data lines are tri-state and they do not interfere with the operation of the microcontroller

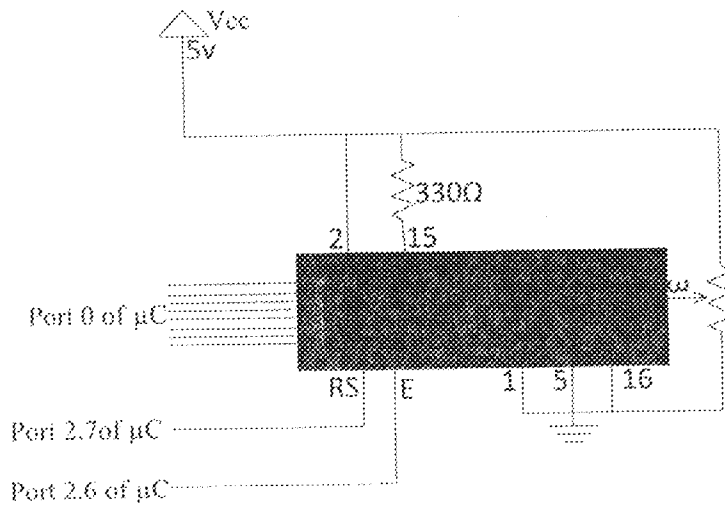

Fig. 3.13 Display Unit

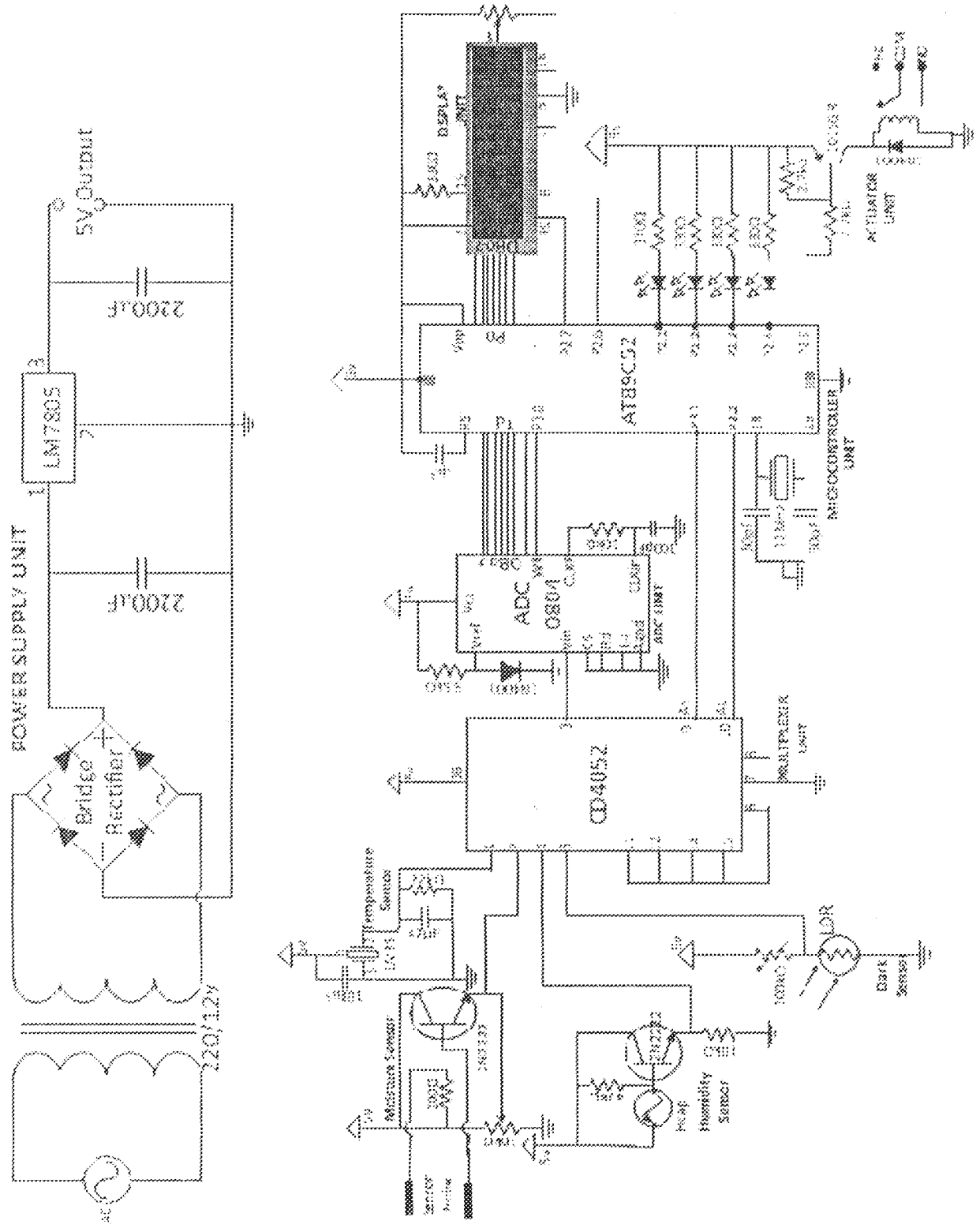

Fig 3.14 Complete circuit diagram

CHAPTER FOUR

TEST, RESULT AND DISCUSSION

4.1 Construction

In construction, a number of decisions were made on the choice of components. First, the components were laid on breadboard which was positive in response. The construction of the project was done in two different stages: the soldering of the circuits and coupling of the entire project to the casing. The soldering of the circuit was done on a Vero board. Some of the construction tools used during the modelling and hardware construction are giving below.

1. **DIGITAL MULTIMETER:** This instrument was used to measure voltage, resistance, continuity, current and frequency. The process of implementation of the design on the veroboard required the measurement of the parameters like, voltage, continuity, resistance values of the components and in some cases frequency measurement.
2. **OSCILLOSCOPE:** This instrument was used to observe the ripples in the power supply wave form and to ensure that all waveforms are correct and their frequencies are accurate.
3. **PROGRAMMER:** The programmer used is a powerful programmer for the Atmel 89 series of microcontrollers that includes 89C51/52/55, 89S51/52/55 and many more. The Programmer comes with window based software for easy programming of the devices known as 'ProLoad' (Program Loader).

The circuit operation as proposed in chapter 1 was implemented but due to the impossibility of getting the entire components with designed values, some approximation and compromise have been introduced in the original design.

4.2 Testing

The testing and implementation process involved the use of some equipment such as multimeter and oscilloscope. Stage by stage testing was done according to the block representation on the breadboard, before soldering of circuit commenced on Vero board. The project was implemented and tested to ensure its working ability.

Transducer Readings

All readings were taken at room temperature of 27°C with supply voltage of 4.98V.

Soil Moisture Sensor

Tolerance = ± 0.2 V

Table 4.1 Soil moisture sensor readings

SOIL CONDITION	TRANSDUCER OPTIMUM RANGE
DRY	0 – 0.9V
OPTIMUM	1.0- 3.5V
SLURRY	3.5 – 4.3V

Light Sensor

Tolerance = ± 0.1 V

Table 4.2 Light sensor readings

ILLUMINATION STATUS	VOLTAGE RANGE
OPTIMUM	0V-1.25V
DIM	1.26V- 2.5V
DARK	2.6V – 3.75V
NIGHT	3.75V - 5V

Humidity Sensor

FORMULA:

$$RH = \frac{V_{out}}{(0.000002T^4 + 0.0002T^3 + 0.337T) + 4.9034} \dots \dots \dots Ref\ to\ Eqn\ 3.6$$

Tolerance= ±0.1V

Table 4.3 Humidity sensor readings

RELATIVE HUMIDITY % RH	TRANSDUCER OUTPUT RANGE
0 to 1%	0.00 - 0.23mV
1 to 9.99%	0.23 - 1.90mV
9.99 to 19.9%	1.90 - 3.80mV
19.90 to 29.90%	3.80 - 5.70mV
29.90 to 39.90%	5.70 - 7.60mV
39.90 to 49.90%	7.60 - 9.50mV
49.90 to 59.90%	9.50 - 11.40mV
59.90 to 69.90%	11.40 - 13.30mV
69.90 to 79.90%	13.30 - 15.20mV
79.90 to 89.90%	15.20 - 17.10mV
89.90 to 99.90%	17.10 - 19.00mV

Temperature Sensor

FORMULA:

$$\text{Temperature (}^\circ\text{C)} = V_{out} \times 100/1^\circ\text{C} \dots \dots \dots Ref.\ Eqn\ 3.7$$

Table 4.4 Temperature sensor readings

TEMPERATURE	SENSOR OUTPUT
0 ^o - 10 ^o C	0.00-0.10V
10 ^o - 20 ^o C	0.10-0.20V
20 ^o - 30 ^o C	0.20-0.30V
30 ^o - 40 ^o C	0.30-0.40V
40 ^o - 50 ^o C	0.40-0.50V
50 ^o - 60 ^o C	0.50-0.60V
60 ^o - 70 ^o C	0.60-0.70V
70 ^o - 80 ^o C	0.70-0.80V
80 ^o - 90 ^o C	0.80-0.90V
90 ^o - 100 ^o C	0.90-1.00V

Discussion of Result

The results obtained from the measurement have shown that the system performance is quite reliable and accurate. Since it is able to measure the parameters both within and outside the optimum range, the microclimatic conditions of the plants are modified to their optimum.

4.3 Problem Encountered

Several problems were encountered during the project. The problems include, design problem, implementation problems and also construction problem. The major problems are as follow:

1. The actual calculated values for some component were not available. Preferred values were used instead.
2. Problem was encountered in locating a suitable humidity sensor from the local market. The problem was solved by using a transistor amplifier air moisture sensor.
3. Other problem includes soldering and measurement errors but these problems were solved by proper troubleshooting and serious care in the construction of the project.

System Installation and Fault Reduction:

1. The system has to be provided with uninterrupted power supply and should be installed with care, in a place where the changes in microclimatic parameters are well pronounced.
2. For best results with the moisture sensor, the probes must be inserted into the specimen soil when the soil is dry.
4. For best results with the humidity sensor, do not expose sensor to condensing environments. Exposure to condensing environments will cause sensor output to indicate 0 %RH.

- For best results with the temperature sensor, the LM35 and accompanying wiring and circuits must be kept insulated and dry, to avoid leakage and corrosion. Printed-circuit coatings and varnishes such as Humiseal and epoxy paints or dips can be used to insure that moisture does not corrode the LM35 or its connections.

Troubleshooting:

- In case of a system hang-up condition, the system should be restarted by switching it OFF and ON. This revives the system.
- In case of anomalies in the readings of the humidity sensor, it is recommended that the sensor be kept in an air-tight container with silica-gel inside.
- In case of anomalies with the moisture sensor, the probes can be stripped off the soil or mud particles deposited on its surface and in case of sensor leads oxidation; it is recommended that the leads be replaced.

4.4 List of Components

S/N	ITEM	QUANTITY
1	TRANSFORMER	1
2	DIODE IN4001	6
3	CAPACITOR	8
4	RESISTOR	16
5	CD 4052 (MULTIPLEXER)	1
6	ADC 0804	1
7	AT89C52	1
8	LED	4
9	2x16 MATRIX LCD	1
10	LM35	1
11	NPN TRANSISTOR (2N2222)	2
12	PNP 1015GR	1
13	7805 REGULATOR	1
14	LDR	1
15	RELAY	1
16	12MHz CRYSTAL OSCILLATOR	1

CHAPTER FIVE

CONCLUSION

5.1 Summary

A step-by-step approach in designing a microcontroller based system for measurement and control of four essential parameters for plant growth, i.e. temperature, humidity, soil moisture, and light intensity, has been followed.

When any of the essential parameters crosses a safety threshold which has to be maintained to protect the crops, the sensors sense the change and the microcontroller reads this from the data at its input ports after being converted to a digital form by the ADC. The microcontroller then performs the needed actions until the strayed-out parameter has been brought back to its optimum level.

5.2 Conclusion

The results obtained from the measurement have shown that the system performance is quite reliable and accurate.

The system has successfully overcome quite a few shortcomings of the existing systems by reducing the power consumption, maintenance and complexity, at the same time providing a flexible and precise form of maintaining the environment.

The continuously decreasing costs of hardware and software, the wider acceptance of electronic systems in agriculture, and an emerging agricultural control system industry in several areas of agricultural production, will result in reliable control systems that will address several aspects of quality and quantity of production.

5.3 Recommendation

1. The performance of the system can be further improved in terms of the operating speed, memory capacity, and instruction cycle period of the microcontroller by using other controllers such as AVR's and PIC's. The number of channels can be increased to

interface more number of sensors which is possible by using advanced versions of microcontrollers.

2. The system can be modified with the use of a datalogger and a graphical LCD panel showing the measured sensor data over a period of time.
3. A speaking voice alarm or a buzzer could be used to inform the farmer of changes in the monitor parameter.
4. This system can be connected to communication devices such as modems, cellular phones or satellite terminal to enable the remote collection of recorded data or alarming of certain parameters.
5. The device can be made to perform better by providing the power supply with the help of battery source which can be rechargeable or non-rechargeable, to reduce the requirement of main AC power.
6. Time bound administration of fertilizers, insecticides and pesticides can be introduced.
7. Further improvements will be made as less expensive and more reliable sensors are developed for use in agricultural production.

Although the enhancements mentioned in section 5.3 may seem far in the future, the required technology and components are available, many such systems have been independently developed, or are at least tested at a prototype level. Also, integration of all these technologies is not a daunting task and can be successfully carried out.

REFERENCE

1. Encyclopædia Britannica. "Greenhouse effect." Ultimate Reference Suite. Chicago: 2010.
2. C.R Adams, K. M Bamford and M. P Early. Principles of Horticulture, 3rd Ed., 1998, pp 1-3, 28-32.
3. Anthony N., "Climate Change --the Role of Food and Agricultural Trade". UNFCCC COP 13, Poznan, Poland, December 2008, pp. 1-17
4. George Aquash. Horticulture: Principles and Practices, 2nd Ed., Pearson Education, Singapore, 2002, pp 149-160, 425-440.
5. Microsoft® Student 2005 [DVD]. "Greenhouse." Redmond, WA: Microsoft Corporation, 2007.
6. J. Stuehlfe, Plants and Temperature. Edward Arnold, 1977.
7. Buckford, E. D and Dun, S., Lighting for Plant Growth, Kent State Univ. Press, 1973
8. Paul Horowitz and Winfield Hill. Art of Electronics, 2nd edition, 1994, pp61-88
9. Encyclopædia Britannica. "Greenhouse." Ultimate Reference Suite. Chicago: Encyclopædia Britannica, 2010.
10. Encyclopædia Britannica. "Agricultural Technology." Ultimate Reference Suite. Chicago: Encyclopædia Britannica, 2010.
11. B.L. Theraja and A.K. Theraja: "Electrical Technology" S-Chand and Company Limited, 2006, pp2094-2095.
12. Eily Nederhof, Commercial Grower 52(7), Crop house Ltd., New Zealand, 1997, pp.29-30
13. John Hughes, Starting a Commercial Greenhouse Business, July, 2003
14. Ronald J. Tocci and Neal S. Widmer, Digital Systems: Principles and Applications, 8th Ed., Pearson Education, Inc, 2005, pp 502-639.
15. Hitachi HD44780 datasheetHD44780 Data, Available from a number of websites, including <http://www.electronic-engineering.ch/microchip/index.html>
16. Atmel 8051 Microcontroller Hardware Manual (2004), Atmel Corporation, Ref. 4316C-8051-05/04; <http://www.atmel.com/>
17. Gorgoni Rizzona, Principle And Application Of Electrical Engineering
18. Stan Giblisco, The Illustrated Dictionary of Electronics, 8th Ed., McGraw-Hill Companies, Inc, 2001
19. D. Stipanović, M. Ćur and J. Marasović. "Networked Embedded Greenhouse Monitoring and Control". Proceedings of 2003 IEEE Conference on Control Applications, June 2003, pp. 1-5

APPENDIX I

```
#include<reg51.h> #include<intrins.h>

#include <stdio.h>

//*****

#define adc_port P1 #define led_port P0

#define t_base 250 #define seconds_reload 4000

#define temperature_scale 2.125 #define light_scale 2.55

#define humidity_scale 2.55 #define moisture_scale 1.00

#define humidity_prescale 1.00 #define size 8

sbit led_rs=P3^3; sbit led_en = P3^4;

sbit temp_relay_dx = P2^0; sbit light_relay1_dx= P2^1;

sbit light_relay2_dx=P2^2; sbit humidity_relay_dx= P2^3;

sbit moisture_led= P2^4; sbit temp_relay2_dx=P2^5;

sbit a0_dx= P3^6; sbit a1_dx=P3^7;

sbit adc_write=P3^2;

//*****

volatile bit time_ok; volatile unsigned char idata light, humidity, temperature, moisture;

volatile unsigned char idata upper_humidity, lower_humidity;
```

```

volatile unsigned char idata temperature_buffer[size];

volatile unsigned char idata light_buffer[size]; volatile unsigned char idata
humidity_buffer[size];

volatile unsigned char idata moisture_buffer[size]; volatile unsigned int count;

void show_params(void); void show_id(void);

/*****

void tf1_isr(void) interrupt 3

{
    if(!--count)

        time_ok=1;

        count=seconds_reload;

}

}

/*****

void start_timer1(void)

{
    TF1=0;    TR1=1; }

/*****

void start_timer0(void)

{
    TF0=0;    TR0=1; }

```



```

//*****

void stop_timer0(void)

{
    TR0=0; TF0=0; }

//*****

void delay(unsigned int z)

{
    stop_timer0();

    start_timer0();

    while(z)

        {
            while(TF0); TF0=0;

            z--; }

    stop_timer0(); }

//*****

void write(unsigned char c,unsigned char reg_select)

{
    lcd_en=0;

    lcd_rs=reg_select;    lcd_port=c;

    lcd_en=1;    lcd_cn=0; }

//*****

void lcd_data(unsigned char c)

```

```

{   write(c,1);

    delay(500/t_base); }

//*****

void lcd_cmd(unsigned char c)

{   write(c,0); delay(2000/t_base);   }

//*****

void clear_lcd(void)

{   lcd_cmd(0x01); }

//*****

void lcd_pos(unsigned char row, unsigned char pos)

{   if(row==1)lcd_cmd(0x80+pos);

    if(row==2)lcd_cmd(0xc0+pos); }

//*****

void lcd_string(unsigned char code *p)

{   while(*p)lcd_data(*p++); }

//*****

void lcd(unsigned char data *ptr)

{   while(*ptr)lcd_data(*ptr++); }

```

```
//*****
```

```
void init_led(void)
```

```
{    lcd_cmd(0x38);    delay(15000/t_base);
```

```
    lcd_cmd(0x38); delay(2);
```

```
    lcd_cmd(0x38); delay(2);
```

```
    lcd_cmd(0x0c); delay(2);
```

```
    lcd_cmd(0x01);    delay(2000/t_base);
```

```
    lcd_cmd(0x06);    delay(2000/t_base); }
```

```
//*****
```

```
unsigned char get_adc(unsigned char select)
```

```
{    unsigned char z;    switch(select)
```

```
{    case temperature_select:    a0_dx=0;a1_dx=0;break;
```

```
    case light_select:            a0_dx=1;a1_dx=0;break;
```

```
    case humidity_select:        a0_dx=0;a1_dx=1;break;
```

```
    case moisture_select:        a0_dx=1;a1_dx=1;break;
```

```
    default:                    return 0;    }
```

```
    delay(1000/t_base);
```

```
    adc_write=0; nup_();adc_write=1;
```

```

        z=200; while(--z);    return adc_port; }

//*****

void compute_light(void)

{
    unsigned char x;        float z=0.00;

    for(x=0;x<size;x++)light_buffer[x]=light_buffer[x+1];

    light_buffer[size-1]=get_adc(light_select);

    for(x=0;x<size;x++)z+=light_buffer[x];

    z/=size; light=z/light_scale;

    if(light>100)light=100; }

//*****

void compute_temperature(void)

{
    unsigned char x;        float z=0.00;

    for(x=0;x<size;x++)temperature_buffer[x]=temperature_buffer[x+1];

    temperature_buffer[size-1]=get_adc(temperature_select);

    for(x=0;x<size;x++)z+=temperature_buffer[x];

    z/=size;

    temperature=z/temperature_scale; }

//*****

```

```

void compute_humidity(void)
{
    unsigned char x;

    float z=0.00;

    for(x=0;x<size;x++)humidity_buffer[x]=humidity_buffer[x+1];

    humidity_buffer[size-1]=get_adc(humidity_select);

    for(x=0;x<size;x++)z+=humidity_buffer[x]; z/=size;

    humidity =z/humidity_scale;

    if(humidity>100)humidity=100;

    if(humidity<100)

    {
        x=humidity/19.001882;

        x*=100;          humidity=x;
    }
}

```

/******

```

void compute_moisture(void)
{
    unsigned char x;    float z=0.00;

    for(x=0;x<size;x++)moisture_buffer[x]=moisture_buffer[x+1];

    moisture_buffer[size-1]=get_adc(moisture_select);

    for(x=0;x<size;x++)z+=moisture_buffer[x]; z/=size;
}

```

```

    moisture=z/moisture_scale; if(moisture>100)moisture=100; }

//*****

void compute_params(void)

{   compute_light();   compute_humidity();

    compute_temperature();   compute_moisture(); }

//*****

void init_timer(void)

{   TCON=0x00; TMOD=0x22;

    TH0=256UL-t_base; TL0=256UL-t_base;

    TH1=256UL-t_base; TL1=256UL-t_base; }

//*****

void init_params(void)

{   unsigned char x;

    lower_humidity=20; upper_humidity=50;

    for(x=0;x<size;x++)

    {   temperature_buffer[x]=0;   light_buffer[x]=0;

        humidity_buffer[x]=0;   moisture_buffer[x]=0;   }

    for(x=0;x<size;x++)temperature_buffer[x]=get_adc(temperature_select);

```

```

for(x=0;x<size;x++)light_buffer[x]=get_adc(light_select);

for(x=0;x<size;x++)humidity_buffer[x]=get_adc(humidity_select);

for(x=0;x<size;x++)moisture_buffer[x]=get_adc(moisture_select);

compute_params(); }

//*****

void init_output(void)

{   temp_relay_dx=1;   temp_relay2_dx=1;

    light_relay1_dx=1;   light_relay2_dx=1;

    humidity_relay_dx=1;moisture_led=1; }

//*****

void init_irq(void)

{   ET0=1; }

//*****

void sys_init(void)

{   IE=0x00;

    init_timer();   init_params();

    init_led();   show_id();

    init_output();   count=seconds_reload;

```

```

    init_irq(); EA=1;    time_ok=0; }

/*******

unsigned char to_ascii(unsigned char c)

{    if((c>=0)&&(c<=9))return (c+'0'); else return (c+'7');

}

/*******

void format(unsigned char data *s,unsigned char c)

{    *s=to_ascii((c/100)); s++;

    *s=to_ascii((c%100)/10); s++;

    *s=to_ascii((c%100)%10); s++;

    *s=0x00; }

/*******

void show_params(void)

{    unsigned char data buffer1[8],buffer2[8];

    format(buffer1,temperature);

    format(buffer2,humidity);    clear_led();

    led_post(1,0);led_string("T: ");led(buffer1);led_data(223);led_data('C');

    led_post(1,9);

```



```

if(light<=25)led_string("L: NIT");

if((light>=26)&&(light<=50))led_string("L: DRK");

if((light>=51)&&(light<=75))led_string("L: DIM");

if(light>=76)led_string("L: OPT");

led_pos(2,9);led_string("H: ");led(buffer2);led_data("%");

led_pos(2,9);

if(moisture<10)led_string("M: DRY");

if((moisture>= 10)&&(moisture<=70))led_string("M: OPT");

if(moisture>70)led_string("M: SLU"); }

```

```

//*****

```

```

void show_id(void)

```

```

{   clear_led();

    led_pos(1,0); led_string("tadi daniel v.");

    led_pos(2,0); led_string(" 2005/22100ee ");

    delay(2000000/t_base);

    clear_led();

    led_pos(1,0); led_string(" project title: ");

    led_pos(2,0); led_string(" project green ");
}

```

```

delay(2000000/t_base);    clear led);

led_pos(1,0); led_string(" supervisor: ");

led_pos(2,0); led_string(" Mr.Bala Safihu ");

delay(2000000/t_base); }

/*****

void compare_params(void)

{    if((light<25)||((light>=76))

    {    light_relay1_dx=1; light_relay2_dx=1;    }

    if((light>=26)&&(light<=50))light_relay1_dx=0;

    if((light>=51)&&(light<=75))light_relay2_dx=0;

    if(temperature>36)temp_relay_dx=0; else temp_relay_dx=1;

    if(moisture<10)moisture_led=0; else moisture_led=1; }

/*****

void main(void)

{    unsigned long z;    sys_init();    while(1)

    {    compute_params();

        show_params();        compare_params();

        z=75000; while(--z:    } }

```