

**DESIGN AND CONSTRUCTION OF A
PARTIAL NIGHT- TIME HOME
AUTOMATION SYSTEM**

**DANSO WILSON
2000/9818EE**

**DEPARTMENT OF ELECTRICAL AND COMPUTER
ENGINEERING**

OCTOBER, 2006

But aside the switching on, the circuit connects serially to a pest repellent – an ultrasonic pest repellent. Now, it is common knowledge that pests such as mosquitoes, bugs, cockroaches, rodents etc find the night time most conducive for their habits, and more so in urban areas where personal localized hygiene proves grossly insufficient to ward them off; owing of course to the poor waste management, occasioned by population explosion and density; coupled with poor town planning, drainage facilities and sewage disposal systems.

To thus protect one's self and family or household, it becomes imperative to devise another means to keep off these potential disease vectors. The ultrasonic circuit in this system (and project) comes in handy here.

It has been investigated and proven that there is an audible and inaudible part of sound. Below certain decibels (near the 0dB), the human ear will not be able to pick the sound data, not even to mention sending it to the brain for processing. There is also a part in the sound spectrum where we are able to make out what is being produced. This goes on to the point where it becomes too loud, uncomfortable and even harmful ($\approx 130\text{dB}$). On the other extreme is sound that though existent, but unlike the very first cannot be heard by the human ear. In this case there is sound but it goes past the human capacity to detect. This region has been found to be audible to certain creatures, the rodents, mosquitoes, cockroaches and bugs inclusive. However for them, it is not music, it is actually for them what the extreme section of the middle portion of the spectrum is to us – loud, discomfoting, threatening and harmful.

Thus, as soon as the lights are turned on, the repellent is spontaneously triggered on as well (being serially connected); and stays so until illumination improves.

The third portion of this system is the selective light-switch circuit. It is also serially connected to the illumination detector.

DESIGN AND CONSTRUCTION OF A PARTIAL NIGHT- TIME HOME AUTOMATION SYSTEM

**DANSO WILSON
2000/9818EE**

**A THESIS SUBMITTED TO THE DEPARTMENT OF
ELECTRICAL AND COMPUTER ENGINEERING,
FEDERAL UNIVERSITY OF TECHNOLOGY, MINNA IN
PARTIAL FULFILMENT OF THE REQUIREMENT FOR
THE AWARD OF A BACHELOR OF ENGINEERING
(B.ENG) DEGREE IN ELECTRICAL AND COMPUTER
ENGINEERING**

OCTOBER, 2006.

DEDICATION

To the Lord YHWH, King Eternal, the Evernal God, Who covered me, and to the first born
from the dead, whose grace I covet so dearly, I devote this dissertation and entire
undertaking.

CERTIFICATION

This is to certify that this project design and construction of a Partial Night-Time Automation System was carried out by Danso Wilson (2000/9818EE) under the supervision of Engr. M.S. Ahmed for the award of Bachelor of Engineering (B.Eng) degree in Electrical/Computer Engineering Federal University of Technology Minna..

Danso Wilson

.....
Name of Student

Engr. M.S. Ahmed

.....
(Name of Supervisor)

.....
 17 OCT, '06 A.D.
Signature and date

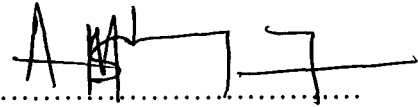
.....

Signature and date
17/10/06

Engr. M. D Abdullahi

.....
(Name of H.O.D.)

.....
(Name of External Examiner)

.....
Signature and date

.....
Signature and date

ACKNOWLEDGEMENTS

To the Lord God that has covered me, and to the LORD Jesus, who is not the best, but the ONLY (whose grace I covet) thank you.

Mr. Samuel K. Danso, His wife (Mrs. Florence A. Danso), and my mother who had to live on bare necessities to keep this theo-like arrow in this phase of time, deserve my high honor. Thanks Dad, thanks Mom – you are the best.

May my tongue cleave to the roof of my mouth if I forget Zion, the Dwelling place of Elyon. You folks were and are family beyond words. Necessarily, I'd miss you.

To my friends Michael Adejare, Chijoke Odurukwe (more gifted at heart than at hands), Goldima(sold out to my happiness), Samson Komolafe, Wale Adebayo, David Egbunu, Collins Annyawu, Douglas Igben, Comfort Auta, Oghene-Chiedu, Alex Ezuteh(for your constant reminder), Tomi and G-gokes (and Kaidee) (for emptying of your resources in heart and wallet), my Fola (for hoping against hope)and you 'Christabel', I'd always love you. I'd be at the golden shore saying my thanks in better language as the general assembly gathers.

Engineer M.D Abdullahi's leadership made schooling a lot easier. To Engr. M.S Ahmed, my most simple and understanding Supervisor, whose easy cursory eyes fruited the contents of this dissertation to this distinguished men I say I am grateful.

There is that host of distinguished YOU whose names must be reserved for better acknowledgement when THE BOOKS will be opened. For you, I consider it beneath your excellencies to be rewarded in puny print – for all your quiet, secret and sacrificial endeavors on my behalf. We'll meet there!

ABSTRACT

This project aims at partially automating a residential building using photocells and other discrete and integrated circuits. The chief considerations are security lights, dimming selected lights controlled by a Timer/Delay circuit and a pest repellent.

Table of Contents

Dedication	ii
Certification	iii
Acknowledgments	iv
Abstract	v
List of Figures	ix
List of Tables	x
Chapter One: Introduction	1
1.1 Project Brief	2
1.2 Objectives of the Project...	4
1.3 Project Methodology...	5
1.4 Scope of Work...	5
1.5 Sources of Materials	6
1.6 Constraints to Optimal Performance	6
1.7 Involvement of Others...	6
Chapter Two: Literature Review/Theoretical Background...	7
2.1 The Concept and Principle of Automation	7
2.2 A Brief History of Automation...	7
2.3 Home Automation	8
2.4 Sound	10
2.4.1 Ultrasonic: History and Principle	11
2.4.1.1 Applications of Ultrasonic	13
2.4.1.2 Effects of Ultrasonic	15

2.4.2	History and Principles of Pest Repellants...	16
2.4.2.1	Effectiveness and Limitations of Pest Repellants				16
2.5	Vision and Illumination	17
2.5.1	Basic Principles of Illumination...	17
2.5.1.1	Definition of Terms	19
2.5.2	Principle of Human Vision	20
2.5.3	Light Dimmers: Principles of Operation	21
2.5.3.1	DIACs and TRIACs	22
2.6	History and Theory of Photocells	22
2.6.1	Photocells and Light Detection	23
2.6.1.1	How Photocells Absorb Light and turn it into Power				24
2.6.2	Positioning of Photocells	26
2.6.2.1	Location Parameters of Photocells	26
2.6.2.2	Consequences of Poor Positioning	30
2.7	Evolution of IC Technology	30
2.7.1	History and Operational Principles of Timers	31
2.7.1.1	The 555 Timer	32
2.7.2	The “4000” Series	34
2.7.2.1	The CD 4017	35
2.7.2.2	The CD 4060	36
Chapter Three: Design and Implementation					37
3.1	Photo-resistive Circuit	37
3.1.1	Design Procedure of Circuit	37
3.1.2	Choice of Components	38
3.1.3	Workings of the Circuit	38

3.2	Ultrasonic Circuit	38
	3.2.1 Design Procedure of the Circuit	39
	3.2.2 Choice of Components	39
	3.2.3 Workings of the Circuit	39
3.3	Timer/Delay Circuit	40
	3.3.1 Design Procedure of Circuit	41
	3.3.2 Choice of Components	41
	3.3.3 Workings of the Circuit	41
3.4	Light Dimmer Circuit	42
	3.4.1 Workings of the Circuit	42
3.5	House Model and Wiring	44
	3.5.1 Design Characteristics	44
	3.5.2 Important Regulatory Considerations	44
Chapter Four: Tests, Results and Discussion								47
4.1	Luminance – Resistivity Test	47
4.2	Findings from Delay Circuit	48
4.3	Findings from Ultrasonic Circuit	49
Chapter Five: Conclusions and Recommendations...								50
5.1	Conclusions	50
5.2	Recommendations	50
References								51
Appendices								53

LIST OF FIGURES

- Fig. 1.1 Block Diagram of the Automation System
- Fig.2.1 Light Sensors in the Human Eye
- Fig. 2.2 Circuit Symbol of a Photocell
- Fig. 2.3 Angle of Incidence
- Fig. 2.4 8-pin V Package
- Fig. 2.5 8-pin T Package
- Fig. 2.6 CD 4017 Showing Pins
- Fig. 2.7 CD 4060 Showing Pins
- Fig. 3.1 Photo-resistive Circuit
- Fig. 3.2 Ultrasonic Pest Repellant Circuit
- Fig. 3.3 Timer/ Delay Circuit
- Fig. 3.4 Light Dimmer Circuit
- Fig. 3.5 Combined Photo-resistive Circuit/Timer Delay Circuit
- Fig. 3.5 Automated House showing mounted photocell
- Fig. 3.6 Diagrammatic representation of IEE Regulation for heights of switches
and sockets etc. [20]

LIST OF TABLES

- Table 2.1 Brightness Values for Different Light Sources
- Table 3.1 Resistor/Voltage Test values
- Table 4.1 Resistor/Voltage Test values

CHAPTER ONE

Introduction

1.1 Project Brief

Busyness is no longer a word to be learnt from the dictionary. Everywhere, and at every time, it is loudly defined in the acts and habits of humanity. Urbanization has further compounded this matter, as we can see the working class leave home almost before sunrise only to return long after sunset. The aged in such community would be at the risk of robbery, armed banditry, and a number of evils too much for their ageing bodies; except quick assistance is offered to them.

One such aid is the Partial Night-Time Home Automation System. It is so called because its basic operations and component composition find effectiveness whenever there is a conspicuous fall in luminous intensity; natural or artificial.

Whereas the Home is the primary target of this project, it may find application and effectiveness wherever an automated system like this is needed.

This project is a system of serially connected circuits consisting of a self-switching lighting system, an ultrasonic pest repellent, and a timer-controlled selective light switch. The Photo-resistive circuit only acts in conjunction with the security light switches as a two-way switch. It does not generate or transmit solar power as may be imagined. A descriptive diagram of the system is shown below. Illumination or darkness falling on the photo-resistive circuit triggers the adjoining subsections off and on respectively.

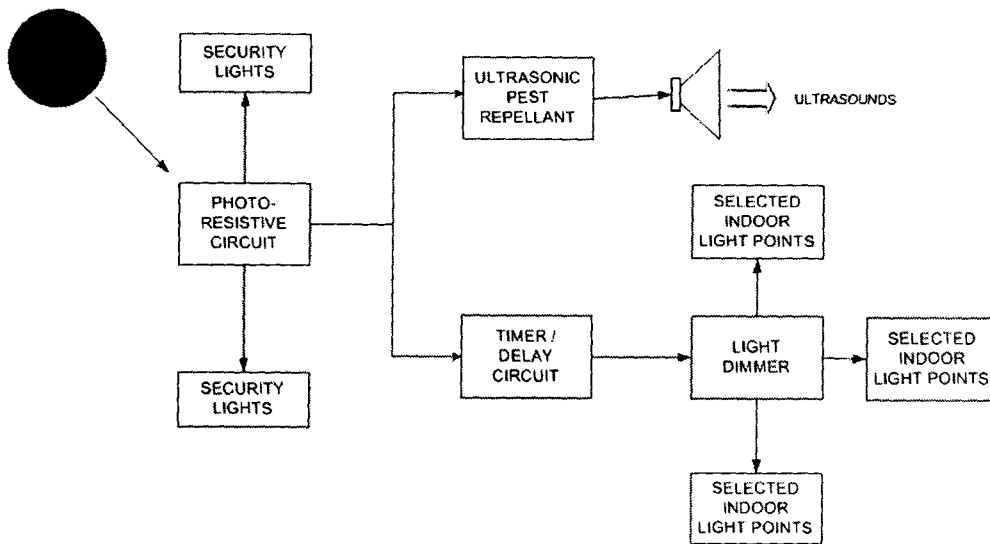

Fig.1.1 Block Diagram of the Automation System

Appropriately, security lights are located outside buildings, and a few are inside (say in banks, or places such as that). This location ensures that the cover of darkness is eliminated sufficiently, so as to deprive hoodlums the much needed condition of operation. In addition, more danger is avoided since illumination is provided to avoid stumbling, falling and or even bites from say snakes, wild dogs or even stepping on nails, broken bottles, other sharp objects or into messy puddles.

All of these could be avoided in the busy urban cities if low-illumination detectors are positioned such that illumination detectors are positioned such that as soon as illumination drops to a particular threshold value, the security lights are automatically triggered on before the arrival of the busy, tired, and late-arriving urban worker. The circuit also switches off as soon as illumination intensity rises to an appreciable value of course above the threshold value.

But aside the switching on, the circuit connects serially to a pest repellent – an ultrasonic pest repellent. Now, it is common knowledge that pests such as mosquitoes, bugs, cockroaches, rodents etc find the night time most conducive for their habits, and more so in urban areas where personal localized hygiene proves grossly insufficient to ward them off; owing of course to the poor waste management, occasioned by population explosion and density; coupled with poor town planning, drainage facilities and sewage disposal systems.

To thus protect one's self and family or household, it becomes imperative to devise another means to keep off these potential disease vectors. The ultrasonic circuit in this system (and project) comes in handy here.

It has been investigated and proven that there is an audible and inaudible part of sound. Below certain decibels (near the 0dB), the human ear will not be able to pick the sound data, not even to mention sending it to the brain for processing. There is also a part in the sound spectrum where we are able to make out what is being produced. This goes on to the point where it becomes too loud, uncomfortable and even harmful ($\approx 130\text{dB}$). On the other extreme is sound that though existent, but unlike the very first cannot be heard by the human ear. In this case there is sound but it goes past the human capacity to detect. This region has been found to be audible to certain creatures, the rodents, mosquitoes, cockroaches and bugs inclusive. However for them, it is not music, it is actually for them what the extreme section of the middle portion of the spectrum is to us – loud, discomforting, threatening and harmful.

Thus, as soon as the lights are turned on, the repellent is spontaneously triggered on as well (being serially connected); and stays so until illumination improves.

The third portion of this system is the selective light-switch circuit. It is also serially connected to the illumination detector.

Unlike the rural areas where everybody is everybody's keeper, urbanization with its enlarged demands takes away conscience from men. As such, it is safer sometimes to have someone stay brief in one's house while away on a journey or a trip that may mean absence from home for a while. But in the urban setting where such a person is not likely to be found, either due to practical non-availability or untrustworthiness, another means must be identified to achieve the end.

The selective light-switch operates alongside the illumination detector such that as soon as both circuits come on, it is also activated. Desired lights such as library lights, toilet/bathroom lights, living room and bedroom lights come on spontaneously and go off at a preset time. This is to give the impression that someone is at home.

For the invalids and aged, or even the busy and tired urban worker, it is a plus, in that he is able to make his way into and around the house with minimal obstruction, and also able to sleep not having to do the rounds of switching on and off lights.

1.2 Objectives of the Project

The goals of this work are to utilize readily available phenomena of light and darkness to provide a relatively affordable means to:

- i. Efficient pest control, thus reducing the health hazard caused by these potential disease vectors.
- ii. Ecological and Environmental-friendly pest control. Rat poisons, insecticides and pesticides have a limit to their usefulness. Aside the environmental unfriendliness in terms of ozone depletion of aerosols, water pollution of pesticides, and the potential danger of self poisoning, there is also the problem of bad smell of animal carcasses and the cost of purchase of these chemical pests and ecological

eradicators. With the ultrasonic repellent, we have a neat, affordable, environmentally friendly, and cheaper and more convenient means of healthy living.

- iii. Security of lives and property in the population dense urban and sub-urban homes
- iv. Reduction in power wastage and hence lesser utility bills and more efficient local power distribution and consumption
- v. Effective and Consistent automatic routine switching of lights and
- vi. Periodic dimming of selected lights.

1.3 Project Methodology

The design, construction/implementation, and testing of this project, the modular approach was utilized, and thereafter the serial arrangement was used. Basically therefore, it was a modular arrangement.

1.4 Scope of Work

Automation of even a square meter apartment could be most consuming in terms of time, mental, financial and other physical resources. Hence, this project seeks to meet the few domestic, and security needs of an urban or sub-urban home: in terms of lighting, as a major consideration, and pest control, and possible eradication.

This project proves very useful to invalids, and aged people living alone, either totally or partially. That is, although such people live with others, these people need to make a living to sustain the household. Or else, such are totally alone as a result of choice or neglect. For such, it is great trouble going about the house switching on and off security lights, and chasing cockroaches, mosquitoes and rats about in an urban city.

1.5 Sources of Materials

Materials needed to realize the design of this project were sourced locally. Every component needed resistors, capacitors, diodes, relays, breadboards, Vero-boards, transformers, transistors, ICs (or their equivalents), photocells, etc were readily available at the local electronics shops.

1.6 Constraints to Optimal Performance

One thing this project takes for granted is that there will always be a constant power supply. Although the initial stage partly utilizes the illumination of the sun, all that ends just there. Every other aspect is based on constant power supply. Thus, in the event of power failure or erratic power condition, the effectiveness of the work will be near zero. However, this is one aspect open to improvement.

1.7 Involvement of Others

The much needed inputs in terms of critique, suggestions and physical hands on job assistance was readily provided by colleagues, lecturers, project supervisor and other, students.

CHAPTER TWO

Literature Review/Theoretical Background

Bearing in mind the scope, aims and objectives of this project, it is expedient that histories and theories surrounding major aspects of the work be appreciated. They are accordingly provided as below.

2.1 The Concept and Principles of Automation

By definition automation is a system in which a workplace or process has been converted to one that replaces or minimizes human labor with mechanical or electronic equipment. In recent times though, this definition has come to include the idea of computerization, in which from a remote location, a house, office, workshop etc, may be monitored and manipulated by the owner(s). Another major metamorphosis to the earlier delineation is robotics. In this case, Electro-mechanical Engineers build “metallic” or “plastic” human similitude, very often equipped with some degree of artificial intelligence.

2.2 A Brief History of Automation

As earlier noted, automation has come to be associated with computerization and robotics. The word ‘robot’ is an invention of fiction. It was coined from the Czech word ‘*robotnik*’, meaning a slave or a serf and used by Karel Capek in his play R.U.R produced in 1920. R.U.R stood for Rossum’s Universal Robots which were the subject of the play – mechanical machines modeled on the lines of human beings with an immense capacity for work...It is safe to think that robots...has its roots in ancient times when attempts were made to build automata – human like devices, moving figurines, mechanical

servants, and the like...Statutes of gods with moving hands and heads were known in Ancient Egypt, Babilon and China. [1]

There are many automatic control systems in general everyday use, but most of the sophisticated Control Systems are to be found in industrial applications. These applications are often referred to as automation...There are many advantages to be found in automation...we can think of advantages as being:

- i. Consistent production
- ii. Release of production operators for more useful work
- iii. Improved condition for the operators

If the work is more complex, other advantages would include:

- iv. Improved accuracy of manufacture
- v. Economic use of expensive plant [2]

2.3 Home Automation

One remarkable change in this century is the way science and technology is beginning to make it possible to control the basic elements of the physical environment...advances are reshaping our perception of our selves and our surroundings. The world now seems to have been reduced in size and a collective humanity seems to have grown larger in comparison... These developments are epitomized by the emerging industry of home automation, which provides an example of our newfound ability to surround ourselves with an environment under our control. People who live in automated or "smart" houses can manipulate their dwelling space from a computer terminal. They can monitor or alter the status of lights, temperature, locks and other functions by typing in commands. They can control future events by setting certain features such as a radio or

stove, to go on and off at predetermined times. And they can look into different parts of the house with video cameras that feed pictures to television screens.

In effect, the occupants of smart houses become sovereigns over their living space and they begin to think of the house as a kind of technology slave. The computer terminal, which can be as portable as a remote control or as ubiquitous as a converted telephone keypad, becomes a magic wand, allowing them to manipulate events that are separated from them in time and space. The computerized house becomes a giant Clapper: both an ever-compliant companion and an extension of the occupant, expanding the ability to act, sense and think...Albert Einstein minimized his wardrobe to avoid wasting time thinking about what to wear. Simplifying his life gave him more time and energy to focus on his work. Home automation works the same way. It simplifies your life by shifting the more mundane and tedious tasks from you to your home. With a 'smarter' home, you can focus more of your time and energy on the people and things that matter most to you.

Nearly Thirty years ago, there was only one technology for home automation (X-10) and a very limited number of companies who made devices for this 'defacto' standard. Today, newer technologies (like Z-Wave and Insteon) have joined X-10 and there is a bewildering array of devices for the home owner to choose from". [3]

The pace of Automation technology is such that you could own a personal butler, a valet and a concierge all in one - at your beck and call. "The reality is you may be able to purchase one in the form of an automated technology system for your home. The system, known as Ralph, is a voice-commanded control, monitoring and supervisory system. It uses voice recognition to take commands from the home's occupants and talks back to them with speech synthesis. For those who prefer not to use the voice command system, a pushbutton control is available. Ralph helps people live independently in their

own homes by doing small things they cannot do for themselves. The system was originally developed to help Don Holbert. Don, who is paralyzed below the waist...." [4] Originally designed to be a home assistant for the physically disabled, R.A.L.P.H. (Real Assisted Living for the Physically Handicapped) has evolved into the home assistant for everyone! Ralph operates as an environmental control unit (ECU), motion monitoring alert system, call for help device and personal virtual companion. The goal of R.A.L.P.H. is to empower people with special needs through independent living and semi-assisted living. [5]

However, as laudable as these advances are, it hardly fits into the Nigerian or African context. No doubt a few rich personalities may be able to afford such technologies; the generality of masses will be left standing and only wishfully thinking. Besides the relatively high cost, the technical expertise to maintain these gadgets are unavailable, not to talk about its inconsistency with the African tradition of strong interpersonal relationships. This is the grounds that necessitate this project which apart from being far cheaper, is easier to design, fabricate, use, and maintain – while upholding the African culture in better esteem.

2.4 Sound

It is essential to understand the phenomenon of sound vis-à-vis its production, propagation, and perception – in relation to man and animals.

“The mechanism by which sound waves are converted into a perception by the brain is extremely complicated and parts of it are not fully understood” [6]

Sound in simple terms is something that can be heard. Here reference is indirectly made to the human or animal sense of hearing. More technically (bio-technologically), it

is vibration of air caused by collision of bodies or other means, sufficient to affect the auditory nerves when perfect. Some persons are so entirely deaf that they cannot hear the loudest sounds. Audible sounds are such as are perceptible by the organs of hearing. Sounds not audible to men may be audible to animals of more sensible organs.

Very technically, sound is a disturbance of mechanical energy that propagates through matter as a wave. Sound is characterized by the properties of sound waves which are frequency, wavelength, period, amplitude and velocity or speed.

Noise and sound often mean the same thing; when they differ, a noise is an unwanted sound. In science and engineering, noise is an undesirable component that obscures a signal.

Humans perceive sound by the sense of hearing. By sound, we commonly mean the vibrations that travel through air and can be heard by humans. However, scientists and engineers use a wider definition of sound that includes low and high frequency vibrations in air that cannot be heard by humans, and vibrations that travel through all forms of matter, gases, liquids and solids. The matter that supports the sound is called the medium. Sound propagates as waves of alternating pressure, causing local regions of compression and rarefaction. Particles in the medium are displaced by the wave and oscillate. The scientific study of sound is called acoustics. [7]

2.4.1 Ultrasonic: History and Principle

Prior to World War II, sonar, the technique of sending sound waves through water and observing the returning echoes to characterize submerged objects, inspired early ultrasound investigators to explore ways to apply the concept to medical diagnosis. In 1929 and 1935, Sokolov studied the use of ultrasonic waves in detecting metal objects. Mulhauser, in 1931, obtained a patent for using ultrasonic waves, using two transducers

to detect flaws in solids. Firestone (1940) and Simons (1945) developed pulsed ultrasonic testing using a pulse-echo technique.

Shortly after the close of World War II, researchers in Japan began to explore medical diagnostic capabilities of ultrasound. The first ultrasonic instruments used an A-mode presentation with blips on an oscilloscope screen. That was followed by a B-mode presentation with a two dimensional, gray scale imaging.

Japan's work in ultrasound was relatively unknown in the United States and Europe until the 1950s. Then researchers presented their findings on the use of ultrasound to detect gallstones, breast masses, and tumors to the international medical community. Japan was also the first country to apply Doppler ultrasound, an application of ultrasound that detects internal moving objects such as blood coursing through the heart for cardiovascular investigation.”[8]

The term "ultrasonic" applied to sound refers to anything above the frequencies of audible sound, and nominally includes anything over 20,000 Hz. Frequencies used for medical diagnostic ultrasound scans extend to 10 MHz and beyond.

Sounds in the range 20-100 kHz are commonly used for communication and navigation by bats, dolphins, and some other species. Much higher frequencies, in the range 1-20 MHz, are used for medical ultrasound. Such sounds are produced by ultrasonic transducers. A wide variety of medical diagnostic applications use both the echo time and the Doppler shift of the reflected sounds to measure the distance to internal organs and structures and the speed of movement of those structures. Typical is the echocardiogram, in which a moving image of the heart's action is produced in video form with false colors to indicate the speed and direction of blood flow and heart valve movements

Ultrasonic sound can be produced by transducers which operate either by the piezoelectric effect or the magnetostrictive effect. The magnetostrictive transducers can be used to produce high intensity ultrasonic sound in the 20-40 kHz range for ultrasonic cleaning and other mechanical applications.

2.4.1.1 Application of Ultrasonic

On the whole, medical and Para-medical sciences have found ultrasonic rather useful in many more areas than other fields. For example,

i. Medical sonography (ultrasonography) is a useful ultrasound-based diagnostic medical imaging technique used to visualize:

- muscles, tendons, and many internal organs, their size, structure and any pathological lesions

- A fetus during pregnancy.

Ultrasound scans are performed by medical health care professionals called sonographers.

ii. Obstetric sonography is commonly used during pregnancy.

iii. Treating benign and malignant tumors and other disorders, via a process known as Focused Ultrasound Surgery (FUS) or HIFU, High Intensity Focused Ultrasound. These procedures generally use lower frequencies than medical diagnostic ultrasound (from 250 kHz to 2000 kHz), but significantly higher time-averaged intensities. The treatment is often guided by MRI, as in Magnetic Resonance guided Focused Ultrasound.

iv. More powerful ultrasound sources may be used to clean teeth in dental hygiene or generate local heating in biological tissue, e.g. in occupational therapy, physical therapy and cancer treatment.

- v. Extracorporeal shock wave lithotripsy uses a powerful focused ultrasound source to break up kidney stones.
- vi. Focused ultrasound sources may be used for cataract treatment by phacoemulsification.
- vii. Physiological effects of low-intensity ultrasound have recently been discovered, e.g. the ability to stimulate bone-growth and its potential to disrupt the blood-brain barrier for drug delivery.
- viii. Ultrasound is used in UAL (= ultrasound-assisted lipectomy), or liposuction.
- ix. Doppler ultrasound is being tested for use in aiding tissue plasminogen activator treatment in stroke sufferers. This procedure is called Ultrasound-Enhanced Systemic Thrombolysis.
- x. Low intensity pulsed ultrasound is used for therapeutic tooth and bone regeneration.
- xi. Ultrasound can also be used for elastography: This can be useful in medical diagnoses, as elasticity can discern healthy from unhealthy tissue for specific organs/growths. In some cases unhealthy tissue may have a lower system Q, meaning that the system acts more like a large heavy spring as compared to higher system Qs (healthy tissue) that respond to higher forcing frequencies. Ultrasonic elastography is different from conventional ultrasound, as both a transceiver (pair) and transmitter are used instead of one transceiver.

Other Applications

Aside the medics, other disciplines have also found ultrasonic useful. Take for example,

- xii. Industrial ultrasound: Ultrasound is also used in industry to find flaws in materials.
- xiii. Ultrasound flow meter.
- xiv. Ultrasonic cleaning of jewelry, watches, dental instruments, surgical instruments, industrial parts, lenses and other optical parts using frequencies from 20-40 kHz.

xv. Ultrasonic disintegration of biological cells and bacteria, for sewage treatment, and research works in biological sciences.

xvi. Ultrasound as weapon-Sonic weaponry.

2.4.1.2 Effects of Ultrasonic

As enumerated above, medical sciences as well as other fields have found ultrasounds very useful in several applications. However, there are insinuations of adverse effects of the same in some quarters; for example De Deyne PG, and Kirsch-Volders M of the Department of Physical Therapy, University of Maryland at Baltimore 21201, USA performed an experiment to examine the cytological effects of therapeutic ultrasound on human fibroblasts. Using an in vitro approach, the number of cells recovered, the morphology of chromosomes, and the presence of mitotic spindles were studied after sonication of human fibroblasts in culture. The ultrasound output had a frequency of 1 MHz and was delivered in a pulse mode of 2 milliseconds "on" and 8 milliseconds "off." Sonication was given for 0, 30, 60, and 90 seconds...There was a time-dependent decrease in number of cells recovered, a fourfold increase in mitotic index in the cells that survived the treatment, and a nearly eightfold increase of chromosomal aberrations with loss of mitotic spindles...The dose-dependent lytic effect of nonthermal ultrasound could result in fractionation of cells, which might facilitate phagocytosis during chronic inflammation. ...increase in chromosomal aberrations and a loss of mitotic spindles as a result of an extremely short ultrasound treatment (30 seconds). Whether these alterations are mutagenic or not warrants further study. It is possible that in our in vitro experiments, the ultrasound received was greater than would occur in a clinical situation. [9]

A report also has it that, the pitch used is well within the range that most children can hear, and can cause headaches. There are claims and counter claims; more like the issue of the harmful effect of the mobile phone on its user.

2.4.2 History and Principles of Pest Repellants

By the very definition of the word 'pest' (a damaging organism; annoying person or thing; or an outbreak of disease), discomfort is awakened. The fight against these nuisances is as old as man. As a result man has continually devised and fashioned various schemes to either control, or entirely eliminate this unwanted visitors. Ancient men went the crude way of physically running after farm pest to ward them off, to making scare-crows (a make-believe harmless human). Technology has since advanced, though essentially on the same principles. The underlying rule in pest control is to use whatever means safe to man, with minimal need for precautions, and great danger to the pests themselves – even to the point of death.

2.4.2.1 Effectiveness and Limitations of Pest Repellants

Before the late 1930s, there were few effective ways of dealing with damaging or dangerous insects. A major breakthrough came in 1939, with the discovery that a synthetic compound called DDT was lethal to insects. By the end of World War II, DDT was in use worldwide, and other synthetic insecticides soon followed. But by the 1970s it became clear that some of these chemicals could cause lasting environmental damage because they are harmful to many other animals in addition to insects...

In recent decades, insects have also been turned on each other. Known as biological control, this method often involves using predatory or parasitic insects to kill insect pests. In another form of biological control, sterilized males are raised in captivity

and then released. The sterile males mate with wild females, and although the females lay eggs, the unfertilized eggs fail to develop.

Biological control is safe for humans, but compared to insecticides, its effectiveness can be hard to predict. For this reason, many harmful insects are now dealt with by a mix of chemical and biological means. Known as integrated pest management (IPM), this system minimizes harm to the environment while keeping problem insects in check. [10]

2.5 Vision and Illumination

Two important concepts to understand in order to appreciate this project are Vision and Illumination. This is very much so because, being a night time device, the associated parameters of human vision vis-à-vis the darkness must be given diligent attention.

2.5.1 Illumination

The usual method of producing artificial light consists of raising a solid body or vapor to incandescence by applying heat to it. It is found that as a body is gradually heated above room temperature, it begins to radiate energy in the surrounding medium...
...a certain temperature is reached, light waves are also radiated out in addition to heat waves and the body becomes luminous....the color of light or visible radiation changes from bright red to orange, to yellow and then finally, if the temperature is high enough to white...As the temperature is increased beyond that at which light waves were first given off, the radiant efficiency increases... [11]

Light is that part of the spectrum of electromagnetic radiation that the human eye can see. It lies between about 400 and 700 nanometers. All the units for measuring and defining light are based on the candela, which is the unit defining the luminous intensity from a small source, in a particular direction. This unit was originally based on the light emission from a flame.

The standard later came to be defined as the glow from molten platinum. The current definition is a radical departure from the previous formulations; because it defines light intensity in terms of the unit for radiated power in general, the watt (W), or joule per second(J/s). The candela is therefore no longer strictly necessary as a fundamental unit, because it is now defined in terms of a fundamental SI unit.

Besides differing in color (frequency), light can also differ in luminosity, or brightness. A table lamp emits less light than a halogen lamp, but even a halogen source cannot be compared with bright sunlight, as far as luminosity is concerned. Luminosity depends on the amount of available light. Luminosity is the basic principle of the black-and-white television. All shades between black and white can be created by adjusting the luminosity to specific values.

It can be measured and recorded in a numeric value. In the past, it was expressed in Hefner Candlepower, but nowadays Lux is used to express the amount of luminosity. Below are some brightness values for different light sources:

Table 2.1: Brightness Values for Different Light Sources

LIGHT SOURCE	BRIGHTNESS VALUE (Lux)
Candle light at 20 cm	10-15
Street light	10-20
Normal living room lighting	100
Office fluorescent light	300-500
Halogen lamp	750
Sunlight, 1 hour before sunset	1000
Daylight, cloudy sky	5000
Daylight, clear sky	10,000
Bright sunlight	> 20,000

2.5.1.1 Definitions of Terms

The **candela** is the luminous intensity, in a given direction, of a source that emits monochromatic radiation of frequency 540×10^{12} hertz and that has a radiant intensity in that direction of $1/683$ watt per steradian...

The frequency chosen is that to which the eye is most sensitive. This frequency is normally referred to as the corresponding wavelength: 555 nanometer. The wavelength varies with the medium through which the light passes, so, in the interest of precision, our relatively familiar wavelength description of light is not used in the standard.

The **steradian** is the cone of light spreading out from the source which would illuminate one square meter of the inner surface of a sphere of 1 m radius around the source. Luminous emission is not the same as the perceived brightness of the source when you look at it. The definition implies a small source, because the energy stream from it is defined as energy within a given solid angle, independent of distance to the measuring instrument. If the source is very small, a tiny quartz halogen torch bulb for example, the

brightness will appear to be intense even if its emission is one candela. If the source is, like a candle, small but not really a point, you will get an impression of a small area of light of moderate brightness, even though the light intensity is also one candela. The apparent brightness of a source when you look directly at it must not be confused with its luminous emission. The brightness of a source is measured in candela per square meter. Everything that is visible can be regarded as a light source. [12]

2.5.2 Principles of Human Vision

We must go to the Medicals or at least paramedics to safely understand this theory. The human sight sense is probably the most complex and delicate in the entire body. It may thus be only rightly anticipated as difficult to explain or understand. It is not so perplexing.

When light enters the eye, it first passes through the cornea, then the aqueous humor, lens and vitreous humor. Ultimately it reaches the retina, which is the light-sensing structure of the eye. The retina contains two types of cells, called rods and cones... Below is an example of a rod and a cone:

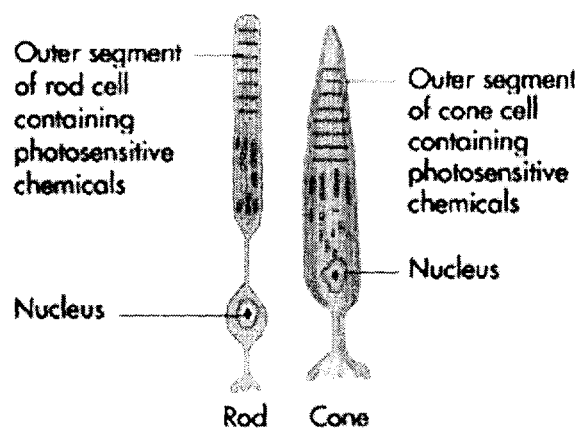

Fig.2.1 Light Sensors in the Human Eye

The outer segment of a rod or a cone contains the photosensitive chemicals. [22]

2.5.3 Light Dimmers: Principles of Operation

Light dimming is based on adjusting the voltage which gets to the lamp. Light dimming has been possible for many decades by using adjustable power resistors and adjustable transformers. Those methods have been used in movie theatres, stages and other public places. The problem of those light controlling methods have been that they are big, expensive, have poor efficiency and they are hard to control from remote location.

The power electronics have proceeded quickly since 1960. Between 1960-1970 thyristors and TRIACs came to market. Using those components it was quite easy to make small and inexpensive light dimmers which have good efficiency. Electronics controlling also made possible to make them easily controllable from remote location...and are nowadays used in very many locations like homes, restaurants, conference rooms and in stage lighting.

Solid-state light dimmers work by varying the "duty cycle" (on/off time) of the full AC voltage that is applied to the lights being controlled. For example, if the voltage is applied for only half of each AC cycle, the light bulb will appear to be much less bright than when it get the full AC voltage, because it gets less power to heat the filament. Solid-state dimmers use the brightness knob setting to determine at what point in each voltage cycle to switch the light on and off.

Typical light dimmers are built using thyristors and the exact time when the thyristor is triggered relative to the zero crossings of the AC power is used to determine the power level. When the thyristor is triggered it keeps conducting until the current passing though it goes to zero (exactly at the next zero crossing if the load is purely resistive, like light bulb). By changing the phase at which you trigger the TRIAC you change the duty cycle and therefore the brightness of the light. [14]

Common light dimmers have a throbbing action. They allow current through for a fraction of each cycle (of 60 Hz), and then they stop the current for the remainder of the cycle.

2.5.3.1 DIACs and TRIACs

DIACs are two terminal devices containing bidirectional diodes that will not conduct until the voltage across them reaches a predetermined value known as the breakdown voltage. They are usually used as capacitor discharge devices

A TRIAC is another electronic switching device, but unlike the thyristor, which gives only half-wave control, the TRIAC can be turned on during the positive or negative half cycles. [15]

2.6 History and Theory of Photocells

A photocell, also known as a Light Dependent Resistor, (LDR for short) is an input transducer (sensor) which converts brightness (light) to resistance. It is made from cadmium sulphide (CdS) and the resistance decreases as the brightness of light falling on the LDR increases. A photocell is kind of diode that is specialized to turn light into separated electrical charge. When light hits the "n-type" side of this diode, it adds energy to the valence level electrons there and moves them to the empty conduction levels. These electrons may even have enough energy to leap across the p-n junction into the "p-type" material. Once they get there, they cannot return because of the depletion region and the one-way effect of the diode. Instead, they are collected by wires attached to the "p-type" material, flow out through some electrical circuit, and return to the "n-type" material through another set of wires.

A multimeter can be used to find the resistance in darkness and bright light; these are the typical results for a standard LDR:

Darkness: maximum resistance, about $1\text{M}\Omega$.

Very bright light: minimum resistance, about 100Ω .

For many years the standard LDR has been the ORP12, now the NORPS12, which is about 13mm diameter. Miniature LDRs are also available and their diameter is about 5mm. An LDR may be connected either way round and no special precautions are required when soldering.

2.6.1 Photocells and Light Detection

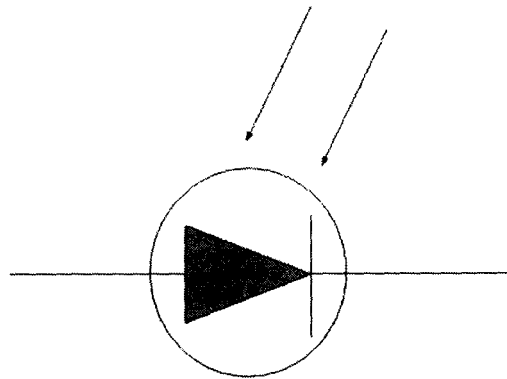

Fig. 2.2 Circuit Symbol of a Photocell

It works due to the photo-electric effect: the conversion of an EM-wave (light) into an electric current. It is this phenomenon that Einstein explained in terms of quantized energy (of the target atoms of the electrode, NOT the EM-wave). It also suggested for the first time that EM-waves could be seen as a stream of particles called photons. This effect did NOT prove the particle-behavior of waves, it just suggests it.

2.6.1.1 How Photocells Absorb Light And Turn It into Power

The incident light on the photocell knocks loose conduction electrons from the target electrode. This electron will have enough energy to move to the surface of the electrode and it will then be 'ejected from' that electrode, yielding an electric current. The conduction electrons are bound to the constituting atoms of the electrode with less energy, so it is easier to knock them loose.

These electrons are the valence (i.e. the outer electrons) electrons of the constituting atoms. When put together, the wave functions of atoms (more specifically, their orbital) will overlap and this yields a 'continuous' region over the atom-lattice, which can be occupied by these electrons. They are not localized to one atom but they can move 'freely' over the entire atomic-lattice.

When a photocell is exposed to light, some of the light particles (photons) are absorbed in the diode's cathode layer. When such absorption occurs, the photon's energy may be transferred to an electron in the cathode, giving that electron the energy it needs to cross the depletion region and reach the anode. But once the electron has arrived at the anode it can't return to the cathode directly across the depletion region. Instead, it must flow through an external circuit in order to return to the cathode. As that electron flows through the external circuit, it can give up some of its energy, obtained from the light photon, to devices in that circuit. In that manner, light energy has provided energy to an electrically powered device.

If photocells lose electrons in the process of use, it may be reasoned that they get old or used up from too much light knocking off their electrons. Another way of thinking could be thus: because photocells lose more and more electrons the longer they are used, they get more positively charged the longer they are in use.

The semiconductor is usually grounded, meaning it is being replenished with electrons that either were photo emitted, or the ones that got "conducted" away. If not, there will be charging effects on the cell and it will stop functioning, because the effective work function will just build up due to charge depletion. If it is not perfectly grounded, it is entirely possible for a photo-cell to be saturated, especially if done continuously.

Either way, most manufacturers will indicate the working range of any photocell. And this is not just with respect to power, but also what frequency, range, temperature, etc...

Since not all of the light power absorbed by a photocell is converted into electric power, a photocell that is exposed to too much light will overheat. High temperatures are disastrous for all semiconductor devices, photocells. If a semiconductor device overheats slightly, the excessive thermal energy will change the electronic properties of the semiconductor layers such that these layers will not behave as they were chemically designed to operate. In an overheated photocell, charge will be allowed to flow backward so that the photocell will become less energy efficient. But if a semiconductor device overheats seriously, the semiconductor layers will change permanently--atoms, molecules, and entire structures will migrate and rearrange, and the device will never work properly again.

By itself, an overheated photocell will not fail dramatically; it will just stop working. If overheated severely, it will remain broken from then on. But if the photocell is part of a larger collection of power generating elements that continues to produce power, that photocell may suddenly consume all of the power from the other elements. In that case, the photocell may explode as its temperature rises steeply.

Proper setup and installation of photocells (or light sensors) ensures proper operation. It is important to understand some general principles of lighting before any

process of set up and installation is performed. These general principles illustrate why photocells have to be setup and installed in a specific way.

2.6.2 Positioning of Photocells

The ideal location for placing photocells is:

- A location where direct light dominates total incident light. Generally, this means the photocell is mounted high, and away from the floor.
- A location where the DIZ and ISZ are as small as possible and where they do not overlap significantly with neighboring trees and high-rise building. Generally, this means the photocell is mounted high, and away from interfering objects.
- A location where the distances between the photocell and all of the sources of light (including the sun) the same, or more exactly, a location where the light emitted from each light source contributes equally to the total amount of light detected by the photocell. This minimizes the possibility of any one fixture dominating the direct light total.

2.6.2.1 Location Parameters of Photocells

Some cardinal Parameters related to this include:

1. Direct Light and Indirect Light: The light that can be detected by a photocell is composed of two main components: direct light and indirect (or reflected) light.

- The Direct Interference Zone (DIZ): The space in a room where there may be objects that can affect the amount of direct light detected is known as the Direct Interference Zone (DIZ). Direct Light Additional objects in a room can cast shadows,

which can decrease the amount of direct light that is detected by the photocell. As the angle of incidence increases, the size of the DIZ also increases, and it becomes increasingly likely that other objects in the room will decrease the amount of direct light detected by the photocell.

- Indirect Lighting is Primarily Affected by Room Characteristics because most indirect light is effectively diffused (that is, indirect light comes from all directions and not a point source), the angle of incidence to the direct source has a much smaller impact on indirect light. With indirect lighting, the characteristics of a room have a greater effect on the amount of indirect light detected than the angle of incidence does. Room characteristics include the room's size, the reflectivity of the room's surfaces, the characteristics and placement of room contents, and the location and number of light sources.

- Indirect Sensitivity Zone (ISZ): The space in a room where other objects can affect the amount of indirect light detected is known as the Indirect Sensitivity Zone (ISZ). As a light sensor is lowered, the ISZ increases. This means the amount of indirect light received can fluctuate wildly, based on changing room conditions and occupants. The Effect of the Position of the Photocell on Light Detection In a typical room, the amount of indirect light detected at the photocell can be 20-40% of the total incident light detected. As a photocell is lowered (positioned closer to the floor) the amount of indirect light detected at the photocell can exceed 50% of the total incident light detected.

2. **Angle of Incidence:** The angle of incidence can be defined as the angle that a line (as a ray of light) falling on a surface or interface makes with a line drawn perpendicular to the point of incidence. The angle of incidence is illustrated in Fig.4 below

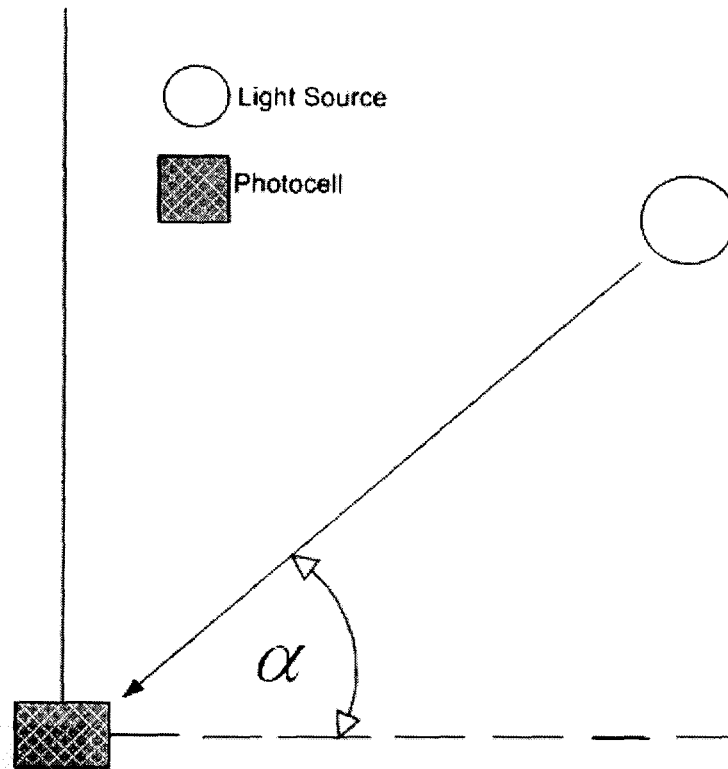

Fig. 2.3 Angle of Inclination

As the angle is increased, the amount of direct light detected is decreased. The Angle of Incidence Affects the Amount of Direct Light Detected As the angle of incidence from the light source to the photocell increases, the amount of direct light detected at the photocell decreases. The amount of direct light detected by the photocell will decrease at a rate that is equal to the cube of the cosine of the angle of incidence.

That is mathematically,

$$S \propto \frac{1}{(\cos \alpha)^3} \quad -1$$

Where S= amount of direct sunlight; and α = angle of incidence of light

As the source of most of the light in a room comes from the ceiling, the angle of incidence is increased when a photocell is mounted close to the ground. The angle of incidence is decreased when the photocell is mounted high, away from the ground. Where the photocell is placed affects direct light intensity. More direct light is detected when the photocell is positioned high above the floor. As the photocell is positioned lower, closer to the floor, the angle of incidence is increased and the amount of direct light detected is decreased.

As the mounting location for the photocell is lowered, the following negative consequences occur:

1. The amount of direct light decreases more rapidly than the amount of indirect light, making the amount of indirect light a larger percentage of the total light detected.
2. The DIZ increases.
3. The ISZ increases.

The result is detected light levels will vary widely based on ecological or, and changing social and architectural habits, say building of skyscrapers where only bungalows once existed.

Under these conditions, accurate "on" versus "off" thresholds are difficult to set and false "off" conditions may be detected. The house will also require frequent calibration.

2.6.2.2 Consequences of Poor Positioning

Some examples of poor locations for the placement of photocells include:

- Locations too close to the floor (within 6 feet of the floor).
- Locations too close to corners (within 3 to 6 feet of a corner).
- Locations where there are obstructions between the light source and the photocell.

These obstructions do not always have to be permanent obstructions – for instance, if a photocell is mounted behind a door, the door is not an obstruction when the door is closed, but the door becomes an obstruction when it is opened.

- Locations where the photocell is too close to one light source and that one source makes up a large proportion of the total light detected by the photocell.

When photocells are mounted in poor locations,

- The placement and movement of furniture, pieces of equipment and people can simultaneously produce up to a 40% decrease in direct light, along with
- An unspecified decrease in indirect light. Though not discernable by the human eye, it is not unreasonable for there to be a 50% reduction in the light detected by the photocell in these rooms. This has a significant effect on the calibration system to accurately monitor the illumination.

2.7 Evolution of IC Technology

The manufacture of transistors is achieved by a process that makes many transistors on a single slice, which is then cut to form the individual transistors. Although not simple to effect, it was a logical development to keep the transistors together on the slice. From this development was evolved the integrated circuit, often referred to as an IC... [2]

In 1958, J.S. Kilby developed an “integrated circuit”, a single monolithic chip of semiconductor in which active and passive circuit elements were fabricated by successive diffusions and depositions. Shortly thereafter, Robert Noyce fabricated a complete circuit including the interconnections on a single chip...Typically, an IC might compose 20 – 30 transistors with possibly 50 – 100 other passive components such as resistors all in the volume formerly taken up by a single bipolar transistor”[16,2]

Other types of integrated circuits, known as thin-film and thick-film circuits are also available; with both...resistors and capacitors are fabricated by forming a suitable film on to the surface of a glass or a ceramic substrate. The components are interconnected in the required manner by means of a deposited metallic pattern...

The fabrication of an integrated circuit component is achieved by a sequential series of oxidizing, etching and diffusion” [15]

2.7.1 History and Operational Principles of Timers

Timers define a limit to the amount of time required for a specific operation to complete. When the timer begins its countdown depends on type of operation it controls [17]

2.7.1.1 The 555 Timer

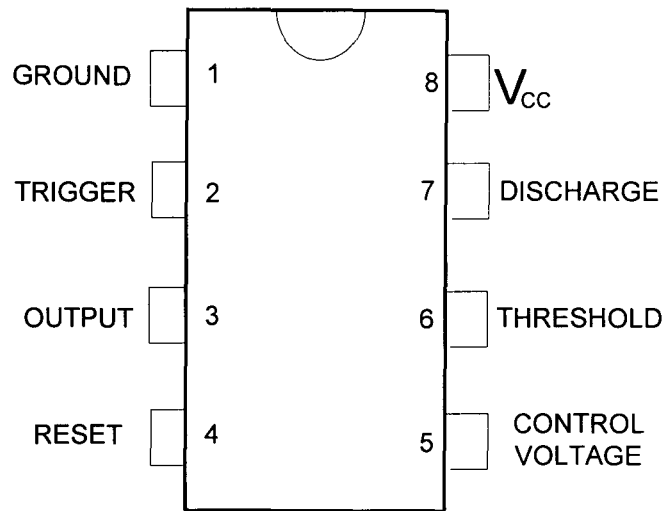

Fig. 2.4 8-pin V Package

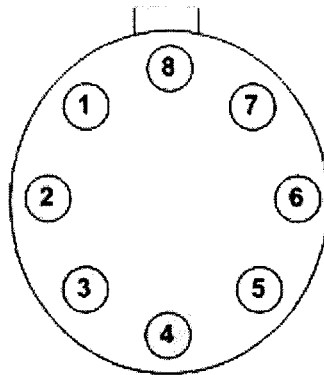

Fig. 2.5 8-pin T Package

The 555 timer IC was first introduced around 1971 by the Signetics Corporation as the SE555/NE555 and was called "The IC Time Machine" and was also the very first and only commercial timer IC available. It provided circuit designers and hobby tinkerers with a relatively cheap, stable, and user-friendly integrated circuit for both monostable and astable applications. Since this device was first made commercially available, a myriad of novel and unique circuits have been developed and presented in several trade, professional, and hobby publications. The past ten years some manufacturers stopped

making these timers because of competition or other reasons. Yet other companies, like NTE (a subdivision of Philips) picked up where some left off.

This primer is about this fantastic timer which is after 30 years still very popular and used in many schematics. Although these days the CMOS version of this IC, like the Motorola MC1455, is mostly used, the regular type is still available; however there have been many improvements and variations in the circuitry. But all types are pin-for-pin plug compatible... [13]

When the 555 Timer is in the astable mode of operation, “the unit is connected so that it triggers itself, and as a result, the output oscillates continually.” [12]

The charging time of the external capacitor is given by:

$$t_1 = 0.695 (R_A + R_B) C \quad -2$$

The Discharge time or Output low is given by:

$$t_2 = 0.695 R_B C \quad -3$$

While the total time period T, and the Duty Cycle (the ratio of the time when the output is low to the total Period), are given by the following equations respectively:

$$T = t_1 + t_2 = 0.695 (R_A + R_B) C \quad -4$$

$$DC = R_A / (R_A + 2R_B) \quad -5$$

With this particular set of definitions, the duty cycle cannot be more than 50% and the OFF TIME must be less than the ON TIME.

2.7.2 The “4000” Series

The 4000 series is the general classification used to refer to the industry standard integrated circuits which implement a variety of logic functions using CMOS technology. They were introduced by RCA as CD4000 COS/MOS in 1968, as a lower power and more versatile alternative to the 7400 series of TTL logic chips. Almost all IC manufacturers active during the era fabricated chips from this series... (See Appendix A)

Initially, the 4000 series was slower than the popular 7400 TTL chips, but had the advantage of much lower power consumption, the ability to operate over a much wider range of supply voltages (3V to 15V), and simpler circuit design due to the vastly increased fanout. However their slower speed (initially only capable of about 1 MHz operation, compared with TTL's 10 MHz) meant that their applications were limited to static or slow speed designs. Later, new fabrication technology largely overcame the speed problems, while retaining backward compatibility with most circuit designs. Although all semiconductors can be damaged by electrostatic discharge, the high impedance of CMOS inputs made them more susceptible than bipolar, TTL, devices. Eventually, the advantages of CMOS (especially the later series such as 74HC) edged out the older TTL chips, but at the same time ever increasing LSI techniques edged out the modular chip approach to design. The 4000 series is still widely available, but perhaps less important than it was two decades ago.

The series was extended in the late 1970s and 1980s to include new types which implemented new or more greatly integrated functions, or were better versions of existing chips in the 4000 series. Most of these newer chips were given 45xx and 45xxx designations, but are usually still regarded by engineers as part of the 4000 series.

In the 1990s, some manufacturers (e.g. Texas Instruments) ported the 4000 series to their 74HC / 74HCT series to make chips like the 74HCT4060 that offers the functionality of a 4060 IC but with the speed of the 74HCT chip. [18]

2.7.2.1 The CD 4017

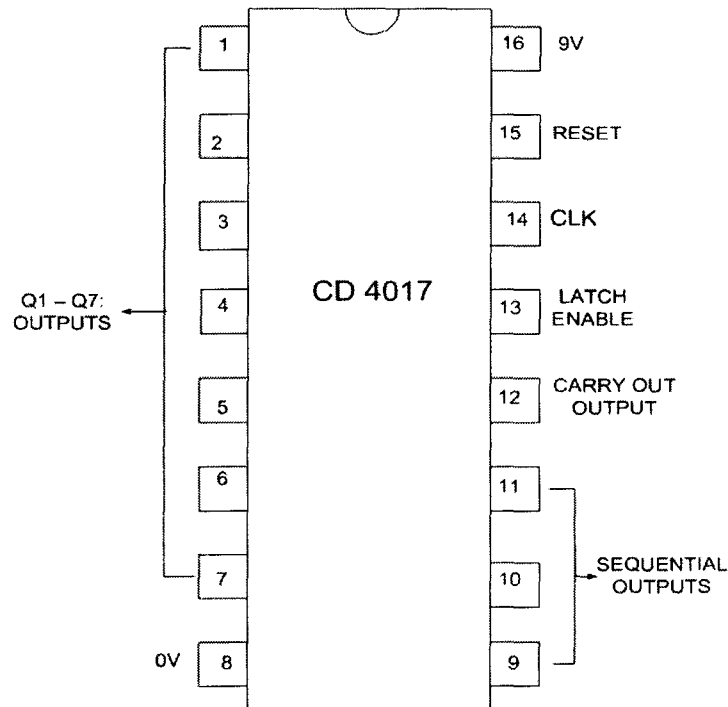

Fig. 2.6 CD 4017 Showing Pins

The 4017 IC is a 16-pin CMOS decade counter from the 4000 series. It takes clock pulses from the clock input, and makes the ten outputs come on in sequence every time a clock pulse arrives. . [18]

2.7.2.2 The CD 4060

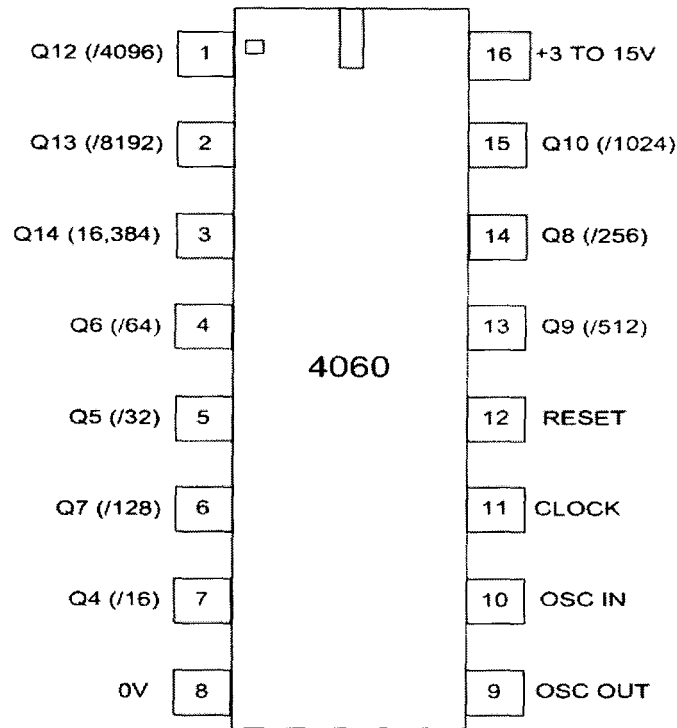

Fig. 2.7 CD 4060 Showing Pins

The '4060' is a 14-stage CMOS binary counter (14 cascaded flip-flops). A rising edge at the input brings Q HIGH, enabling the counter. After 2^{n-1} clock pulses, Q_n clears the flip-flop and the counter. This circuit generates an accurate long pulse whose length may be varied by factors of 2. The '4060' also includes internal oscillator circuitry that can substitute for the external clock reference...the internal oscillator has poor frequency tolerance and (in some HC versions) may malfunction..." [19]

CHAPTER THREE

Design and Implementation

3.1 Photo-resistive Circuit

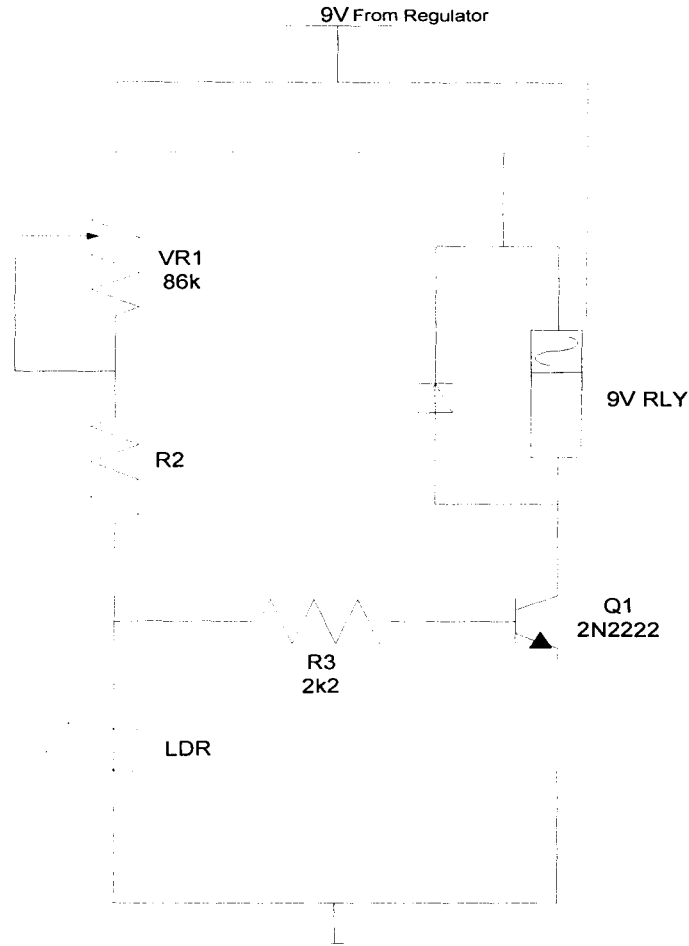

Fig. 3.1 Photo-resistive Circuit

3.1.1 Design Procedure of Circuit

The circuit as shown above consists of a photocell, (or LDR), a transistor, a relay, and resistors ($VR1=86k\ \Omega$, $R2=470\ \Omega$ and $R3=2.2k\ \Omega$). Prior to the final and permanent placement onto the Veroboard, the circuit was mounted to a breadboard, and tested for efficiency and functionality. Subsequently, it was simulated on software (Multisim to be precise). Verification of the resistance values as well as transistor polarities were carefully confirmed before soldering.

3.1.2 Choice of Components

Every component was chosen with the understanding of a circuit. The relay was particularly chosen with the consideration that it will trip the adjoining circuit.

3.1.3 Workings of the Circuit

Fall in illumination, decreases the resistance of the photocell until the base voltage into the transistor approaches 0.6V. At this voltage, the transistor sends out signal through the collector to the relay. This threshold voltage sufficiently switches on, and sustains the connected light points. The variable resistor helps to regulate the degree of conductivity.

3.2 Ultrasonic Pest Repellant Circuit

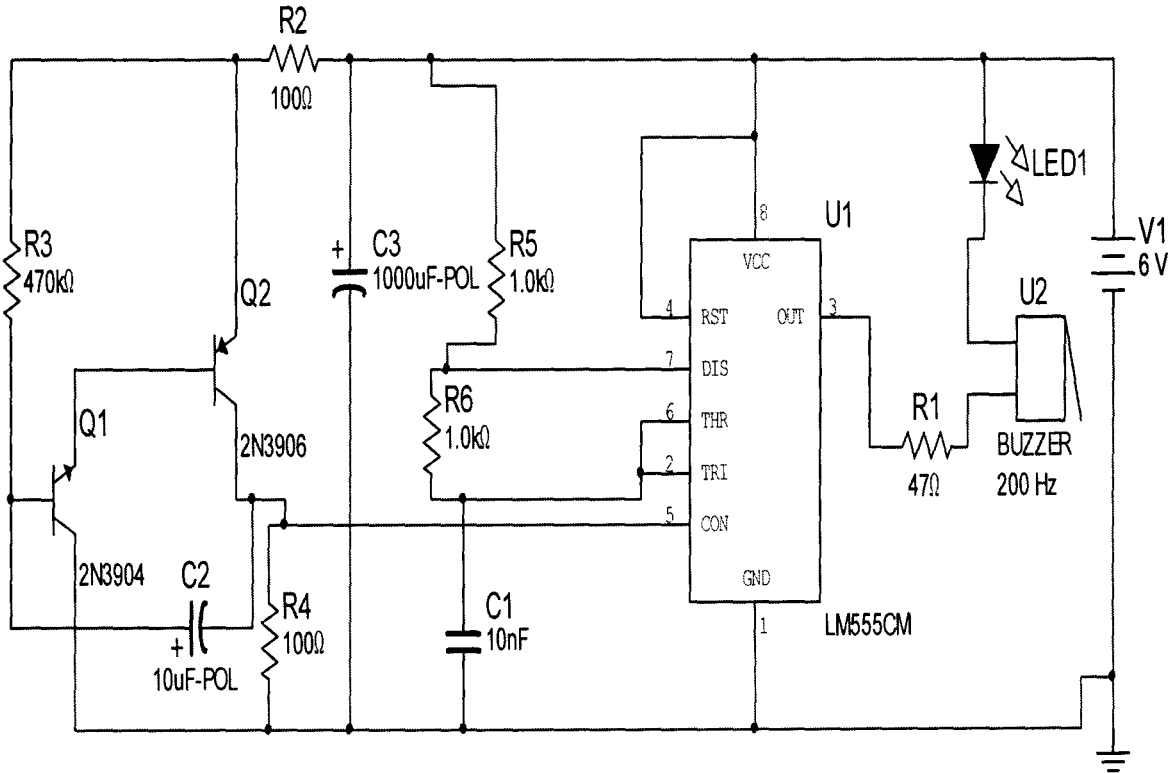

Fig. 3.2 Ultrasonic Pest Repellant Circuit

3.2.1 Design Procedure of Circuit

Fig. 9 shows the circuit of the Ultrasonic pest repellent. To realize this circuit, a 555 Timer was employed, together with transistors Q1 (2N3904), and Q2 (2N3906). Other circuit components include capacitors C1, C2, and C3 (10nF, 10 μ F and 1000 μ respectively). Resistors R1, R2, R3, R4, R5 and R6 (47,100, 470k, 100, 1k, 1k ohms respectively) were used along with an LED. The entire circuitry is powered by a 9V power source. The ultra-sound is output via the 200Hz Buzzer.

Great care was taken to test it on a breadboard before soldering onto a Veroboard. All excess solder were with the use of a soldering aid removed.

3.2.2 Choice of Components

The choice of capacitors and resistors was for the reason of quick charging and discharging. The LM555CM Timer was selected and used due to its versatility. The Buzzer was chosen because of its size, durability and low power consumption.

3.2.3 Workings of the Circuit

The circuit is sufficiently powered by a 9v d.c. supply. Having received power thus, the Darlington pair of transistors Q1 and Q2 amplifies the input to the square of the initial value (Darlington pairs have current gain of β^2 and an approximate voltage gain, A_V of unity).

Capacitor C3 is charged via resistor R2, which in turn sends a pulse to the combined series network of R5, R6 and C1. Capacitor C1 is charged through resistor R5 and R6. The time taken to for the capacitor to charge in this case is

$$10 \times 10^{-9} \times 10 = 10^{-6} \text{ seconds}$$

3.3.1 Design Procedure of Circuit

Beginning with the breadboard work, the circuit was carefully mounted, having obtained all components so required. The ICs were first connected, after which pins were located and other components carefully connected as shown. The work was before this point simulated severally on the software, MULTISIM® to prove its functionality. The breadboard work was also tested by itself first and later in company of other system circuits.

Finally, the proven work was placed on the Veroboard. At this process, extreme care was taken to prevent short circuits arising due to overflow of solder or sticking wires. Polarities were carefully identified with the aid of the multimeter.

3.3.2 Choice of Components

Rather use discrete components to realize the design; ICs CD 4017 and CD 4060 were employed. The 9V relays were used considering the power requirement of the ICs and the circuit as a whole. It proved sufficient for this purpose. The combination of capacitors and resistors were chosen in conformity with the principle of the IC operation.

3.3.3 Workings of the Circuit

The 14-pin counter is triggered into action by a pulse received from a source, say relay via the action of the photocell and transistor amplifier. It counts in powers of 2, up to $2^{14} = 16,384$. This is the initial frequency to which the externally connected oscillator (composed of C1, R6, and R5), sets the circuit. From this point, the frequency is further increased by 10 as it passes into CD 4017, which is a decade counter. As the period elapses after counting, the normally closed relay responsible for switching the indoor lights is opened so that the lights are turned off.

3.4 Light Dimmer Circuit

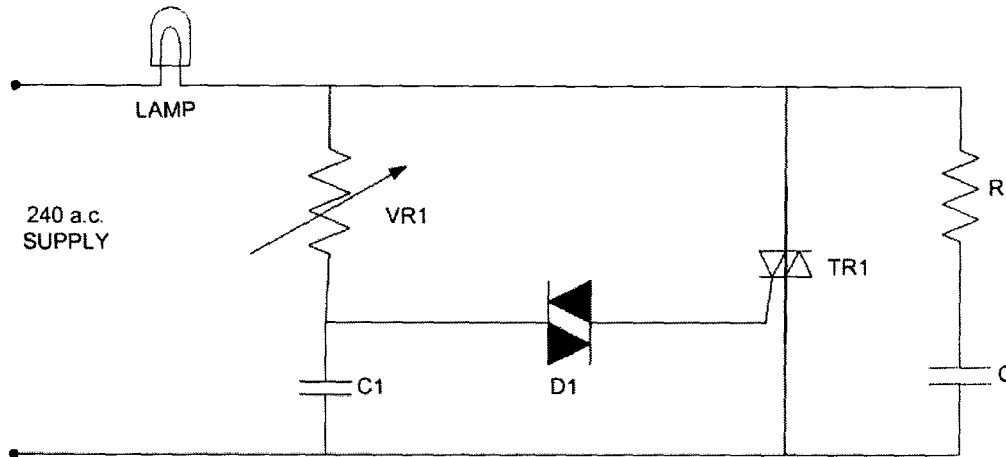

Fig. 3.4 Light Dimmer Circuit

3.4.1 Workings of the Circuit

The circuit above shows the circuit diagram of the Dimmer. In summary, the variable resistor controls the time taken to charge the capacitor, which in turn controls the turn-on time of the TRIAC, which also determines the amount of current through the lamp. This method involves chopping the waveform. It is known as PHASE CONTROL.

The charging time of the capacitor is dependent on the settings of the variable resistor. At minimum setting, the capacitor charges quickly (since resistance to current flow is highly reduced), and continues as such until breakdown voltage of the DIAC is reached. At this, breakover occurs, setting a pulse to the gate of the TRIAC, which lights the lamp until the end of the positive half-cycle.

During the negative half-cycle, the capacitor commences to charge again with the opposite polarity: since none of the components in the circuit are polarized this does not matter. Again the TRIAC is turned on when the breakdown voltage of the DIAC is reached, and current flows through the lamp.

At maximum setting, breakdown voltage is slowly achieved due to the slow rate at which the capacitor charges. As a result of this, the TRIAC switches on towards the end of each half-cycle. Less current flows per time through the lamp thus dimming it.

The resistor-capacitor series network in parallel with the TRIAC “is called a snubber network and prevents false triggering of the device by filtering out high voltage spikes in the mains.”[21]

The circuit above works on the principle of switching, and not the resistive principle used by some other dimmers: thus, no power is wasted in its operation.

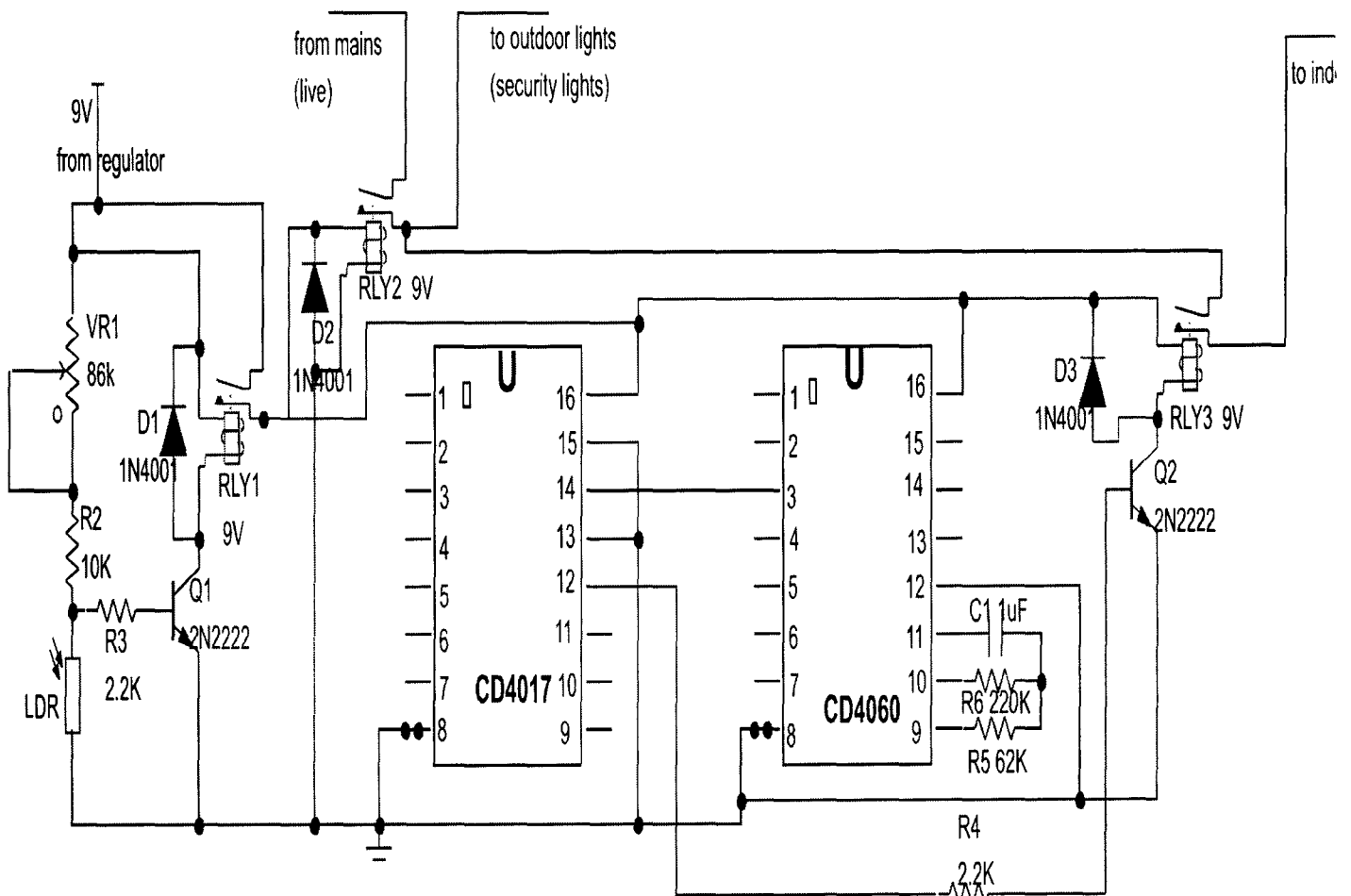

Fig. 3.5 Combined Photo-resistive/ Timer Delay Circuit

3.5 House Model and Wiring: Design Characteristics

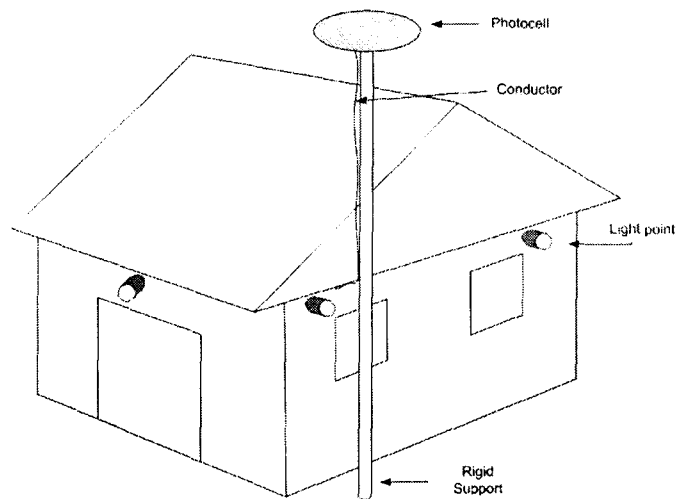

Fig. 12 Automated House showing mounted photocell

3.5.1 Design Characteristics

In implementing this work, the model of a house was made as shown above. Conduit wiring was adopted for the reason of neatness. The photocell was mounted as shown in the diagram. The security lights were connected in a 2-way switch format using the photocell and other security light switches.

In effect, the security lights could be turned on either via the conventional switch or via the photocell (at night-fall). All other parts of the system were connected as shown in Fig.1.

3.5.2 Important Regulatory Considerations

Regulations are not only necessary for order; they help towards uniformity and safety. World over disciplines have constituted bodies that will establish, supervise and enforce such standards. In electrical engineering such standards exist, and the body so responsible is the Institute of Electrical Engineering (IEE). See Appendix B for some guide provided.

Heights of switches and sockets

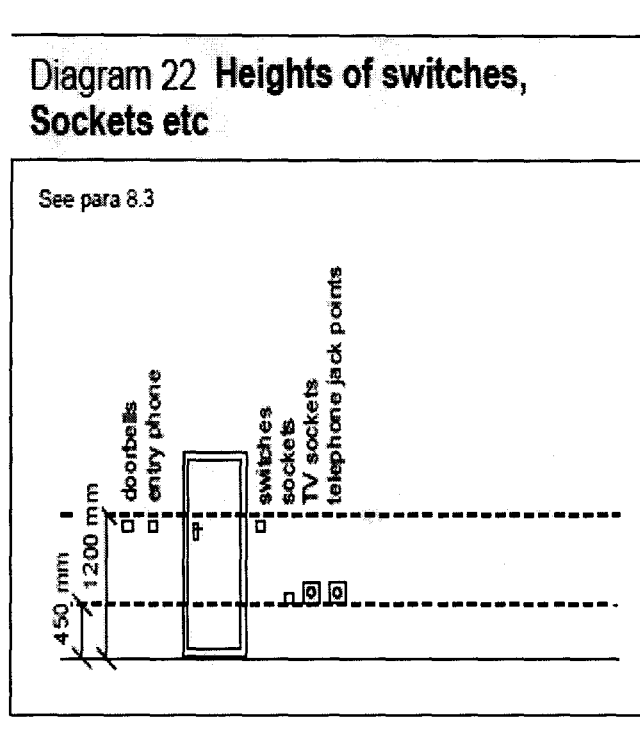

Fig. 3.6 Diagrammatic representation of IEE Regulation
for heights of switches and sockets etc. [20]

The requirements of Section 8 of Approved Document M2 are “...not specifically worded. The intention of approved document M is that reasonable provision shall be made for disabled people to gain access and use a building. The document advises that disabled people mean people who have:

- An impairment which limits their ability to walk or which requires them to use a wheelchair for mobility or
- Impaired hearing or sight...

Approved Document L requires reasonable provision to be made for the conservation of fuel and power including providing lighting systems with appropriate lamps and sufficient controls so that energy can be used efficiently. One way of

demonstrating compliance with the requirements for lighting would be to provide a number of locations with facilities energy efficient light sources. That is with a luminous efficacy greater than 40 lumens per circuit-watt. Equipment that provides such efficiency includes – fluorescent tubes, compact fluorescent tubes as well as the range of discharge lamps that are more commonly used in commercial buildings. Tungsten halogens and standard filament lamps, bayonet or Edison screw are not of sufficient luminous efficiency. The guidance given in L4 is that a minimum number of rooms shall be provided with fluorescent luminaries (including compact fluorescent) and not bayonet lamp holders. A table is provided for determining the number of locations and this is reproduced below as Table 3.1

Table 3.1 Required numbers of light locations per room range. [20]

Number of rooms Created	Recommended number Of locations
1 – 3	1
4 – 6	2
7 – 9	3
10 – 12	4

CHAPTER FOUR

Tests, Results and Discussion

In the course of this project work, a few tests were carried out in other to prove workability, efficiency, probable areas of faults and possible areas of future improvement. Voltages across resistors of different resistances were investigated for conditions of light and shade (not darkness, as that would almost always be the same). The following results were obtained as shown below in Table 4.1

Table 4.1 Resistor/Voltage Test values

Resistor Values Ω	V_{out} with Light V	V_{out} in Shade V	V_{out} Difference V
330	0.09	0.02	0.07
1k	0.28	0.07	0.21
4.7k	1.20	0.33	0.87
12k	2.47	0.77	1.70
22k	3.72	1.41	2.31
47k	5.38	2.64	2.74
100k	6.41	3.80	2.61
200k	7.16	4.82	2.34

4.1 Luminance-Resistivity Test

From the table, it is clear that, more voltage, and invariably current and power is released with different values of resistors in the presence of light, than in darkness. This would be abnormal for a Photocell circuit, except that, in this case, it is designed to present more resistance in the presence of light than before shade or darkness.

It was observed as can also be seen from the table that voltage across resistances varied directly with the respective resistances. That is to say that, the higher the resistance, the higher the amount of current passing through the resistor(s).

This though contrary to the normal working of resistors verifies the functionality of the Photoresistor; which is the major component of the entire project work.

The placement/positioning of the Photocell, proved to be rather important, in that, it needed to be placed on a rigid, high, and non-conducting platform in order to avoid damage due to winds, mischievous human reach, excessive heat which destroys the semi-conduction principle of the LDR. It was observed that with different light sources, the performance varied, improving significantly with the extremes of very bright and very dim or dull illumination.

One more salient observation noted in this experiment is that, voltage values continue to increase only to a point. For example, it can be seen from the table that, with 100k-Ohm, and 200k-Ohm, difference in voltages across the resistors, with respect to Light and Shade begins to drop. This goes to say that, with decrease in illumination, in the presence of a large resistance, of the order of 100k-Ohm and above, greater current, voltage and power consequently, will be given off than in the case of improved illumination. This means that for efficiency of the circuit, and system in general, high resistances should be employed.

4.2 Findings from Delay Circuit

In principle the resistance value (R_2) for the circuitry should not be less than 50k-Ohm. It was observed that anything below that value, would render the system impracticable, and inefficient.

With greater values of the resistor and decreasing values of capacitances, it was observed that, greater time intervals were achieved. This goes to say that variation in the timing is possible, especially if computerization is considered in the near future using the photo-

energy and inverse of the solar system. This also implies that the circuit utilizes relatively small energy since it requires such a large resistance value, as compared to the very meager energy storage of the capacitor.

4.3 Findings from Ultrasonic Circuit

Testing this circuit in particular proved very difficult, largely due to the unavailability of a functional Oscilloscope or such devices. However, on simulation, it proved to be working, giving a value of 25kHz which although just enough to perform the desired function is not at its optimal performance.

Although, it is theoretically stated that such high frequencies performs the desired function of repelling pests, it has been shown that unless this frequency is varied periodically, rodents especially would accustom themselves to it, thereby rendering the whole system unreliable.

On the part of Automation, the circuit was proven to at least indicate functionality without any form of human interference.

CHAPTER FIVE

Conclusions and Recommendations

5.1 Conclusions

From the work done so far, it is evident that using simple and available devices a home (or house) could be automated, at least partially.

5.2 Recommendations

A number of improvements may be made on this work that time constraints did not permit; some of which include:

- i. Implementing the same project using the heat of the sun, that is solar energy, and not only the photo-energy of the sun.
- ii. Automating other sections of the house, viz., the heating system, cooling system, security system etc.
- iii. Computerizing the system as the economy and standard of living improves.

REFERENCES

- [1] E.P. Popor, E.I. Yurevich: Robotics, Mir Publ., p.26
- [2] Edward Hughes; Hughes Electrical Technology, 7th Ed. Longman Singapore Publishers Ltd. p. p. 438, 512 – 513.
- [3] http://www.homeseer.com/how_to.htm
- [4] By Debbie Hardy. Ralph: The Home Assistant Post-Polio Health (Fall 2004; Vol. 20, No. 4).
- [5] <http://www.ralphmyfriend.com/>
- [6] Michael Talbot-Smith; Audio Explained; Focal Press, Biddles Ltd. Great Britain U.K. p. 13
- [7] <http://www.bebek.fi/>
- [8] http://www.ndt-ed.org/index_flash.htm
- [9] [Phys Ther. 1996 Jan;76\(1\):78-9. ; http://www.ncbi.nlm.nih.gov/entrez/query.fcgi](http://www.ncbi.nlm.nih.gov/entrez/query.fcgi)
- [10] Burnie, David, and Tschinkel, Walter R. "Insect." *Microsoft® Encarta® 2006* [DVD]. Redmond, WA: Microsoft Corporation, 2005.
- [11] B.L. Theraja, A.L. Theraja: A Textbook of Electrical Technology, 23rd Ed. S.Chand & Co. Ltd. p. 1722
- [12] William L. Faissler: An Introduction to Modern Electronics; John Wiley & Sons, Inc. U.S.A p. 207
- [13] Tony von Roon: <http://www.noguelph.ca/antoon>
- [14] http://epanorama.net/documents/lights/light_dimmer.html
- [15] D.C. Green Electronics II 4th Ed. Longman Scientific & Technical, Longman Group U.K. Ltd. P. 72.

- [16] Ralph J. Smith; Circuits, Devices, and Systems: A First Course in Electrical Engineering 3rd Ed John Wiley & Sons Inc. U.S.A. p. 348
- [17] <http://www.tlc-direct.co.uk/Book/7.1.1.htm>
- [18] http://en.wikipedia.org/wiki/4000_series
- [19] Horowitz P., Hill W; The Art of Electronics 2nd Ed; Cambridge University Press/Gopsons Paper Ltd., NOIDA, India. p. 522
- [20] Wiring Matters Adobe Acrobat Professional
2002_12_autum_switch_height_energy_efficiency_html
- [21] R.D. Puckering and S.Brough: Electronics for Electrical Installation, Blackwell Scientific Publ., p. 142-144
- [22] Dr. Bianco

Appendices

Appendix A - Logic CMOS - CD4000 Series





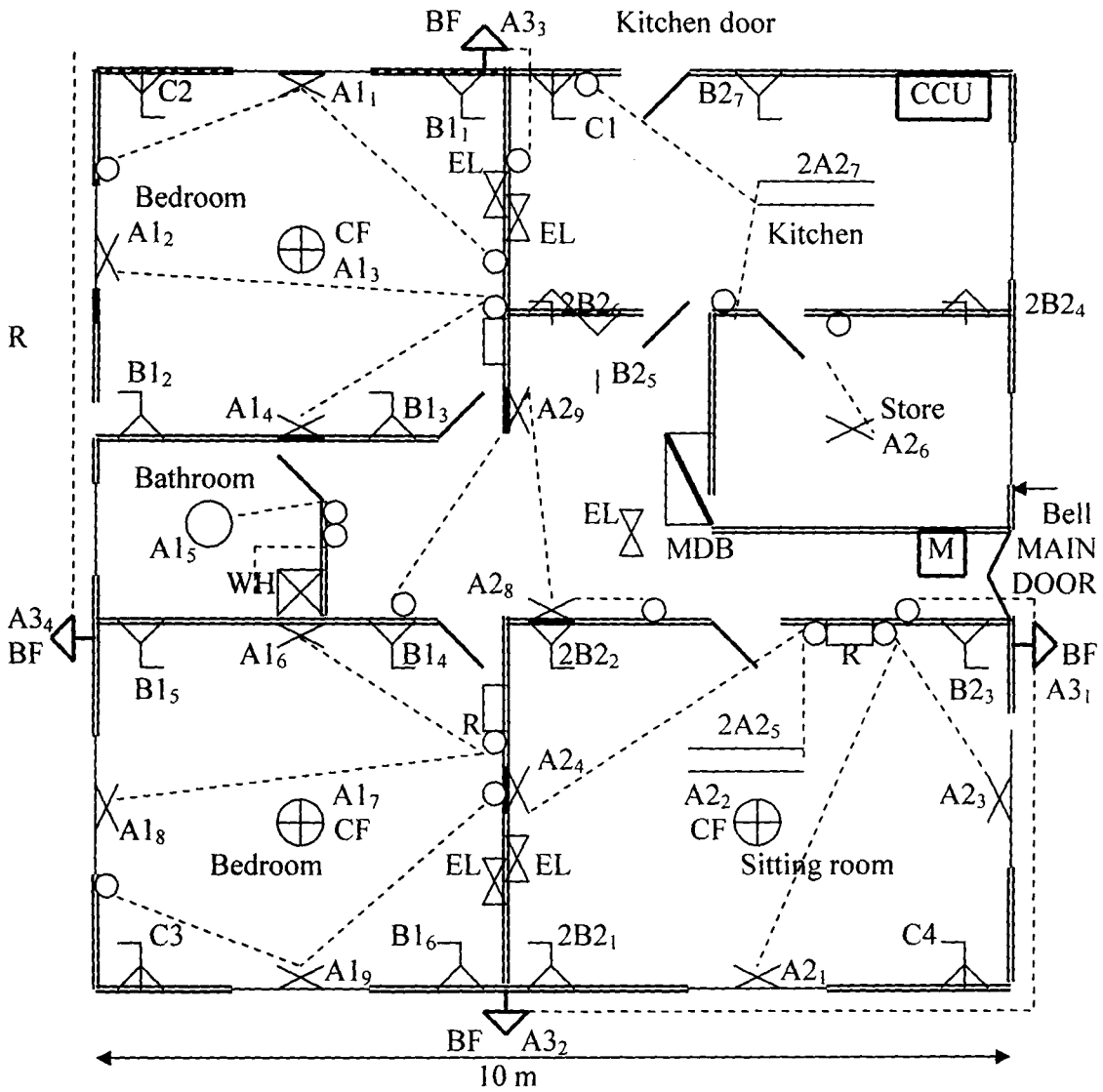











<u>CD4001</u>	Quad 2 input NOR gate	<u>CD4050</u>	Hex buffer / converter non-inverting	<u>CD4538</u>	Dual precision monostable multivibrator
<u>CD4002</u>	Dual 4 input NOR gate	<u>CD4051</u>	8 channel MUX	<u>CD4543</u>	BCD to 7 segment LCD driver
<u>CD4007</u>	Dual comp pair plus inverter	<u>CD4052</u>	Differential 4 channel MUX	<u>CD4555</u>	Dual binary to 1 of 4 decoder
<u>CD4008</u>	4 bit full adder	<u>CD4053</u>	Triple 2-channel analog multiplexer	<u>CD4556</u>	Dual binary to 1 of 4 decoder
<u>CD4009</u>	Hex buffer / converter inverting	<u>CD4054</u>	4 segment LCD driver	<u>MC14557</u>	Variable Length Shift Register
<u>CD4010</u>	Hex buffer / converter non-inverting	<u>CD4055</u>	BCD to 7 segment decoder / driver	<u>MC14584</u>	Hex Schmitt Trigger
<u>CD4011</u>	Quad 2 input NAND gate	<u>CD4056</u>	BCD to 7 segment decoder / driver		
<u>CD4012</u>	Dual 4 input NAND gate	<u>CD4059</u>	Programmable divide by N counter		
<u>CD4013</u>	Dual D-Type flip flop with set/reset	<u>CD4060</u>	14 stage ripple carry binary counter / divider		
<u>CD4015</u>	Dual 4 stage static shift register	<u>CD4063</u>	4-bit comparator		
<u>CD4016</u>	Quad bilateral switch	<u>CD4066</u>	Quad bilateral switch		
<u>CD4017</u>	Decade counter	<u>CD4068</u>	8-input NAND/AND gate		
<u>CD4018</u>	Preset Divide by N counter	<u>CD4069</u>	Hex inverter		
<u>CD4020</u>	14 stage binary counter	<u>CD4070</u>	Quad 2 input XOR		
<u>CD4022</u>	Octal counter	<u>CD4071</u>	Quad 2 input OR		
<u>CD4023</u>	Triple 3 input NAND gate	<u>CD4072</u>	Dual 4 input OR gate		
<u>CD4024</u>	7 stage binary counter	<u>CD4073</u>	Triple 3 input AND gate		
<u>CD4025</u>	Triple 3 input NOR gate	<u>CD4075</u>	Triple 3 input OR gate		
<u>CD4026</u>	Decade counter / divider	<u>CD4077</u>	Quad 2 input XNOR gate		
<u>CD4027</u>	Dual JK master - slave flip flop	<u>CD4081</u>	Quad 2 input AND		
<u>CD4028</u>	BCD to decimal decoder	<u>CD4082</u>	Dual 4 input AND gate		
<u>CD4030</u>	Quad 2 input XOR gate	<u>CD4089</u>	Binary rate multiplier		
<u>CD4033</u>	Decade counter / divider	<u>CD4098</u>	Dual monostable multivibrator		
<u>CD4035</u>	4 stage PIPO shift register	<u>MC14469</u>	Addressable UART		
<u>CD4040</u>	12 stage binary counter	<u>MC14495</u>	BCD 70 &-seg latch/decoder/driver		
<u>CD4041</u>	Quad true / compliment buffer	<u>CD4503</u>	Hex buffer		
<u>CD4042</u>	Quad clocked D latch	<u>CD4504</u>	Hex voltage level shifter TTL-CMOS		
<u>CD4043</u>	Quad 3 state R/S latch NOR	<u>CD4511</u>	BCD to 7 segment latch decoder drivers		
<u>CD4044</u>	Quad 3 state R/S latch NAND	<u>CD4514</u>	4 bit latch / 4 to 16 line decoders		
<u>CD4046</u>	Phase locked loop	<u>CD4515</u>	4 bit latch / 4 to 16 line decoders		
<u>CD4047</u>	Monostable / Astable multivibrator	<u>CD4518</u>	Dual BCD up counter		
<u>CD4049</u>	Hex buffer / converter inverting	<u>CD4520</u>	Dual binary up counter		

Appendix B-1: LAYOUT DRAWING OF A 2-BEDROOM HOUSE



Adapted From Lecture Notes on Electrical Services Design by M.D Abdullahi

Appendix B-2
Legend for Layout Appendix B-1

Symbol	Description	Symbol	Description
	Energy meter		2 x 40 W 4 ft. fluorescent fitting
	Main Distribution Board (MDB)		Ceiling fan with Regulator (60 W)
	5 A single-pole one-way switch		Wall-mounted lamp 60 W
	5 A two-pole one-way switch		Emergency (Safety) Light
	5A Single-pole two-way switch		Water heater
	13 A Switched socket Outlet		Ceiling-mounted lamp 60 W
	13 A Switched socket outlet for two plugs		Cooker control unit
	15 A Switched socket Outlet		100 W bulkhead fitting

Load schedule and power estimation

No.	Description	No. of Points	Point Load	Total Load	Fuse (A)	D.F. %	Load Est. W	Cable mm ²
A1	Light bulbs	7	60	420	10	66	280	1.5
A1	Ceiling fans	2	60	120	10	66	80	1.5
A2	Light bulbs	6	60	360	10	66	240	1.5
A2	Ceiling fans	1	60	60	10	66	40	1.5
A2	Fluorescent	2	80	160	10	66	107	1.5
A3	Sec. light	4	100	400	10	66	267	1.5
B1	13 A S.S.O.	6	200	1,200	15	60	720	2.5
B2	13 A S.S.O.	3	200	600	15	60	360	2.5
B2	13 A D.S.O	4	400	1,600	15	60	960	2.5
C1	15 A S.S.O	1	2,000	2,000	20	100	2,000	4.0
C2	15 A S.S.O	1	2,000	2,000	20	100	2,000	4.0
C3	15 A S.S.O	1	2,000	2,000	20	100	2,000	4.0
C4	15 A S.S.O	1	2,000	2,000	20	100	2,000	4.0
C5	W. heater	1	2,000	2,000	20	100	2,000	4.0
D	Cooker	1	3,000	3,000	30	100	3,000	6.0
-	Bell & co.	1	Neg.	-	-	-	-	-
	Total	-	-	17,920	-	-	16,054	-