

**DESIGN AND CONSTRUCTION OF AN
ULTRASONIC INTRUDER DETECTOR**

BY

NDAEJI ANDREW BABA

95/4551EE

**IN PARTIAL FULFILMENT OF THE REQUIREMENT FOR THE
AWARD OF BACHELOR OF ENGINEERING (B.ENG) DEGREE
IN ELECTRICAL/COMPUTER ENGINEERING DEPARTMENT
FEDERAL UNIVERSITY OF TECHNOLOGY
MINNA, NIGER STATE.**

DECEMBER, 2000

DECLARATION

I do hereby declare that this work piece carried out by me under the supervision of Mr. Usman Abraham Usman and Presented in Partial fulfilment of the requirement for the award of Bachelor of Engineering (B.Eng) degree has not be presented either wholly or partially for anyother degree elsewhere. Information and data obtained from published or unpublished works of other people have been dually acknowledged.

Ndaeji Andrew Baba

Date.

APPROVAL

I hereby certify that this project was carried out by Mr Ndaaji Andrew Baba of the department of Electrical and computer Engineering under my supervision.

ENGR. ABRAHAM USMAN.

Supervisor

Date

Signature

ENGR. (DR.) Y. A ADEDIRAN.

Head of Department

Date

Signature

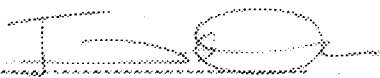

17/1/01

External Supervisor

Date

Signature

DEDICATION

To Mama with Love.

To Micheal Tsado Ndeaji (Jr) for Papa.

And to God Almighty for so long His power hath kept me, sure it still will lead
me on.

ACKNOWLEDGEMENT

I am forever grateful to the El-shaddai-the Almighty, my maker, my protector and my source of inspiration. He brought me out of the miry clay and set my feet on the solid rock to stay.

To my supervisor, Mr Abraham Usman, I say thank you for being so supportive. I appreciate your encouragement.

And to all the lecturers of the Electrical and Computer Engineering department, especially my H.O.D, Mr Y.A Adediran, Mr Danjuma and Mr Paul Aitah.

I say thank you all for impacting on me all that I know now.

I cannot but appreciate one woman without whom the story of my life would have had no beginning Mrs Rebecca Abu Ndaeji. When I was born she gave me all care and affection, when I grew up she gave me all I needed to know in life – Mama thank you for your Love and care, I appreciate everything you did for me. Your labour of Love will not go in vain. To Nna manima I say thank you for your love. I will live for everything you stood for.

To my dearly beloved brother Mr Joel Tsado Ndaeji, I say thank you for being there for me. I am most grateful for everything you did for me. I just cannot find the right words to express my gratitude. for your kindness was extra ordinary. Infact I believe you are a gift from God for me. May this seed of love that you sow continue to grow from generation to generation.

My sincere gratitude also goes to my brother Mr R.T Ndaeji who doubles as my father. Ya Reuben I appreciate every of your effort. Thank you very much for all those good counsels. To Mrs C.F Ndaeji I also say thank you. To Grace I appreciate you.

Mr & Mrs Eli .T. Ndaeki, Mr & Mrs A.N.Yisa, Mr & Mrs J.N. Tsado, I acknowledge your contributions and support, thank you all for your kindness.

This acknowledgement will not be completed if I fail to acknowledge the love and affection shown to me by Mr Jonah Kolo and Mr & Mrs Benjamin Tsado. You added colour to my life and made thing easier for me. I am most grateful for your support.

My "friends indeed" deserve my commendation and so I say thank you to all. And to my dear sister Mary, I say thank you for being so caring and thoughtful.

TABLE OF CONTENTS

CONTENTS	PAGE
TITLE	i
DECLARATION	ii
APPROVAL	iii
DEDICATION	iv
ACKNOWLEDGEMENT	v
TABLE OF CONTENTS	viii
ABSTRACT.	ix
CHAPTER ONE	
1.0 GENERAL INTRODUCTION	1
1.1 PREAMBLE	1
1.2 AIMS AND OBJECTIVE	2
1.3 APPLICATIONS	5
1.4 LITERATURE REVIEW.	5
CHAPTER TWO	
2.0 THEORY AND DESIGN ANALYSIS	8
2.1 VELOCITY OF ULTRASONIC WAVES	8
2.2 TRANSMITTER CIRCUIT	9
2.3 CLOCK GENERATOR-ASTABLE MULTIVIBRATOR	9
2.4 OPERATING FREQUENCY OF ULTRASONIC TRANSDUCERS	15
2.5 THE RECEIVER CIRCUIT	15
2.6 THE FILTER	15

2.7	A.C AMPLIFIER	22
2.8	SIGNAL COMPARATOR	25
2.9	TONE GENERATOR	32
2.10	ELECTRICAL CHARACTERISTICS OF ULTRA-SONIC TRANSDUCER	34
2.11	THE POWER SUPPLY UNIT	35
 CHAPTER THREE		
3.0	LAYOUT AND CONSTRUCTION	38
3.1	MATRIX BOARD LAYOUT	38
3.2	CONSTRUCTION	39
 CHAPTER FOUR		
4.0	TESTS, MEASUREMENTS AND PROBLEMS ENCOUNTERED	41
4.1	TESTS AND MEASUREMENTS	41
4.2	PROBLEMS ENCOUNTERED.	42
 CHAPTER FIVE		
5.0	CONCLUSIONS AND RECOMMENDATIONS	43
5.1	CONCLUSIONS	43
5.2	RECOMMENDATIONS.	43
	REFERENCES	44
	APPENDIX: - LIST OF COMPONENT USED	46

ABSTRACT

This project report presents the concept of the design and construction of an ultrasonic intruder detector.

This project was carried out to improve on the existing burglar alarm system to make them more fool proof.

The uniqueness of this system to others is the use of ultra-sound (inaudible sound). For intrusion detection, a short burst of ultrasonic is sent through an ultrasonic transmitter and receiver by a sensor (ultrasonic receiver). Reception continues until an intruder alters it. When an intruder an alarm breaks transmission and reception path is triggered on.

The theory and design analysis was carried out and a satisfactory result was obtained, that is the circuit worked and the device became a reality after all.

CHAPTER ONE

1.0 GENERAL INTRODUCTION:

1.1 PREAMBLE [1, 4]

Energy is familiar to us in many ways such as light, heat, Kinetic and potential, electrical and magnetic energy, all which we consider very important and useful in our daily living. In the same way sound is also a form of energy. Just as it is customary to regard light and heat as radiation in visible, ultra violet and infrared sections of electromagnetic spectrum, sound can also be regarded as mechanical vibrations having frequencies from a few cycle to ultrasonic vibrations. Human ear is sensitive to mechanical vibrations ranging from 20HZ to 20,000 HZ and this range is called the audible range. Above this frequency, the vibrations are called ultrasonic vibrations. An important difference, however, exists between the vibrations producing light and those producing sound. Light vibrations are transverse, that is vibrations are perpendicular to the direction of propagation but in the case of sound, vibrations are longitudinal that is, they take place in the same direction as the direction of propagation.

This peculiar property of sound is what is explored by this project.

This report describes the design and construction of an ultrasonic intruder detector.

The term ultrasonic refers to the science and technology dealing with acoustics waves (elastic waves or stress waves i.e mechanical waves) the frequency of which is higher than the nominal limit, of audibility by human ear. It must be called nominal limit, since it is not definite in exact terms, only on some statistical basis because it also depends on sex and age, and it varies considerably from person to person. So as a

convention 20,000HZ is usually taken as the lower frequency limit of ultrasound waves. This fascinating world of silent sounds-sounds that are not audible by human ear, starts from 20KHZ and extends to about 500,000HZ.

The device is composed of four functional blocks-the clock generator the ultrasonic transmitter, receiver and the alarm circuits. Each block is in itself a simple circuit with few individual components. Fig1.1 shows the block diagram of the ultrasonic intruder detector.

For intrusion detection, the transmitting transducer sets up a pattern of ultrasonic wave passed in the form of a beam to the receiver. An intruder alters the ultrasonic wave pattern setting on an alarm. In this an ultrasonic precisely 40,000HZ is sent through the transducer (piezo speaker). The transmitted sound wave is received by another transducer (ultrasonic receiver), the received signal is filtered and amplified but at intrusion, reception is broken and the alarm is activated or triggered.

1.2 AIMS AND OBJECTIVES

Nature has been so benevolent to man by lots of resources at his disposal that man has not even been able to fully explore these resources. Sound as a form of energy as earlier discussed is one of such resources. Detecting an intruder, thereby preventing intrusion is by far better and preferable to all other actions that may be taken as an aftermath of intrusion.

Light as a form of energy has been extensively explored and judiciously utilized, part of which was the building of the infra-red intrusion detector. And from the vast

discoveries of the applications of ultrasonic vibrations, it was discovered that ultrasound could also be used to detect intrusion in a much better way than the infrared light.

It is this discovery that gave birth to this project.

The advantage of using ultrasonic sound is that it is not visible and audible (it can not be seen or heard). And it is not sensitive to objects of different colours and light reflective properties. Ultra- sound is transmitted via a transducer and received by another transducer (ultrasonic receiver). An intruder alter this reception and an alarm is set on, the alarm indicates the presence of an intruder to which a quick response can be given to prevent intrusion.

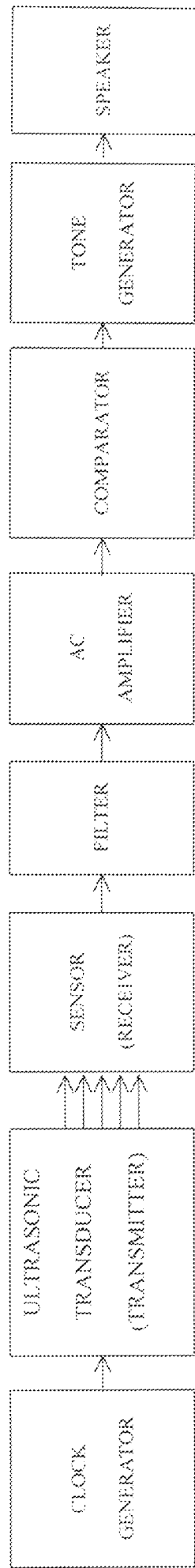

FIG 1.1 BLOCK DIAGRAM OF THE ULTRASONIC INTRUDER DETECTOR

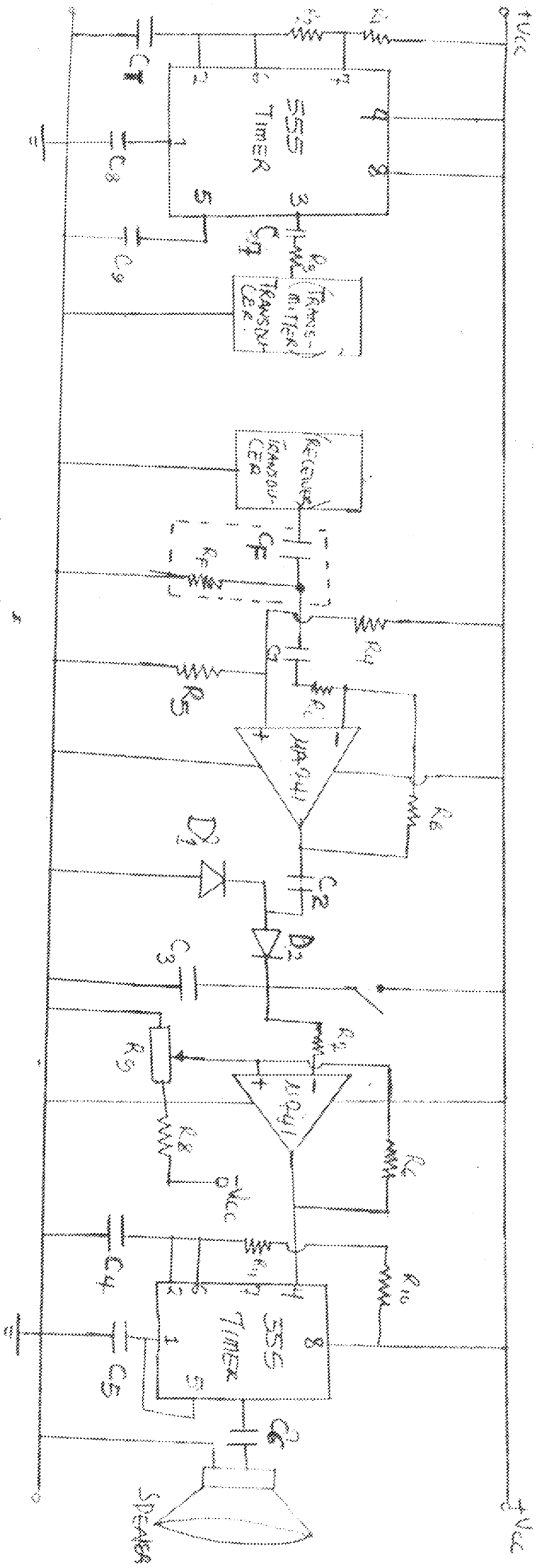

FIGURE 1.2 CIRCUIT DIAGRAM OF AN ULTRASONIC INTRUDER DETECTOR.

1.3 APPLICATIONS

As the name of the device implies, it is used to detect an intruder and consequently preventing intrusion.

1.4 LITERATURE REVIEW [4,5,6,7,8]

Man has over the years developed devices to reproduce, ultrasonic waves. These reproducers or, transducers are classified either as mechanical or electronic

As frequency of sound waves goes up and the wavelength goes down, a beam of sound diverges to a smaller extent and is less easily defracted, and is reflected by smaller and smaller objects.

Until about 1910 ultrasonic waves were little more than a scientific curiosity. Though the possibility of making use of ultrasonic beam because of practical purposes dates back to 1880's. James Prescott Joule (in 1846) and later more extensively, George Washington pierce, investigated the phenomenon that a ferromagnetic bar expands when it is weakly magnetized but contracts when magnetic saturation is reached, such mechanical (dimensional) changes due to changes in magnetic field are called magnetostictive effects. When these changes are of a linear nature they are known as the Joule effect, which is of great important in producing ultrasonic oscillations for commercial applications.

The piezo electric or pressure-electrical phenomenon was first discovered and studied by Pierre curie a French scientist as early as 1880. Asymmetrical crystals such as Rochelle salt and quartz generate an electric charge on their surfaces when mechanical stresses are applied. When pressure is applied to such a crystal its faces become

electrically charged --one positive, the other negative. When tension is applied, these electrical charges are reversed. Thus mechanical vibration is transformed into electrical oscillations. The phenomenon is called the direct piezo electric effect. Pierre curie and his brother also discovered that if a difference in voltage is set up in metal plates held against opposite faces of the crystal, a small compression is induced in the crystal. This phenomenon is called the inverse piezoelectric effect.

The inverse piezo electric effect can be used to produce ultrasonic waves. If a voltage is applied and removed rapidly, the crystal expands and contracts with equal rapidity and sets up the surrounding medium. By speeding up the applied --voltage cycle sufficiently, one can produce ultrasonic beams. If the voltage cycle is equal to the natural frequency of the quartz crystal, the beam will build up to considerable strength

In 1917, after the development of the electron tube, the French physicist Paul langevin succeeded in setting up an electric circuit that produced strong ultrasonic beams. This was during World War 1 and langevin attempted to use such beams to detect submarines under water. Ultrasonic pulse can be sent methodically outward in ever-changing directions (scanning), and when a pulse strikes a submarine, it is reflected. The direction from which a returning pulse is reflected is the direction of the submarine. The distance of the submarine can be estimated by noting the time lapse between the transmission and the return of the reflected pulse and by knowing the velocity of sound in water.

In 1920s, ultrasound was put at work in peaceful ways. It was used to measure the depth of sea bottom, providing a vast improvement over the usual method of dropping a sound line over board. The locations of schools of fish, hidden reefs, or under water

portions of icebergs could also be determined using ultrasound. During World War II, the use of ultrasonic pulses for the detection of enemy vessels came to maturity. This system was named sonar used in detecting the presence of sub-merged submarines.

Ultrasonic waves (vibrations or beams) have also been used for the purpose other than echolocation.

Strong rapid vibrations can shake grime loose, and therefore, they have been used in industries to clean parts and assemblies. Ultrasonic beams have also been used to penetrate steel girders in search of gas bubbles and other flaws. Other attempted early applications were as means of communication and as light modulators in early experiments with television.

Until the 1940s, occasionally even during the early 1950s acoustic waves of frequency above audibility were called supersonic or hypersonic waves. The term supersonic about that time became reserved for speed exceeding the velocity of sound while the term hypersonic was simply dropped. However, the latter term is making a return in recent years, but with a different meaning. As the use of higher and higher frequencies is becoming feasible, some people are beginning to call acoustic waves from around 1 GHz hypersonic.

Generally ultrasonic beams are very sensitive and complicated.

CHAPTER TWO

2.0 THEORY AND DESIGN ANALYSIS

INTRODUCTION

As earlier stated in chapter one, sound can be used in the same way as infrared light to detect intrusion.

To detect intrusion by the ultrasonic intruder detector, a short burst of ultrasound is transmitted by an ultrasonic transducer and received by another transducer (a sensor) placed on the opposite side of the transmitter.

The transmission is kept continuous (constant) and consequently the reception until altered by an intruder. The intruder interrupts the transmission path and stops reception thereby triggering an alarm.

2.1 VELOCITY OF ULTRASONIC WAVES [2,4]

There has been some inconsistency in the velocity of sound determination between the results obtained from different experiments. It is natural to suppose that in the long base line taken in the open-air determination of the velocity of sound, the temperature, pressure and humidity may change from time to time and then combined with personal equation of the observer and the different intensities of the sources of sound are sufficient to explain the discrepancy among observations. In order to eliminate these difficulties, T.C. Hebb at the suggestion of A.A. Michelson devised a method of determining the velocity of sound by accurately measuring the wavelength of sound in air from a source of known frequency.

After series of observations, Hebb obtained the mean value for V as $331.29 \pm 0.4\text{m/s}$. The theoretical value for the velocity of sound comes as 331.80m/s .

The velocity of sound is given by

$V = \lambda f$ but as the frequency of the sound increases, i.e. tends to ultrasonics the wavelength decrease. Therefore ultrasonic have short wavelength compared to sound waves in the audio frequency range.

2.2 TRANSMITTER CIRCUIT

The transmitter circuit comprises of the clock generator and the ultrasonic transmitter (transducer).

2.3 CLOCK GENERATOR ASTABLE MULTIVIBRATOR.

For this project the pulse generator is the popular 555 integrated circuit timers, and it is used in the astable multivibrator mode. The A stable multivibrator has no stable states, consequently, it continually changes back and forth between two states at a predictable rate.

Below is a pin diagram of an 8-pin package 555 timers.

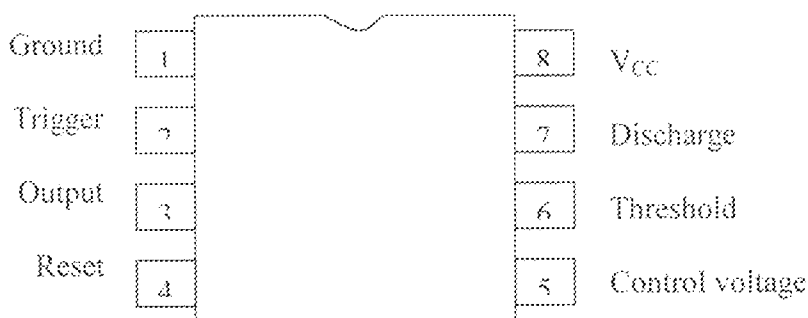

FIG 2.1 PIN DIAGRAM OF A 8-PIN PACKAGE 555 TIMER.

Figure 2.2 also shows the 555 timer connected in the A stable multivibrator mode

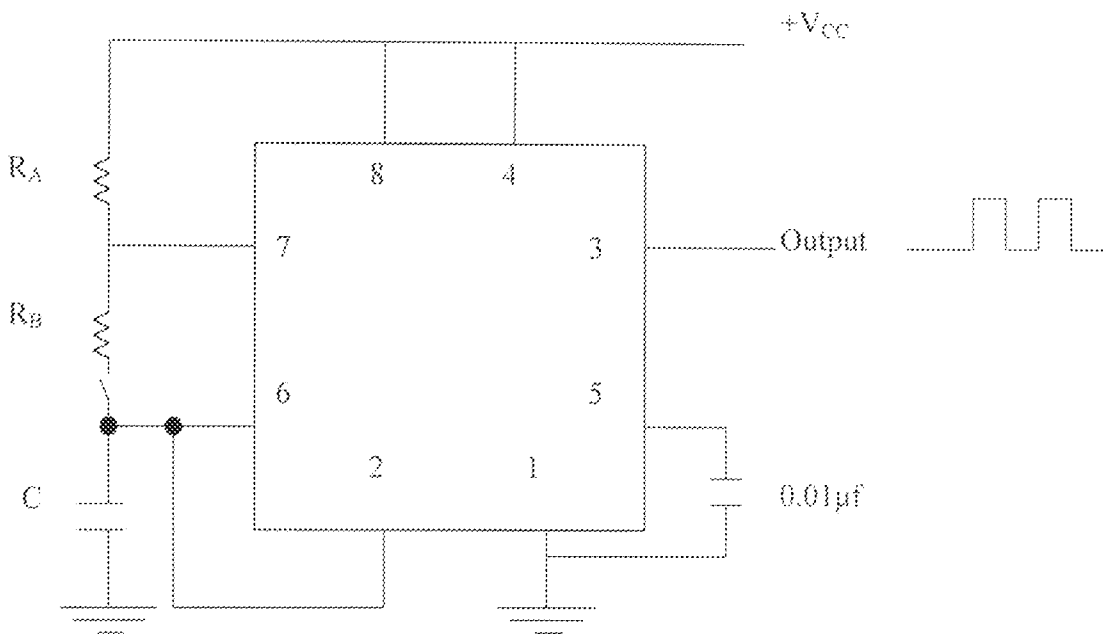

FIG 2.2 Astable Multivibrator Using 555 Timer.

For clarity and better understanding we shall consider the complete diagram of the Astable multivibrator with detailed internal diagram of the 555 timer as shown in fig 2.2

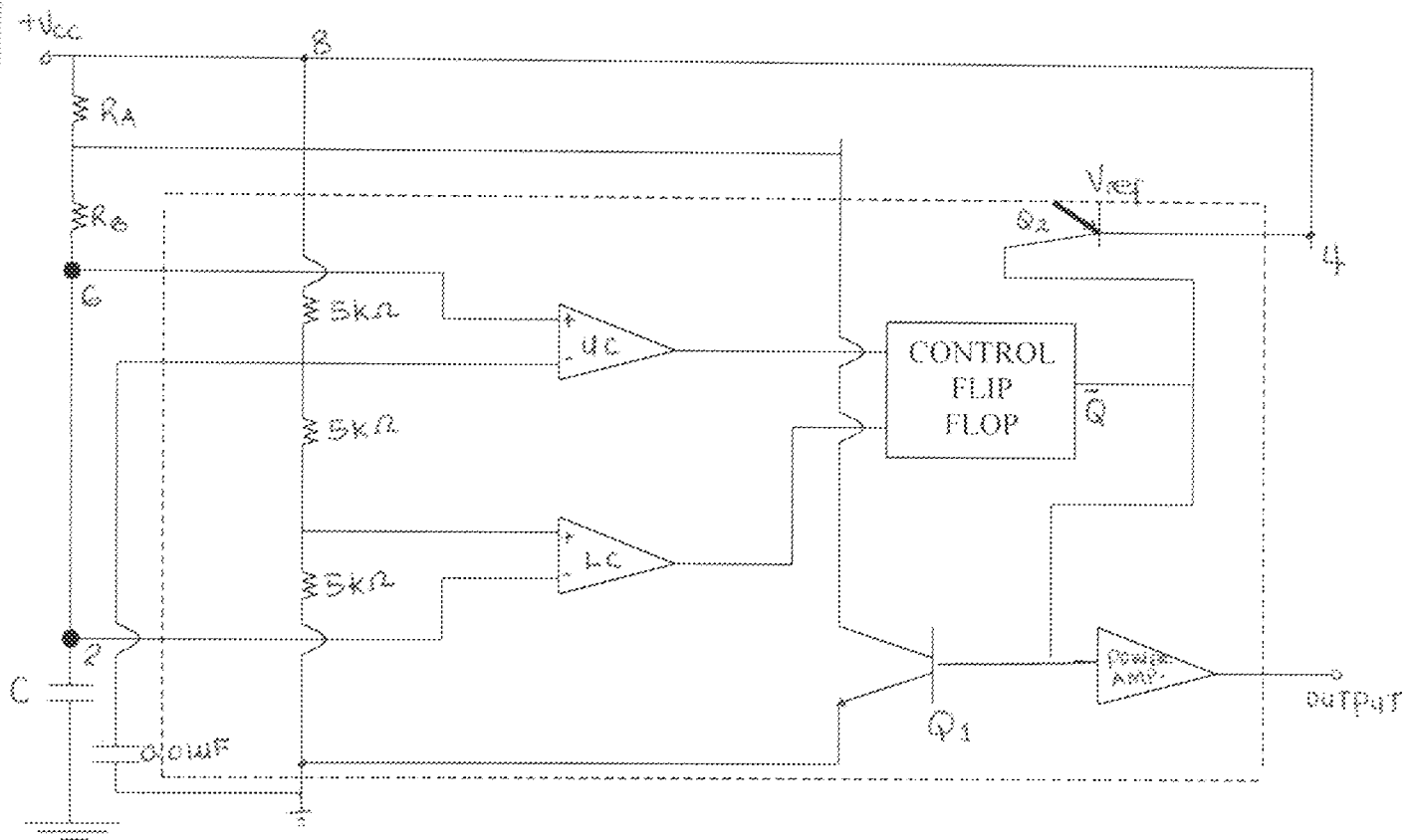

FIG 2.3 FUNCTIONAL DIAGRAM OF ASTABLE MULTIVIBRATOR USING 555 TIMER.

The timing resistor is split into two sections R_A and R_B . When the power supply V_{cc} is connected, the external timing capacitor C charges towards V_{cc} with a time constant $(R_A + R_B)C$. during this time, output (pin 3) is high (equals V_{cc}) as Reset $R = 0$, set $S = 1$ and this combination makes $Q = 0$ which has unclaimed the timing capacitor C .

When the capacitor voltage equals (to be precise is just greater than), $(2/3)V_{cc}$ the upper comparator triggers the control flip-flop so that $q = 1$. This, in turn, makes transistor Q_1 ON and capacitor C starts discharging towards ground through R_B and transistor Q_1 with a timer constant $R_B C$ (neglecting the forward resistance of Q_1). The

minimum value of R_A is approximately equal to $V_{cc}/0.2A$ where $0.2A$ is the maximum current through the ON transistor Q_1 .

During the discharge of the timing capacitor C , as it reaches (to be precise is just less than) $V_{cc}/3$, the lower comparator is triggered and at this stage $S = 1$, $R = 0$, which turns $Q = 0$. Now $Q = 0$ unclamps the external timing capacitor C . the capacitor C is thus periodically charged and discharged between $(2/3) V_{cc}$ and $(1/3) V_{cc}$ respectively. Figure 2.2.4 below shows the timing sequence and capacitor voltage waveform. The length of the time that the output remains HIGH is the time for the capacitor to charge from $(1/3) V_{cc}$ to $(2/3) V_{cc}$. It is calculated as follows:

The capacitor voltage for a low pass RC circuit subjected to a step input of V_{cc} volts is given by

$$V_{cc} = V_{cc} (1 - e^{-t/RC})$$

The time t_1 taken by the circuit to charge from 0 to $(2/3) V_{cc}$ is

$$(2/3)V_{cc} = V_{cc} (1 - e^{-t_1/RC})$$

Or $t_1 = 1.09RC$ and time t_2 to charge from 0 to $(1/3) V_{cc}$ is $(1/3) V_{cc} (1 - e^{-t_2/RC})$(2)

$$t_2 = 0.405RC$$

Or $t_2 = 0.405RC$

So the time to charge from $(1/3) V_{cc}$ to $(2/3) V_{cc}$ is $t_{high} = t_1 - t_2$

$$\begin{aligned} T_{high} &= 1.09RC - 0.405RC \\ &= 0.69RC \end{aligned}$$

so, for the given circuit,

$$t_{high} = 0.69 (R_A + R_B) C$$

the output is low while the capacitor discharges from $(2/3)V_{cc}$ to $(1/3)V_{cc}$ and voltage across the capacitor is given by

$$(1/3)V_{cc} = (2/3)V_{cc} e^{-t/RC}$$

Solving, we obtain

$$t = 0.69RC$$

So for the given circuit $t_{low} = 0.69R_B C$.

Note that both R_A and R_B are in the charge path, but only R_B are in the charge path, but only R_B is in the discharge path. Therefore, total time,

$$T = t_{high} + t_{low}$$

$$\text{Or } T = 0.69 (R_A + 2R_B) C$$

$$\text{So, } f = \frac{1}{T} = \frac{1.45}{(R_A + 2R_B) C}$$

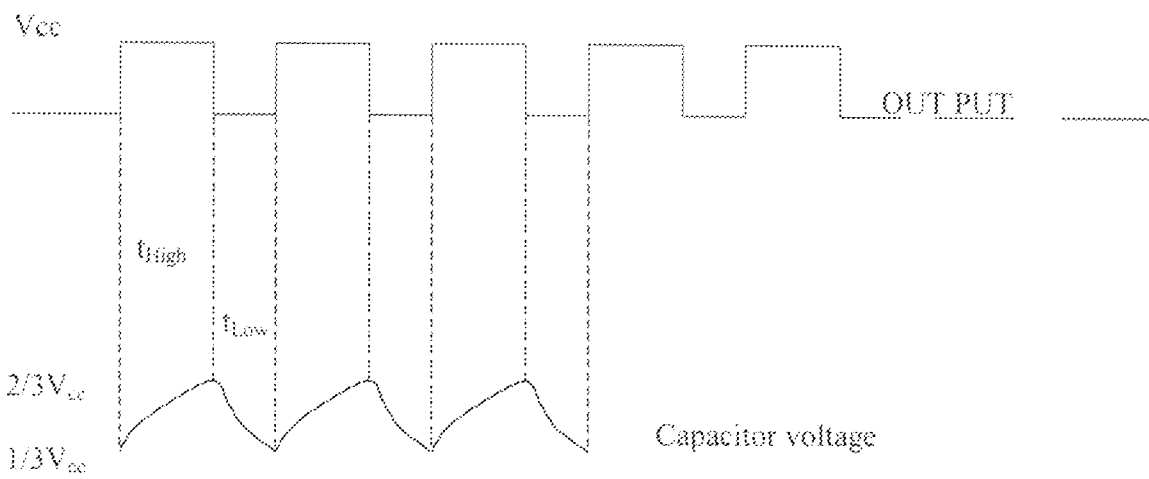

FIG 2.4 TIMING SEQUENCE OF ASTABLE MULTIVIBRATOR.

CALCULATIONS FOR THE 555 TIMER.

A frequency of 40KHZ is needed for this project.

$$F = \frac{1}{T} = \frac{1.45}{(RA + 2RB) C}$$

The minimum value of RA is approximately equal to $V_{cc}/0.2A$

But $V_{cc} = 9V$

$$\text{Minimum value of } RA = 9/0.2 = 45\Omega$$

Taking $RA = 150\Omega$

$$F = \frac{1.45}{C(150 + 2RB)}$$

Taking $C = 0.01\mu F$

$$40,000 = \frac{1.45}{0.01 \times 10^{-6} (150 + 2RB)}$$

$$40,000 = \frac{1.45}{(1.5 \times 10^{-6} + 2 \times 10^{-8} RB)}$$

$$40,000 (1.5 \times 10^{-6} + 2 \times 10^{-8} RB) = 1.45$$

$$6 \times 10^{-2} + 8 \times 10^{-4} RB = 1.45$$

$$8 \times 10^{-4} RB = 1.45 - 6 \times 10^{-2}$$

$$8 \times 10^{-4} RB = 1.39$$

$$RB = \frac{1.39}{8 \times 10^{-4}}$$

$$RB = 1737.5$$

$$RB \approx 1738\Omega$$

2.4 OPERATING FREQUENCY OF ULTRASONIC TRANSDUCERS

The operating frequency of ultrasonic transducers varies from 8KHz to a little over 200KHz or from 4.3cm to 0.18cm in wavelength. The transducers used for this project has an operating frequency of 40KHz for both the transmitter and the receiver.

In high-power applications lower frequencies are used because of absorption in air.

Devices that have higher frequency are more compact, produce narrower beam and higher resolution and are good for short-range application where absorption is not a problem.

2.5 THE RECEIVER CIRCUIT.

The receiver circuit consists of the sensor (ultrasonic receiver) a filter, an AC amplifier, a comparator, a tone generator and the alarm.

2.6 THE FILTER.[1]

A frequency selective circuit that passes signals of specified band of frequencies and attenuates the signals of frequencies outside the band is called an electric filter. Filters may be analog or digital, for this project an analog filter is used.

The simplest way to make a filter is by using passive components (resistor, capacitors and inductors). This works well for high frequencies i.e. radio frequencies and ultrasonic. However at audio frequencies, inductors become problematic, as the inductors become large, heavy and expensive.

The active filter overcomes the aforementioned problems of passive filters. They use op – amp as active elements and resistors and capacitors as passive elements. The active filters by enclosing a capacitor in the fed back loop avoid using inductors.

The active filters have their limitation too. High frequency response is limited by the gain – bandwidth (GBW) product and slew rate of the op – amp. Moreover the high frequency active filters are more expensive than passive filters. The passive filter in high frequency range is a more economic choice for applications.

The most commonly used filters are:

Low Pass Filter (LPF)

High Pass Filter (HPF)

Band Pass Filter (BPF)

Band Reject Filter (also called Band Stop Filter) (BSF)

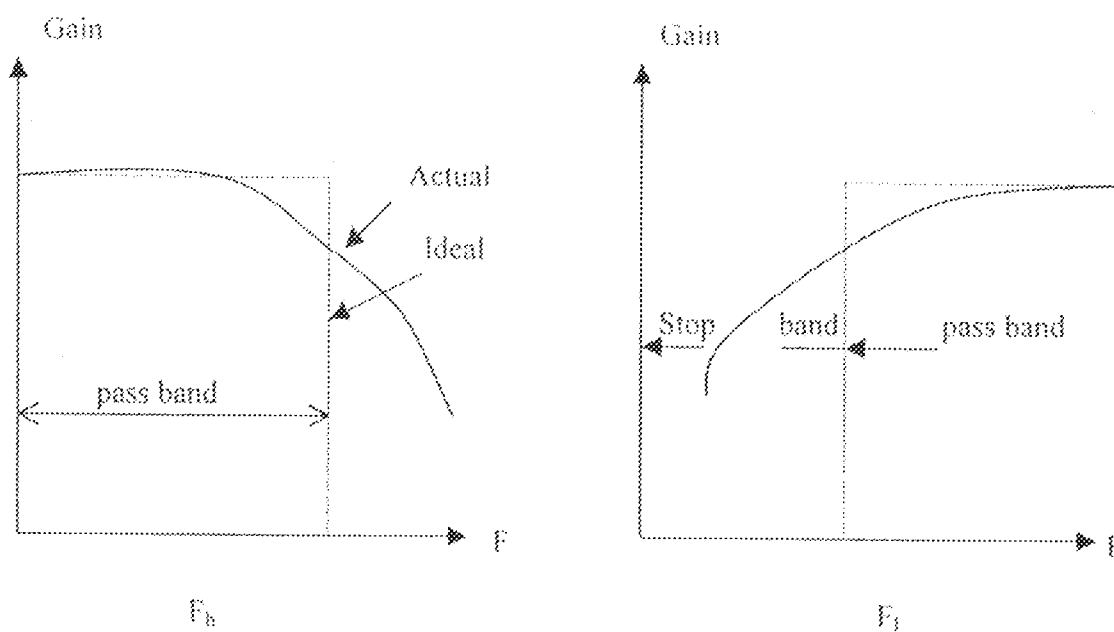

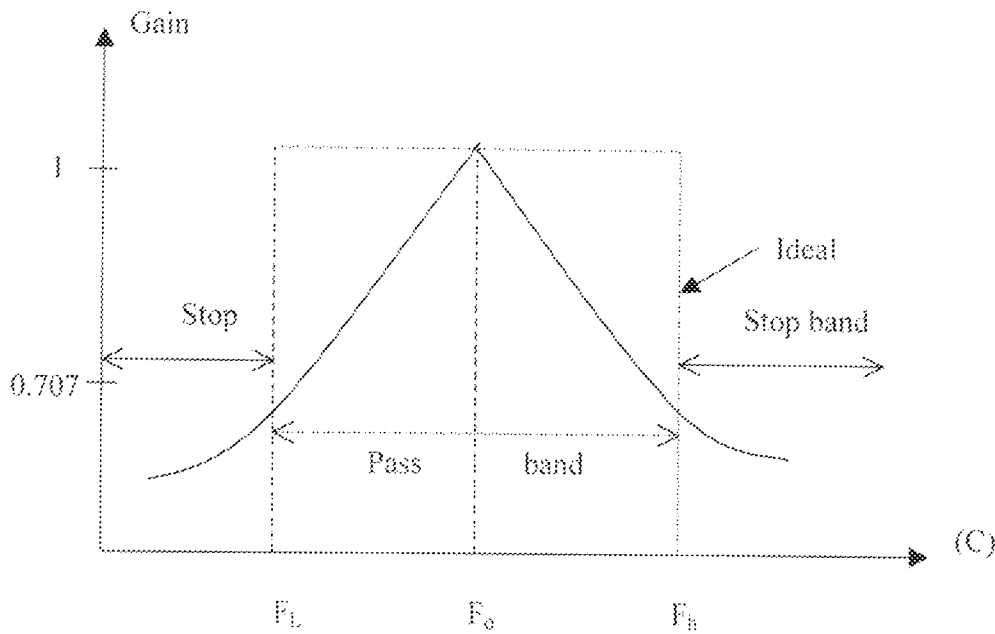

FIGURE 2.5 FREQUENCY RESPONSE OF SOME COMMONLY USED FILTERS.

- (A) LOW-PASS
- (B) HIGH-PASS
- (C) BAND-PASS

On the diagrams the dashed curves indicates the ideal response and solid curves shows the practical filter.

FILTER CALCULATION

If a.c. amplifier gain = 4.1889

The input impedance of the amplifier is given as

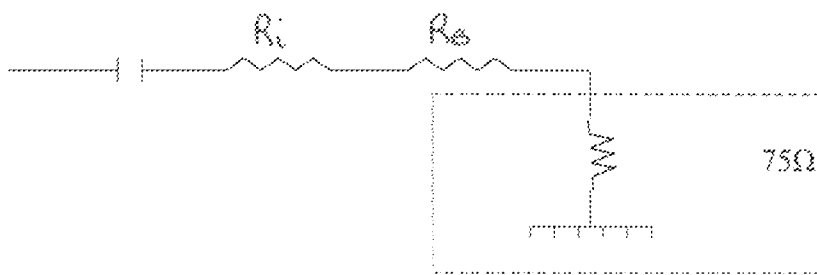

$$Z_{in} = \frac{1}{sC_1} + R_i + R_B + 75\Omega$$

But $4.1889 = \frac{R_B}{R_i}$

$$Z_{in} = \frac{1}{sC_1} + R_i + 4.189R_i + 75 \leq 1M\Omega$$

$$\frac{1}{s} = \frac{1}{j\omega} = \frac{1}{2\pi f} = \frac{1}{2 \times 22 \times 40 \times 10^3} = 3.9788 \mu\text{sec/rad.}$$

If C_1 is $0.1 \mu\text{f}$ the $Z_{c1} = 39.7j\Omega$.

Which quite low for the ultrasonic frequency diagram (a)

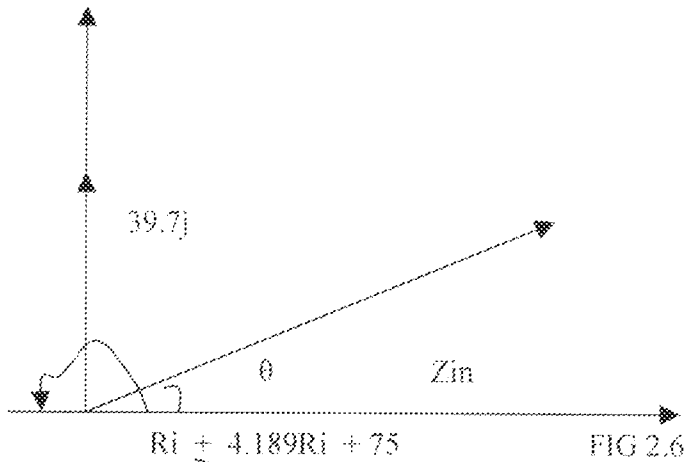

$$\theta = \tan^{-1} \left(\frac{39.7}{R_i + 4.189R_i + 75} \right) \rightarrow \text{phase shift}$$

$$R_i + 4.189R_i + 75 \gg 39.7\Omega$$

If $4.189R_i = 5k\Omega$

Then $R_i = 5 \times 10^3$

$$4.189$$

$$R_i = 1193.6$$

$$R_i \approx 1.2\text{k}\Omega$$

$$\text{But } 4.189 = R_B$$

$$R_i$$

$$4.189 = R_B$$

$$1.2\text{k}$$

$$R_B = 4.189 \times 1.2\text{k}\Omega$$

$$R_B = 5.0268$$

$$R_B \approx 5\text{k}\Omega$$

$$\theta = \tan^{-1} \left(\frac{39.7}{1.2\text{k} + 5\text{k} + 75} \right)$$

$$\theta = \tan^{-1} 0.006327$$

$$\theta = 0.362^\circ$$

Amplifier input impedance

From the diagram (a) above

$$\tan \theta = \frac{Z_{in}}{6275}$$

$$0.362^\circ = \frac{Z_{in}}{6275}$$

$$Z_{in} = 0.362^\circ \times 6275$$

$$Z_{in} = (2271.6 - 39.7)\Omega$$

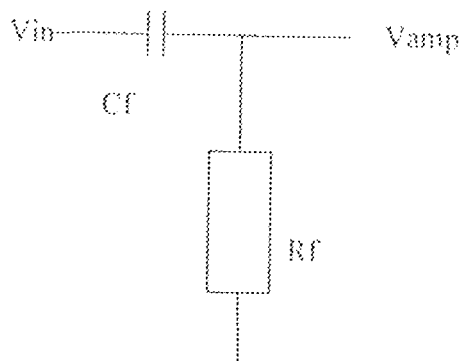

But $\frac{V_{amp}}{V_{in}} = \frac{R_f}{1/sCf + R_f}$ but this is on no loading

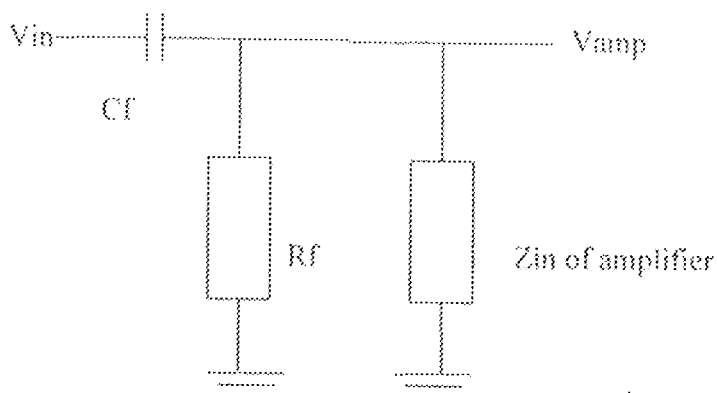

Fig 2.7

$$\frac{V_{amp}}{V_{in}} = \frac{R_f // Z_{in}}{1/sCf + (R_f // Z_{in})} = \frac{K_1}{1/sCf + K_1}$$

As $S \rightarrow \infty$ Transfer function = 1

As $S \rightarrow 0$ Transfer function = 0

Dc has $S = 0 \Rightarrow$ Dc cannot pass.

Noise of band width (B.W) 20KHZ

$$S = 2\pi f$$

$$S = 2\pi \times 20 \times 10^3$$

$$= 125663.7 \text{ rad/sec.}$$

New Transfer function = 0.707 T.F at diminishing point

$$\text{New TzF} = \frac{\text{T.F}}{2}$$

2

$$\Delta \text{T.F.} = \frac{1}{2} \text{T.F.}$$

2

$$\text{if T.F.} = > 0.707 = \left[\frac{R_F \cdot Z_{in}}{R_F + Z_{in}} \right]$$

$$\frac{1}{2} \left\{ \left[\frac{1}{125663.7CF} \right] + \left[\frac{R_F \cdot Z_{in}}{R_F + Z_{in}} \right] \right\} = \left[\frac{R_F \cdot Z_{in}}{R_F + Z_{in}} \right]$$

$$\left[\frac{1 + R_F Z_{in} (125663.7 CF)}{R_F + Z_{in}} \right] = \frac{2 R_F Z_{in}}{R_F + Z_{in}}$$

$$R_F + Z_{in} + R_F \cdot Z_{in} (125663.7 CF) = 2 R_F Z_{in}$$

$$Z_{in} + R_f (1 + 125663.7 C_f Z_{in} - 2 Z_{in}) = - Z_{in}$$

$$R_f = \frac{2271.6 - 39.7j}{(2 - 125663.7 C_f) (2271.6 - 39.7j) - 1}$$

$$R_f = 52.2\Omega \quad C_f = 11.1\mu F$$

2.7 AC AMPLIFIER.[1.3]

The output from the ultrasonic receiver through the filter is a low-level pulse waveform. It cannot properly be detected and therefore needs to be amplified. There are different forms of amplifier circuits; the inverting and non-inverting operational amplifier configurations respond to both ac and dc signals. However, if one wants to get the ac frequency response of an op-amp or if the ac input signal is super imposed with dc level it becomes essential to block the dc component. This is achieved by using an ac amplifier with a coupling capacitor. Ac amplifiers are of inverting and non-inverting. For this project the inverting Ac is used.

The circuit shown below shows an inverting ac amplifier.

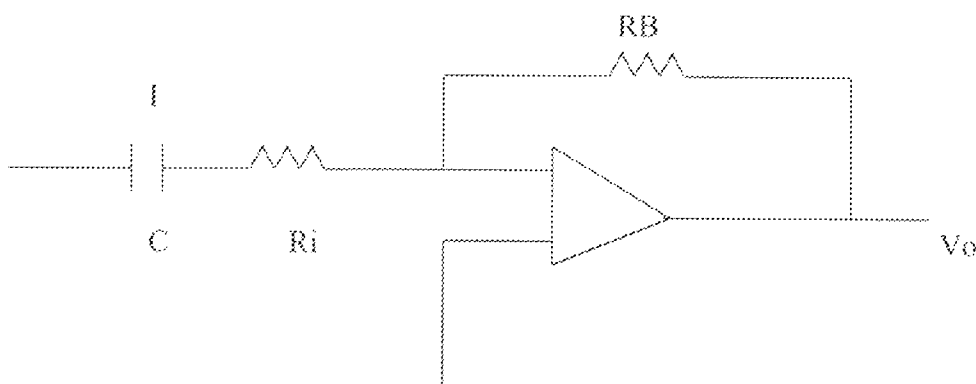

Fig 2-8

The capacitor C blocks the dc component of the input and together with the resistor R1 sets the lower 3dB frequency of the amplifier.

Since node 'a' is at virtual ground, the output voltage Vo is given by;

$$V_o = -I_{RB} = \frac{V_i}{R_i + 1/sC} \cdot R_B \dots\dots\dots(i)$$

Therefore

$$A_{cl} = \frac{V_o}{V_i} = - \frac{R_B}{R_i} \left(\frac{s}{s + (1/R_i)C} \right) \dots\dots\dots(ii)$$

It is seen from equation (ii) above that the lower 3dB frequency is

$$f_L = \frac{1}{2\pi R_i C}$$

In the mid – band range of frequencies, capacitor C behave as a short circuit and therefore, equation (ii) becomes;

$$A_{CL} = - \frac{R_B}{R_i}$$

For this project the output voltage was found to be 1.8V which was very small for it to be noticed because of this the amplifier circuit “LM 358” which some selected values of external resistance in the ranges of 1kΩ to 100kΩ, such that a specific gain is achieved. After amplification it was noticed that an output of 8.4 volt was obtained, which is large enough for a noticeable output.

CALCULATIONS FOR SIGNAL AMPLIFIER

$$\begin{aligned}ACL &= -\frac{R_B}{R_i} \\ &= -\frac{5K}{1.2K} \\ &= -4.167\end{aligned}$$

The voltage gain with feed back

$$AV = \frac{V_o}{V_{in}} = -\frac{R_B}{R_i}$$

$$\Rightarrow V_o = \frac{R_B}{R_i} V_{in}$$

$$V_{in} = 1.8V \left[\begin{array}{c} R_i \\ \end{array} \right]$$

$$R_i = 1.2K$$

$$R_B = 5K\Omega$$

$$V_o = \left[\frac{-5K}{1.2K} \right] 1.8$$

$$= -4.167 \times 1.8$$

$$= -7.5\text{Volt}$$

The negative sign implies an inversion of the output with respect to the input.

Current into the signal amplifier

$$I_{in} = \frac{V_{in}}{R_i}$$

$$= \frac{1.8}{1.2K\Omega}$$

$$= 1.5\text{mA}$$

$$= 1.5\text{mA}$$

The net loop gain for the inverting circuit

$$\beta = \frac{R_i}{R_i + R_B}$$
$$= \frac{1.2K}{1.2K + 5K}$$
$$\beta = 193.55$$

$$A\beta = \frac{A R_i}{R_i + R_B}$$
$$= \frac{(-4.16A) 1.2K}{1.2K + 5K}$$
$$= -0.81$$

The resistor R_i into the amplifier

$$R_{IN} = \frac{V_{IN}}{I_{in}}$$
$$= \frac{1.8}{1.5}$$
$$1.2K\Omega$$

2. 8 SIGNAL COMPARATOR. [1,3]

The next stage after the signal amplifier is the signal comparator, the output of the ac amplifier is feed into the comparator. A comparator is a circuit, which compares a signal voltage applied at one input of an operational amplifier with a known reference voltage at the other input. It is basically an open-loop operational-amplifier with output π

V_{sat} (V_{cc}) as shown in the ideal transfer characteristics of figure 2.9 (a). However a commercial op-amp has the transfer characteristic of figure 2.9 (b) as shown below:

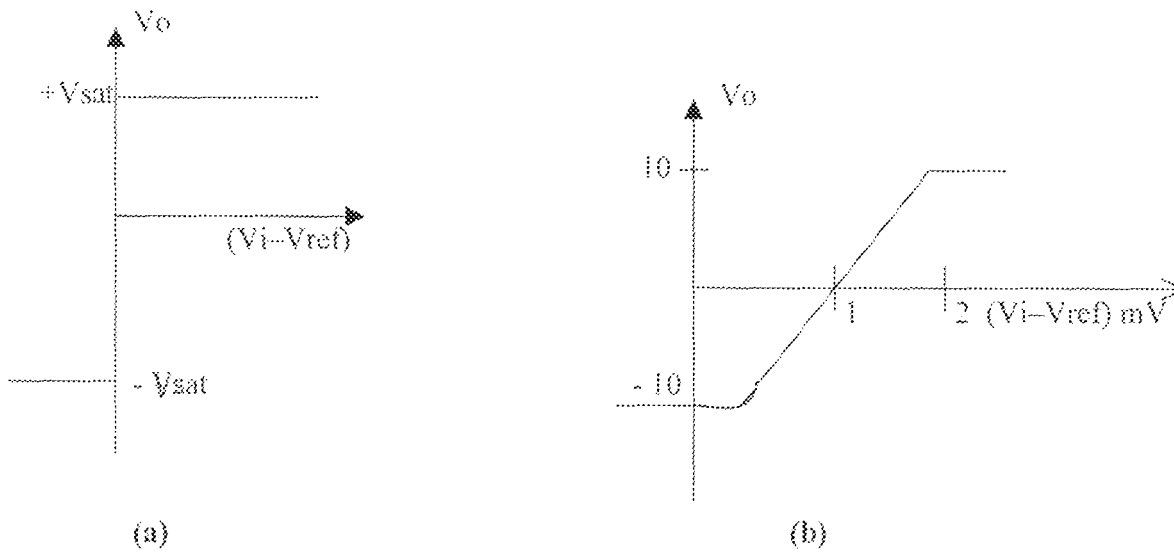

Figure 2.9 The transfer characteristics

- (a) Ideal comparator
- (b) Practical comparator.

There are basically two types of comparators: -

- (a) (i) Non-inverting comparator
- (ii) Inverting comparator
- (b) Practical comparator: - comparators are used as key element of analog-to-digit and digit-to-analog conversion system.

The circuit below shows a practical inverting comparator in which the reference voltage V_{ref} is applied to the non-inverting (+) input and V_i is applied to the inverting (-) input. For sinusoidal input the output waveform is also shown in figure 2.3.3.1 below and for V_{ref} positive and negative respectively.

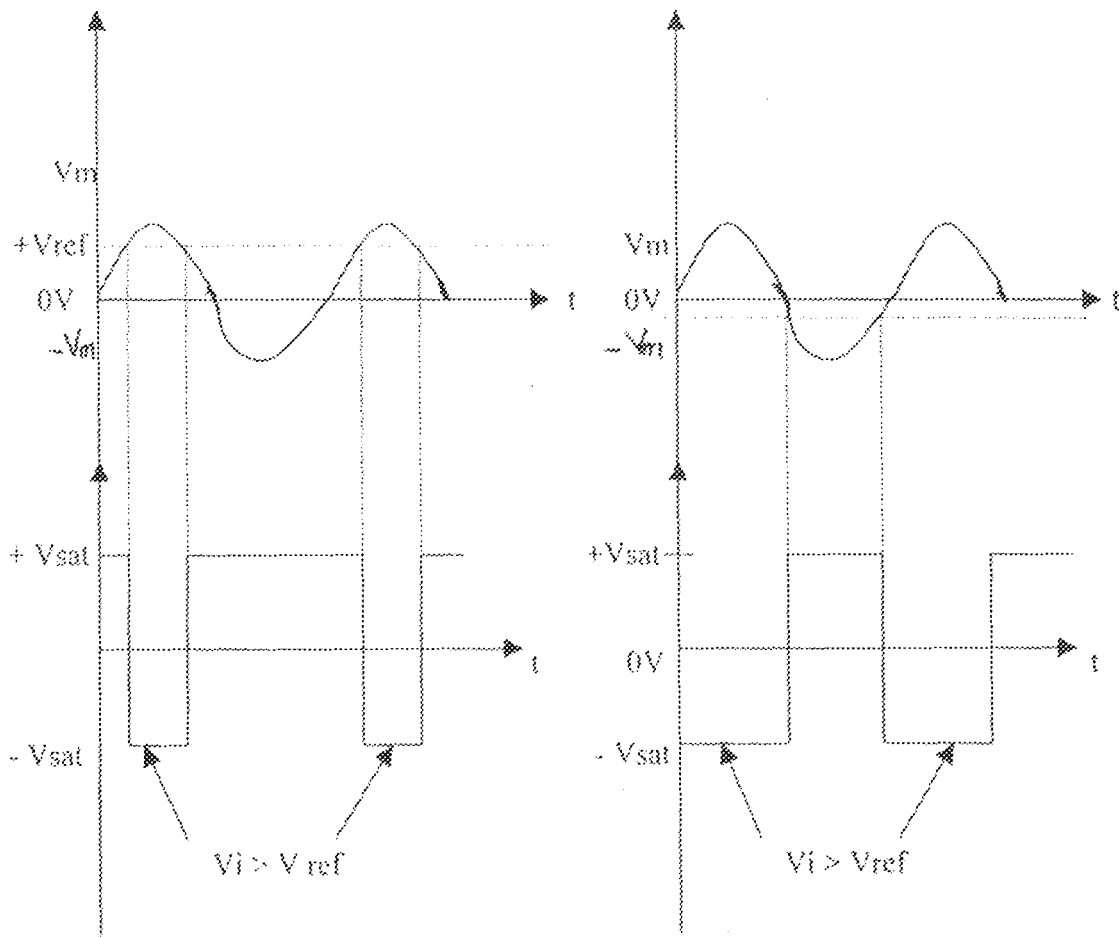
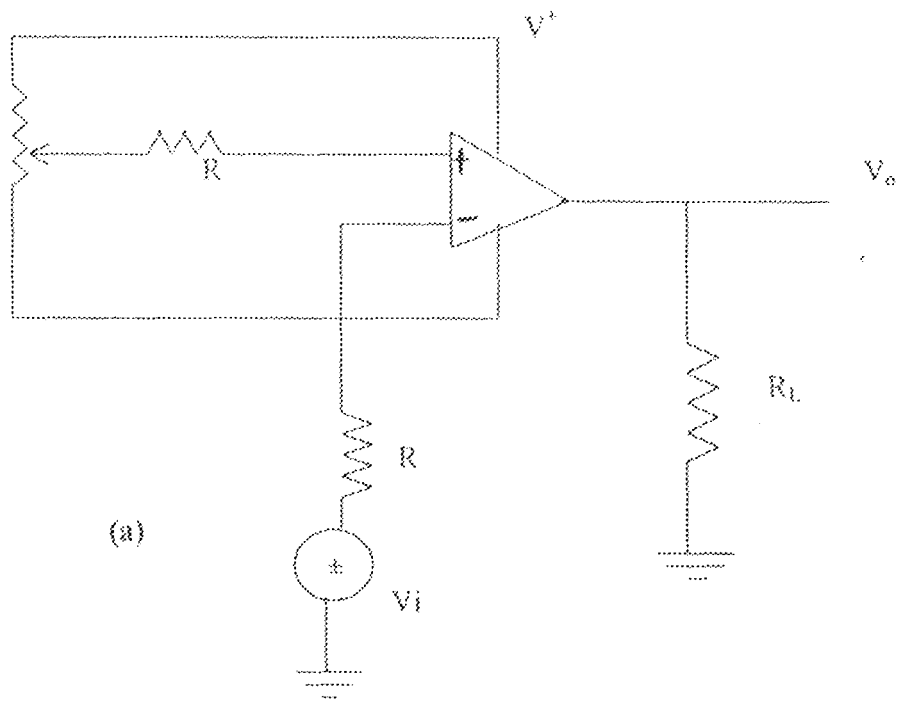

- FIGURE 2.10 (a) Inverting comparator. Input and output waveforms
- (b) $V_{ref} > 0$
- (c) $V_{ref} < 0$

As earlier stated the regenerative comparator (Schmitt-trigger) is used for this project. This is done by the addition of positive feedback to the comparator circuit, which increases the gain greatly. Theoretically, if the loop gain - $\beta A_o L$ is adjusted to unity (one), then the gain with feed back, A_{vf} becomes infinite. However it may not be possible to maintain loop-gain exactly equal to unity for a long time in practical circuits because of supply voltage and temperature variations, so a value greater than unity is chosen.

Figure 2.11 shows a regenerative comparator. This circuit is also known as Schmitt-trigger. The input is applied to the inverting (-) input terminal and the feed back voltage is applied to the non-inverting (+) input terminal.

The input voltage V_i triggers the output V_o every time it exceeds certain voltage levels. These voltage levels are called UPPER THRESHOLD voltage (V_{UT}) and LOWER THRESHOLD voltage (V_{LT}). The hysteresis width is the difference between these two-threshold voltages ie

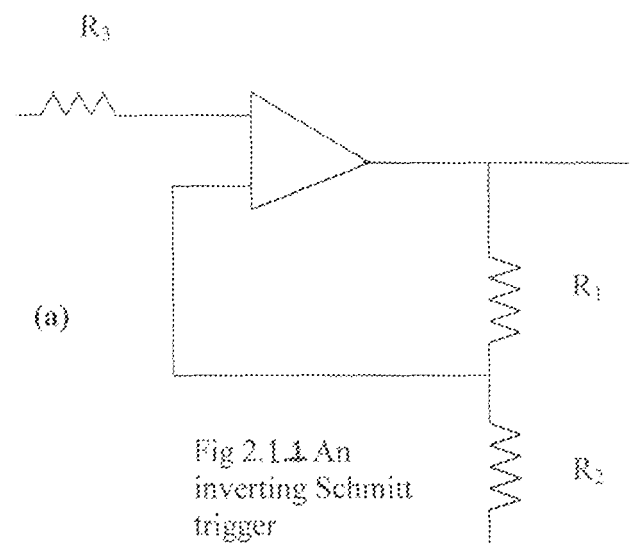
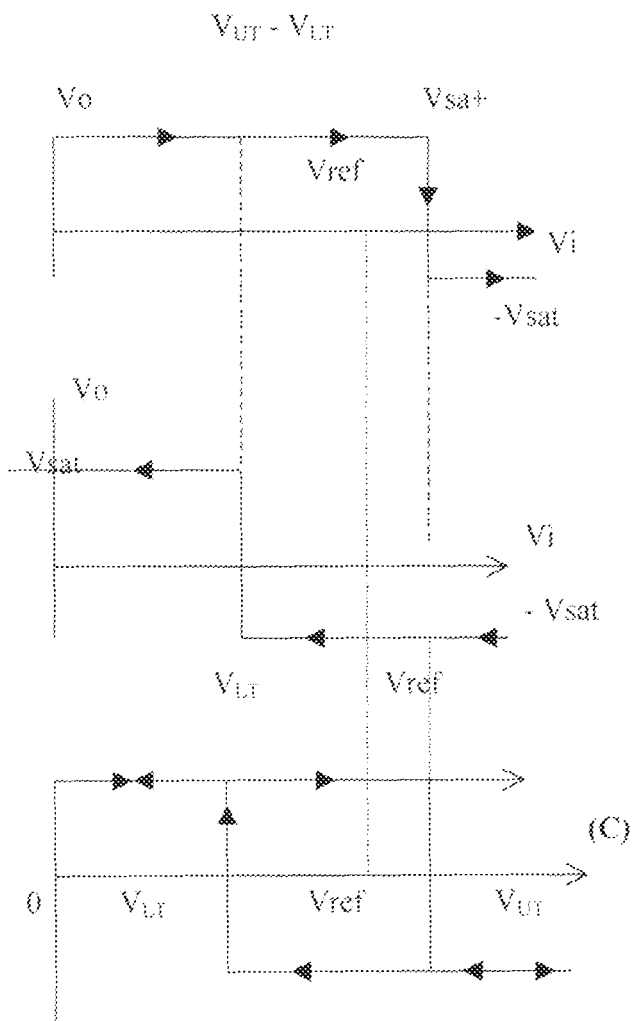

Fig 2.1.1 An inverting Schmitt trigger

FIG 2.1.2

- (a) Transfer characteristic of a schmitt trigger for V_i increasing
- (b) V_i decreasing

SIGNAL COMPARATOR CALCULATIONS:

Let Amplifier gain be high generally.

The minimum voltage to trigger the Schmitt trigger is

$$\frac{V_o \Phi R7}{\Phi R7 + R6} + \frac{VCC \Phi R7}{R7 + R8} + Vfd \text{ of rectifier}$$

For a low threshold voltage so that design of amplifier gain will be of greater freedom. The germanium diode is used so as to use $\approx 0.2V$ if Φ is the ratio got by turning variable resistor clockwise or anticlockwise. The angle allows is a maximum of 240° .

$$\Phi = \frac{\theta}{240} \text{ for linear variable resistors } \theta = \text{the angle}$$

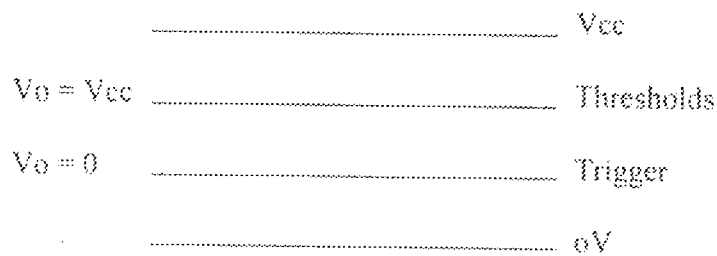

$$\frac{V_{\text{Trigger}} + V_{\text{Threshold}}}{2} = \frac{V_{\text{cc}}}{2}$$

$$R_7 = R_8 = 10K\Omega$$

$$0 < \text{input impedance} < \infty$$

$1M\Omega < \text{really input impedance} < 2M\Omega$ for 358/741/324.

The thevenin voltage is not affected by the op-amp's impedance. To keep errors of loading within 5% - 10%

$$\text{Trigger voltage} = \frac{V_{\text{cc}} (R_7 // R_6)}{R_6 // R_7 + R_8} + \frac{(R_8 // R_7) V_o}{R_8 // R_7 + R_o}$$

$$V_{\text{trigger}} = \frac{9 (10 \times 10^3 // R_6)}{(10 \times 10^3 // R_6) + 10 \times 10^3}$$

Voltage greater than or equal to $V_{\text{trigger}} + 0.2V$ should be provided by the transmission.

Let V_{trigger} be 1 volt

Peak value of amplifier should not drop below 1.2V if not the alarm will ring.

$$1 = \frac{\left(\frac{10 \times 10^3 R_6}{10 \times 10^3 + R_6} \right) \cdot 9}{\frac{10 \times 10^3 R_6}{10 \times 10^3 + R_6} + 10 \times 10^3 (10 \times 10^3 + R_6)}$$

$$(10 \times 10^3 R_6) + (10 \times 10^3) \times (10 \times 10^3) + 10 \times 10^3 R_6 = 9 \times 10 \times 10^3 R_6$$

$$10 \times 10^3 R_6 (1 - 9 + 1) = (-10 \times 10^3)^2$$

$$7 \times 10 \times 10^3 R_6 = (10 \times 10^3)^2$$

$$70 \times 10^3 R_6 = 100 \times 10^6$$

$$R_6 = \frac{(100 \times 10^6)}{70 \times 10^3}$$

$$R_6 = 14285 \mu\Omega$$

$$R_6 \approx 1.5 \text{K}\Omega$$

For threshold voltages the reset switch can handle that efficiently.

FOR HALF WAVE RECTIFICATION

$$\frac{V_m}{\pi} = V_{dc} + 0.2$$

$$V_m = \pi V_{dc} + 0.2\pi$$

$$= (1 + 0.2)\pi$$

$$V_p = 3.769 \text{ Volts}$$

$$V_{\text{peak-peak}} = 2VP = 7.539 \approx 7.54V$$

$$\text{i.e. } \frac{7.54}{9} = 0.8377.$$

about 83.78%

$$\text{AC amplifier gain, } AV \cong \frac{83.7\% V_{cc}}{1.8V} = 4.1889$$

Where 1.8V is the output voltage of the ultrasonic receiver.

2.9 TONE GENERATOR

In figure 2.1.3 the 555 timer is connected by the output of the comparator to give an audible tone. The 555 timer is controlled by an external capacitor and resistor network to obtain a frequency of and with the proper selection of this resistors and capacitors, a time

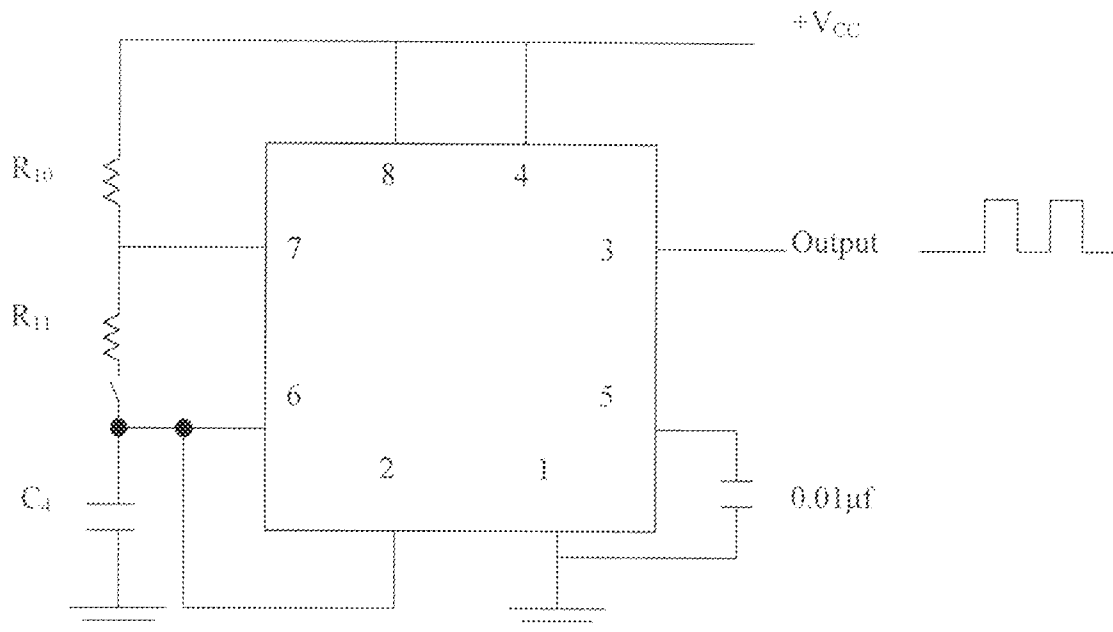

FIGURE 2.1.3 555 TIMER AS A TONE GENERATOR

The frequency from the tone generator is feed into 5W speaker to be able to obtain an audible alarm whenever the inaudible ultra-sound is interrupted. The audible frequency for human hearing range between 6Hz – 20KHz and by having a frequency of from the output of the tone generator an audible sound is received through the speaker.

CALCULATIONS FOR TONE GENERATOR.

$$\begin{aligned}
 t_1 &= 0.693 (R_0 + R_{11}) C_4 \\
 &= 0.693 (1 \times 10^3 + 4.7k) 0.022 \mu F \\
 &= 696257.1 \times 0.022 \times 10^{-6} \\
 &= 0.0153176 \\
 &= 15.318 \text{mSec} \\
 t_2 &= 0.693 (R_{11}) C_4 \\
 &= 0.693 (4.7K) 0.022 \times 10^{-6} \\
 &= 0.000071656 \\
 &= 0.07166 \text{mSec} \\
 T &= t_1 + t_2 \\
 &= 0.693 (R_0 + 2R_{11}) C_4 \\
 &= 0.693 (1 \times 10^3 + 2(4.7K)) 0.022 \times 10^{-6} \\
 &= 0.693 (1009400) 0.002 \times 10^{-6} \\
 &= 0.015389 \\
 &= 15.389 \text{mSec} \\
 \text{Duty ratio} &= \frac{R_{10}}{R_{10} + 2R_{11}} \times 100\%
 \end{aligned}$$

$$= \frac{4.7k}{4.7k + 2(4.7k)} \times 100$$

$$= \frac{4.7k}{14.1k} \times 100$$

$$= 33.3\%$$

Frequency of oscillation is given as

$$F = \frac{1}{T} = \frac{1.45}{(R_{10} + 2R_{11})C_4} = \frac{1.45}{14.1K \times 0.022 \times 10^{-6}}$$

$$= 4674.41HZ$$

$$= 4.6741HZ$$

2.10 ELECTRICAL CHARACTERISTICS OF ULTRASONIC TRANSDUCERS [9]

An ultrasonic transducer is a special device use in converting high acoustic wave into electrical signal. They can also be used to convert electrical signal into acoustic wave.

For this project, the following characteristics as specified by the manufacturer were considered for the proper functioning and efficiency of the transducer.

	SCG-40IT	SCM-40IR
	Transmitter	Receiver
Sensitivity	106dB	-65dB
Resonant frequency	40±1KHz	40±1KHz
Pulse rise time	2msec	0.5msec

Maximum input voltage	20Vrms	_____
Impedance	500Ω	30KΩ
Operating Temperature	-20 ⁰ C to +60 ⁰ C	-20 ⁰ C to +60 ⁰ C
Capacitance	1100PF	1100PF

The operating distance and the direction angle are 5meters and 30⁰ respectively.

2.11 THE POWER SUPPLY UNIT.

Most electronic system and circuits requires a d.c source for their operation. Dry cells and batteries are one form of d.c source. They have the advantages of being portable and ripple free. However, their voltage are low, they need frequent replacement and are expensive compared to conventional d.c power supplies. Since the most convenient and economical source of to convert this domestic A.c supply. It is advantageous to convert this alternating voltage to d.c voltage. It is accomplished with the help of

- i. RECTIFIER
- ii. FILTER
- iii. VOLTAGE REGULATOR CIRCUIT

The components when coupled together will constitute the d.c power supply.

Figure 2.14 shows the block schematic diagram of a power supply unit

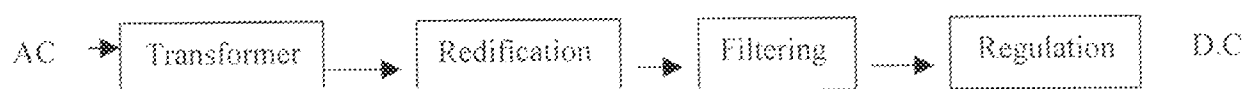

Fig 2.14 BLOCK DIAGRAM OF A POWER SUPPLY UNIT.

TRANSFORMER: The transformer reduces the incoming voltage to the require voltage

RECTIFICATION: This can be defined as the process of obtaining Uni-directional currents and voltages from alternating current and voltages. In the design, of the power supply unit for this project, a bridge rectifier was used.

FILTER: Although the output of the A.C to pulse D.C converter is of single polarity, the changes in level are still undesirable. To operate electronic equipment, the D.C must be of constant level. This process of maintaining level is called "filtering".

A capacitive type of low filter is the most widely used. The charging and discharging of the capacitor in the filter is designed so that it is capable of maintaining a relatively constant level as the input to the filter varies. For this project however a smoothening capacitor (2200 μ F) is used.

REGULATION: From the filter, an optional step to take is to provide regulation. This maintains constant output under various load conditions. A special form of diode called zener diode can be used for simple regulation. Voltage regulator ICs are also used. For this project the 7809 voltage regulator is used to provide protection against overloading and under loading of the circuit component.

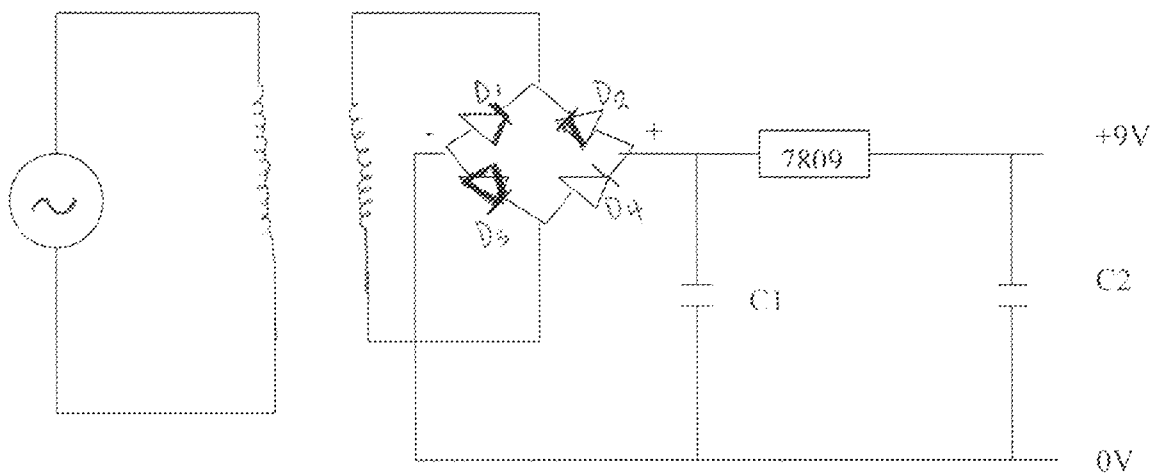

Fig. 2.1.5 Diagram For Power Supply Unit.

PART LIST FOR +9V POWER SUPPLY.

- IC₁ = 7809 + 9Vdc voltage regulator
- C₁ = 2200 micro -farad electrolytic 16V
- C₂ = 100 micro-fared electrolytic, 10V
- LED 1 = Light-emitting diode
- T₁ = 12 volts transformer.
- BR₁ = bridge rectifier.

CHAPTER THREE

3. 0 LAYOUT AND CONSTRUCTION

In the construction of each of the sections that make up the intruder detector, the design specifications were adhered to strictly except in area where non-availability of material components make it possible for slight modifications (changes of specifications).

Proper component layout was first carried out on paper thereby making fault identification very easy during construction proper.

3.1. MATRIX BOARD LAYOUT

The dimension and size and complexity of each component were taken into consideration so as to prevent the overcrowding of the components with a particular region or point on the vero board. The design was divided into two modules; consequently two vero boards were used during the construction.

MODULE 1:

This is shown on figure 3.1.1.1 and it comprises of the power supply unit, the pulse generator, and the transmitter transducer.

MODULE 2:

This second part is made up of the ultrasonic receiver, the filter, the a.c amplifier, the comparator and it contains two op-amps inside so the signal amplifier and the comparator were connected on one IC.

3. 2 CONSTRUCTION

The construction work proceeded after the component/circuit testing on the project/bread board as outlined on the paper in the matrix board layout of figures 3.1 and 3.2

The power supply unit was constructed as design with an LED connected at the output of the power supply to indicate that power is on when switched on. The 8-pin LM 555 timer IC in an astable mode was used to achieve a frequency of 40KHz.

Simplifying carefully planned the circuit, wiring, minimize errors, and thereby making troubleshooting easier. The overall circuit layout was parallel as much as possible for logic signal flow. These serves as help to anyone looking at the board to easily find sections of the circuit and trace signal through it.

All the ICs were laid in such a way that they point to the same direction to reduce the chance of some being put in keep track of pin numbers when you are wiring or troubleshooting.

The circuit was built section by section. As a result of this, before moving to the construction of next section, the previous section is tested and must be confirmed okay. Also various component leads were kept at a minimum to prevent accidental short-circuiting. Ic sockets were used so that any defective IC can be replaced without removing and often incorrectly replacing the wires. Capacitors and other components, like resistors were mounted with their colour codes reading from left to right or from top to bottom, so that it is easier to spot errors.

After the connection of each section, IC pins were checked each from pin 1 to the highest number of pin and back to pin 1. This is to make sure that every pin is accounted

for a connection to the proper point to point. While this seem laborious, the time spent in careful construction and checking is well repaid by having the circuit work the first time and also by having the components in a save condition.

The soldering was cautiously done so as to avoid short circuit or bridging of two points of different potentials on the vero board. Vero board scrappers were used to separate cases of accidental soldering with suckers. Extra care was taken when connecting the legs of ICs to power supply and ground. Using digital mutt meter various points expected to be at equal potentials were tested for continuity and clean cuts were made where necessary.

While soldering, the following were taken into consideration

- a) All soldering were made shinny rather than dull grey.
- b) Care was taken to ensure that the solder had flowed into a smooth paddle rather than formed into a round ball.
- c) All solder bridges (pieces of solder crossing copper traces) formed were broken with a soldering iron and scrappers.
- d) All excess solder were removed.

CHAPTER FOUR

4.0 TEST, MEASUREMENT AND PROBLEM ENCOUNTERED

4.1 TEST AND MEASUREMENTS:

After carefully wiring the circuit, checking component polarities and ICs layout, the various segments of the construction were separately tested for their workability.

The output at pin 3 of the 555 timer was tested with an oscilloscope to be a square wave as desired. After connecting the transducer to Pin 3 the input frequency of the transducer was also measured by connecting a digital multimeter to the legs of the transducer.

The output of the receiver was also tested before filtering on the oscilloscope and after filtering the traces of noise in the waveform reduced drastically. The output of the amplifier was rectified and the output of the a.c amplified was rectified and the output of the rectified was viewed on the oscilloscope and found to be a dc voltage. A LED was connected to this output, which came ON when the two transducers were faced one to another and goes OFF when they are turned from each other.

When the transducers faced each other, an object was placed in between then and this triggers the alarm or before the speaker was connected the LED on the receiver section goes OFF when the object was removed the LED comes ON again. This indicates there is transmission and reception.

After all the tests were carried out, the system was found to be very suitable for detecting all forms of intruder into a protected area and it could cover a distance of 3m to 4m (four metres).

4. 2 PROBLEMS ENCOUNTERED

The problems encountered in the execution of this project include the non-availability and high cost of the needed components. The transducers especially were very difficult to get since they are not being sold in Minna. It took me some months of waiting for orders which the dealers me themselves said was coming from abroad.

The transducers were very sensitive and problematic, at a point one was damaged and I have to order for a new one.

Lack of proper equipment to assist in easy construction.

Ultrasonic energy does not propagate in a well defined beam like infra-red or light from a spot light, but rather in a defused cone, more intensed at the centre and dropping off at the edges. These caused an initial problem in detection.

Noise due to soldered joint was also a problem because of its effect on the circuit.

CHAPTER FIVE

5.0 CONCLUSIONS AND RECOMMENDATIONS

5.1 CONCLUSIONS

It can be deduced from the foregoing report that the design of an ultrasonic intruder like any other electronic system needs careful planning and implementation. There are various intruder alarm systems but this particular one is unique because of its mode of operation- the means of intrusion detection to be precise. As earlier stated ultrasonic have a number of application but I decided to used it my own way to detect intrusion. It was really challenging and tasking because of its originality. To be frank and sincere it was not easy but I am happier now that my conception is a reality.

5 .2 RECOMMENDATIONS

This circuit if properly researched and developed will become a replacement for many alarm systems (intruder detectors) that are not "fool proof" because it has the tendency of being almost 100% 'Fool proof'

I therefore recommend that the department or the school Authority should embark on further development and commercialisation of this system.

I also recommend that the school should be more involved in students project work by giving them challenging and relevant topic and also giving them financial assistance or other wise when needed.

REFERENCES

- 1 D.ROY CHOUDHURY - LINEAR INTEGRATED CIRCUITS
SHAIL JAIN
- 2 S.N SEN - ACOUSTICS, WAVES AND OSCILLATIONS
JOHN WILEY & SONS. NEWYORK.
CHICHESTER. SINGAPORE
PAGE 126, 207
- 3 IDACHABA ANDREW ENEBI - DESIGN AND CONTRUCTION
OF INFRARED INTRUSION DETECTOR
(UNPUBLISHED)
- 4 USMAN ABRAHAM USMAN - DESIGN AND CONSTRCTION OF
PROXIMITY DETECTOR USING
ULTRASOUND. (UNPUBLISHED)
- 5 COLLIER'S ENCYCLOPEDIA, - MACMILLAN EDUCATION COMPANY
VOLUME 22 NEW YORK, 1981
PAGE -- 579
- 6 ENCYCLOPEDIA AMERICAN - GROLIER INCORPORATED,
VOLUME 27 1981.
PAGE 358.

- 6 ENCYCLOPEDIA AMERICAN - VOLUME 27, GROLIER INCORPORATED,
1981.
PAGE 358.
- 7 ENCYCLOPEDIA OF PHYSICAL SCIENCE & TECHNOLOGY - VOLUME 24
PAGE 164.
- 8 THE NEW ENCYCLOPEDIA KNOWLEDGE IN DEPTH -- VOLUME 30
PAGE 840
- 9 40KHZ ULTRASONIC TRANSDUCER MANURE

MODULE 1

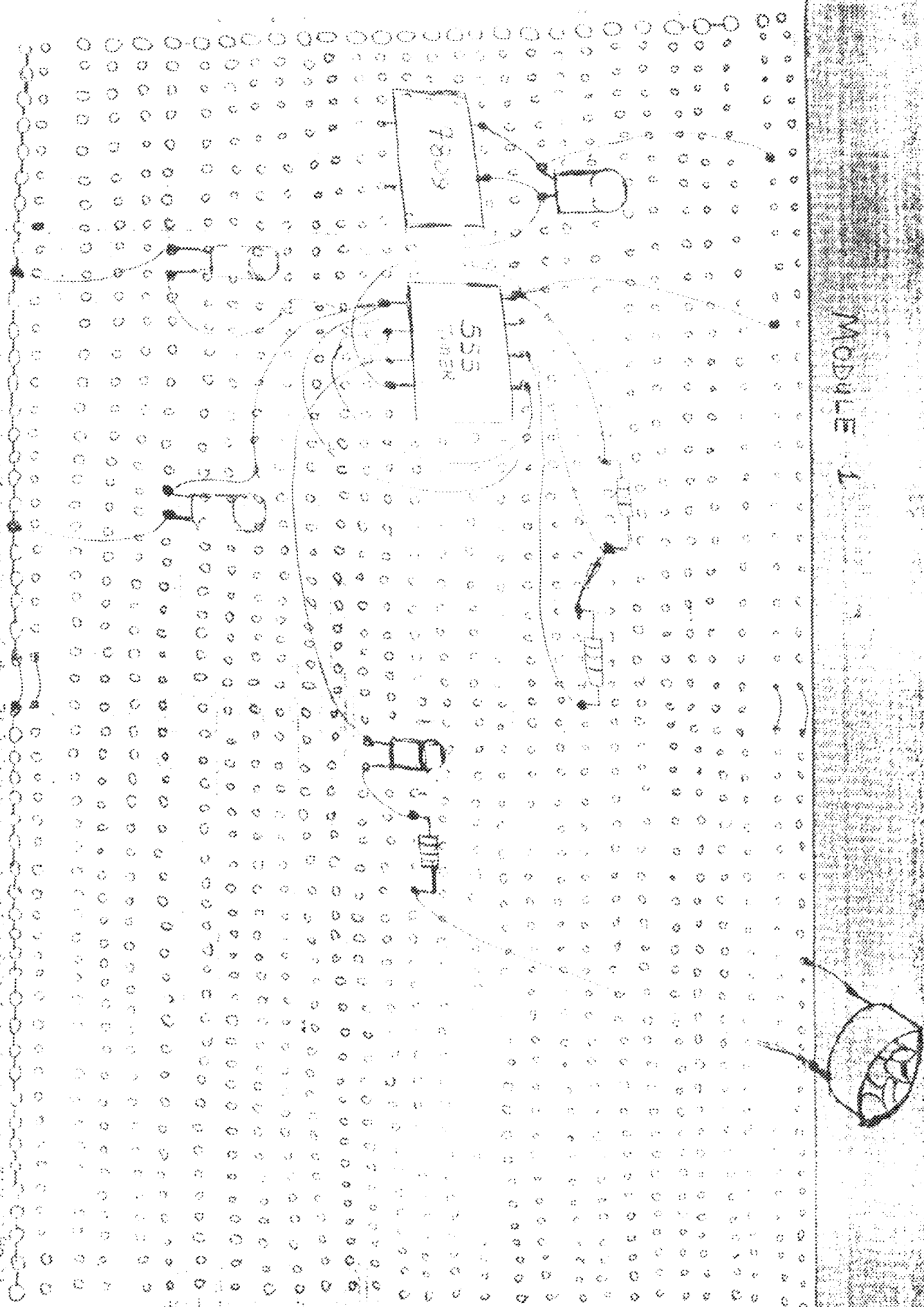

FIG 3.1



Module 2

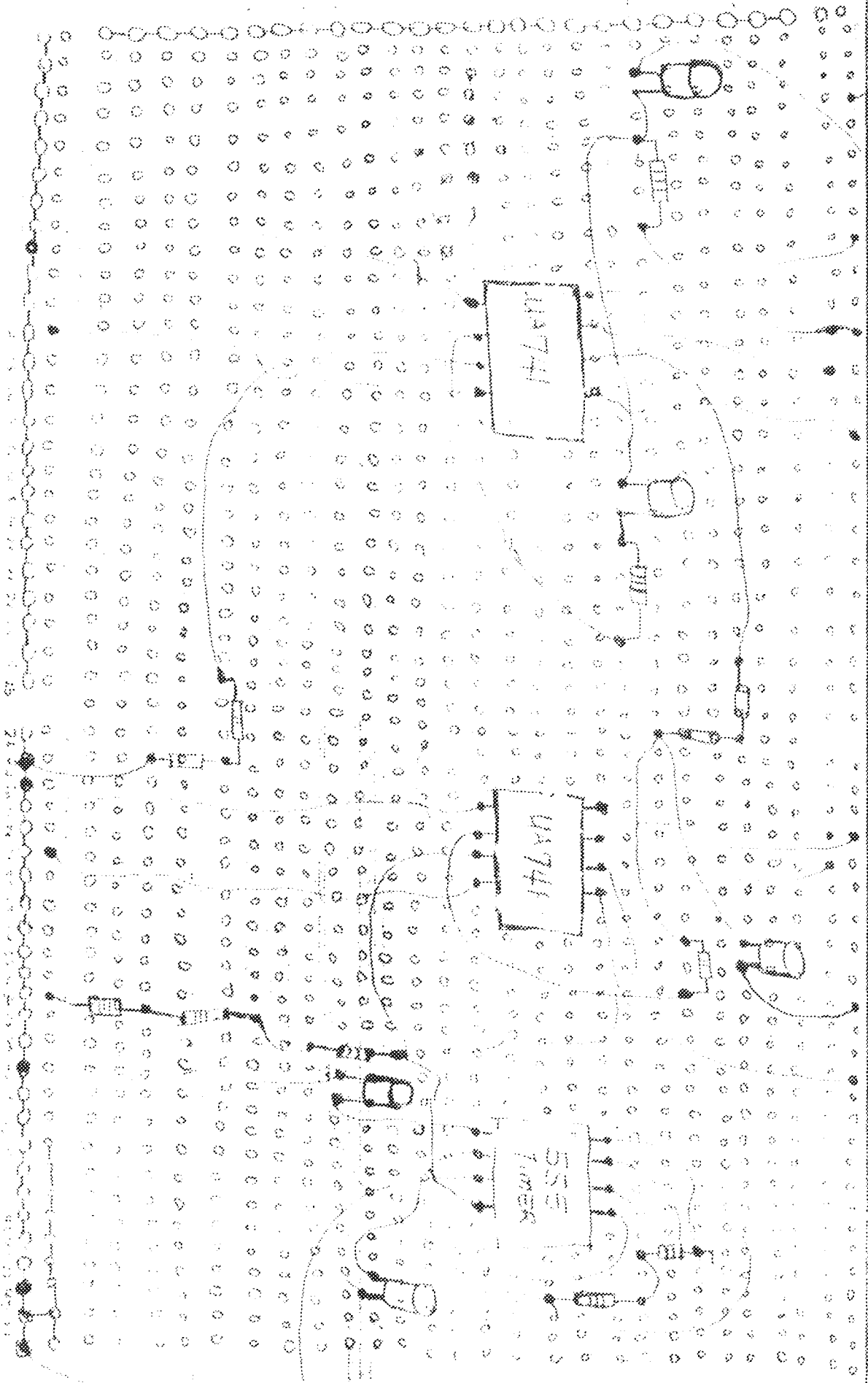

FIG 3.2

LIST OF COMPONENTS USED

COMPONENTS	VALUES
R ₁	150Ω
R ₂	1.8KΩ
R ₃	1KΩ
R ₄	1KΩ
R ₅	1KΩ
R ₆	15KΩ
R ₇	10KΩ
R ₈	10KΩ
R ₉	1KΩ
R ₁₀	4.7KΩ
R ₁₁	4.7KΩ
R ₁₂	5KΩ

CAPACITORS

C1	0.01μF
C2	0.1μF
C3	0.1μF
C4	0.022μF
C5	0.01μF
C6	0.1μF
C7	0.1μF
C8	0.1μF
C9	0.1μF

555 TIMER

LM 358

DIODE

TRANSDUCERS

Transmitter

Receiver

Ic sockets

Jumper Wires

Transformer

Switch

9V Regulator

SCS-40IT

SCM-40IR