

Cruise Control Using IMC and PID Controllers.

*Garuba Oluwatosin Rasheed¹, Taliha Abiodun Folorunso², Jibril Abdullahi Bala², Abdullahi Mohammad Ibrahim¹

¹Computer Engineering Department, Federal University of Technology, PMB 65 Minna Niger State, Nigeria

²Mechatronics Engineering Department, Federal University of Technology, PMB 65 Minna Niger State, Nigeria

*Corresponding author emails: ¹oluwatosin.pg2113148@futminna.edu.ng.

²funso.taliha@futminna.edu.ng.

ABSTRACT

The Proportional-Integral-Derivative known as (PID) controller has been continuously use in the modern industrial plant to control system due to its ease of tuning its parameters, though it is very time consuming and may be unreliable if efficiency parameters is not obtained. In this paper, we worked with the control of cruise system using PID and IMC controller tuned by Ziegler-Nichols techniques to compare the performance of the two different controller. The objective of this study is to evaluate the system's performance using the transient responses such as, rise time, settling time and steady-state. The simulation results show that the IMC controller gives a better transient response than the PID controller.

Keywords: *Cruise Control, Ziegler-Nichols, PID Controller (IMC) Internal Control Model.*

1 INTRODUCTION

The cruise control is a system that has recently been added as a function to help smart vehicles [1]. The system is a useful system which enable driver to relax when driving over a long distance. Many drivers gripe about having to quickly depress the gas pedal to keep the car moving, but the invention of cruise control has reduced the mental and physical strain of constantly monitoring the pace of the car [2]. Cruise control is an electronic system that will allow the driver to set vehicle at a constant speed, letting the driver to do away with pressing the accelerator pedal [2].

A most typical controller for operating the cruise control for optimal control is the proportional-integral-derivative (PID) controller [1]. Other alternatives include the fuzzy logic approach etc [3]. The PID controller is quite common in the control system owing to its efficiency, dependability, simplicity of design, and ease of tuning [4]. PID controller parameters are proportional gain K_p , integral gain K_i as well as derivative gain K_d which are required to be tuned optimally in order to achieve efficient control of the system. There are various method of turning the parameters which include Pole placement, Cohen-coon, Ziegler-Nichols, Internal Model Control (IMC) methods etc. [1], [4] – [8].

Achieving optimal turning using the various methods or techniques of turning PID controller for any particular system depends on the feasibility of the techniques in response to the system [4]. The efficiency of the controller depends on the efficacy of the tuning methods used to obtain the PID

controller parameter. Hence, in this work we employ the performance of PID tuned using Ziegler-Nichols method as well as IMC controller in controlling the cruise system.

The remaining part of this paper is divided into three sections: section 2 the methodology- focusing on system design, and controller designs while section 3 focuses on the results, and section 4 the conclusion of the work.

2 THE CRUISE CONTROL SYSTEM DESCRIPTION

The controller takes driver's signal as the reference input speed signal, sends it to the system, and evaluates the car speedometer's output. The two signals, the cruise control and the turn signal, ensure that the vehicle's speed is consistent.

The cruise system can do this by altering the engine's driving force by modulating the throttle angle, or "u." [8]. Figure 1 shows the cruise system block diagram showing different parts of it operations.

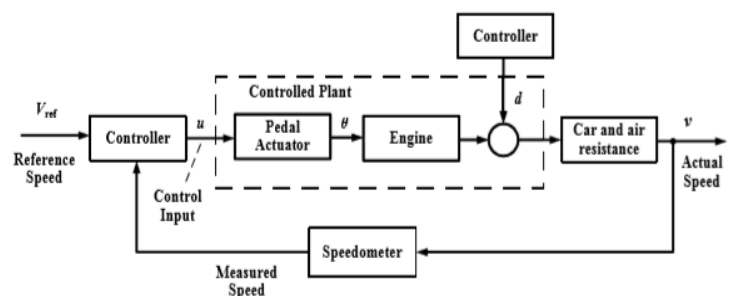

Figure 1. Block diagram showing details of operation for the cruise system

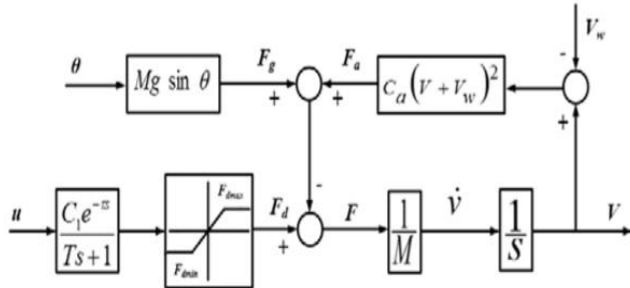

Figure 2. Vehicle Dynamic

The vehicle dynamics shows the system has a non-linear characteristics [8].

2. MATHEMATICAL MODELLING FOR CRUISE CONTROL SYSTEM

The mathematical formulation and features according to the cruise system based on non-linear can be obtained as follows, in accordance with Newton's first law of motion (1).

$$\sum F = m * a \quad (1)$$

Where m = mass of the passengers and the car and a = acceleration. In (1), which sums all forces acting on the car. Consequently, equation (2) can be used to express the total force.

$$\sum F = F_d - F_a - F_g \quad (2)$$

The forces F_d , F_a and F_g represent the engine drive force of the vehicle, aerodynamic drag force, and frictional and gravitational force acting on the vehicle respectively. Each of the forces can be represented as the following [8]. (3) – (5):

$$F_d = \frac{C_1 e^{-\tau s}}{TS+1} \quad (3)$$

$$F_a = C_a(v - v_m)^2 \quad (4)$$

$$F_g = M g \sin \theta \quad (5)$$

Equation (3) holds, provided F_d falls between its minimum and maximum value. The force attributed to the engine drive is modelled using a first order system with delay [8].

When a car is in motion there is a tendency of some forces acting in opposite direction of the motion which are both the F_a and F_g . The both are known as disturbance forces that tend to limit the speed of the vehicle [8]. Substituting equation (3) – (5) into equation (2) and simplifying it in term of velocity gives equation (6).

$$F_d = M \cdot \frac{dv}{dt} + C_a(v - v_m)^2 + F_g \quad (6)$$

Where $M \frac{dv}{dt}$ denotes the force of inertia. The car's actuation and propelling system employ a first order system. $F_d = \frac{C_1 e^{-\tau s}}{TS+1}$. The diagram above in Figure 2 .represent the saturation block limited to both minimum and maximum value of F_d .

Considering a minimal disturbance for the system at a set of all initial conditions equal to zero, the disturbance parameters such as wind velocity and fractional force due to the road are taken as zero as well. The model becomes a forward path with unity feedback of the response speed. If we choose the state variable as the output, v and the drive force, F_d of the system.

At initial conditions $v_m = 0$, $F_g = 0$ Equation (6) becomes:

$$\dot{V} = \frac{1}{M}(F_d - C_a v^2) \quad (7)$$

Likewise, from equation (3) Obtaining its inverse Laplace transform and making F_d the subject of the formula we get:

$$\dot{F}_d = \frac{1}{T}(C_1 u(t - T) - F_d) \quad (8)$$

The output id expressed as:

$$y = v \quad (9)$$

Hence it is require to eliminate the square term in (2) to be able to linearize the system model so as to enable easy control the system with high parameter values. In order to achieve that we need to differentiate all the state equation from left to right side of the equation with T , C_1 , M , and C_a remain constant.

We get equation (10) and (11):

$$\frac{d}{dt} \dot{V} = \frac{1}{M}(\delta F_d - 2C_a v \delta v) \quad (10)$$



$$\frac{d}{dt} \dot{F}_d = \frac{1}{T} C_1 \delta u(t - T) F_d - \frac{1}{T} \delta F_d \quad (11)$$

And the output becomes:

$$y = \delta v \quad (12)$$

Equation (10), and (11) are in time domain we need to obtain it equivalent Laplace form to be able to find the system transfer function, both δv and δF_d are in discrete form.

Laplace equivalent of equation (10) gives:

$$S \delta V(s) = \frac{\delta F_d}{M} - \frac{2C_{av} \delta V(s)}{M} \quad (13)$$

$$\left(S + \frac{2C_{av}}{M} \right) \delta V(s) = \frac{\delta F_d(s)}{M} \quad (14)$$

The Laplace transform of equation (11), we have:

$$S \delta F_d(s) = \frac{1}{T} C_1 e^{-\tau s} \delta U(s) - \frac{1}{T} \delta F_d(s) \quad (15)$$

$$\left(S + \frac{1}{T} \right) \delta F_d(s) = \frac{1}{T} C_1 e^{-\tau s} \delta U(s) \quad (16)$$

$$\delta F_d(s) = \frac{C_1 e^{-\tau s} \delta U(s)}{T \left(s + \frac{1}{T} \right)} \quad (17)$$

Substituting equation (17) into equation (14) we obtained:

$$\frac{\delta V(s)}{\delta U(s)} = \frac{C_1 e^{-\tau s}}{MT \left(s + \frac{2C_{av}}{M} \right) \left(s + \frac{1}{T} \right)} \quad (18)$$

Using the power series approximation, $e^{-\tau s}$ can be approximated as:

$$e^{-\tau s} \approx \frac{1}{1 + \tau s} = \frac{1}{\tau \left(s + \frac{1}{\tau} \right)} = \frac{\frac{1}{\tau}}{\left(s + \frac{1}{\tau} \right)} \quad (19)$$

Hence, substituting the value of $e^{-\tau}$ from (19) into (18) we get:

$$G_p(s) = \frac{\delta V(s)}{\delta U(s)} = \frac{C_1}{MT \tau \left(s + \frac{2C_{av}}{M} \right) \left(s + \frac{1}{T} \right) \left(s + \frac{1}{\tau} \right)} \quad (20)$$

Equation (18) can be represented as the bellow:

$$\frac{\Delta V(s)}{\Delta U(s)} = \frac{a e^{-\tau s}}{(s+b)(s+d)(s+d)} \quad (21)$$

$$\text{Where } a = \frac{e^{-\tau s}}{MT}, \quad b = \frac{2C_{av}}{M} \text{ and } d = \frac{1}{T}$$

TABLE 1: PARAMETERS OF THE DESIGN [8]

Parameter	Description	Value
C_1	Gain factor	5.34
M	Mass of the passengers and the car	2500Kg
τ	Time delay	0.2s
T	Time constant	1s
G	Acceleration due to gravity	9.8 m/s ²
v	Velocity of the car	20 Km/hour
C_a	Aerodynamic drag coefficient	1.23 N/(m/s ²)
$F_{d,min}$	Minimum engine drive force	4000N
$F_{d,max}$	Maximum engine drive force	4000N

Third order system been consider in this paper is a third order system, substituting the values in (21).

$$G_p(s) = \frac{1}{(s+0.019680)(s+1)(s+5)} \quad (22)$$

3. CONTROLLER DESIGN

A. PID CONTROLLER

In the paper both the Controller parameters of PID controller and the internal model controller is use to enhance the performance of the cruise control. We employ the use Ziegler-Nichols method for designing the PID controller.

The Objective is to be able to choose the appropriate values for K_p , K_i , K_d using the following procedures. [12]

- I. Start by setting K_p to a very small value, where $K_i = K_d = 0$.
- II. Increase K_p Until neural stability is achieved.
- III. Record the ultimate gain $K_u = K_p$ (at neural stability) and record critical period of oscillation T_u in seconds

IV. Look up $K_p T_i$ and T_d .

The Equation for the PID controller using Ziegler-Nichols is given as:

$$U(t) = K_p(e(t) + \frac{1}{T_i} \int_0^t e(t) d\tau + T_d \frac{de(t)}{dt}) \quad (21)$$

$$U(t) = K_p e(t) + K_p \frac{1}{T_i} \int_0^t e(t) d\tau + K_p T_d \frac{de(t)}{dt} \quad (22)$$

Where $K_i = \frac{K_p}{T_i}$, $K_p = K_i T_d$

B. IMC CONTROLLER

Internal model controllers use a model of the system being controlled to generate control signals that are sent to the system. Using the mathematical model obtained above for the cruise system and its environment to generate control for the vehicle [2], [4], [7]. Figure 3 depicts the physical layout of a feedback control system using an IMC controller. Where $G_{imc}(s)$ represents the IMC controller, $G_p(s)$ is the system model, $G_m(s)$ the process model utilized in the controller design.

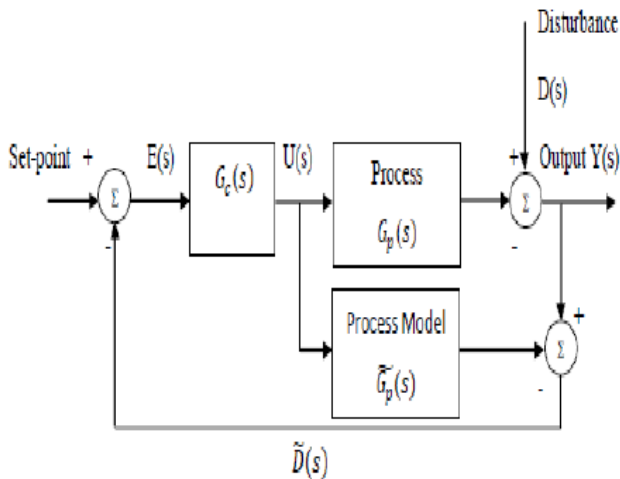

Figure 3. Layout of Feedback control System Using IMC Controller

Using the IMC controller, based on the controller $G_{imc}(s)$ and simplifying the model process $G_m(s)$ gives invertible and non-invertible part:

$$G_m(s) = G_m^+(s) * G_m^-(s) \quad (23)$$

To avoid high instability of the system the only the inverted part is taking into consideration, thereby eliminating the non-invertible part of the controller. The controller then is equal the inverse of the invertible part as:

$$G_c(s) = [G_m^-(s)]^{-1} \quad (24)$$

Adding a filter $G_f(s)$ that is as well tunable to enable the system to be stable at all time we get:

$$G_m(s) = G_c(s) * G_f(s) \quad (25)$$

$$\text{Where } G_f(s) = \frac{1}{[\lambda_f + 1]^n} \quad (26)$$

The filter parameter λ_f can selected as double the output the output response of the open loop response of $G_p(s)$ [13].

The IMC controller becomes:

$$G_{imc}(s) = \frac{(s + 0.19680)(s+1)(s+5)}{2s+1} \quad (27)$$

Table 2. PID controller based on optimized parameter [10]

Parameters	IMC- PID	
Controller Gain K_C	$\frac{2\zeta\tau}{K_p\lambda}$	$K_C = 3.33$
Integral Time T_i	$2\zeta\tau$	$T_i = 0.08$
Derivative Time T_d	$\frac{\tau}{2\zeta}$	$T_d = 0.5$

The values of the integral time $T_i = 0.08$ and the constant $K_C = 3.33$ are substituted into the rules.

Consequently, the system's IMC-PI is provided by

$$G_{PID}(s) = \frac{K_C}{T_i^2 s^2 + 2\zeta T_i s + 1} \frac{2}{0.00624s^2 + 0.032s + 1} \quad (28)$$



Table 3. Summary of Tuning Parameter

Parameters	$G_{PID} - ZN$	$G_{PID} - IMC$
Controller Gain K_C	$K_C = 12$	$K_C = 3.33$
Integral Time T_i	$T_i = 1.607$	$T_i = 0.08$
Derivative Time T_d	$T_d = 0.5$	$T_d = 0.5$

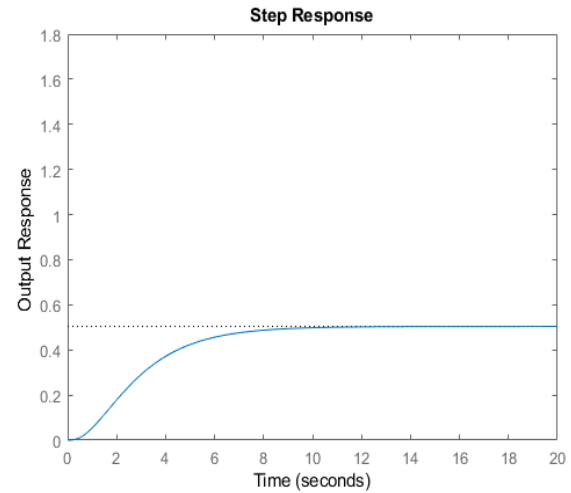

Figure 4. Open loop System Response

4. RESULTS AND DISCUSSION

The design of the controller was achieved using MATLAB-SIMULINK software version 2021. The model of the cruise control was modelled using the Simulink tools and it was depicted in the figures bellow. Based on Ziegler-Nichols Method of designing the PID controller for the system, the ultimate gain $K_u = 20$ is obtained from Routh Hurwitz stability criterion or from the simulation when the system response is neutrally stable (oscillation occur), show in Figure 5 and the period gain $T_u = 3.14secs$. From the look up table to determine the appropriate value for the PID parameters which are $K_p = 12$, $K_i = 7.6433$, $K_d = 4.7100$. The PID Parameters gives a reasonable system response as shown in figure. 6. Using the IMC controller with the filter an inverter added to the system transfer function gives equation (28) and the system transient response is shown in figure 7.

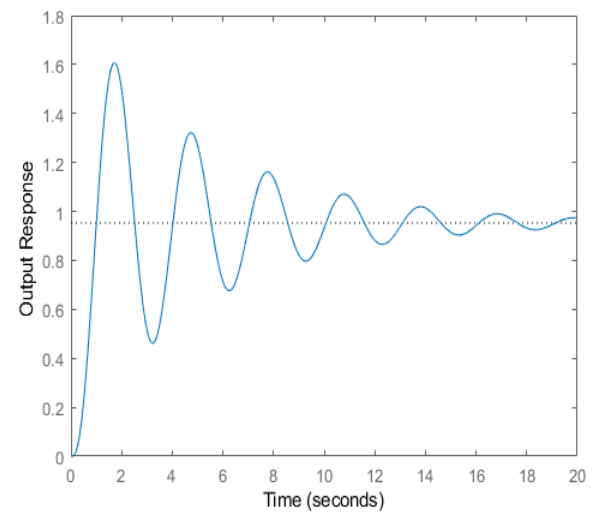

Figure. 5 Output Response of the System at Neural Stability

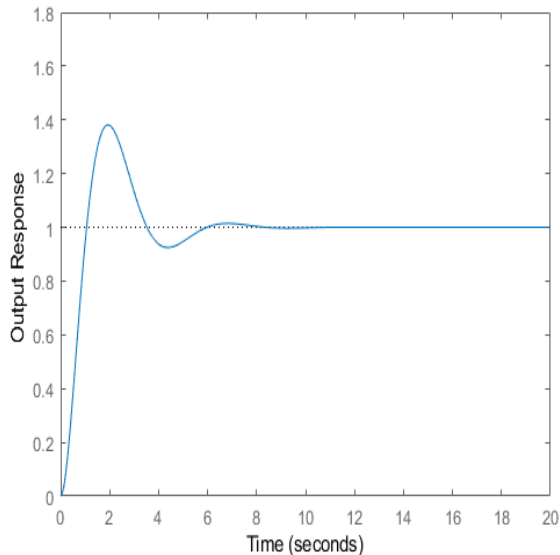

Figure 6. Output response to Ziegler-Nichols Method PID Controller

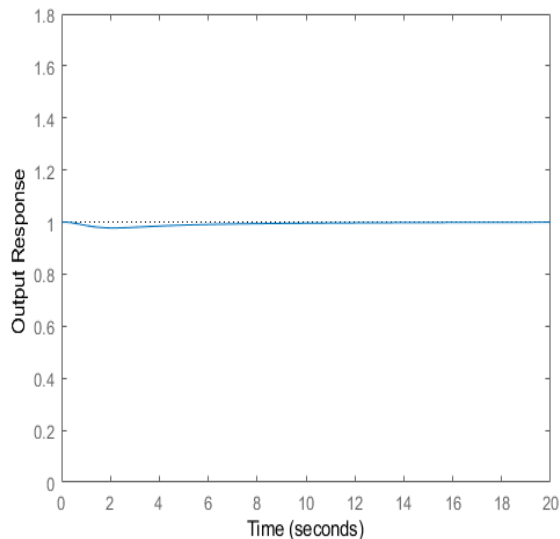

Figure. 7 Output response of IMC PID Controller

From the above diagrams it is observed that IMC-PID has a lower rise time compared to the Ziegler-Nichols PID response, and also the Ziegler-Nichols has an overshoot of about 38.1% while the IMC-PID has no overshoot, in that

case the IMC-PID has significantly improved the system compared to the Ziegler-Nichols method.

Table 4. Characteristic Performance of System and Controllers

Transient Response	System Open Loop Response	Ziegler-Nichols PID Response	IMC-PID controller Response
Rise Time (sec) T_r	4.93	0.73	0.17
Settling Time (sec) T_s	8.92	5.54	22
Overshoot %	0	38.1	0
Steady state error e_{ss}	0.504	0,985	0.821

5. CONCLUSION

In this work, a cruise system's model was determined by the mathematical modeling of the system. Using the Ziegler-Nichols Method, an appropriate PID controller was also designed for the cruise system, and an IMC controller was also created. The design of a suitable PID controller for the cruise control system was also carried out using Ziegler-Nichols Method and the IMC controller was also developed. The performance of each controller was compared based on the system transient response and steady state error. The IMC controller has significantly improved in tuning the cruise system for modern cars to set a constant speed when traveling on a highway, as seen in Table 4 in which all the responses from both the Ziegler-Nichols PID controller and IMC controller are summarized.

REFERENCE

- [1] A. R. Abdulnabi, "PID Controller Design for Cruise Control System using Particle Swarm Optimization," Iraqi Journal for computers and Informatics, vol. 43, no 2. 2017



4th International Engineering Conference (IEC 2022)
Federal University of Technology, Minna, Nigeria



- [2] D. Kim, S. Moon, J. Park, H. J. Kim, and K. Yi, "Design of an Adaptive Cruise Control / Collision Avoidance with lane change support for vehicle autonomous driving," in 2009 ICCAS-SICE, 2009, pp. 2938–2943
- [3] F. Diba, A. Arora, E. Esmailzadeh, "Optimized robust cruise control system for an electric vehicle," *Systems Science & Control Engineering: An Open Access Journal*, 2014, vol 2, no 1, pp 175-182
- [4] F. T. Abiodun, B. S. Habeeb, O. O Mikail, N. Abdul Wahab, "Control of a Two Layered Coupled Tank: Application of IMC, IMC-PI and Pole-Placement PI Controllers," *International Journal of Multidisciplinary Sciences and Engineering*, 2013, vol 4, no 11, pp
- [5] D. E. Rivera, M. Morari, and S. Skogestad, "Internal model control: PID controller design," *Industrial & engineering chemistry process design and development*, vol. 25, pp. 2522-2535, 1986.
- [6] K. J. Astrom and T. Hagglund, "PID Controllers: Theory, Design and Tuning," second ed: Instrument society of America, 1995.
- [7] S. Bdran, M. Shuyuan, S. Saifullah, and H. Jie, "Comparison of PID, Pole Placement and LQR Controllers for speed ration control of continuously Variable Transmission (CVT)," in ICAMECE 2013, pp. 149-154.
- [8] M. M. Gulzar, B. Sharif, D. Sibtain, L. Akbar, A. Akhtar "Modelling and Controller Design of Automotive Cruise Control System using Hybrid Model Predictive Controller." IEEE International Conference on Emerging Technologies (ICET), 2019
- [9] A. Arora, Y. Lu, F. Diba, & E. Esmailzadeh, "Robust cruise control system for electric vehicle". International conference on mechanical Engineering and Mechatronics, Toronto, Ontario, Canada, 2018
- [10] K. Osman, M. F. Rahmat, & M. A. Ahmad. ".Modelling and controller design for a cruise control system." 5th International Colloquium on Signal Processing and its applications ,CSPA2009, Kuala Lumpur, Malaysia, pp. 254– 258.
- [11] D. E. Rivera, "Internal Model Control, A Comprehensive View," Arizona State University, Tempe, Arizona 85287-6006, October 27, 1999.
- [12] N Adhikari, M Choubey and R Singh, "DC motor control using Ziegler–Nichols and genetic algorithm technique" International Journal of Electrical, Electronics and Computer Engineering, April 2012
- [13] F. T. Abiodun, J. A. Bala, A. P. Adedigba "Genetic Algorithm Tuned IMC-PI Controller for Coupled Tank Based Systems." ICECO 2021"