

TOWARDS A HYBRID STATISTICAL FEATURE EXTRACTION AND HIERARCHICAL CLASSIFICATION MODEL FOR DIABETIC RETINOPATHY DIAGNOSIS

¹Abdullahi I. M, ²Arulogun O. T, ³Adeyanju I.A, ⁴Olaniyi O. M, ⁵Nuhu B. K.

^{1, 4&5}Department of Computer Engineering

Federal University of Technology Minna, Niger State, Nigeria

^{2&3}Department of Computer Science and Engineering

LadokeAkintola University of Technology, Ogbomosho, Nigeria

amibrahim@futminna.edu.ng, arulogundiran@gmail.com, jaadeyanju@lautech.edu.ng and
mikail.olaniyi@futminna.edu.ng

Abstract

Diabetic retinopathy (DR) is one of the leading causes of blindness worldwide. It is a disease that is caused by diabetes which affects the retina. Early detection of the disease can prevent blindness but it is affected by few or lack of visible symptoms in its early stage. The application of digital image processing, machine learning and pattern recognition techniques has provided fast, cost effective, accurately and automated screening of the disease using fundus images which solves the problems of manual screening. However, automated screening of diabetic retinopathy using fundus images are generally affected by poor fundus image quality and high correlation of the in-between DR grade fundus image statistical features which affects the performances of classifiers. We propose an improved hybrid statistical feature extraction approach using first order and second order gray level co-occurrence matrix (GLCM) and hierarchical classification model using artificial neural network (ANN) for diabetic retinopathy screening. The implementation success will minimize correlation effect and improve classifier performance, enable fast, effective, accurate, automated and convenient means of diagnosing diabetic retinopathy.

Key words: Diabetic Retinopathy, Artificial Neural Network, Gray level co-occurrence matrix, Fundus Images, First Order, Second Order.

1.0 Introduction

Diabetic retinopathy (DR) is a progressive, chronic and sight-threatening disease that affects the vessels of the retina. It is caused by conditions associated with diabetes mellitus like prolonged hyperglycemia and hypertension [31]. DR is the leading cause of blindness in adult worldwide estimated to about 5% of total blindness [13]. It is the leading cause of blindness in the United State, the second leading cause of blindness in Western world and the sixth leading cause of blindness in India [39].

The rapid increase of diabetics especially in low income countries, shortage of expert ophthalmologists and resources, high cost of treatment and time spent on labor-intensive screening are some of the limitations of manual DR screening. This helps in increasing the number of unscreened patients [27]. Mass-screening and regular eye examination remains the only way for early detection and treatment to prevent vision loss in large number of patients suffering from the disease which can reduce the risk by 50% [12]. Therefore, an accurate, automatic or semi-automatic, fast and cost effective technique is needed for mass screening of DR.

DR diagnosis is based on eye examination of fundus images and is essential because of its ease of use, reliability, non-invasiveness, better sensitivity and better abnormality detection [16]. However, classifiers performances are reduced by poor fundus image quality and correlation in fundus image data [10] [36].

The use of automated technique for DR screening have some advantages over the manual method of screening because it can significantly decrease the manual labor and time of diagnoses for large quantities of retinal images [27], it also present a cost effective screening that is required for preventive action to stop the progression of the disease [37].

Texture is one of the important characteristics used in identifying objects or regions of interest in an image because it contains important information about the structural arrangement of surfaces. Gray level co-occurrence matrix (GLCM) is a powerful tool proving to be useful in texture classification and various textural parameters calculated from the GLCM help to understand the details about the overall image content [11].

This paper proposed the application of statistical texture feature extraction technique and neural network to the design and development of a hybrid statistical feature extraction and hierarchical classification model for detection and classification of DR into four grades. The model is proposed for automated, efficient and early screening of DR aimed at assisting ophthalmologist in screening patients with diabetic retinopathy.

There are four stages of DR which depends on the symptoms and progression of the disease, they are: mild non-proliferative (mild NPDR), moderate non-proliferative DR (moderate NPDR), severe non-proliferative DR (Severe NPDR) and proliferative DR (PDR) as shown in Figure 1.

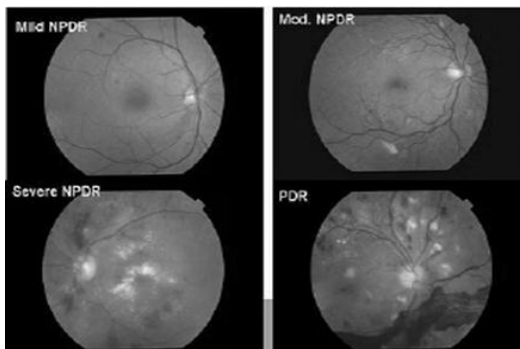

Figure1: Diabetic Retinopathy stages [22]

2.0 Related Works

There are several automated diabetic retinopathy diagnostic systems that exist in literatures, these techniques are either image processing based techniques or machine learning and pattern recognition based techniques that require the use of classifiers.

i. Image Processing Based Techniques

The image processing based techniques uses various image processing algorithms for diagnosing of diabetic retinopathy (DR). Most of the works done using image processing based techniques target detection of symptom(s) of diabetic retinopathy such as; exudates [2] [22] [21], Hemorrhage [3], crossover points and micro aneurysms [3].

[2] used a multi-space image processing technique to detect exudates, their system performance was low that is sensitivity and accuracy is 76.96% and 89.7% respectively. [22] Developed a system that classifies exudates as mild, moderate and severe based on their position from macula using texture feature extraction from GLCM. Although their system performance was high, 95% and 98% respectively for sensitivity and specificity, the over reliance on segmentation and considering exudates alone makes the system incomplete.

ii. Machine Learning and Pattern Recognition Based Techniques

Machine learning and pattern recognition based techniques requires the extraction features from the fundus input image after pre-processing and training of a classifier to detect and classify the disease [28] [29] [30] [33]. The next section discusses related feature extraction and classification techniques used for medical image diagnosis.

2.1 Feature Extraction

Feature extraction is a method of capturing visual content or information from images. It is also the computation of characteristics of digital images in terms of their numerical value, [25] [23]. The features extracted from images could be low level features like colour, shape and texture [25]

Texture is one of the important characteristics used in identifying objects or regions of interest in an image and it contains important information about the structural arrangement of surfaces [11]. The textural features based on gray-tone spatial dependencies and GLCM have a general applicability in image classification and segmentation [11].

2.1.1 First Order Feature Extraction

First order statistical features are histogram based, that is the features are extracted from the histogram of the images. The most frequently used first order features are variance (μ_2), skewness (μ_3) and kurtosis (μ_4) [1]. Skewness is the measure of the degree of histogram asymmetry around the Mean, Kurtosis is a measure of the histogram sharpness and Variance is a measure of the histogram width and the deviation of gray levels from the Mean [1].

Equations 1 – 4 show the formula for calculating mean, variance, kurtosis and skewness of an image.

$$\text{Mean: } \mu = \sum_{i=0}^{G-1} iP(i) \quad 1$$

$$\text{Variance: } \mu_2 = \sigma^2 = \sum_{i=0}^{G-1} (i - \mu)^2 P(i) \quad 2$$

$$\text{Skewness: } \mu_3 = \sigma^{-3} \sum_{i=0}^{G-1} (i - \mu)^3 P(i) \quad 3$$

$$\text{Kurtosis: } \mu_4 = \sigma^{-4} \sum_{i=0}^{G-1} (i - \mu)^4 P(i) - 3 \quad 4$$

2.1.2 Second Order Feature Extraction (GLCM Based)

Second order feature extraction is the statistical method of examining the textures of images by considering the spatial relationship of the pixels [40]. Gray Level Co-occurrence Matrix (GLCM) assesses image properties associated to Second-Order statistics. [40] shows that the number of gray level 'G' of an image is represented by the row and column of GLCM and the element used by the matrix is given as:

$$P(i, j | \Delta x, \Delta y) \text{ and } P(i, j | d, \theta) \quad 5$$

Where in the first expression of equation 5, $p(i, j)$ represent the frequency of the matrix element separated by the distance $\Delta x, \Delta y$ and the second expression represents the second order probability values for changes between gray levels i and j at a distance d and angle θ .

Most features in medical images are all functions of angle and distance and using only horizontal or diagonal offset may not be a better representation of the entire image [15]. Several features can be extracted from GLCM which are used to train classifiers whose performance depends on the extracted features. Some second order features that can be extracted from GLCM as given by [40] are;

1. Angular second moment (ASM) or Homogeneity

The ASM is known as uniformity or energy. It measures the homogeneity of an image. When pixels are very similar, the ASM value will be large. It is given as:

$$ASM = \sum_{i=0}^{G-1} \sum_{j=0}^{G-1} \{P(i, j)\}^2 \quad 6$$

2. Entropy

Entropy shows the amount of information of the image that is needed for image compression. Entropy also measures the loss of information or message in a transmitted signal or the amount of energy permanently lost

during reaction. It can also be defined as the amount of irremediable chaos or disorder. The equation is shown in equation 2.36.

$$Entropy = - \sum_{i=0}^{G-1} \sum_{j=0}^{G-1} p(i,j) * \log(p(i,j)) \quad 7$$

3. Contrast

It is a measure of intensity contrast between a pixel and its neighbor pixel over the whole image. It is zero for constant image.

$$contrast = \sum_{n=0}^{G-1} n^2 \left\{ \sum_{i=0}^{G-1} \sum_{j=0}^{G-1} P(i,j) \right\}, |i - j| \quad 8$$

4. Inverse difference moment

Inverse Difference Moment (IDM) is the local homogeneity which is high when local gray level is uniform and inverse GLCM is high.

$$IDM = \sum_{i=0}^{G-1} \sum_{j=0}^{G-1} \frac{1}{1 + (i - j)^2} \quad 9$$

Two parameters of interest while using GLCM technique is the pixel-pair distance 'd', and the gray level quantization with more gray levels would mean more accurate extracted textural information, with increased computational costs [10].

GLCM feature extraction has been applied successfully for most diagnostic systems and performs better than principal component analysis (PCA) feature extraction technique [Singh]. Extracting second order features at higher gray levels makes the performance of classification better but at higher computation time [10].

Haar wavelet based GLCM feature extraction to reduce the computational complexity of normal GLCM approach was proposed by [26], eight gray levels at distance of 1 for brain tumor classification were proposed by [40].

2.1.3 Hybrid Statistical Feature Extraction

The use of first and second order statistical texture feature extraction have been tested to perform better and faster than other feature extraction techniques such as wavelet based feature extraction methods because far less number of distinguishable features is produced [1]. More than one feature extraction techniques have been successfully applied for many automated medical diagnostic system. [32] Used first and second order feature extraction for glaucoma classification at six different quantization levels and four orientations, while brain tumor was diagnosed using first and second order in [1]. A hybrid technique for automatic classification of MRI images as well as natural images was proposed by [34].

Table 1: Summary of Some Feature Extraction Techniques and their Disadvantages.

Author	Research methodology	Disadvantage
[1]	First and second order statistical (FSS) feature extraction for MRI classification in comparison to wavelet based feature extraction technique.	Wavelet based feature extraction technique performs poorly
[6]	Colour GLCM feature extraction technique in comparison to Gabor filter (GF) technique.	Computationally expensive to process colour images than gray level images.

[25]	Image resolution effect on GLCM based feature extraction.	Angle of image objects is not considered
[22]	Statistical and shape based feature extraction to detect exudates	Relies heavily on segmentation.
[30]	Classification of fundus image into three grades using six structural (circular) based features.	Required accurate segmentation which is computationally expensive
[34]	Classification of tumor in brain MRI images using GLCM, PCA and SVM.	PCA feature extraction technique performance is low.

2.2 DR Classification Techniques

Classification in pattern recognition is a procedure for sorting pixels and assigning them to specific group or categories using classifiers. The pixels are characterized by features such as texture, gray value, colour and so on [9]. Classification can be supervised or un-supervised, in supervised classification, training data whose labels are known. Examples are Minimum distance classifier, Maximum likelihood classifier, neural network classifier, support vector machine classifier and so on, while in Un-supervised classification, no training data is required. Examples are K-means clustering, Fuzzy C-means, ISODATA, etc., [9]. The most popular classifiers used for classification of diabetic retinopathy are the artificial neural network classifiers and support vector machine classifiers.

2.2.1 Artificial Neural Network

Artificial neural networks (ANN) are networks constituted by highly interconnection of artificial

neurons that mimic the behavior of the brain in a simplified computational form [5]. A neuron is the fundamental information-processing unit of a ANN that consists of a set of synaptic links, an adder and an activation function that receives information, process it mathematically and pass it to other neurons [35]. They are used to perform computations like pattern recognition, pattern matching, classification and forecasting. Mathematically, the function of k^{th} neuron in a neural network is given by [35] as:

$$U_k = \sum_{j=0}^m W_{kj} X_j$$

with $X_0 = 1, b_k = W_{k0}$ and $y_k = f(b_k)$ 10

ANN learns by the progressive change in its synaptic weight [8], Figure 2 and 3 show the artificial neurones structure and interconnection of neurons respectively.

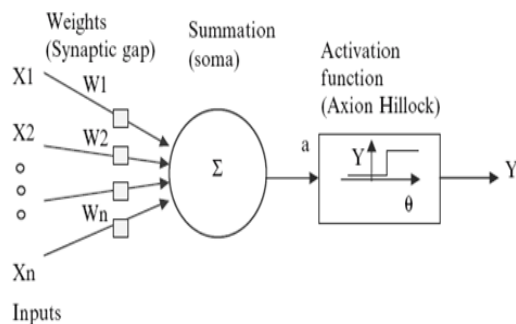

Figure 2: Artificial neurone structure (perceptron model) [8]

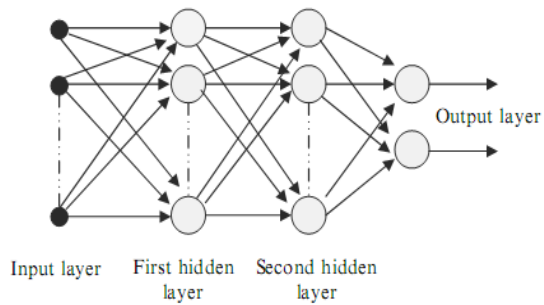

Figure 3: A simple 3-layer ANN [8]

The hidden layer neurons are important in training of multi-layer perceptron neural network (networks with hidden layers) with back-propagation learning in which they act as feature detectors [35]. Back propagation learning with gradient descent training algorithm is usually slow in learning with 72 hours recorded for the system proposed by [14], and one hour training time with multi-layer neural network architecture with 10 input feature vectors was recorded by [28]. 18 input was used by [29] to train a three layer perceptron network which performs better than K-nearest neighbor classifier.

[30] applied probabilistic neural network (PNN) to classify a fundus image as normal, PDR or NPDR. [19] developed an unsupervised neural network, learning vector quantization (LVQ) NN or self-organizing map (SOM) to detect the candidate micro-aneurysms in retinal angiogram, [14] applied artificial neural network with back-propagation as the learning mechanism to classify the retinal image data into (normal, vessel, exudates, and hemorrhages) already labeled manually using delta learning rule with 80 to 300 hidden units.

An automated system for early diagnosis of diabetic retinopathy using segmentation, GLCM feature extraction and support vector machine (SVM) was developed by [33] shown in Figure 4. The Performance is 93% and the limitation of this system is the reliance on segmentation which is very tasking and prone to errors. The sensitivity of the classifier is 90% and specificity is 88%.

2.2.2 Support Vector Machines (SVM)

SVM is a supervised classifier like ANN, it learns statistically based on structural minimization of input vector and mapping it into a high dimensional feature space using a non-linear mapping kernel [20].

[30] Evaluates the performance of two models, probabilistic neural network (PNN) and support vector machine (SVM) to classify a fundus image as

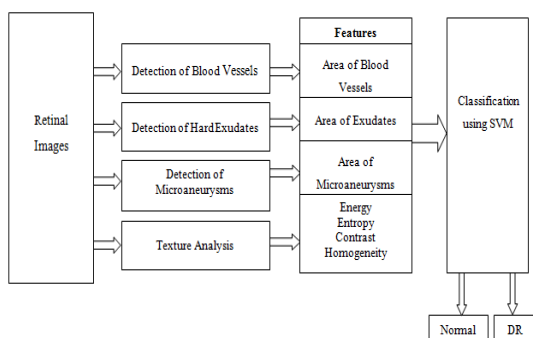

Figure 4: Automated diabetic retinopathy system [33]

Normal, non-proliferative DR, and proliferative DR. Six structural features were extracted from 250 samples, and result shows that SVM classifier performs better than PNN for 255*6 input feature vectors. The accuracy of SVM and PNN are 97.6% and 89.6% respectively. Classification of DR using SVM into normal, NPDR and PDR was proposed by [7] using both structural and texture features as shown in Figure 5.

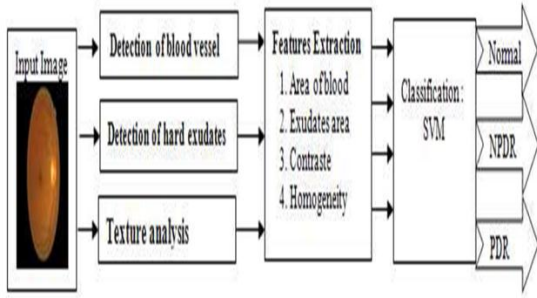

Figure 5: Diabetic retinopathy classification system [7]

A hybrid feature extraction technique for classification of magnetic resonance images (MRI) and natural images using principal component analysis (PCA) and SVM was proposed by [34]. For brain images, features extracted with GLCM gives 100% and natural images gives 91.6% accuracy using SVM-RBF kernel function.

Automatic detection of red lesions in ocular fundus image using pixel based classification and mathematical morphology was proposed by [20]. The red lesions candidate was classified using some features calculated from co-occurrence matrix and linear kernel SVM classifier was used for the classification. Their result after testing on 89 images from different databases and found to have 91% specificity and 100% sensitivity.

2.3 Principal Component Analysis

Real world data samples especially medical image data used to train artificial neural networks (ANNs) and other classifiers consist of correlated information caused by overlapping input instances. Confusion is normally created by correlation for classifiers during the learning process and thus, degrades their generalization capability [18].

Principal component analysis is one statistical tool used to reduce this correlation in input data for enhancing the performance of the classification by using a lower number of principal components instead of the high-dimensional original data and this done by taking linear combinations of the original variables of the form:

$$H_1 = b'_1 k = b_{11}K_1 + b_{12}K_2 + \dots + b_{1m}K_m \quad 11$$

$$H_2 = b'_2 k = b_{21}K_1 + b_{22}K_2 + \dots + b_{2m}K_m \quad 12$$

...

$$H_p = b'_p k = b_{p1}K_1 + b_{p2}K_2 + \dots + b_{pm}K_m \quad 13$$

Where $b_{11}, b_{12} \dots b_{pm}$ are known as the loading parameters and K_1 is the first principal component with maximum variance.

3.0 Research Direction

Our aim in this research is to develop an efficient and automated multi-class diabetic retinopathy (DR) diagnostic system with a hybrid feature extraction and hierarchical classification model that will detect and classify DR into four grades (normal, mild, moderate and severe). The architecture of the proposed system is shown in figure 6.

The proposed method is expected to solve problems related to manual DR diagnosis, reduce the effect of low fundus image quality and high correlation in fundus image data in automated detection techniques.

To achieve this, we proposed the use of a hybrid statistical first order and gray level co-occurrence matrix feature extraction with feed-forward back propagation artificial neural network classifier arranged in hierarchy.

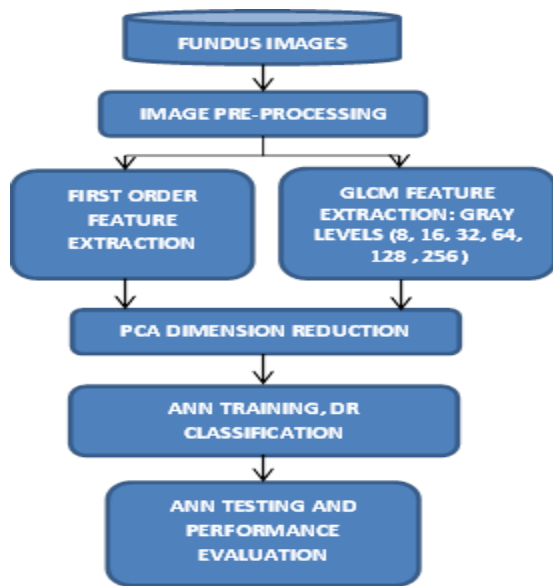

Figure 6: The proposed system architecture.

The database that will be used for training and testing of the system will be from MESSIDOR database: a publicly available database that contains fundus images whose DR grades have been classified by expert ophthalmologist.

After preprocessing the images, texture features will be extracted, principal component analysis (PCA) will be used to reduce the dimension of the extracted features which will then be used as input to the classifier for training and testing. The system will be simulated using Matlab 2012a and its performance will be evaluated by calculating its sensitivity, specificity and accuracy.

4.0 Conclusion

Diabetic retinopathy is a preventable disease that affects the retina and one of the leading causes of blindness in the world. Early detection of the disease reduces the risk of going blind, but shortage of expert ophthalmologist makes the current screening procedures very expensive and time consuming. The hybrid feature extraction and hierarchical classification model proposed in this paper will be evaluated based on sensitivity, specificity and accuracy. It is expected not only to provide faster, accurate and convenience means of screening the disease but also, reduce the effect of poor fundus image quality and correlation in fundus image data which affects classifier performance of most diabetic retinopathy diagnostic systems.

5.0 References

- [1] Aggarwal, N., & Agrawal, R., (2012), "First and Second Order Statistics Features for Classification of Magnetic Resonance Brain Images", *Journal of Signal and Information Processing*, Vol. 3, Issue 2, pp. 146-153.
- [2] Ahmed, M. M., Basu, S., & Kumaravel, A., (2013), "Clustering Technique for Segmentation of Exudates in Fundus Image", *International Journal of Engineering Sciences & Research, Technology*, Vol. 2, Issue 6, pp. 1586-1590.
- [3] Aibinu, A. M., Iqbal, M. I., Nilsson, M., & Salami, M. J. E., (2007), "Automatic Diagnosis of Diabetic Retinopathy from Fundus Images Using Digital Signal And Image Processing Techniques", Submitted to International Conf. on Robotics, Vision, Information, and Signal Processing, Malaysia, pp. 510-515.

- [4] Akara Sopharak, Bunyarit Uyyanonvara, Sarah Barmanb, & Thomas H. Williamson, (2008), "Automatic detection of diabetic retinopathy exudates from non-dilated retinal images using mathematical morphology methods", *Computerized Medical Imaging and Graphics Vol.32*, pp. 720–72.
- [5] Alvisi S. Mascellani. G., Franchini. M. & B'ardossy. A., (2006), "Water Level Forecasting Through Fuzzy Logic and Artificial /Neural Network Approaches", *Hydrology and Health System Science, Vol. 10*, pp. 1-17.
- [6] BENČO, M., & Hudec, R. (2007). Novel method for colour textures features extraction based on GLCM. *Radioengineering, Vol. 4, Issue 16*, pp.64-67.
- [7] Berrichi Fatima & Zohra, Benyettou Mohamed (2009), "Automated Diagnosis of Retinal Images Using the Support Vector Machine (SVM)", *Faculte des Science, Department of Informatique, USTO, Algeria*.
- [8] Chaturvedi D. K., (2008), "Soft Computing Techniques and its Applications in Electrical Engineering", *Studies in Computational Intelligence (SCI) Vol. 103*, pp. 23–50.
- [9] Chijindu, V. C., Inyama, H. C., & Uzedhe, G., (2012), "Medical Image Segmentation Methodologies - A Classified Overview. *African Journal of Computing and ICT, Vol. 5, Issue 5*, pp. 100-108.
- [10] Clausi, D. A., (2002), "An Analysis of Co-Occurrence Texture Statistics as a Fuction of Grey-level Quantization", *can.j. Remote sensing, Vol. 28, No. 1*, pp. 45-62.
- [11] Dhanashree Gadkari (2004), "Image Quality Analysis Using GLCM", A thesis submitted in partial fulfillment of the requirements for the degree of Master of Science in Modeling and Simulation in the College of Arts and Sciences at the University of Central Florida Orlando, Florida. Retrieved Feb. 2014.
- [12] Fong. D. S. , L. Aiello, T. W. Gardner, G. L. King, G. Blankenship, J. D. Cavallerano, F. L. Ferris & R. Klein, (2003), "Diabetic Retinopathy", *Diabetes Care, Vol. 26*, pp. 226–229.
- [13] Foster, A., & Resnikoff, S. (2005), "The impact of Vision 2020 on Global Blindness", *Cambridge Ophthalmological Symposium: Eye, Vol. 19, Issue 10*, pp. 1133-1135.
- [14] Gardner, G., Keating, D., Williamson, T., & Elliott, A. (1996). "Automatic Detection of Diabetic Retinopathy uUing an Artificial Neural Network: A Screening Tool, *British journal of Ophthalmology, Vol. 80, Issue 11*, pp. 940-944.
- [15] Haralick, R. M., Shanmugam, K., & Dinstein, I. H. (1973), "Textural Features for Image Classification", *Systems, Man and Cybernetics, IEEE Transactions, Vol. 6*, pp. 610-621.
- [16] Hutchinson, A., McIntosh, A., Peters, J., O'Keeffe, C., Khunti, K., Baker, R., and Booth, A. Effectiveness of screening and monitoring tests for diabetic retinopathy – a systematic review. *Diabetic medicine 17, 7* (July 2000), 495–506.
- [17] Jilani, T. A., Yasin, H., & Mohammad Yasin, M. (2011), "PCA-ANN for Classification of Hepatitis-C Patients", *International Journal of Computer Applications, Vol. 14, Issue 7*, pp. 1-6.
- [19] Kamel, M., Belkassim, S., Mendonca, A. M., & Campilho, A. (2001), "A neural network approach for the automatic detection of microaneurysms in retinal angiograms", Paper presented at the Neural Networks, Proceedings, IJCNN'01, International Joint Conference.
- [20] Kande, G. B., Savithri, T. S., & Subbaiah, P. V. (2010). Automatic Detection of Microaneurysms and Hemorrhages in Digital Fundus Images. *Journal of digital imaging, 23(4)*, pp. 430-437.
- [21] Kittipol Wisaeng, Nualsawat Hiransakolwong & Ekkarat Pothiruk (2012), "Automatic Detection of Exudates in Diabetic Retinopathy Images", *Journal of Computer Science Vol. 8, Issue 8*: pp. 1304-1313.
- [22] Kumar Prassana. S. C., & Deepashree Devaraj (2013). Automatic exudate detection for the diagnosis of DR. *International Journal of Innovative Research and Studies*, pp. 658-669.

- [23] Materka, A., and Strzelecki, M. (1998), "Texture analysis methods-a review", Technical University of Lodz, Institute of Electronics, *COST B11 Report, Brussels*, pp. 9-11.
- [24] Messidor (2013), "Methods to evaluate segmentation and indexing techniques in the field of retinal ophthalmology", Retrieved at <http://messidor.crihan.fr>, Accessed Oct, 2013.
- [25] Mohanaiah, P., Sathyanarayana, P., & GuruKumar, L. (2013), "Image Texture Feature Extraction Using GLCM Approach", *International Journal of Scientific and Research Publications*, Vol. 3, Issue 5.
- [26] Mokji. M. M., & Abu bakar. S. A. R., (2007), "Gray Level Co-Occurrence Matrix Computation Based on Haar Wavelet", *Computer Graphics, Imaging and Visualization*, Vol. 3, Issue 7, 0-7695-2928.
- [27] Nathan Silberman, Kristy Ahlrich, Rob Fergus & Lakshminarayanan Subramanian (2010), "Association for the Advancement of Artificial Intelligence", retrieved from (www.aaai.org).october, 2013.
- [28] Osareh, A., Mirmehdi, M., Thomas, B., & Markham, R. (2001), "Automatic Recognition of Exudative Maculopathy Using Fuzzy C-Means Clustering and Neural Networks", Paper presented at the Medical image understanding and analysisin, *Proc. Medical Image Understanding Analysis Conf.*, pp. 49–52.
- [29] Osareh, A., Mirmehdi, M., Thomas, B., & Markham, R. (2003), "Automated identification of diabetic retinal exudates in digital colour images", *British Journal of Ophthalmology*, Vol. 87, Issue10, pp. 1220-1223.
- [30] Priya, R., & Aruna, P. (2012), "SVM and Neural Network based Diagnosis of Diabetic Retinopathy", *International Journal of Computer Applications*, Vol. 41, Issue 1, pp. 6-12.
- [31] Royal College of Ophthalmologists, (2012), "Diabetic Retinopathy Guidelines, Scientific department", The Royal College of Ophthalmologists, retrieved from www.rcophth.ac.uk, on 15/10/2013.
- [32] SakthivelKarthikeyan& N. Rengarajan, (2014), "Performance Analysis of Gray Level Co-Occurrence Matrix Texture Features for Glaucoma Diagnosis", *American Journal of Applied Sciences*, Vol. 11, Issue 2: pp. 248-257.
- [33] Selvathi D, N.B.Prakash, NeethiBalagopal, (2012), "Automated Detection of Diabetic Retinopathy for Early Diagnosis Using Feature Extraction and Support Vector Machine", *International Journal of Emerging Technology and Advance Engineering*, Vol. 2, Issue 11, pp. 103-108.
- [34] Singh, D., & Kaur, K. (2012), "Classification of Abnormalities in Brain MRI Images Using GLCM, PCA and SVM", *International Journal of Engineering*, Vol. 1, pp. 2249-8958.
- [35] Tahseen A. Jilani, Huda Yasin, &Madiha Mohammad Yasin, (2011), "PCA-ANN for Classification of Hepatitis-C patients". *International Journal of Computer Applications*, Vol. 14, Issue 7, pp. 0975-8887.
- [36] Teng, T., M. Lefley, & D. Claremont (2002), "Progress Towards automated Diabetic Ocular Screening: a Review of Image Analysis and Intelligent Systems for Diabetic Retinopathy", *Med. & Biological Engineering & Computing*, Vol. 40, pp. 2-13.
- [37] Tomi Kauppi (2010), "Eye Fundus Image Analysis For Automatic Detection of Diabetic Retinopathy", Doctoral Dissertation presented at Lappeenranta University of Technology Acta Universitatis Lappeenrantaensis, Vol. 444, pp. 150.
- [38] Whiting D. R., Guariguata, L. W, & Shaw, J. (2011), "IDF diabetes atlas: global estimates of the prevalence of diabetes for 2011and 2030", *Diabetes research and clinical practice*, Vol. 94, Issue 3, pp. 311-321.
- [39] Zhang H., Jason E. F., & Sally A. G (2008), "Image segmentation evaluation: A survey of unsupervised methods", *Computer Vision and Image Understanding*, 110, 60–280.
- [40] Zulpe, N., & Pawar, V. (2012), "GLCM Textural Features for Brain Tumor Classification", *IICSI International Journal of Computer Science issues*, Vol. 9, Issue 3, pp. 354-359