

**Volume 15, Issue 2/2015**

**PRINT ISSN 2284-7995**

**E-ISSN 2285-3952**



# **SCIENTIFIC PAPERS**

**SERIES “MANAGEMENT, ECONOMIC  
ENGINEERING IN AGRICULTURE AND RURAL  
DEVELOPMENT”**

**Volume 15, Issue 2/2015**

**PRINT ISSN 2284-7995**

**E-ISSN 2285-3952**



# **SCIENTIFIC PAPERS**

**SERIES “MANAGEMENT, ECONOMIC  
ENGINEERING IN AGRICULTURE AND RURAL  
DEVELOPMENT”**

To be cited: Scientific Papers Series “Management, Economic Engineering in Agriculture and Rural Development”, Volume 15, Issue 2/2015

**Publishers:**

**University of Agricultural Sciences and Veterinary Medicine of Bucharest, Romania.** Address: 59 Marasti, District 1, 011464 Bucharest, Romania, Phone: + 40213182564, Fax: +40213182888, www.managusamv.ro  
**S.C. Editura Ceres S.A.,** Address: 1 Piata Presei Libere, District 1, Bucharest, 013701, Phone/Fax: +40213179023, Email: edituraceres@yahoo.com  
All rights reserved

**The publishers are not responsible for the content of the scientific papers and opinions published in the Volume. They represent the authors' point of view.**

**EDITORIAL BOARD**

**Editor in Chief: Prof. Ph.D. Toma Adrian DINU**

**Executive Editor: Prof. Ph.D. Agatha POPESCU**

**Members:**

**Prof. Ph.D. Ioan Nicolae ALECU,** University of Agricultural Sciences and Veterinary Medicine, Bucharest, Romania  
**Prof. Ph.D. Manea DRĂGHICI,** University of Agricultural Sciences and Veterinary Medicine, Bucharest, Romania  
**Prof. Ph.D. Mihai BERCA,** University of Agricultural Sciences and Veterinary Medicine, Bucharest, Romania  
**Prof. Ph.D. H.C. Miguel Moreno MILLAN,** University of Cordoba, Spain  
**Prof. Ph.D. Doc. Svend RASMUSSEN,** University of Copenhagen, Denmark  
**Prof. Ph.D. Mogens LUND,** Institute of Food and Resource Economics, Copenhagen, Denmark  
**Prof. Ph.D. Pascal Anton OLTENACU,** Oklahoma State University, United States of America  
**Prof. Ph.D. Rangesan NARAYANAN,** University of Nevada, United States of America  
**Senior Lecturer Ph.D. Ove MADSEN,** Grinsted Agricultural Academy, Denmark  
**Ph.D. Patrick ANGEL,** US Department of the Interior, Office of Surface Mining Appalachian Regional Office, U.S.A.  
**Prof. Ph.D. Gerhard MOITZI,** University of Natural Resources and Applied Life Sciences, Vienna, Austria  
**Prof. Ph.D. Paolo GAJO,** University of Florence, Italy  
**Prof. Ph.D. Diego BEGALLI,** University of Verona, Italy  
**Prof. Ph.D. Mamdouh Abbas HELMY,** Modern University for Technology and Information, Cairo, Egypt  
**Ph.D. Alistair Mc CRACKEN,** Agri-Food and Biosciences Institute, Belfast, United Kingdom  
**Prof. Ph.D. Drago CVLJANOVIC,** Institute of Agricultural Economics, Serbia  
**Prof. Ph.D. Nebojsa RALEVIC,** University of Belgrade, Serbia  
**Dr. Hab. Stefan MANN,** Research Station Agroscope, Federal Office for Economics, Tanikon, Switzerland  
**Ph.D. Jonel SUBIC,** Institute of Agricultural Economics, Serbia  
**Associate Professor Ph.D. Zuzana PALKOVA,** Slovak University of Agriculture, Nitra, Slovakia  
**Acad. Prof. Ph.D. Hab. Pavel MOVILEANU,** The Agricultural State University of Moldova, Republic of Moldova  
**Senior Lecturer Ph.D. Veronica PRISĂCARU,** The Agricultural State University of Moldova, Republic of Moldova  
**Senior Lecturer Ph.D. Veronica MOVILEANU,** The Agricultural State University of Moldova, Republic of Moldova  
**Senior Lecturer Ph.D. Mariana DOGA-MIRZAC,** Moldova State University, Republic of Moldova  
**Associate Prof. Ph.D. Rashid SAEED,** International Islamic University, Pakistan  
**Senior Lecturer Ph.D. Adrian TUREK-RAHOVEANU,** University of Agricultural Sciences and Veterinary Medicine, Bucharest, Romania  
**Prof. Ph.D. Emilian MERCE,** University of Agricultural Sciences and Veterinary Medicine, Cluj-Napoca, Romania  
**Prof. Ph.D. Gheorghe MUREȘAN,** University of Agricultural Sciences and Veterinary Medicine, Cluj-Napoca, Romania  
**Prof. Ph.D. Nicoleta MATEOC-SÎRB,** University of Agricultural Sciences and Veterinary Medicine of Banat, Romania  
**Prof. Ph.D. Ion DONA,** University of Agricultural Sciences and Veterinary Medicine, Bucharest, Romania  
**Prof. Ph.D. Elena STOIAN,** University of Agricultural Sciences and Veterinary Medicine, Bucharest, Romania  
**Senior Lecturer Ph.D. Silviu BECIU,** University of Agricultural Sciences and Veterinary Medicine, Bucharest, Romania  
**Senior Lecturer Ph.D. Radu Lucian PÂNZARU,** University of Craiova, Romania  
**Senior Lecturer Ph.D. Gavrilă STEFAN,** University of Agricultural Sciences and Veterinary Medicine, Iasi, Romania  
**Prof. Ph.D. Vasile GOSA,** University of Agricultural Sciences and Veterinary Medicine of Banat Timisoara, Romania  
**Senior Lecturer Ph.D. Tiberiu IANCU,** University of Agricultural Sciences and Veterinary Medicine of Banat Timisoara, Romania  
**Senior Lecturer Ph.D. Ioan BRAD,** University of Agricultural Sciences and Veterinary Medicine of Banat Timisoara, Romania

**Publication Committee:**

**Lecturer Ph.D. Mariana Burcea, Eng. Teodora Popescu**

This volume includes the scientific papers presented at the International Conference “Agriculture for Life, Life for Agriculture”, June 4-6, 2015, University of Agricultural Sciences and Veterinary Medicine, Bucharest, Romania, Section 7: Management and Engineering in Rural Areas, Topics: Production economics, Farm management and marketing, Agricultural policies, Agribusiness and agricultural extension, Agritourism and Rural development, Environmental economics, Educational management in agronomic education and other connected areas.





## C O N T E N T S

---

### 1.TRENDS IN THE DEVELOPMENT OF ORGANIC FARMING IN BULGARIA

Valentina AGAPIEVA ..... 9

### 2.CONTRIBUTIONS TO THE DEVELOPMENT OF THE FIELD CROPS YIELD IN TEISANI AREA HOUSEHOLDS, PRAHOVA COUNTY

Cristina Elena ANGELESCU, Roxana HOROIAȘ..... 13

### 3.ASSESSMENT OF RURAL YOUTH INVOLVEMENT IN THE USAGE OF INFORMATION AND COMMUNICATION TECHNOLOGIES (ICTs) AMONG FARMERS’ IN OSUN STATE, NIGERIA

J. O. AYINDE, D. O. TORIMIRO, G. F. KOLEDOYE, O. A. ADEPOJU..... 17

### 4.TECHNICAL CONCEPTION OF FARMERS TO ECONOMIC POSSIBILITY OF EXPANDING OILSEED RAPE CULTIVATION IN NORTH-EAST OF IRAN

Mehdi AZIZI, Mohammad MAZHARI, Abbas FALLAH TOOSI..... 25

### 5.THE EVALUATION OF CHOLESTEROL CONCENTRATION IN EGG YOLKS CONTAINING OXYTETRACYCLINE RESIDUE

Silviu Ionut BEIA, Ioan Iulian ALECU, Violeta Elena BEIA..... 29

### 6.FOLIAR OR CHEMICAL FERTILIZERS FOR GARDEN PEAS

Ion BOZGA, Olimpia PANDIA, Ion SARACIN, Ioan Christi GANEA..... 33

### 7.EU FUNDS FOR THE ROMANIAN AGRICULTURE DURING 2007-2013. STUDY CASE MEASURE 121- STATISTICAL DATA AND PRACTICAL IMPLICATIONS

Aurelia Ioana BRÎNARU, Ion DONA..... 37

### 8.STUDY REGARDING THE EVOLUTION OF FOOD CONSUMPTION OF ROMANIA DURING 2007- 2013, FROM THE PERSPECTIVE OF FOOD SECURITY INSURANCE AND EXPORT AVAILABILITY GROWTH

Denisa BURCEA, Ion DONA..... 45

### 9.STUDY ON THE EVOLUTION OF THE HOP MARKET IN ROMANIA DURING THE PERIOD 2007-2014

Irina-Adriana CHIURCIU..... 53

**10.QUESTIONNAIRE ON FOREIGN LANGUAGE LEARNING STYLES FOR BUSINESS AND ENGINEERING STUDENTS**

**Suzana Carmen CISMAS, Claudia MIHALCEA-CODREANU, Gabriela ANDREIASU, Anca Gabriela DIACONU..... 57**

**11.ASPECTS OF EMPLOYMENT IN AGRICULTURE IN THE MAIN DEVELOPMENT REGIONS OF ROMANIA**

**Reta CONDEI, Agatha POPESCU, Aurelia BĂLAN, Valentina TUDOR ..... 67**

**12.GENERAL ASPECTS CONCERNING THE CLIMATE OF THE OLTENIA REGION. CASE STUDY: THE OLT COUNTY**

**Dana Maria (OPREA) CONSTANTIN, Elena COFAS, Iuliana ZAHARIA..... 75**

**13.INFRASTRUCTURE OF AGRIFOOD PRODUCTS QUALITY ASSURANCE IN THE REPUBLIC OF MOLDOVA - BRANCH AND EXPORT APPROACHES**

**Cornel COȘER, Sergiu CHILIMARI..... 81**

**14.THE ANALYSIS OF THE INTENTIONS TO CONTINUE THE STUDIES IN THE HIGHER EDUCATION. CASE STUDY.**

**Daniela CREȚU, Andrei Radu IOVA..... 87**

**15.SUSTAINABLE MANAGEMENT PLAN APPLICABLE FOR ECOTOURISM CERTIFICATION SYSTEMS**

**Romeo Cătălin CREȚU, Petrică ȘTEFAN..... 93**

**16.SUSTAINABLE DEVELOPMENT AND FOOD SECURITY IN THE CONTEXT OF AGRO-FOOD SECTOR OF MOLDOVA'S INTEGRATION INTO THE EUROPEAN UNION**

**Tatiana DIACONU..... 99**

**17.THE ANALYSIS OF THE AGRO-FOOD SECTOR TRADE OF THE REPUBLIC OF MOLDOVA AND THE EUROPEAN UNION: POSSIBILITIES AND LIMITS**

**Tatiana DIACONU..... 105**

**18.THE ROLE OF GROUND RENT IN ESTABLISHING THE AGRICULTURAL LAND PRICE**

**Ramona DOBRE..... 111**

<b>19.MANUFACTURING AND PERFORMANCE EVALUATION OF A COMPATIBLE UNIT TO PRODUCE ANIMAL FEED PELLETS</b>	
<b>Tarek FOUDA, Adel ELMETWALLI, O. KADDOUR, Asaad DERBALA, K. ABDEL-MOHSEN.....</b>	<b>119</b>
<b>20.MINIMIZE ENERGY AND COSTS REQUIREMENT OF WEEDING AND FERTILIZING PROCESS FOR FIBER CROPS IN SMALL FARMS</b>	
<b>Tarek FOUDA, Adel ELMETWALLI, Samier SHALABY, Amina ALBEB.....</b>	<b>127</b>
<b>21.THE SMALL AND MEDIUM ENTERPRISES AS THE BASIC COMPONENT OF THE ENTREPRENEURIAL ACTIVITY IN THE REPUBLIC OF MOLDOVA</b>	
<b>Liliana GRINCIUC.....</b>	<b>135</b>
<b>22.EFFECT OF VARIOUS INPUTS ON PADDY PRODUCTION - A COMPARISON OF ARTIFICIAL NEURAL NETWORKS AND LINEAR REGRESSION ANALYSIS</b>	
<b>Mohammad Ali HORMOZI, Abbas ABDESHAHI, Mohammad Amin ASOODAR.....</b>	<b>141</b>
<b>23.EDUCATION IMPACT ON THE RESULTS OBTAINED IN AGRICULTURE, IN THE SECONDARY SCHOOLS AND IN THE JURIDIC FIELD</b>	
<b>Roxana HOROIAS, Ana GAVRILESCU, Florentina ULMEANU.....</b>	<b>147</b>
<b>24.CURRENT SITUATION AND PROSPECTS OF THE LABOUR ORGANIZATION IN WINE AND GRAPE INDUSTRY IN THE REPUBLIC OF MOLDOVA</b>	
<b>Tatiana IAȚIȘIN, Tatiana COLESNICOVA.....</b>	<b>151</b>
<b>25.THE LIVING STANDARD AND DEVELOPMENT ANALYSIS THROUGH THE EVOLUTION OF GROSS DOMESTIC PRODUCT FOR THE PERIOD 2000- 2012</b>	
<b>Abdul Rahman IBRAHIM, Raluca NECULA, Diana Roxana CAPĂTĂ.....</b>	<b>155</b>
<b>26.THE ROLE OF FAMILY SOCIALIZING IN BUILDING GENDER IDENTITY</b>	
<b>Adina Magdalena IORGA.....</b>	<b>161</b>
<b>27.ECONOMIC ANALYSIS OF STATE AND DEVELOPMENT OF BEEKEEPING IN BULGARIA</b>	
<b>Vasko KOPRIVLENSKI, Violeta DIRIMANOVA, Valentina AGAPIEVA.....</b>	<b>167</b>
<b>28.MACROECONOMIC DETERMINANTS OF THE DYNAMICS OF INVESTMENT IN AGRICULTURE (CASE OF POLAND)</b>	
<b>Dariusz KUSZ, Stanisław GEDEK, Ryszard KATA.....</b>	<b>171</b>

**29.CHANGES IN THE RELATIONS OF PRODUCTION FACTORS IN AGRICULTURE (THE CASE OF POLAND)**

**Dariusz KUSZ..... 179**

**30.TRENDS OF WINE MARKET IN ROMANIA: COMPETIVENESS AND DEVELOPMENT OPPORTUNITIES IN THE CONTEXT OF MARKETS GLOBALIZATION**

**Georgiana-Raluca LĂDARU , Silviu BECIU..... 189**

**31.THE ROLE OF FRUIT GROWING IN THE DEVELOPMENT OF THE AGRI-FOOD SECTOR OF THE REPUBLIC OF MOLDOVA**

**Aurelia LITVIN, Ludmila DOBROVOLSCHI..... 193**

**32.THE PROBLEMS OF THE EXPORTERS FROM REPUBLIC OF MOLDOVA RELATED TO THE MANAGEMENT OF EXPORT PROMOTION**

**Aurelia LITVIN, Natalia DELIU..... 199**

**33.MANAGEMENT OF THE IRRIGATION SYSTEMS IN ROMANIA BETWEEN 1990-2014. STUDIES, PROJECTS, STRATEGIES**

**Aurel LUP, Liliana MIRON ..... 203**

**34.RESEARCH ON INFLUENCE OF AGROFUNDS ON THE FODDER PRODUCTION AT PREAJBA –GORJ**

**Dragoş Mihai MEDELETE, Radu Lucian PĂNZARU..... 213**

**35.EXTERNAL FACTORS' IMPACT OVER THE AGRICULTURAL SECTOR OF THE REPUBLIC OF MOLDOVA**

**Victor MOROZ, Anatolie IGNAT..... 217**

**36.STUDY ON THE INFLUENCE OF SEVERAL FACTORS ON THE RESULTS OF USING THE MEAT CHICKEN RAISING TECHNOLOGIES**

**Ioana NICULAE, Georgiana Melania COSTAICHE..... 227**

**37.ANALYSIS OF IMPROVED HOUSEHOLD SOLID WASTE MANAGEMENT SYSTEM IN MINNA METROPOLIS, NIGER STATE, NIGERIA**

**Akindele Michael OJO, Esther Ojonugwa OGBOLE, Olanike Alaba OJO..... 237**

**38.RURAL EMPLOYMENT GENERATION AND POVERTY ALLEVIATION THROUGH SMALL SCALE CASSAVA PROCESSING VENTURES IN NIGER STATE, NIGERIA**

**Olanike Alaba OJO, Alice INIJEZE, Akindele Michael OJO, Safiya JIBRIN..... 243**

<b>39. <i>MEDICAGO SATIVA</i> – FODDER-FOOD – NATURIST MEDICINE</b>	
Olimpia PANDIA, Ion SARACIN, Ion BOZGA, Ștefania Eliza TANASIE.....	251
<b>40.THE IMPACT OF INVESTMENT MANAGEMENT ON THE EVOLUTION OF THE AGRI-FOOD EXPORT IN THE REPUBLIC OF MOLDOVA</b>	
Svetlana PETRASCU.....	255
<b>41.ASSESSMENT OF GROUNDWATER QUALITY FROM BAIA MARE MINING AREA, ROMANIA</b>	
Ioana PIȘTEA, Cristina ROȘU, Carmen ROBA, Alexandru OZUNU.....	259
<b>42.THE EVOLUTION OF EXPORT AND IMPORT PRICES IN REPUBLIC OF MOLDOVA AND THEIR EFFECT ON THE ECONOMIC GROWTH</b>	
Daniela POPA.....	265
<b>43.RESEARCH ON LABOUR PRODUCTIVITY IN ROMANIA'S AGRICULTURE</b>	
Agatha POPESCU.....	271
<b>44.RESEARCH ON ROMANIA'S EMPLOYMENT IN AGRICULTURE AND ITS POSITION IN THE EUROPEAN UNION</b>	
Agatha POPESCU, Reta CONDEI.....	281
<b>45.THE IMPACT OF AGRICULTURAL EDUCATION SYSTEM ON THE IMPROVEMENT OF THE RURAL LABOUR MARKET SITUATION</b>	
Veronica PRISĂCARU, Tatiana SEVCIUC.....	291
<b>46.EDUCATIONAL MANAGEMENT IN THE FIELD OF LIFE SCIENCES - KEY COMPETENCES NEEDED TO START AND DEVELOP THE INNOVATIVE SME'S</b>	
Nicoleta RADU, Ana Aurelia CHIRVASE, Narcisa BABEANU, Ovidiu POPA .....	297
<b>47.EDUCATIONAL MANAGEMENT IN THE FIELD OF LIFE SCIENCES - BLENDING LEARNING FOR BIOENTREPRENEURS TRAINING</b>	
Nicoleta RADU, Ana Aurelia CHIRVASE, Narcisa BABEANU, Ovidiu POPA.....	301
<b>48.GROUNDWATER QUALITY IN A RURAL AREA FROM BUZĂU COUNTY, ROMANIA</b>	
Carmen ROBA, Cristina ROȘU, Ioana PIȘTEA, Alexandru OZUNU, Horia MITROFAN .....	305

<b>49.THE CONTROLLING USING TECHNICAL INSTRUCTIONS OF OPERATIONAL</b>	
<b>Titin Fittono RULIANA .....</b>	<b>311</b>
<b>50.THE LOCAL ORIGINAL REVENUE ANALYSIS OF EAST KALIMANTAN PROVINCE, INDONESIAN</b>	
<b>Titin RULIANA.....</b>	<b>315</b>
<b>51.EVALUATION OF ROMANIAN LIVESTOCK SECTOR FROM THE PERSPECTIVE OF AVAILABILITY OF FOOD PRODUCTS</b>	
<b>Mariana SANDU, Steliana SANDU, Marcel Theodor PARASCHIVESCU.....</b>	<b>321</b>
<b>52.EVOLUTIONARY BENCHMARKS OF AGRICULTURE AND RURAL DEVELOPMENT IN THE REPUBLIC OF MOLDOVA</b>	
<b>Olga SÂRBU.....</b>	<b>327</b>
<b>53.FINANCIAL MECHANISMS OF THE DEVELOPMENT OF THE AGRARIAN SECTOR IN THE REPUBLIC OF MOLDOVA</b>	
<b>Aliona ŞARGO, Elena TIMOFTI.....</b>	<b>337</b>
<b>54.COMPARISON OF DEVELOPMENT EFFORTS MADE BY DIFFERENT AGENTS IN RURAL ANKARA: ANKARA DEVELOPMENT AGENCY CASE</b>	
<b>Coşkun ŞEREFÖĞLU, Gökhan YALÇIN.....</b>	<b>341</b>
<b>55.PRACTICAL ASPECTS RELATED TO THE ACCOUNTING OF FOREIGN CURRENCY MARKETING IN THE LICENSED BANKS OF THE REPUBLIC OF MOLDOVA</b>	
<b>Tatiana ŞEVCIUC, Veronica PRISĂCARU.....</b>	<b>349</b>
<b>56.THE IMPACT OF GOVERNMENT INTERVENTION ON AGRICULTURAL INDUSTRY: A CASE STUDY IN THE ISRAELI RAW MILK INDUSTRY</b>	
<b>Tal SHAHOR, David DRORY.....</b>	<b>355</b>
<b>57.GREENHOUSE GASES: CAUSES, LOSSES AND REMEDIAL MEASURES FOR SUSTAINABLE AGRICULTURE</b>	
<b>P. S. SHEHRAWAT, Rati MUKETSHWAR.....</b>	<b>363</b>
<b>58.AGRICULTURAL WASTE AWARENESS AND UTILIZATION FOR HEALTHY ENVIRONMENT AND SUSTAINABLE LIVELIHOOD</b>	
<b>P. S. SHEHRAWAT, Nitu SINDHU, Parmila DEVI.....</b>	<b>371</b>

<b>59.THE STRATEGIC MANAGEMENT AS A PRIMORDIAL FACTOR TO OBTAIN PERFORMANCE IN AGRONOMIC HIGHER EDUCATION IN REPUBLIC OF MOLDOVA</b>	
<b>Adrian SÎRBU.....</b>	<b>377</b>
<b>60.RESEARCH ON THE ECONOMIC DEVELOPMENT OF SOUTH-WEST OLTENIA REGION</b>	
<b>Elena SOARE, Iuliana DOBRE .....</b>	<b>383</b>
<b>61.COMPETITIVENESS OF BULGARIAN VEGETABLE PRODUCTION AFTER THE EU ENLARGEMENT</b>	
<b>Teodora STOEVA.....</b>	<b>391</b>
<b>62.PREREQUISITES AND CONDITIONS FOR THE DEVELOPMENT OF BULGARIAN AGRICULTURE AND VEGETABLE PRODUCTION – CURRENT SITUATION, ISSUES AND PRIORITIES IN THE CONTEXT OF THE CAP</b>	
<b>Teodora STOEVA.....</b>	<b>397</b>
<b>63.AT THE BEGINNING OF A NEW REGIONAL STRATEGY BASED MOSTLY ON GROWTH. 2020 EUROPE STRATEGY- TARGET ON POVERTY</b>	
<b>Roxana STOIAN.....</b>	<b>401</b>
<b>64.TRENDS TO PROMOTE EXPORT OF LOCAL AGRICULTURAL AND FOOD PRODUCTS UNDER THE CONDITIONS OF EUROPEAN ECONOMIC INTEGRATION</b>	
<b>Elena TIMOFTI, Ghenadie TIMOFTI.....</b>	<b>405</b>
<b>65.THE SPATIAL CONCENTRATION AND SPECIALIZATION OF AGRICULTURAL PRODUCTION IN EU</b>	
<b>Agnieszka TŁUCZAK.....</b>	<b>411</b>
<b>66.IMPROVING THE SYSTEM OF PUBLIC SUPPORT AND MECHANISMS TO STIMULATE INNOVATION IN AGRICULTURE</b>	
<b>Liudmila TODOROVA.....</b>	<b>417</b>
<b>67.STRUCTURAL CHANGES AND ECONOMIC RESILIENCE IN ROMANIAN AGRICULTURAL MANAGEMENT</b>	
<b>Monica Mihaela TUDOR.....</b>	<b>423</b>

**68.COMPETITIVENESS AND PROFITABILITY OF SUDANESE GUM ARABIC  
IN NORTH KORDOFAN STATE**

**Ghada A. M. YASSEEN, Adil Y. ELJACK, Mohhamed E. D. AHMED,  
Aladdin E. HAMAD..... 429**

**69.MIGRATION FROM RURAL AREAS - ITS IMPACT AND PROSPECTS**

**Silvia ZAHARCO..... 435**

**70.ASSERTIONS ON THE CHARACTER OF NASCENT MANAGERS AND  
ENGINEERS WITHIN THE PERSONALITY'S INVESTIGATION BY THE  
WELTANSCHAUUNG – EGO QUESTIONNAIRE**

**Iuliana ZAHARIA, Elena COFAS, Dana Maria CONSTANTIN (OPREA)..... 439**



## TRENDS IN THE DEVELOPMENT OF ORGANIC FARMING IN BULGARIA

**Valentina AGAPIEVA**

Agricultural University – Plovdiv, Department of Management and Marketing, Plovdiv 4000, 12 Mendeleev Blvd, Plovdiv, Bulgaria, Phone: +359 32 654 435, Email: vagapieva@au-plovdiv.bg

*Corresponding author:* vagapieva@au-plovdiv.bg

### **Abstract**

*The purpose of this article is to follow trends in the development of organic farming in Bulgaria, and to identify the factors' strength and direction of their impact on organic production of agricultural products. The study covers the period from 2003 to 2013 and is based on information from official statistics of the Ministry of Agriculture and Food, and the author's own research. There are distinct rates of increase in both areas and organic agricultural production in Bulgaria. While in 2003 the areas under organic management are 8,364 ha by 2013 they numbered 56, 287 ha. Bulgaria has a high potential for production and export of organic agricultural products fresh and processed, but significantly lags behind other European countries. However, there is increasing momentum in organic farming, driven by a group of economic, market, social and legislative initiatives. The main reason for this growth is consumer demand of organic products in Bulgaria. In general, the motivations of Bulgarian consumers of organic products are related to the benefits for health and the environment, to the improvement of food quality and to the support of local small farmers, communities and markets.*

*Key words:* areas, Bulgaria, factors, organic production, trends

### **INTRODUCTION**

Organic farming as a way of thinking and practice is originated in the early years of the 20th century with the application of various alternative methods of agricultural production. The method of organic farming is practiced in approximately 100 countries and agricultural areas under organic management are constantly increasing [9].

Bulgaria is one of the most biologically rich countries in Europe. The severe soil fertility and water purity is a prerequisite for the successful development of the organic agricultural products.

Therefore, the producers involved in organic production guideline and actively seek ways of rational use of this potential through organic farming methods for overlapping economic and social issues of this agricultural system with the environment.

In accordance with this facts, the main goal of our study is to trace the condition and development of organic farming in Bulgaria.

### **MATERIALS AND METHODS**

The trends in organic production in Bulgaria

during the period 2003-2013 are revealed by analysis of factors affecting the development of organic farming in Bulgaria, a conditions and changes of the areas under organic management, a production of biological crop and livestock, and also economic, social and legislative initiatives for this period [1].

Achieving its purpose, the study includes official statistics of the Ministry of Agriculture and Food of the Republic of Bulgaria, as well as the author's own research.

### **RESULTS AND DISCUSSIONS**

One of the biggest challenges for Bulgaria in the process of economic restructuring and implementation of organic production is to ensure a balance between sufficient food production, to increase employment and preventive protection of the environment.

According to the official information from Department of Agroecology of Ministry of Agriculture and Food in Bulgaria, the distribution of areas under organic management during the period 2003-2013 is significantly increasing (Table 1).

Table 1. Amendment of areas under organic farming in Bulgaria during the period 2003-2013 (ha)

	ha
2003	8,364
2004	12,284
2007	13,646
2008	16,663
2009	12,321
2010	25,648
2011	26,622
2012	40,378
2013	56,287

Source: Department of Agroecology of Ministry of Agriculture and Food in Bulgaria

The information submitted by the supervisory authorities shows that at the end of 2013 the total areas under organic agricultural method amounts to 56,287 ha, which accounts for 0.006% of the UAA. The comparison with data from 2003 shows that the areas are highly increased.

The most preferred organic crops by farmers are plantations, industrial crops and cereals (Fig. 1).

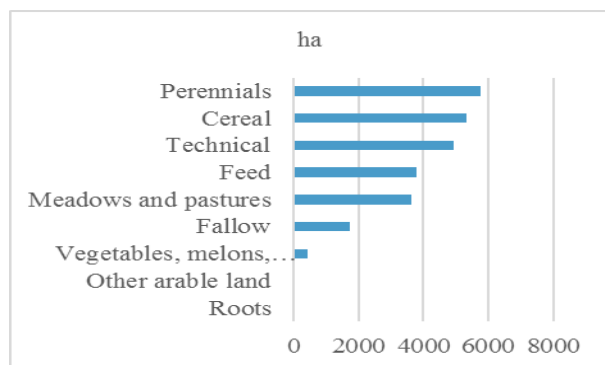

Fig. 1. Areas of organic crops in Bulgaria during the period 2003-2013 (ha)

Source: Own research

The number of animals kept by the methods of organic farming in Bulgaria also is growing up. In the studied period, we saw that the number of sheep and goats fell slightly, while the number of cattle and bee colonies has a considerable growth. (Table 2).

As a result of the increase in the number of bee colonies in 2013 was an increase in the amount of organically produced honey from the previous year - from 2,448 tons in 2012 to 2,718 tons in 2013.

Undoubtedly, Bulgaria is a traditional producer of various types of certified organic honey with excellent quality indicators, as

much of the production is exported to the world market.

Table 2. Organic livestock in Bulgaria during the period 2003-2013 (number of animals)

	Cattle	Sheep	Goat	Bee colonies
2008	470	2,471		
2009	272	5,831	2,732	41,089
2010	364	6,698	2,773	46,429
2011	976	6,648	3,397	58,855
2012	1,173	9,175	2,831	85,346
2013	1,311	7,894	3,235	117,360

Source: Own research

Bulgaria is also the largest producer of organic rose oil in the world, one of the largest exporters of organic cucumbers in Europe, second in the European union by the size of certified organic properties for collection of wild fruits, herbs and mushrooms, and also fourth in the European union in the number of certified organic bee colonies.

The main reason for the changes in organic farming is not only overproduction of subsidized crops, but increased sensitivity of European countries to protect the environment, biodiversity and animal welfare [9].

In accordance with the results from our own research in a few of organic farms during the period, we found both the general and average yields of organic produce in different crops (Table 3).

Table 3. Organic production in organic Bulgarian farm during the period 2003-2013 (kg/da)

Organic production	Area (da)	Average yield	Total yield
Wheat	20	400	8,000
Sunflower	20	180	3,600
Tomatoes	2	3,500	7,000
Pepper	2	3,900	7,800
Cucumbers	2	2,500	5,000
Apples	10	1,600	16,000
Peaches	10	1,800	18,000

Source: Own research

On the one hand, organic production of fruits such as apples and pears occupies quite a high proportion of total organic agricultural production. On the other hand, vegetables such as tomatoes and peppers have

satisfactory yield, despite their smaller areas.

The assessment of factors influencing the development of the organic sector in Bulgaria is of utmost importance. Certainly, growing export demand, especially from European consumer subsidies for the organic production and favorable government policy, and the national legal framework have the greatest influence.

The negative factors on organic farming and marketing are the lack of awareness of organic products quality, lack of marketing strategy and advertising, and strong competition from imported organic products.

In our opinion, after the accession of Bulgaria to the European Community, a considerable progress is established.

Definitely, Bulgaria need large investments for marketing and advertising. Because the achievement of open and competitive international market cannot rely just on the organic products quality.

Bulgarian organic farming is helped by the Ministry of Agriculture and Food, which supports the creation of a single legal basis for organic crop production, livestock and establishment of an adequate certification system. Thus, more and more farmers are turning to organic production. However, bulgarian organic production is enshrined as a priority in the government of the country. Among the recommendations in the new national policy on organic farming is to use European subsidies to shift from export of biological raw materials to manufacturing final organic products, such as removal of cosmetics rather than essential oils or dried herbs.

In the same time, the market niche of organic products aroused the interest of consumers, as the latter does not want to be misled by faulty products bearing the risk of contamination with pesticide residues, nitrates, GMOs, etc.

In accordance with above facts, the number of operators and areas in the control system in Bulgaria is growing substantially (Fig. 2).

In 2013, control of compliance with the rules of organic production of agricultural products and foodstuffs and designate them according to the requirements of Regulation (EU) № 834/2007 and national legislation are carried

out 11 control bodies, whereas in the beginning of period were about 4. These requirements aimed to improve legislation in the field of organic production both in Europe and in Bulgaria.

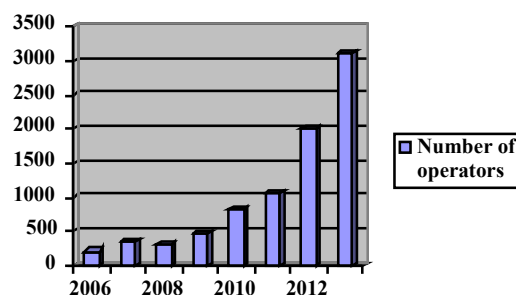

Fig. 2. Number of organic operators in Bulgaria during the period 2003-2013

Source: Vitoshka Research, 2009

The legal basis in Bulgaria includes two ordinances – No 22 from 4 July 2001, for organic crops, crop products and foodstuffs of crop origin and thereto on them; No 35 from August 30, 2001, for organic farming and organic livestock, animal products and foodstuffs of animal origin and thereto on them.

There is still no official statistics on trade in organic products. However, about 90% of currently produced certified organic production in Bulgaria is exported mainly to Western European countries (essential plants and herbs, vegetables, honey).

The share of realized Bulgarian organic products on the national market is about 1%, because it is at the stage of inception over the last decade [7].

Therefore, the Ministry of Agriculture and Food in Bulgaria is working to ensure the implementation of state policy in the field of supervision and control of organic production. The institution, also aims to comply with both the European requirements and national legislation.

Moreover, there is a created plan for improving the possibilities for supporting organic producers and promoting the benefits of organically produced foods and products for human health, and to prevent the environment and natural resources [2].

Since, Bulgaria is one of the European

countries with the richest biodiversity with a variety of natural resources (uncontaminated soil, suitable climate, established regulations), we think that its rapid and extensive development of organic farming is on the right direction.

## CONCLUSIONS

First, organic farming in Bulgaria is at an early stage of development, but with a very large potential ahead.

Second, the rapid development of organic agriculture in the last 20 years driven by the pressure of market forces and increased consumer demand, prompted organic farmers in Bulgaria to seek equivalent alternatives to conventional farming.

Third, there are clearly identified and outlined positive trends of increasing the number of organic operators and organic farming area, amount of space in the control system and increasing the organically grown crops and livestock in Bulgaria.

## ACKNOWLEDGEMENTS

The study is financed by the Fund "Scientific Research" of the Agricultural University – Plovdiv, Bulgaria.

## REFERENCES

- [1]Ministry of Agriculture and Food, Department of Agroecology Bulgaria
- [2]National Plan for Development of Organic Agriculture in Bulgaria in the period of 2006-2013: 71-108
- [3]Ordinance No 22 of 4 July 2001 on organic production of plants, plant products and food of plant origin and meant thereon, Head Four, Section 1
- [4]Ordinance No 35 of 30 August 2001 on organic farming and organic production of livestock products and foodstuffs of animal origin and indications referring thereto on (Title. - SG. 13 of 2006), Head Two Section 1-2-8: 6-92
- [5]Production, distribution and consumption of organic products in Bulgaria, Sofia, Vitosha Research, 2009
- [6]Programme for Rural Development 2007-2013: 76-96
- [7]Project "Limitation of spread of food to misleading information on organic products", Bulgarian Association "Active Users" Foundation for Organic Agriculture "Bioselena", Article "Not fake organic

food", 2007

[8]Regulation № 834/2007

[9]Willer, Helga and Lukas Kilcher, (Eds.). 2012. "The World of Organic Agriculture – Statistics and Emerging Trends 2012." Research Institute of Organic Agriculture (FiBL), Frick, and International Federation of Organic Agriculture Movements (IFOAM), Bonn: 216-220

## CONTRIBUTIONS TO THE DEVELOPMENT OF THE FIELD CROPS YIELD IN TEISANI AREA HOUSEHOLDS, PRAHOVA COUNTY

Cristina Elena ANGELESCU<sup>1</sup>, Roxana HOROIAS<sup>2</sup>

<sup>1</sup>University of Agronomic Sciences and Veterinary Medicine of Bucharest, 59 Mărăști Blvd, District 1, 011464, Bucharest, Romania, Phone: +4021.318.25.64, Fax: + 4021.318.25.67, Email: cristina.elena.angelescu@gmail.com

<sup>2</sup>AGROVET SA, 20 Siriului Street, District 1, 014354, Bucharest, Romania, Phone: +4021.20.80.300, Fax: + 4021.20.80.310, Email:roxana.horoias@gmail.com

**Corresponding author:** cristina.elena.angelescu@gmail.com

### Abstract

*The aim of the paper was to analyze the technological performance of the field crops on luvisols in Teisani area, Prahova County, where corn and potato are cultivated for personal consumption and beet for animal nutrition. The cultivation of wheat and fodder plants has been an exception. Studies conducted have firstly referred to the introduction of crops in rotation system, through cooperation and exchange between households and within their own household for those with larger surfaces. To compare the productivity of crops, the yield energy value has been used as a measure unit, which facilitates the comparison. The yields was reduced up to the lower limit of crop potential because of monocultures and the lack of appropriate technologies, even for small farming machinery. The results showed that using improved technologies, in 2013 and 2014, the yields were significantly superior, the highest ones, for potatoes and alfalfa, the last one as jumper field. Introducing alfalfa in the crop rotation system has led to the potato yield doubling, but also of those of wheat, corn and beet. Using manure and organic material available and degradable in the form of compost made in their own household, to which are added small amounts of nitrogen and phosphorus, there were obtained average yields by 40% higher than the average of the experience and by 139%, i.e. 2.4 times higher than the unfertilized variant, very much used in the area. Therefore, it was demonstrated, that there are huge resources to produce agricultural products and primary food in the Teisani rural area. Small peasant households should be encouraged and financially supported to participate to food production both for their own consumption, but also for the market.*

**Key words:** agricultural crops, fertilization, management, peasant household

### INTRODUCTION

In the Teisani area, the experiment was organized on luvisols type soils. Total agricultural surface used in the experiment was 2,253 ha [8], of which the arable land represented 478 ha. The cultivated surface with various crops was: wheat = 31 ha, corn = 188 ha, potato = 50 ha, alfalfa = 66 ha, and beet = 20 ha.

The remaining agricultural land was cultivated with vegetables, fruit trees, pastures, shrubs, other crops etc.

The following yields of the main crops were obtained: wheat = 1.5-1.6 t/ha, potato = 4.2 t/ha, beet = 5 t/ha, corn = 1.4 t/ha, and alfalfa = 15 t/ha.

Our study took into consideration the possibility of agricultural technologies optimization and the development of a

management that is going to bring a significant yield increase on this type of soil and, therefore, the small farming agriculture will have a higher contribution to the rural areas development [2].

Given the plots pronounced splitting into small lots, it was also taken into account the possibility of collaboration between households, in order to form some suitable provide crop rotations for the research purpose. The surveys conducted among householders have led to the finding that the locals have mostly used monoculture in all crops, at this moment the soil being at its physical and biological resistance limit, luvisols having, by definition, a medium to low fertility [6] [3].

Our working hypothesis proposed itself to think, to experiment and to implement a crop rotation system which is going to led to yields higher than double as now into the area.

**MATERIALS AND METHODS**

Taking into account the negative effects of monocultures [4], we focused to a crop rotation system consisting of five economically important crops, namely: 1. winter wheat; 2. corn; 3. beet; 4. potato; 5. alfalfa – jumping field. It is replaced by deep plowing at every 4 years.

Cultures haven't been arranged in the field according to the experimental technique requirements, but treatments have been made on different plots and to different owners.

Each of these five crops from the presented crop rotation has received six fertilization variants, which were established according to the researches previously conducted in this regard [1][5][7]: V1 – control, unfertilized; V2 – 20 t/ha own compost; V3 – 20 t/ha own organic matter; V4 – 100 kg/ha NPK (32 + 32); V5 – 20 t/ha compost + 100 kg/ha NP (18 + 18); V6 – 20 t/ha organic matter + 100 kg/ha NP (18 + 18).

Alfalfa also received the same treatment, for comparison.

Soil tillage, seeding, maintenance and harvesting works were the usual ones in the area, they not being the subject of our study.

Comparative studies and statistical calculation were carried out on the energetic equivalent of each crop, otherwise the comparison between them it wouldn't have been possible.

The transforming coefficients in energetic equivalent for each crop are the following ones: wheat = 375,000 kcal/ha; corn = 396,000 kcal/ha; beet = 206,000 kcal/ha; potato = 800,000 kcal/ha; and alfalfa = 345,000 kcal/ha.

The statistical calculations were performed by bifactorial analysis of variance, regressions and correlations analysis.

**RESULTS AND DISCUSSIONS**

Climatic conditions of the two years (2013 and 2014) were similar, so that the energy production were close to an average of 370,150 kcal/ha = 370.15 x 10<sup>3</sup> kcal/ha, i.e. ≈ 4 % deviations for each year (Table 1).

Table 1. Unifactorial analysis of the average energy produced by the agricultural crops from Teisani in each of the study years (original)

Years	Average (kcal/ha x 10 <sup>3</sup> )	Average ratio (%)	Difference (kcal/ha x 10 <sup>3</sup> )	Significance
2013	384.17	103.79	14.02	
2014	356.14	96.21	-14.01	
<b>General average: 370.15 x 10<sup>3</sup> kcal/ha</b>				

The variations were insignificant and placed within the confidence interval on the risk of 95% (also see Fig. 1).

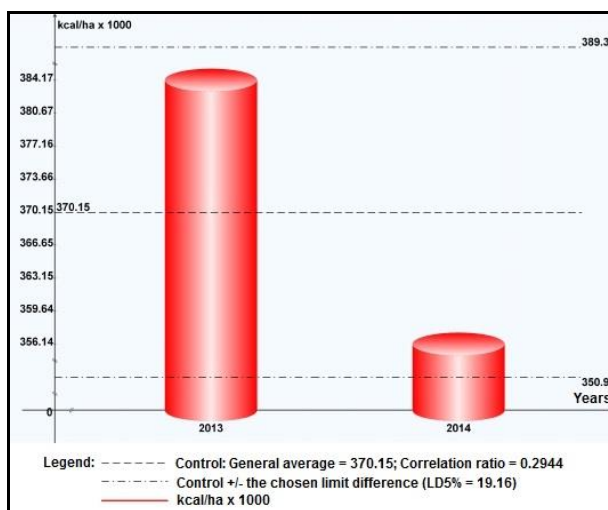

Fig. 1. Graphical representation of the average energy evolution produced by the agricultural crops from Teisani in the years 2013 and 2014 (original)

Fertilization factor, however, was decisive for observing the crops characteristics, their response being different (Table 2).

Table 2. Unifactorial analysis of the fertilization role in the energy production processes in the agricultural crops from Teisani, in average for the study years (original)

Fertilization	Average (kcal/ha x 10 <sup>3</sup> )	Average ratio (%)	Difference (kcal/ha x 10 <sup>3</sup> )	Significance
V1	216.17	58.40	-153/98	o o o
V2	419.75	113.40	49.60	*
V3	305.77	82.61	-64.38	o o
V4	424.68	114.73	54.52	*
V5	518.12	139.97	147.97	* * *
V6	336.45	90.89	-33.70	
<b>General average: 370.15 x 10<sup>3</sup> kcal/ha</b>				

Compared to the general average, the unfertilized version detaches itself very significantly negative. The best option for the average of all crops was V5 – 20 t/ha compost + NP (18 + 18), followed by V2 – 20 t/ha compost applied single, in autumn.

The results are presented in Fig. 2, where one



can found a correlation ratio of 0.75 and a correlation coefficient of

$$r = \sqrt{r^2} = \sqrt{0.75} = 0.87.$$

The mentioned production function is also a very significant one.

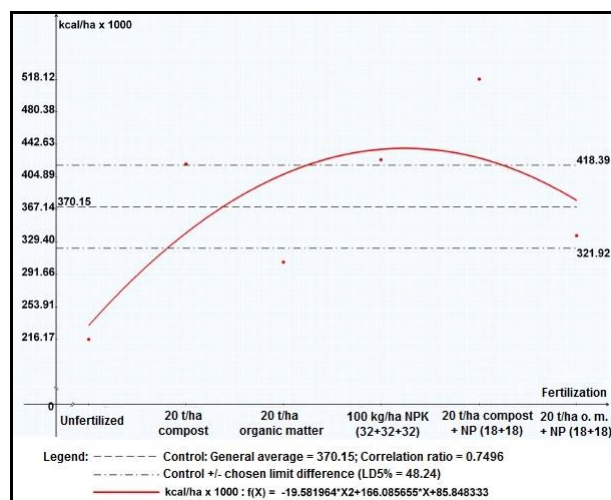

Fig. 2. Graphical representation of the fertilization influence on the energy produced by the agricultural crops, in average for 2013 and 2014 (original)

The monofactorial analysis of the most efficient culture in the area is shown in Table 3 and Fig. 3, from which it resulted that the most effective crop in the region and in average is the alfalfa, with 744.81 x 10<sup>3</sup> kcal/ha, followed by potato, with 689.84 x 10<sup>3</sup> kcal/ha. In descending order were the crops of beet, corn and wheat.

Table 3. Unifactorial analysis of the role of each culture from the crop rotation system in producing energy – Teisani, average for the study years (original)

Crops	Average (kcal/ha x 10 <sup>3</sup> )	Average ratio (%)	Difference (kcal/ha x 10 <sup>3</sup> )	Significance
Wheat	119.97	32.41	-250.18	o o o
Corn	125.43	33.89	-244.72	o o o
Beet	170.73	46.12	-199.42	o o o
Potato	689.84	186.37	319.69	* * *
Alfalfa	744.81	201.21	374.65	* * *
<b>General average: 370.15 x 10<sup>3</sup> kcal/ha</b>				

On average for the both years, the bifactorial analysis between the crop rotation system and the level of fertilization is shown in Fig. 4.

From Fig.4., there were noticed the following aspects:

(i)Especially for alfalfa and potato, the fertilization version with 20 t/ha compost + NP (18+18) obtained the highest yields and

significantly positive, the next ones being the simple one with 20 t/ha compost and the one only with chemical fertilizers (NPK).

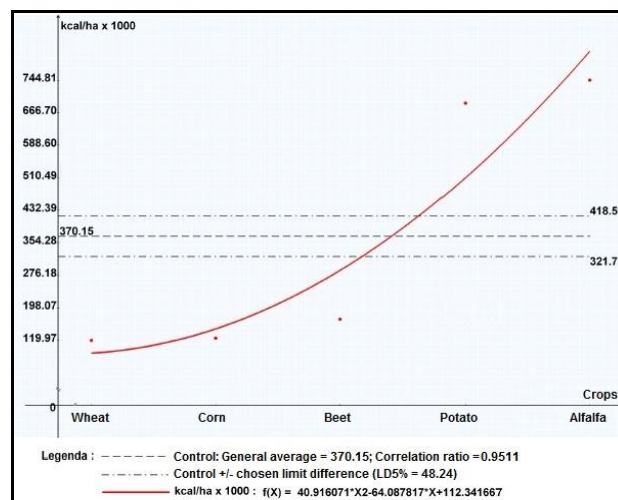

Fig. 3. Graphical representation of the crop rotation influence on the energy produced by the agricultural crops, in average for 2013 and 2014 (original)

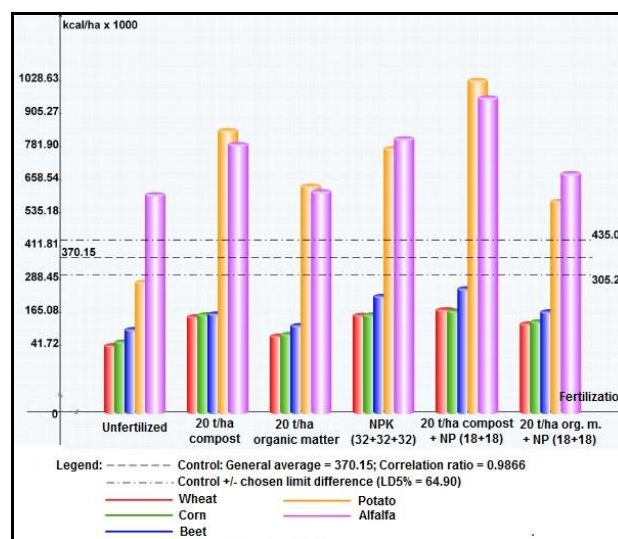

Fig. 4. Graphical representation of the fertilization and crop rotation influence on the energy produced by the agricultural crops, in average for 2013 and 2014 (original)

(ii)Wheat, corn and beet crops had a weaker reaction to fertilization, so that their yields were situated closer to the control variant.

(iii)Therefore, the local resources (straws, scraps, waste) of which compost could be achieved, are a very convenient and cheap alternative, available to every producer. It could even lead to a 3 times increase for the potato yield and a 2-3 times for the alfalfa yield.

## CONCLUSIONS

Bringing back the small producers from the hill and mountain regions to the commercial agricultural circuit is a goal of the European policy and an unfulfillment of the local rural policies. Yield level (but also the technology level) is an extremely low one and, frequently, it not even covers their consumption needs.

In the research area (Teisani) it was implemented a dispersed experience regarding the possibility of introducing a collective crop rotation system (more landowners) and of using some local resources and industrial manufactured inputs for increasing the harvests up to the region's climatic potential.

It has been working for two years, 2013 and 2014, using a crop rotation system with jumper field, namely wheat – corn – beet – potato – alfalfa, but also six graduations of fertilization.

The two years were similar from climatic point of view and they have achieved, in average, yields' energetic levels insignificant differentiated compared to the experience average. It is however visible a very significant increase of harvest's energy at 20 t compost/ ha + 100 kg/ha NP (18 + 18) and slightly significant for the versions 20 t compost/ ha and NPK (32+32+32). The non-composted organic matter, in any of the variants, hasn't brought the expected increases.

Most valuable crops in terms of energy are alfalfa and potato, followed by wheat and corn, beets being the last of them.

The presented concept doesn't serve only to the yield level growth with 2-5 times, but also to a most welcomed ecological system. All organic wastes can be permanently brought to the household' fermentation pit, supporting the hygienisation of the entire household.

## REFERENCES

- [1] Basso B., Ritchie J.T., 2005, Impact of compost, manure and inorganic fertilizer on nitrate leaching and yield for a 6-year maize-alfalfa rotation in Michigan. *Agriculture, Ecosystems & Environment*, Vol. 108, Issue 4, pp. 329-341
- [2]Berca, M. et al., 2014, Management issues of the corn crop on the eutricambosols from Brebu area

(Prahova County). *Scientific Papers „Management, Economic Engineering in Agriculture and Rural Development”*, Vol. 14(3):31-34,

[3]Berca, M., 2008, *Probleme de ecologia solului*. Ed. Ceres, Bucuresti

[4]Berca, M., 2011, *Agrotehnica, transformarea modernă a agriculturii*. Ed. Ceres, Bucuresti

[5]Eghball, B., Power, J.F., 1999, Phosphorus- and Nitrogen-Based Manure and Compost Applications Corn Production and Soil Phosphorus. *Soil Science Society of America Journal*, Vol. 63(4):895-901

[6]Mihalache, M., Ilie, L., 2008, *Pedologie - Solurile României*. Ed. Dominor, București, 63-67

[7]Oppermann, R., 2003, Nature balance scheme for farms-evaluation of the ecological situation. *Agriculture, Ecosystems & Environment*, Vol. 98, Issue 1-3, pp. 463-475

[8]Teisani Page – Istoric, <http://teisani.page.tl>



## ASSESSMENT OF RURAL YOUTH INVOLVEMENT IN THE USAGE OF INFORMATION AND COMMUNICATION TECHNOLOGIES (ICTs) AMONG FARMERS' IN OSUN STATE, NIGERIA

J. O. AYINDE, D. O. TORIMIRO, G. F. KOLEDOYE, O. A. ADEPOJU

Obafemi Awolowo University, Department of Agricultural Extension and Rural Development, Ile Ife, Nigeria, Phones: +2348035719389, +2348033953651, +2348035603497, Emails: tundeyjoy@yahoo.com, torimiro@gmail.com, gbengakoledoye@gmail.com

*Corresponding author:* tundeyjoy@yahoo.com

### Abstract

*This study assessed rural youth involvement in the use of Information and Communication Technologies (ICTs) in agriculture in Osun State, Nigeria. Specifically, it examined awareness and analysed attitude of rural youths in the use of ICTs to disseminate agricultural information. A multi-stage sampling procedure was used to select one hundred and twenty respondents for the study. The data were collected using structured interview schedule and analysed using descriptive and inferential statistics. The mean age of respondents was 18.0 years. Also, 71.7 percent of the respondents scored high in ICTs awareness in relation to agriculture. Telephone (56.0%) was commonly used as a mean of passing agricultural information among the youths and the level of computer/literacy was slightly above average (58.3). Result of the correlation analysis shows that there was a positive and significant relationship ( $r = 0.481$ ;  $p > 0.05$ ) between the awareness of the usage of ICTs in agriculture and their attitude toward the use of ICTs. The study therefore concluded among others, that rigorous awareness on the importance of ICTs in farming should be created among youths in Osun State in order enhance and bring about positive solutions to agricultural development stakeholders efforts in combating food insecurity in Nigeria.*

**Key words:** information and communication technologies (ICTs), information dissemination, involvement, rural youth

### INTRODUCTION

The poor image of persons involved in agriculture needs to be changed and the young people are the ideal catalysts for such change given their greater propensity and willingness to adopt new ideas, concepts and technology which are all critical to changing the way agriculture is practised and perceived. The term “youth”, according to the United Nations refers to people who are aged between 15 and 24 years. In the Third World countries, about 20 percent of the population belongs to this age group. Rural youth account for 55 percent of the world. [10]

Youths are defined as the people within the ages of 13-30 years. These people constitute about 32 percent of the Nigerian rural communities. The oxford dictionary describes the youth as the period between childhood and adult age. [5]

Qualities of vigour, freshness, immaturity and so on are associated with youth (being youth).

They are agents of change when given the opportunity in a community. [4]

Rural youth, therefore, should be brought into the mainstream of the rural development process in general and agricultural development in particular if the problem of food insecurity is to be solved in Nigeria.

Communication of agricultural information to the farmers is an important input for agricultural development. [6]

It is generally assumed that only the farmers of higher socio-economic status are availed the opportunity of receiving information from the different sources. The greater task before the extension worker is to provide agricultural communication to a large number of illiterate and poverty stricken people who constitute a major portion of the farming population. In order to reach a large, heterogeneous and anonymous group of people, two important media: print and electronic are significantly important.

The absence of functional agricultural

information delivery system is a major constraint to agricultural development in Nigeria. [4]

Non-provision of necessary agricultural information was identified as a key factor limiting agricultural development in Nigeria. [2]

Also, lack of access to relevant agricultural information by farmers in developing countries cuts across all subsectors of agriculture and different stages of agricultural production process. [9]

Farmers need to be informed and educated about improved agricultural practices to enable them increase their productivity and income. Several channels such as extension agents, individuals, farmer-to-farmer contact, print media (newspapers, magazines, newsletters, leaflets, pamphlets, and posters) and electronic media (radio, television, film, slides and film strips) have been widely used to disseminate information to farmers. [8] and [7]

The required amount of information and learning is, however, so vast that only effective use of the information multipliers, the mass media, can provide information at the rates driven by pressure of time, population, geographical constraints, and shortage of trained extension personnel in developing countries.

As it becomes necessary and vital to facilitate food and nutrition security, there is the need to encourage the youths especially those in the rural community to participate well in agriculture, knowing how the economic, social and cultural contexts of agriculture are changing fast, as evidenced by significant shifts in the patterns of food production and consumption. An increasingly globalised world also means that there is now greater access to fast-evolving communication and media technology, which improves information flow and adds to the feeling that the world is getting smaller. However, development and growth processes still move at different speeds in different locations, even within countries. These inequalities are increasingly visible to people living in remote rural areas, often characterised by under-investment, especially in ICTs and this results in slow growth with high consequence on the

state of food security in these areas. [4]

Thus, literature has revealed that youths have been characterised by innovation proneness, faster reaction time, minimal risk aversion, faster rate of learning, greater knowledge acquisition propensity but little has been said about exploiting these characteristics in the use of ICTs in Agriculture. [1] and [4]

Hence, the study seeks to assess rural youth involvement in the use of information and communication technologies (ICTs) in agriculture in Osun State, Nigeria. Specifically, it described the demographic characteristics of the rural youths, analysed the rural youth level of awareness of ICTs in disseminating agricultural information, examined the common ICTs equipment used and described the youth perception to the ICTs use in the study area.

## MATERIALS AND METHODS

**The study area** was carried out in Osun State which is located in South-Western Nigeria with an area of approximately 8,882.55 square kilometres. It lies between longitude 4° to the west and longitude 5°4' to the East. The vegetation of the State runs through secondary forest and derived savannah with natural lowland tropical rain forest vegetation with an average of 152mm per annum rainfall. The state is divided into three administrative zones, thirty Local Government Areas (LGAs) with an area office in Modakeke. The selected Local Government areas were located within the three administrative zones.

**Primary and secondary data** were used for the study.

**The population of the study** was youth aged between 13 and 30 years.

**A multi stage sampling procedure** was adopted. First, proportionate sampling technique was used to randomly select five (5), four (4) and three (3) Local Government Areas (LGAs) from the three Agricultural Development Programme zones viz: Osogbo zone; Ife-Ijesha zone; and Iwo zone, respectively. In all, twelve (12) LGAs representing about 40 percent of the total LGAs (30 LGAs) in the state was selected. In

the second stage, a purposive sampling technique was used to select one rural community in each LGA selected. In all, twelve (12) rural communities were selected. In the last stage, snow-ball sampling technique was used to compile a list from which 10 respondents (secondary school students) were selected in each rural community selected for the study, making a total of 120 respondents. The data were collected using structured questionnaires. The dependent variable was the respondents' perception of ICTs use. This was determined by asking the respondents 10 perceptual questions on a five point scale of: Strongly Agreed (5), Agreed (4), Undecided (3), Disagree (2) and Strongly Disagree (1). Data collected were analysed using descriptive statistics such as frequency counts, percentages, mean, standard deviation, bar-chart and pie-chart while chi-square and correlation analyses were used to make deductions. Level of awareness of ICTs use was rated on a three point scale of high,

moderate and low using mean plus and minus standard deviation.

## RESULTS AND DISCUSSIONS

### Demographic characteristics of youths

Results in Table 1 shows that 1.6 percent of the respondents were within the age group of 16-20 years, while 1.6 percent were within the age below 15 years old.

The Table also reveals that 4.1 percent of the respondents fell within the age bracket of 21-25 years.

Age group of 26-30 years was 71.6 percent while 20.8 percent of the respondents were found to be of 30 years and above.

This implies that youths of the age range of 26-30 years form bulk of the respondents with the mean age and the standard deviation of  $17.8 \pm 0.91$  years of age.

This finding is in agreement with that of [5] which defined youth as a group of people that are found within the age group of 13-30 years of age.

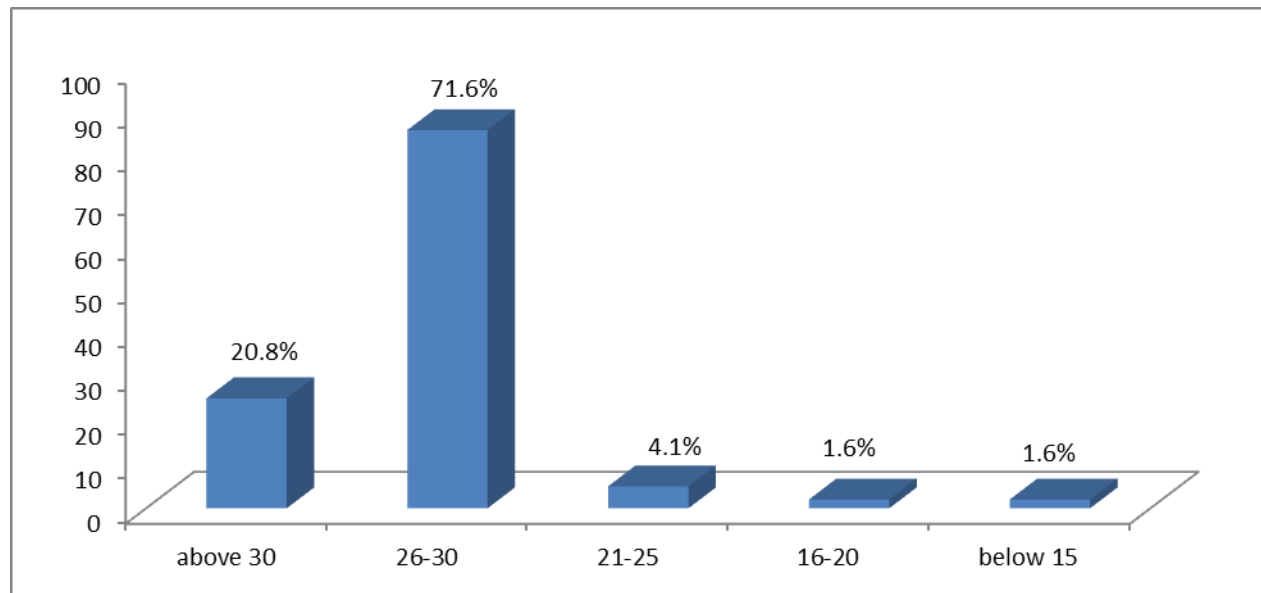

Fig.1.Distribution of respondents based on age group  
Source: Field Survey, 2012

Also, results in Table 1 reveal that majority (55.8%) of the respondents were male, while 44.2 percent were female. This indicates that male respondents were slightly higher than female. This could be due to the fact that most parents in the rural areas invested more in male education than their female counterpart

based on [3] findings. More so, about 95.8 percent of the respondents were single, while only 4.2 percent of the respondents were married, indicating that majority (95.8%) of the respondents were not married, thus, still living with their parents.

Table 1. Frequency distribution of Personal and Socio-economic Characteristics of respondent

Variables	Frequency	Percentage	Mean	St. Dev.
<b>Age</b>				
10-15	25	20.8	17.8	3.6
16-20	86	71.8		
21-25	5	4.2		
26-30	2	1.6		
Above 30	2	1.6		
<b>Sex</b>				
Male	67	55.8		
Female	53	44.2		
<b>Marital Status</b>				
Single	115	95.8		
Married	5	4.2		
Divorced				
<b>Average stipend per month</b>				
Below ₦2000	56	46.7		
₦2000 - ₦4000	22	18.3		
₦4100 - ₦6000	6	5.0		
₦6100 - ₦8000	3	2.5		
₦9000 and above	7	5.8		
No response	26	21.7		

Source: Field Survey, 2012

Figure 2 shows that 54.2 percent were Muslims, 45.0 percent were Christians while very few (0.8%) of the respondents practiced traditional religion.

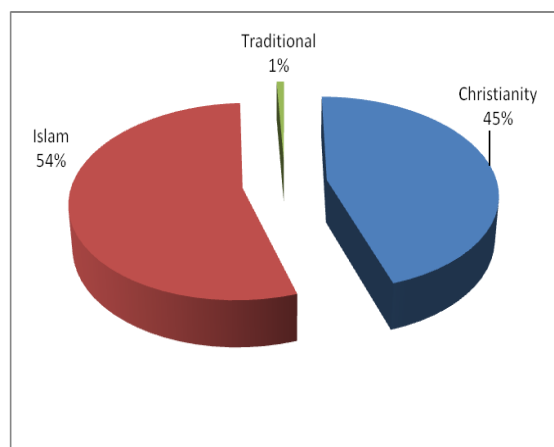

Fig.2. Distribution of respondents based on religion

Source: Field Survey, 2012

This indicates that Islam is the dominant religion in these areas. Furthermore, results in Table 1 show that about 46.7 percent of the respondents earned less than ₦2000 per month, 18.3 percent indicated ₦2000-₦4000 as their monthly stipends while 21.7 percent of the respondents did not indicate their month stipends. Also, the Table further reveals that 5.0 percent of the respondents earned between ₦4100 and ₦6000 per month

while 2.5 percent and 5.8 percent earned between ₦6100 and ₦8000 and ₦9000 and above as their monthly stipends, respectively. These analyses indicated that most of the respondents were not salary earners as most of them still depend on their parents for provision of their needs. This may serve as an hinderance to the aquisition of ICTs equipment by this category of people in the rural area. Results in Table 1 indicated that majority (58.3%) of the youth were computer literate. This implies that their knowledge of ICTs use may be high.

**Awareness of ICTS tools and level of awareness**

Results in Figure 3 show that 56.0 percent of the respondents were aware of the use of telephone in disseminating information to the farmers, 53.0 percent were aware that radio could be used to disseminate agricultural information to the farmers, 41.7 percent indicated that they were aware of the use of television to disseminate information to the farmers. Also, 35.0 percent and 30.0 percent indicated that they were aware of using internet and print media to pass agricultural information to the farmers. An indepth analysis using mean and standard deviation to rate the youth level of awareness of ICTs use

showed that 71.7 percent of the respondents were rated high in ICTs awareness in farming, 17.1 percent rated low while 11.2 percent of the youth were rated moderate in awareness score as shown in Figure 4. This implies that youth in the study area were rated high in their level of awareness of ICTs use in farming.

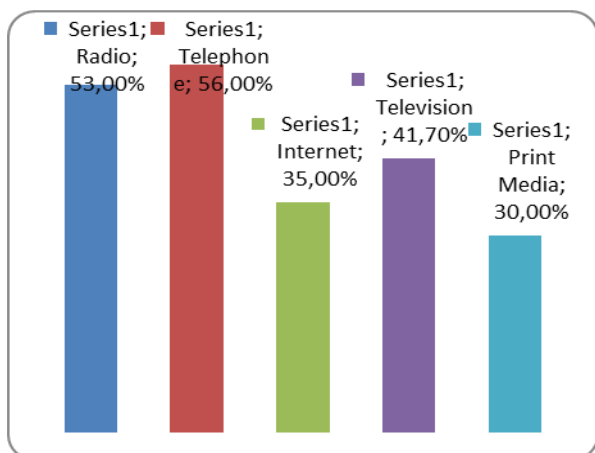

Fig.3. Distribution of youth based on their awareness on the use of ICT in farming  
Multiple responses

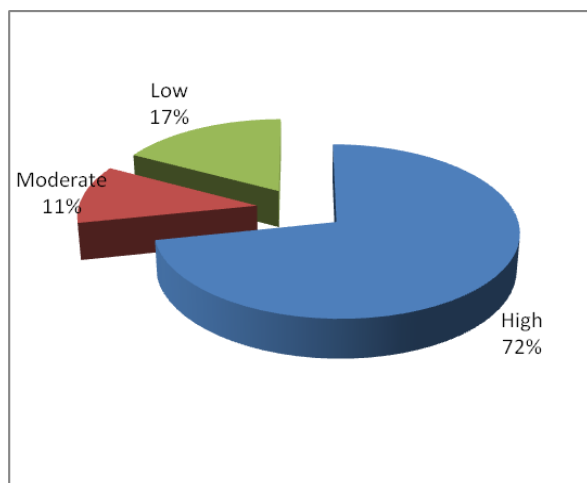

Fig.4. Respondents' rating in ICTs awareness score  
Source: Field survey, 2012

### Access to ICTs tools

Results in Table 2 show that 39.2 per cent of the youth had access to television, 37.5 per cent had access to telephone set while 10.0 per cent and 7.5 percent had access to radio and computer, respectively.

This reveals that majority of the respondents had access to television. This means that television is the most accessible ICTs equipment to many youth as a medium of

passing agricultural information to the farmers in the study area.

Table 2. Accessibility of the respondents to ICTs tools

Selected ICTs tools	Frequency	Percentage
Television	47	39.2
Telephone set	45	37.5
Radio	12	10.0
Computer	9	7.5
Others	7	5.8

Source: Field survey, 2012

### Perception of youths to ICTs use in agricultural information dissemination

Results in Table 3 show that a larger percentage of the respondents disagreed with the notion that ICTs has nothing to do with agriculture, 32.5 percent disagreed to this statement, 8.3 percent strongly agreed to the statement. Also, a very large percentage (43.3%) strongly disagreed that evil spirits are used in the production of ICTs tools. This implies that most of the respondents perceived ICTs as something that could be used to improve agricultural productivity in the study area.

32.5 percent of the respondents strongly disagree that only the rich can use ICTs tools while 15.8 percent strongly agree to the statement. This implies that most of the respondents perceived ICTs as tools that could be used by both the rich and the poor provided they have adequate knowledge of it. 27.5 percent of the respondents disagree with the notion that people using these facilities were cheats or trickers. It implies that most of the youths know the use and importance of internet facilities. Likewise higher proportions (36.7%) strongly agree that television and internet exposes one to social vices. 34.2 percent of the respondents picked strongly agree to the the statement. Few (12.5%) strongly disagree with the statement. 39.2 percent agreed that ICTs tools play an important part in eroding our culture and affecting our ways of doing things while 6.7 percent disagreed. This reveals that the respondents know the adverse effect ICTs has had on the society with special focus on agricultural productivity.

Table 3. Youth perception of ICTs tools usage in agricultural information dissemination

		SA	A	U	D	SD
ICTs has nothing to do with Agriculture	Freq.	10	23	18	39	30
	%	8.3	19.4	15	32.5	25
Evil spirit are used in the agricultural production	Freq.	15	15	15	23	52
	%	12.5	12.5	12.5	19.2	43.3
Only the rich use the phones and internet facilities	Freq.	19	13	10	39	39
	%	15.8	10.8	8.3	32.5	32.5
People who use internet facilities are trickers	Freq.	10	31	28	33	18
	%	8.3	25.8	23.3	27.5	15
Television and internet exposes one to social vices	Freq.	41	44	15	15	15
	%	34.2	36.7	12.5	12.5	12.5
ICTs tools play important part in eroding our culture and the way of doing things	Freq.	33	47	12	20	8
	%	27.5	39.2	10	16.7	6.7
ICTs tools provide exposure of the youth and effect changes in every communities	Freq.	42	58	15	4	5
	%	35	48.3	12.5	3.3	4.2
ICTs tools make access to information easier	Freq.	69	38	7	1	18
	%	57.5	31.7	5.8	0.8	15

Source: Field survey, 2012

In addition, 48.3 percent of the respondents agree that ICTs tools provide exposure for the youth and also effect changes in every communities. 35 percent strongly agree, 12.5 percent were undecided while 0.8 percent disagree. 57.5 strongly agree that ICTs tools make access to information easier for people, while 4.2 percent disagree to the statement.

It can be deduced from the results that 27.5 percent of the total respondents strongly disagree that ICTs tools are majorly for entertainment while 10 percent and 15 percent are undecided and strongly disagreed with the notion.

**Relationship between youth awareness and their perception in the use of ICTs tools in disseminating agricultural information**

Results in Table 4 showed that positive ( $r = 0.481$ ;  $P \leq 0.05$ ) significant relationship existed between youth awareness of ICTs and their attitude towards the use in disseminating agricultural information at 5% level of significance.

This implies that the higher the awareness rate, the more positive their attitude towards the use.

This conforms with the expectation of the study that awareness could make one to develop favourable attitude towards the use of certain equipment, techniques or methods in all sphere of life.

The contribution of awareness to the attitude of the respondents was 23.1 percent.

Table 4. Results of Pearson Correlation analysis showing the relationship between awareness of ICTs and their perception towards the use in disseminating agricultural information

Variable	Pearson's correlation	Coefficient determination	of Decision
Total awareness score	0.481**	0.231	S

Source: Field survey, 2012.

\*Significance at 0.01 (1%) level

\*\*Significance at 0.05 (5%) level

**CONCLUSIONS**

The use of ICTs in farming could bring about high productivity if the youths and other agricultural development stakeholders perceive ICTs tools as media of agricultural transformation. Furthermore, in order to enhance paradigm shift in the agricultural practices among our farmers to forestall food insecurity, youth training and retraining in the use of ICTs is highly essential. This will promote adequate and timely information sharing among the farm families and the consumers with a view to promoting agricultural productivities for food security in Nigeria.

Based on the findings, the study concludes that majority of youths were rated high in their level of awareness of ICTs tools in agricultural information dissemination and telephone and radio were the major ICTs tools used in agricultural information

dessemination. The study concludes that awareness of ICTs influenced their perception towards the use of ICTs. The study recommends that youths should be more involved in the use of ICTs in disseminating agricultural information with a view to improving agricultural productivity in Osun State.

## REFERENCES

- [1]Adedoyin, S. F., 2003, The Nigerian Child and the National, plan for decent livelihood in the Annual Research Network Meeting and Conference of Children –in Agriculture Programme (CIAP) Lagos Nigeria pp 1-8.
- [2]Aina, L. O., 1989, Education and Training of Librarian for Agricultural Information work in African. Quarter Bull. IAALD.34(1), 23-26
- [3]Deji, O.F., 2011, Gender and rural development. Berlin series on Society, economy and politics in developing countries Vol 106.
- [4]Torimiro, D.O, Kolawole, D.O., Okorie, V.O., 2007, In-school farm youth and ICT usage: A gender analysis of Nigeria's Yoruba communities. Journal of youth studie, Vol 2, (1)
- [5]Torimiro, D. O., 1999, Factors Associated with Youth Participation in Rural Leadership Development Activities in Ogun State, Nigeria). An unpublished Ph.D.Thesis. Department of Agricultural Extension and Rural Department, Obafemi Awolowo University, Ile-Ife, Osun State. Pp. 11- 46.
- [6]Torimiro, O. D., Yomi, A., 2008, Communication in Agricultural Extension. In Akinyemiju, O. A. and Torimiro, O. D. (2008) Agricultural Extension: A comprehensive Treatise with Model of Questions and Glossary. ABC Agricultural System Ltd, 99A, Obafemi Awolowo Way, Ikeja, Lagos, Nigeria. Pp. 134.
- [7]Olowu, T. A., Oyedokun, A. O., 2000, Farmers' Accessibility of Agricultural Marketing Information: The Case of Oyinladun Radio Programme. J. Econs. And
- [8]Van den Ban A.W., Hawkins, H. S., 1992, Agricultural Extension, Blackwell Science, Oxford. pp. 19-23.
- [9]Youdewei, A., 1995, The Role of Information for Rural Development in ACP Countries. Proceedings of an International Seminar, Montpellier, France, pp. 12-16.
- [10]World Bank, 2007, "Executive summary" in World Bank. Rural Development: From Vision to action, the next generation, World Bank, Washington, D. C.





## TECHNICAL CONCEPTION OF FARMERS TO ECONOMIC POSSIBILITY OF EXPANDING OILSEED RAPE CULTIVATION IN NORTH-EAST OF IRAN

Mehdi AZIZI, Mohammad MAZHARI, Abbas FALLAH TOOSI

Khorasan Razavi Agriculture & Natural Resources Research Center, SPII Department, Social-Economic Dept. POBox: 91735-488, Mashhad, Iran, Phone: +98513.340.9138, +98915.315.0412, Fax: + 98513.382.2390, Emails: meh\_azizi2003@yahoo.com, afallahtoosi@gmail.com, mohammad\_mazhari@yahoo.com

*Corresponding author:* meh\_azizi2003@yahoo.com

### Abstract

*Winter rapeseed is relatively new introduced crop that is in competition with winter cereals especially irrigated wheat in North-east of Iran. Farmers must to decide which of them is more economic and profitable for cultivation. Local farmers have a good technical cognition about wheat cultivation historically, so this crop has more chance for selecting in their cropping system compared to rapeseed. Besides, lack of technical recognition about rapeseed cultivation and management is led to lower seed yield compared to wheat. This research was conducted for determining the competitiveness capability of rapeseed and its some technical and economical aspects in that region. Results showed, almost the half of statistical community of farmers were satisfied for rapeseed cultivation. They were who had been achieved more than 1800 Kg.ha<sup>-1</sup>, seed yield. For increasing rapeseed economic yield in farmer's fields, it needs to promote their technical knowledge about crop management too. Relative to this fact, 66.7% of farmers believed, rapeseed in cropping system could be reduce weeds and increase the yield of subsequent crop. 70% of farmers believed that oilseed rape- cereals rotation can increase the wheat seed yield after rapeseed. Eless of these beliefs, still 48% of farmers has a weak conception to expanding oilseed rape cultivation areas.*

**Key words:** rapeseed-wheat rotation, cropping priority, farmer's viewpoint, farmer's interest, profitable crop

### INTRODUCTION

Iran is spending a large amount of foreign exchange for import of edible oil, because more than 90% of country's edible oil is imported. For solving this problem, the government of Iran has focused on new and high potential oilseed crops.

Rapeseed is almost new oilseed crop that has entered to Iran's cropping system about two decades. In north-east of Iran one of the greatest worries of farmers is economic competitiveness and selecting between rapeseed and cereals for winter cultivation (Azizi and Moayedi, 2012) [1].

Sedighi (2002) has confirmed on the positive relationship between farmer's technical knowledge and their viewpoint to planting rapeseed. [5].

Yazdani (2007) based on a questionnaire survey, concluded that about 50 percent of his sampling population had no interest to cultivation of rapeseed for the second time. [7].

These group were who had not enough cognition against the crop and its agronomic management.

Economic yield of rapeseed in north-east of Iran must be increased gradually until it be economically profitable compared to wheat (Azizi and Moayedi, 2012) [1].

Technology transfer, training and agricultural extension education are key factors for adopting a new crop in a new region.

These empower and help farmers to better decision (Blackburn and Flaherty,1994; Rogers,1995; Tiraieyari et al.,2010) [2, 3, 6].

The average rapeseed yield in Iran is comparatively low, and there is a gap between the potential and realized yield representing the potential of technology and training for improving the economic yield and farmer's interests.

This paper concludes the competitiveness capability of oilseed rape and its some technical and economical aspects in north-east of Iran.

**MATERIALS AND METHODS**

Quchan area in north-east of Iran was considered to perform this experiment. Farms underlying this research were distributed in a area about 3,500 hectare. The method of study was “survey research” with 300 rapeseed farmers sampling community. This research was done on 2009-2010. We used questionnaire for collecting data. The questionnaire was included questions about agro-technical factors, satisfaction, costs and incomes, and governmental support from rapeseed farmers.

Common biometric methods was applied for data analysis., such as, determination of relative frequency, cumulative frequency distribution, Pearson’s normal distribution and correlation analysis( Sanders, 1990).

**RESULTS AND DISCUSSIONS**

Farmer’s viewpoint about the effect of existing rapeseed in their crop rotation as a preceding crop before wheat has shown in table 1. Table consists of some agro-technical variables that are important in agricultural management. Based on farmers standpoints yield increasing of subsequent crop specially wheat in this case, and weed cleaning the field after rapeseed, are two advantages of planting this crop in rotation. Unpublished data also showed the water consumption per hectare of rapeseed fields was less than same area as wheat crop, 53% farmers believed.

Table 1. Effect of entering rapeseed to crop rotation of the region.

Variables	Frequency	Percent	Cumulative percent	P-Value	t
Yield of subsequent crop	100	33.3	33.3	0.22	-1.254 <sub>ns</sub>
Reducing of weeds	100	33.3	66.7		
Soil fertility	70	23.3	90		
Reducing of pests and diseases	30	10	100		

Ns: non significant statistically.

Table 2, is about production costs. 23.3% of farmers were believed the costs for rapeseed production is lower than wheat but 70% of them evaluated that are equal. Based on t

value ( $p \leq 0.01$ ) the option of “ equal” in questionnaire was statistically significant in this survey.

Table 2. The cost of planting one hectare rapeseed compared to wheat

Options	Frequency	Percent	P-Value	t
More	20	6.7	0.01	5.819 <sub>**</sub>
Equal	210	70		
Lower	70	23.3		

\*\*significant statistically.

So we focused on table 3, i.e. the income’s viewpoint of farmers about planting rapeseed compared to wheat.

Table 3. The income of planting one hectare rapeseed compared to wheat

Options	Frequency	Percent	P-Value	t
More	180	60	0.01	5.654 <sub>**</sub>
Equal	110	36.7		
Lower	10	3.3		

\*\*significant statistically.

As a result, the income obtained from rapeseed field’s unit in uniform conditions was more than wheat’ field in that area, 60% farmers believed. They were who had been achieved more than 1,800 Kg.ha<sup>-1</sup> seed yield. t value ( $p \leq 0.01$ ) shows, this option is statistically important. Also another field survey showed a suitable and satisfactory economic yield for rapeseed can be competitive with wheat is about 1800-2000 Kg.ha<sup>-1</sup> (Azizi and Moayedi, 2012) [1]. Another success factor for rapeseed planting in Quchan is selecting proper sowing date because this area is a very cold region in north-east of Iran (Yazdani, 2007) [7].

Table 4. The farmer’s viewpoints about governmental support for planting rapeseed.

Options	Frequency	Percent	Cumulative percent	P-Value	t
Very low	40	13.3	13.3	0.056	1.992 <sub>ns</sub>
Low	50	16.7	30		
Average	120	40	70		
Appropriate	90	30	100		

Table 4, shows the farmer’s viewpoints about governmental support for planting rapeseed. Only 30% of farmers believed that, the support of government was appropriate and 40% rated it as average.

## CONCLUSIONS

Anyway, it is a fact that, with entering a new crop to a agricultural system we need to prerequisites such as technical support, agronomic and professional training, extensional programs, etc., for success.

In This research 66.7% of farmers believed, oilseed rape in cropping system could be reduce weeds and increase the yield of subsequent crop. 70% of farmers believed that oilseed rape- cereals rotation can increase the wheat seed yield after rapeseed. Eless of these beliefs, still 48% of farmers has a weak conception to expanding oilseed rape cultivation areas.

## ACKNOWLEDGEMENTS

This research work was carried out with the support of Khorasan Razavi Agriculture and Natural Resources Research Center, Seed and Plant Improvement Institute, Mashhad, Iran.

## REFERENCES

- [1]Azizi, M., Moayedi, A.A.,2012, Effect of extensive educational resources in farmer's conception change for rapeseed cultivation. *Procedia- Social and Behavioral Sciences* 46: 2519-2522.
- [2]Blackburn, D.J., Flaherty, J.,1994, Historical roots. *In* D.J.,Blackburn (Ed.) *Extension handbook: process and practices* pp:1-7. Toronto. Thompson Educational Publishing Inc.
- [3]Rogers, E. M.,1995, *Diffusion of innovations*. 4th edition. Free Press.
- [4]Sanders, D.H., 1990, *Statistics: A fresh approach*. Fourth edition . McGraw-Hill Pub.
- [5]Sedighi, H., 2002, Factors affecting on viewpoint of farmers to developing oilseed rape cultivation in Arak. *Agricultural Economic and Development* 52: 133-145.
- [6]Tiraieyari, N., Idris, K., Uli, J., Azimi, H., 2010, Importance of program development competencies for agricultural extension agent's performance in process of technology transfer. *American Journal of Agricultural and Biological Sciences*. 5 (3): 376-379.
- [7]Yazdani, M., 2007, *Technical and economic comparison between wheat and oilseed rape crops in Quchan region, A case study*. MSc. Thesis, Islamic Azad University of Bodjnord., Iran.



## THE EVALUATION OF CHOLESTEROL CONCENTRATION IN EGG YOLKS CONTAINING OXYTETRACYCLINE RESIDUE

Silviu Ionut BEIA<sup>1</sup>, Ioan Iulian ALECU<sup>1</sup>, Violeta Elena BEIA<sup>2</sup>

<sup>1</sup>University of Agricultural Sciences and Veterinary Medicine Bucharest, 59 Marasti, District 1, 11464, Bucharest, Romania, Phone/Fax: 0040723468301, Email: beiaionut@yahoo.com, Phone: 0040723970059, Email: iulian\_alecu\_2000@yahoo.com

<sup>2</sup>National Sanitary Veterinary Authority for Food Safety, 1, Presei Libere Square, Building D1, District 1, Zip code 013701, Phone: 0040766335246, Email: beia.violeta@ansvsa.ro

**Corresponding author:** beiaionut@yahoo.com

### Abstract

*The purpose of this paper is to calculate the percent of cholesterol and the triacylglycerols which are very important for the pharmaceutical, cosmetic and aquaculture products. We have chosen the cholesterol thanks to its important share from the lipid overall in the egg yolk, considering that this compound might be the marker of chemical denaturation, induced by the medicinal residue over the nourishing components in the egg. We considered that it is important to the correlation between the level of oxytetracycline and the level of cholesterol in the yolk in the case on administration through drinking water and after intramuscular administration. The concentration of cholesterol in the yolk is not a direct consequence of the presence of antibiotics in the egg. The medium value of the cholesterol in eggs coming from hens under treatment, differs based on how the antibiotic is being administered, being larger in the case of the hens who received the antibiotic through drinking water (5.9g cholesterol/100 g yolk), than the ones who have been treated through intramuscular administration (5.5 g cholesterol/ 100 g yolk); a resembling situation can be observed in the case on cholesterol values, measured after ending the oxytetracycline treatment.*

**Key words:** administration, cholesterol, oxytetracycline, residue, triacylglycerols

### INTRODUCTION

The cholesterol is an important component of egg yolk, representing 1,6% of its mass and 5% of its fat [6].

The free cholesterol represents 84% of all cholesterol, the remaining 16% being represented by cholesterol esters [5]. As a forerunner of the bile acids, sexual hormones and adrenal hormones, the cholesterol plays an important role in the well-functioning of cells as well as in the metabolism of lipoproteins. As recognition of its special properties, the attempts of selectively extracting the cholesterol and fatty acids from the yolk without deteriorating the proteins and phospholipids can be mentioned. In order to extend the investigations concerning the effects of oxytetracycline residue on the chemical composition of the egg, an attempt of evaluation of cholesterol concentration in egg yolks containing oxytetracycline residue was considered well-timed.

### MATERIALS AND METHODS

For this study, 3 eggs were used for each day of analysis and for each individual group of hens. In order to obtain some information about associating the oxytetracycline treatment with the chemical pollution of the internal environment of the egg, a batch of egg hatching hens, weighting the same and having similar maintenance and health state, was used. The batch was formed of 20 egg hatching hens, which were submitted to the analysis regarding this study, after dividing them into two groups. The oxytetracycline administration was performed differently for each one of the two groups, as following:

Group 1 – intramuscular administration;

Group 2 – oral administration, through drinking water.

The study was based on experimental, intramuscular administration of oxytetracycline, under the form of the commercial product Egocin 10% L.A. (1 ml injectable solution contains 200 mg

oxytetracycline dehydrate), to the 10 hens in the first group, at a dosage of 2 ml/kg, each day, for five days.

In the second group, the oxytetracycline hydrochloride was given through drinking water during a week, at a dosage of 2 g/liter of water. The eggs were collected twice a day (in the morning and in the evening), during the treatment and also after the final administration, until residue could not be detected anymore. Since the monitoring was realized within 20 days for both groups of hens included in the experiment (7 days of treatment + 13 days of post-treatment, in case of administration through water; 5 days of treatment + 15 days of post-treatment, in case of intramuscular administration). The determination of oxytetracycline residue levels was performed using the high pressure liquid chromatographic with post column derivatization and fluorescence detection technique. Hereby, in the case of the intramuscular treated hens, the last two days of treatment were chosen (4 and 5), corresponding to values of residual antibiotic of 3.63 µg/g and 4.21 µg/g, as well as days 3 and 4, after the final administration, corresponding to values of 9.53 µg/g and 5.43 µg/g. In the case of the orally treated hens, there were chosen for sampling, the last two days of treatment (6 and 7), corresponding to values of 2.87 µg/g and 2.96 µg/g, as well as the first two days after the final administration, corresponding to values of 3.30 µg/g and 1.67 µg/g (µg oxytetracycline/g yolk). Thanks to the fact that the determinations were achieved within 4 days for each group of hens (corresponding to different types of administration of the antibiotic), using 3 eggs for each group and for each day of control, 12 eggs were analyzed for each group, totaling 24 eggs necessary to the study. The method used for extracting the cholesterol implies a working protocol based on the next steps:

A quantity of 0.5 ml of yolk, along 20 ml of methanolic potassium hydroxide and 10 ml of isopropanol, are kept on a water-bath, with refrigerator, for about 30 minutes.

After cooling, the mix is completed with isopropanol, until reaching 50 ml.

The filtering of the homogenized is realized.

The clear obtained filtered is used for the enzyme dosage of the cholesterol.

The principle of the dosing method:

The cholesterol is oxidized by the cholesterol oxidase into cholesteron. In the presence of catalase, the resulted hydrogen peroxide from this reaction, oxidizes the methanol into formic aldehyde [2]. The formic aldehyde reacts with the acetyl-acetone, a substance which produces, in the presence of ammonium ions, the color yellow. The concentration of the colored compound is directly proportional with the concentration of the cholesterol and with the intensity of the color, evaluated at a wave length of 405 nm [1]. The reactions involved in the chemical transformations described above are the following:

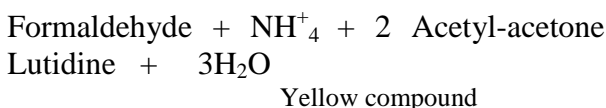
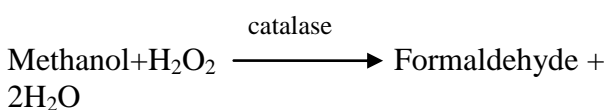
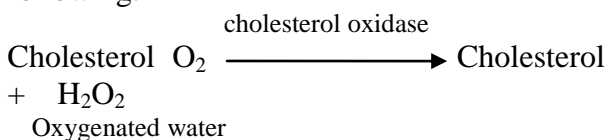

The working technique and the calculus of the results were realized according to the usage recommendations of the kit promoted at the Boehringer-Munheim firm, and the concentration was expressed in g cholesterol/100g yolk probe.

## RESULTS AND DISCUSSIONS

The evaluations of the lipid content of the yolk, amongst other biochemical compounds, can provide information about what the presence of antibiotic residue doe the biochemical composition of the egg. The obtained results (Table 1) show that high concentrations of antibiotics (oxytetracycline) in the yolk (9.53 maximum oxytetracycline concentration (9.53 µg/g) cause dropping of the cholesterol concentration (4.90 g/100g). An important aspect is represented by the fact

that the concentration of the antibiotic (4.21 µg/g), as well as the dropping of the level of cholesterol (5.20 g/100g), are significantly modified when the medicine is injected.

Table 1. The correlation between the level of cholesterol in the yolk and the concentration of oxytetracycline, in the case of intramuscular administration (medium values).

	Time (days)	Concentration of OTC <sup>(3)</sup> µg/g	Concentration of cholesterol g/100g
During the treatment <sup>(1)</sup>	4	3.63	5.80
	5	4.21	5.20
After the treatment <sup>(2)</sup>	3	9.53	4.90
	4	5.42	5.05

Source: Own calculations

1 – numbering from the beginning of the treatment

2 – numbering from the final administration

3 – Oxytetracycline

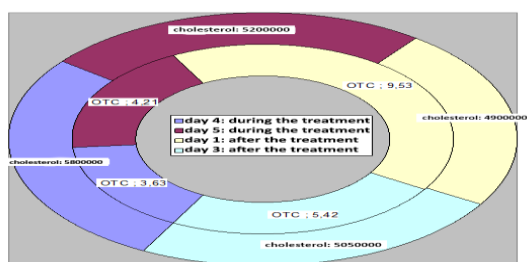

Fig.1. The connection between the level of oxytetracycline and the level of cholesterol in the yolk, in the case of intramuscular administration

Source: Own calculations

The reverse proportionality between the concentrations of oxytetracycline and the level of cholesterol from the yolk shows evidently from the graphic representation in the table 1, as well as the figure 1, state the fact that the minimum value of cholesterol (4.90 g/100g), was determined in the probes with the maximum oxytetracycline concentration (9.53).

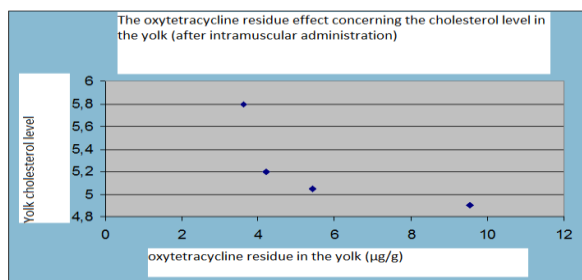

Fig.2. The oxytetracycline residue effect concerning the cholesterol level in the yolk (after intramuscular administration)

Source: Own calculations

The oral administration of the medicine, unlike the intramuscular one, didn't cause large variations concerning the cholesterol content of the eggs gathered during the days in which the elimination of the antibiotic through the yolk was at its maximum 3,30 µg/g, the values being shown in the figure 2. The results, presented highlight a relatively constant concentration of this biochemical compound in the egg yolk, derived from oxytetracycline treated hens, the oxytetracycline being administered through drinking water. As well as shown in the Table 2, in the six day the concentration of OTC was 2,87 µg/g and the concentration of cholesterol was 5, 90 g/100g.

Table 2. The correlation between the level of cholesterol in the yolk and the concentration of oxytetracycline in the case on administration through drinking water (medium values)

	Time (days)	Concentration of OTC <sup>(3)</sup> µg/g	Concentration of cholesterol g/100g
During the treatment <sup>(1)</sup>	6	2.87	5.90
	7	2.96	5.91
After the treatment <sup>(2)</sup>	1	3.30	5.82
	2	1.67	6.01

Source: Own calculations

1 – numbered from the beginning of the treatment

2 – numbered from the last administration

3 –oxytetracycline

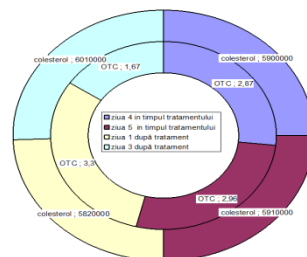

Fig.3. The correlation between the level of oxytetracycline and the level of cholesterol in the yolk in the case on administration through drinking water

Source: Own calculations

These results suggest the fact that there is a correlation between the lipid metabolism of the antibiotic treated birds and its level in the egg. The obtained results are in conformity with data from the literature [7] which notice a drop of the concentration of the serum

cholesterol, following the injectable oxytetracycline treatment.

Table 3. The effect of oxytetracycline residues on the cholesterol level in the yolk (after oral administration).

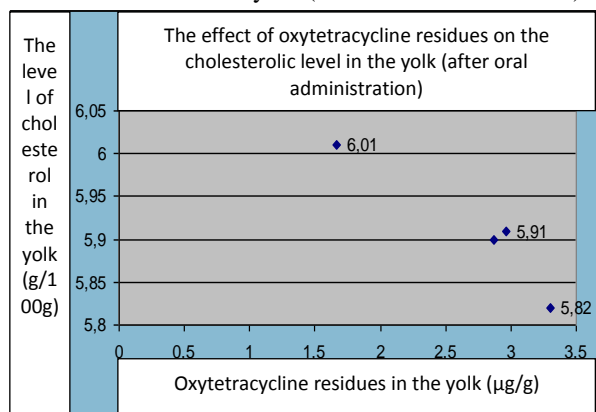

Source: Own calculations

The same results were obtained by other researchers [4], who, after the injectable oxytetracycline treatment aiming a group of hens, he noticed the reduction of cholesterol and triglycerides in the yolk of the analyzed eggs, without recording any effect on the phospholipidic content.

## CONCLUSIONS

The drop of the concentration of cholesterol in the yolk is not a direct consequence of the presence of antibiotics in the egg, but of the effects that these have on the bird's organism, the low level of cholesterol in the eggs being correlated with a decreased cholesterolemia.

The investigation of egg yolks from the birds who had taken the antibiotic through drinking water, mark out the fact that the concentration of the antibiotic, as well as the drop of the cholesterol's concentration, are much less important.

The medium value of the cholesterol in eggs coming from hens under treatment, differs based on how the antibiotic is being administered, being larger in the case of the hens who received the antibiotic through drinking water (5.9g cholesterol/100 g yolk),

than the ones who have been treated through intramuscular administration (5.5 g cholesterol/ 100 g yolk); a resembling situation can be observed in the case on cholesterol values, measured after ending the oxytetracycline treatment.

## ACKNOWLEDGEMENTS

The paper was elaborated during the postdoctoral stage organised by „Postdoctoral School of Zootechnical Biodiversity and Food Biotechnology”, Contract POSDRU 89/1.5/5/63258.

## REFERENCES

- [1]Awade, A.C., Moreau, S., Molle, D., Brule, G. and Maubois J.L., 1994, Two-step chromatographic procedure for the purification of hen egg white ovomucin, lysozyme, ovotransferrin and ovalbumin and characterization of purified proteins. *Journal of Chromatography A* 677(2):279-288.
- [2]Bade, H., Stegemann, H., 1984, Rapid method of extraction of antibodies from hen egg yolk. *Journal of Immunological Methods* 72(2):421-426
- [3]Balevi, T., Coskun, B., 2004, Effects of dietary copper on production and egg cholesterol content in laying hens. *Br Poult Sci.* 2004 Aug;45(4):530-4.
- [4]Bărzoi, D., Meica, S., Neagu, M., 1999, *Alimentaire Toxinfection*, Ed. Diacon Coresi, Bucureşti;
- [5]Beia Violeta, Pop Aneta, Savu, C., Beia, S.I., 2005, Concentration of slug, cadmium and copper in chicken eggs in suburban areas and the rural area, *Papers of Scientific Symposium U.S.A.M.V., Faculty of Veterinary Medicine – Bucharest.*
- [6]Beia Violeta, Savu, C., Beia, S.I., Florea, C., Beia Daniela, 2005, Study importance of microbiological determinations for eggs and egg products, *Scientific International Symposium „Results and perspectives in agriculture „Agrarian State University from Republic of Moldova, Chişinău.*
- [7]Shaddad, S.A., Wasfi, I.A., Maglad, M.A., Adam, S.E., 1985, The effect of oxytetracycline on growth and lipid metabolism in poultry. *Comp. Biochem. Physiol.*, 80C: 375-80.



## FOLIAR OR CHEMICAL FERTILIZERS FOR GARDEN PEAS

Ion BOZGA<sup>1</sup>, Olimpia PANDIA<sup>1</sup>, Ion SARACIN<sup>2</sup>, Ioan Christi GANEA<sup>3</sup>

University of Agricultural Sciences and Veterinary Medicine, Bucharest, Romania, Faculty of Management, Economic Engineering in Agriculture and Rural Development, Slatina Branch, 150, Strehareti Street, Zip Code 0500, Slatina City, Olt County, Romania,  
E-mails: [veterinar\\_serv@yahoo.com](mailto:veterinar_serv@yahoo.com); [olimpia\\_pandia@yahoo.com](mailto:olimpia_pandia@yahoo.com)

<sup>2</sup>University of Craiova, Faculty of Agriculture, 19, Libertatii, Craiova City, Romania, Phone: +40251418475, E-mail: [ion\\_saracin@yahoo.com](mailto:ion_saracin@yahoo.com)

<sup>3</sup>National Institute of Agriculture Mechanization, Bucharest, Romania, E-mail: [ganea007@yahoo.com](mailto:ganea007@yahoo.com)

**Corresponding author:** [veterinar\\_serv@yahoo.com](mailto:veterinar_serv@yahoo.com)

### Abstract

*The main objective of this paper was the research and controlled study of the main physiological processes of the garden pea, the type Redondo, with the purpose of knowing adaptability the natural conditions in the area. In this purpose, was observed the special behavior of the garden pea Redondo, at the meteorological conditions that exist in this study (temperature, moist, light intensity) determining physiological that took place: photosynthesis, chlorophyll, perspiration, absorption and index of the foliar surface. During the vegetation have been realized observations regarding: moment of arising, apparition of the first real leaves, dynamics of formation leaves and their dimensions, the number of plant leaves, formation of ramification of the roots, apparition of the floral buds, opening flowers, formation of fruits and reaching full maturity.*

### INTRODUCTION

Origin from Asia Minor and Central Asia, the pea (*Pisum sativum* L.) was cultivated in antiquity by Greek and Romans in the south of Europe, where afterwards was spread on the entire continent, and in our country was brought in the XVIIIth century.

The pea is cultivated on large surfaces for its seeds rich in protein (23-28%), carbon hydrates (46-50%), lecithin, vitamins (A, B1, B2, B3, B6 și C) and mineral salts of calcium, phosphor, potassium, zinc, magnesium, iron and manganese, etc. Pea consumption protects bone system, and vitamin K from this vegetable helps blood to clot, helps to establish the level of sugar in the blood, etc. These are used as food for human and as concentrate forage for animals.

The consumption of peas gives a source of high energy for the human body, being satiable. They do not fatten and are easy to procure and cultivate in the own garden. The peas is also known as a cure for treating diseases as abdominal cramps, is efficient in controlling anemia, fortifies the nerve cells,

controls fatigue and accelerates the cell regeneration.

### MATERIALS AND METHODS

The experience was positioned at the familial holding from Olt County, Grădinari Village, in 5 variants, according to the randomized blocks, positioned in 3 repetitions:

-Factor A- Type Redondo;

-Factor B- fertilized with Amofos (Russia), N25%, P<sub>2</sub>O<sub>5</sub> 60%; fertilized with Azomures NPK 25%, 25%, 25%;

-Factor C - fertilized with Synergizer 8-32-4 (foliar fertilization); fertilized with Kalpak (foliar fertilization).

For the identification of the properties or the key attributes of the soil, sensible to exchange the function of the soil will be the investigate research of a minimum set of indicators.

Indicators selected for evaluation of soil quality must show which are the present performances of the soil and how can be preserved and improved their functions for future usage. The selected indicators can refer to chemical characteristics or at processes that

took place at the level of the soil.

The planting was realized at 12.03.2013, in a soil with pH 6, 27, after in autumn was prepared by deep tillage (20 cm) and levelled for maintenance, and during spring was minced before plantation, and the soil temperature was of 3,8<sup>0</sup>C. The plantation depth was of 8 cm, and the distance between rows is of 14 cm.

Variants:

1. Witness;
2. Variant 2. Fertilized with Amofos, N25%, P<sub>2</sub>O<sub>5</sub> 60%
3. Variant 3 fertilized with Azomures, NPK 25%, 25%, 25%.;
4. Variant 4 fertilized with Synergizer 8-32-4 (foliar fertilization);
5. Variant 5 fertilized with Kelpak (foliar fertilization).

## RESULTS AND DISCUSSIONS

After the determination of the chemical characteristics in the soil from the area of study the following information has been obtained (graphic 1).

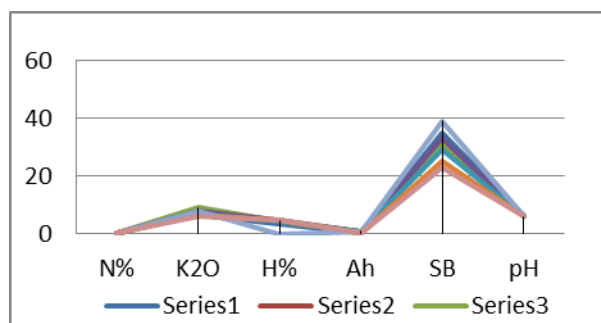

Fig. 1. Chemical characteristics of the experimented soil from the familial holding from Olt County, Grădinari Village

Source: Own determination.

The arisen took place at 27.03.2013, afterwards have been applied several protection works (weed) for extirpation of the herbs, when these were 8 cm height. The first real leaves appeared after 5 days and the administration of Amofos fertilization dressing for variant 2 and Azomures for variant 3.

During April month, took place the formation of the stem, of the vegetative mass and of the root that starts to be pivoting, with numerous

lateral ramifications on which will be found nodes. There will be realized treatments with foliar fertilizers (variant 4, fertilized with Synergizer 8-32-4 and variant 5 fertilized with Kelpak), [1].

Complex fertilizers give good results in the first vegetation phases, in comparison with the foliar ones, afterwards the application of the foliar ones begin to give better results.

Under the aspect of dynamics of increasing in height, we can observe that this assessed slowly at the beginning of the vegetation, especially at the foliar fertilized variants (16-29 April), and at 7th May, date that corresponds to a number of 38 days from planting, the plants reached a height of 42 cm, [3].

During the second intense growth that is developed during a period of 34 days, it was necessary the administration of a herbicide BASF Pulsar 40 1l / ha, being prevent the monocotyledonous and dicotyledonous.

The stems from variants 4 and 5 reached the height of 92 cm, and variant 2-3 at 82 cm. The number of interclass up to the first hull at variants 4-5 is of 9 and variants 2-3 is of 8.

The total number of interclass is at variants 4-5 of 19 and the 2-3 variants of 18.

The leaves are green and of ovoid form, the flower is white, their opening starting at the basis of the plant, the pollen was released from the opening of the flowers.



Photo 1. Pea plants reached in the period of inflorescence at all variants

Source: own results

At this type, the flowers opened between hours 10 and 18, remaining open for a period of 4 days. The blooming period is of 11 – 23 days, and the hull are a little curved, with lumpish edge of 9 and respective 10 cm, that

contain 7-9 beans, that are small, round, even and of green color, [2].



Photo 2. The first phenofase observations once with the administration of the fertilization dressing  
Source: own results

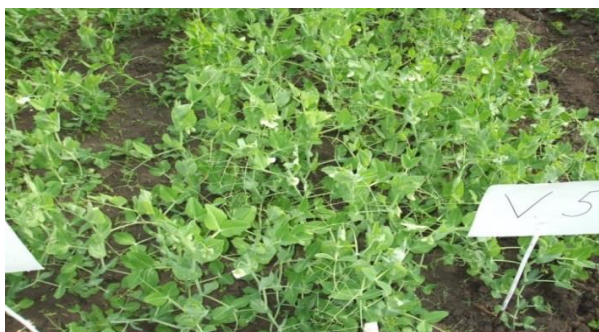

Photo 3. Variants of peas fertilized with Azomures and Amofos  
Source: own results



Photo 4. Variants of peas fertilized with Synergizer 8-32-4 and Kelpak  
Source: own results

A special particularity is that of the roots, for all variants, that developed up to a depth of 47 cm and the lateral roots exceeded 52-62 cm, being covered with nodosities. These nodosities have been spread more on the lateral roots of first order and towards the

basis of the root.

When 75% of the hulls reached full maturity (12th June), pea plants have been harvested. During this period have been obtained numerous information regarding the development of the vegetative mass during a period of 72 days for those 5 variants, this way:



Photo 5. Root when the plant was in the period of formation of blossom  
Source: own results

Table 1. The main phonologic information depending on used fertilizers

Nr. var	Seedin g	Rais ing mo ment	Fertilized	Mome nt of appari tion of first leaves	First interd ass	Total interd as	Date of the bloss om period	Avera ge length of the hull	Height of the plant
Var. 1	12.03.	27.03	witnes	08.04	11.04	13	19.04	4 cm	67/73 cm
Var. 2	12.03.	27.03	Amofos	06.04	08.04	18	16.04	8 cm	81 cm
Var. 3	12.03.	27.03	Azomures	04.04	07.04	18	15.04	8 cm	82cm
Var. 4	12.03.	27.03	Synergize r 8-32-4	07.04	09.04	19	14.04	9 cm	92 cm
Var. 5	12.03.	27.03	Kelpak	07.04	09.04	19	14.04	9 cm	93 cm

Source: own results



Photo 6. The chlorophyll physiological processes  
Source: own results

Firstly, as well in the second period, physiological estimations regarding the chlorophyll physiological processes were

carried out, the samples being taken from the pea leaves.

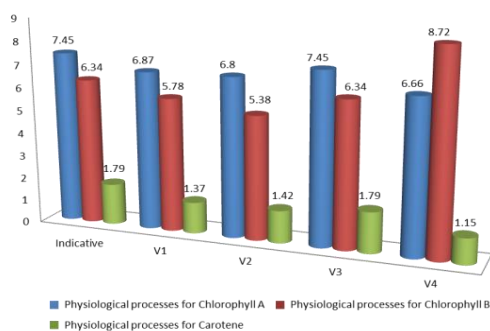

Fig.2. Determination of physiological processes pigments chlorophyll  
 Source: own results

Therefore, the results of the studied factors led to the conclusion that also the no irrigated pea, due to optimum temperatures and rain falling in this period, had a proper development, and the physiological processes that took place in the plant had good results in the control variant, but also in the plants treated with foliar fertilizers, especially with Kelpack and Azomures N25%; P 25%; K 25%.

## CONCLUSIONS

As a result of the phenophase determination, on the experimented soil is recommended the culture of early pea, as it gives better results up to apparition of high temperatures.

Seeding in a tillage that was correctly realized during autumn and at the depth of 20 cm, will realize increment in the production in comparison with the tillage realized during spring.

There are recommended early types, especially the ones planted in the first half of March.

Early forms of peas are accordingly to the droughty regions from the south and south – west of the country, when are cultivated in not wetted system.

The usage of the foliar is mentioned only after the first floors with interclass have been formed.

The type Redondo, s-was adapted to the

existent climate and soil conditions, is indicated to be taken into consideration for early spring cultures.

## REFERENCES

- [1]Pandia Olimpia, 2006, Research Regarding the Effect of Fertilizers upon Maize Production and Quality. Doctoral dissertation, Timișoara.
- [2]Pirsan, P., David, G., Imbrea, F., 2006. Phytotechny – cereals and legumes for grains. Eurobit Publishing, Timișoara.
- [3]Sărăcin Ion, 2008, Resesarch regarding the factors that influence the physico-chemical properties of the soil. Bulletin 1869 USAMV CLUJ NAPOCA, Vol 65(1)



## EU FUNDS FOR THE ROMANIAN AGRICULTURE DURING 2007-2013. STUDY CASE MEASURE 121- STATISTICAL DATA AND PRACTICAL IMPLICATIONS

**Aurelia Ioana BRÎNARU, Ion DONA**

University of Agricultural Sciences and Veterinary Medicine Bucharest, 59 Marasti, District 1, 11464, Bucharest, Romania, Phone: +40213182564, Fax:+40213182888, Emails: aurelia\_brinaru@yahoo.com, ion\_dona@yahoo.com

**Corresponding author:** aurelia\_brinaru@yahoo.com

### **Abstract:**

*The current paper envisages to present a section of the European funds in agriculture dedicated to Romania after 2007 (the EU accession) and its formal integration into the CAP system – with a particular accent on the Measure 121 and its impact at the end of 2014. Based upon raw data provided following an official request, it shows the main indicators of the system. It is also an analysis of the efficiency of EU funds utilization in the system. The paper focuses on the result received from the authorities with responsibilities in the area, thus bringing into the academic debate the first comprehensive data set for the time being that have become available to researcher. Following the analysis done we realise that Measure 121 had a major interest on behalf of the potential beneficiaries, as proven by the value of financing requests submitted in the analysed period that have surpassed 330% of the total allocated value. Another conclusion that surges is the great number of cancelled contracts in the last six months of the analysed period which represent 29,82% of the total of cancelled projects, a high percentage if we take into consideration that we are at the end of the implementation period of financed investments. Basing on this analyze, our study tries to draw some useful conclusion for the next financing period.*

**Key words:** absorption rate, cancelled contracts, European Agricultural funds, payments

### **INTRODUCTION**

The Common Agricultural Policy (CAP) is structured on two pillars: Pillar 1 that of the common market organizations and Pillar 2 that of rural development that presents the measures to be taken in regard with the development of rural areas. These measures are presented within the framework of the National Rural Development Programme, programme financed trough European Agricultural Fund for Rural Development (EAFRD). EAFRD was established in order to finance the Pillar 2 of CAP, in accordance with the provisions of the European Commission Regulation no 1290/2005.

The focus of the paper is going to be the impact of the program applied in Romanian after 2007 – more precisely a brief introduction of the programme and the importance of the Pillar 2- Rural Development given its percentage reflected trough the CAP allowance. Secondly I shall focus my attention on the implementation of the programme in the 2007 – 2013 financial

exercise. Thus the main topic of interest would be the Measure 121 and its impact. Measure 121 is a part of Axis 1- “Improving the competitiveness of agricultural and forestry sector“

The National Rural Development Programme 2007 – 2013 (NRDP) of Romania was approved in February 20, 2008 in Rural Development Committee meeting (Brussels) and signed by all 27 states. In March of 2008 were opened sessions submit the applications for the first three measures of the program – Measure 121 “Modernisation of agricultural holdings”, Measure 123 - Adding value to agricultural and forestry products” and Measure 322 - Village renewal and development, improvement of basic services for the economy and rural population and upgrading the rural heritage”.

A main source of information was represented by the official documents – the National Rural Development Programme 2007 – 2013, (versions 2007 – 2013), European Commission Regulations regarding CAP, Annual Progress Reports regarding the

implementation of the NRDP 2007 – 2013, other official sources.

## MATERIALS AND METHODS

The paper presents a comparative and qualitative analysis of the implementation of Measure 121 – Modernisation of agricultural holdings, related to the priority Axis 1 in Romania during 2008-2014. The first stage envisaged the analysis of the de facto situation at the end of 2014, analysis done through the consultation of the official published statistics (MARD), of progress reports regarding the implementation of NRDP 2007-2013, of selection reports regarding the financing requests, also through direct request toward Agency of Rural Investments Financing (ARIF) of the data related to the implementation of Measure 121 to the end of the year 2014. Following the gathering of the necessary information we have analysed and interpreted the data related to the implementation stage of Measure 121 at national level.

The main indicators used were: financing requests granted; national level signed contracts; payments done; cancelled contracts, number of finalized contracts, the annual average of the finalized projects during period 2011 – 2014, etc.

The main methods used in realising this analysis was the quantitative method of comparison in time (2008-2014), which can be applied by calculating the dynamic rhythm of the analysed phenomenon in the given time frame. Also we have analysed the payments effectively done each month and respectively on a yearly basis within the framework of Measure 121 in the analysed period and their interpretation on the basis of the results presented.

## RESULTS AND DISCUSSIONS

“At EU-27 level, within axis one, the measure "121 – Modernisation of agricultural holdings" shares 30.3% of the EAFRD, being the most relevant almost in every Member States. Romanian allocation to this measure range below to this average, which is quite

opposite to Latvia, Hungary and Lithuania approach, but similar to Spain, the Netherlands, Portugal, Slovenia, Finland approach. For Romanian programme, the most valued measure within this axis, is "123 – Adding value to agricultural and forestry products", followed by "121 – Modernisation of agricultural holdings", together sharing about half of axis resources.”[2]

Measure 121 is part of Axis I “Improving the competitiveness of the agricultural and forestry sector” which comprises three strategic priorities: human resources; competitiveness of the holdings; modernization of the processing and marketing sectors of agro-food and forestry products. The main objective of Measure 121 was to increase the competitiveness of the agricultural sector through a better utilization of human resources and production factors as well as the improvement of the quality of products obtained through respecting community norms regarding the eco-conditionality demands.[6]

Operational objectives aim to promote investments in vegetal and animal husbandry agricultural holdings, for new constructions and/or modernization of existing agricultural buildings and related utilities, machinery and new equipment procurement, plantations establishment etc. [4]

In accordance with the analyze of existing data at the end of 2014, in regards with the implementation at the national level of Measure 121 – Modernization of agricultural holdings, during 2008 – 2014 within the annual sessions 8.154 request for financing were submitted that were declared to be conformed with the requirements, through a verification process undertaken at the level of County Offices for Payments for Rural development and fishing [3] (Office for financing rural county currently- OFFRC).

In Table 1 we can notice that following the evaluation and selection process of Financing Requests, process undertaken within the framework of Evaluation, Selection and Contracting Unit, based on procedure manuals in force at the time of the evaluation of documentations a number of 3,375 Financing requests were selected in order to sign the

financing contracts, which means a total of 41,39% from all the Requests submitted.

Also at the end of the analysed period (March 2008 – December 2014) we can notice that the number of concluded contracts is of 2,642, while the number of cancelled contracts is of 560. The allowances utilization degree is calculated at the Agency of Rural Investments Financing (ARIF) level taking into consideration the allocation related to Measure 121 within the framework of NRDP 2007-2013 with the European Economic Recovery Plan (EERP) supplement, supplement of Euro 910.20 million.

Table 1. Accomplishment indicators related to Measure 121 “Modernisation of agricultural holdings” within the period 2008 – 2014, based upon the data provided by the Agency of Rural Investments Financing

Accomplishment indicators	No	Value mil. Euro)	Average value (mil. Euro)	Degree of utilization of allocations
Financing requests in accordance submitted	8,154	3,008.19	0.37	330.50%
Total Financing Requests submitted	3,375	1,250.13	0.37	137.35%
Financing requests selected through the Selection report	3,288	1,209.90	0.37	132.93%
Contracts concluded amended with those cancelled + value paid for cancellation 141	2,642	826.45	0.31	90.80%
Cancelled contracts	560	314.36	0.56	n/a

The Measure 121 proved to be, if we take into consideration only the number of finalized projects the great success story of the entire process and ever since 2009 we had a great number of projects that were finalized as the data provided by the Agency of Rural Investments Financing proved to us the high interest. Also the high number of cancelled contracts despite the high number of requests – shows the need for a professionalization of those who apply in order to write realistic projects as well as the high number of demands that a request must respect (extra bureaucracy) .

In accordance with Table 2, we had a very good start in 2009 with a total of 457 finalised projects, that represent 32.5% of the total of finalized projects within the period 2009 – 2014, the year 2009 being the first year when projects were finalized. The number of

finalised projects decline in 2010 to 393, that represent 27.9 % of the total of finalized projects, in 2011 to just 160 and in 2012 to 118 projects. In 2013 we had 130 projects and in 2014 around 149 projects. We tend to notice the decline of 2010 – 2011 a period marked by the economic crisis.

Table 2. The total number of projects and their value finalized trough Measure 121 “Modernisation of agricultural holdings” based upon the data provided by the Agency of Rural Investments Financing

Year	Number	%	Public contracted value (mil. euro)	%
2009	457	32.5	68.36	17.67
2010	393	27.9	99.50	25.72
2011	160	11.4	51.27	13.26
2012	118	8.4	58.61	15.15
2013	130	9.2	50.79	13.13
2014	149	10.6	58.27	15.07
Total	<b>1,407</b>	<b>100.0</b>	<b>386.81</b>	<b>100.00</b>

Analysing the situation of the projects finalized in the years 2011, respectively 2013 we realized that the value of finalized projects is very closed, Euro 51.27 million in the year 2011 that represent 13.26% of the total value of projects finalized within the period 2009 – 2014, and for the year 2013 a value of Euro 50.79 million respectively 13.13% of the total projects finalized in the same period.

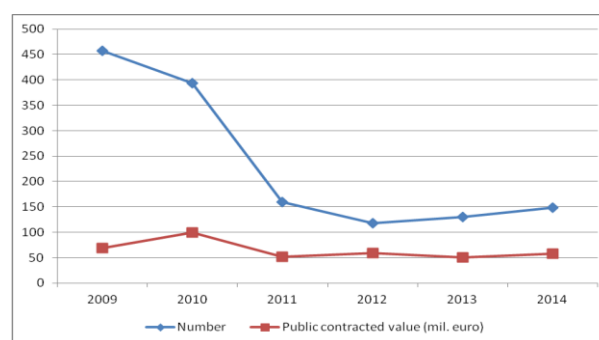

Fig.1. The total number of projects finalized trough Measure 121 “Modernisation of agricultural holdings” based upon the data provided by the Agency of Rural Investments Financing

Also we realise that in the year 2013, 130 projects were finalized, with 30 projects less than in the year 2011 but with an average value higher than in 2011, Euro 390,692 by comparison with Euro 320,437 ( calculated as

the total value of the projects by year/number of projects finalized in that current year).

In Figure 1 there is a graphic representation of the projects finalized within the period 2009 – 2014, the year 2009 representing the year with the most finalized projects, and the year 2010 the year with the highest financial value of the 393 finalised projects, value that in the period 2011-2014 was within the limits of Euro 50.79 million (2013) and Euro 58.61 million in 2012, with an average value of Euro 54.73 million (calculated as a sum of the four years analysed divided at the number of years).

We have to mention that by the end of the

year 2014, the total of the payments done for the projects related to Measure 121 are represented by the payments related to the 1,407 projects finalized, payments with a value of Euro 386.81 million also by the payments related to the projects on the way of implementation. In table 3 are presented the payments in period 2008-2014.

Thus during November 2008 – December 2014, the payments done have a total of Euro 669.02 million. 2010 was the year with the greatest value paid by the beneficiaries of Measure 121, and 2013 the year with the smallest value.

Table 3. Payments made in EAFRD 2008-2014 (Euro million) - 121 Measure based upon the data provided by the Agency of Rural Investments Financing

Year/ Month	2008	2009	2010	2011	2012	2013	2014
Jan	n/a	2.87	8.37	4.82	8.81	6.42	2.92
Feb	n/a	11.75	9.39	8.60	6.93	4.86	3.68
Mar	n/a	15.43	8.51	7.97	6.34	7.48	3.06
Apr	n/a	10.37	115.34	8.26	6.67	2.52	2.60
May	n/a	9.51	8.73	6.14	4.17	1.59	3.57
June	n/a	9.39	3.50	6.90	4.69	5.43	5.06
July	n/a	5.41	13.23	8.60	9.25	8.32	7.50
Aug	n/a	10.78	0.00	10.33	8.98	6.13	7.81
Sept	n/a	8.47	18.35	7.94	8.28	4.77	8.52
Oct	n/a	9.11	9.21	10.92	0.00	4.65	9.81
Nov	1.40	15.07	8.06	8.59	14.36	0.00	14.59
Dec	n/a	12.76	10.30	13.44	6.84	8.93	15.70
<b>Total Euro 669.02 million</b>	<b>1.40</b>	<b>120.91</b>	<b>212.98</b>	<b>102.52</b>	<b>85.31</b>	<b>61.09</b>	<b>84.81</b>
<b>%</b>	<b>0.21</b>	<b>18.07</b>	<b>31.83</b>	<b>15.32</b>	<b>12.75</b>	<b>9.13</b>	<b>12.68</b>

Analyzing Table 3 we can notice that in December 2014 was paid the highest value of the year, also the highest value paid in December during the entire analysed period (2008-2014).

Also at the level of the last 4 months of 2014, the last analysed year, the payments done represented a total of 57.32 % from all the payments done at the level of the year, a situation that can indicate an accelerated or even forced absorption, this being a fact that can lead to an increase of cancelled contracts within 2015 or in the finalized projects monitoring period.

In August 2010, October 2010 and November 2013 weren't done any payments for projects financed through Measure 121.

Following the analysis done at the level of payments through EAFRD, in August 2010

were done payments only for projects financed through Axis 3 – The quality of life in rural areas and the diversification of the rural economy, Measures 312 – Support for creation and development of micro-enterprises, 313 – Improving tourism activities, 322 – Village renewal and development, improving basic services for rural economy and population and upgrading of rural heritage, payments in value of Euro 7,782 million. In October 2012, respectively, November 2013, the payments who were done through EAFRD had a value of Euro 18.55 million, of which Euro 13.36 million for projects related to Axis 3 with an accent on Measure 322 and Euro 5.19 million for Measures 112 – Setting up of young farmers and 141 – Supporting semi-subsistence agricultural holdings related to Axis 1.



The fact that no payments were done in the In August 2010, October 2010 and November 2013 doesn't mean that payment requests weren't submitted by beneficiaries, a sign of either a short term blockage of the system or of lack of funds allocated for the payments of projects. As regards the payments done in September 2010, November 2012 and December 2013 we can notice an increase over the last couple months were payments were done with Euro 5.12, 6.08, respectively, 4.28 millions, but also a decrease in regard with the immediate prior months. This thing shows the values related to the payments that weren't done in the aforementioned months.

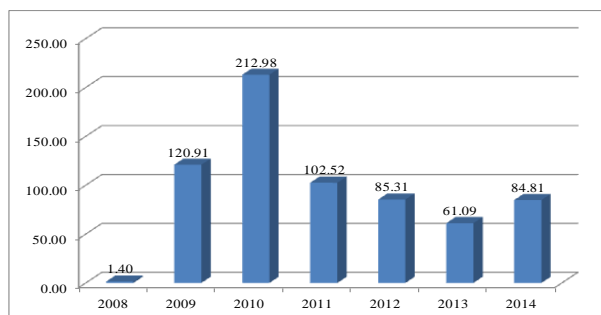

Fig. 2. Payments made in EAFRD 2008-2014 (mil. Euro) Measure 121 "Modernization of agricultural holdings" based upon the data provided by the Agency of Rural Investments Financing

In Figure 3 are graphically represented the payments done at the level of the year 2010, the year were the biggest payments wear done for the projects related to *Measure 121 "Modernization of agricultural holdings"*, payments with a value of Euro 212. 98 million.

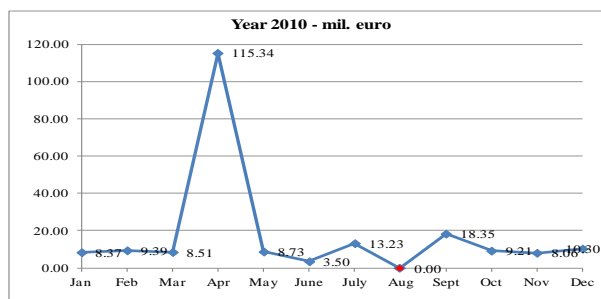

Fig.3. Payments made in EAFRD year 2010 (mil. Euro) Measure 121 "Modernisation of agricultural holdings" based upon the data provided by the Agency of Rural Investments Financing

In April is being done payments with a value of Euro 115.34 million, a value higher than

the value paid for each year 2011, 2012, 2013, 2014, as we can notice in Figure 2. In 2010 28% of the total analyzed projects were finalized with a total of 26.7% from the final value.

The payments made in 2010, represents 32% of total payments done by the end of 2014.

In Figure 4 are represented the payments related to Measure 121 done at the level of 2014, and we can notice the intensity of their growth toward the end of the year, a situation that keeps the tendency registered at the end of each year for the analysed period.

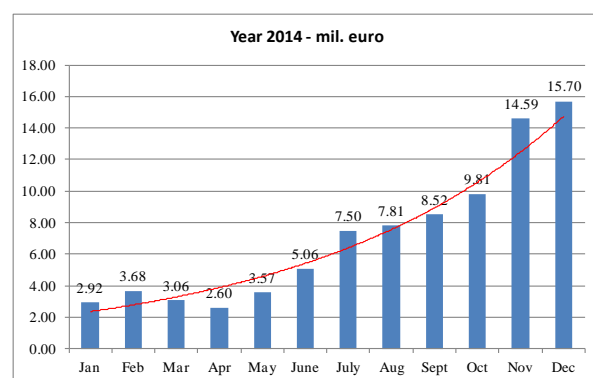

Fig.4. Payments made in EAFRD year 2014 (Euro millions) Measure 121 "Modernisation of agricultural holdings" based upon the data provided by the Agency of Rural Investments Financing

Analyzing Table 4, where the indicators of monitoring are presented related to the implementation of Measure 121 in the analysed period, we can notice that the end of 2014 80.95% of the contracted value was paid, amended with the value of the cancelled contracts, a situation that shows that the value to be paid for the current year represents 19.05% of the total, with a total of Euro 157.43 million.

The value to be paid by the end of September 2015 is with 85% higher than that paid for the entire year 2014, but also with a lower value with 26.09% then that paid for 2010, the year with the highest values paid at the level of the entire analysed period.

The 560 contracts of financed cancelled had a total value of Euro 314.36 million, of which payments in value of Euro 121.22 million were done, value to be recovered from the beneficiaries in accordance with the procedures in force.

The value of cancelled contracts is comparative with the value of concluded contracts during the analysed period 2008-2014, representing 81.27% of their total value.

Table 4. Monitoring indicators related to Measure 121 “Modernization of agricultural holdings” within the period 2008 – 2014 , based upon the data provided by the Agency of Rural Investments Financing

Measure 121 ( 2007-2013)	Value (Euro million)	%
Allocated value for 2007-2013	910.20	100.00
Selected Financing Requests value	1,250.13	137.35
Concluded contracted amended with those canceled + value for cancellation 141	826.45	66.11
Total value paid at the end of 2014	669.02	80.95
Value paid at the end of 2014 (from total value paid) relating to contracts concluded	386.81	47.00
Canceled value at the end of 2014	314.36	25.15
Value paid out of canceled contracts at the end of 2014	121.22	38.56
Value to be paid by September 30th 2015	157.43	19.05

From the total of the cancelled projects we mention that a number of 394 projects were cancelled by the agreement of the parties, (in 2014 a number of 136 projects), a number of 161 projects being cancelled for the nonobservance of the contractual clauses (in 2014 a number of 63) and a number of 5 cancelled contracts from other causes. [5]

Within the framework of the Monitoring Committee for NRDP 2007-2013, the XIII reunion that took place in June 2014, was presented the status of the implementation of Measures NRDP until May 29 2014. [6].

In table 5, it is presented the analysis of the [5]ARIF data (based on a written request) implementation stage of Measure 121, in the last six months of the year 2014.

It was noticed that in this period a number of 88 projects were finalized that represent 6.25% of the total of finalized projects and a number of 167 cancelled projects that represent 29.82 % of the total of cancelled projects.

We also noticed that the number of cancelled projects is double in regards of the number of finalized projects.

Table 5. Evolution of the projects of Measure 121 in the period June – December 2014

Measure 121	29.May 2014	31. December 2014	29 May-31 December 2014	%
Number of finalized projects	1,319	1,407	88	6.25
Number of cancelled projects	393	560	167	29.82
Value of cancelled projects/Euro million	216	314	98	31.16

## CONCLUSIONS

Measure 121 – “The modernization of agricultural holdings” was a measure with high interest from beneficiaries, in the financial period 2007-2013, with requests more than 330% out of the total value allocated.

The year 2010 was the successful year for the implementation of the projects related to Measure 121.

One of the main findings of this research document is the high number of cancelled contracts despite the high number of requests – it shows the need for a professionalization of those who apply in order to write realistic projects that take into account the financial and economic situation of the beneficiary.

An improvement of the evaluation, selection and contracting procedures is required in order to diminish the number of cancelled contracts.

Perhaps the most important cause of contracts cancellation is the lack of co-financing of projects by the beneficiaries, they having difficulties in obtaining the credits need for investments from the banks.

## ACKNOWLEDGEMENTS

This research was financed by the European Social Fund by means of the Operational Sectoral Programme Human Resources Development POS-DRU POSDRU / 159 / 1.5 / S / 132765: “Doctoral and postdoctoral programmes for the promotion of excellence in research, development and innovation in the priority areas – agronomic and veterinary of knowledge based society”.

## REFERENCES

[1]ARIF data (based on a written request).

[2]Fintineru, G., Dona, I., Fintineru, A., 2010, “The flexible approach of the second pillar on CAP to maximize advantages for EU farmers - Romania case”, Scientific Papers Series Management, Economic Engineering in Agriculture and Rural Development Vol.10(3):143-146

[3]Raport anual de progrese privind implementarea Programului National de Dezvoltare Rurala in Romania in anul 2013 – studiu MADR 2014, pag.28;

[4]Sin, A., Nowak, C., 2014, “Comparative analysis of EAFRD’s Measure 121“Modernization of agricultural holdings” implementation in Romania and Poland”, Procedia Economics and Finance 8, pp.678-682

[5]<http://www.madr.ro/pndr/comitet-de-monitorizare-pt-pndr.htm>

[6][http://old.madr.ro/pages/dezvoltare\\_rurala/nrdp-consolidated-version-june-2010.pdf](http://old.madr.ro/pages/dezvoltare_rurala/nrdp-consolidated-version-june-2010.pdf)



## STUDY REGARDING THE EVOLUTION OF FOOD CONSUMPTION OF ROMANIA DURING 2007- 2013, FROM THE PERSPECTIVE OF FOOD SECURITY INSURANCE AND EXPORT AVAILABILITY GROWTH

Denisa BURCEA, Ion DONA

University of Agricultural Sciences and Veterinary Medicine Bucharest, 59, Marasti, District 1, 11464, Bucharest, Romania, Phone: 40213182564 Fax: 40213182888, Emails: burceadenisa@gmail.com, ion\_dona@yahoo.com

*Corresponding author:* burceadenisa@gmail.com

### *Abstract:*

*Food security has become a more pressing issue for all the governments of the world who are forced to face a growing populations worldwide. But when discussing about the notion of food security one of the main issues addressed is that of food consumption. Therefore, the aim of this paper is to present the evolution of the main indicators related to food consumption in Romania and to make a brief analysis of this problem. To achieve this we used a number of indicators, such as average annual consumption per capita, average daily food consumption per person, the average annual production per capita for the main agricultural products, the average monthly consumption for the main food products. Following our analysis results led to the conclusion that besides a few exceptions, Romania has now and had during the entire period analyzed the production capacity necessary to cover the average annual consumption per capita from its own average annual production and therefore, to ensure its own food security.*

**Key words:** food consumption, agricultural production, food production, food security

### INTRODUCTION

In terms of concept, food security is seen as the need to produce more viands to provide enough food for the entire population. But this idea is incomplete because there are major differences between the needs of poor countries, underdeveloped or developing countries and the developed nations. If in the underdeveloped regions we can talk about food security insurance by increasing food production, in the developed countries to ensure food security involves more the quality of food than their quantity. Thus, the inadequate nutrition exists both in the poor countries and the rich ones (where the so-called phenomenon of "hidden hunger" comes out) [2], being classified into 3 types: *hunger*, causing calories and protein deficiency, *deficiency of microelements*, which causes the deficiency of vitamins and minerals and *overeating*, which causes excess calories often accompanied by the lack of vitamins and minerals [10]

In Romania, food security insurance policies are mainly focused on the quantitative notion,

namely, the insurance of sufficient agricultural production to cover the level of consumption of the population. Therefore we considered necessary analysis at quantitative level for the evolution of food consumption of the Romanian population, the main food and beverages, subsequently correlated with average annual production per capita for the main food products.

### MATERIALS AND METHODS

The database used is provided by the Romanian Statistical Yearbook and the website of the National Institute of Statistics - INS, specifically TEMPO online database.

The main indicators used were the average annual consumption per capita, average daily food consumption per person, the average annual production per capita for the main agricultural products. The annual average consumption of food products is calculated as consumption availability (production + import - export - industrial processing - loss - stock variation) related to the total population from July 1 of the reference period. [9]

The average daily food consumption per person is obtained by dividing the number of calories (or the amount of nutrients) corresponding the edible part of each product and per household to the number of man-days alimentation. [9]

The average annual production per capita for the main agricultural products is calculated by reporting the total quantity of agricultural products, meat, milk, wool and egg to the total population from 1 July of the year of reference. [7]

The main method used in conducting this analysis was the method of quantitative comparison over time, which can be applied by calculating the dynamic pace of the analyzed phenomenon in the time period considered. On this line, we determined the difference between the calculated percentage level of relative indices of dynamic with fixed-basis and / or variable basis and the percentage of 100%. For determining the coverage of food requirement per capita, the average annual consumption per capita was reported to the average annual production per capita, the ratio being subsequently multiplied by 100 in order to obtain the percentage evolution.

## RESULTS AND DISCUSSIONS

When considering Romania's food consumption and production possibilities in conjunction with their own consumption we must first analyze the consumption expenditure conducted by the households in our country.

It is interesting to notice the cash expenditure structure that a household allocates monthly for the necessary payments. Thus, in Figure 1 we can see that there aren't considerable differences in the distribution of total cash expenditure for major spending categories. The majority of cash expenses made monthly are those related to food, the percentage being slightly higher in 2013 compared to 2007 (with 0.4 percentage points respectively 1.12% higher). In addition, expenditure on services category increased slightly compared to 2007, rising by 0.6 percentage points (2.08%). In terms of non-food products,

consumption expenditure fell by 1 percentage point in 2013 compared to 2007. Expressed as a percentage, this decrease is:  $(1/35.4) * 100 = 2.82\%$ .

In 2007 the total income per household was 1,686.74 lei/month, reaching in 2013 a value of 2,559.1 lei/month. [6] Thus, while household income increased by 51.72% this increase was not sufficient to cover permanent increase in prices of food and services (electricity, gas, public transportation, etc.) in the period under review. Therefore it came to these evolutions of the cash expenditure distribution, the population being forced to spend more on the same amount of food and the same services offered and to give up on non-food related costs.

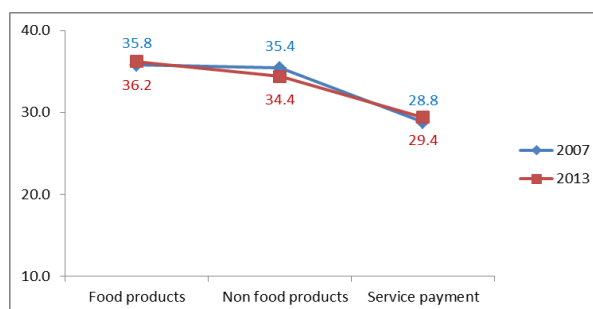

Fig. 1. Structure of monetary consumption expenditure for households - 2007-2013 (%)

Also, if we study Table 1 and the graphs made based on data from Table 1 (Fig. 2 and Fig 3), we can see increasing total consumption expenditure for the period under review, reaching the point were in 2013 to spend with 565.34 lei / month (51.18%) more than in July 20.

Although total consumption expenditure increased, the share of spendings on food products has not undergone great changes, ranging from 40.9% (in 2008 and 2009) to 41.9% (in 2012) of total expenditure, throughout the entire period under review. As a share, the level of consumption for agricultural products slightly decreased in 2013 compared to 2007, by 0.3 percentage points (Fig. 3). But there were significant changes on the physical volume of expenditure, Romanians spending in 2013 with 50.17% more on food products and soft drinks than in 2007 (Fig. 2). This increase in physical volume but decrease in percentage of

total expenses results on the one hand from the continuous increase in food prices but also from the changing consumer preferences of the population. For example, young people between 18 and 25 years, frequently prefer to consume organic products [3] that normally are more expensive due to higher production costs obtain in the case of practicing organic farming [5].

Instead, spendings on alcohol and tobacco increased continuously, the difference compared to 2007 reaching 1.3 percentage points in 2013. This is due to the introduction of new European regulations concerning alcohol and tobacco taxation and excise, regulations that had to be respected also by the legislation in Romania. These increases in excise have increased the price for this type of products, increasing physical value of expenditure with 82.38%, while the percentage growth was only by 1.3 percentage points.

If we talk about the share of each category of expenses from total consumption expenditure, from the analysis of Fig. 3 we can observe that the differences are not significant, not exceeding 1.2 percentage point increase (in the case of housing-related expenses).

There is also a decrease in the share of total expenditure, as in the case of expenses related to dwelling endowment and maintenance (-0.77 percentage points), communications (-0.4 percentage points), recreation and culture (-0.5 percentage points), education (-0.3 percentage points), the largest decrease being in the case of expenses related to clothing and footwear (-1.6 percentage points).

However, if we analyze in terms of physical volume of expenditure, there are significant differences between the structure in 2007 and in 2013. Thus, the costs related to housing the growth is 63.15% in 2013 compared to 2007, due to rising prices for electricity, gas supply, fuels, etc.

As for the costs that suffered declines as level of share of total expenditures, the only expense that decreased from the physical volume of expenditure point of view is education, which decreased by 9.02% compared to 2007.

Also, in terms of volume of expenditure,

expenses related to health increased significantly (by 75.19%), due most likely to the reorientation of Romanians to the private health system, where prices are considerably higher.

Table 1. Structure of total consumption expenditure of households 2007-2013 (lei, monthly per household)

	2007	2008	2009	2010	2011	2012	2013 <sup>1)</sup>
<b>Total consumption expenditure</b>	<b>1104.70</b>	<b>1365.36</b>	<b>1468.60</b>	<b>1486.43</b>	<b>1532.29</b>	<b>1614.10</b>	<b>1670.04</b>
<b>Food products and soft drinks</b>	460.93	558.25	600.94	608.64	639.36	676.77	692.18
Alcoholic beverages, tobacco	71.79	89.55	103.92	113.91	116.52	125.15	130.93
Clothing and Footwear	74.63	91.28	88.01	80.55	76.9	81.17	87.15
Housing, water, electricity, gas and other fuels	171.17	213.17	232.37	246.85	250.09	268.88	279.27
Furniture, dwelling endowment and maintenance	51.05	65.29	67.27	59.44	61.31	61.97	64.9
Health Care	42.48	55.59	65.63	67.42	71.18	70.08	74.42
Transport	65.48	84.14	84.56	89.29	92.34	99.13	98.45
Communications	56.45	67.89	74.87	73.8	72.12	76.87	78.62
Recreation and culture	51.06	61.27	64.92	59.54	61.75	60.94	67.79
Education	8.54	11.32	13.93	10.81	9.54	9.78	7.77
Hotels, cafes and restaurants	13.33	18.95	18.6	19.06	19.74	20.82	24.45
Miscellaneous goods and services	37.79	48.67	53.58	57.12	61.44	62.51	64.11

Also, a significant increase in spendings occurred in terms of transport expenditures (50, 35% higher than in 2007) and the costs of hotels, cafes and restaurants (with 83.42% higher than in 2007).

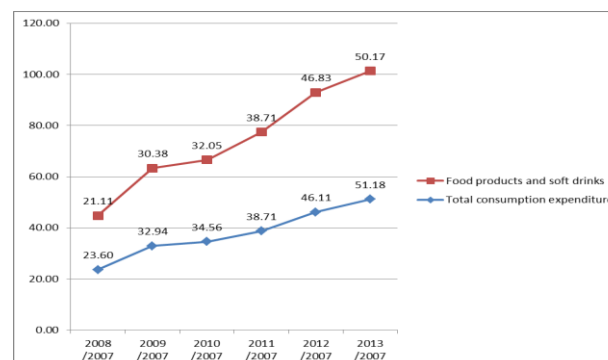

Fig 2. Dynamics of total consumption expenditure and of food products and soft drinks, in 2007-2013 (%); <sup>1)</sup>Provisional data.

Source: TEMPO online

These increases are due both to the increase in fuel prices and hospitality services, and to changed preferences of residents. Thus, the



Romanians began to prefer traveling by private car to the detriment of means of transport and began to have higher expectations in terms of hospitality of restaurants, hotels and cafes, preferring to pay more for better service.

The high level of poverty, but also their remaining reminiscents from the period when there was a shortage of products, leads many to sacrificing product quality for quantity and often detrimental to health.

Analyzing statistical indicators related to consumption, there are indications that the conduct of Romanians to orient more towards the quantity than to the quality of food

products is gradually changing. This can be seen from Tables 2 and 3 that shows the average monthly consumption for the main food and beverages and it's evolution compared to the base year 2007.

Analyzing Table 2 concerning the average monthly individual consumption for the main food and beverages, and Table 3 concerning the average monthly consumption trends compared to the reference year 2007, we see a continued evolution of the consumption for the main food products. For example, meat consumption had a linear increase since 2007, reaching in 2013 to be with 9.52% higher than in 2007.

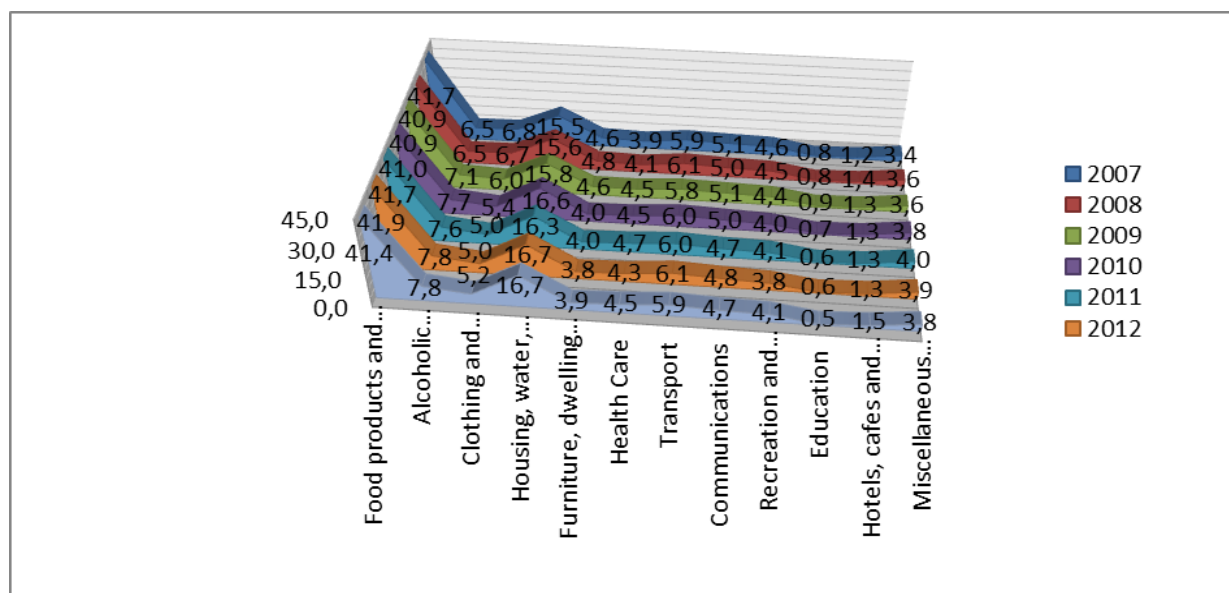

Fig. 3. Total monthly consumption expenditure in 2007-2013 by households, by category of expenditure (%)

In exchange, the consumption of meat products has decreased in recent years compared to 2007 people orienting itself more on the consumption of fresh meat. Thus, in 2013 there was a monthly average consumption per capita by 1.81% lower than consumption in 2007. This is explained by the fact that with the entry into the EU area Romania and the increasing access to information on the processing of food products, Romanians began to prefer consumption of fresh products, as little processed as possible.

Also, fat consumption has likewise seen a decrease from 2007, being in 2013 by 4.56% lower than the reference year 2007.

Unfortunately, as a consequence of the milk

crisis in recent years, of the quotas imposed by the EU and the constant increase in the milk price, average monthly consumption of this basic food product suffered significant declines towards the end of the analysis period, being in 2013 with 3.29% lower than in 2007.

Returning to the Romanians tendency in recent years to eat fewer processed foods, the category of vegetables and fruits has also known an increase compared to 2007 in terms of consumption. Thus, in Table 3, concerning the average monthly consumption trends in 2007-2013, in 2013 the growth in those type of products was by 8.20% for vegetables and by 11.98% for fruit.



Table 2. Average monthly consumption <sup>1)</sup> for the main food products and beverages

	MU	2007	2008	2009	2010	2011	2012	2013
Fresh meat	kg	2.91	3.07	3.12	3.10	3.08	3.14	3.19
Meat products	kg	1.05	1.11	1.11	1.07	1.02	1.04	1.03
Fats	kg	1.25	1.24	1.23	1.22	1.20	1.20	1.19
Milk	l	6.07	6.15	6.17	6.19	5.96	6.06	5.87
Eggs	pc	12.98	13.07	13.06	12.99	13.15	12.81	13.38
Sugar	kg	0.78	0.76	0.76	0.75	0.74	0.73	0.75
Potatoes	kg	3.64	3.61	3.59	3.49	3.47	3.48	3.31
Vegetables and canning vegetable	kg	7.04	7.31	7.63	7.38	7.60	7.58	7.62
Fruits	kg	3.08	3.31	3.55	3.56	3.40	3.39	3.45
Mineral water and other soft drinks	l	4.26	4.83	4.82	4.86	4.57	4.54	4.49
Beer	l	1.08	1.20	1.17	1.11	1.08	1.13	1.21
Wine	l	0.91	0.93	0.97	0.94	0.86	0.87	0.88
Plum brandy and natural brandy	l	0.21	0.22	0.23	0.22	0.22	0.21	0.21

<sup>1)</sup> Monthly average amounts per person (in individual households).

Source: NIS

With the entry into the EU and the imposition of more restrictive rules on alcohol, combined with increased excise duty on alcoholic beverages, the drinking of wine, plum brandy and natural brandy fell by 3.74% respectively 1.9% in 2013 compared to 2007.

However, with the decreasing alcohol consumption for the categories mentioned above, beer consumption relatively increased

over the period of analysis, being in 2013 with 11.57% higher than in 2007. This increase can be explained by Romanians tendency and general preference for beer over other alcoholic beverages linked to the price which is generally lower than other alcoholic beverages but also linked to the diversification in recent years of the types of beers sold in Romania.

Table 3. Evolution of the average monthly consumption 2007 -2013

Fixed Base 2007	MU	2008 /2007	2009 /2007	2010 /2007	2011/ 2007	2012 /2007	2013/ 2007
Fresh meat	%	5.50	7.04	6.63	5.81	8.01	9.52
Meat products	%	5.81	5.33	1.71	<b>-2.57</b>	<b>-1.14</b>	<b>-1.81</b>
Fats	%	<b>-0.96</b>	<b>-1.76</b>	<b>-2.48</b>	<b>-3.92</b>	<b>-4.32</b>	<b>-4.56</b>
Milk	%	1.33	1.61	1.91	<b>-1.78</b>	<b>-0.13</b>	<b>-3.29</b>
Eggs	%	0.65	0.58	0.08	1.27	<b>-1.35</b>	3.05
Sugar	%	<b>-2.69</b>	<b>-2.82</b>	<b>-3.33</b>	<b>-5.00</b>	<b>-6.15</b>	<b>-4.49</b>
Potatoes	%	<b>-0.71</b>	<b>-1.48</b>	<b>-4.18</b>	<b>-4.81</b>	<b>-4.40</b>	<b>-8.96</b>
Vegetables and canning vegetable	%	3.76	8.34	4.86	7.91	7.60	8.20
Fruits	%	7.53	15.32	15.49	10.36	10.03	11.98
Mineral water and other soft drinks	%	13.45	13.17	14.06	7.30	6.62	5.38
Beer	%	11.20	7.87	2.96	<b>-0.28</b>	4.17	11.57
Wine	%	2.53	6.48	3.52	<b>-5.05</b>	<b>-3.96</b>	<b>-3.74</b>
Plum brandy and natural brandy	%	6.67	9.52	3.81	3.33	<b>-2.38</b>	<b>-1.90</b>

In terms of individually average daily consumption, depending on the number of calories and nutrients consumed, it can be seen a slight downward trend. This

consumption is shown in Table 4: "The average daily food consumption per person, per components of consumption."

Thus, if we talk about the number of calories consumed daily by a person, there is a small decrease, the lowest value being in 2012 when a Romanian consumed 73.3 less calories compared to 2007.

Bearing in mind the fact that the daily requirements recommended by nutritionists and regulated by the state for children and

adolescents up to 19 years, for example, is in the range of 1500-3500 calories per day [4], we notice that despite the decline average number of calories consumed daily, the Romanian population is approaching however the extreme top of the recommended daily requirement.

Table 4. Average daily food consumption per person, per components of consumption

Food components - calories and nutrients	MU	2007	2008	2009	2010	2011	2012	2013
Calories	Number	2473	2484.3	2487	2445.8	2405.8	2399.7	2402.9
in which								
Animal origin	Number	600	620.9	621.9	617.8	609.1	616.6	618.5
	%	24.26	24.99	25.01	25.26	25.32	25.69	25.74
Protein	Grams	81.8	82.8	83.1	81.8	80.7	80.8	81
in which								
Animal origin	Grams	38.2	39.7	40.3	40	39.2	39.6	40
	%	46.70	47.95	48.50	48.90	48.57	49.01	49.38
Lipids	Grams	83.6	85	85.2	84.3	82.8	83.1	83.5
in which								
Animal origin	Grams	41.8	43.3	43	42.7	42.2	42.7	42.9
	%	50.00	50.94	50.47	50.65	50.97	51.38	51.38
Carbohydrates	Grams	318.8	316.6	316.4	310.1	305.5	303.2	302.6

Source: NIS

If this trend will continue in the next period and no action will be taken for reducing the number of calories, the number of overweight people will increase withal.

A negative aspect is the increasing percentage of calories from animal origin in total calories, going in 2013 to 25.74% of total average daily consumption of calories, with 1.48 percentage points more than in 2007.

The protein level of animal origin consumed by a person daily increased in percentage by 2.68 percentage points in 2013 compared to 2007.

The fats level of animal origin consumed by an individual daily increased in percentage up to 1.38 percentage points in 2013 compared to 2007.

Regarding individual average daily consumption of carbohydrates, it has been in a continuing downward trend over 2007-2013, in 2013 coming to be by 5.08% (16.2 grams) lower than in the reference year 2007 ( Fig. 4).



Fig. 4. The dynamics of average daily consumption per person, per components of consumption, in 2007-2013 (%)

In terms of quality, despite the decline of daily carbohydrate level with 5.08%, the quality of daily consumption of nutrients is still problematic. This is because there are differences between the quality of food consumption in different social categories of consumers, differences created by different levels of income. [3]

Table 5. Average annual production for the main agricultural products per capita

Main agricultural products	MU	2007	2008	2009	2010	2011	2012	2013
Cereal grain	Kg	374.2	819.3	730.2	825.5	1034.5	639.3	1045.7
Potatoes	Kg	177.8	177.7	196.6	162.2	202.3	122.9	164.6
Vegetables	Kg	149.3	186	191.6	190.8	207.3	176.2	198.2
Fruits	Kg	52	57.4	65	70.1	73.5	56.3	65.1
Meat	Kg	72	69.4	70.8	64.5	67.4	66.4	65
Milk	Liters	292.3	287.3	276.8	242.7	248.5	241	243.8
Eggs	Buc	312	326	305	306	314	319	320

Source: NIS

Table 6. Average annual consumption per capita, for the main products

The main food products	MU	2007	2008	2009	2010	2011	2012	2013
Cereals and cereal products in grain equivalent	Kg	213.4	213.6	211.7	211.3	217.7	208.5	218.1
Potatoes	Kg	99.1	104.2	98.1	103.9	103.3	104.7	103
Vegetables and vegetable products	Kg	149.9	158.9	148.7	155.7	162.9	151.4	152
Fruits and fruit products	Kg	69.9	69.8	65.7	67	74.7	71.1	73.7
Meat and meat products	Kg	64.7	66	67.3	59.9	56	55.3	54.4
Milk and dairy products (excluding butter)	Liters	268.6	274.6	253.2	244.2	248.5	241.1	244.5
Eggs	Buc	276	280	256	253	264	245	247

Source: NIS

We must analyze, however, what happens in terms of quantity with the Romanian population consumption. Therefore, using tables 5, 6 and 7 we performed an analysis of the coverage of food requirements per capita.

This degree of assurance from own resources was determined by dividing the average annual consumption per capita for the main food products (data from Table 6) to the average annual production of the main agricultural products per capita (data from Table 5).

Data obtained from this report represents the percentage of consumption from own production of the main agricultural products and the results are found in Table 7.

Following the analysis of Table 7 we can observe that in terms of cereals Romanians

reached a point of coverage ensurance of domestic consumer demand rather high (from 57.03% of production in 2007 to only 20.86% of production in 2013), due mostly to the significant increase in average annual production volume per capita, to 1045.7 kg / person / year in 2013.

For the potatoes it can be observed a consumption of around 50% of the average annual production over the entire period, with consumption growth trends in recent years, but these increase is mainly due to production decrease.

Regarding vegetables, if at the beginning of the analysis period we consumed by 0.40% more than we produced at individually level, the situation has improved gradually, as in 2013 to consume 76.69% of what we produce. This was possible due to continued growth in the production of vegetables.

Table 7. Percentage of average annual consumption from average annual production per capita

The main food	MU	2007	2008	2009	2010	2011	2012	2013
Cereals and cereal products	%	57.03	26.07	28.99	25.60	21.04	32.61	20.86
Potatoes	%	55.74	58.64	49.90	64.06	51.06	85.19	62.58
Vegetables and vegetable products	%	100.40	85.43	77.61	81.60	78.58	85.93	76.69
Fruits and fruit products	%	134.42	121.60	101.08	95.58	101.63	126.29	113.21
Meat and meat products	%	89.86	95.10	95.06	92.87	83.09	83.28	83.69
Milk and dairy products (excluding butter)	%	91.89	95.58	91.47	100.62	100.00	100.04	100.29
Eggs	%	88.46	85.89	83.93	82.68	84.08	76.80	77.19

In the case of fruit, intervention is required, as people began to consume more and more fresh fruits or fruit products, but production has not increased in line with demand, thus leading to a situation where we consume much more than we produce.

In 2009-2011 the gap between consumption and production has decreased, but this happened due to lower consumption level of the population and less to the growth of average production per capita.

## CONCLUSIONS

In the past decade the level of consumption in terms of quantity has increased, Romania getting to have a consumption close to the quantitative average of the European Union.

In terms of quality consumption there have been improvements as against the periods before the entry into the Union, trying as much as possible to comply to the rules recommended by experts in nutrition. Unfortunately, even today one cannot say that Romania has come to ensure a high level of food safety, food consumed by the population is either insufficient (which is the case of fruit and fruit products) or in sufficient quantity but of poor quality (talking here about nutrient content of foods consumed by the population of Romania).

It is necessary to improve methods of correlation the consumption behavior of our own population to the type of food that we produce and their production levels.

From the data processed in this paper we conclude that Romania has the capacity to ensure their food security. The country provides it's necessary resources from it's own sources, especially in the case of cereals, potatoes and vegetables.

Given the coverage of domestic consumer demand for foodstuffs it results a high availability for export, with the exception of two categories of products: fruits and fruit products and milk and milk products, where we do not have yet sufficient production to cover domestic consumption of the population.

## AKNOWLEDGEMENTS

This paper was published under the frame of European Social Found, Human Resources Development Operational Program 2007–2013, project no. POSDRU/159/1.5/S/132765.

## REFERENCES

[1]Alec, I., Constantin, M., Necula, R., 2014, The comparative structure of agrifood productis consumption in Romania, Scientific Papers Series

Management, Economic Engineering in Agriculture and Rural Development Vol. 14(1):7-12

[2]Brown, L., 2000, Starea lumii 2000, Editura Tehnică, Bucharest

[3]Dinu, T., A., Stoian, E., Micu, M.M., Condei, R., Alecu, I.N. 2014, Study regarding consumption of organic products in Romania, Scientific Papers Series Management, Economic Engineering in Agriculture and Rural Development Vol. 14(2):113-118

[4]Ministry of Public Health, 2008, Order approving the list of recommended foods and pre-school children and the principles that underpin a healthy diet for children and adolescents, Annex 3 A. The daily calories and nutrients for children

[5]Muscănescu, A., 2013, Organic versus conventional: Advantages and disadvantages of organic farming, Scientific Papers Series Management, Economic Engineering in Agriculture and Rural Development Vol. 13(1): 253-256

[6]National Institute of Statistics, 2014, Romania in figures 2014 – Statistical abstract, INS, Bucharest

[7]National Institute of Statistics, Data base, <http://www.insse.ro/>

[8]National Institute of Statistics, - TEMPO Online database, [www.statistici.insse.ro/shop/](http://www.statistici.insse.ro/shop/)

[9]Statistical Yearbook of Romania, 2012

[10]Zahiu, L., Dachin, A., 2001, Politici agroalimentare comparate, Editura Economică, Bucharest, p. 58.

## STUDY ON THE EVOLUTION OF THE HOP MARKET IN ROMANIA DURING THE PERIOD 2007-2014

Irina-Adriana CHIURCIU

University of Agricultural Sciences and Veterinary Medicine Bucharest, 59 Marasti, District 1, 011464, Bucharest, Romania, Phone: +4021 3182564, Fax: +4021 3182567, Mobile: +40723 548814, Email: irina.chiurciu@yahoo.ro

*Corresponding author:* irina.chiurciu@yahoo.ro

### Abstract

*The aim of this article is to present the evolution of hop market during the period 2007-2014 in Romania. It is based on the statistical data provided by the National Institute of Statistics and by the Ministry of Agriculture and Rural Development. The indicators used for processing the data are the following: the total production, the cultivated areas of hop and the quantity of hop imported and exported. From the analysis of the results obtained we can observe a decrease of 69.51% in 2012 from the total production in comparison with 2007. In the last years of the period in study, from 2012 to 2014, it increased by 104.4%. However the inland production is insufficient for the local beer industry. Romania has to import vast amounts of hops to ensure the brewers requirements across the country.*

*Key words:* evolution, hop, production, Romania, surface

### INTRODUCTION

Although it is cultivated on small areas in our country due to climatic requirements and high production costs, the hop is an important technique plant because it represents the raw material for the beer production [2]. Hop culture technology requires special conditions of temperature and humidity; it also needs 10 to 12 irrigations per year, while the first harvest is obtained 3 years after the plantation.

The favorable areas for the hop culture are situated in the heart of Transylvania, in Alba, Cluj, Brasov, Mures, Hunedoara and Sibiu. In 2014, in Romania the hop was cultivated on 245 hectares resulting a production of 233 tons.

The varieties of beer hop grown in Romania are: Brewers Gold, Magnum and Taurus.

Worldwide, the trend is represented by the reduction of the hop cultivated surfaces even though the beer production is growing, especially the aromatic one in detriment of the bitter one [1].

The decrease of hop surfaces is related to the demand for less bitter beers, which requires a low content of alpha acid, the bitter component of the hop who gives beer its taste. EU is the major exporter of hop on the world

market and has 60% of the cultivated area. The main producing Member States are Germany (60% of EU land and around 1/3 worldwide), the Czech Republic, Poland, Slovenia, UK, Spain, France [1].

The main importer is Russia, followed by the United States and Japan.

### MATERIALS AND METHODS

In order to characterize the evolution of hop production, the following indicators were used: the area cultivated with hop in our country between the years 2007-2014, the total production of hop for the same period, the repartition of surfaces cultivated by counties in 2013 in comparison with 2007, the repartition of hop production in 2013 in comparison with 2007, the quantity of hop imported and exported between the years 2007-2014, as well as the price.

The data, collected from Ministry of Agriculture and Rural Development and the National Institute of Statistics have been statistically processed and interpreted.

### RESULTS AND DISCUSSIONS

Market organization covers both hops and hop products from the following: cones, hop

powder, hop powder with higher lupulin content, extract of hops, mixed hop products used in brewing. Hop market in the European Union is subjected to the following regulations: Regulation (EC) no. 1307/2013 of the European Parliament and of the Council; Regulation (EC) no. 1308/2013 of the European Parliament and of the Council; Regulation (EC) no. 792/2009 of the Council which establishes the rules [3].

Worldwide there is an international association of hop, IHGC- International Hop Growers' Convention, which consists of 32 members (countries, organizations or associations of growers), including Romania [4]. Because there is a stock, the price is formed on the basis of supply and demand, following annual assessments of IHGC, the main producers, Germany and the US, having a word in the establishment of the price.

In Romania, the leadership and the management of market are controlled by M.A.R.D. through the Technical Inspection Bureau of hop and hop products (established by Law no.627/2002); Hop Advisory Council and Hop Producers Association of Romania (made up of five producers). The national legislation includes the Law no. 627/2002; Order no. 172/2003; Order no.623/2002; Order no.74/2004.

The hop surface in Romania has increased until 1990 when it reached 2350 ha, with average yields of 11, 2 q/ha. Unfortunately, after 1990 the surfaces and the hop production decreased significantly (in 1995- 1,727 ha, in 2000- below 500 ha, in 2014 - 245 ha), one of the causes is infrastructure's degradation of the metallic systems for supporting hops.

Forms of support: support schemes financed from the Community budget (payment per area); support schemes financed from the national budget (national aid); State aid schemes (fuel). For 2014 MARD established a quantum of transitional national aid in the vegetal sector of 19.81 euro/ha. For the increase of surfaces cultivated with hop, this aid is supplemented with payments which represent specific transitional national aid, decoupled from production of 335.00 euro/ha [5].

If in 2007 in Romania were cultivated 440 ha

of hop, in 2014 the cultivated area reached 245 ha. For the analyzed period (2007-2014) the maximum is 501 ha in 2008, and the minimum is 215 ha in 2010 [5]. Starting with the year 2010 there is a slight increase of the areas cultivated with hop from 215 ha to 245 ha meaning that it increased by 12.24% (Fig. 1).

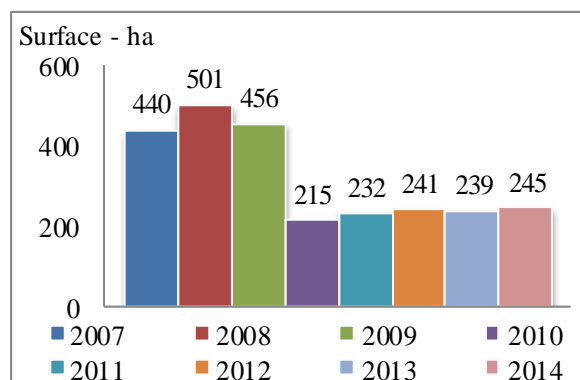

Fig. 1. The evolution of the surfaces cultivated with hop during 2007-2014 in Romania

Source: Site of MARD, Site of National Institute of Statistics

The total production of hop has recorded a decrease starting with 2007 from 374 tons to 114 tons in 2012. Starting with 2013 the total production increases from 172 to 233 tons [5]. This is due to the increase of the cultivated areas (Fig. 2)



Fig. 1. The evolution of the total production of hop in Romania for the analyzed period

Source: Site of MARD, Site of National Institute of Statistics

In 2007 the situation of the cultivated areas was the following: in Mures County- 420 ha meaning 95% of the total of 440 ha, the rest of 20 ha in Sibiu County. In 2007 there were no hop plantations in Alba County. By comparison, in Mures County the cultivated

areas have decreased by 56.90% from 2007 to 2013, in Sibiu County the rest of the surface remained constant - 20 ha, and in Alba County new plantations were founded on 38 ha [6].

In 2013 a surface of 239 ha was planted with hop of which 181 ha in Mures County, 20 ha in Sibiu County and 38 ha in Alba County, meaning Mures County - 76%, Alba County - 16% and Sibiu County - 8% (Fig. 3).

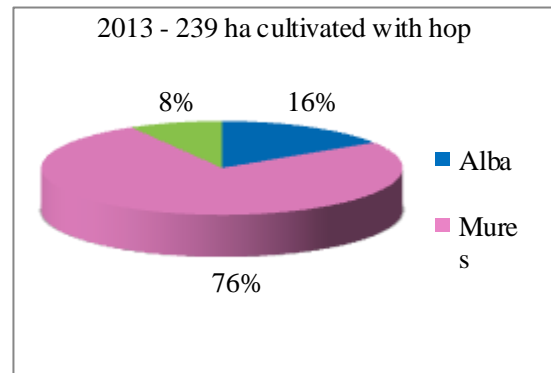
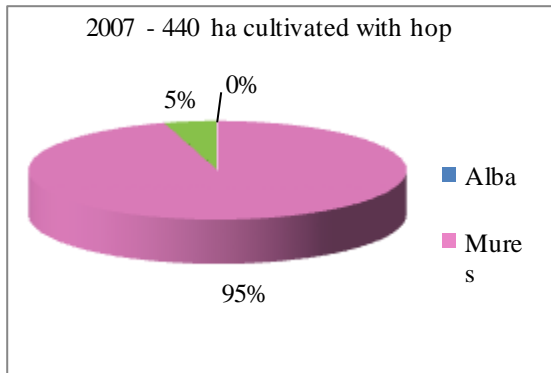

Fig. 2. The distribution of the hop cultivated surfaces in 2007 in comparison with 2013  
Source: Own calculation.

In 2007 the production of 374 tons was assigned as the following: 89% in Mures County - 334 tons and 11% in Sibiu County - 40 tons. In comparison with the production from 2013, we see that in Mures County it decreased by 60.48% and in Sibiu County by 25%.

From the total of 172 tons produced in 2013, 10 tons were harvested from the plantations established in Alba County, 132 tons in Mures County and 30 tons in Sibiu County [6]. This means 17% - Sibiu County, 6% - Alba County and Mures County - 77% (Fig.4).

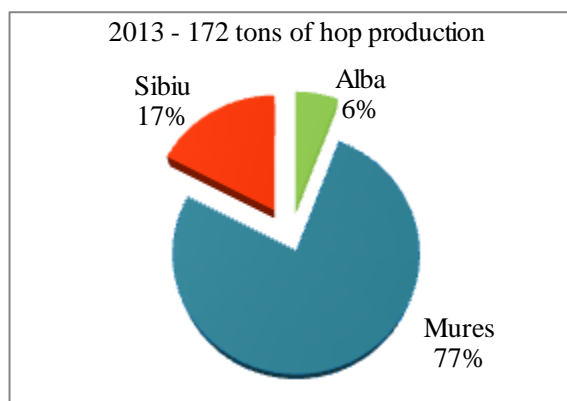
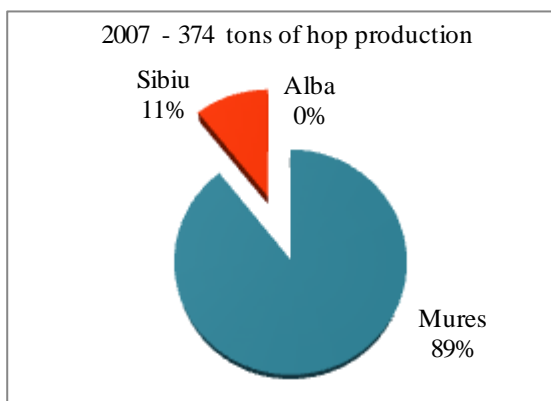

Fig. 4. The distribution of the hop production in 2007 in comparison with 2013  
Source: Own calculation.

Analyzing the intra and extra trades (Table 1) shows that in 2013 the amount of imported hops decreased by 34.32% in comparison with 2011, summing 3,066.49 thousand euros. This decrease is due to the increase of hop surfaces from 231 ha to 239 ha. The largest amount imported was recorded in 2008 - 1,257.28 tons. Regarding exports, Romania is not a competition for

the exporters, with exports up to 21.65 tons in 2008, 0.29 tons in 2012 and 0.00 in 2013. In figure 5 is represented the price evolution for the imported hop so it can be concluded that the price per ton of hop registers an increase by 30.03% between the years 2007-2010, and after that an increase by 29.28% between 2011-2013.



Table 1. The situation on the hop imports and exports from 2007- 2013 in Romania

Year	Import Amount (tons)	Import Value (thousand euro)	Export Amount (tons)	Export Value (thousand euro)
2007	629.19	5,724.37	17.97	137.07
2008	1,257.28	12,261.71	21.65	142.27
2009	357.84	4,627.50	0.02	0.14
2010	280.32	3,644.83	25.42	41.71
2011	328.57	3,301.99	0.80	2.97
2012	233.47	2,707.12	0.29	5.77
2013	215.79	3,066.49	0.00	0.00

Source: Customs National Authority and the N.I.S.

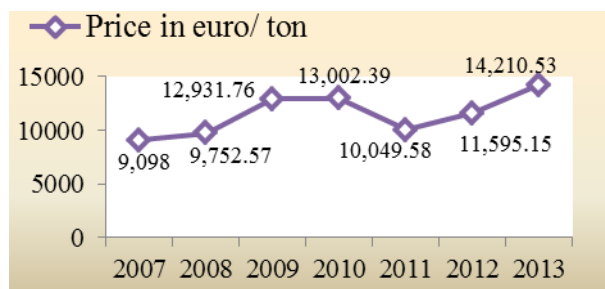

Figure 5. The price evolution for the imported hop during 2007-2013 in Romania

Source: Own calculation.

## CONCLUSIONS

The analysis of the hop market in Romania in the period 2007-2014 showed the following:

- The surface cultivated with hop has decreased during 2008-2009, with a negative impact on the production. Starting with 2010 there is a slight increase of the cultivated area from 215 ha to 245 ha in 2014;
- Total production of hop decreased by 69.51% in 2012 compared to 2007. In 2014 stands a doubling of the total production in comparison to 2012 due to the climate conditions and to the young plantation having the first harvest;
- In 2007 the surface of hop from Mures County represented 95% of the total surface, and in 2013 it dropped to 76%. While in Sibiu County the surface remained constant, in Alba 38 ha of the young plantations were having the first harvest in 2013;
- Compared to 2007, in 2013 the contribution to the total production of hop from Sibiu County increased from 11% to 17%, while for Mures it decreased from 89% to 77%;
- The inland production of hop covers only 15% of the local beer industry so Romania needs to import hop. In terms of imports it

can be noticed a decrease in 2013 compared to 2007 from 629.19 tons to 215.79 tons;

- Since 2011 the price of imported hop increased from 10,049.58 euro/ton to 14,210.53 euro/ton in 2013;
- In terms of exports, the quantities are insignificant. In 2013 Romania hasn't exported hop.

In conclusion, the hop is an important culture for both the brewing industry and the zootechnics, as well as for the pharmaceutical industry.

It is necessary that EU continues providing the income supports through decoupled payments as the bounties are more effective in hop sector.

Romania has to extend the hop cultivated surfaces by applying appropriate agricultural policies and to support the young plantations till the first harvest.

## REFERENCES

- [1] Cernea S., 2013. Situation of hop culture and beer production in the world. Hop and medicinal plants, Year XXI, No. 1-2 (41-42), 16-21
- [2] Duda M.M., Rusu T., Vârban D.I., Muntean L., Muntean S., Moldovan C., B Duda B.M., 2013. Climate monitoring of hops in Seleuş, Sighişoara area, Romania. Hop and medicinal plants, Year XXI, No. 1-2 (41-42), 26-30
- [3] Site of the European Union - [www.europa.eu](http://www.europa.eu)
- [4] Site of IHGC - [www.hmelj-giz.si/ihgc/obj.htm](http://www.hmelj-giz.si/ihgc/obj.htm)
- [5] Site of M.A.R.D. - [www.madr.ro/culturi-de-camp/plante-tehnice/tutun-si-hamei.html](http://www.madr.ro/culturi-de-camp/plante-tehnice/tutun-si-hamei.html); date operative 2007-2014, AGR 2B
- [6] Site of National Institute of Statistics - [www.insse.ro](http://www.insse.ro) AGR 108 A, AGR 109 A



## QUESTIONNAIRE ON FOREIGN LANGUAGE LEARNING STYLES FOR BUSINESS AND ENGINEERING STUDENTS

Suzana Carmen CISMAS<sup>1</sup>, Claudia MIHALCEA-CODREANU<sup>2</sup>, Gabriela ANDREIASU<sup>3</sup>, Anca Gabriela DIACONU<sup>4</sup>

<sup>1</sup>The University of Agronomic Sciences and Veterinary Medicine of Bucharest, 59 Mărăști Blvd, District 1, 011464, Bucharest, Romania, Email: suzanacismas@yahoo.com

<sup>2</sup>The National University of Music Bucharest, 33 Stirbei Voda Street, District 1, 010102, Bucharest, Romania, Email:claudia\_codreanu@yahoo.com

<sup>3</sup>The Polytechnic University of Bucharest, 313 Splaiul Independentei, District 6, Bucharest, Romania, Email: gabriela\_bucata@yahoo.com

<sup>4</sup>Cantemir Voda National College, 60 Dacia Blvd, District 2, 020061, Bucharest, Romania, Email:anca2411@yahoo.co.uk

**Corresponding author:** suzanacismas@yahoo.com

### Abstract

*Our current approach offers an opportunity to analyse the trends in a wide range of educational topics, policies and best practice over the past decade and to assess the challenges lying ahead. We hope that this body of data and information will serve as a valuable source for decision makers in various education areas. Reviewing and reforming educational strategies need to be performed so as to ensure access to high quality instruction and training for all citizens, thus facilitating long-term socio-economic growth and stability. This study analyses the main young adult English learning styles & strategies used in acquiring and improving the communicative competence in English for effectively meeting the demands of the future career. The labour market nowadays is characterized by rapid changes in technology, spectacular developments, higher standards and unprecedented mobility and comfort. All these have essentially changed the way we live and communicate, generating the need for lifelong learning, not only for jobs, but also for active and creative adaptation to the rhythm of common daily life. Foreign language(s) communication competences, as well as computer skills, are indispensable for meeting the current employment standards.*

**Key words:** business engineering, foreign language acquisition, learning styles, project work, questionnaire

### INTRODUCTION

The novelty brought by the current research is the analysis of a wide range of subjects (1764) questioned on current issues in the national Baccalaureate exam, the English language test, over a decade [17]. The study aimed at giving a glimpse on the evolution of such assessment at a turning point [25], within the maturity exam, between secondary & tertiary education in our country, as a EU member.

Student perceptions were investigated, regarding the evaluation and certification of language skills [4], which were, in turn, compared to active labour market classifications, both in national and international contexts.

Relying on extensive theoretical & bibliographic apparatus, this investigative

approach examined the degree of modernization & updating in text-books, curricula, content & methods of integrated practice for modern language skills. [8, 13, 24]

During the analysis, it became obvious that the study skills & the intellectual work styles learners use must become more flexible, more efficient, more clearly defined and more logical, shifting focus from 'what I know' to 'what I can do', from memorizing data to skills use.

The trend is fostering individual professional development via responsible use of two inter-related instruments, English & computers. Improving study skills and specific working methods in the studied languages and cultures will bring added value and effectiveness.

Progress can be achieved by facilitating

student exchanges that speed up liberalization of compatible mentalities on global education markets, where all academics already notice harsh competition for students and resources. [19]

The young adults will be able to learn through-out life; they will become self-confident and flexible, expressing personal views coherently; thus an informed electorate will be created, able to make constructive decisions. [7]

Hence [14] project work emerged as the best suited method for cultivating foreign skills.

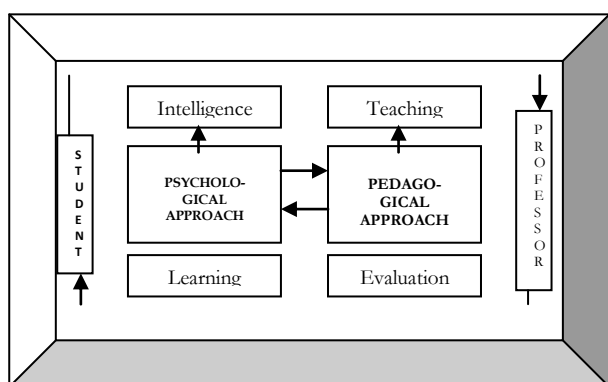

Fig.1. Project work didactic approaches [1]

This research design intended to define the concepts used in the Romanian system and to contextualise the evolution of English testing over a decade of curriculum changes & challenges.

*The purpose of the scientific investigation was to develop a framework for analysis & improvement in the national Bacalaureate exam, by synchronizing the sample of foreign language requirements with international forms of testing and certification of language skills, as well as with the Europass Language Passport standards, consistent with the prospect of its current use in secondary & tertiary education. [21]*

The aim was to highlight the learning outcomes and discuss the increasing concerns on learners' mental & physical health, alongside with finding the measures to mitigate administrative stress.

## MATERIALS AND METHODS

The method used was the questionnaire [18,

20], reporting the interlocutors' viewpoints on the realities evoked by a wide range of open & closed questions, some with multiple choice answers. The items were designed to stimulate the production of qualitative information [3, 21] on institution progress, curriculum reform and individual experience in academic & professional interest areas.

- The questionnaire yielded broad perceptions of reality, investigated by extending the scope to relevant professional fields. It was intended to ensure continuity of training in foreign languages, from college to university education, targeted to the specific jobs requirements (with feed-back involving policy makers, students, teachers, employees, and employers).

- In the whole study, of which, here, we analyse learning styles, we measured these issues:

1. performance & preference shares in various school populations: rural/urban, college/university, technical studies/humanities
2. impact of the intellectual work style on students' results and on their overall health
3. development and integration of the four communication skills in the foreign language
4. optimizing implementation of CEFR testing
5. pace of content modernization and standardized assessments implementation
6. degree of learning motivation and its limits

- The investigated sample consisted in 1764 respondents covering a wide range of categories: 74% pupils and students, employees, 5% young researchers, 9% graduates, 12% doctoral students. It covered 86% tradition & reputation universities, and 14% recently established ones.

- The results showed that pupils, students and graduates report reduced levels of interest and motivation for study and lifelong learning; they are skeptical about the prospects & employment opportunities, and often fall victim to overload, as a result of ineffective intellectual work styles or unrealistic expectations and targets they set for themselves. The collected data outline the ameliorative measures derived from the coping strategies indicated by those

questioned. The analysis pointed to significant positive correlations among stress, motivation, coping strategies and results.

- Interpretation: The rate of dissatisfaction is high throughout academia, and inadequate services persist. Targeted actions must address the problems and involve industry professionals with teaching experience.

- Needs assessment will be used as a proactive way of exploring the specific requirements of certain categories in the population who feel that school should expand, thus identifying, analyzing and preventing the dissolution of professional competence and authority, responsible for ensuring product quality from educational perspective. The analyzed data showed that a major obstacle remains the lack of economic and social support.

- According to the research objectives methodological recommendations were outlined for improving teaching, learning and assessment in foreign language education and for identifying ways to modernize and synchronise Romanian study programs with EU directives on acknowledging qualifications on the labour market, so that new professionals might become flexible and adaptable to modern requirements, in a globalised knowledge economy.

- Conclusion: the information obtained after the completion of this empirical study has the potential to support individuals, institutions and policy makers in their efforts to develop constructive solutions to such problems.

- Research limits and constraints:

- Numerous respondents
- The dimensions of the questionnaire
- Rich and varied content investigated
- Available specialists for statistical analysis
- Harmonization of technical support
- Implementing the questionnaire in time slots
- Subjectivity of individual reports
- Fluctuations in the studied sample
- Respondents mainly from the technical field

- Research objectives:

1. Identify strategies for effective exam preparation and make recommendations for teaching-learning-assessment methodology in foreign language education.

2. Harmonising the level of foreign language in high school and in faculty with the difficulty of the foreign language exams.

3. Developing a framework of analysis and improvement for the national Baccalaureate exam in Romania, by synchronizing the sample of foreign language requirements with inter-national forms of testing & certification of idiom skills [11] and with the Europass Language Passport standards in terms of its current use in our secondary and higher education.



Fig.2. Academic, Professional & General English levels, with their corresponding testing framework [9]

Common European Framework (Council of Europe)	A1 (Breakthrough)	A2 (Waystage)	B1 (Threshold)	B2 (Vantage)	C1 (Effective Operational Proficiency)	C2 (Mastery)
Escuela Oficial de Idiomas (Spain)		Nivel Básico 2*	Nivel Intermedio 3*	Nivel Avanzado 5*	C1 Ciclo superior	
ESOL (English for Speakers of Other Languages – University of Cambridge)		KET (Key English Test)	PET (Preliminary English Test)	FCE (First Certificate in English)	CAE (Certificate in Advanced English)	CPE (Certificate of Proficiency in English)
IELTS (International English Language Testing System - British Council)		IELTS 3.0	IELTS 3.5 - 4.5	IELTS 5.0 - 6.0	IELTS 6.5 - 7.0	IELTS 7.5+
TOEFL (Test of English as a Foreign Language - Internet Based Test)		TOEFL iBT 38-56	TOEFL iBT 57-86	TOEFL iBT 87-109	TOEFL iBT 110-120	
TOEIC (Test of English for International Communication)		10-549	550-755	756-879	880-973	974-990
ALTE (Association of Language Testers in Europe)	0 Elementary	1 Pre-Intermediate	2 Intermediate	3 Upper-Intermediate	4 Advanced	5 Upper advanced
BULATS (Business Language Testing System)		21-39	40-50 51-59	60-67 68-74	75-79 80-84 85-89	90-93 94+

Fig.3. CEFR, The Council of Europe [10]

4. Quantification of Baccalaureate relevance in relation to university studies and careers.

- Content analysis of foreign language curricula in secondary & tertiary education.
- Increase flexibility and adaptability to meet contemporary requirements in business and

technical dialogues

- Stimulate the evolution of individual professional competence and efficiency by using two interrelated instruments: foreign languages and computers.

- Outline criteria for matching qualifications recognition, ensuring graduates' free movement on internship and work platforms.

5. Presentation of optimizing perspectives drawn from the empirical research

- Improve Baccaalaureate quality (reconsidering objectives, content and assessment methods for communicative competence in a foreign idiom)

- Finding solutions for meaningful practice in all communication skills in the foreign idiom.

6. Identifying additional relevant suggestions respondents found in this debate:

- Facilitating exchanges of pupils and students in order to free mentalities compatible with the global education market characterized by competition for students and resources

- Motivate graduates for further education.

## RESULTS AND DISCUSSIONS

Here follows the analysed data for the learning styles of students focused on English acquisition and communication competence progress (Fig. 4).

When commenting upon this, we must point out that, sadly, 67% of the respondents do not learn from notes they take during class-work, which means that they:

- do not actively participate in the ongoing teaching and learning with all attention focused

- do not trust their own way of capturing and recording useful data from that presentation

- the content presented in the classroom is not perceived as useful / motivating / relevant / logical/ clear or captivating

- immaturity: the attention focus fades fast

- numerous students in groups: negative impact on discipline and on opportunities of relevant participation with personal views.

- narrowly practised intellectual work habits

- superficial in their personal approaches and data processing, just like the 'models' around

- disinterest in school & values promoted by

it

- availability of alternative information sources, which are richer & rigorously systematic

- some take notes only in the subjects of perspective interest, or those verified by tests

- not knowing the exact spelling, the student avoids writing in the foreign language

- limited personal lexis reduces understanding of concepts in the presented lecture

- in concentric teaching of subjects, if certain steps were missed, whatever follows cannot be understood, so it becomes pointless to take notes, and the student gives up

- rebellious teenager spirit

- overestimating their own intellectual potential

Although three-quarters of those surveyed per-form additional documentation and research from other sources (the Internet, dictionaries, atlases, specialized studies, references indicated by teachers, tutors, parents, or peers), only 32% use fast reading techniques to identify the basic idea or the significant details.

It takes constant linguistic practice and exercise to successfully use clues from the context: text markers/logical connectors, word order, pre-fixes, suffixes, intonation. Only 18% of those questioned use such clues, the rest being trapped in the vicious circle of '*I do not use it be-cause I do not know how / do not know how because I do not use it*'.

One third of the respondents summarize all available sources but three-quarters do not solve tasks of the same type to form a habit which will increase fluency in expression. Students consistently and constantly underestimate the contribution of personal effort to learning, and they often mistake it by innate intelligence and good memory.

43% use imagination and personal memories in data associations for easily retaining them, but mnemonic strategies (pictures, rhymes, and links) that reduce effort are used only by 14%. Only 19% of the subjects questioned actively restructure and integrate new information with previously acquired data.

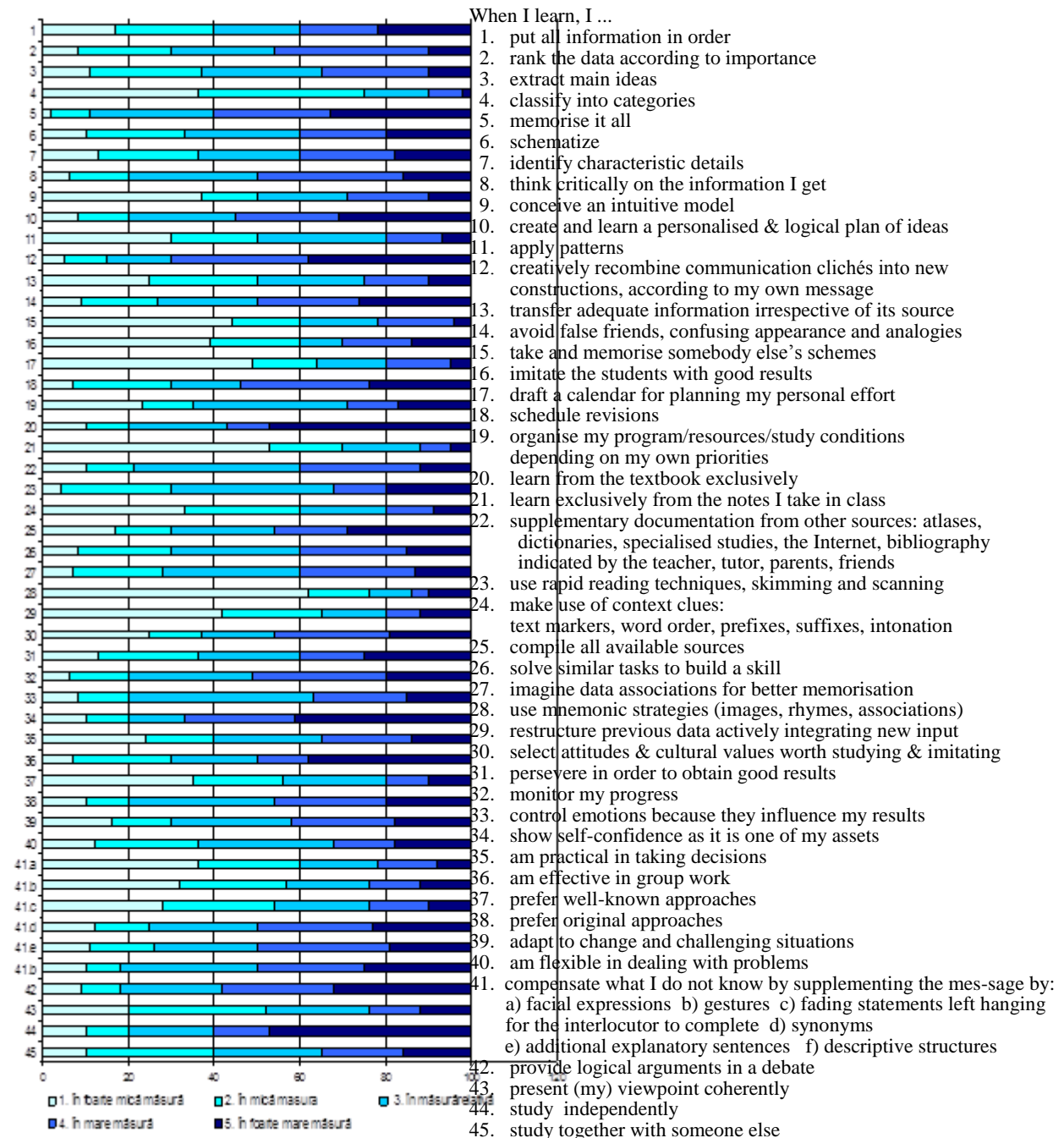

Fig.4. Study skills for foreign idioms

Half of them select which attitudes and cultural values they want to study and imitate, thus beginning to show increased discernment, with reference to career goals and the EU context. Increased self confidence is present in 41%, but only 34% display common sense and practical decision-making processes. It is useful to know that the teaching strategies of teamwork and project work collaboration led to the result that half of those questioned state they yield better results when working in groups.

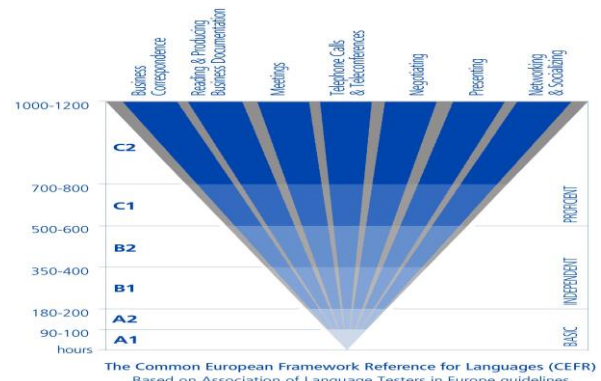

Fig. 5. ALTE levels corresponding to business uses [12]

This requires significant and almost equal contributions to the global effort, honesty in de-limiting their own ideas from others', fair play in attitude and in awarding credit for somebody else's input, elegant conduct and constructive criticism; let us hope that all these traits will eventually overcome the tense and counter-productive individualistic working atmosphere.

There is greater openness towards original approaches and intellectual courage in taking risks: only 17% prefer the well known paths. An invaluable asset of current generations is adaptability: 43% to a large and very large extent, with 28% stating that they are relatively adaptable to change and flexible in addressing problems; it seems that students got used to living in a world of negotiations quite fast.

When they fail to express the desired message, the unknown language issues are preferably compensated by approximation: mimicry 6%, gestures 9%, sentences left suspended to be completed by the interlocutor 11%, and synonyms, explanatory sentences as well as descriptive structures – almost half. In proportion of 82%, the students cannot learn or expose know-ledge outside logical argumentation frame-works. Coherent presentation is managed by merely 23%. More than 3/4 of the respondents study independently; 26% learn together with someone else, either for logical, emotional, or motivational support, or for effective time management.

Students' learning styles [15] should allow a high level of autonomy in knowledge transfer [16] and in skills use for communicating practical technical approaches; to articulate an integrated ensemble of skills, the teaching must provide interactive and participative contexts, where emphasis should be placed on flexible and dynamic learning, based on cooperation and research, on exercising critical thinking, on independent acts & stimulated creativity, more useful than mere theory from the perspective of active inclusion on the job market. Textbooks are a modern study partner who teaches the student how to learn. Auxiliary materials for further education and better learning outcomes are

prioritised as follows:

The strategy shifts the focus from *knowing* to *using*, thus cultivating specialist skills (knowledge, abilities, attitudes, values) to grant the students' personality harmonious development. Effective teaching & learning & assessment will unfold when learners prove the acquisition of certain values manifested in peer interaction according to the learners' degree of participation in the training.

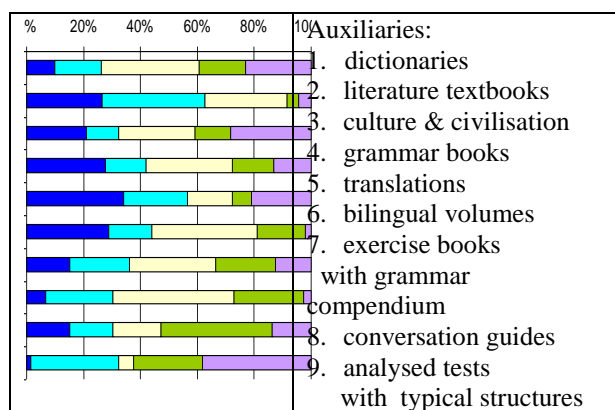

Fig.6. Preference for auxiliary materials in the study of foreign languages

The foreign idiom curriculum for the Baccalaureate test contains enough elements of education for values, democracy and multiculturalism, seemingly compensating for other subjects (civics). Moreover, elements of unprejudiced education increase knowledge of language, history, culture and civilization.

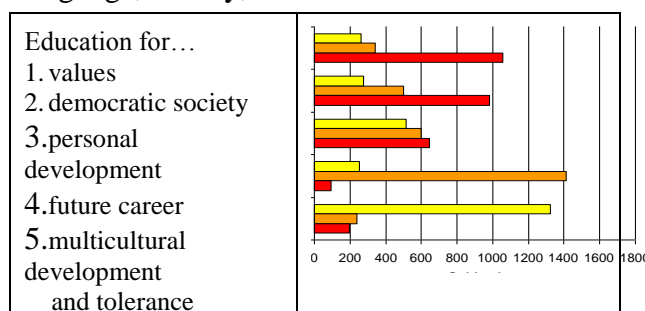

Fig.7. Targeted educational areas

Active integration of foreign language skills developed in formal and informal areas, lead to significant increase in communication quality and professional competence at the workplace.

In order to use new methods, to enforce new curricula, and to actively teach on a communicative basis, professors need to re-train them-selves according to the challenges



nowadays. Active-participatory didactics, alongside with training and retraining of teachers in this regard will lead to generations of graduates able to meet current professional shifts and evolve by lifelong learning strategies. [22]

The English exam in the Bacalaureate stands proof to the decrease of testing literature, culture, and civilization, at the same time focusing more on the components of grammar in communication and text comment with statement and argumentation of own viewpoint. Since 1991, the foreign language test in the national Bacalaureate exam has gone through various simplifications, modernizations, insertions of practical use elements, gradually giving up the areas of literature, culture & civilization; subsequently, the weight and the difficulty of the grammar tested decreased as well. The gain is fluency, but the loss is of substance & quality.



Fig.8. Changes in the Bacalaureate English exam over a decade: 1999-2010

---→ the literature, culture, and civilisation component  
 ---→ the grammar in communication component  
 ---→ text comment and own viewpoint argumentation

The reference point [23] in tertiary education English communication is the reality of the future employment/the next specialist academic program that the graduate will choose.

The work is no longer centred on the teacher, but the on student, who is actively interacting with peers, eliminating passive absorption of data; teachers' attitude towards the didactic process is altered to streamline the implementation of large-scale work in pairs, teams, role play, projects, by setting up portfolios in co-operative learning and study by discovery.

The pragmatic motivation will play a more important role in language acquisition, hence

the customizing of the student group and of the mix of resources and teaching techniques Correction can be difficult for students learning under the influence of the Romanian language, who adopt inter-language mistakes from their media exposure. Such errors originate in the status of lingua franca English holds nowadays: it is studied by many speakers who unwittingly preserve their own native language features (accent, phrasing, word order, gram-mar patterns, and idiomatic clichés); it all gene-rates new language versions, generically called Englishes [6]; pop culture globalization facilitates the process. The mistakes stem from inter language which is the transfer of language rules, patterns and sub-systems of the mother tongue into the target foreign language, sometimes with wrong transfer of learning skills. In addition to this, language acquisition strategies may be applied to inappropriate content, or unjustified over-generalization of communication skills, address, semantic & grammatical mixes with the mother tongue may occur.

A new balance emerges between inductive and deductive learning in foreign languages.

The curriculum is focused on compiling an inventory of communication functions

Extra-curricular activities will increasingly complement classroom learning

There is increased correlation between the content studied and students' maturity

		Language courses 6 months	Skill workshops 2 months	Exam preparation 12 months
CLT course levels	C2			
	C1		Business Workshops:	BEC Higher
	B2	CEF B2/1 CEF B2/2	Telephoning Meetings Presentations Negotiations	BEC Vantage
	B1	CEF B1/1 CEF B1/2		BEC Preliminary
	A2	CEF A2		
	A1	CEF A1		
		Classroom instruction Online-Tutoring Self-paced training	Workshops Online-Tutoring Self-paced training	Classroom instruction Online-Tutoring Self-paced training
		Method		

Fig.9. Sample business English study plan for young adults [2]

The curriculum must also include courses on information processing, study skills, revision

planning and schedule management, as well as self-management. Here is such a sample, focusing on business English study for young adults.

Internet used in self-access independent study Students can opt for different strategies from a range offered by manuals & teachers acknowledging that there are several correct ways to convey the same message, expressed in a flexible manner.

Current themes such as globalization will be integrated into textbooks, and tests quantifying skills and problem solving abilities will be part of tertiary education, via CLIL [5] or traditional systems, with direct impact on the psychosocial adaptation and on the motivation that directs and facilitates academic performance.

## CONCLUSIONS

The present research was motivated by the need to modernize the acquisition process of wide circulation modern languages, such as English, in the implementation of the EU standards into Romanian education, for promoting linguistic diversity & proficiently trained speakers. Consistent with EU membership, our system must be compatible with the rules of CEFR – the Common European Framework of Reference for Languages, in the fields of learning, teaching and assessment.

Hence it becomes imperative to formally connect modern language learning offers in Romania with the labor market dynamics in line with the strategic objectives in the European Pro-gram for Vocational Education & Training Horizon 2010-2020. The design, organization and evaluation of idiom acquisition process are per-formed by integrating rational ways of self-reflection with modern assessment tools.

The introduction of Europass Language Passports in upper secondary and tertiary education facilitates acknowledging & labelling language skills in line with EU standards. Implementing the Language Passport streamlines communication skills assessment and optimizes certification methodologies; achieving the required skill

levels will be done in close connection with the professional environments and the job market.

Using Language Passports in higher education and adult education is motivating and effective, yielding a widely accepted benchmark for the selection of qualified staff, according to the European Language Portfolio.

In a nutshell, this collaborative research clearly possesses practical implications which will be subsequently explored by identifying additional solutions to increase the use of effective foreign language communication skills by prioritising good practice able to improve performance.

The structural and organisational reforms in the education systems have been implemented with a view to reducing early school-leaving rates and increasing access to the labour market.

## REFERENCES

- [1]Albou, P., 1988, Le Questionnaires psychologiques, P.U.F., Paris
- [2]Babbie, E., 1992, The Practice of Social Research, Free Press, New York
- [3]Bauer, R., 1996, Social Indicators, M.I.T. Press, Boston
- [4]Bell, J., 2002, Learning from research: Getting more from the data, Open University Press
- [5]Berthier, I., 2008, Le Sondage d'opinion Librairies Techniques Paris
- [6]Bryman, A., 1998, Quantity and Quality in Social Research, Hyman
- [7]Burgess, R., 1993, Research Methods, Nelson, London
- [8]Converse, J, Presser, S, 1996, Survey Questions, Handcrafting the Standardised Questionnaire, SAGE Publications, London
- [9]Cohen, M., Manion, L., Morrison, K., 2000, Research Methods in Education, Routledge
- [10]Gall, D., Gall, J., Borg, R., 2007, Educational Research: an Introduction, Pearson Education Boston, pp. 40-67
- [11]Gay, L., Mills, G.E., Airasian, P., 2006, Educational research: Competence for Analysis and Application, Pearson Education, Boston
- [12]Grix, J., 2004, Foundations of research, Basingstoke Palgrave, Macmillan
- [13]Fitz-Gibbon C., 1996, Monitoring Education: Indicators, Quality & Effectiveness, Cassell Publishing, London
- [14]Hammersley, M., 1993, Social Research, Philosophy, Politics and Practice, Sage Publications,



London

[15]Hammersley, M, 1993, What is Social Research?  
The Open University

[16]Hargreaves, A, Earl, L., 1996, Schooling for  
Change, Falmer Press, New York

[17]Javeau, C., 1971, L'Enquête par questionnaire,  
Editions de l'Université de Bruxelles, Bruxelles

[18]Johnson, B., Christensen, L., 2004, Educational  
Research: Quantitative, Qualitative, and Mixed  
Approaches, Pearson Education, Boston

[19]Krathwohl, D., 1998, Methods of Educational &  
Social Science Research. An Integrated Approach,  
Waveland Press, IL, pp. 649-677

[20]McMillan, J.H, 1992, Educational Research.  
Fundamentals for the Consumer, Harper Collins, New  
York

[21]Marczyk, G., DeMatteo, G., Festinger D., 2005,  
Essentials of Research Design & Methodology, Wiley  
& Sons

[22]Oppenheim, I., 1992, Questionnaire Design,  
Interviews & Attitude Measurement, Pinter Publishers,  
London

[23]Seadlack, G., Stanley, J., 1992, Social Research –  
Theory and Methods, Allyn & Bacon, Boston

[24]Summers, J., 1992, Attitude Measurement, Rand  
McNally, Chicago

[25]Wilson, N., 1994, Questionnaire Design: Practical  
Introduction, University of Ulster Press, Newton Abbey



## ASPECTS OF EMPLOYMENT IN AGRICULTURE IN THE MAIN DEVELOPMENT REGIONS OF ROMANIA

Reta CONDEI, Agatha POPESCU, Aurelia BĂLAN, Valentina TUDOR

University of Agricultural Sciences and Veterinary Medicine Bucharest, 59 Marasti, District 1, 11464, Bucharest, Romania, Phone/Fax: 00 40 744 6474 10, Emails: r\_condei@yahoo.com, agatha\_popescu@yahoo.com, balanaureliav@yahoo.com, valentina\_tudor@yahoo.com

*Corresponding author:* r\_condei@yahoo.com

### *Abstract*

*Agriculture is a sector of primary importance in Romania, both through its contribution to the economy and the share of employment. Its continuous development and improvement and the countryside must be designed and analyzed under three main aspects, namely agriculture, food and environment. The current analysis takes into account the state of Romanian agriculture today, but also economic and human potential of rural areas in the main areas of development, and their evolution in 2008-2013. The rural space in Romania is characterized by poor economic diversification and a major dependence on agricultural activities, which results in obtaining low incomes for farmers. The rural labour force should be directed to other activities, particularly in services, based on a correct and permanent information, human resource awareness and training. The rural employment strategies include measures to improve the quality of human resources to facilitate access to non-agricultural employment in connection with labour market needs.*

**Key words:** agriculture, employment strategies, family farms, human resources, population, regions, rural areas, rural development

### INTRODUCTION

Agricultural development should be seen and analyzed from space and functions of the rural economy, the need for their development, taking into account:

- Ensuring food security and safety by providing full domestic demand for improved quality food and a surplus to domestic food consumption, available for export;
- Ensuring long-term sustainable ecological balance of the countryside by investing in infrastructure works and equipment protection planning;
- Preservation and protection of renewable natural resources (soil, water, air, biodiversity) and sustainable use of natural resources, agriculture, primarily soil, biodiversity conservation, implementation of policies to mitigate the effects of climate change;
- Consolidation of farms, upgrading technology and overall improvement of farmers' activities;
- Stimulating the formation of private-commercial European type family farms by

gradual reduction in subsistence farms; [4]

- Balanced territorial development of rural economy agriculture, expansion of SMEs and rural non-agricultural food and increasing employment of rural population through employment and stability in rural areas, mainly rural population of young workers;
- Restriction of disadvantaged rural areas and rural poverty;
- Harmonization of national education and scientific research with the European one and ensuring its sustainable partnership with Romanian food system [2, 3, 13].

The necessity to develop a modern and efficient agriculture at national level is determined by:

- requirement to ensure national food security and ensuring food safety of the Romanian population;
- natural resources, human and material Romanian agriculture;
- ecological suitability of Romania agricultural resources to provide high quality food products on the domestic and international market.

To ensure national food security Romanian

agriculture should follow:

- increasing agricultural yields per unit area and livestock;
- increase in plant and animal production;
- increase in processed food production;
- increasing the rate of absorption of EU funds.

The greatest chance of Romania on agricultural development is rational and optimal allocation of capital investment in rural infrastructure, farm modernization, expansion of storage-processing enterprises of food products and increase operating capital, both from own sources and of bank loans [5, 6]. Analyzing the situation of agriculture and rural areas and their evolution in 2008-2013 on the strengthening Romania's agricultural structures (nationally and by region), we have developed this material taking into account the economic, and human potential in agriculture and rural areas, but also from the integration requirement of the Romanian agriculture in the European food area [1, 2, 15, 16].

## MATERIALS AND METHODS

Defining the place of agriculture in the national economy can be achieved through a set of relevant indices, related to resources and inputs, on the one hand and on the other hand to the results.

The relative instability of labour resources has to be taken into account when the medium and long term agricultural policy is set up. Also, the shaping and implementation of the agrarian structures (farms and production) should take into consideration the current situation and, especially, the demographic perspectives of resources employment in the rural areas and agriculture in terms of employment, the social status and the existing disparities in the territory by region [8].

The farming population means the population who has an income from agricultural activities, either as technicians or farmers or authorized independent farmers, while the population of subsistence agriculture means unpaid family workers in household production for own consumption. It was found

that the employment situation in rural areas is more difficult than in the urban areas and in the agricultural activities.

The paper is based on the statistical data provided by the National institute of Statistics for the period 2008-2013, and analyzed the following specific indicators: employment at national level and by development region in absolute figures and the share of each region, employment in agriculture by development region in absolute figures and the share of each region, employment structure by region, professional status and age group both at the national level and in agriculture.

The most used methods were the fixed basis index, and comparison method.

## RESULTS AND DISCUSSIONS

### Human resources in the national and rural development areas

**Current situation and trends.** Rural areas have a substantial growth potential and a vital social role. In 2012, Eurostat data showed that 45.5% of the total population lives in the rural areas. [8] In the period under review, In Romania, the employment fell by 232,000 people (2011), representing a decrease by 2.5% compared to 2008, while the employment in rural areas decreased by 202,000 people (2011) representing a decrease of 4.7%. [9]

The demographic decline is associated with the continuous degradation of the age structure caused by the aging of the population, meaning that in the future, the younger age groups will be reduced, while the elderly groups will increase. The demographic aging is more pronounced in the rural space than in the urban areas. [3,5 6,14]

The workforce reduction in the national economy by 381,500 persons actively employed in 2008-2013, agriculture contributed 27,300 people (2013). Across the countryside, rural population decline in 2008-2013 ranged between 201,908 and 56,822 persons representing a reduction of 2 to 4.7%. [7]

During the period under review, the farming population is 27.5% of total employment, and decreased by -5.2% in 2012 compared to 2008, while employment in the country

declined by 2.5 (Table 1).

The reduction in the number of rural inhabitants was due to several demographic, economic and social factors. In early 2008,

the share of population of 65 years and over in rural areas was 8.15% of the total population and fell to 7.41% in 2013.

Table 1. Dynamics of employment in agriculture and its share in Romania's employment, 2008-2013 (2008=100%)

Indicator	2008		2009		2010		2011		2012		2013	
	Thou Pers.	%	Thou Pers.	%	Thou Pers.	%	Thou Pers.	%	Thou Pers.	%	Thou Pers.	%
Employed persons, of which:	8,747	100	8,410.7	96.1	8,371.3	95.7	8,365.5	95.6	8,569.6	97.9	8,530.6	97.5
Employed in agriculture	2,407	100	2,410.7	100.1	2,439.9	101.2	2,442.0	100.1	2,510.0	102.8	2,380.1	94.8
Share of employed persons in agriculture in national employment (%)	-	27.5	-	28.6	-	29.1	-	29.1	-	29.2	-	27.9

Source: Own calculations based on data from Romanian Statistical Yearbook, 2008-2013 series, INS, Bucharest [10]

In terms of population, gender structure of the rural population is kept within limits which allow the normal course of specific processes socially and economically. This distribution should be one of the important factors of realization of human resource development strategies.

In the main development areas of Romania, the largest share of population employed belonged to Bucharest-Ilfov and North-East regions (each over 14%), followed by the North-West and South Muntenia regions with a share of over 13% each (Table 2).

Table 2. Share of Romania's employment by development regions, 2008-2013 (%)

Development regions	2008	2009	2010	2011	2012	2013
<b>Total employment at national level, of which:</b>	100	100	100	100	100	100
North-West region	13.6	13.7	13.8	13.8	13.8	13.9
Central region	11.9	11.9	11.9	12.0	12.1	12.2
North-East region	14.2	14.3	14.4	14.2	14.3	14.1
South-East region	12.0	12.0	11.9	11.8	11.8	11.8
South-Muntenia region	13.7	13.8	13.8	13.8	13.8	13.7
Bucharest-Ilfov region	14.6	14.5	14.5	14.6	14.6	14.7
South-West Oltenia region	9.9	9.9	9.9	9.9	9.8	9.7
West region	9.8	9.7	9.7	9.7	9.7	9.7

Source: Own calculations based on data from Romanian Statistical Yearbook, 2008-2013 series, INS, Bucharest [10]

Employment in agriculture in the main development region shows that five of the eight development regions have between 13-20% share each, altogether with over 80% of human resource potential (Table 3).

The number of the Romanian agricultural family holdings, as registered by APIA, totalized 1.1 million, divided by size classes are presented in Table 4.

A number of total of 12,034 agricultural

companies, societies and associations with legal personality, representing 1.07 % of the total number of holdings own 5, 113,458 ha, that is 52.11 % of the total agricultural land.

In this companies there are working many skilled workers in agricultural occupations, unskilled workers and technical specialists, economists and managers with higher education. [1]

Table 3. The share of Romania's employment in agriculture by development region, 2008-2013 (%)

Development regions	2008	2009	2010	2011	2012	2013
<b>Total employment in agriculture, of which:</b>	100	100	100	100	100	100
North-West region	15.07	15.06	14.91	15.04	15.03	15.04
Central region	10.03	10.07	9.92	10.01	10.01	10.01
North-East region	20.32	20.29	20.53	20.29	20.25	20.25
South-East region	13.50	13.53	13.50	13.62	13.58	13.60
South-Muntenia region	17.62	17.62	17.55	17.59	17.64	17.60
Bucharest-Ilfov region	1.55	1.49	1.50	1.51	1.51	1.53
South-West Oltenia region	13.57	13.59	13.73	13.60	13.60	13.58
West region	8.36	8.31	8.33	8.32	8.35	8.35

Source: Own calculations based on data from Romanian Statistical Yearbook, 2008-2013 series, INS, Bucharest [10].

Table 4. Romania's farm structure by holding type in 2010

Exploitation Area (ha)	Number of exploitations	%	%	Area (ha)	%	%
<b>Family exploitations (FE)</b>						
1-5	900,633	80.46		2,199,166	22.48	
5-10	145,963	13.04		963,060	10.03	
10-50	54,365	4.86		1,055,972	10.77	
50-100	6,325	0.57		451,522	4.61	
<b>1. Total FE</b>	<b>1,107,286</b>	<b>98.93</b>		<b>28.72</b>	<b>4,669,720</b>	
<b>Commercial exploitations (CE)</b>						
100-500	9,315	0.83		2,087,244	21.33	
500-1000	1,808	0.16		1,240,321	12.57	
1000-5000	882	0.08		1,457,029	14.86	
5000-10000	20	0.00		168,219	1.51	
>10000	9	0.00		180,645	1.84	
<b>2. Total CE</b>	<b>12,034</b>	<b>1.07</b>	<b>0.31</b>	<b>5,113,458</b>	<b>52.11</b>	<b>34.82</b>
<b>Unfunded subsistence exploitations (UE)</b>						
<b>3. Total UE</b>	<b>2,736,680</b>	<b>x</b>	<b>70.97</b>	<b>4,901,822</b>	<b>x</b>	<b>33.38</b>
<b>TOTAL</b>	<b>3,856,000</b>	<b>x</b>	<b>100.00</b>	<b>14,685,000</b>	<b>x</b>	<b>100.00</b>

Source: Data provided by APIA, 2010

In addition to the number of 1.1 million farmers, 2.74 million rural inhabitants are practicing agriculture in part-time subsistence farms unfunded by APIA, but holding 1/3 of the country's usable agricultural area (4.9 million ha, meaning 33.4%).

Of the 1.1 million family farms, the largest share is held by those with an area of up to 5 hectares, representing 80.46%, followed by the farmers owning between 5-10 hectares, accounting for 13 %. In terms of human resource, rural development strategy is based on the distribution of farmers - heads of exploitations by age and, especially, the share of young farmers nationwide. [7] (Table 5).

The farmers distribution by age group at the national level highlighted the following aspects:

- The largest share is held by farmers over the age of 70 years (31.9% of farmers), followed by the age group between 61-70 years representing 26.5% of all farmers.
- Farmers aged 31-60 years represent 40.6%, while those aged under 30 have a share of 1% of all farmers.

The high share of farmers excessive elderly (over 60 years and especially over 70 years), is a serious problem for the future of their holdings.

Table 5. Distribution of farmers by age

Age	Years	Under 30 years	Between 31-40 years	Between 41-50 years	Between 51-60 years	Between 61-70 years	Over 70 years	Total farmers
Number of farmers	Thousands pers.	10.2	74.7	141.3	231.8	292.6	351.4	1,101.7
	%	1	6.8	12.8	21.0	26.5	31.9	100
The average farm area	ha	9.1	7.0	6.4	5.0	4.0	3.2	4.5

Source: Data processed by APIA, 2010

The fact that almost 58.4% (i.e.644,000 farmers) are older than 60 years, holding in exploitation 2.31 million ha of agricultural land (over 25% of the country's arable land) is one of the major problems of human resources strategy in rural areas.

The young farmers aged under 40 represent about 8% of all farmers, and as a result, it is necessary to increase their number because they should be the core of human resources in rural areas in the future.

Agriculture is the backbone of the rural economy, but non-agricultural activities and sources generated by them are becoming increasingly important for households in rural areas.

The development of the agricultural sector is a key factor for increasing the employability of labour and income.

The employment rate of people aged 20-64

years is 63.3% by 6.7 % lower compared to the national target of 70% set for 2020.

The rural population employment rate is 63.7% compared with the urban population which recorded a 62.2% occupancy rate. [3]

The main features of the employment in rural areas are the following ones:

- Dwindling national employment with 381,500 persons (i.e. 4.4%) compared to 2008;

- The concentration of population employed in agriculture. At national level, the agricultural sector benefits from 27.5 % to 29.2% of total employed persons.

- The structure of the employed population by employment status showed that the largest share in total employment is held by employees (59.82 - 56.28%), self-employed (26.27%) and family workers(15.57%) (Table 6).

Table 6. Structure of national employment and agricultural employment by professional status, 2008-2013 (%)

Specification	2008	2009	2010	2011	2012	2013
<b>Total employment at national level, of which:</b>	100	100	100	100	100	100
Employees	59.82	58.01	54.72	55.71	55.74	56.28
Employers	1.83	1.48	1.73	1.50	1.20	1.87
Self-employed	24.72	24.73	26.81	25.61	26.15	26.27
Family workers	13.62	15.75	16.72	17.16	16.90	15.57
<b>Total employment in agriculture, of which:</b>	100	100	100	100	100	100
Employees	4.30	4.40	3.89	4.01	4.19	4.54
Employers	0.14	0.10	0.05	0.06	0.07	0.22
Self-employed	50.04	47.37	46.01	43.07	44.42	45.06
Family workers	45.50	48.12	48.30	52.84	51.31	50.16

Source: Own calculations based on data from Romanian Statistical Yearbook, 2008-2013 series, INS, Bucharest [10]

- The structure of employment in agriculture of the country highlighted that the largest share belonged to the self-employed people (45-50%), and family workers.

- In agriculture employees have a share below 4.5%.

- The aging of the agricultural population.

The employment rate belonging to the age group 15-24 years is 30.5%, while the rate of those under 55-64 years age group is 52.6 %.

- The employment in agriculture is characterized by a high percentage of people aged over 65 years with more than the share of this age group nationally, which is 6%.

Table 7. The share of number of employees in agriculture by region, 2008-2013 (%)

Development regions	2008	2009	2010	2011	2012	2013
<b>Total employees in agriculture, of which:</b>	100	100	100	100	100	100
North-West region	9.18	8.68	9.24	9.16	8.65	9.30
Central region	12.17	12.04	11.14	11.44	12.58	11.95
North-East region	15.74	15.50	15.90	15.80	15.74	15.96
South-East region	15.97	17.72	16.50	17.11	16.55	17.37
South-Muntenia region	20.76	21.46	20.93	20.24	20.85	20.09
Bucharest-Ilfov region	4.86	4.13	4.72	4.84	4.53	4.56
South-West Oltenia region	7.87	8.56	8.55	8.45	7.95	7.92
West region	13.41	11.86	12.99	12.92	13.11	12.82

Source: Own calculations based on data from Romanian Statistical Yearbook, 2008-2013 series, INS, Bucharest [11].

- The scarcity of educational capital: the share of people employed in agriculture with a higher educational level is 3.4%, the average level of training persons was 50.2%, people with low education level was 46.4% . [8]

- The analysis of the number of employees in agriculture in the main development region shows the highest share of this category in the region South-Muntenia (over 20%) of all employees, followed by the South-East and North-East, each with a share more than 15%. (Table 7)

Employment of human resources in rural areas is characterized by the following trends:

-The national employment in the analyzed period is reduced by 2.1-4.4%, while the population employed in agriculture increased by 2.8% and represents 29.2% of the working population;

-The structural change of the active population - farmers aged under 30 years is only 1%, and those aged 31-50 years represent about 20% of farmers;

-The scarcity of educational level inhibits labour mobility;

-The slow modernization of rural employment;

-The mismatch between supply and demand for labor in rural areas.

The strategy includes measures to stop the rural population demographic phenomena, rebalancing the age structure, modernization of education and training of the rural population.

## CONCLUSIONS

The dependence of the rural population to subsistence agriculture is a weakness of the labour force in Romania, self-employment

being associated with subsistence rather than entrepreneurship in agriculture.

So, the number of self-employed people reached 2.1 million (25 % of total employment). [9]

Romania also faces a low level of labour employed in non-agricultural activities in rural areas. The decreased number of people employed nationally 381,500 people, of which in the rural areas 202,000 people is a major shift of the occupational structure of employment. Almost the whole lost population employed in agriculture had the employment status of self-employed (including unpaid family worker).

-The tendency to reduce non-wage employment was accompanied by a decrease in the number of employees at national level by 698,000 people (in 2011 compared to 2008), which represented a 14% decrease. In agriculture the number of employees is in average 2.1-2.3% of employees nationally and suffered a decrease by 8.7% in 2010 compared to 2008.

As regards the structure of employment by professional status in 2013, 56.28% of the employed persons had the employed status (59.82% in 2008), 26.27% self-employed, and a member of an agricultural or a cooperative (24.72% in 2008), 15.57% unpaid family worker (13.62% in 2008) and 1.87% employer (1.83% in 2008);

The directions of human resources employment in the rural areas are focused on: modernization of education and training of the rural population, modernization of agriculture by implementing technological innovation, and scientific management, promoting



occupational mobility of the labour force in the rural areas in order to focus on its agricultural and non-agricultural occupational fields, promoting rural entrepreneurship and providing support services for initiating and fostering employability non-agricultural business in the rural areas.

[15]Socio-economic rural development perspective  
[16]Stoicescu, A., Alecu, I. N., 2012, Human resources development of the rural area-As a rural development component in the Bucharest-Ilfov region of Romania. Scientific Papers Series "Management, Economic Engineering in Agriculture and rural development", Vol. 12(3): 175-178.

## REFERENCES

- [1]Agrifood strategy Romania  
[2]Ciolos, D., Luca, L., Giurca, D., 2010, 20 years looking for consistency in the agricultural policies of Romania, in vol. I, coord: Murea, R, Boari, V, Vlas, N, publisher European Institute, Iași  
[3]Condei Reta, Stefan Ecaterina, 2011, Elaborating human resources and development programmes-Basic requirement of the organisation's economic efficiency, Scientific Papers Series Management, Economic Engineering in Agriculture and Rural Development, Vol.11(2):30-33  
[4]EUROSTAT, electronic database  
[5]Iorga Adina, Toma Elena, Dobre Carina, Muscanescu Alexandra, 2014, Rural labor force size and structure analysis, Scientific Papers Series Management, Economic Engineering in Agriculture and Rural Development, Vol. 14(2):169-173  
[6]Manescu Camelia, Mateoc Teodor, Mateoc-Sirb Nicoleta, 2014, Studies concerning the development level of agriculture in Romania, Scientific Papers Series Management, Economic Engineering in Agriculture and Rural Development, Vol. 14(1):197-203  
[7] National Strategic Rural Framework 2014-2020  
[8]National Strategy for sustainable development  
[9]National Strategy for employment of labour  
[10]National Institute of Statistics, Database TEMPO Online  
[11]National Institute of Statistics, Romanian Statistical Yearbook series, 2009-2014  
[12]Oțiman, P.I., 2012, Agrarian structure of Romania, a large (and unresolved) social and economic problems of the country, in "Agricultural Economics and Rural Development", Year IX, No.1, Publisher of Romanian Academy, Bucharest.  
[13]Oțiman Păun Ion, Toderoiu Filon, Alexandri Cecilia, Florian Violeta, Gavrilăscu Camelia, Ionel Iuliana, Sima Elena, Tudor Monica Mihaela, 2014, Sustainable Development Strategy for the Agri-food Sector and Rural Area – Horizon 2030, Procedia Economics and Finance, Volume 8, 2014, Pages 510–517, 1st International Conference 'Economic Scientific Research - Theoretical, Empirical and Practical Approaches', ESPERA 2013  
[14]Popescu Agatha, Grigoras Mircea Adrian, 2011, Research concerning rural versus urban population-Present and Prospect, Scientific Papers Series "Management, Economic Engineering in Agriculture and rural development", Vol. 11(2):151-156



## GENERAL ASPECTS CONCERNING THE CLIMATE OF THE OLTENIA REGION. CASE STUDY: THE OLT COUNTY

Dana Maria (OPREA) CONSTANTIN<sup>1</sup>, Elena COFAS<sup>2</sup>, Iuliana ZAHARIA<sup>2</sup>

<sup>1</sup>University of Bucharest, Faculty of Geography, Department of Meteorology and Hydrology, 1 Nicolae Bălcescu Blvd., 010041, District 1, Bucharest, Romania, Phone: +4021 314 3508, Fax: +4021 315 3074, Email: danamartines@yahoo.com

<sup>2</sup>University of Agricultural Sciences and Veterinary Medicine of Bucharest, Faculty of Management, Economical Engineering in Agriculture and Rural Development, Bucharest, Romania, 59 Mărăști Blvd., 011464, District 1, Phone: +4021 318 2564, Fax: +4021 318 2567 Email: cofasela@yahoo.com, iulia\_zaharia@yahoo.com

*Corresponding author:* cofasela@yahoo.com

### Abstract

*The analysis and interpretation of data on the agro-climatic resources of a cultivated area offer the possibility to characterize the degree of favorability for cultivated species depending on the climate and soil bid. Depending on the climate, soil and the agricultural species requirements, the agro-technical management system must be applied properly, so as to allow the improvement of agricultural productivity. The aim of this study is to assess the agro-climatic resources of the Oltenia region, for the period 1961–2008 and especially of the Olt County, in terms of thermic and precipitation resources for the period 1990–2013. The knowing of these conditions is required for choosing the cultivated product and the crop production interventions used for obtaining optimal economic crops.*

**Key words:** air temperature, precipitation, Oltenia, the Olt County

### INTRODUCTION

The climatic events of the last decades have drawn the attention of the experts upon a global climate warming trend.

The increase in intensity and frequency of the climatic extremes have produced damage in all the economic sectors, especially in the agricultural sector, which is closely related to the weather evolution. The impact of climate variability on the agricultural crops is quantified by the potential of the meteorological-related parameters, which provide favorable and/or unfavorable conditions, depending on the intensity, duration and way of the disturbances, and on the temporal variation and vulnerability of the plant species. The agricultural productions will be affected by this climatic variability, especially in the agricultural areas with high risk of drought and low potential for adaptation (Sandu I. et al, 2010). [11]

Based on the climatic studies, one can find out the characteristics of a natural region, thus ensuring an efficient use of the agro-climatic

potential of the region (Lungu M., 2013). [9]

This article will analyze the main meteorological elements: the air temperature and precipitations, thus highlighting the potential peculiarities of the thermic and hydric resources (Dumitrașcu M., 2006). [7]

The vital activity of the plants depends on the thermic conditions and precipitations (Săndoiu I., 2001) [12].

The agro-climatic analysis is made for the Olt County, in the period 1990–2013. It is also provided a short analysis of the agro-climatic potential of the historical region of Oltenia, for the period 1961–2000, which the Olt County is part of.

### MATERIALS AND METHODS

In developing these analyzes, there have been used agro-climatic data from representative agro-climatic stations for the Oltenia region, but especially the data from the Slatina and Caracal stations. The agro-climatic information processed by CMR Oltenia are also added. The processing of the statistical

data aimed to analyze the thermic regimes, the annual precipitations and to calculate the De Martonne aridity index. Furthermore, graphics and maps are added to these statistical methods.

## RESULTS AND DISCUSSIONS

**Oltenia** is the historical region in the south-western Romania, between the Olt river in the east, the Danube river in the south and west, and the Carpathians in the north (Figure 1). From the north to the south, it covers about  $1^{\circ} 55'$  latitude, and from west to east at  $2^{\circ} 53'$  longitude, with an area of 29015 km<sup>2</sup>, representing 12.2 % of the country surface (Marinică I., 2006). [10]

In terms of altitude, the relief descends from the north, from 2519 m – the Parângul Mare Peak, to the south, where the elevation is below 100 m, in the Danube Valley. The north of Oltenia is mountainous, being represented by the Retezat–Godeanu and the Parâng Mountains. At the foot of the Carpathians, there are the Oltenia Sub-Carpathians, the Mehedinți Plateau and the Severin Basin, continued by the Getic Piedmont (Plateau) and the Oltenia Plain, subunit of the Romanian Plain.

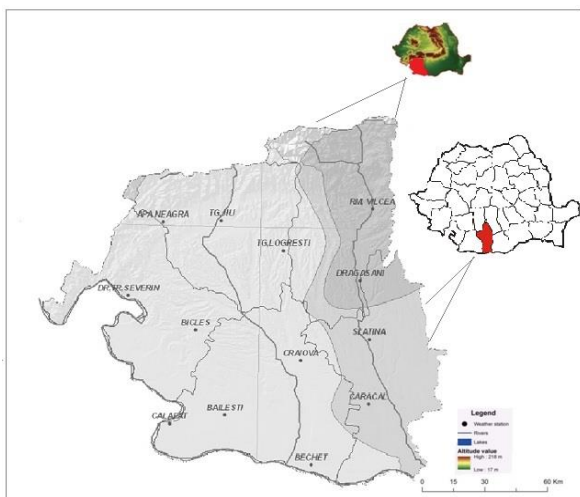

Fig.1. The geographical position of the Oltenia region and of the Olt County in Romania  
Source: own processing from [www.google.ro](http://www.google.ro)

From the administrative point of view, the Oltenia region includes the counties of Mehedinți, Gorj, Vâlcea, Dolj and Olt, plus small areas of the Caraș-Severin and Hunedoara counties.

**The Olt County** is located in the southern part of Romania, along the lower course of the Olt river, from where it takes the name, representing 19 % of the Oltenia region (Coteț P. et al., 1975). [6]

The relief of the Olt County overlaps the major units: the Getic Piedmont (Plateau) (33 %) in the north and the Romanian Plain (67 %) in the south (Iagăru et al., 2001). [8]

From the altitudinal point of view, the county is situated between 400 m in the north and 20 m in the south, in the Danube Valley.

The joint action of the radiative, dynamic, physical and geographical factors has generated climatic conditions which clearly identify Oltenia in Romania and of the Olt County in Oltenia.

Oltenia and thus, the Olt County belong to the temperate climate of transition, to the subsector with a transition climate from outside the Carpathian arch (Ciulache, 2002). [3]

In Oltenia, the meteorological station with the highest altitude, of 1548 m, is the Parâng station, while the lowest is Bechet, at 35.9 m. The most northern stations are Voineasa and Petroșani, the most western is Băile Herculane, while the most eastern stations are Caracal and Slatina (Fig.2).

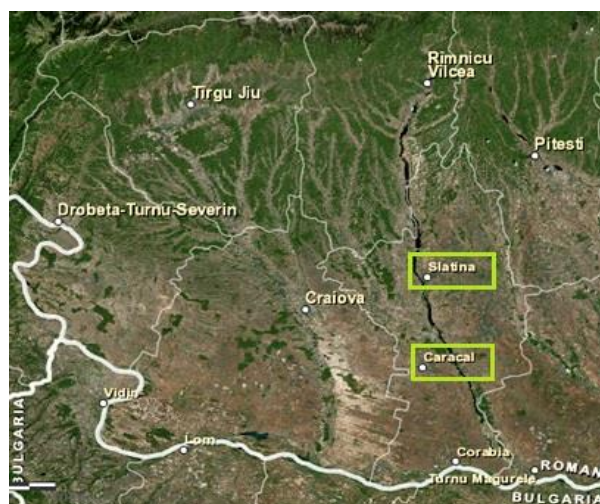

Fig. 2. The geographical position of the Slatina and Caracal meteorological stations in Oltenia  
Source: own processing from [www.arcgis.com](http://www.arcgis.com)

Oltenia, by its position in the country, is under the influence of the baric centers of action in the Mediterranean Sea, the Atlantic Ocean, the East-European Plain, the North Africa, the

Scandinavia Peninsula and even Greenland. Above Oltenia prevails, in descending order of frequency, the following air circulation types: southern, western and eastern (National Administration of Meteorology, ANM, 2008).

[1]

**The thermic regime of Oltenia** is characterized by an annual average temperature of 10.6 °C for the period 1961–2000 and 11.4 °C, for 2001–2008, being recorded a positive deviation of +0.8 °C. The position of the Carpathians and Sub-Carpathians is reflected in the direction of air masses penetration in Oltenia, so that the distribution of the annual average temperatures decrease from the west to the east and from the north to the south, being recorded 11.7 °C at Drobeta Turnu Severin, 10.9 °C at Craiova and 10.4 °C at Drăgășani. The highest average temperature values are recorded in the southern Oltenia, where there are the lowest altitudes. The 11 °C annual isotherm passes the north of Drobeta Turnu Severin, the south of Segarcea and in the east of this village is almost parallel to the isoline of 100 m altitude. In the period 1961–2008, the year 2007 was the warmest, the annual average temperature being 12.6 °C. The summer of 2007 was comparable to that of 1946, but with a higher persistence of the hot days ( $t_{max} \geq 35.0$  °C), so that it exceeded the absolute maximum temperature of July, by country, by 0.8 °C above the absolute maximum in 2000, being 44.3 °C at Calafat, on the 24th of July 2007 (Sandu et al., 2010).

[11]

Since 1961, there has been an increasing emphasis in the annual average temperatures across the whole country (Busuioc A. et al., 2003). [2]

**The precipitation regime of Oltenia** is characterized by an annual precipitations of 650.3 mm for the period 1961–2000 and of 709.5 mm for the period 2001–2008, registering a positive deviation of 59.2 mm. The first period is considered optimal, while the second one is a rainy period from climatological point of view (Sandu et al, 2010). [11]

In Oltenia, there are recorded two maximum of precipitations, the first in November–

December and the second in May– June. In the western part of Oltenia, the second maximum is close to the first one, while in the eastern part of the region it disappears. The cause is the atmospheric circulation with an eastern part, which brings cooler air masses and poorer precipitations than in the western half. For the period 1961–2000, the year 2005 was an excessively rainy year, being considered exceptionally, by scale, exceeding the years 1970, 1972, 1975 and 1991.

Due to its position, the eastern part of Oltenia, of the Olt County, is characterized by large thermic amplitudes caused by the continental air masses coming from the east and northeast, accompanied by storms in the winter and by intensive heating in the summer, determined by the continental tropical air masses coming from the south. As about precipitations, the Olt County records a disruption in the normal course of the annual quantities because of the emergence of a central portion, focused on the Olt River, at the confluence of the Olt river with the Olteț river, with precipitations below 500 mm (Coteț et al., 1975). [6]

In the last decades, this area has expanded to the west and north of the County, because of the deforestation along with the Olt Valley, of the hydro-electric dams and of the emergence of some turbulent air currents (Iagăru et al, 2001). [8]

**The thermic regime of the Olt County** is characterized by an annual average temperature of 11.4 °C at Slatina and 11.6 °C at Caracal, for the period 1990–2013.

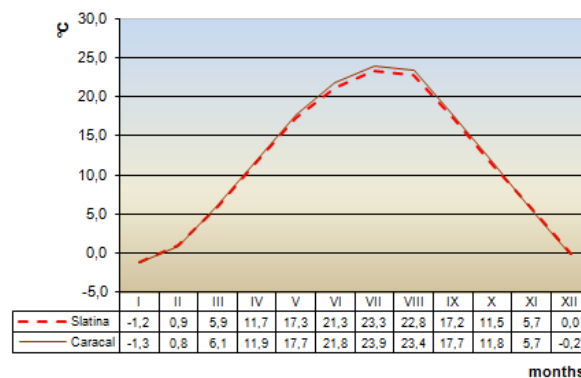

Fig.3. The annual regime of air temperature at the Slatina and Caracal stations, 1990–2013

Source: data processed after ANM

The Olt County is located between the annual isotherm of 11°C located almost parallel to the Danube and the one of 10 °C, situated at the north of the border with the neighboring counties of Vâlcea and Argeş.

During the year, except November, when the same temperature of 11.4 °C is registered, and February, when a higher temperature by 0.1 °C is registered for the Slatina meteorological station, all the other months present higher monthly average values by 0.1 °C to 0.6 °C, at the Caracal meteorological station (Fig. 3).

This is the consequence of the geographical position further inside of Caracal, in comparison to Slatina, which is located near the Olt Valley. The highest differences are from June to September.

**The precipitation regime of the Olt County**, like the thermic one, has the same continental influence, which is primarily in the form of rainfall, irregularly distributed across the county. The precipitations have a frontal and thermo-convective origin and sum up 589.4 mm at Slatina and 527.3 mm at Caracal, for the period 1990–2013. Generally, the precipitations are not sufficient for the autumn and spring crops, which thus require irrigations. The analysis of the monthly precipitations shows the increase in quantity from February to July and then a decrease until January, at both the meteorological stations (Fig. 4).

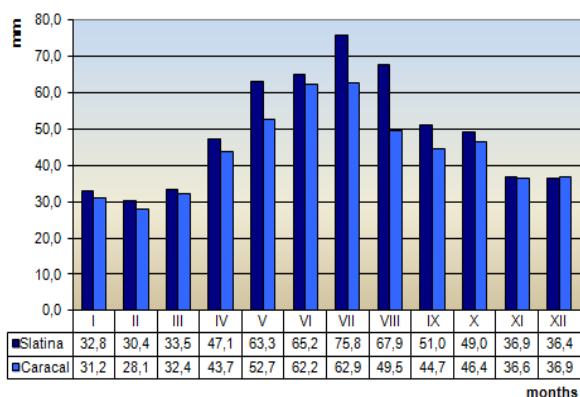

Fig. 4. The annual precipitations regime of the monthly average precipitations at the Slatina and Caracal stations, 1990–2013

Source: data processed after ANM

Most precipitations, 60–70%, fall in the warm half of the year (April to September), overlapping the vegetation period.

**The De Martonne aridity index** indicates the moisture or drought conditions for an area. The index has been calculated annually, based on the formula  $I_a = P/(T+10)$ , where P is the annual average amount of precipitation, T is the annual average temperature and 10 is the Celsius degrees value which is added to the denominator in order to produce positive results (Constantin et al., 2014). [5]

For the period 1990–2013, in the Olt County, the aridity index varies from 24.4 at Caracal to 27.5 at Slatina. According to the classification of this index, the Olt County belongs to the semi-humid climate, where the silvosteppe vegetation grows.

## CONCLUSIONS

The air temperature, along with the precipitations influence the processes of growth, development, photosynthesis, respiration and transpiration of plants. These processes occur at a specific temperature and precipitation amount specific to each species and to each vegetable crop (Cofas El. et al., 2014). [4]

Based on the analysis, it can be concluded that the Olt County indicates an emphasis of the continental character from the north to the south, with specific regional influences of the Danube and the Olt Valley. The analysis of the agro-climatic data (air temperature and precipitations) in the Oltenia region shows a variability from year to year, comparing to the optimal limits of each agricultural period, each growing season and crop year. To know these conditions is essential in order to choose the type of cultivated plants and for the crop production interventions which ensure, from economic point of view, optimal crops.

## REFERENCES

- [1]Administrația Națională de Meteorologie, 2008, Clima României, Editura Academiei Române, București.
- [2]Busuioc Aristița et al., 2003, Impactul potențial al schimbării climei în România, Editura Ars Docendi, București.
- [3]Ciulache, S., 2002, Meteorologie și climatologie, Editura Universitară, București.
- [4]Cofas Elena, Constantin (Oprea) Dana Maria,

Zaharia Iuliana, 2014, General aspects of the agro-climatologic potential in Muntenia Region, Scientific Papers Series Management, Economic Engineering in Agriculture and Rural Development, Vol.14 (2): 67-70.

[5]Constantin (Oprea) Dana Maria, Grigore Elena, 2014, The Assessment of the agro-climatic parameters and coefficients employed in the drought evaluation, Romanian Statistical Review, Supplement, no. 7, 25-31.

[6]Coteș, P., Urucu Veselina, 1975, Județul Olt, Editura Academiei R.S.R., București.

[7]Dumitrașcu Monica, 2006, Modificări ale peisajului în Câmpia Olteniei, Editura Academiei Române, București.

[8]Iagăru, G., Vătămanu, V.V., Bălănescu, D., 2001, Clima și solurile județului Olt, Editura Sitech, Craiova.

[9]Lungu M., 2013, Agrometeorologie, Editura Universitară, București.

[10]Marinică I., 2006, Fenomene climatice de risc în Oltenia, Editura Autograf, Craiova.

[11]Sandu I., Mateescu Elena, Vătămanu V.V., 2010, Schimbările climatice în România și efectele asupra agriculturii, Ed. Sitech, Craiova.

[12]Săndoiu Ileana, 2001, Agrometeorologie, Editura Ceres, București.





## INFRASTRUCTURE OF AGRIFOOD PRODUCTS QUALITY ASSURANCE IN THE REPUBLIC OF MOLDOVA - BRANCH AND EXPORT APPROACHES

Cornel COȘER, Sergiu CHILIMARI

State Agrarian University of Moldova, 44 Mircești, Chișinău, Republic of Moldova,  
Phone:+37322432387, Mobile:+37369179187, Emails:cornel.coser@yahoo.com,  
s.chilimar2011@yandex.ru

*Corresponding author:* cornel.coser@yahoo.com

### *Abstract*

*The article aims to determine the state of development of infrastructure ensuring the quality of agrifood products in the Republic of Moldova through analysis and deduction of the related elements - regulatory basis, inputs, post-harvest network, quality of exported products; the involved working methods are present through the analysis of genesis of quality infrastructure, scientific abstraction of the institutional framework, logarithm of agrifood exports' unit value as well as quantitative analysis by exposing numerical values for each structural component. Study results highlight a quality infrastructure in formation, both legislative and institutional, also we witness a continuous connection to international/regional standards under the conditions of some degrading but still qualitative land resources, of more efficient plant varieties, with some minor exceptions. Concluding, we understand that both post-harvest network, as well as private investment in modern equipment of the agrifood industry continue to be the major challenges of the chain; as for the quality of products exported to the European Union/Commonwealth of Independent States, their highest index proved to be that for nuts, fruit and vegetable juices and sugar, in relation to the EU; sunflower oil, sugar, dairy products and natural honey in relation to the CIS.*

*Key words:* agrifood, branch, export, infrastructure, quality

### INTRODUCTION

Faced with numerous internal and external challenges, agrifood quality infrastructure of Moldova derives from the stringency of modernization of the regulatory framework and the agrifood sector as such. On the other hand, the reorientation of trade flows from traditional CIS (Commonwealth of Independent States) markets to EU (European Union) member states in large part mature, or to other destinations with growing domestic demands (such as, for example, Middle East and Southeast Asia countries) sets out the need to strengthen a pragmatic and workable system in argumentation of quality of local agrifood products.

In this regard, we refer to the national legislative sources, of national statistics, international sources and other materials that determine the consistency of the study.

### MATERIALS AND METHODS

In preparing this paper there were used techniques for assessing the quality assurance

system from a regulatory perspective, through historical method, or genesis, ways for determining the development conjuncture of involved resources, of investment in quality infrastructure and logarithmation Quality Index, tangential to exported products.

Using both primary and secondary data made possible the deduction of overall picture for agrifood products quality infrastructure.

### RESULTS AND DISCUSSIONS

The term of *quality*, generally accepted as definition determined by the client, involves a number of subjective and objective characteristics of agrifood product [2]. Quality assurance for agrifood products has become a necessity, in terms of technological progress (which allows the production of items with high physicochemical characteristics - appearance, color, odor etc.), of globalization and quality dynamic characteristic.

However, being a crucial element of agrifood quality, the food safety attracted the attention of decisional actors in determining the integral systems of quality management and

national infrastructure on its accomplishing. Chronologically, analytical chain of strengthening the quality infrastructure was initiated with the *Quality Infrastructure Concept* [8] that argued, in 2006, generically the consolidation of the legal framework, based on standardization norms, conformity assessment of products and National program for development of technical regulations, existing normative acts, but without an pragmatic support of coherence within a clear concept of quality infrastructure development. Later, it approached in a categorical manner the institutional aspect of food safety, *Food safety strategy for 2011-2015* being approved in 2011 [7], a document that was going to determine, based on the models of some European countries (Romania, Estonia, Poland etc.) its own approach to organize the food safety and setting the basis for institutional structure responsible for the area. This entity would become, by the Government Decision no.51 of 16.01.2013 [3] - *National Agency for Food Safety* (NAFS), which became the result of the reorganization and unification of several institutions which were responsible for the sanitary & veterinary area, phytosanitary surveillance, public health surveillance, etc. Having in its structure the *Direction of quality control and quality systems*, NAFS became the primary actor in ensuring agrifood quality throughout the production chain, according to the concept "from pitchfork - to plate".

Here it is attributable, among other things:

- ensuring the implementation of quality standards for all agri-foodstuffs;
- elaboration of documentation on implementation of quality standards;
- coordination of controls on quality;
- implementation of food safety strategy etc.

NAFS territorial network includes 10 regional posts for sanitary&veterinary and phytosanitary control, as well as Veterinary Diagnostic Republican Center. Figure 1 summarizes the issues mentioned above.

Pragmatically, it is necessary to identify the "pillars" of agrifood quality assurance mechanism, because they determine, in fact, the direction of actions for the purposes of system improvement.

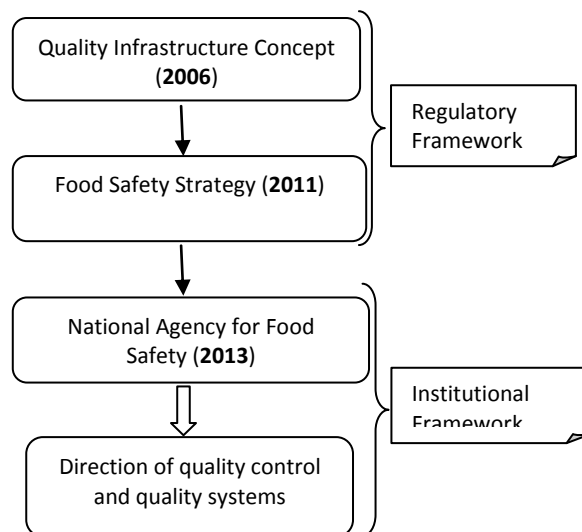

Fig. 1. Generic evolution of Agrifood Quality Infrastructure in the Republic of Moldova

In this way, we can refer to:

- 1) **Standardization** - important element of ensuring quality characteristics; this system is substantiated by Law no. 590 of 22.09.1995, with subsequent amendments [12]. Guaranteed by the logo "SM", standardization in Moldova is voluntary, but if the adoption of certain technical regulations refers to a certain standard, it becomes mandatory. 27 thousand standards (of which about 6000 are European) are currently adopted in Moldova. For agrifood exports, national standards necessity shall be established in the delivery contract.
- 2) **Technical regulations** - represent the basis of determining the minimum requirements for quality and safety that must meet agri-foodstuffs; this system is substantiated by the Government Decision no. 873 of 30 July 2004 "On approval of the National Programme for Development of Technical Regulations" [9] and more recently by the Law no. 420 of 22.12.2006 [11]. National technical regulations are usually developed based on international standards, but if there are national standards developed under the relevant international or regional ones, then they will become the basis of technical regulations concerned. Currently, in Moldova are adopted over 100 technical regulations and for agrifood sector (which concentrates about 40% of regulations), Government Decisions reflect the technical regulations for each category of product placed on the market,

for example - milk and dairy, bakery etc.

In this way, agrifood tariff headings are displayed in more than 25 developed technical regulations and where they do not exist yet (ie - preparations of fish or canned fish), they are transposed into "Register of products from the regulated area subject to mandatory conformity certification", document which has been reduced more than 6 times in recent years; there remained only the tariff headings for which have not yet been developed technical regulations [17].

3) **Conformity assessment** - closely related to the other 2 elements mentioned above, in Moldova, conformity assessment activity is regulated by the Law no. 235 of 2011 [10]. When placing a product on domestic market, the economic agent must have the certificate of conformity (issued by the certification body), test report (issued by an accredited laboratory) or hygienic notice, as set out in the regulations. Typically, an operator applies up to 5 standards, but the most difficult is the mechanism of implementation and quality assurance, whereas it is necessary the compliance of technological lines, endowment with advanced equipment. Thus, conformity assessment is determined by the technical regulations.

Also it is expressly provided that for the products intended for export, the existence of the certificate of conformity is not mandatory if in the export contracts is not indicated the requirement of this certificate or if the respective certificate of conformity is not a demand of importing country.

4) **Quality Management Systems** (ISO, HACCP related) - in Moldova, by Government Decisions no. 412 and 435 (2010) with reference to the hygiene rules of foodstuffs [5] and hygiene specific rules for food products of animal origin [6], the HACCP (Hazard Analysis and Critical Control Point) system norms shall become binding for agrifood industry enterprises. Started to be implemented from 1998 by canning production units, HACCP has not gained a massive spread, although it is binding on the categories of processors. In addition, there is a problem in quantifying the phenomenon, caused by the fact that they do

not know exactly the number of holders of such a system, since there are many providers of such services.

Since ISO, oriented on agri-foodstuffs, is a voluntary standard, a system of quality control, HACCP (ISO 22000) is a system to guarantee the product safety.

Thus, HACCP becomes a regulatory requirement from the state authorities, whereas ISO is required in terms of market and trading.

From the **entities** related to agrifood quality assurance domain, in addition to NAFS, we can mention the Product Certification Body (a department within the Standardization National Institute), accredited laboratories etc. The national framework for agrifood quality assurance starts from defining elements in evaluating the quality of crops [4]. Table 1 summarizes the issues related to **resources**.

Table 1. Resource components in ensuring qualitative agrifood products

Agricultural land according to grade, 2012		Irrigation	
Gradation of soil quality, points	Share in total area, %	Irrigated land in 1990, thousand hectares	Irrigated land in 2013, thousand hectares
81-100	27	230	144.6
71-80	21	Irrigation Centralized Systems	Mandatory to be rehabilitated
61-70	15	78	60%
51-60	15		
41-50	9		
21-40	6		
20	7		

With a quite important soil quality assurance (over 75% of agricultural land has more than 50 points of quality gradation) - significant component in obtaining qualitative agrifood products, Moldova remains to be noncompetitive in irrigation systems, critical point particularly in climatic conditions of the country. Not only the insufficient coverage network is worrisome with reference to obtaining qualitative products in commercial and timeliness aspects, but itself the outdated usefulness of the irrigation systems indicate that well over half of them require a stringent rehabilitation.

Another important element in quality infrastructure is related to **plant varieties registered and used** in Moldova. Going on line of varieties with the required originators and thus determining the superior qualities of agrifood products [13], we obtain table 2, which highlights the most widespread fruits and vegetables in culture.

As we can see, table 2 reveals that in the last 5-6 years, crop varieties used in Moldova became more competitive at the level of diversification and quality of seeds. The most important crops had as generators primarily European entities, with important traditions in modern agriculture - Netherlands, France, Germany, Great Britain.

However, at the level of some cultures, such as grapes, the registered varieties are pretty old and underperforming, some of them were introduced in the period 1947-1950.

Table 2. Plant varieties used in Moldova, by species and generators

Species	Main generators	Number of varieties
Sunflower	Romania, Netherlands, France	123
Sugar beet	Germany, Belgium	56
Tomatoes	Moldova, Netherlands	96
White cabbage	Netherlands, Germany, France	60
Potato	Netherlands, Germany	53
Onions	France, Netherlands	23
Cucumber	Netherlands, Germany	48
Apple	Moldova, Germany, Romania, USA	59
Plums	Moldova, Germany, Italy	24
Walnut	Moldova	14
Strawberries	Great Britain, Germany, Netherlands	3
Continuation of Table 2		
Table grapes	Moldova, Ukraine, Great Britain, Egypt, Hungary, USA	28
Wine grapes	Moldova, Ukraine, Germany, Austria, Hungary, France	32

The most important challenge in this chapter is the further implementation in culture of varieties with superior qualities that will ensure important harvests in terms of quality as well as quantity.

If we consider the following important element of ensuring agri-food quality infrastructure, namely the **post-harvest network** [18], we can see that the situation in

this area has improved in the last 3-4 years; currently in Moldova are located 187 cold storages for storing fruits and vegetables (signifying almost 20% of needed capacities).

This aspect is particularly important for the sale on foreign markets, especially since these deposits have a total storage capacity exceeding 178,000 tons. Negative is the fact that this network is heavily concentrated in the center of the country, where there are located more than 47% of all storage capacities and only 5 refrigerators are HACCP certified. At the same time, 85 deposits (i.e. 45%) were built in recent years, with the help of the Subsidy Fund.

Thus, high quality products retains its properties and can be traded, especially for export, outside the harvest season, ensuring uniform quality and a better price.

At the same time, we observe a dispersion of *calibration/packing systems* compared to storage locations and the more so it highlights a very small number of these units. In this way, only 3 refrigerators have sorting lines and also only 3 have "trey farmer" capacities (production of cardboard boxes following international standards).

The estimations of the Ministry of Agriculture and Food Industry (MAFI) shows that no more than 55% of exported grapes have gone through cold chain; for apples this indicator is only 27%; stone fruit, berries and vegetables have a more unfavorable situation. Hence there is the point when arise various problems on quality of exported products which are not placed in the "cold chain" and hardly support transportation and thus quality suffers in a meaningful way.

In this regard, the *packing house* becomes the operational place for handling agrifood products by the complexity of processes for calibration, cleaning, sorting by quality categories following particular parameters (variety, size, color etc.), packaging, palletizing and storage.

The infrastructure of **accredited laboratories** in agrifood sector consists of a total of 108 laboratories under the economic entities which provides the required aspects of interventions and tests. On the other hand, in Moldova there are 7 laboratories that are

accredited for quality assessment and certification of products for different agrifood classes - for the production of canned food, cereal products, alcoholic ones, of animal origin etc. A 3rd category of laboratories - 8 in total [14] - is related to activity of export to EU for the purpose of issuing the phytosanitary certificate and the inoffensiveness one, and 6 laboratories [15] are authorized to issue the test reports for international trade, including the Russian Federation.

From a **procedural standpoint**, the issue of conformity certificates cost and of laboratory procedures, it must be taken into account in redefining the policy concerning infrastructure for ensuring agrifood quality. At this moment, as destination approach, for the export of fruit and vegetables in EU the following documents related to quality are required: inoffensiveness certificate (issued by the NAFS), laboratory analysis reports and phytosanitary certificate, the procedure for its obtaining was simplified to 2 visits to NAFS (out of 5 in the past) and to 3 documents (out of 7 in the past).

It is also gratifying that **equipment and other materials investment** [16] in the long term related to food industry, began to take significant share in the total industrial investment (over 54%) and the share of the private sector begins to grow.

As diagnostic for **quality of agrifood products exported** to the EU and CIS markets we can approach the unit value of exports [1], which indicates, in case of higher values, a higher component of quality, of course without excluding the hypothesis of higher costs. Relationship of establishing the relevant values is initiated by determining the unit value of national exports -  $UV_{kt}^c$  (ie the ratio of the national exports value of commodity k, in year t, to the reference group and the quantity exported from the same good). Subsequently, this unit value is compared, by logarithm, with unit total value of the imports for the respective commodity reference group (Table 3).

Values in **bold** in table 3 show products with a Compared Unit Value Index Higher for Moldova's exports than reference area's Imports (EU, CIS).

Table 3. Presentation of the unit value of Moldova's agrifood exports relative to reference group's imports unit value, conjuncture of 2012-2013 years

Tariff heading	The unit value of exports (index of product quality, logarithmically - ICPL)	
	EU Related	CIS Related
Wine of fresh grapes	-0.713	-0.386
Walnuts	<b>0.059</b>	-0.559
Apples, pears and quinces	-1.686	-0.938
Grapes	-1.911	-1.025
Sunflower seeds	-0.122	-1.092
Sunflower oil	-0.165	<b>0.077</b>
Fruit and vegetable juices, unfermented	<b>0.085</b>	-0.567
Vegetables prepared or preserved otherwise than by vinegar	-0.472	-0.552
Sugar	<b>0.014</b>	<b>0.175</b>
Bovine meat	0.000	-0.198
Pork	-1.418	0.000
Vegetables - onion, garlic (tomatoes for CIS)	-0.517	-0.160
Dairy - milk and cream (cheese and curd for CIS)	0.000	<b>0.207</b>
Bird's eggs	0.000	0.000
Natural honey	-0.109	<b>0.288</b>

Thus, in the RM-EU relations, Moldova ranks best from the value point of view (in terms of quality), compared with the imports, structured on given products in the category *Walnuts* (ICPL=0.059), *Fruit and vegetable juices* (ICPL=0.085) and *Sugar* (ICPL=0.014); at remaining items, Moldovan products does not show higher unit values as other exporters on the EU market, despite the fact they conduct massive export operations so having large unit values and thus earning from the competitive conjuncture on the EU market (fact reflected in financial resources), a market with a significant purchasing power and a number of more than 500 million of consumers.

On the CIS market, national agrifoodstuffs proved unit comparative values higher to several positions as in the case of the EU, which is normal, given the economic similarities of their economies (RM and CIS). In this relationship, the most qualitative and performant proved to be *Sunflower oil* (ICPL=0.077), *Sugar* (ICPL=0.175), *Dairy - cheese and curd* (ICPL=0.207) and *Natural honey* with an ICPL=0.288 - the highest index of all products and for both reporting areas.

The market analysis thus involves the resultant of circumstances for the entire infrastructure of agrifood quality assurance, the constituent elements of which influence the quality of export goods.

## CONCLUSIONS

Infrastructure of agrifood quality assurance is reflected at the time of improving the regulatory and institutional framework in order to connect it to the models of the European Union.

Land inputs still have important qualitative features, and most varieties of crops began to be retrieved from the important European originators, in the last 5-6 years.

Postharvest infrastructure, very important in ensuring agrifood quality, is shaky, with limited facilities for refrigeration, calibration, packaging and with a concentration of more than 45% in the center of the country.

Out of a total of 15 reflected agrifood tariff headings, only 3 showed higher values than those of competitors on the EU market and only 4 on the CIS market.

## REFERENCES

- [1]Albu, L., 2012, Increasing the contribution of foreign trade to the accomplish the real convergence, Publishing House Economica, Bucharest.
- [2]Cumpanici, A., 2007, Guide for quality assurance in small and medium-sized processing companies, USAID, PDBA, p.5-6.
- [3]Government Decision Nr. 51 of 16.01.2013 on organization and functioning of the National Agency for Food Safety, <http://lex.justice.md/md/346423/>
- [4]Government Decision Nr. 409 of 04.06.2014 on the approval of the National Strategy for Agricultural and Rural Development for the years 2014-2020, <http://lex.justice.md/md/353310/>
- [5]Government Decision Nr. 412 of 25.05.2010 approving the Hygiene general rules of food products, <http://lex.justice.md/index.php?action=view&view=doc&lang=1&id=334708>
- [6]Government Decision Nr. 435 of 28.05.2010 approving Hygiene specific rules for food products of animal origin, <http://lex.justice.md/index.php?action=view&view=doc>

<http://lex.justice.md/index.php?action=view&view=doc&lang=1&id=334753>

[7]Government Decision Nr. 747 of 03.10.2011 on the approval of Food safety strategy for the years 2011-2015,

<http://lex.justice.md/viewdoc.php?action=view&view=doc&id=340498&lang=1>

[8]Government Decision Nr. 859 of 31.07.2006 on the approval of the Concept of quality Infrastructure in the Republic of Moldova, <http://lex.justice.md/index.php?action=view&view=doc&lang=1&id=317039>

[9]Government Decision Nr. 873 of 30.07.2004 on the approval of the National Programme for Development of Technical Regulations, <http://lex.justice.md/index.php?action=view&view=doc&lang=1&id=305242>

[10]Law Nr. 235 of 01.12.2011 on accreditation and conformity assessment activities, <http://lex.justice.md/md/342417/>

[11]Law Nr. 420 of 22.12.2006 on technical regulation activity,

[http://lex.justice.md/document\\_rom.php?id=9B7C4804:D17BC141](http://lex.justice.md/document_rom.php?id=9B7C4804:D17BC141)

[12]Law Nr.590 of 22.09.1995 concerning standardization, <http://lex.justice.md/index.php?action=view&view=doc&lang=1&id=343270>

[13]Machidon M., Ploșniță Gh., 2013. Catalogue of Plant Varieties for 2013, Chisinau, <http://asociatianuciferilor.com/wp-content/uploads/2013/11/Registrul-Soiurilor-de-Plante-Republicii-Moldova-2013.pdf>

[14]National Agency for Food Safety, Laboratories Export European Union, [http://www.ansa.gov.md/uploads/files/Laboratoare/Laboratoare%20export\(1\).pdf](http://www.ansa.gov.md/uploads/files/Laboratoare/Laboratoare%20export(1).pdf)

[15]National Agency for Food Safety, Laboratories Export Russian Federation, <http://www.ansa.gov.md/uploads/files/Laboratoare/Laboratoare%20export%20Federatia%20Rusa.pdf>

[16]National Bureau of Statistics of the Republic of Moldova, Investments in long-term tangible assets in the Republic of Moldova in 2013, <http://www.statistica.md/libview.php?l=ro&idc=168&id=4499>

[17]Nomenclature of products from the regulated area, subject to mandatory conformity certification, [http://lex.justice.md/UserFiles/File/2011/mo134md/nomenclator\\_1469.rtf](http://lex.justice.md/UserFiles/File/2011/mo134md/nomenclator_1469.rtf)

[18]Packing House, Ministry of Agriculture and Food Industry, <http://www.maia.gov.md/download.php?file=cHVibGljL3B1YmtpY2F0aW9ucy8xMzQ1ODc3X21kX3BpbmRpbGlX3BhcnZhLmRvYw%3D%3D>

## THE ANALYSIS OF THE INTENTIONS TO CONTINUE THE STUDIES IN THE HIGHER EDUCATION. CASE STUDY.

**Daniela CREȚU, Andrei Radu IOVA**

University of Agricultural Sciences and Veterinary Medicine of Bucharest, 1, N.Titulescu Blvd, Călărași, Romania, Phone: +40242.332.077, Fax: + 40242.332.077, Emails: danielacretu5@yahoo.com; andrei\_anglia@yahoo.com

**Corresponding author:** danielacretu5@yahoo.com

### **Abstract**

*The paper presents the results of a survey conducted in the high schools of Calarasi county. The purpose is to estimate the education option of the future graduates. The survey was conducted on a stratified sample, of 630 future graduates of 7 high schools in Călărași county. In order to inform closer to reality, the design of the questionnaire sought to identify options for the University of Agronomic Sciences and Veterinary Medicine Bucharest, following the evaluation by the pupils, of the group of university education offers. Almost all, of 96.7 % of pupils expressed their intention to continue their studies in the higher education, most of them continuing the tradition of the past years, to direct their options to the economic education, respectively 31%. The school population was divided into five layers, depending on the number of graduates registered in the University of Agronomic Sciences and Veterinary Medicine Bucharest, in the academic year 2014/2015. The demand for the University of Agronomic Sciences and Veterinary Medicine Bucharest represents 27% of the demand for the public education, most of them coming from the high schools with agricultural and economic profile. In order to improve the promotion strategy, along with the options estimation, the investigation aimed also to identify the main reasons for the choice made and to highlight the main sources of information. Analyzing the distribution of reasons, we found out that the first reasons are: good training, existing specializations, internships abroad, providing accommodation.*

**Key words:** agricultural profile, economic profile, education option, high schools, school population

### **INTRODUCTION**

According to the European Council conclusions of 12 May 2009 concerning the strategy of the European Union (EU) in education and training sector in the period 2010-2020 [10], at least 40% of people aged 30-34 years should have completed tertiary education (ISCED levels 5 and 6) in 2020.

The graduation of a faculty is an essential condition in the context of the EU desire to have a knowledge-based economy, implicitly a workforce with a high level of education, able to face the competition in the common market. A high level of education is associated, at the micro level, with the chance of obtaining a higher income and at the macro level, with a high degree of economic development [6].

The motivational aspects and attitude towards the school in the context of Internet competition as an information tool constitute

together only one dimension explaining the school performance and the desire to continue the studies [3].

The family income, the parents support to their children, the size of the locality in which the educational institution is situated (with emphasis on the difference between the urban and rural area), the distance between school and pupils house (measured by the time required to cross the road from home to school) are other variables that the researches in education have taken into account when studying the intention to continue the studies in the higher education [4].

The main purpose of the present study was to identify the key factors that may be considered when discussing about the policies in the education sector regarding the access and equity at the university level, and regarding encouraging the young people to continue their efforts to pass the bachelor degree studies, respectively master studies.

The European policies regarding the education and employment highlight the need to continue study for a larger number of young people, this is the only way to build a knowledge-based economy [8]. However, in Romania, the number of students is continuously decreasing, consequence of the lack of interest of the young people for the higher education, but also of the reduced number of high school graduates who do not pass the baccalaureate exam. Thus, it must increase the percentage of people who still want a university degree, as a key objective of the European Union, both in the employment and in the education sector [7].

Therefore, in this study, we sought theoretical explanations (models) that allow us to understand, mainly, the young people reporting to the higher education and possible sources of inequity when it refers to the access to the higher education.

## MATERIALS AND METHODS

Assuming that the educational and employment options of the high school graduates are influenced by the current socio-economic context, we initiated a sociological survey based on a questionnaire with the objective of identifying the factors that influence the decision of the high school pupil to continue studies at university level, the options of the high school graduates in order to identify the potential candidates to USAMV Bucharest.

The research was based on the questionnaire method applied to the pupils in the sample. The instrument used had 11 closed/semi-closed items and an open item, focused on: the profile of classroom in which the pupils is; intention after graduation; sources of information about the faculty/occupation they choose; the locality where they want to study; the field of study they choose; the reasons to continue education; the criteria for the faculty selection; the state/ country in which the student wants to work after the high school; the sector they choose employment; the current residence and the financial situation of the parents etc. Some features of the future candidates of the university, the profile of

high school study and gender distribution were highlighted, too. The sample was made up only of the pupils present in class hours when the questionnaire was given.

In relation to the structure of the candidates and the possible resources of the research - direct administration in schools of the instruments, by the representatives of the Faculty of Management-Calarasi branch, the survey was conducted on a stratified sample, of 630 future graduates of 7 high schools in Calarasi county, in the period 8-15th December 2014.

## RESULTS AND DISCUSSIONS

The distribution according to the pupils gender in the research sample was: 47.5% boys and 52.5% girls, as it is shown in figure 1.

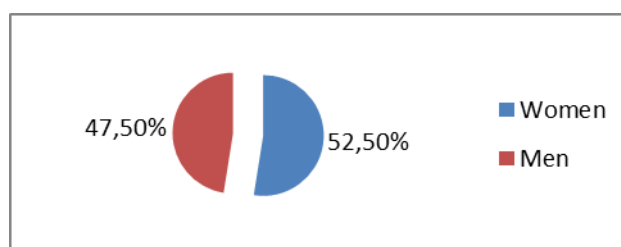

Fig. 1. The structure of sample from the point of view of the respondents gender

The distribution depending on the pupils background, respectively the profile they graduated, is presented in figures 2 and 3.

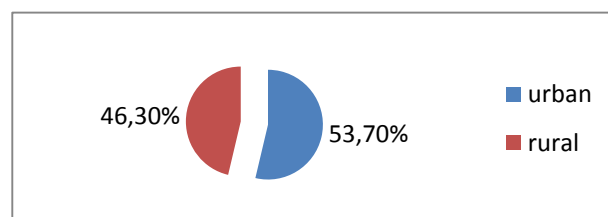

Fig. 2. Distribution of pupils in the sample, according to their background

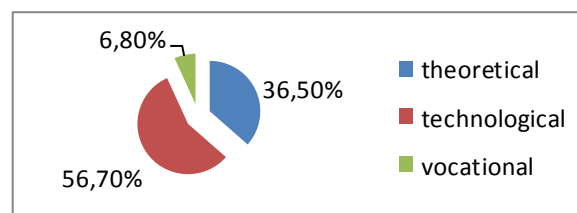

Fig. 3. Distribution of pupils in the sample, according to the high school profile

When asked about the intention they have



after graduation, pupils had as option to continue education, employment or both in parallel (Table 1).

Most high school pupils are decided after graduation to attend a faculty in Romania (91.3 %). A low percentage of the respondents want to go to the university abroad (5.4 %). Many students want after graduation to employ and to attend a faculty in Romania (31.6 %). We can say that, among the high school pupils, the option of leaving abroad (for studies or not) is less present than the option of remaining in Romania.

Comparing the intention after graduation depending on the respondents gender it results that girls are more focused on continuing study, and boys more on employment. It also results that more pupils from the urban area seek to continue education, compared to those from the rural area, who rather aim the integration on the labour market.

Table 1. Structure of respondents, on the intention to continue studies

INTENTION AFTER GRADUATION	STRUCTURE, ON GENDER -no-		AREA THEY LIVE IN -no-	
	GIRLS	BOYS	URBAN	RURAL
I continue studies	228	189	229	179
I employ	8	15	6	17
I continue studies and employ at the same time	95	104	103	96
TOTAL	331	299	338	292

A stage of career planning is the collection of information on the educational and occupational opportunities. The accuracy of the information obtained is essential for the graduates to choose according to their interests, values and lifestyle (Johnstone, Bruce and all., 2010).

When asked about the sources they use for information, the graduates could choose more options than those listed in the questionnaire. The family and the group of friends are the main sources of information the graduates choose for making decisions after completing the high school, the direct promotional campaign made in the high school regarding the educational offer is considered as a second source of information, the third source is the Internet and media. The subjects in technological high schools have given more importance consultation with third parties,

compared with those from the theoretical high schools.

These differences are due to the differences in the general areas in the previous school year between the respondents in the three types of high schools.

As regards the place where they would like to study, Bucharest University Center remain in the pupils preferences, followed by Constanta University Center. Most of them go to universities situated near Călărași county. At the time of the survey, 7.2 % of the respondents said they want to continue their studies in Călărași, and of these 74 % intend to employ.

Table 2 highlights the study options depending on the graduate profile. In general, there is a good correlation between them, but there are also options that are not in the profile graduated by the pupils.

Table 2. Options for the study field, depending on the graduated profile

The field option	Graduated profile					
	real	human	services	technical	natural resources	other
Exact sciences and IT	22	8	1	12	6	2
Nature sciences	5	4	3	3	11	1
Human sciences	2	9	1	2	2	3
legal sciences	7	13	3	4	1	1
Social and political sciences	3	14	6	4	2	2
Economic sciences	12	10	61	5	3	-
Architecture and town planning	4	6	-	1	-	-
Agricultural sciences and veterinary medicine	11	10	53	42	51	15
-of which, USAMV Bucharest	11	10	51	39	46	13
Engineering sciences	13	11	6	25	3	2
Management and economic engineering	15	6	15	15	16	5
-of which, Călărași branch	6	2	11	10	11	5
Military sciences and information	1	1	-	1	1	1
Medicine/pharmacy/stomatology	9	7	-	-	1	-
Psychology/education sciences	2	11	2	1	3	2
others	2	5	-	3	4	2
TOTAL	108	115	149	118	104	36

The analysis of the options for the study field depending on the gender of subjects, highlights that girls are more attracted by the economic, legal, human sciences, while boys rather aim a career in IT field, engineering and public safety.

It is surprising, perhaps, that pupils from the technological profile want to follow at a much higher rate, faculties of economic sciences (22.8%) than the faculties of engineering sciences (12.5%). A first explanation is that 41.1% of the pupils in service profile (the Technological profile) are interested in attending a faculty in the field of economics. A second explanation relates to the crisis of the economic sectors that need engineers in the context of reducing the industrial sector and increasing of the service sector.

Table 3. Motivation of choosing the faculty, depending on the graduated profile

How important are, for you, the following criteria to decide for the faculty?	Theoretical PROFILE	Technological PROFILE	Vocational PROFILE
	NUMBER OF PUPILS		
Own aspirations	65	20	1
Material gain	41	88	8
Faculty profile	19	34	2
State faculty	19	21	1
Near home	7	34	2
Taxes	11	29	4
Profession prestige	41	29	2
Admission based on file, without exam	6	53	4
friends/colleagues who attended or are preparing to attend this faculty	7	11	7
There is practice abroad	2	33	3
There is distance learning (no attendance)	5	19	2
TOTAL	223	371	36

Comparing the respondents' answers according to their origin, we consider that the option for the study fields is influenced by the existing employment opportunities, that is, graduates are prepared for those professions that are more likely to employ in their residence.

From the processed data, it results that the majority of the pupils believe that the most important criterion in choosing a university is that of *own aspirations*, followed by *material gain* and *professional prestige* for which they prepare. For 8% of the pupils *near the home* is

the most important criterion in choosing the faculty (Table 3).

The comparative analysis of the data on the past two years shows a higher valuation by the graduates in 2013 of the material gain and professional prestige. It also notes that the family influence tends to grow.

Ranking the criteria for the selection of the faculty is not significantly influenced by gender or origin, but still we can appreciate that for boys, material gain and professional prestige are important criteria than for girls.

When choosing a faculty, compared to the pupils from the high schools with theoretical profile, for the pupils in the high schools with technological profile is more important that the taxes are low, easy admission, based on the file, or to be able to attend distance learning. These results also arise due to the differences between the averages obtained at school, as long as those in the technological profile have significantly lower average than those in the theoretical high schools. Also, those in the high schools with technological profile give more importance to the idea of "having friends/acquaintances who attended, or are preparing to attend this faculty".

Paradoxically, the pupils in the high schools with technological and vocational profile are those who want to know if the faculty can be distance learning, due to the low average. However, the technical and vocational fields can be taught in a difficult way in the form of "no attendance" (given the existence of laboratories, practical tests), but rather the prerogative of the classic education, with compulsory attendance. Beyond the low averages, it is possible that the pupils in the technological and vocational high schools to move towards distance learning because they think to get a job, compared with those who completed theoretical high schools.

As it is shown in Figure 4, the majority of respondents, respectively 56.85%, come from families with a monthly income of up to 2,000 lei. These pupils are going to continue their studies, to state faculties that have more budget places, but they not follow their own aspirations.

The pupils in the rural area are less interested in attending a faculty.

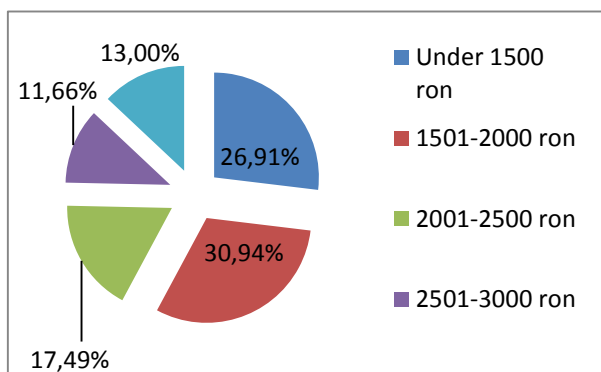

Fig. 4. Structure of pupils in the sample, according to the family monthly income

A first possible explanation is that parents of the pupils in the rural area have a lower education level and this creates lower expectations from the pupils to continue their studies at university level. A second possible explanation is based on the reality that there is a positive correlation between the family income and the locality size (the pupils in the rural area live in families poorer than the pupils in the urban area), which implies an inequality on the chances of a pupil in the rural area to attend a faculty.

Although the image of higher education in Romania since the late 80s may seem more idyllic, in fact it is a distorted image, given that only 9% of the high school graduates had access to a place in higher education institutions and to state support (scholarships, homes, transport facilities, student camps, student clubs, etc.) to complete their studies [9]. Thus, it is required an education system able to function as a key element of progress and of socio-economic development, by ensuring a fair access to the higher education programs for the children who come from all social backgrounds.

In addition to information about future graduates, the following features of the segment of pupils who expressed their intention to continue studies in USAMV Bucharest, are presented:

\* in terms of the graduated study profile, the sample distribution is shown in Figure 5. The first place is service profile, with 29.8% of the pupils' intentions, followed by natural resource profile, with 27% and technical profile with 22.9%.

\* the gender distribution of possible candidates to USAMV Bucharest, reflect a relation of 61.7% compared to 38.3%, for boys.

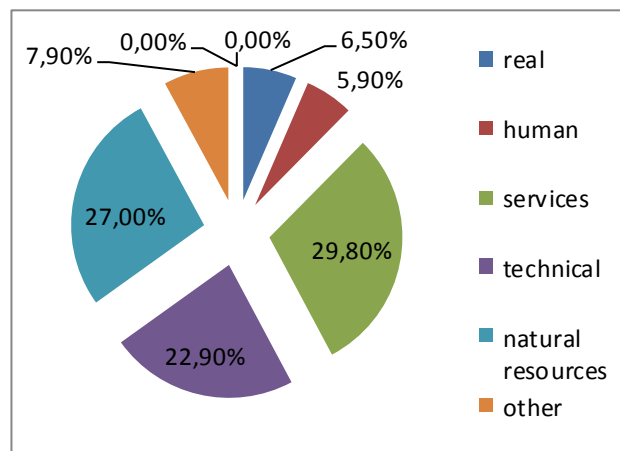

Fig. 5. Study profile of potential candidates of USAMV Bucharest

The main reason to continue the studies is the premise that the diplomas/knowledge/ skills gained after completing higher level studies would increase the chances for employment, in better paid jobs [5].

Many of the young people surveyed believe that our society values the education and, therefore, continuing study is a way to form a better image at the community level. These issues we encountered in other studies of graduates with leadership [2].

## CONCLUSIONS

The results presented in this study confirmed a number of older assumptions (eg the correlation between income and parents' education level and children's educational path) [1].

After the information is obtained from the acquaintances and friends (31%), the direct promotion done in the high school, regarding educational offer of our university is the second source of information (29%), for the graduates who expressed the option for the University of Agronomic Sciences and Veterinary Medicine Bucharest, the third source being the Internet (22%).

Other elements, relatively newer, but appeared on the agenda, such as the higher concern for quality of the programs that pupils

graduated and how they correlate with the labour market.

The increasing number of graduates who intend to employ at the end of the high school correlates with the socio-economic situation at national level, which is reflected negatively on the family budget.

Based on the graduates' aspirations and parents expectations, it can explain why a greater number of graduates from the urban area wants to continue education, education is more valued in this area.

In general, there is continuity between the specialization in the faculty which pupils choose, and the profile they graduate.

However, there are options for a completely different field of study that enables us to believe that either the initial orientation of the pupils was not appropriate to their interests and competences, or their choice today is not well founded.

The graduates of the technological profile are to a great extent the "nursery" for the labour market both at home and abroad.

Their own aspirations and the material gain are issues that are on the top two positions in the hierarchy of the criteria according to which graduates choose both the faculty and the profession. This reflects on the one hand, the stability of their motivational system, and on the other hand, the method of the graduates adaptation to the current socio-economic context.

## REFERENCES

- [1]Cretu, D., Constantin, D., Iova A., Neagu C., 2010, The level of education and training in rural county of Calarasi, International Symposium-Agrarian economy and rural development-realities and perspectives for Romania, 23-24 september 2010. ARS ACADEMICA Press House, Bucharest, 56-62
- [2]Cretu, D., Tudor, V., Iova A., 2012, Autocrat versus democratic leader. Case study in public institutions from county Calarasi. Revista Economica, Journal of economic-financial theory and practice, Supplement No. 6/2012:11-18
- [3]Cummings William K., 2007, Education Institutions. Bucharest: Editura Comunicare.ro.:18-19
- [4]Iova, A., Lascar E., 2013, The evolution of the work resources in Romania. Case study, Calarasi county. Scientific Papers Series "Journal of the Union of Scientists in Ruse" Angel Kanchev University of Ruse, Bulgaria, 25-26 octombrie 2013, Volum 52, Seria 5.1,

2013, Economics and management

[5]Johnstone Bruce, Marcucci Pamela, Sondergaard Lars, Moarcăș Mariana, Sandi Ana M., Pricopie Remus, Ciucă Ion, Reinhardt Zeno, Jitaru Gabriela, 2011, Introducing a Student Loan Scheme in Romania. A Discussion Paper. Washington D.C. and Bucharest: World Bank and Ministry of Education, Research and Youth.

[6]Johnstone Bruce D., Marcucci Pamela N., 2010, Financing Higher Education Worldwide: Who Pays? Who Should Pay?. Baltimore: The Johns Hopkins University Press.

[7]Richins Marsha L., Dawson, Scott, 2009, A Consumer Values Orientation for Materialism and Its Measurement: Scale Development and Validation, The Journal of Consumer Research, 19 (3):303-316

[8]Rothman Sheldon, 2011, School Absence and Student Background Absence Factors: A Multilevel Analysis, International Education Journal, 2 (1):59-68

[9]Sadlak Jan, 1990, Higher Education in Romania, 1860-1990: Between Academic Mission, Economic Demand and Political Control. Buffalo: University of New York at Buffalo

[10]The European Council, 2009, Conclusions of the Council of 11th May 2010 on the social dimension of the education and vocational training – ET 2020 [2010/C 135/02]. Brussels: Official Journal of the European Union.

## SUSTAINABLE MANAGEMENT PLAN APPLICABLE FOR ECOTOURISM CERTIFICATION SYSTEMS

Romeo Cătălin CREȚU, Petrică ȘTEFAN

University of Agricultural Sciences and Veterinary Medicine of Bucharest, 59, Mărăști Blvd, District 1, 011464, Bucharest, Romania, Phone: +4021.318.25.64, Fax: + 4021.318.25.67, E-mails: creturomeocatalin@yahoo.com, stefanmarian2004@yahoo.com

*Corresponding author:* creturomeocatalin@yahoo.com

### Abstract

*The purpose of this study is to introduce the certification procedure of ecological tourism as well as the criteria that have to be fulfilled by the lodging units whose desire is to voluntarily adhere to this new form of tourism. In Romania, the Certifying System in Ecotourism is used by the AER (Romanian Association of Ecotourism) and that adjusts the international experience into the national context. This is developed as the same as the Accreditation Program in Nature and Ecotourism promoted by the Australian Association of Ecotourism (NEAP is the first accreditation system in ecological tourism) and in conformity with Nature's Best of the Swedish Association of Ecotourism (the first accreditation system in Ecotourism in the northern hemisphere). An important element in the certification procedure consists of drawing up a plan of sustained development which has to respond to the entirely certification requirements. The hereby study allows to see a model of sustained development plan that maybe used by managers and directors of lodging units which wanted to acquire this certification of tourism.*

*Key words:* certification system, ecotourism, management, principles of ecological tourism.

### INTRODUCTION

In agreement with the Global Organization of Tourism, Ecotourism consist in a form of tourism where the tourist's principal motivation consists into observe and to appreciate nature and local traditions linked to nature that must fulfil the next conditions:

- Nature protection and conservation;
- To use the local human resources;
- Educational character, appreciation for nature
- tourists and local communities' alertness;
- A minimal negative impact on the social-cultural and natural environment.

The development of a Certification System in Ecotourism is imperatively needed as a mechanism which puts into practice the basic principles of Ecotourism for ensuring the nature conservation and the sustained development of local communities through tourism. Those are some important steps taken forward given the fact that, starting with March, 2003, the Global Organization of Tourism has made a proposal to governments to bear the initiatives that promote the certification for sustained tourism (Bran, 2007). [3].

### MATERIALS AND METHODS

The development of the ecological tourism assumes the following principles of ecotourism: Focusing on natural areas; Contribution to preserving nature; Interpretation of the Eco touristic products; The principles of durability; The development of local communities; Tourists' level of satisfaction; Adequate promotion of marketing.

The data collected linked to the *Certification System in Ecotourism* have been processed, interpreted and involves the fulfilling of all general principles and the criteria which are checked and scored.

### RESULTS AND DISCUSSIONS

**The principles of Ecotourism** are approved and promoted by the Romanian Association of Ecotourism (AER) and are based on 2 international models: Nature and Ecotourism Accreditation Program developed by the Australian Ecotourism Association and Nature's Best, the accreditation system promoted by the Swedish Ecotourism

Association. These principles should be put into practice both by those who try to develop Eco touristic products, as well as by those that plan the development of some area based on ecotourism. (Fig.1.)



Fig.1. The Principles of Ecotourism

*Focusing on natural areas* – Ecotourism concentrates on direct and personal experience in nature, in a natural environment and it is based on using it, respectively of its geomorphological, biological, cultural and physical features. Therefore, the accent on the natural area becomes very important in ecotourism planning, management or developing.

*Interpretation of the Eco touristic product* – Ecotourism can offer a lot of opportunities to have experiences in nature that can lead to an appreciation, a better understanding, and joy to discover and protect nature and local traditional culture, both for tourists, as well as for the local residents. The Ecotourism is attractive to those visitors who are willing to interact with the natural environment and who desire to increase their knowledge, appreciation, comprehension and pleasure to different levels. Those who try to develop and to coordinate Eco touristic activities must offer a good level of comprehending the values both natural as cultural of the visited areas, often by using properly trained tourist guides and providing accurate information

both prior as well as during the entire experience. The interpretation level and type are designed, planned and gifted in such a manner so that it answers to the client's interests, expectations and needs, by including a wide range of both personal and non-personal interpretation possibilities. Therewith, as far as the destination and the Eco touristic products are concerned, it is very important to forge the opportunity for those rural community residents to gain access to information and to interpretation gifted by the Eco touristic project developed in the respective area (Beciu S.). [2].

*The principle of durability* - seen from the perspective of preserving the natural habitat – The ecotourism activities and their planning should offer the best planning support and tourism practices from the perspective of nature protection and sustained development. The tourism activities should be planned and progressed so that to reduce the impact produced on nature. The Eco touristic product unfolds is administrated so that it preserves and capitalizes the cultural and the natural environment where it can be finding, by acknowledging and putting into practice the activities that characterize the sustained tourism (Bran, 2005) [4].

*Contribution to preserving nature* – Ecotourism help to preserving natural areas. Ecotourism involves the participation to protecting the visited areas, by giving constructive possibilities for a reliable management and, by this way, preserving the natural areas (e.g.: offering financial support within rehabilitation programs of natural areas, gathering waste left behind by tourists or helping to preservation organizations). *Contribution to the development of local communities* – Ecotourism offers sustainable contributions concerning local communities. Local community is commonly part of the Eco touristic product. Benefits of ecotourism should be allocated in their vast majority also to local communities.

Local benefits can come from purchasing local goods and services, using local facilities and using local tourist guides. The ecotourism activities and their planning must ensure an attenuation of the negative

impact on the local visited community and on their life style, by supplying in the same time long term constructive contributions for these communities.

As a result, ecotourism must equally bring out the cultural component of the visited area and helping to protecting this resource (Honțuș, 2005) [5].

*Tourists' level of satisfaction* – Ecotourism should answer of tourists' expectations. In developing Eco touristic products, one must take into account that, generally speaking, potential tourists in this field have a high level of education and more expectations. Therefore, the satisfaction level related to the Eco touristic product is essential, the experience offered fulfilling or even surpassing the tourists' level of satisfaction (Honțuș, 2012) [6].

*Adequate marketing* – That regards carrying out marketing adequate which results into realistic expectations. Ecotourism marketing give customers complete and accountable information which result into increasing respect for the cultural and natural environment of the visited areas and of tourists' level of satisfaction.

Table 1. The Certification System in Ecotourism

GENERAL PRINCIPLES	CRITERIA
<b>Principles of sustained management of the guesthouse</b>	The criteria of demonstrating a sustained/long-lasting and efficient management of the guesthouse.
	The criteria of implementing a durable management system.
	The criteria of observing the national and international laws.
	The criterion of personnel's continuous training.
<b>Product focused principles</b>	The criteria of concentrating on natural areas.
	The criteria of interpreting the Eco touristic product.
	The sustainability criteria seen from the perspective of preserving the natural habitat.
	The criteria of contribution to conservation.
	The criteria of contribution to developing local communities.
	The sensitivity criteria towards culture and local traditions.
	The criteria concerning the tourists' level of satisfaction.
	The criteria of adequate marketing.

Source: <http://eco-romania.ro> - The Romanian Ecotourism Association [9].

**The certification system in Ecotourism** is enforced depending on two categories:

- Ecotourism programs offered by tourist guides or tour-operators (maximum 15 participants);
- Small guesthouses from rural and natural areas (maximum 25 rooms).

As far as guesthouses are concerned, the C.S.E. involves the fulfilling of general principles and then of some criteria which are checked and scored in Table 1.

*Vision* - Guesthouse offers touristic services with a minimal impact on nature and aims for grow the quality of life in those communities to which it belongs by an adequate behaviour towards employees and promoting culture, products and local traditions. [10]

### Sustained management plan (SMP)- Content Proposal



Fig. 2. Elements of the Sustainable Management Plan (SMP) [11]

*Goals:*

- Reducing the environmental impact and preserving natural resources;
- Provocation the development of the local community by hiring staff from local communities and by promoting local culture and traditions;
- Providing good quality and secure services;
- Both, tourists and employees, not only benefit of the trust in their jobs, but also of the one in the activities they undertake. [10,12]

*A. Protecting natural resources and diminishing the environmental impact* can be reached by decreasing water consumption, lowering the quantity of dissipation and garbage, reducing the energy consumption and the impact on air, ground and water.



□ In order to *lowering the water consumption* we suggest the following: the use of shower heads with low streaming and buttoned faucets; toilets to have vessels with controllable water stream; showers to be fitted in bathrooms; using a little quantity of water for plants (watering systems or water dripping plants mainly during in the evenings or in the mornings); collecting rain water and using it for some activities; assuming other means of cutting down the volume of used water; displaying written warnings for reducing the water losing; encouraging tourists to use towels over several times and days; connecting all touristic features to a draining system or inserting a water collecting, retaining and treatment system or a system for ejecting residual waters to a water treatment plant.

□ *Diminishing the quantity of garbage and waste*: purchasing materials so as to escape by packages in excess; to use as much as possible to use bio-degradable packages; use only recipients which are re-usable or bio-degradable (like glasses); use disposable items (utensils or recipients) only in some special situations, maximum one time by person by stay; encourage both employees and customers to take part of programs for collecting, diminishing and recycling the quantity of waste; gather and remove all noticed garbage; to make composts of the organic waste; organize and subsidize (labour, finance) cleaning days (once a year at least).

□ *Lowering the energy consumption*: use fluorescent light over 90% in place of incandescent light; rooms can be naturally aery; over day light use the natural light (as much as possible); use solar energy; the loss of heat through doors and windows can be diminished by an adequate sealing, the usage of double or triple windows and insulation strips; one of the employees trained in this way is authorized with making the energy consumption more productive; heat is produced and distributed by centralized installations; electrical equipment appertain to “energy efficient” (energy class A); at least 50% of the building have to be made by wood or by other natural materials; itineraries, tours and schedules are planned so that the travel

time and distances are shortened; encourage tourists to use an efficient transport from a fuel point of view (e.g. providing bikes when they visit tourist objectives); to convince employees to go on foot, by bike or by public transportation in order to get to work and not only for that; all vehicles to be well maintained (technical check-up to date); when picking and/or buying vehicles to make efficient choices from the fuel consumption point of view; recommended to use vehicles that consume less than 9-10 litres/100 km.

□ *Lowering the impact on air, water and ground*: enhancements and touristic activities (e.g. buildings, pathways) do not determine to remodelling the ground, make changes of the rivers' courses, entirely termination of vegetation...; to utilize fences, undergrowth's, barriers or other corresponding marks for maintaining movement in the areas designated for some categories of users; waste is stored in special designated places; the regular point of the noise made by the ensemble of activities related to the product (transport operations, concerts, music, telephones, public communication systems, equipment's and mechanical installations) does not meaningfully exceed the background noise of the region; servicing and maintenance units caused noise are located at some distance from the quiet areas or they are soundproofed.

*B. Motivating the development of the local community* by hiring employees from that area and by promoting all local traditions and culture from the region (Stefan, 2012) [7].

Actions made for stimulating the development of the local community are the following:

- The turn to account of local tourist guides' services for looking off the significant tourist attractions and for systematically making ready other local tourist guides;
- The turn to account of other persons' services on a local level (e.g. kitchen staff, transport, etc.);
- Encouraging the purchase of local souvenirs and products;
- Utilising other services from that area: guesthouses; renting bikes, carts etc.;
- Giving money for creating and developing the local infrastructure and the local events (e.g. festivals and other traditional holidays);



•Giving the chance for the students/youngsters who live in the region for practising, in order to accumulate work experience in the ecotourism branch.

*Promoting local traditions and local culture:*

•Informing tourists about the behaviour code that should be adopted inward the local community;

•Showing tourists the most important traditions of the region, encouraging the participation in traditional festivals;

•Preparing and serving specific food for the respective area especially;

•Buying products from the region as much as possible: souvenirs, food, drinks, etc. (Beciu, 2011) [1]

*C. Insurance of good quality services:* we must have carried out a risk analysis that cover the activities impacting both on the environment, as well as on the safety of work, as well as identifying the measures against these risks; in some situations, there is an employee's responsible for resolving a problem as soon as possible; tourists should have access to a list with persons of contact in case of emergencies that includes: the fire fighting department, the mountain rescue, hospital, the administration of the natural habitat and others; all the company's employees have to wear the "safety equipment" when it is required; the correct utilisation of the equipment is explained by the specialized companies/persons; at least one of company employee is prepared for giving the first aid. The first aid kit is available at any moment and it is situated in an easily accessible location.

*D. Employees and customers (tourists) enjoy both of the confidence in their jobs, as well as of the activities that they undertake:* all employees of the company have insurances according with the type of activities they undertake; tourists get clear information about the insurances covered by the company's product (Tindeche C., 2013). [8]

## CONCLUSIONS

The purpose of the study revealed the certification procedure in ecotourism, as well as the criteria that must be fulfilled by the lodging units that voluntarily wish to adhere

to this modern type of tourism. In our country, the Certification System in Ecotourism is used by the Romanian Ecotourism Association (AER) which adapts the international experience to the existing context.

The present study showed a sustained management plan as a model that can be used by managers or owners of the lodging units that desire to acquire that certification in tourism. Guesthouses that implement the certification in tourism have a series of benefits, such as: it allows customers to identify better those products that can offer great experiences linked to nature and rural culture; contributes to grow up the level of confidence in Romanian ecotourism items on the international market; becomes a marketing instrument for guesthouses owners and for tour-operators; guarantees a higher quality point of services; contributes actively to protecting nature; helping local administrations in the preserving areas with developing of a tourism form with a minimal impact; offers a platform for shared activities between the entrepreneurial sector and the nature protecting organizations.

## REFERENCES

- [1]Beciu, S., Popa, O.E., Nistor, Ș., Olteanu V., 2011, The Socio-Economic Dimension Of Rural Development For The North -East Region Of Romania. African Journal of Agricultural Research
- [2]Beciu, S., Honțuș, A., 2013, Regional development solutions: leveraging tourism at Neamț county in the north-east region of Romania, International Business Information Management Association (IBIMA), 20th IBIMA Conference, Kuala Lumpur, Malaezia, pp. 1087 – 1098, IBIMA Conference Proceedings
- [3]Bran, F., Bran, P., Rădulescu, C. V., Ioan, I., Bran, A.G., Crețu, R. F., 2007, Model de dezvoltare economică și socială a orașelor românești riverane Dunării, Editura ASE, București
- [4]Bran, F., Crețu, R. F., 2005, Probleme economice și ecologice ale Dunării și Mării Negre, Ediția a II-a, Editura ASE, București
- [5]Honțuș Adelaida C., 2005, Amenajarea agroturistică a teritoriului, Editura CERES
- [6]Honțuș Adelaida C., 2012, Launch international circuit in rural tourism development through a tourist village Polovragi Gorj. Scientific Papers. Series "Management, Economic Engineering in Agriculture and rural development", Vol. 12(4): 142-148
- [7]Stefan, P., Cretu, R.C., Micu, M. M., 2012, "Economic crisis and the implications on rural tourism

and sustainable development in Calarasi County."

Revista Economica 1 (2012): 799-803.

[8]Tindeche Cristiana, Petrică Ștefan, Muscănescu Alexandra, 2013, "Research on possibility for implementing eco-label for accommodation services in agrotourist guesthouses." *Lucrări Științifice Management Agricol* 15.4 (2013): 70.

[9]<http://eco-romania.ro> – site-ul Asociației de Ecoturism din Romania, accesat 10.01. 2015

[10]<http://www.gov.ro/ministerul-mediului-si-schimarilor-climatice/> site-ul Ministerului mediului și schimbărilor climatice, accesat 10.01.2015;

[11]<http://www.gov.ro/ministerul-dezvoltarii-regionale-i-administra-iei-publice-> site-ul Ministerului dezvoltării regionale și administrației publice, accesat 11.12 2014;

[12]<http://www.gov.ro/upload/articles/117011/program-de-guvernare-2013-2016.pdf>, accesat 13.01. 2015.

## **SUSTAINABLE DEVELOPMENT AND FOOD SECURITY IN THE CONTEXT OF AGRO-FOOD SECTOR OF MOLDOVA'S INTEGRATION INTO THE EUROPEAN UNION**

**Tatiana DIACONU**

Moldova State University, 60 Mateevici Alexe street, MD-2009, Chisinau, Republic of Moldova, phone: +373 22 57 77 75, E-mail: tatiana.diaconu@mail.ru

**Corresponding author:** tatiana.diaconu@mail.ru

### **Abstract**

*In this research we intend to do an analysis of the economic and commercial policies development of the agro-food sector, in terms of ensuring the food security of the Republic of Moldova, in the context of integration into the European Union. We will mention international best practices, but also the EU member countries to assess the process of modernization of agriculture; marketing analysis of domestic agricultural products compared to other EU member countries, policy analysis for the development of agro-food production necessary to ensure Moldova's food; elaboration of recommendations to reduce the risks in the agro-food sector of Moldova.*

**Key words:** agricultural protectionism, commercial policies, food security, health security

### **INTRODUCTION**

The evolution of society, in general of global economic situation, as well as all the major problems facing the world, currently requires the identification of certain viable solutions designed to solve its problems. It is well known that we are going through a stage of fundamental, structural and conceptual changes in many fields, if not in all life field.[1]

At the same time, it is becoming more obvious that classical economic theory has been overtaken by economic practice and it is trying to outline a new theory that will be able to analyze and explain economic phenomena taking place today and, at the same time to be able to forecast their trends and developments towards a sustainable development. At the moment we can say that sustainable development can be considered as a transitional solution in this period of change where "economic theories finds a small background, remaining only economic theorems, ie formulas and formulations through which are described or explained specific phenomena or are solved concrete problems without surprising the economy as a unitary system.[2]

### **MATERIALS AND METHODS**

During the development of this research, we used different research methods, such as: method of comparison, logical method, the method of analysis and synthesis, etc., to determine the extent of comparing the situation of agro-food sector of the Republic of Moldova with the recommendations for a sustainable development

### **RESULTS AND DISCUSSIONS**

The concept of sustainable development has deep roots in economic theory, but currently sustainable development can be addressed through profit growth theory. In order to shape a real theory, it is necessary to use a certain principle that will unify four economic spheres: companies and individuals' microeconomics, national state macroeconomics, economy of cross border corporations and global economy.[3]"The practical approach of the concept of sustainable development involves the use of certain important resources, which unfortunately not all countries are able to mobilize them. If developed countries can face easily the mobilization of these resources and the experienced effort is not significant,

in case of least developed countries or undeveloped countries things are more complicated.

It is easy to observe that during the analysis of the concept of sustainable development, this is basically the result of global economic integration. However, the concept of sustainable development has no meaning apart or without the contribution of international economic exchanges. At the same time, trade cannot be thought outside the parameters imposed by concept of sustainable development. It is certainly that, in the opportunity analysis of certain trade operations are definitely considered aspects related to sustainable development of the exporter country and also of the importer country. We can state, that the systemic approach of sustainable development coordination represent the only way to be followed, whereas its components, although important, is only the skeleton based on which can be developed strategies in the future. The correlations and addressing these components are very important through their interaction and their dynamics for sustainable development strategy of agro food sector.

On the global level shall be identified a moment of transformation, new long term challenges come out strong in the foreground and require view and decisive action. Global population (becoming more numerous), increasing pressure on natural resources and global warming causes a new framework of work. In Europe, aging is also an additional challenge. All these shall have profound implications on agriculture and rural areas. While global demand for food is rising, increased urbanization, rising prices on inputs, exercised pressure on water resources and increased vulnerability of crops and animals to climate changes shall limit food production. It is forecast that on the global level, demand for food shall increase with 70% till 2050, due to population becoming more numerous and due to increased incomes. Developed countries shall contribute mostly to this trend; their demand for food shall double in the following years. It is forecast that global population shall increase from 7 billion, as is in present to 9 billion until the middle of this

century, and 95% of this growth shall occur in least developed countries (in 50 of the least developed countries through all over the world). Increased global incomes shall be largely associated with increased urbanization (expect 70% of the world population to live in urban areas until 2050, compared to 49%, nowadays) and with a rapid economic growth in some of most popular countries (for instance, Brazil, China, India and Russia). For agro-food sector, these aspects are both an opportunity and a challenge. Growth outlooks of agro-food market are significant advantages to farmers from all over the world. However, it is expected that infrastructures of the incomplete market and socio-economic vulnerabilities of the most densely populated areas of the world shall increase food insecurity. In addition, global agricultural systems shall face increasingly with negative effects of climate changes (changing patterns of rainfall, extreme weather events, and water shortages) as well as with price volatility. On the other side, increased agricultural productivity can be achieved through investment, research and innovation, good agricultural practices and appropriate public policies. In this global context, the northern hemisphere (including Europe) shall be well positioned in order to continue the supply of global markets with many essential agro-food products.[10] The outlooks are positive, for instance, for grain production in temperate areas and for crop production in favorable areas might extend even on the north as temperatures rise. In turn, the countries of the southern hemisphere as well as those in the (sub) tropical dry areas shall probably be strongly affected by climate changes through reducing yields and increasing frequency of extreme weather events (droughts and floods). Although agriculture has always focused on agro-food security and has been a positive driver of economic growth, the company's concern for the environment in the last decades has affected agricultural policies on the global level. The desire to know where food comes from, how it was produced and if agricultural practices complies with the environment are some of today's consumer demands. On global level is registered an

increased demand for food products while the supply is relatively the same.

The Republic of Moldova, along with other Eastern European countries, is in the transition process to a market economy and European integration, which suppose significant changes in the structure of civil society, and the economy as a whole. For the Republic of Moldova the adherence to the EU shall give access to substantial funding as well as access to major markets, given the fact that 17.2% of GDP was allocated to agricultural sector, and other 41% - exports. This trend is maintained because agriculture is the only sector in the country with a positive trade balance of about 1 billion US dollars. In this case, it is inevitable to neglect a state action that tries to support this sector through certain action plans encouraging sustainable development for the Republic of Moldova on European course.[9]

National Action Plan for Moldova's adherence to the EU, National Strategy for Sustainable Development of agro-industrial complex (2008- 2015), Food Security Strategy for 2011-2015, etc., are also documents underlying resizing efforts in the field of trade with agro-food:

1.National Strategy for Sustainable Development of agro-industrial complex (2008- 2015) was an attempt to summarize the major challenges of the agricultural sector and to propose objectives and instruments for their achievement. The general purpose of the strategy is to ensure sustainable growth of the agro-industrial sector with a consequent improvement of life quality in rural areas through increasing the competitiveness and productivity of the sector. Another strategy developed by our state is "Food Security Strategy"[4];

2.Food Security Strategy for 2011-2015 is a prerequisite for adoption of EU food security principles and for achieving integrated approach "from fork to fork" in order to ensure public health and to allow export growth. This strategy has established three main objectives: (1) improving the legal framework for food safety; (2) establishing a certain national authority for food safety and (3) ensuring adequate control over food

safety.[5]

Thus, we can mention, that currently shortcomings from food security management system of the country is the most serious impediments to access the EU market and a competitive presence of Moldovan agricultural products in international markets, as well as in the context of national public health considerations. Existing institutional organization is based on a fragmented structure, with several institutions and with a number of agencies on central, municipal and district level responsible for food security.[7] Overlapping functions caused repetitive requirements related to inspections, laboratory testing, certification, etc., thus leading to increase costs for private sector and institutional confusion allowing rent seeking. Food Security Strategy and new legislation started the process of transparency and credibility of the system and are looking for necessary resources for realizing laboratory investments in order to comply with the National Strategy for Modernization the System Laboratory. Also, Border Inspection Points and other infrastructure shall require significant investment to bring them in accordance with EU requirements.

Development Strategy of Agriculture and Rural Development for 2014-2020 aims to achieve a view based on consistency between agriculture, environment and rural development, which represent economic, environmental and social problems. Strategic view: "A competitive agro-business sector shall contribute to rural areas of the Republic of Moldova to become more attractive for work and live, having the necessary infrastructure. Agriculture and rural areas shall provide goods and services and at the same time preserving biodiversity, cultural and traditional values for future generations." The main purpose of the Strategy is based on achieving synergies between economic, environmental and social fields.[9] The purpose of the Strategy: "To enhance the competitiveness of agro-food sector through a restructuring and extensive modernization and to improve life quality and work in rural areas through realizing certain synergy between agro-food activities and natural environment".

In order to achieve the nominated purpose and taking into consideration the performed analysis of agro-food sector, we identified three priorities and nine measures, namely:

1. Increasing the competitiveness of agro-food sector in the Republic of Moldova, through restructuring and modernization. The competitiveness of Moldovan agriculture is low due to several factors. Taking into consideration this reason, as well as from strategic view of the sector, is indicative that the Republic of Moldova shall increase the competitiveness of agriculture through focusing on agricultural products with high added value. In this respect, the strategy places a special emphasis on modernization of the sector, improving the education level and associated systems, as well as on facilitating access to markets for inputs and outputs.

2. Increasing investment in modernization of agro-food chain, including compliance with EU food security and quality requirements. First, it is necessary to support modernization and restructuration of farms specialized in the production of traditional agricultural products (fruits and vegetables, milk, meat) and other competitive agricultural products. Secondly, processing agro-food products, together with marketing of Moldovan products shall be supported through investments in modern technologies, in order to comply with EU standards on food security and quality requirements. Third, shall be enhanced the cooperation between farmers and agro-business representatives (wholesalers, retailers) to increase income opportunities and to provide access of Moldovan agro-food products on national and international markets.

3. Facilitating the access to capital, inputs and outputs markets for farmers. Actual investment support programs provide important tools for improving farmers' access to capital. Increased efforts to improve farmers' access to credit shall be directed to: (i) create a certain framework of functioning for secured transactions of goods (guarantee funds, certificates of deposit); (ii) dynamic land markets in order to transform the country in an asset more attractive to banks, and (iii) reduce the agricultural risks (through

mitigation effects and risk insurance in agriculture). Markets of production factors shall benefit of an open regime for the import of seeds and seedlings, as well as for products of plant protection and fertilizers, and shall help national producers to be competitive on global markets. Producers' access to outputs markets, especially problematic for small and medium producers shall be addressed by supporting the integration of farmers in supply chains, for instance through facilitating their relationship with the involved participants, including processors, but also supermarkets; through association of producers to allow, among other things, to improve access to post-harvest infrastructure, and to facilitate their access to places / facilities on the market.

Ensuring sustainable management of natural resources and products of agro-food sector

Although the Republic of Moldova has fertile soils and a favorable climate for agricultural production, it is facing with many environmental challenges described above. Therefore, a priority for the Republic of Moldova is adapting to climate changes at national and capacity consolidation. Such an approach shall include improving farmers' access to new varieties, technologies and information through farmer training; improving dissemination of weather forecasts for manufacturers, especially for extreme events; investigating options to reform the process of crops insurance in order to reduce administration costs and improving accessibility and encourage the private sector involvement in adaptation efforts to climate changes. Improving institutional capacity shall focus on identifying varieties resistant to drought and temperatures, animal breeds more tolerant on current international market for adoption in the Republic of Moldova, as well as training farmers to use water more efficiently and to make use of new information on weather forecast.

The Strategy proposes the following 3 measures in the following way, namely:

1. Supporting the practices of managing the agricultural land and water. One of the most effective ways to ensure sustainable management of natural resources in

agriculture is to use modern management practices of agricultural land and water. Support needs to use modern practices of land cultivation through agricultural land rotation and agricultural diversification. Investments in irrigation services are also of great importance, together with a better access to irrigation infrastructure and modern equipment.

2. Supporting production technologies and ecological products, including biodiversity. Another way to ensure sustainable management of agro-food products in agriculture is to provide ecological production technologies and ecological products. In this regard, ecological production shall be supported, especially that the demand for such products is growing on international markets. Supporting the production of energy crops is another way to make sustainable the agricultural production and also profitable. Moreover, low-quality agricultural land or unproductive shall be forest, in order to increase biodiversity and reduce soil erosion, simultaneously helping to conserve water resources.[6]

3. Supporting adaptation to specific climatic conditions. Sustainable management of natural resources shall also be ensured by measures of mitigation the effects of climate changes. In this regard, risk management tools shall be supported in order to reduce exposure to climate risks and negative effects of natural disasters on agricultural production and agricultural competitiveness. It is necessary to grant assistance to farmers in the promotion and adoption of relevant technologies, which will help adapting to climate changes. Moreover, supporting a certain insurance fund for farmers against natural disasters shall increase farmers' confidence and shall attract investment in new technologies.[8]

Food safety indicators show that in recent years in the Republic of Moldova the consumption level of product per capita has stabilized. However, the current consumption level is much lower than in neighboring countries or other countries in the region. In these circumstances, it is reasonable to protect domestic grain market from price volatility on international markets but also from massive

exports of grain in neighboring countries. In 2004 and 2008, administrative methods of management of grain market were practiced in the Republic of Moldova. Grain export restrictions imposed during these years to economic agents from the Republic of Moldova allowed stabilizing domestic grain market and ensuring food safety of the country.

The current situation meets much similarities with that from the years mentioned, fact that confirms the appropriateness of similar measures. Simultaneously, these administrative measures also would include certain shortcomings. Arguments against such measures may be the following:

a) reduction of farmers' income, which occurred in 2004 and 2008.

b) termination of delivery contracts of cereals and imposed respective penalties may affect the credibility of economic agents and the country's overall image.

The situation of the Republic of Moldova is characterized by continue growth of prices to energy prices, utility rates and also food products. Rising prices in neighboring countries has as consequences the increase of illegal cross-border trade with these products. In the given circumstances are necessary emergency measures on stabilizing in general the domestic market and in particular of the market for cereal products.[10]

## CONCLUSIONS

Sustainable development and ensuring food security of the country depends on the ability to develop those branches of the national economy in which the Republic of Moldova has or may have great potential for export. The economical stability of the Republic of Moldova and overcoming of profound crisis through which it passes, can be guaranteed only by developing an effective agro-food sector, ensuring competitiveness to Moldovan products on all markets, and respectively, shall contribute in raising the country's prosperity. Primary problem with which the humanity faces is to provide a certain food security at EU level. In such circumstances, a special role lays to strategies which are used

by our state for ensuring sustainable development and ensuring pure ecological food. From these reasons appears the importance of agro-food product of the Republic of Moldova as a vital priority in ensuring a certain sustainable and upward development of the economy. This priority is confirmed also by statistical data according to which 17.2% of GDP was allocated to agricultural sector, and other 41% - exports. This trend shall be maintained because agriculture is the only sector from the country with a positive trade balance of about 1 billion US dollars. The initiatives provided by the government on European course shall hopefully result, and from the implementation of the mentioned strategies that shall boost not only the development of agro-food sector, but also the national economy as a whole.

## ACKNOWLEDGEMENTS

This research was supported by a „Marie Curie International Research Staff Exchange Scheme Fellowship within the 7th European Community Framework Programme”. Acronym:EU-PREACC Grant Agreement Number:PIRSES-GA-2012-318911. Project period: 01.03.2013-28.02.2017

## REFERENCES

- [1]Bajura T., 2013, Modern macroeconomic trends of agro-food sector development of the Republic Moldova(Tendințele macroeconomice moderne privind dezvoltarea sectorului agro-alimentar al Republicii Moldova). In: Economie și Sociologie, nr.1 IEFS, ISSN 1857-4130 Ch., IEFS, p. 37-48.
- [2]Cristache Silvia Elena, 2003, Statistical calculation methods and analysis of economic efficiency in trade”. ASE Publisher, Bucharest.
- [3]Dragan Gabriela, 2004, "Backgrounds of international trade" ASE Publisher, Bucharest.
- [4]Hotărîrea Guvernului nr.282 din 11 martie 2008, Strategia națională de dezvoltare durabilă a complexului agroindustrial al Republicii Moldova(2008- 2015), Publicat: 21.03.2008 în Monitorul Oficial Nr. 57-60 art Nr: 362.
- Table 1.** [5]Hotărîrea Guvernului R.Moldova nr.747 din 03.10. 2011, Strategia în domeniul siguranței alimentelor pentru anii 2011-2015, Publicat: 14.10.2011 în Monitorul Oficial Nr. 170-175, Art Nr. 828

[6]Legea nr. 113 din 18.05.2012 cu privire la stabilirea principiilor și a cerințelor generale ale legislației privind siguranța alimentelor; Publicat: 13.07.2012 în Monitorul Oficial Nr. 143-148, Art. 467.

[7]Legea nr. 257 din 27.07.2006 privind organizarea și funcționarea piețelor produselor agricole și agroalimentare; Publicat :08.09.2006 în Monitorul Oficial Nr. 142-145, Art. 700.

[8]Legea nr. 115 din 09.06.2005 cu privire la producția agroalimentară ecologică; Publicat: 15.07.2005 în Monitorul Oficial Nr. 95-97, Art. 446. Data intrării în vigoare: 15.10.2005.

[9]Ministerul Agriculturii și Industriei Alimentare al R.Moldova, 3 iunie 2013, Strategia de Dezvoltare a Agriculturii și Mediului Rural din Moldova 2014 – 2020,<http://www.maia.gov.md/public/files/Proiecte/ProiectStrategiaAgriculturaDezvRur.pdf>

[10]Stratan Alexandru, 2007, Evolution of agriculture economy of the Republic of Moldova: reflections, problems, economic mechanisms, Chisinau: Ed.ASM, 380 p.



## THE ANALYSIS OF THE AGRO-FOOD SECTOR TRADE OF THE REPUBLIC OF MOLDOVA AND THE EUROPEAN UNION: POSSIBILITIES AND LIMITS

Tatiana DIACONU

Moldova State University, 60 Mateevici Alexe street, MD-2009, Chisinau, Republic of Moldova, phone: +373 22 57 77 75, E-mail: tatiana.diaconu@mail.ru

*Corresponding author:* tatiana.diaconu@mail.ru

### Abstract

*The paper studied the development of the agro-food sector trade in the Republic of Moldova and the European Union. Also, within this study there were identified the possibilities and limits of trade in the agro-food sector development to demonstrate the importance of agriculture for the economic development of the Republic of Moldova. To accomplish this, it was conducted an analysis during the period 2003-2013. Various research methods such as: analysis and synthesis, comparison method, induction and logical inference were used to determine the possibilities and limits to growth competitiveness and efficiency of the sector. The new opportunities of the EU market on one side (hand) and the Republic of Moldova on the other side (hand) will boost investments, stimulate the modernization of agriculture and improvement of working conditions.*

**Key words:** agro-food sector, agricultural markets, agricultural protectionism, commercial policies, food crisis

### INTRODUCTION

In any society based on production, exchange is the base of economic activity. The exchange allows a better allocation of rare resources and thus, an increase of effectiveness of the economic system. The development of exchanges accompanies the specialized process of legal entities, which gradually give up to produce all the goods they need. This rule of exchange and of specialization applies regardless nature of the production unit: individual, enterprise, region, and nation. Seen in its historical context, it shall be remarked the fact that presence of trade exchanges was made necessary from time when people began to communicate with each other.[8]

From those specified we shall mention that trade also has a strategic importance for balanced and viable development of economic and social systems of any country. In such sense, trade is one of the most important side of the modern economy, regardless its form, becoming the main element of market economy. Starting from such premises, the knowledge of this field, interpreting phenomena which are the base of exchange

documents and outlining specific management processes raises special complex for which solving needs knowledge and extensive scientific analysis within which shall be called both the vast theoretical tools provided by specialized disciplines as well as practical experience gathered during the centuries, trading being one of the oldest human occupations.[4] To all this shall be added the fact that in future, changing the exchange that shall also create important new business opportunities shall require extremely fast reactions from firms, the ability to interpret correctly the new changes and the power to influence a highly competitive market and one generating continuous restructuring. All this requires a good knowledge of commercial problems, of trade and its structures.[9]

### MATERIALS AND METHODS

The study used different methods of research, such as: method of analysis and synthesis, comparison method, the method of induction and logical inference to determine possibilities and limits to growth competitiveness and efficiency of the sector. The period analysed in

this study was 2001-2013.

## RESULTS AND DISCUSSIONS

The respective trade is a specific business sector with a high level of complexity, structured on multiple interior fields, within which the important roles are assigned to retail distribution, storage goods and supply with wholesale as well as import-export activities of a country.[10]

Currently, it is shown the fact that the condition of the national economy concerns everyone – the evolution of macroeconomic indicators in the country are followed up with maximum attention, and thus every branch of the national economy is a part of a giant mechanism which evolution must be considered that can contribute to a better or malfunction of the economy as a whole. The condition of the national economy depends mostly on trade policy through which diversification of economic relations occurs.[5]

Trade policy of the Republic of Moldova is part of economic policy aiming the sphere of foreign economic relations and assumes all

regulations, instruments and measures of commercial policy following to promote external trade exchanges and stimulate on shelter the national economy development from foreign competition.[7]

In this context, trade policy of the Republic of Moldova aims to promote external economic relations, especially by boosting exports, protecting national economy of foreign competition and by regulating and monitoring the import, as well as to maintain trade balance.

Trade of the Republic of Moldova tends to focus on the European Union. The European Union shall be the main trading strategic commercial partner of Moldova in future, whose sales market remains attractive especially for agro-food sector.[3] According to economic experts, trade with the European Union prevails both exports and imports. For this, we propose to analysis the possibilities of commercial exchanges of the Republic of Moldova on the agro-food sector, as well as its limitations on the European market, given the fact that agriculture is and shall remain the branch that has a vital importance for local population.[6]

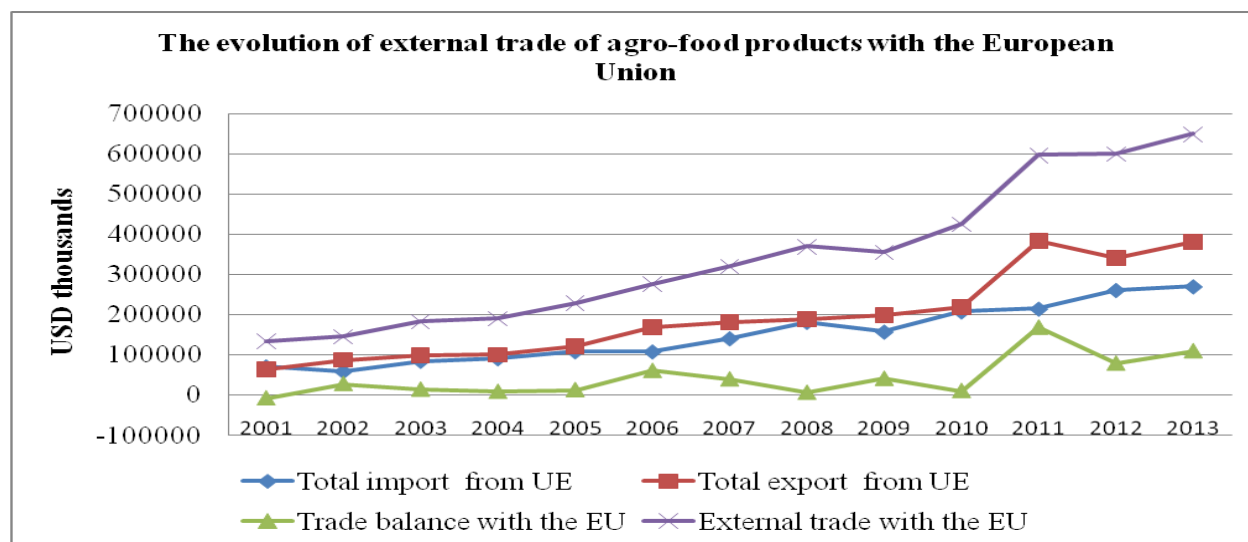

Fig. 1. The evolution of external trade of agro-food products with the European Union

Source :Elaborated by the author based on data of the National Bureau of Statistics of the Republic of Moldova

Based on the data presented in Fig. 1, during the analyzed period, the value of foreign trade of agro-food products of the Republic of Moldova with the European Union registered an upward growth in 2013 compared to 2001,

approximately 4.9 times. On this upward trend, a negative influence had the global crisis in 2009, which led to a decrease of Moldova's foreign trade with the European Union. Thus, if in 2008, foreign trade was

USD thousand 368, 851, then at the end of the year 2009 decreased up to USD thousand 354,791.2.[2]

The foreign trade increase has been influenced mostly by the export increase of agro-food products than of imports, with rates slightly higher exceeding imports with agro-food products. Analyzing exports of agro-food products we observe that in 2013, their real value was USD thousand 379,516.1 and has increased compared to 2001 with approximately USD thousand 317,090.7. Negative trends are observed in 2012, when exports decreased from previous year with USD thousand 42,777.5. This decrease in exports is explained by the fact that, 2012 was marked by a severe drought affecting almost all the territory of the Republic of Moldova. Its effects were manifested by reducing or damaging crops in the north and south region, thus giving priority to imports of agro-food

products. Therefore, the evolutions of the Republic of Moldova's imports from the European Union register a trend of increased imports from USD thousand 69,980.5 in 2001 to USD thousand 269,779.1 in 2013, or more with 3.9 times. During this upward trend were registered small oscillations, especially in 2009, when imports decreased compared to previous year with USD thousand 24,448.7. Also, the reduction in imports is observed in 2006 but with some insignificant oscillations. So, after the performed analysis, we observe that the growth rate of exports exceeds the growth rate of imports and led to an increase of certain positive trade balance of the Republic of Moldova with the European Union generating a positive balance during the analyzed period from USD thousands 28,073 in 2002 to USD thousand 109,737 in 2013, or more 3.9 times.[1]

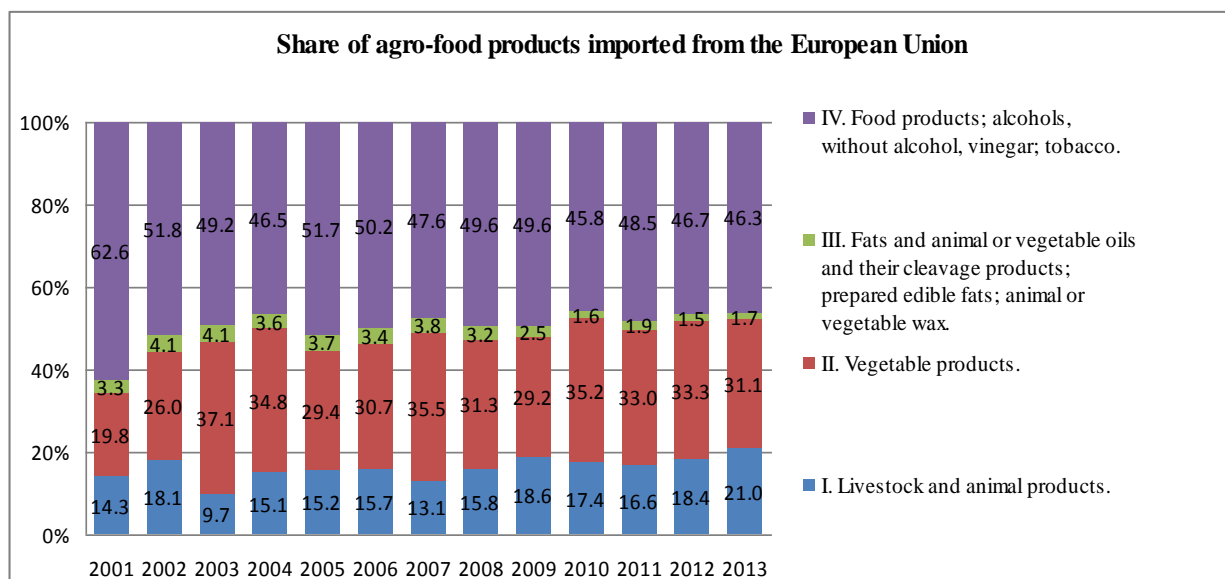

Fig. 2. Evolution of imports share of agro-food products from the European Union

Source:Elaborated by the author based on the National Statistic Bureau of the Republic of Moldova

During the years 2001-2013, examining the import of agro-food products from the European Union, we observe light changes in their structure on groups of goods: namely, we can find out that the Republic of Moldova has imported more and more agro-food products (alcohols, without alcohol vinegar, tobacco), their weight being primary, but also decreasing from 62.6% in 2001 to 46.3% in 2013 with some deviations

in 2005, when imports of agro-food products has increased compared to 2004 with about 5.2 percentage points. Increases are observed also in 2011 compared to the same period of the previous year with 2.7 percentage points. Light changes are observed also in the category: "Vegetable products". Although, this trend plays a certain pessimism note, however it was observed that imports from the given

category register an upward trend, but also an oscillatory one, increasing by about 11.3 percentage points in 2013 compared to 2001. Also, the “Animal products” represent 21% of total volume of imports of agro-food products from the European Union, having a value of USD thousands 56,233.1 in 2013, being increased by 6.7 percentage points compared to the same period of 2001. In the structure of imports of agro-food products for the period 2001 to 2013, the most

insignificant share went to section “Fats and animal or vegetable oils and their cleavage products; (prepared edible fats; animal or vegetable wax)”, registering a value of USD thousands 44, 435. 4 thousand USA in 2013, representing 1.7% of total imports of agro-food products from the European Union. We shall mention that the share of imported products in this section decreased compared to the same period of year 2001 by about 1.6%. [1]

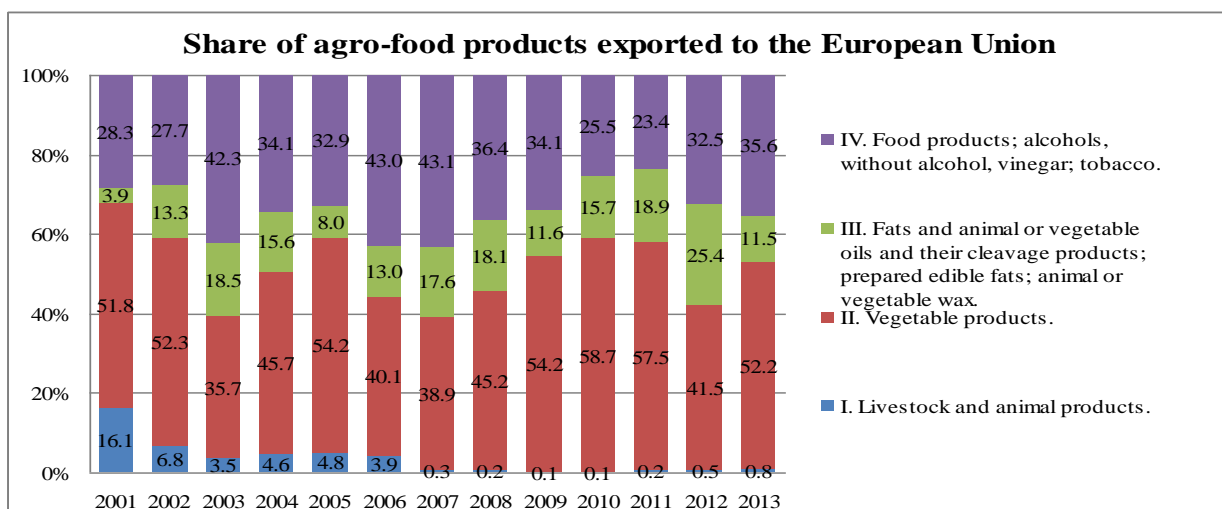

Fig. 3. The contribution of export share of agro-food products destined for the European Union Source:Elaborated by the author based on the National Statistic Bureau of the Republic of Moldova

During the analyzed years, the export of agro-food products performed by the legal entities of the Republic of Moldova with the European Union registered an upward trend with approximately 6.07 times in 2013 compared to the same period of 2001. The structure of agro-food products in export resulted from agricultural activities, the main share went to goods of the section “Vegetable products” registering a share of 52.2% of the total exports of agro-food products destined for the European Union in 2013, ie more with 0.04% compared to 2001. Goods of the section “Food products; alcohol, without alcohol vinegar; tobacco” making up 35.6% of total exports of agro-food products destined for the European Union represents a value of USD thousands 134,951.2 in 2013. It shall be mentioned that, the share of exported products of this section has seen a substantial increase of 7.3% compared to the same period

of 2001. Moldova exported to the European Union and animal products (Fats and animal or vegetable oils and their cleavage products; prepared edible fats; animal or vegetable wax) that worth thousands USD in 2013, or 7.6% more compared to the same period of 2001. Also, were exported livestock and animal products that worth thousands USA representing 0.8% in 2013 of total exports of agro-food products in the European Union less than the similar period of 2001 when exports of this section were 16.1%. [1] Analyzing the coverage level of imports through exports of agro-food products with the European Union during all the analyzed period, we observe that exports with the European Union ensured imports with 141.73% in 2013 to 89.20% in 2001, which implies that the Republic of Moldova export more to the European Union countries than try to import.

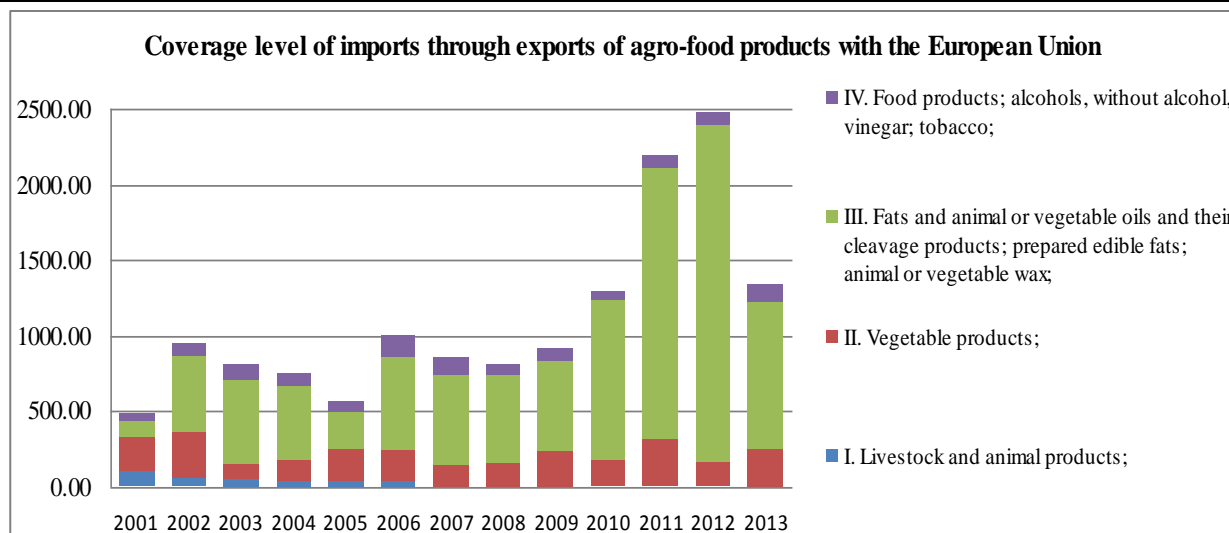

Fig. 4. Evolution of the coverage level of imports through exports of agro-food products with the European Union  
 Source:Elaborated by the author based on the National Statistic Bureau of the Republic of Moldova

Positive trade balance is influenced by the coverage level of imports through exports of products of section “Fats and animal or vegetable oils”, registering an increase of 105.70% in 2001 to 981.09% in 2013. The analysis of evolution of coverage level of imports through exports in the reference period 2013 reveals that, compared to the same period in 2001 have been registered increases by about 5.4% also to products of the section “Vegetal products”.[2]

A wider view on the evolution of external trade of the Republic of Moldova with products of section “Food; alcohols, without alcohols vinegar; tobacco” highlights the dominant trend of increased imports with a higher intensity than exports of this category. During the years 2001-2012, the considerable gap in the evolution of exports and imports of “Food; alcohols, without alcohols vinegar, tobacco” determine the accumulation of a certain deficit of trade balance in amount of USD thousands 15,7. The largest deficit of trade balance of agro-food products with the European Union was registered with products of the category "Livestock and animal products”.

Regarding unfavorable evolution of this trend on external trade with products of this section: “Livestock and animal products” also indicates the coverage level of imports through exports, which from 2002, no longer meets the minimum limits, continuously

decreasing from 57.38% in 2002 to 5.12% in 2013.

## CONCLUSIONS

From those stated, we shall mention that trade has a strategic importance also for balanced and viable development of economic and social systems of any country. In the condition of market economy, in order to regulate the export - import relation, the necessity to achieve certain activities by the state is indisputable.

Therefore, regulating by the state the trade has a conclusive impact on the development of export - import relations, state using for these purposes a large variety of means and methods of influence against trade in such way to be able to enter on a new market.

Regarding the Moldovan producers, they are able to sell more on the European Union market, fact demonstrated also by the performed analysis, where exports of agro-food products designed for the European Union registered increases during the analyzed period. Thus in 2013, their actual value was USD thousands 379,516.1 and increased compared to 2001 with approximately USD thousands 317,090.7. The imports of agro-food products from the European Union also register an upward trend from USD thousands 69,980.5 in 2001 to USD thousands 269,779.1 in 2013, or more

with 3.9 times.

Thus, the growth rate of export exceeds the growth rate of imports and led to an increase of certain positive trade balance of the Republic of Moldova with the European Union, generating a positive balance during the analyzed period from USD thousands 28,073 in 2002 to USD thousands 109,737 in 2013, or more with 3.9 times. The most popular agro-food products on the European market, according to the performed analysis are the goods of the section "Vegetable products" which register the main share of 52.2% in 2013, of the total exports of agro-food products, ie with 0.04% more than in 2001.

So, following to the performed analysis we can state that the Republic of Moldova has the possibility to achieve agro-food products on the European market, but in future need to intensify efforts on other sections, which are part of the agro-food sector and have a lower share to export to the EU market.

## ACKNOWLEDGEMENTS

This research was supported by the „Marie Curie International Research Staff Exchange Scheme Fellowship within the 7th European Community Framework Programme”. Acronym:EU-PREACC Grant Agreement Number:PIRSES-GA-2012-318911. Project period: 01.03.2013-28.02.2017

## REFERENCES

- [1]Anuarul statistic al Republicii Moldova, Статистический ежегодник Республики Молдова.: 2013, 556 p, Chişinău, Ed. Statistica,.
- [2]Biroul Naţional de Statistică al R. Moldova, 2013, Comerţul exterior al Republicii Moldova. Chişinău:Ed. Statistica.
- [3]Centrul Analitic Independent „Expert-Grup” [accesat 15 ianuarie 2015]. Disponibil: [www.expert-grup.org](http://www.expert-grup.org)
- [4]Condrea Elena, 2014, The sustainable development of the agro food market, Ediţia a XII-a. Nr.1 / 2014, Chişinău, Editura ASEM, p.108-116.
- [5]Coşer Cornel, 2014, Evaluarea infrastructurii competitivităţii exportului agro-alimentar al R.Moldova, N.2, Ed.INCE al AŞM, Chisinau, p. 116-126
- [6]Dodu-Gugea Larisa, 2012, Determinarea tendinţelor

viitoare ale dezvoltării comerţului exterior al Republicii Moldova cu ţările UE, Ed. ASEM, Chişinău, p.108-114.

[7]Litvin Aurelia, 2014, Management of promotion the export of agro-food product (the case of the Republic of Moldova), PhD thesis, Chisinau UASM.

[8]Patriche Dumitru, Stanescu Ion, Grigorescu Mihai, Felea, A., Toma Sorin, 1999, Bazele comerţului, Bucuresti, Editura Economica, 366 p.

[9]Miron, D., 2005, Politici comerciale, Bucureşti, Ed. Luceafărul, 284 p.

[10]USAID Program of Trading for Private Farmer, 2004, Study Competitiveness of Moldovan Agrarian Exports of High Value, Trigraf-printing,. Chisinau, pp. 544

## THE ROLE OF GROUND RENT IN ESTABLISHING THE AGRICULTURAL LAND PRICE

**Ramona DOBRE**

Bucharest University of Economic Studies, 6 Piata Romana, District 1, Bucharest 010371, Romania, Phone: +4 021 319 1900, Romania, Email: ramonadobre88@yahoo.com

*Corresponding author:* ramonadobre88@yahoo.com

### *Abstract*

*The present paper aims to demonstrate the role that ground rent has in establishing the agricultural land price. In order to be able to prove the connection between the ground rent and the agricultural land price, there are submitted to debate indicators that are part of ground rent such as the positioning of the land, the distance between the land and the access roads and water source, the intrinsic qualities of the land soil, the type of land and the manner of exploitation. The debate is intended to show how and in what manner the indicators part of ground rent may influence the price of an agricultural land. The final purpose of this study is to prove that a justified land price may contribute to encourage the agricultural land transactions and therefore to develop the land market. To fulfil the purpose of this paper it is necessary to understand what land ground means, why it is important the land price and how can the agricultural land price influence the agricultural land market and the development of the agriculture overall. The main methods utilized are collecting, analyze and interpreting data and information from the specialized literature. The conclusions formulated at the end of the study allow seeing the influence of ground rent on agricultural land price, the influence of the agricultural land price on agricultural land market and the influence of agricultural land market on the development of the agriculture.*

**Key words:** *agricultural land price, development, ground rent, land market*

### INTRODUCTION

The importance of establishing the agricultural land value is given by the necessity to fix a right and equitable price of the agricultural land. A right price encourages the land market transactions and furthermore helps at developing the agriculture overall. The necessity to establish the agricultural land value in a state such as Romania, which is characterized by an excessive fragmentation, gets a particular importance. The ground rent, due to its components, may prove as a very useful instrument in establishing the agricultural land value. It is very important to establish a reasonable price for the land both for the owners and buyers. It also helps to protect the owners because the agricultural land owners are suffering a loss when the value of their property decreases. [6]

To understand the role of the land owner it is essential to establish the legal limits. Proprietary right is that subjective right of appropriation which gives expression to a good as allowing the owner to possess, use, and dispose of that property in its own power and self-interest and in compliance with existing legislation. [1]

### MATERIALS AND METHODS

In order to highlight the role that ground rent has in establishing the price of the land, it is described the concept of land, its specificity and the ground rent components. The agricultural land is analysed separately according to its use. Also, a comparison between the category of use in Romania and UE 27 is made in order to establish the similarities and differences able to help prove that the components of the ground rent are useful in establishing the land rent. The material of the present paper is collected, analysed and interpreted from speciality studies. The statistical data are collected from the EUROSTAT for the period 2005-2010. [9]

### RESULTS AND DISCUSSIONS

The notion of land is found in the definition of land fund through Law no. 18 of 19 February 1991, also called Land Law, republished in the Official Gazette no. 1/5 January 1998 which states that land of all kinds, regardless of destination, the title under which are owned



or private or public domain they belong, is the land use in Romania. [5]

According to the Explicative Dictionary the land is defined as expanse of land area (considered by relief or by its location in space). [4]

Land, in his acceptance of Rogoz Chiva is a free good, which by its characteristics is manifested in two forms:

- Free running condition of production in agriculture, forestry, fisheries, aquaculture, construction, shipping, etc., hypostasis in which is expressed by the notion of fixed capital (means of labor);

- Raw material, labor object of some agricultural and non-agricultural activities, and is identified with the concept of capital. [2]

### ***Agricultural land***

According to the definition included in the Law 18/1991 agricultural lands are those lands that make part in the agricultural circuit. These lands are those which are differentiated in the urbanism plan and there are found both in intravilan and extravilan. These lands include:

- productive agricultural land that refers to arable land, vineyards, orchards, vineyard and fruit nurseries, hops and mulberry plantation, greenhouses and solariums, pastures and hayfields and other similar plantation;

- agricultural land with forestry vegetation which refers to forested pastures that are not part of the arrangements of forestry;

- lands occupied by constructions and agrozootechnical installations, fishery facilities, land improvements, technological and agricultural exploitation roads, platforms, warehouse and storage places which aimed at serving the needs of agricultural production

- unused lands that can be landscaped and used for agricultural production;

The mode of use of agricultural land

Depending on the mode of use the land with agricultural destination can be classified:

- Arable land - is the area that is plowed every year or once every several years and is cultivated with annual or perennial plants.

- Pasture – represent land that is completely covered with herbaceous vegetation, installed or naturally regenerated, by seeding, destined

for grazing animals.

- Meadows – represent land covered with grass vegetation, installed or naturally regenerated by seeding, destined to harvesting for the production of hay.

- Vineyards and vine nurseries - are areas with vineyards, nurseries and land preparing for vineyards.

- Orchards and tree nurseries - is the surface occupied with orchards and land preparing for orchards.

At European Union level the following types of land are met:

- Arable land which include cereal crops for the production of grain (including seed), protein crops for the production of grain, industrial crops (tobacco, cotton, soybeans, sunflowers, hops, rape, hemp, other oilseeds, in, herbs medicinal and other plants), fresh vegetables, ornamental plants and flowers (protected by law and inaccessible, cultivated and accessible, fodder plants), other arable crops, uncultivated land.

- Kitchen garden [9]

- Permanent pasture and meadow

- Permanent crops (fruits and shrubs of temperate and subtropical climates, nuts, citrus, olive groves for oil or table)

Vineyards and nurseries (vineyards for obtaining quality wine and another type of wine, grapes and raisins)

- Other permanent crops

- Other types of land which includes unused agricultural land (agricultural land which is no longer used for economic or social purpose, which are not used in the crop rotation system), wooded area and other land (land occupied by buildings, annexes of farms, roads, ponds, land with infertile soils or rocks).

Land use in the European Union is very diverse and depends on climatic zones, geography and culture. Regarding climate zones, land use together with different soil fertility and even once with tradition and culture existing in EU Member States.

### ***Evolution of agricultural land according to the category of use***

Agricultural land is different depending on its category of use. Each category of use has a different economic value. The economic value



of the land may be used in establishing the land price. This signifies an equitable trade for both buyer and seller.

Table 1. Agricultural land according to the category of use in Romania

		Romania	
		Surface (thousand ha)	Share in total surface
Utilized	2005	14,815.2	100
Agricultural Area	2007	14,709.3	100
	2010	13,298.0	100
Arable land	2005	9,335.4	63.01
	2007	9,423.3	64.06
	2010	8,305.0	62.45
Kitchen garden	2005	-	-
	2007	-	-
	2010	182.0	1.37
Pasture and meadow	2005	4,812.1	32.48
	2007	4,861.4	33.05
	2010	4,494.0	33.79
Vineyards and nursery	2005	667.5	4.51
	2007	424.6	2.89
	2010	317.0	2.39

Source: www.europa.eu

Table 2. Agricultural land according to the category of use in EU 27

		EU 27	
		Surface (thousand ha)	Share in total surface
Utilized	2005	171,996.200	100
Agricultural Area	2007	172,485.050	100
	2010	172,194.350	100
Arable land	2005	103,599.680	60.21
	2007	103,281.990	59.88
	2010	103,691.230	60.22
Kitchen garden	2005	425.810	0.25
	2007	390.430	0.23
	2010	359.450	0.21
Pasture and meadow	2005	55,970.020	32.54
	2007	55,175.150	32.17
	2010	55,558.110	32.26
Vineyards and nursery	2005	11,178.630	6.50
	2007	10,839.710	6.28
	2010	10,928.290	63.46

Source: www.europa.eu

Regarding agricultural area both at EU 27 and Romania level during the analyzed period 2005-2010 is observed a reduction of it. This fact has meant changes in the structure of the land fund depending on the category of use. Beside the physical diminution of the occupied surface depending on the category of use it can be observed modifications regarding the structure of the land fund.

Agricultural area ranges from 14,815,200 hectares in 2007 and 13,298.0 thousand hectares in 2010 in Romania. To this change in downward, bring their contribution surfaces decreases in all categories of use. In the case of vineyards and orchards is observed a decrease with approximately 50% in 2010 compared to 2005. This is explained by the nature of permanent crops involving

regeneration in a longer period of time compared to the other categories of use.

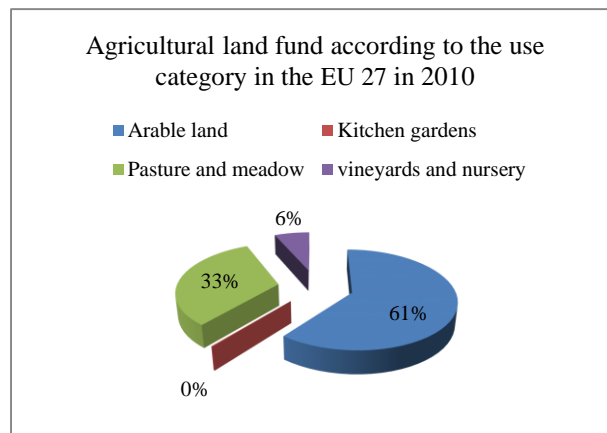

Fig.1. Category of land use EU 27

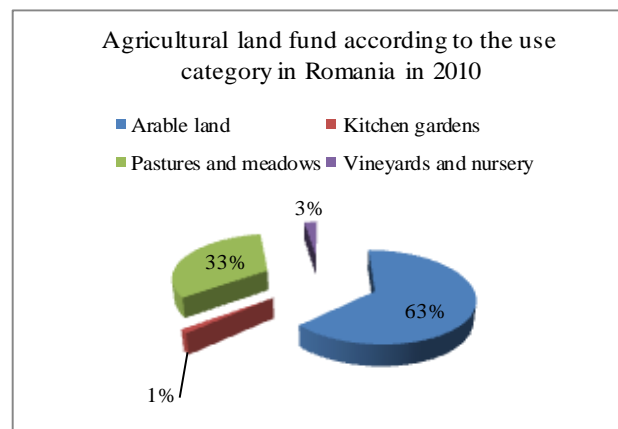

Fig.2. Category of land use Romania, 2010

The graphic representations highlight the fact that structures regarding the agricultural land fund are similar. Therefore, both in Romania and EU 27 the largest share is held by the arable land with approximately 60 percent of the utilized agricultural area. The second category as share is represented by pastures and meadows with approximately 33 percent in Romania and 33 percent in EU. A percent of 6 for EU 27 and of 3 for Romania is held by vineyards and nurseries. Kitchen garden hold the lowest share, about 0.27 percent in EU 27 and 1.37 in Romania. In the period 2005-2007, in Romania, the kitchen gardens were not included in the structure of the agricultural land fund due to the too small surfaces they held.

Also, in the analysed period 2005-2010 it can be observed that even if the share is oscillating the agricultural land fund remains

the same; there are not registered important changes neither for EU 27 nor Romania.

#### ***Differentiation of the agricultural land according to the property structure***

Another kind of highlights the land fund structures is differentiation by property structure. Both in Romania and in EU land may be the subject of public property or private property.

Starting with the year 1990, the changes that occurred in the Romanian society by the collapse of land belonging to the former totalitarian socialist state properties have been the subject property as follows:

- Domain of national interest of the country
- Public domain of local interest
- State's private domain. [7]

Private domain consists of property owned by private individuals or legal entities, goods which, irrespective of ownership, are used to produce income and cannot be alienated. [8]

#### ***Agricultural land specificities***

The agricultural land, same as other types of lands is characterized directly through the territory and ground specificities. Agricultural land is the only stock of which price cannot be established starting from its costs, because this cost does not exist as in the case of other stocks that can be produced these particularities has an important influence on land exploitation and therefore on the obtained results.

***Land particularities*** are as follows:

***-Spatial limitation.*** This particularity is drawn by the limitation bounds imposed naturally, by its own dimensions, which make that agricultural land to be impossible to multiply or replicate as necessary. However, it can be discussed a reduced possibility to increase the agricultural potential (by draining, for example), under the circumstances of progressively reducing the agricultural land due to removal from the agricultural circuit of large areas of land as a result of soil degradation or due to the change of destination use.

***Immobile character.*** The land represents a mean of agricultural production and this fact implies consequences on organizing the production process and requires not only a immobility of others production means but

also a specific utilization, depending on land types. In order to increase the fertility and economic quality it can be discuss about cropping system and crop rotations.

***Unlimited productive potential.*** This particularity imposes a rational use of land in the purpose of practicing some correct agricultural system which are adapted to each type of soil and in this manner the production potential of the land is not consumed and the effects are felt at the level of the increasing the production capacity. An incorrect utilization of the land leads to a progressive exhaustion which reduces the regenerating capacity and has serious implication over the land productivity potential by diminishing the energy and nutritive, organic or mineral accumulated in the soil substance reserves

***Requirement to invest the land with labour force (human or mechanical).*** In order to obtain material goods, beside the utilization value with which it came along, are added mechanical, chemical and biological means work by the instrumentally of labor force that acts on it. The degree of development and improvement of production means, the qualification of labor force which acts on land determines the quality and level of obtained results and efficiency.

***Impossibility to replace or substitute*** represents a particularity because if in the case of others production factors it can be discussed the substitution or replacement, in the case of the land it is known the fact that it is the only one who cannot be changed, produced or multiplied. Therefore in order to fulfil the population necessity it is imposed as primordial condition the preservations and rational utilization of the agricultural land.

***Difference of fertility.*** As consequence of the production process the results may be different. These variations are influenced by a number of factors which targets the natural potential and fertility degree. By the clear defining of the different categories of land, according to their effective capacity of production, on which it is act with correct stimulation means better results can be obtained

***Legal personality.*** This characteristic defines land as a mean through which specific

relations and phenomena can be generated. Therefore, land is considered by legal point of view subject of law, object of property and object of agricultural exploitation.

***Elements of ground rent that influence the agricultural land value***

In order to understand the changes in the real value of the agricultural land the following elements must be considered:

- The distance from the main road
- The distance from the water source
- Plot surface
- Plot *arrondissement*
- Soil quality and fertility
- Climatic specificity of the region on which the land is positioned
- Utilization and prior results

*The distance from the access road.* The importance of considering the distance from the access road is given by the facility of exploitation of the land and at the same time reducing the exploitation cost. It is obvious that a land situated at a shorter distance from the access road supposes lower expenses regarding the transportation. This fact marks a higher value of the land and therefore the lands situated in the proximity of the access road have a higher price than the ones situated at a longer distance

*The distance from the water source.* Considering the specificity of the agriculture and its dependency towards the environmental factors, especially the water, it is necessary to explore the irrigation possibilities of the agricultural land in order to obtain the best results from the exploitation of the land. Therefore, an agricultural land situated at a shorter distance from the water source has a higher value due to the cost required to constructing the irrigation system, which are lower in the case of those situated at a shorter distance. The higher price of the land situated to a shorter distance from the water source is justified by the higher value of the agricultural land given by its exploitation facilitation.

*Parcel area.* The importance of this element in establishing the agricultural land value is highlighted by the ulterior exploit possibility. On one side, a larger area of land may signify a higher value due to the fixed costs, which are increasing with the decrease of the

surface. But, a larger surface demands a higher price which obligates to the verification of the potential buyers availability to pay that amount of money for the entire surface and considering the decrease price to sell / lease the entire surface.

*The *arrondissement* of the parcel.* This element refers to the land found in the proximity of the parcel for who it's established the value. A parcel situated near lands with similar characteristics offers the possibility of extension in time. Also, if the parcel is found at a reduced distance from the intravilan it is taken into consideration the possibility of transforming the land from extravilan in intravilan.

*Qualities and fertility of the soil.* The qualities of the soil represent an element of great importance worth to consider in order to establishing the land value due to its influence on the results obtained in agriculture. The fertility of the soil has a higher influence regarding the yields. Also, a higher level of soil fertility implies the reducing of cost with artificial fertilizers.

At the European Union level there are found the following quality of soil class:

Class I: arable land suitable for intensive cultivation where other means of sustaining a high level of production are minimal or absent;

Class II: ordinary arable crops of grain, but who are not suitable for continuous cultivation. It has a large capacity support to agriculture but due to edaphic (soil factors) or environment conditions are reduced the production levels.

Class III: land suitable for grazing and land improvements. These lands can be cultivated or planted pastures wheel. The overall level of output is moderate due to edaphic and environmental constraints such as erosion risk, soil structural breakdown or other factors, including climate. These constraints may limit the ability cultivation and soil conservation. In these lands cases drainage works may be required.

Class IV: land suitable for grazing but not for cultivation. Agriculture in this case is based on native pastures or improved by respecting some minimum soil works techniques.

Production can be seasonal but production levels are decreased due to important environmental constraints.

Class V: land unsuitable for agriculture or more suitable for weak pasture. The agricultural production is very low or zero due to the severe constraints, including economic factors that impede land arrangements.

An additional class that can be used occasionally is the one in which the land has specific characteristics that allow the cultivation of particular species (bananas and other tropical horticultural crops).

Class specialist: land which due to the combination of soil, climate and other features is most appropriate to intensive production or which are suitable for narrow category of crops whose special needs require such a soil culture. This class includes soils that are described as unique.

Classification in quality classes requires knowledge of soil quality and helps determine what crops shall be practice and technologies that are to be applied.

*Specificity climate of the region in which the agricultural land is located.* Another factor in establishing the value of agricultural land is the climate of the region in which agricultural land is located. Specificity of agriculture, and more specifically its dependence on climatic factors gives a particularly importance to this element in establishing the value of the land area. So a land located in a region whose climatic factors are favorable for practicing agriculture gets a value higher than a land located in a region whose climate factors are less favorable. Explanation from the economic point of view, in this case is explained by the reduction of operating expenses, for example in an area with heavy rain irrigation are less necessary than in an arid zone, consequently lowering the cost of irrigation.

*Utilization and previous results.* In order to determine the fair value of agricultural land, another important element to consider is the use and results of previous exploitation. Thus, an exploiter can identify potential exploitation opportunities and simultaneously can have a clear vision on how to use the land in question in order to obtain the better results. The

previous results also reflects a subjective side, the results being correlated to the manner in which the exploiter choose has chosen to use his land according to his level of experience and knowledge gained from training in this regard. Due to the evolution of the national economy overall a higher interest should be designated to this indicator. Agricultural production has not been outstanding as a result of what happened in 2000-2008 by reduction in agricultural employment and then its increase by seasonal labor in response to crisis events. [3]

## CONCLUSIONS

The elements of ground rent have an important contribution to establishing the value of the land. The elements of the ground rent have a major influence on the results obtained from exploiting the agricultural land and this is the main reason why it becomes so important. A correct value of the land helps to formulate a fair price attractive for the buyer and profitable for the seller. This supports the land market transaction and furthermore the development of the agriculture and rural space overall. The importance of knowing the elements of ground rent that helps to establish the land value is highlighted by the fact that through them can also be discovered a series of opportunities for obtaining better results and also helps to identify the threats and makes easier to find solution for the problems caused by the threats.

The role of ground rent in establishing the value of the land is essential in a country such as Romania characterized by an excessive fragmentation of the agricultural land.

## REFERENCES

- [1]Chelaru E., 2000, Curs de drept civil. Drepturi reale principale, All Beck Publishing;
- [2]Chiva Rogoz, 2006, "Capital Land-theoretical boundaries and meaning ", International Conference Complex developing of the countryside - Volume I, diversification of economic activities in rural areas and increase the competitiveness of agriculture, ASE, Bucharest, 23-24June 2006 page 555
- [3]Dachin, A., 2011, Contribuții ale agriculturii la fluctuațiile economice în România. Economie teoretică

și aplicată, Volumul XVIII, No. 1(554), pp. 154-165

[4]Explicative Dictionary

[5]Law no. 18/1991 – Land Law 19th February 1991

[6]OECD 2008, Soutien à l'agriculture, valeur des actifs fonciers et ajustement sectoriel: Conséquences pour la réforme, OECD Publishing.

[7]Pop, L., 2001, Dreptul de proprietate Și dezmembrămintele sale, Lumina Lex Publishing;

[8]Scrieciuc, F., 2001, Tratat teoretic și practic de drept funciar, Vol. I, Lumina Lex Publishing.

[9]www.europa.eu



## MANUFACTURING AND PERFORMANCE EVALUATION OF A COMPATIBLE UNIT TO PRODUCE ANIMAL FEED PELLETS

Tarek FOUDA, Adel ELMETWALLI, O. KADDOUR, Asaad DERBALA,  
K. ABDEL-MOHSEN

Tanta university, Faculty of agriculture, Egypt, Phone: +20403455584, Fax: +20403455570,  
Mobile: +20128476266, Emails: tfouda @yahoo.com, adelra99@yahoo.com,  
derbalana@yahoo.com

*Corresponding author:* tfouda @yahoo.com

### Abstract

*The main objective of this research was to manufacture and evaluate a compatible unit including mixing and pelleting to produce Rabbit feed pellets formula in one operation. The compatible was evaluated under operating parameters including four different retention time (2, 3.5, 4 and 5min) and four L/D ratio (5:1 5.5:1, 6:1 and 6.5:1) were investigated under the above mentioned parameters. The optimum results compatible unit were die L/D ratio of 5.5:1, 3.5min of mixing retention time, and rollers teeth width of 10mm. 427.87kg/h production rate 37.96 kW.h/ton energy requirement. 88.29% mixing efficiency, 0.671gm /cm<sup>3</sup> bulk density, 93.21% durability, 49.01N hardness, and 566.36 LE/ton using residues formulation including black seed meal.*

*Key words:* evaluate, compatible unit, manufacture, pelleting

### INTRODUCTION

Rabbit production has potential in developing countries as a mean of supplying cheap high quality animal protein within the shortest possible time. Animal feed produce errs take always care about pellet quality which is affected by many factors. Pellets quality fundamentally affects the profitability of the product and this mainly depends on mixing and pelting process one considered on important to improve the pellet specification such as bulk density, durability, hardness and lowering costs and getting high quality in the same time.

Agricultural residues represent an extreme problem in Egypt facing the people and state with economic, environmental and healthy aspects. The annual amount of crop residues is almost 25-35 million tons.

Pelleting is considered to have an important role in animal performance. It is very useful in materials handling since it improves the specifications of the material. It increases bulk density and prevents the segregation of different ingredients. It is therefore very important to testify different parameters affecting pellet mill machines and choose the optimum operating conditions.

the Indian Grassland and fodder Research Institute (IGFI) developed an animal feed pelleting machine for making feed pellets from poultry droppings. The size of the pellets varies from 8mm to 38mm in diameter and from 20 to 60 mm in length depending upon the need of different animals[3].

Hardness results at different temperatures. Temperature is believed to affect quality but hardness results appear to be random. In another trial hardness had a negative correlation to durability.

This is rare but it can occur. It appeared that molasses was added at variable levels during the pelleting run.

Addition of molasses can make the pellet soft and gummy; it may even be possible to bend the pellet. Soft pellets can be very durable, making the hardness test an inappropriate method of measuring quality [5].

Specific rows of die holes, such as the two interior and outside rows, also sometimes are counter bored to greater depths to encourage feed flow through these outer rows of holes to help dies wear more evenly[1].

Limited the operating conditions which affect the quality of pellets feed as follows: pellet die thickness as related to diameter of hole, speed of ration should be also considered for each die

thickens/hole diameter combination[1].

Geometrical dimensions of die holes reference is the most important factor influencing extruder machine efficiency and pellets quality. Producing 12mm diameter high quality of large animal feed pellets rely on the ration components attributes, for that, the high quality extruded pellets made from residues need different die hole specification comparing with that made from standard components. Results show that the optimum machine efficiency appraised by machine productivity, energy requirements and total losses and appraised for pellets quality by pellets[4].

Quality of the final pellets depends on the process before the die (milling and mixing), Pelleting conditions and the process after the die (drying and cooling).For the pellet milling process, there is a general agreement on the contribution of different factors on the durability of feed pellets. The relative role of diet formulation is reported to be 40%, while that of particle size, steam conditioning, die specifications and cooling/drying are 20, 20, 15 and 5%, respectively. When including an expander in the conditioning process, the distribution becomes 25, 15, 40, 15 and 5%, respectively, for diet formulation, particle size, steam and expander conditioning, die specifications, and cooling/drying [6].

The objectives:

of this manufacture of a compatible unit to produce Rabbit feed pellets from black seed meal residues.

Optimizing operating parameters (Retention time, L/D ratio, Rollers speed , and Rollers teeth affecting the performance of manufacture compatible unit.

## MATERIALS AND METHODS

Compatible unit to produce Rabbit feed pellets was manufactured in Zagazig city and evaluated at the institute of Agricultural engineering. Giza, Cairo.

A rabbit experimental ration was used in the present study; it has composition as shown in table 1.

The raw material was prepared to dropped under the hopper. The material is mixed by Water in conditioner (auger) - the mixture is

pressed by the rollers inside the die holes – the pellets exits from the die.

Table 1.Composition of the experimental ration

Stander formula		Residues formula	
ingredients)	Percentage	ingredients	Percentage
Barley grains	19.20	Barley grains	19.20
Wheat bran	28.50	Wheat bran	28.50
Clover hay	30.90	Clover hay	30.90
Soybean meal	5.00	Black seed meal	14.13
Corn grain	11.7	Corn grain	2.57
Molasses	3.00	Molasses	3.00
Limestone	1.00	Limestone	1.00
Sodium chloride	0.25	Sodium chloride	0.25
Premix	0.30	Premix	0.30
DL Methionine	0.15	DL Methionine	0.15
TOTAL	100%	TOTAL	100%

Technical specifications of the Compatible unit Machine:

The Compatible unit base was made from L shape steel sections, having dimension of 1314 mm length, 750 mm width and 980 mm height as shown in Fig (1).

### Forming unit (Die)

The flat die is considered the most important part in disk pellet mill machines. It is responsible to form the Mach to pellets with the required diameter. The die material was made from a very hard steel C52 having dimensions of 440 mm outer diameter, 50 mm inner diameter and 32 mm thickness as illustrated in Fig (2).

### The compressing unit (Rollers)

The compressing unit was responsible to compress and form the mach to pellets through the die holes.

It consists of two rollers, fabricated from hard steel and constructed by conical bearings on two horizontal bars which fixed on a central iron block.

The compressing unit was constructed on the top of main moving shaft passing through the center of fixed die machine. Each roller is cylindrical in shape. The rollers cam base has dimensions of 225 mm outer diameter, 50 mm inner diameter and 90 mm width. The rotating motion of the rollers was stable around the horizontal bars which were yielded from the main shaft rotating motion.

A 0.5 mm clearance between the die and the rollers extended according to the motion of the rollers around the horizontal bars for agreement with capacity of row materials to force pressing through the die holes as shown in Fig. (3).



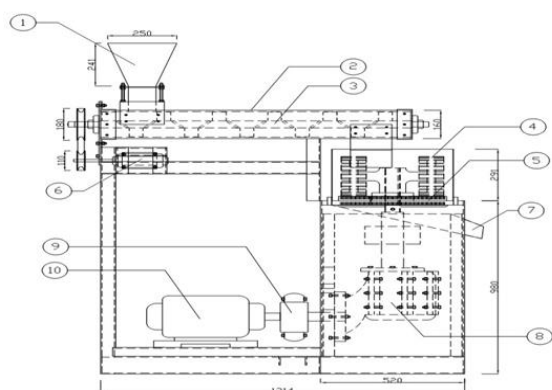

NO	Part Of Name	NO	Part Of Name
1	Feeding unit	6	Motor conditioner shaft
2	Pre-conditioner	7	Gat output product
3	conditioner shaft	8	Gear box
4	Compressing rollers	9	Coupling
5	Forming die	10	Main motor

Fig.1. Elevation of view the Compatible unit showing different parts.

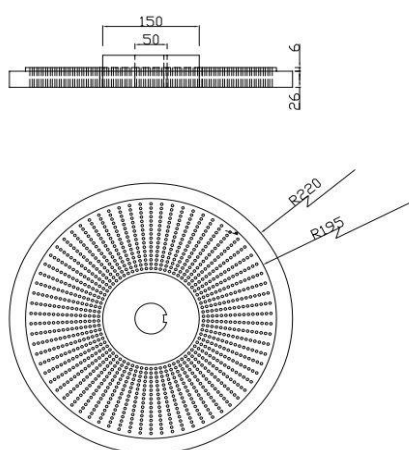

Fig. 2. Forming unit (Die)

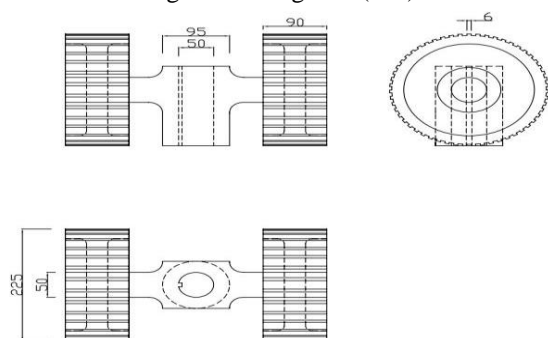

Fig. 3. Elevation, plan, and side view of compressing unit (Rollers).

### Methods:

#### Processing Parameters.

These two parameters were investigated using rollers teeth width of 10 mm to choose the optimum operating conditions to produce new

rabbit formula. Using a digital tachometer (Cole-Parmer 8204-00, kit-Japan) was used for measuring the rotating speed of the main shaft.

#### Evaluation of a Compatible unit efficiency and product quality.

Rabbit formula was produced by a local Compatible unit using dies with 4mm diameter circular openings. The Compatible unit performance was evaluated for Compatible unit efficiency and pellets quality based on the following measurements:

1. Pellet a Compatible unit productivity which was measured for each treatment by taking a sample for 2 min. At the beginning, the machine was operated for 10 mm to reach the steady condition before collecting samples.

2. Specific mechanical energy (SME), was calculated using the following equation:

#### Energy requirement

Energy requirement in kW.h/ton was calculated using the following equation:

$$\text{Energy consumed} = \frac{P}{Q} = \text{kW.h/ton}$$

Where:

**I** = Line current strength in amperes.

**P** = consumed power for mixing ration, kW.

**Q** = Machinery line productivity, ton/h.

$$\text{Total consumed power, (kW)} = \frac{\sqrt{3} I V \eta \cos \theta}{1000}$$

Where:

**I** = Line current strength in amperes.

**V** = Potential difference (Voltage) being equal to 380 V.

**Cos θ** = Power factor (being equal to 0.84).

**η** = Mechanical efficiency (assumed 90 %).

## RESULTS AND DISCUSSIONS

### 1. Compatible unit Productivity

Besides formulation, formula moisture content and particle size, die and rolls specifications are the most important measurements affecting flat die mill machine productivity.

Fig. 4 depicts the effects of die L/D ratio on the pellet mill machine productivity at different retention times.

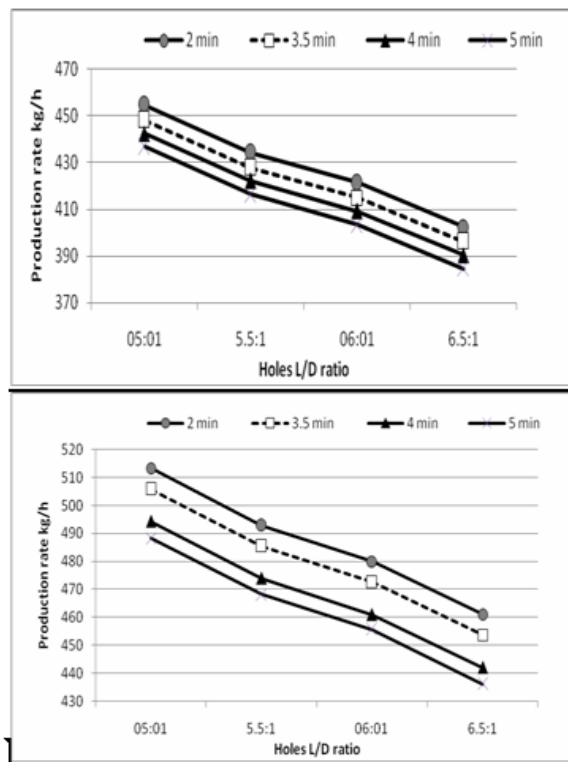

Fig. 4. Effect of die L/D ratio on productivity using rollers teeth width of 10 mm at different pre-conditioner retention time.

It is obvious that increasing the die L/D ratio from 5:1 to 6.5:1 decreased the mill machine productivity at all used retention times. increasing die L/D ratio from 5:1 to 5.5:1, 6:1 and 6.5:1 decreased the pellet mill production from 454.67 to 434.29, 421.4 and 402.56 kg/h at 2 min pre-conditioner time; from 448.25 to 427.87, 414.98 and 396.14 kg/h at 3.5 min; from 442.48 to 422.1, 409.21, and 390.37 kg/h at 4 min, and from 436.7 to 416.32, 403.43 and 384.59 kg/h at 5 min. these results were recorded with the residues formula.

The results obtained with the standard formula had the same trend since increasing die L/D ratio from 5:1 to 5.5:1, 6:1 and 6.5:1 decreased the pellet mill production by 19, 10, 11 and 11% at 2, 3.5, 4 and 5 min retention times respectively.

The decrease in flat die production rate by increasing the mixing retention time from 2 to 3.5, 4 and 5 min could be due to the decrease in pre conditioner shaft speed that lead to decrease the pellet mill feeding mass.

Also, the decrease in pellet mill production rate by increasing the die L/D ratio from 5:1 to 6.5:1 could be due to the increase in

formula retention time inside the die holes that lead to decrease the product output in time unit.

## 2. Specific mechanical energy (SME)

Energy requirements are very important in economical analysis for any industrial operation.

Fig. 5 illustrates the effect of die L/D ratio on energy requirements at different retention time.

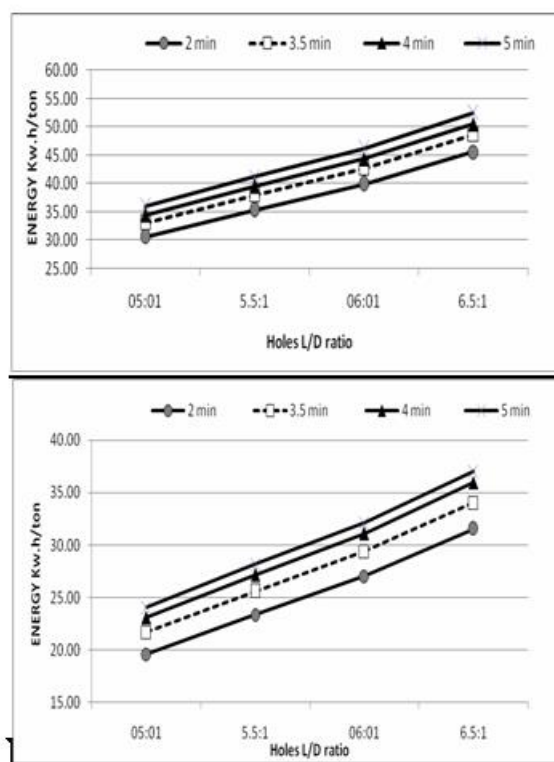

Fig. 5. Effect of die L/D ratio on energy requirements using rollers teeth width of 10 mm at different pre-conditioner retention time.

It is indicated that increasing die L/D ratio from 5:1 to 6.5:1 increased the consumed power at all retention times. The results demonstrated that increasing die L/D ratio from 5:1 to 5.5:1, 6:1 and 6.5:1 increased specific mechanical energy from 30.53 to 35.30, 39.84 and 45.58 kW.h/ton at 2 min pre-conditioner time; from 32.99 to 37.96, 42.65 and 48.62 kW.h /ton at 3.5 min; from 34.44 to 39.54, 44.35, and 50.49 kW.h /ton at 4 min and from 35.97 to 41.22, 46.15 and 52.47 kW.h /ton at 5 min retention time. Same results were obtained with standard formula as with increasing L/D ratio from 5:1 to 6.5:1 increased the consumed power by 61, 57, 55

and 53% at 2, 3.5, 4 and 5 min retention times respectively. Increasing specific energy by increasing die L/D ratio may have been a result of increasing power consumed and decreasing the pellet mill productivity.

### 3. Mixing efficiency

Fig. 6 depicts the relationship between L/D ratio and mixing efficiency showing that increasing die L/D ratio from 5:1 to 5.5:1, 6:1 and 6.5:1 increased the mixing efficiency from 85.14 to 85.65, 85.77 and 85.82 % at 2 min pre-conditioner time; from 87.76 to 88.29, 88.4 and 88.43 % , at 3.5 min pre-conditioner time; from 90.95 to 91.48 , 91.59 , and 91.62 % at 4 min and from 88.76 to 89.29 , 89.39 and 89.45 % and at 5 min pre-conditioner time.

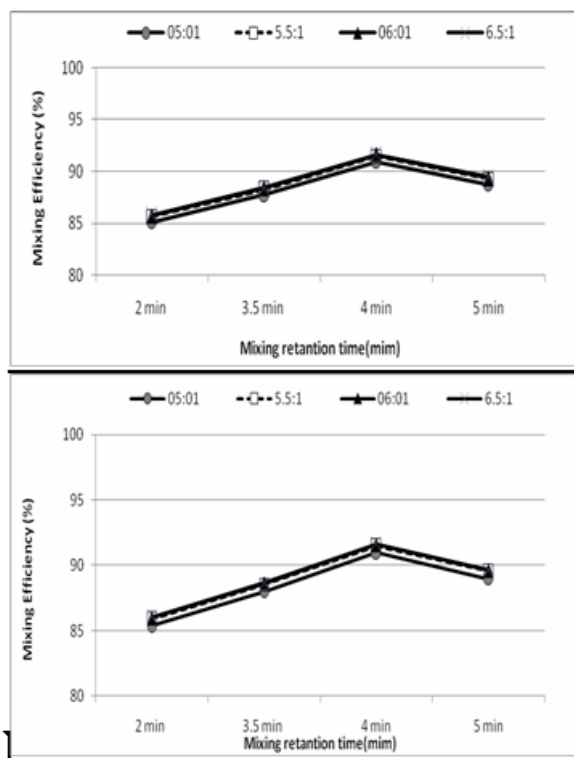

Fig.6. Effect pre-conditioner retention time on mixing Efficiency using rollers teeth width of 10 mm.

Same results were obtained with standard formula as with increasing L/D ratio from 5:1 to 6.5:1 increased the mixing efficiency by (0.8, 0.7, 0.8 and 0.7%)% at 2, 3.5, 4 and 5 min retention times respectively. increasing The mixing efficiency by increasing the mixing retention time from 2 to 4 minutes could be due to The Homogeneity of ingredients mixture components. Also,

decreasing The mixing efficiency by increasing the mixing retention time from 4 to 5 minutes could be due to the scattering ingredients formula and decreasing The Homogeneity of mixture components.

### 4. Pellets bulk density

Pellets bulk density is one of the most important targets of any feed manufacturing industry. The results presented in Fig.7 showed that increasing die L/D ratio of 5:1 the pre-conditioner retention time increasing from 2min to 3.5 min the bulck density increasing from 0.593 to 0.624 g/cm<sup>3</sup> but it decreased to 0.579 , 0.56 g/cm<sup>3</sup> at the pre-conditioner retention time of 4, 5 min, using die L/D ratio of 5.5:1 the pre-conditioner retention time increasing from 2min to 3.5 min the bulck density increasing from 0.64 to 0.671 g/cm<sup>3</sup> but it decreased to 0.627, 0.607 g/cm<sup>3</sup> at the pre-conditioner retention time of 4 and 5 min, using die L/D ratio of 6:1 the pre-conditioner retention time increasing from 2min to 3.5 min the bulck density increasing from 0.684 to 0.715 g/cm<sup>3</sup> but it decreased to 0.671, 0.649 g/cm<sup>3</sup> at the pre-conditioner retention time of 4,5 min, using die L/D ratio of 6.5:1 the pre-conditioner retention time increasing from 2min to 3.5 min the bulck density increasing from 0.771 to 0.805 g/cm<sup>3</sup> but it decreased to 0.761, 0.741 g/cm<sup>3</sup> at the pre-conditioner retention time of 4 and 5 min, Same results were obtained with standard formula as with increasing L/D ratio from 5:1 to 6.5:1 increased the bulk density by 30, 28, 26 and 28 % at 2, 3.5, 4 and 5 min retention times respectively. Increasing the bulk density by increasing the die L/D ratio from 5 :1 to 6.5 :1 could be due to the increasing of pressing time inside the die holes and increasing the compressing of mixture particles accordingly. the pellets mass increased by increasing the pressing time. . Also, increasing the bulk density by increasing the retention time from 2 to 3.5 minutes could be due to the homogenous of mixture particles meanwhile the decreasing the pellets bulk density by increasing retention time from 3.5 to 5 minutes could be due to scattering formula.

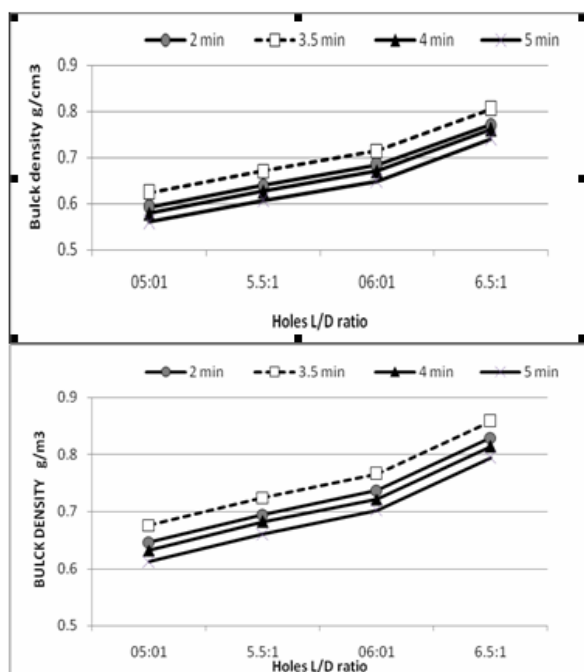

Fig. 7. Effect die L/D ratio, on bulk density using rollers teeth width of 10 mm at different pre-conditioner retention time.

### 5. Pellets durability

Die L/D ratio mainly the most parameter affecting pellets durability. Regarding the collected data showed in Fig. 8, it indicated that using die L/D ratio of 5:1 the pre-conditioner retention time increasing from 2 min to 3.5 min the pellets durability increasing from 88.3 to 90.72 % but it decreased to 87.97, 85.41 % at the pre-conditioner retention time of 4, 5 min respectively, using die L/D ratio of 5.5:1 the pre-conditioner retention time increasing from 2min to 3.5 min the pellets durability increasing from 90.79 to 93.21 % but it decreased to 90.46, 87.9 % at the pre-conditioner retention time of 4, 5 min respectively, using die L/D ratio of 6:1 the pre-conditioner retention time increasing from 2min to 3.5 min the pellets durability increasing from 91.97 to 94.39 % but it decreased to 91.64, 89.08 % at the pre-conditioner retention time of 4, 5 min respectively, using die L/D ratio of 6.5:1 the pre-conditioner retention time increasing from 2min to 3.5 min the pellets durability increasing from 94.53 to 96.95 % but it decreased to 94.2, 91.64 % at the pre-

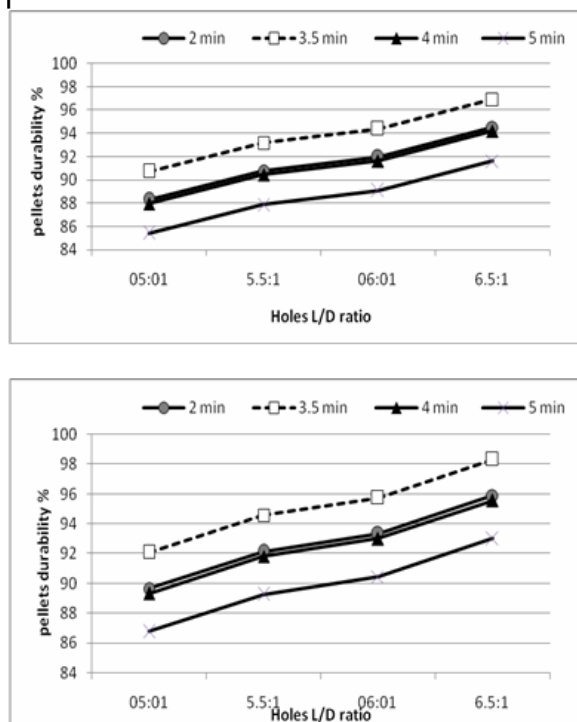

Fig. 8. Effect die L/D ratio, on pellets durability using rollers teeth width of 10 mm at different pre-conditioner retention time.

conditioner retention time of 4, 5 min respectively, under using rollers teeth of 10 mm, residues formula.

The same results were obtained with standard formula as with increasing L/D ratio from 5:1 to 6.5:1 increased the pellets durability by 7, 7, 8 and 7 % at 2, 3.5, 4 and 5 min retention times respectively, increasing the pellets durability by increasing the die L/D ratio from 5 :1 to 6.5:1, increasing the pressing time inside the die holes could be due to the increasing of pellets mass and decreasing the pores inside the pellets.

Also, increasing the pellets durability by increasing the retention time from 2 to 3.5 minutes could be due to increasing the pellets bulk density and decreasing the pores inside the pellets. meanwhile the decreasing the pellets durability by increasing the retention time from 3.5 to 5 minutes could be due to the decreasing of pellets durability and increasing the pores inside the pellets.

### 6. Pellets hardness

The data showed in Fig. 9 indicated that using die L/D ratio of 5:1 the pre-conditioner retention time increasing from 2min to 3.5 min the pellets hardness increasing from 45.3 to



46.84 N but it decreased to 44.06 , 43.86 N at the pre-conditioner retention time of 4, 5 min respectively.

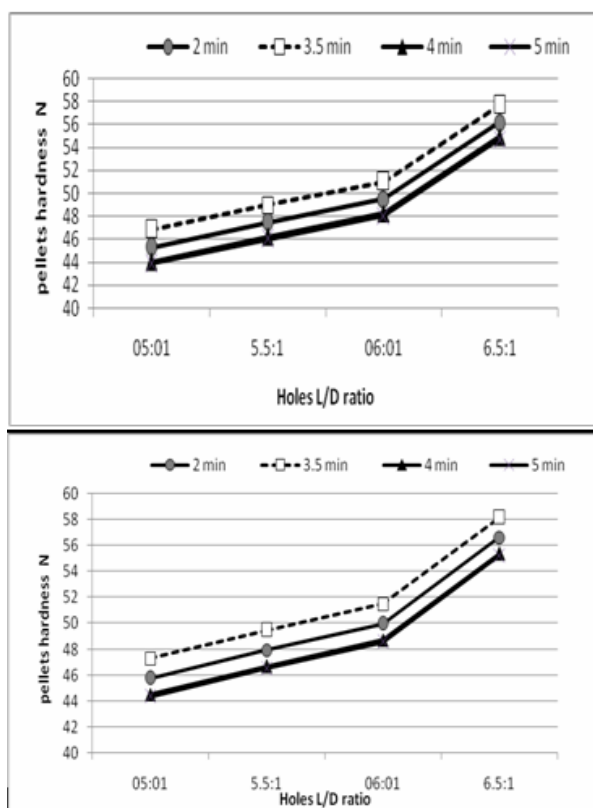

Fig.9. Effect die L/D ratio, on pellets hardness using rollers teeth width of 10 mm at different pre-conditioner retention time.

Using die L/D ratio of 5.5:1 the pre-conditioner retention time increased from 2min to 3.5 min the pellets hardness increasing from 47.47 to 49.01 N, but it decreased to 46.23, 46.03 N at the pre-conditioner retention time of 4,5 min respectively, using die L/D ratio of 6:1 the pre-conditioner retention time increasing from 2min to 3.5 min the pellets hardness increasing from 49.5 to 51.04 N but it decreased to 48.26, 48.06 N at the pre-conditioner retention time of 4,5 min respectively, using die L/D ratio of 6.5:1 the pre-conditioner retention time increasing from 2 min to 3.5 min the pellets hardness increasing from 56.16 to 57.7 N but it decreased to 54.92, 54.72 N at the pre-conditioner retention time of 4,5 min respectively, under rollers teeth width of 10 mm using residues formula.

The same results were obtained with standard

formula as with increasing L/D ratio from 5:1 to 6.5:1 increased the pellets hardness by 24, 24, 22 and 24 % at 2, 3.5, 4 and 5 min retention times respectively.

Increasing the pellets hardness by increasing the die L/D ratio from 5:1 to 6.5:1, could be due to the increasing the pellets bulk density according to the increasing the pressing time inside the die holes. Also, increasing the pellets hardness by increasing of the homogenous of mixture particles meanwhile the decreasing the pellets hardness by increasing the retention time from 3 to 5 minutes could be due to a low homogenous of mixture particles.

### 7. Cost of rabbit pellets unit mass

It is very important to know what is the advantage of manufacture a simple unit of flat die pelleting machine and use some of residues formulation including black seed meal in rabbits formula economically.

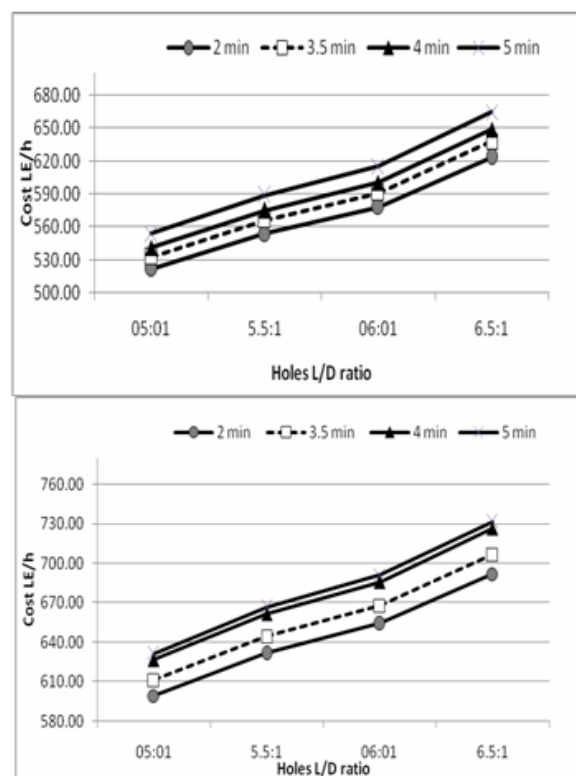

Fig.10. Effect die L/D ratio, on cost using rollers teeth width of 10 mm at different pre-conditioner retention time.

Regarding for collected data showed in Fig. 10, it indicated that increasing the pre-conditioner retention time from 2min to 3.5, 4 and 5 min increasing the cost from 521.85 to

532.96, 541.22 and 553.90 LE/h using die L/D ratio of 5:1, from 554.24 to 566.36, 575.48 and 589.26 LE/h using die L/D ratio of 5.5:1, from 578.12 to 590.99, 600.74 and 615.32 LE/h using die L/D ratio of 6:1, from 623.83 to 638.06, 648.97, and 664.99 LE/h using die L/D ratio of 6.5:1.

The same results were obtained with standard formula as with increasing L/D ratio from 5:1 to 6.5:1 increased the cost by 15, 15, 16 and 15 % at 2, 3.5, 4 and 5 min retention times respectively.

The minimum operation cost of (521.85 L.E. /ton), (599.26 L.E. /ton) was obtained by using the constructed machine at mixing retention time of 2 minute, die L/D ration of 5:1 and of pressing rollers teeth width of 10 mm for residues and stander formula recipitavily.

## CONCLUSIONS

The important results obtained may be summarized in the following recommendations:

The preferred die L/D ratio is 5.5:1 for achieving high machine efficiency and pellets quality.

The preferred pre-conditioner retention time is 3.5 min for high machine efficiency and pellets quality.

The preferred rollers teeth width is 10 mm for the flat die pellet mill.

## REFERENCES

- [1]David, A.F., 2003, "Pelleting for profit-part2. National Grain and feed association. Feed and feeding digest", Vol, 54, No. 7, December 22.
- [2]Hasting, W.H., 2003, Feed milling process. Mt. Vernon, Washington D. Higgs Enviroment Canda, Van cover, British Columbia.
- [3]Gupata, P.D., Goyal, R.K., 1999, Pillarization of different animal feeds using IGFRI pelleting machine - an analysis of feeding trial Processing Equipment and Technology, Vol. 20, Issue 1, pp 70-77.
- [4]Kaddour, U.A., Ewes, T.A., Afify M.K., 2006, Influences of Geometrical dimension of extrusion die holes on machine efficiency and pellets quality. 4th annual conference of J. Agric. Sci., Mansoura Univ., 2006, 31 (7): 337-358.
- [5]Mchinney, L.J., Skinner, D.O., Nable, R.G, Teeter, A., 2001, Pellet quality effects on Broiler growth and efficiency. Animal science research report, Oklahoma

Agricultural Experiment Station, Division of Agricultural Science and Natural Resources, Oklahoma state Univ. August 2001: 1086.

[6]Van, T., Vliet, A.F.B., Van der Pole, 2008, The Effects of the diet ingredients and their composition on production characteristics of pellets and their physical quality. Animal Feed Science and Technology, Volume 70, Issues 1–2, January 1998, Pages 5.

## MINIMIZE ENERGY AND COSTS REQUIREMENT OF WEEDING AND FERTILIZING PROCESS FOR FIBER CROPS IN SMALL FARMS

Tarek FOUDA, Adel ELMETWALLI, Samier SHALABY, Amina ALBEBANY

Tanta University, Faculty of agriculture, Egypt, Phone:+2122876266, Fax: +20403455570,  
E-mails:tfouda@yahoo.com, adelra99@yahoo.com, amena2015@yahoo.com

*Corresponding author:* tfouda@yahoo.com

### Abstract

*The experimental work was carried out through agricultural summer season of 2014 at the experimental farm of Gemmiza Research Station, Gharbiya governorate to minimize energy and costs in weeding and fertilizing processes for fiber crops (Kenaf and Roselle) in small farms. The manufactured multipurpose unit performance was studied as a function of change in machine forward speed (2.2, 2.8, 3.4 and 4 Km/h) fertilizing rates (30,45 and 60 Kg.N.fed<sup>-1</sup>), and constant soil moisture content was 20%(d.b) in average. Performance of the manufactured machine was evaluated in terms of fuel consumption, power and energy requirements, effective field capacity, theoretical field capacity, field efficiency, and operational costs as a machine measurements. The experiment results revealed that the manufactured machine decreased energy and increased effective field capacity and efficiency under the following conditions: -machine forward speed 2.2Kmlh. -moisture content average 20%.*

**Key words:** fertilization, fiber crops, minimize energy, small farms weeding

### INTRODUCTION

Fiber crops like Kenaf (*Hibiscus cannabinus*) and Roselle. (*Hibiscus Sabdariffa*) are of the most economic crops in the world. It produces a good fiber which used for making many agricultural and industrial applications like paper pulp, thermoplastics, fishing nets, ropes and doormats. Oil produced by the plants is used for first-class cooking oil and margarine production. These two species belong to the family Malvaceae. Chemical fertilizer application for fiber crops is very important while Nitrogen is essential for cell enlargement and deviation of cell at faster rate. Phosphor helps in paper root development. Potassium important in inducing drought tolerance in crops. [2].physical properties of Roselle seed cultivated in Egypt in clinding (length, width, thickness moisture content ,mass of 1000-Kernels ,volume , percent of sphericity, geometric diameter, arithmetic diameter and bulk density ).He found that (length, width and thickness of the seeds was ( 5.40, 3.02, 11.39, and 4.10) mm, respectively . He showed that 1000 seed mass was 40g respectively; the sphericity was 71.61.The bulk density was .86 Kgm<sup>-3</sup> respectively. [4]

developed a 5.4 kW diesel engine operated power weeder for weeding and intercultural in sugarcane crop. The machine was capable of weeding 1 ha/day. Sufficient soil mulch was produced for better crop growth. The effective field capacity and weeding efficiency was observed to be 0.082 ha/h and 96% respectively [5]. Kenaf fertilization was applied in two doses. The first was applied at sowing as basal dressing with 50 kg N ha<sup>-1</sup>, 50 kg P ha<sup>-1</sup> and 50 kg K ha<sup>-1</sup> in all plots, except N0 plots in which only P and K fertilization was applied. The second dose was applied on the onset vegetative phase, when plant height was approximately at50 cm [6] evaluated a self-propelled, engine operated power weeder, which has a diesel engine of 3.8 hp (3600 rpm), as a power source. The weeder has L-shaped blades. This weeder was found to be suitable for weeding in wider row crops like maize, cotton, sugarcane etc. The moisture content of the soil at the time of evaluation was 17-18 %. The depth of operation ranged from 4-7 cm (avg. 6.8 cm). The machine was operated at an average forward speed of 1.64 km/h. The weeding efficiency of 88% was obtained with the machine. At the time of weeding minor injuries to cotton plants (1.84%) were

observed but these injuries are recoverable type [7] Weeding, thinning and hoeing are three major intercultural operations attempted in fiber crops. Among these weeding takes nearly 25-30% of the total cost of production. If the weeding is not done at proper time, whole crop is adversely affected. The Roselle plant have a greatest medical important it is useful in arteriosclerosis. Reported to be antiseptic, astringent, cholagogue, demulcent, digestive, emollient, purgative, refrigerant, stomachic, and tonic, Roselle is a folk remedy for abscesses, bilious conditions, cancer, cough, debility, dyspepsia, dysuria, fever, hangover, heart ailments, hypertension, neurosis, scurvy, and strangury.

## MATERIALS AND METHODS

Experiment was carried out through Summer season of 2014 at the experimental farm Research Station, Gemmiza; Gharbiya governorate Egypt .to Manufacturing weeding and fertilizing unit mounted on walking tractor to suit small farms .

Optimize some different parameters affecting the performance of double acting unit .And minimize energy and cost requirements.

Table 1. Some soil characteristics of the experimental soil.

Soil texture	Bulk Density gm/cm <sup>3</sup>	Porosity	pH	Ec dsm-1	NPK, p.p.m		
					N	P	K
Clay	1.17	55.849	7.5	2.1	59	10.1	273

## 1. Materials

### 1.1. Fiber crops

Tow types of fiber crops were used in this study, Roselle (*Hibiscuses Sabdariffa*) variety Egyptian Roselle and Kenaf(*Hibiscus Cannabinus*) variety Giza3.

Table 2. Physical properties of Kenaf and Roselle seeds.

Physical properties	Kenaf seeds	Roselle seeds
Length, mm	4.12	4.24
Width, mm	2.58	3
Thickness, mm	1.44	1.06
Volume, mm <sup>3</sup>	15.306	13.48
Mass of 1,000 seeds, g	20	21.5
Bulk density mg/mm <sup>3</sup>	1.3	1.59

**1.2. The power source.** Four strokes- diesel engine Walking tractor-SH151-1 of(11.03kW)

was used as a power source.

### 1.3 Dual purpose unit.

A local manufactured combined cultivating and fertilizing unit for small farms consists of the following parts as shown in fig 1.

**(i)-Frame and wheels.** The main fixed frame is made of iron sheet steel. with dimensions of 150 cm length,36 cm width and 18 cm height . The frame includes elements to fix the weeding and fertilizing unit, also a hanged joint was constructed to attached the manufactured machine with the walking tractor. It was carried by tow ground wheels with 70cm diameter.

**(ii)- Weeding unit** consists of three beams and three shares every single share was fixed in one beam with the ability of changing the distance between beams and the depth of share in the soil.

**(iii)- Fertilizing unit** consists of two fertilizer hopper feed mechanism, fertilizing tubes, furrow openers and machine wheels as shown in fig 2.

**(iv)-Feeding mechanism** consists of three parts arranged from up to down as shown in Fig.4.

1-Upper disc: it has a semicircular peripheral aperture with a curved shape, the fertilizer follow from it to the following disc.2. Circular disc: it has eight cells with a trapezoidal shape .3. Down disc

**(v)-Transmission system:** the motion was transmitted from the machine wheel to the fertilizing unit through out three groups of tooth wheels; each group was six toothed wheels (14, 16,18,21,24 and 28 teeth) and was fixed together with one piece which could be used to change the speed by putting the transmission chain between group and another according to permitted speed.

**(vi)-Furrow fertilizers openers:** two furrow openers were fixed in two beams and later fixed in the main frame to facilitate the changing of distance between beam and depth of furrow fertilizer opener .

**(vii)-Covering device:** the covering device was composed of two ground wheels.

## 2. Methods

The experimental area was about 720 m<sup>2</sup> which was divided into two equal plots (360 m<sup>2</sup>) .The first plot was cultivated with Kenaf



(*Hibiscus cannabinus*) crop ,Varity Giza3 with row spacing 60 cm and distance between seeds in the same row 10 cm. while the second plot was cultivated with Roselle (*Hibiscus Sabdariffa*) crop, Varity Egyptian Roselle with row spacing 60 cm and distance between seeds in the same row 10 cm.

**2.1. Experimental condition.**

Field experiment was carried out to find the effect of four different parameters on the manufactured machine performance mainly:

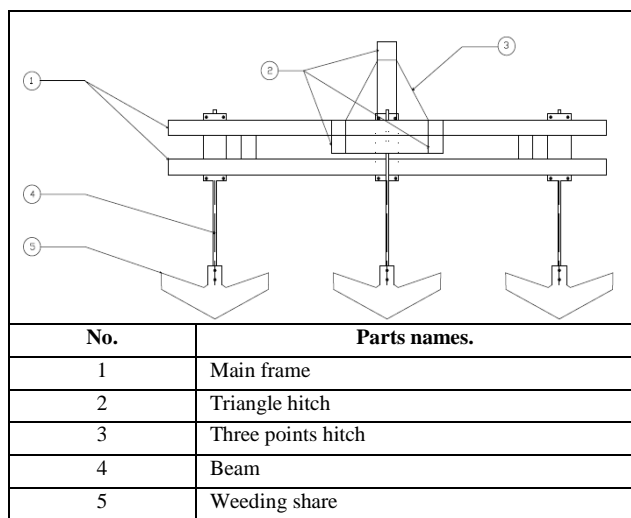

Fig . 1. The manufactured weeding unit.

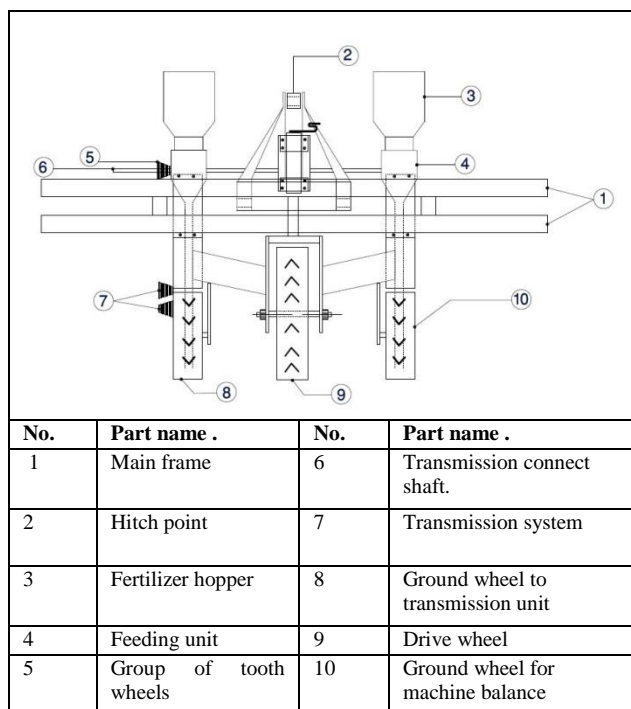

Fig . 2. The manufactured fertilizing unit.

1.Four different machine forward speeds (2.2, 2.8, 3.4 and 4 Km/h).

2.Three fertilizing rates (30, 45, and 60 Kg.N.fed<sup>-1</sup>).

3.Three different plant population (20, 30, and 40 plant/m<sup>2</sup>).

4.Tow types of fiber crops Roselle and Kenaf plant.

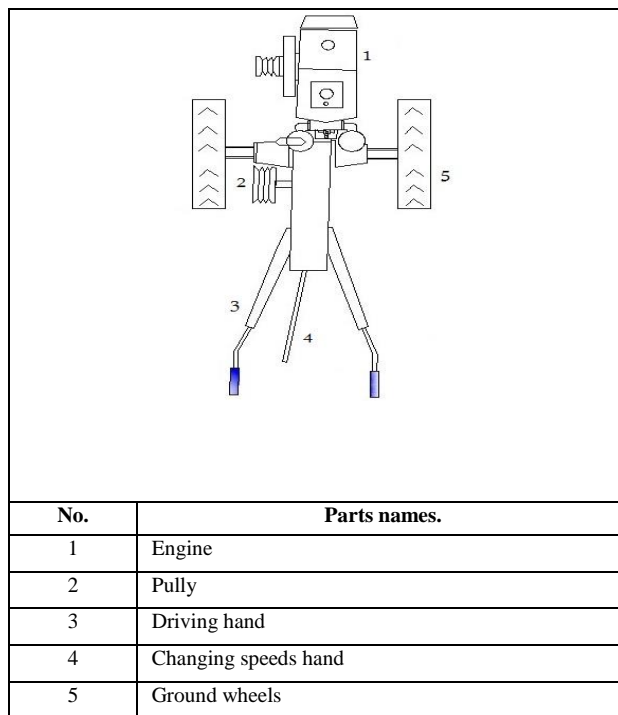

Fig .3.The walking tractor machine

**2.2. Measurements and determinations.**

**-Fuel consumption**

$$\text{Fuel consumption} = \frac{\text{Fuel consumption, ml.}}{\text{Time, sec.}} \times 3.6, \text{ L/h}$$

**-Field efficiency**

The theoretical field capacity was calculated by using the following: formula:

$$Tfc = \frac{V \times W}{4.2} \text{ fed/h.}$$

Where: Tfc = Theoretical field capacity, fed, V = Average implement forward speeds, km/h; and W = The working width of implement, m

The Effective field capacity (Efc) was determined as follows:

$$Efc = \frac{1}{T} , \text{ fed/h}$$

Where: Efc = effective field capacity, fed/h, and T = The total time.

Field efficiency is the ratio of effective field capacity to theoretical field capacity and it gives an indication of the time lost in field and the failure to utilize the full working width of the machine. The field efficiency (ηf) was

calculated by using the following formula:

$$\eta_f = \frac{E_{fc}}{T_{fc}} \times 100, \%$$

Where:  $\eta_f$  = Field efficiency, %,  $E_{fc}$  = Effective field capacity, fed/h, and  $T_{fc}$  = Theoretical field capacity, fed/h.

**-Power requirements:** the required power was calculated by using the following formula: [3]

$$EP = Fc \times \left(\frac{1}{3600}\right) \rho_f \times L.C.V \times 427 \times \frac{1}{75} \times \frac{1}{1.36} \eta_{th} \times \eta_m, (kW)$$

Where:  $Fc$  = Fuel consumption, l/h,  $\rho_f$  = Density of the fuel (0.73kg/l for gasoline fuel), L.C.V. = Lower calorific value of fuel (11030 k cal /kg for gasoline fuel), 427 = Thermo – mechanical equivalent, kg.m/k cal,  $\eta_{th}$  = Thermal efficiency of engine (35% for diesel engine), and  $\eta_m$  = Mechanical efficiency of engine (80% for diesel engine).

**-Energy requirements:** The energy requirements was calculated as follows:

$$\text{Energy requirements, kW.h / fed.} = \frac{\text{Required power, kW}}{\text{Effective field capacity, fed / h}}$$

**- Operational cost:**

The operating cost required for the fertilizing operation was estimated using [1] as the following:

$$C = \frac{P}{h} \left( \frac{1}{a} + \frac{i}{2} + t + r \right) + (0.9W.S.F) + \frac{m}{144}$$

Where:

$C$  = Hourly cost, L.E./h.

$P$  = Price of machine, L.E.

$a$  = Life expectancy of the machine, h.

$i$  = Interest rate/year.

$r$  = Repairs and maintenance ratio.

$T$  = Taxes, over heads ratio.

$0.9$  = Factor accounting for lubrications.

$W$  = Engine power, hp.

$S$  = Specific fuel consumption, l/hp.h.

$F$  = Fuel price, L.E./l.

$m$  = Monthly average wage, L.E.

$144$  = Reasonable estimation of monthly working hours.

**RESULTS AND DISCUSSIONS**

The discussion will cover the obtained results under the following heads.

**1.The impact of forward speed on fuel consumption.**

It is obvious that using traditional method for weeding and fertilizing, increased the fuel consumption from 5.2 L/h to 8.6 L/h by increasing the forward speed from 2.2 km/h to 4 km/h. While under using one pass method for fertilizing and weeding in one process, the fuel consumption was 3 L/h with the forward speed 2.2 km/h and increased with increasing forward speed reaching a maximum of 5.5 L/h with 4 km/h forward speed. The results therefore demonstrated that individual operations saved fuel consumption by 42.3, 44.67, 37, and 36% with forward speed of 2.2, 2.8, 3.4 and 4 km/h, respectively. Linear regression analysis was run to derive equations to predict fuel consumption at different forward speed during fertilization and weeding treatments and the following equations represent the relationship.

Two pass:  $y = 1.8833x + 1.0867 \quad R^2 = 0.99$

One pass:  $y = 1.3833x - 0.4133 \quad R^2 = 0.99$

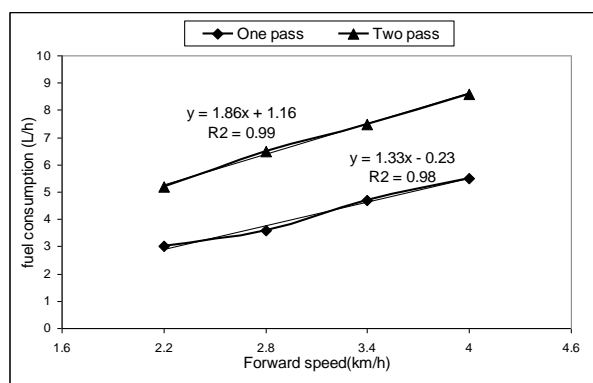

Fig 1: Relationship between forward speed and fuel consumption under the weeding and fertilizing treatments.

**2.The impact of forward speed on required power.**

Fig 2. shows the relationship between forward speed and Engine Power under the different weeding and fertilizing treatments. It was observed that using two pass method, the total engine power recorded 13.8 kW/h with 2.2 Km/h and increased to 18.1kW/h with 4 km/h. While by using one pass method the required power was 7.5 kW/h unit with the forward speed 2.2Km/h, and recorded the highest value 11.2 kW/h with 4 Km/h forward speed. It was obvious that one pass method saved engine power by 42.65%, 44.8%, 41.97% and

38.58% with forward speed 2.2 ,2.8, 3.4, and 4 km/h respectively. Linear regression analysis was performed to derive equations to predict engine power at different forward speed during fertilization and weeding treatments and the following equation represented the relationship.

Two pass:  $y = 2.43x + 8.40 \quad R^2 = 0.96$

one pass:  $y = 2.016x + 2.97 \quad R^2 = 0.96$

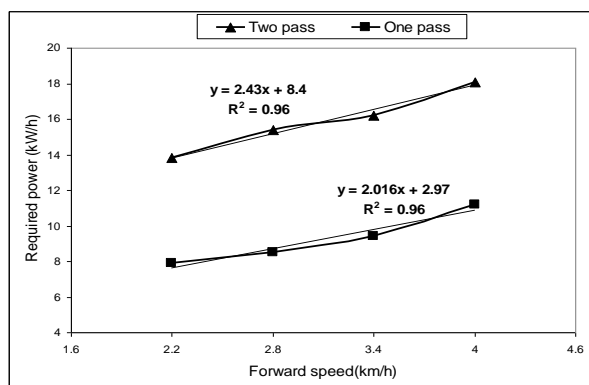

Fig.2.Relationship between forward speed and Engine Power under the different weeding and fertilizing treatments

### 3.The impact of forward speed on Energy requirements.

Fig.3. shows the relationship between forward speed and Energy required under the different weeding and fertilizing treatments. It was observed that using the traditional method, tow pass, increased the total energy requirements from 15.12 to 20 kW/h/fed by increasing forward speed from 2.2 up to 4 Km/h. Meanwhile by using one pass method energy requirements was increased from 9 to 12.8 kW/h/fed with as a result of increasing the forward speed from 2.2 up to 4 Km/h. It was observed that one pass method saved energy requirements by 40.8%, 42.7%, 41.3% and 36% with forward speed 2.2, 2.8, 3.4, and 4 km/h respectively. Linear regression analysis was run to derive equations to predict energy required at different forward speed during fertilization and weeding treatments and the following equation represented the relationship.

One pass:  $y = 0.0117x + 0.1028 \quad R^2 = 0.99$

Two pass:  $y = 0.0127x + 0.0467 \quad R^2 = 0.99$

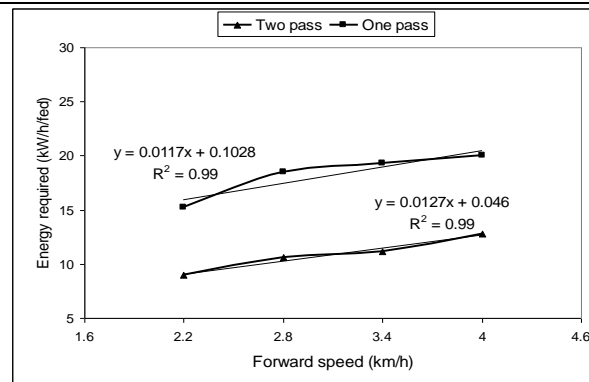

Fig.3.Relationship between forward speed and Energy required under the weeding and fertilizing treatments.

### 4.The impact of forward speed on theoretical field capacity.

Fig.4. shows the relationship between forward speed and theoretical field capacity under the different weeding and fertilizing treatments.it was clear that theoretical field capacity increased by forward speed increasing. using traditional method "two pass" theoretical field capacity was 1.4 fed/h with the forward speed 2.2km/h and reached to 2.7 fed/h with the forward speed 4 km/h . While using one pass method theoretical field capacity was 0.82 fed/h with the forward speed 2.2km/h and increased with the forward speed 4 km/h to reach to 1.6 fed/h. It was clear that one pass method saved theoretical field capacity with 41.4%, 42.1%, 37.5, and 37% with forward speed 2.2, 2.8, 3.4 and 4 Km/h, respectively.

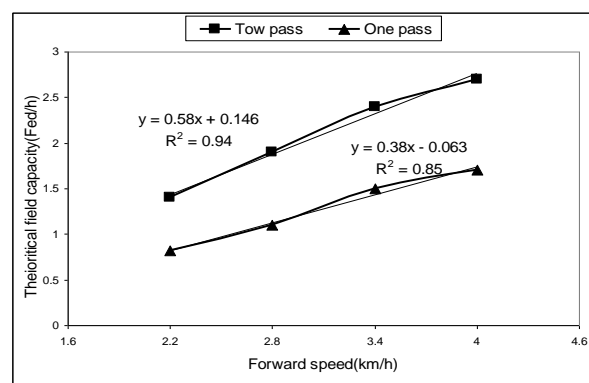

Fig.4.Relationship between forward speed and Theoretical field capacity under the weeding and fertilizing treatments.

Linear regression analysis was run to derive equations to predict theoretical field capacity at different forward speed during fertilization and weeding treatments and the following equation represented the relationship.

Two pass:  $y = 0.5867x + 0.146$   $R^2 = 0.94$

One pass:  $y = 0.3817x - 0.036$   $R^2 = 0.85$

### 5. The impact of forward speed on effective field capacity.

Fig.5. shows the relationship between forward speed and effective field capacity under the different weeding and fertilizing treatments obtained results show rise in the effective field capacity as the forward speed increased. using traditional method "tow pass" effective field capacity increased from 1.2 to 1.71 fed/h as the forward speed increased from 2.2 up to 4 km/h. while under using one pass method effective field capacity was 0.67 fed/h with the forward speed 2.2km/h and increased with the forward speed 2.8 Km/h to reach to 0.69 fed/h .and it was 0.84 fed/h with the forward speed 3.4 Km/h. The effective field capacity was recorded the highest value 0.98 fed/h with 4 Km/h forward speed. It was clear that one pass saved effective field capacity with 44.1%, 47.3%, 44.7, and 42.6% with forward speed 2.2, 2.8, 3.4 and 4 Km/h, respectively. Linear regression analysis was run to derive equations to predict effective field capacity at different forward speed during fertilization and weeding treatments and the following equation represented the relationship.

Two pass:-  $y = 30.33x + 76.96$   $R^2 = 0.99$

One pass:-  $y = 23.63x + 23.36$   $R^2 = 0.99$

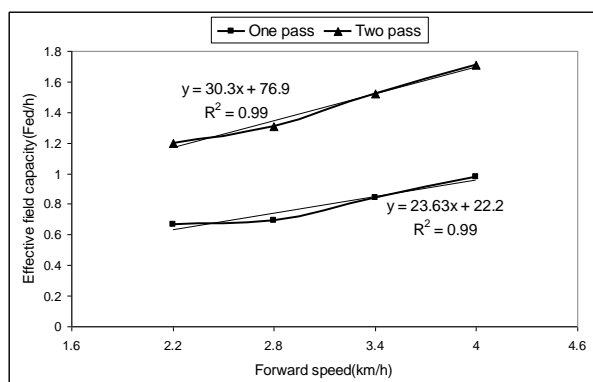

Fig.5. Relationship between forward speed and Effective field capacity under the weeding and fertilizing treatments.

### 6. The impact of forward speed on field efficiency.

Fig.6. shows the relationship between forward speed and field efficiency under the different weeding and fertilizing treatments. Obtained results show a remarkable drop in field

efficiency as the forward speed increased. using traditional method "tow pass" the field efficiency at weeding process was decreased from 79.5 to 54.4% as the forward speed increased from 2.2 up to 4 Km/h forward speed. using fertilizing process only the field efficiency was decreased from 84 to 56.4% as the forward speed increased from 2.2 up to 4 Km/h. Meanwhile using one pass method the field efficiency was 81.7% with the forward speed 2.2Km/h and decreased to 73% with the forward speed 2.8 Km/h .it was 62% at forward speed 3.4 Km/h .The value of field efficiency was reached to the minimum value 51 at 4 Km/h forward speed. Linear regression analysis was run to derive equations to predict field efficiency at different forward speed during fertilization and weeding treatments and the following equations represent the relationship.

Weeding:  $y = -13.68x + 110.29$   $R^2 = 0.98$

Fertilizing:  $y = -15.18x + 117.94$   $R^2 = 0.99$

One pass:  $y = -17.183x + 120.19$   $R^2 = 0.99$

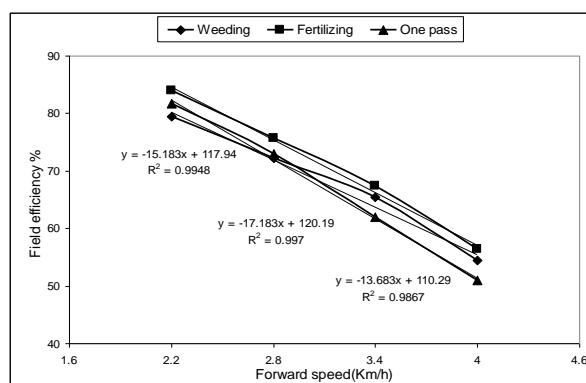

Fig.6. Relationship between forward speed and Field efficiency under the weeding and fertilizing treatments.

### 7. The impact of forward speed on fertilizer losses.

Fig. 7 shows the relationship between forward speed Km/h and fertilizer losses. It was clear that the fertilizer losses increased as the forward speed increased. applying the nitrogen rate of 30Kg.N.fed-1 losses increased from 2.4 to 2.98 kg/fed as the forward speed increasing from 2.2 up to 4 Km/h. while applying the rate of 45Kg.N.fed-1 losses was increased from 3.54 to 4.94 kg/fed as the forward speed increased from 2.2 up to 4 Km/h forward speed. While applying the rate

of 60Kg.N.fed-1 losses increased from 4.8 to 5.8 kg/fed by increasing the forward speed from 2.2 up to 4 Km/h. Linear regression analysis was run to derive equations to predict fertilizer losses different forward speed during fertilization and weeding treatments and the following equation represented the relationship.

60 kg.N.fed<sup>-1</sup> :  $y = 0.54x + 3.57$   $R^2 = 0.97$   
 45 kg.N.fed<sup>-1</sup> :  $y = 0.77x + 1.73$   $R^2 = 0.96$   
 30 kg.N.fed<sup>-1</sup> :  $y = 0.31x + 1.694$   $R^2 = 0.95$

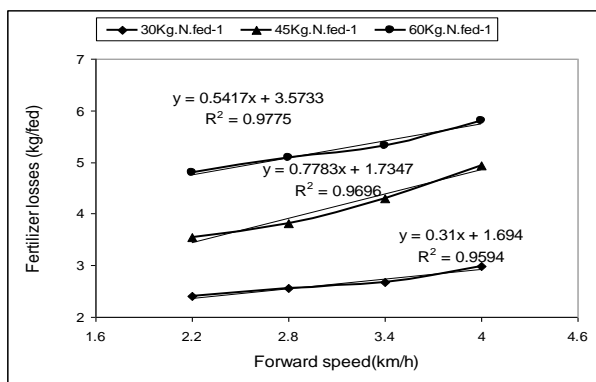

Fig.7. Relationship between forward speed and Fertilizer losses ratio under the fertilizing treatments.

**8.The impact of forward speed on weed index.**

Fig.8 shows the relationship between forward speed Km/h and weed index under different weeding treatments. It was obvious that by increasing forward speed from 2.2 Km/h up to 2.8 Km/h the weeding index was decreased from 86.12% to 83.8%. by increasing forward speed from 3.4 Km/h to 4 Km/h the weeding index decreased from 80.9 % to 78.3% under the control (manual) treatment . Meanwhile using traditional method weeding index was decreased from 91.28% to 90.18% and from 88.78% to 87.74% by increasing the forward speed from 2.2 Km/h to 2.8 Km/h , and from 3.4 Km/h to 4 Km/h. on the other hand when using one pass method machine the weeding index was decreased from 90 to 88.64 by increasing forward speed from 2.2 Km/h to 2.8 Km/h and decreased from 86.7 6 to 84.87 with forward speed 3.4 Km/h, 4 Km/h respectively. Linear regression analysis was run to derive equations to predict weeding index at different forward speed during fertilization and weeding treatments and the following equation represented the relationship.

relationship.

One pass:  $y = -2.003x + 95.70$   $R^2 = 0.99$   
 traditional:  $y = -2.878x + 96.49$   $R^2 = 0.99$   
 control :  $y = -4.3933x + 95.89$   $R^2 = 0.99$

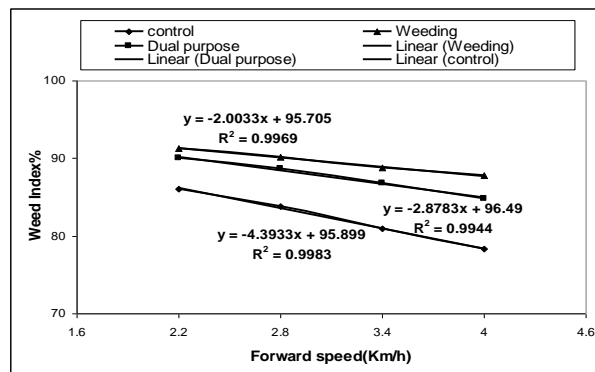

Fig.8. Relationship between forward speed and Weed index.

**9.Effect of machine forward speed on hourly cost.**

Fig. 9 shows the effect of machine forward speed on hourly costs, it was clear that Data obtained showed that increasing the forward speed from 2.2 to 4 km/h increased the hourly cost from 155 to 159.8. L.E/Fed by applying the traditional method for weeding and fertilizing. While by using one pass method for weeding and fertilizing together there was a remarkable drop in hourly costs it was increased from 77.5 to 80 L.E/Fed as the forward speed increased from 2.2 up to 4 km/h respectively.

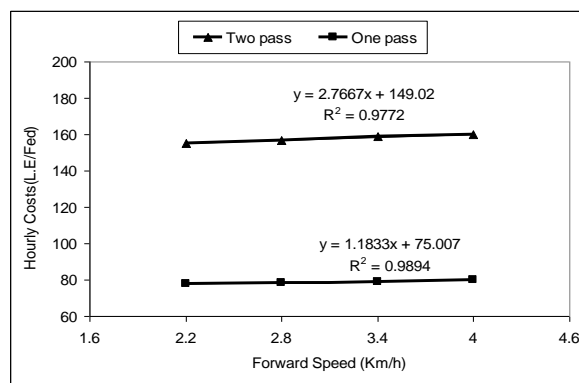

Fig.9.Effect of machine forward speed on hourly cost under fertilizing and weeding treatments.

Linear regression analysis was run to derive equations to predict hourly costs at different forward speed during fertilization and weeding treatments and the following equation represented the relationship

Two pass:  $y = 2.15x + 161.76$   $R^2 = 0.74$

One pass:  $y = 1.466x + 74.85$   $R^2 = 0.27$

### 10. Effect of machine forward speed on operational cost.

Fig. 10 shows the effect of machine forward speed on operational costs, it was clear that, using the traditional method two pass for weeding and fertilizing the operational costs was decreased from 140 to 96.3 L.E/Fed as the forward speed increased from 2.2 to 4 Km/h.

While by using one pass method for weeding and fertilizing together the operational cost was decreased from 108 to 80.3 L.E/Fed as the forward speed increased from 2.2 to 4 Km/h. The decrease in operational costs by increasing forward speed is attributed to the increase of machine field capacity.

Linear regression analysis was run to derive equations to predict operational costs at different forward speed during fertilization and weeding treatments and the following equation represented the relationship

Two pass:  $y = -20.93x + 185.05$   $R^2 = 0.98$

One pass:  $y = -12.66x + 132.7$   $R^2 = 0.99$

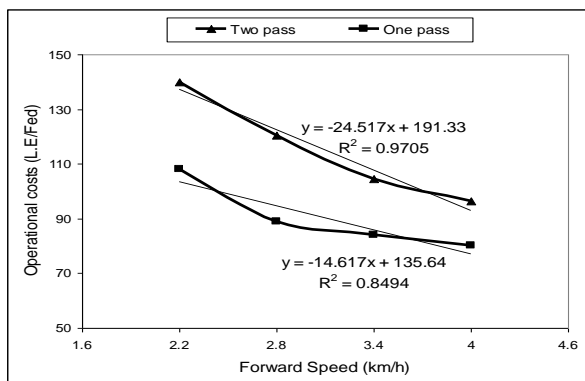

Fig. 10. Effect of machine forward speed on operational cost under different fertilizing and weeding treatments.

## CONCLUSIONS

It was concluded that the fuel consumption, energy requirements, and operational costs were the optimum region during the weeding and fertilization at the forward speed of about 2.8 km/h.

## REFERENCES

[1]Awady, M. N., Ghoneim, E. Y., Hashish, A. I., 1982, A critical comparison between wheat

combine harvesters under Egyptian conditions. R. S. No. 1920, Ain-Shams Univ. Food and Agriculture Organization (FAO).

[2]Ebaid, M.T., 2005, Properties of some medical grains affecting sieve unit selection. *Mistr.J., Ag.,Eng.*, 22(3):861-873.

[3]Embaby, A. T., 1985, A comparison of different mechanization systems of cereal crop production. M.Sc. Thesis. Fac. of Agric., Cairo University, Egypt.

[4]Krishnan, A., Duraiswamy, V. M., Karunanithi, R., Kavitha, R., 2004, Frontline demonstration on power weeder (sugarcane crop). All India Co-ordinated Research Project progress report, TNAU Coimbatore.

[5]Mullen, R.W., Freeman, K.W., Raun, W.R., Johnson, G.V., Stone, M.L., Solie, J.B., 2003, Identifying an in season response index and the potential to increase wheat yield with nitrogen. *Agronomy Journal* 95, 347-351.

[6]Pannu, C. J. S., Dixit, A., Garg, I. K., Dogra, B., 2002, Feasibility evaluation of rotary power weeder on wider row crops like cotton, maize, sunflower, soybean etc. Annual Report, Punjab Agricultural University, Ludhiana: 18-26. PAU, India.

[7]Yuan, Cheng-Liang Liu, Yan-Ming Li, Qingbing Zeng, Xuan F. Zha, 2010, Gaussian processes based bivariate control parameters optimization of variable-rate granular fertilizer applicator *Computers and Electronics in Agriculture* 70 .33-41.

## THE SMALL AND MEDIUM ENTERPRISES AS THE BASIC COMPONENT OF THE ENTREPRENEURIAL ACTIVITY IN THE REPUBLIC OF MOLDOVA

**Liliana GRINCIUC**

The State Agricultural University of Moldova, 44 Mircesti, Chisinau, Republic of Moldova,  
Phone: + 373 22 432 432, Email: lgrinciuc@gmail.com

*Corresponding author:* lgrinciuc@gmail.com

### **Abstract**

*The aim of the research was to study and put into evidence the importance of the small and medium enterprises as the basic component of the entrepreneurial activity in the Republic of Moldova. As a result of the investigated research topic, it can be noted that during the last 5 years, the number of small and medium enterprises was growing steadily, increasing from 43.7 thousand enterprises in 2009 to 50.9 thousand enterprises in 2013, the sector had a share about 97.4 percent of the total number of registered enterprises in the year 2013. The growing results were recorded in the last two years on revenue of the sales and obtained profit, and according to the types of activities the most of the requested enterprises are those in the wholesale and retail, sector rentals, real estate transactions and activities to provide services for enterprises.*

**Key words:** competition, income, innovation, market economy, micro enterprises, products, services, small and medium enterprises

### **INTRODUCTION**

Contemporary economy is presented by a wide variety of enterprises and their structures; their dimensions, roles and features are greatly diversified. Currently small and medium-sized enterprises (hereafter SMEs) are the most common form of business organization, which fulfils various economic, technical and social functions. There is no country with a market economy without any SMEs. SMEs are an important development factor of each nation's economy; they are also called "the backbone of the economy"[4]. The role and importance of SMEs in the national economy development is characterized by some features, and namely:

- direct contribution to the gross domestic product in every country, usually between 55-95%;
- creation of new jobs;
- competition enhancement;
- export growth;
- innovation and technology promotion[6].

If compared with large enterprises, SMEs are more flexible and react more rapidly to the changes of the business environment and

market requirements, they provide the staff with the opportunity to enhance their qualifications and to apply for the positions in large enterprises, they also enhance competition and improve the functioning of large enterprises, providing various services or producing various subsets; they manufacture products and provide services in terms of efficiency [1].

Thus, the described sector of the national economy offers relevant possibilities to implement creative entrepreneur skills and leadership abilities; investments in this sector result in higher incomes.

### **MATERIALS AND METHODS**

The research has been conducted based on the information and studies on SMEs as key components of the entrepreneurial activity in the Republic of Moldova. In order to study the issue we have used professional literature, the data of the National Bureau of Statistics of the Republic of Moldova and the Ministry of Agriculture and Food Industry. The analytical count method as well as the table method and the graphical method have been used to interpret the gathered information and

calculations. The analysis method was applied to interpret the results. The authors have used the method of induction and deduction to draw conclusions.

## RESULTS AND DISCUSSIONS

The interest in one's own business is being increased along with the transition to new market relations. The humanity is going through a new economy type, the knowledge-based economy where a knowledge-based company is its main component. The studies so far show that the prototype of a knowledge-based company is a small or medium-sized enterprise. These organizations have become increasingly important in the contemporary society, because the development of this sector increases the prosperity and improves living standards of the population; it also represents a number of important factors for the social stability, such as:

- Both production and economy increase;
- Contribution to the creation of new jobs;
- Diversification of products and services in the market;
- Product quality improvement and consumer demand satisfaction;
- Different people's self-realization, ensuring their economic freedom;
- Welfare increase;
- Profitable investment direction, initiated from one's own sources;
- Rapid adjustment of the range of products and services to the market demand;
- Development of the entrepreneurial spirit;
- Formation of middle class homeowners that would ensure stability in the society, etc.

Thus, firstly, SMEs contribute to the improvement of the economic situation and stimulate its growth. This increase results in the income for the state budget by means of the tax system, the income can then be distributed to the other members of the society. SMEs also contribute greatly to the diversity of products and services, increasing their quality and, as a result, the consumer demand is satisfied. Having reduced material and financial resources, SMEs are not able to produce large quantities of homogeneous

goods, therefore, in order to succeed they use gaps in the market or create new markets themselves, providing a wide range of products that would meet the tastes and requirements of different groups of consumers.

In the Republic of Moldova, the SME sector emerged as a result of the transition from the centralized economy to the market economy in the late 1990s. At that time there was an explosion in the development and establishment of SMEs, which resulted in their strong position in the national economy [2]. Taking into consideration the importance of the small and medium-sized enterprises sector in ensuring the sustainable country development, the Moldovan Parliament adopted the Law nr. 206 of July 7, 2006 on supporting the small and medium-sized enterprises sector, which provides three types of companies:

- micro enterprises – the annual average number of employees is not more than 9 people, the total annual sales revenues is not more than 3 million lei and the total annual value of the assets does not exceed 3 million lei;
- small enterprises – the annual average number of employees is not more than 49 people, the total annual sales revenues is not more than 25 million lei and the total annual value of the assets does not exceed 25 million lei;
- medium-sized enterprises – the annual average number of employees is not more than 249 people, the total annual sales revenues is not more than 50 million lei and the total annual value of the assets does not exceed 50 million lei [5].

During the last 5 years the number of SMEs was increasingly growing, from 43,700 companies in 2009 to 50,900 enterprises in 2013.

The SMEs sector represents about 97.4% of the total number of registered enterprises in 2013 [3].

The evolution of SMEs in the period 2009 - 2013 is presented in Table 1.



Table 1. The evolution of SMEs in Moldova during the years 2009 - 2013

Years	The number of enterprises, thousand		
	The total	SMEs	The share of SMEs in the total, %
2009	44.6	43.7	97.8
2010	46.7	45.6	97.7
2011	48.5	47.3	97.5
2012	50.7	49.4	97.5
2013	52.2	50.9	97.4

Source: the National Bureau of Statistics of the Republic of Moldova, Entrepreneurship

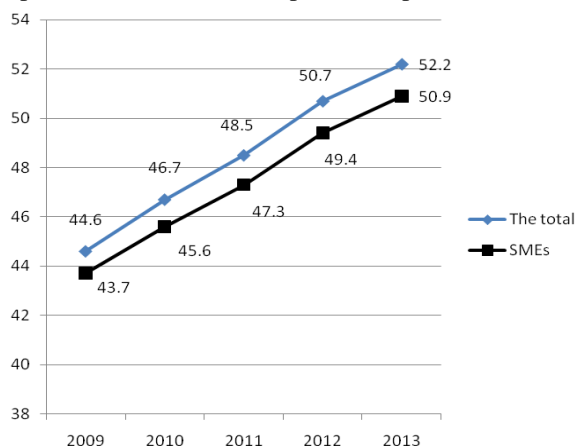

Fig.1. The dynamic evolution of SMEs in Moldova in 2009-2013, thousand units.

Source: developed by the author.

The current status of SMEs can be characterized by such indicators as: the number of employees or workers, the amount of revenues from sales and financial results characterized by the amount of registered profits or losses. In the last 5 years there has been a decrease in the number of people working in SMEs [3].

In 2009 the number of employees amounted to 316,200 people, or 58.7% of the total number of employees, in 2013 their number decreased by 17.8 thousand and was 298,400 people, which is 1.8% less than in 2009.

As for the amount of income from sales, it is evident that it was increasing in that period.

In 2009 the revenues from sales amounted to Lei 57,480 mil., in 2013 the number increased by Lei 19,933.2 mil. lei and was Lei 77,413.2 mil. (Table 2).

Based on the data presented in Tables 3 and 4, we are going to analyze the dynamic evolution of the number of SMEs and revenues from sales according to the main types of activities [3].

Table 2. The evolution of the number of employees and revenues from sales at SMEs in 2009-2013

Years	The number of employees, thousand people			Revenues from sales, mln. lei		
	The total	SMEs	The share of SMEs in the total, %	The total	SMEs	The share of SMEs in the total, %
2010	526.2	309.4	58.8	177,503.2	65,263.2	36.8
2011	510.2	294.2	57.7	207,676.8	71,887.6	34.6
2012	519.9	300.2	57.7	211,759.3	73,057.0	34.5
2013	524.5	298.4	56.9	231,601.4	77,413.2	33.4

Source: The National Bureau of Statistics of the Republic of Moldova, Entrepreneurship

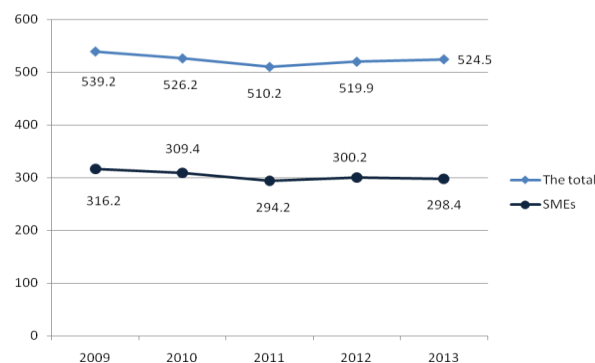

Fig.2. The dynamic evolution of the number of employees at small and medium-sized enterprises, thousand people.

Source: developed by the author.

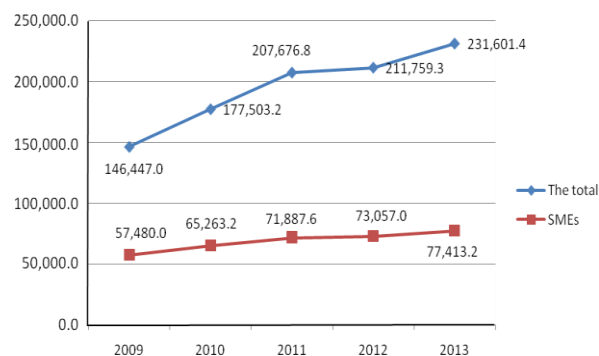

Fig.3. The dynamic evolution of revenues from sales of small and medium-sized enterprises, mln. lei.

Source: developed by the author

Taking into account the data provided in Table 3, it is obvious that the largest number of SMEs may be found in the wholesale and retail sector, which is 20,400 units of the total of 50,900 units registered in 2013 or by 400 units more than in 2012.

Table 3. The dynamic evolution of the number of SMEs according to the main types of activities in 2012-2013

Types of activities	2012			2013			2013 in % as compared to 2012
	SMEs (thousand units)	The share of SMEs in:		SMEs (thousand units)	The share of SMEs in:		
		The total of enterprises, %	The total of SMEs, %		The total of enterprises, %	The total of SMEs, %	
The total, including the main types of activities of enterprises:	49.4	97.5	100	50.9	97.4	100	102.9
Agriculture, hunting and forestry	2.5	97.6	5.0	2.7	97.6	5.2	107.0
Manufacturing	4.9	95.8	9.8	4.9	95.3	9.6	100.1
Electricity, gas and water	0.2	86.8	0.5	0.3	88.1	0.6	118.9
Construction	2.7	96.9	5.5	2.7	96.7	5.3	99.1
Wholesaling and retailing	20.0	97.8	40.5	20.4	97.6	40.0	101.6
Hotels and restaurants	1.7	99.4	3.4	1.7	99.4	3.3	102.6
Transport and communication	3.3	98.1	6.7	3.4	97.9	6.7	102.5
Real estate, renting and services for enterprises	8.5	98.4	17.2	9.0	98.3	17.6	105.8
Other activities	5.7	97.1	11.5	6.0	96.5	11.7	105.3

Source: the National Bureau of Statistics of the Republic of Moldova, Entrepreneurship

Other 9.0 thousand units of SMEs in 2013 are registered in the sphere of real estate transactions, rent and services provided for the enterprises, it is by over 500 units more than in 2012.

Then the manufacturing sector comes which remains at the same level in the last two years and equals to 4,900 units. If we analyze SMEs in agriculture, hunting and forestry, we can mention that in 2013 their number increased by 200 units as compared to 2012.

The number of SMEs in the transport, communication, electricity and gas sector increased by 100 units in 2013 as compared to 2012.

These data prove once again that the interest in one's own business is constantly growing. Analyzing the amount of revenues from sales according to the main types of activities from both Table 4 and Fig.4., we can conclude that the highest revenues are registered at the SMEs that operate in the wholesale and retail sector, accounting to Lei 36,333 mil. in 2013 or by Lei 34 mil. more than in 2012.

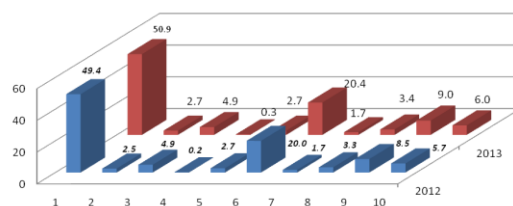

Fig.4. The dynamic evolution of the number of SMEs according to the main types of activities.

Source: developed by the author

Legend: 1.SMEs, 2.agriculture, hunting and forestry; 3.manufacturing; 4.electricity, gas and water; 5.construction; 6.wholesaling and retailing; 7.hotels and restaurants; 8.transport and communication; 9.real estate, renting and services for enterprises; 10.other activities

Table 4. Revenues from sales of SMEs according to the main types of activities

Activity	2012				2013			
	The total, mln lei	SMEs mln lei	The share of SMEs in:		The total, mln lei	SMEs mln lei	The share of SMEs in:	
			The total of enterprises%	The total of SMEs %			The total of enterprises%	The total of SMEs %
The total, including the main types of activities of enterprises:	211,759.3	73,057.0	34.5	100.0	231,601.4	77,413.2	33.4	100.0
Agriculture, hunting and forestry	7,257.6	4,930.3	67.9	6.7	8,931.6	6,157.8	68.9	8.0
Manufacturing	33,265.7	9,522.8	28.6	13.0	37,144.2	9,640.9	26.0	12.5
Electricity, gas and water	22,355.2	261.8	1.2	0.4	19,402.9	236.3	1.2	0.3
Construction	8,439.8	5,349.9	63.4	7.3	10,572.3	6,109.9	57.8	7.9
Wholesaling and retailing	98,590.9	36,299.0	36.8	49.7	107,906.2	36,333.0	33.7	46.9
Hotels and restaurants	1,830.5	1,365.8	74.6	1.9	1,998.9	1,482.0	74.1	1.9
Transport and communication	19,423.7	6,885.1	35.4	9.4	21,273.0	7,700.6	36.2	9.9
Real estate, renting and services for enterprises	8,021.7	5,177.2	64.5	7.1	2,909.3	5,942.4	204.3	7.7
Other activities	12,574.2	3,265.0	26.0	4.5	21,463.1	3,810.3	17.8	4.9

Source: The National Bureau of Statistics of the Republic of Moldova, Entrepreneurship

Then, on the 2n position came the manufacturing sector which had revenues of Lei 9,640.9 mil. in 2013, it is by Lei 118.1 mil. more than in 2012.

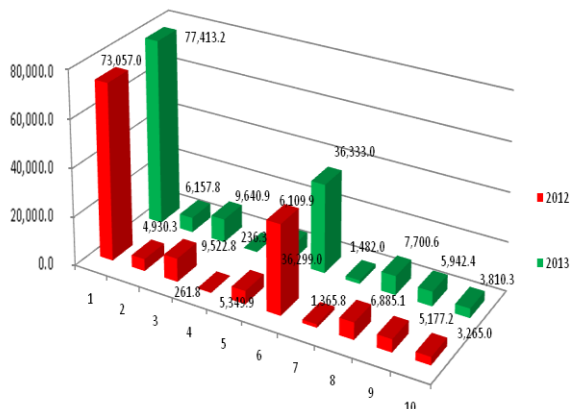

Fig.5. Revenues from sales of SMEs according to the main types of activities.

Legend: 1.SMEs, 2.agriculture, hunting and forestry; 3.manufacturing; 4.electricity, gas and water; 5.construction; 6.wholesaling and retailing; 7.hotels and restaurants; 8.transport and communication; 9.real estate, renting and services for enterprises; 10.other activities

Table 5. The financial results achieved by SMEs in the period 2012-2013

Types of activities	Profits (+), losses (-) before taxation, mln lei							
	2012				2013			
	SMEs - the total	including			SMEs - the total	Including		
		medium-sized	small	micro		medium-sized	small	Micro
The total	1,084.6	393.6	715.9	-24.8	2,008.5	657.1	1,267.3	84.2
including the main types of activities of enterprises:								
Agriculture, hunting and forestry	-53.5	29.1	-41.6	-40.9	389.7	195.9	187.0	6.8
Manufacturing	9.8	32.0	2.9	-19.3	316.6	216.1	107.1	-6.5
Electricity, gas and water	-42.4	-22.9	-17.1	-2.3	3.9	28.8	-11.8	-13.1
Construction	97.0	-4.2	84.9	16.3	350.7	155.2	174.7	20.8
Wholesaling and retailing	695.4	271.6	540.5	-116.6	620.3	210.1	551.4	-141.2
Hotels and restaurants	-119.9	-14.4	-57.7	-47.7	-115.2	-12.8	-60.2	-42.3
Transport and communication	-37.1	-6.8	-48.6	18.3	118.5	82.3	37.1	0.8
Real estate, renting and services for enterprises	469.1	72.1	251.2	145.8	252.7	-216.6	257.2	212.1
Other activities	66.2	37.2	7.3	21.7	71.3	-2.0	24.8	48.4

Source: the National Bureau of Statistics of the Republic of Moldova, Entrepreneurship

The rest of the SME sectors have registered an increase of revenues from sales in 2013 as compared to 2012, except the sector of electricity, gas and water: the revenues from sales decreased by Lei 25.5 mil. in 2013 as compared to 2012.

The situation with SMEs in the country can be characterized by analyzing their financial situation determined by the amount of profits or losses recorded in the last two years.

The amount of profits / losses before taxation gained by small and medium-sized enterprises was Lei 2,008.5 mil. in 2013, or by Lei 923.9 mil. more than in 2012.

The losses were registered only at the enterprises from the sector of hotels and restaurants.

Having analyzed the SMEs sector in the Republic of Moldova, we notice that the most demanded fields of business are wholesaling and retailing, real estate transactions, renting and services for enterprises. According to the content, this shows that the mentioned sectors imply no maximum risks and the high speed of assets rotation provides a short-term payback, which presents a great advantage for them.

## CONCLUSIONS

SMEs are an important development factor of each nation's economy; they are also called "the backbone of the economy". The development of this sector provides prosperity and improves living standards of the population; it also represents an important factor of the social stability. SMEs are the main force for the socio-economic development, ensuring the sustainable economic growth of the country, as well as the largest business sector in any country with a market economy. SMEs generate most of the GDP of each country; provide most jobs; are the main promoters of the knowledge-based economy. As SMEs are more flexible and react more quickly to the changes of the business environment as well as market demands, it is demonstrated by their practice that investments in SMEs lead to higher incomes than investments in large enterprises. Thus, we can conclude that the small and medium-sized enterprises need to be supported by the state by creating stable legal and economic conditions, favourable to the development of the entrepreneurial activity in Moldova.

## REFERENCES

- [1] Certan, S., 2012, Teoria administrării afacerilor. Chişinău: CEP USM, 400 p.
- [2] Chişlari, E., 2005, Antreprenoriatul: diversitatea

modelelor și mecanismelor de realizare. Chișinău: Editura ASEM, 217 p.

[3]Date statistice privind activitatea întreprinderilor mici și mijlocii în R. Moldova//www.statistica.md.

[4]Drucker, P., 1993, Inovația și sistemul antreprenorial, Editura Enciclopedică, București, pp.25.

[5]Legea privind susținerea sectorului întreprinderilor mici și mijlocii nr.206-XVI din 07.07.2006.

[6]Nicolescu, O. 2011, Managementul întreprinderilor mici și mijlocii: concept, metode, aplicații, studii de caz. București: Editura Economică, 448 p.

## EFFECT OF VARIOUS INPUTS ON PADDY PRODUCTION - A COMPARISON OF ARTIFICIAL NEURAL NETWORKS AND LINEAR REGRESSION ANALYSIS

Mohammad Ali HORMOZI<sup>1</sup>, Abbas ABDESHAHI<sup>2</sup>, Mohammad Amin ASOODAR<sup>1</sup>

<sup>1</sup>Ramin Agriculture and Natural Resources University of Khuzestan, Department of Agricultural Machinery and Mechanization, Mollasani, Iran, Phone/fax: +98.61.3652.3922, Emails: hormozi@ramin.ac.ir, asoodar@scu.ac.ir

<sup>2</sup>Ramin Agriculture and Natural Resources University of Khuzestan, Department of Agricultural Economics, Mollasani, Iran, Phone/fax: +98.61.3652.2434, Email: ahmadreza1378@yahoo.com

*Corresponding author.* hormozi@ramin.ac.ir

### Abstract

*We analyzed the effect of chemical fertilizer, seed, biocide, farm machinery and labor hours on production of paddy (paddy rice) in the Khuzestan province in the South Western part of Iran. Here we test two methods (linear regression and neural network). We conclude that the results gotten by neural network with no hidden layer and linear regression are closed to each other. We insist that for a data set of this type the regression analysis yields more reliable results compared to a neural network. They suggest that machinery has a very clear positive effect on yield while fertilizer and labor doesn't affect on it. One can say that there is no necessity that increasing the amount of some "useful input" increase paddy production.*

*Key words:* neural networks, linear regression, paddy

### INTRODUCTION

Rice is one of the most important cereal crops grown globally. Rice is important as a staple human food source in many areas of Iran, where the per capita consumption of rice is approximately 100 grams per day. In 2008, which was a drought year, statistics show that Iran had 527,000 hectares of paddy cultivation. The Khuzestan province is normally known as the fifth largest rice producer, with 15,000 hectares devoted to rice production; nonetheless, due to low productivity, the paddy production of Khuzestan was announced to be sixth highest in Iran in 2008 [5]. In a normal year, rice-cultivated areas may reach 59,000 hectares [4]; however, the nearly 1400-kg/ha difference among the regions of Khuzestan shows there are other variables that affect productivity [1]. Moreover, some reasons make it difficult to predict the effect of variables on productivity. For example, the situation of climate; the climate of Khuzestan is generally hot and occasionally humid, particularly in the south, while winters are

much more pleasant and dry. Summertime temperatures routinely exceed 50 degrees Celsius and in the winter it can drop below freezing, with occasional snowfall, all the way south to Ahvaz. Khuzestan province is known to master the hottest temperatures on record for a populated city anywhere in the world. Many sandstorms and dust storms are frequent with the arid and desert-style terrains.

In this project, we will give the effect of chemical fertilizer, seed, biocide, farm machinery and labor hours on production of paddy (paddy rice) in the Khuzestan province by using two methods (linear regression and neural network).

### MATERIALS AND METHODS

The research survey was undertaken in the Khuzestan province in South Western Iran. The data used in this study were collected during a survey covering the crop year of 2009 in two climatic regions: (I) mountainous North Eastern Khuzestan and (II) the plains (the rest of Khuzestan). The Baghmalek and

Izeh districts from region (I) and the Ahvaz, Shushtar, Dezful, Shush, Ramhormoz and Dashte-Azadegan districts from region (II) were chosen. The data set consists of 93 observations. It includes amongst six variables: The output of production as dependent variable is kilogram per hectare (kg/ha) of paddy, the inputs as quantitative variables are namely chemical fertilizer (kg/ha) that was applied in the farm, seed planted per hectare (kg/ha), biocides including insecticide, herbicide, and fungicide that were used by farmers (kg/ha), farm machinery that energy equivalent is used in this study (mega joule per hectare) and labor hours that were applied (h/ha) [3].

The main goal of this project is to detect the effect of chemical fertilizer, seed, biocides, farm machinery and labor hours on paddy production. To achieve this we use two methods.

The "Neural Network" as employed here is obviously not a biological concept. It is artificial. In the regime of neural networks, "Neural Networks" and "Artificial Neural Networks" are interchangeable. Neural networks are inspired by the functioning of the biological network of neurons in human brain. A neural network resembles the brain in two respects: First, knowledge is acquired by the network from its environment through a learning process; second, interneuron connection strengths, known as synaptic weights, are used to store the acquired knowledge. It is certain that a neural network model is composed of many neurons, which are basic units that work like computer processors. The units are connected by communication paths (connections) with weights. The units operate only on the inputs that they receive via the connections, and then send the outputs to the next layer of units. As a neural network model, it should have some sort of "training" rule whereby the weights of connections are adjusted on the basis of training set data. Neural networks use a series of neurons in what is known as the hidden layer that apply nonlinear activation functions to approximate complex functions in the data [2]. In this study we consider a Neural Network with no hidden layer.

Linear regression is an approach to modelling the relationship between a scalar dependent variable  $y$  and one or more explanatory variables denoted  $X$ . The case of one explanatory variable is called simple regression. More than one explanatory variable is multiple regression. (This in turn should be distinguished from multivariate linear regression, where multiple correlated dependent variables are predicted, (citation needed) rather than a single scalar variable.)

Linear regression models are often fitted using the least squares approach, but they may also be fitted in other ways, such as by minimizing the "lack of fit" in some other norm (as with least absolute deviations regression), or by minimizing a penalized version of the least squares loss function as in ridge regression [2].

## RESULTS AND DISCUSSIONS

**Neural Network.** A summary of the main results is provided by Table 1-2 and Fig. 1-2. Where "t.y." stands for "to yield". The process needed 7098 steps until all absolute partial derivatives of the error function were smaller than 0.01 (the default threshold). The estimated weights range from -18.25 to 550.48. The output of the neural network, i.e. the fitted values  $\hat{y}(x)$ , is provided by Table 2.

Table 1. Coefficients for neural network

Intercept.t.y.	Fertilizer.t.y.	Biocide.t.y.	Seed.t.y.	Machinery.t.y.	Labor.t.y.
550.48	1.26	-18.25	-4.51	3.21	0.54

Table 2. Output of the neural network

Fertilizer	Biocide	Seed	Machinery	Labor	Output
258	2	150	1067.45	306.5	3759.03
184	6.5	100	1046.05	284.1	3728.47
46	6	150	770.63	533	2588.21
115	1	100	697.63	490	2734.24
115	0	200	1050.95	320	3343.85
161	3.5	150	822.23	531	2943.52

Figure 1 suggests that machinery has positive effect to the yield status. The generalized weights are given for all covariates within the same range (Fig. 2).

The distribution of the generalized weights suggests that the covariate fertilizer and labor have no effect on the yield status since all generalized weights are nearly zero.

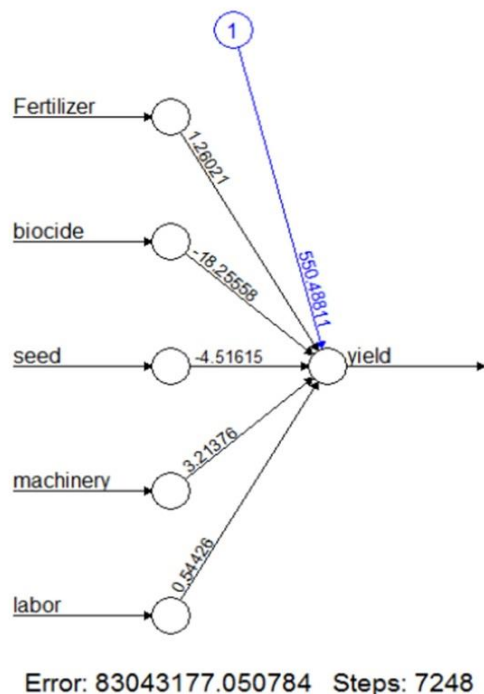

Fig. 1. Summary of the main results for neutral networks

**Linear Regression.** A summary of the main results is provided by Table 3-4 and Fig. 3. In the output from this first analysis, the p-value for the full model is 0.002540815, small enough to suggest that at least one of the predictor variables is significant in the model. The adjusted R square is 0.14 which indicates that the predictor variables explain 14 percent of the variance in the response variable. We believe that "Machinery" is the predictor variable which is useful for prediction, this result is same as what we get from neural network but **for a data set of this type the regression analysis yields more reliable results compared to a neural network.** Coefficients for linear regression are given in Table 4.

It suggests that machinery has positive effect to the yield while fertilizer and labor doesn't affect on it. This result is quite similar (with a little difference) to what we get from neural network (see Fig. 1).

The plot in the upper of Fig. 3 shows the residual errors plotted versus their fitted values.

The second plot (from up to down) is a standard Q-Q plot, which should suggest that the residual errors are normally distributed. The scale-location plot (third one) shows the square root of the standardized residuals (sort of a square root of relative error) as a function of the fitted values.

Finally, the plot in the lower shows each points leverage, which is a measure of its importance in determining the regression result.

For many observations, Cook's distance is less than 1 hence most of them may not be considered an outlier.

Table 3. Output of the linear regression

Input	Estimate	Std. Error	t value	Pr(> t )
Intercept	550.48	1077.09	0.51	0.61
Fertilizer	1.26	2.09	0.60	0.54
Biocide	-18.25	81.72	-0.22	0.82
Seed	-4.51	3.82	-1.17	0.24
Machinery	3.21	0.86	3.69	0.0004***
Labor	0.54	0.56	0.95	0.34

Table 4. Coefficients for linear regression

Intercept	Fertilizer	Biocide	Seed	Machinery	Labor
550.48	1.26	-18.25	-4.51	3.21	0.54

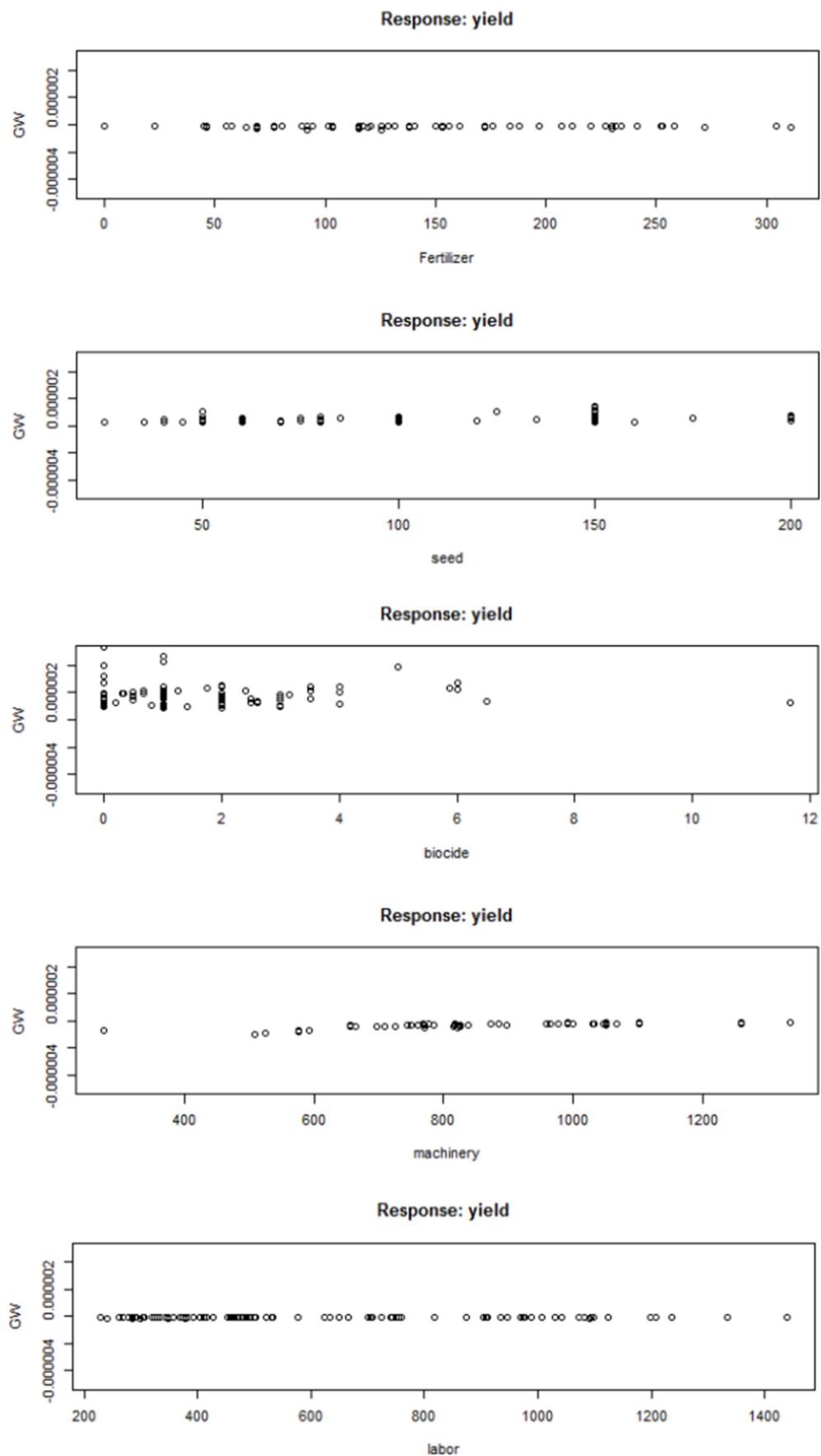

Fig. 2. Plots of generalized weights with respect to each covariate.



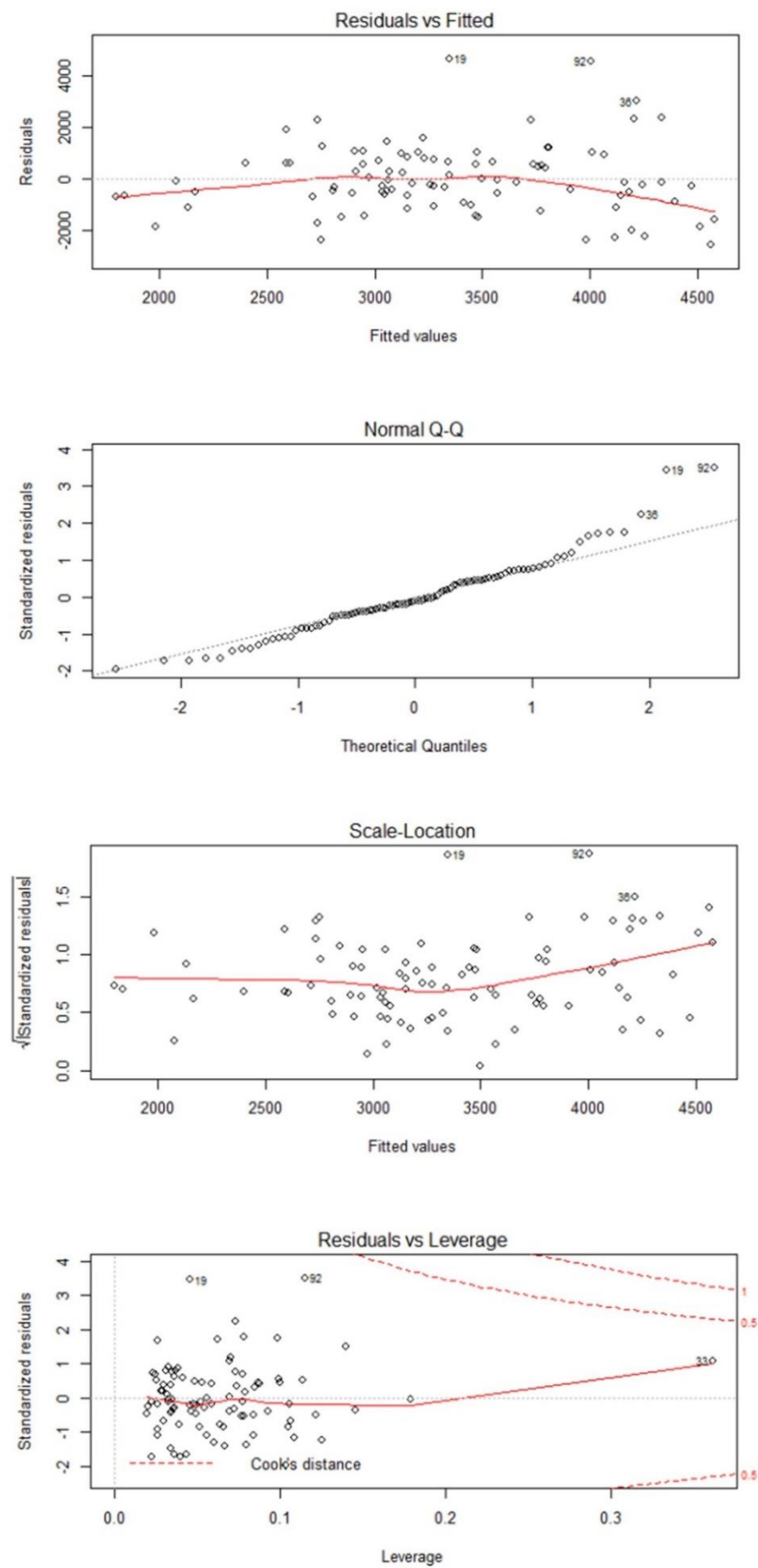

Fig. 3. Plots of linear regression

## CONCLUSIONS

We conclude that the results gotten by neural network with no hidden layer and linear regression are closed to each other. We insist that for a data set of this type the regression analysis yields more reliable results compared to a neural network. They suggest that machinery has a very clear positive effect on yield while fertilizer and labor does not affect on it. One can say that there is no necessity that increasing the amount of some "useful object" increase plant growth. Hence result makes sense.

As a future work someone can use qualitative variable e.g "transplanting in mountainous region", "transplanting in plain region", "wet seeding in poor drainage lands", "wet seeding in normal drainage lands" and "Dry seeding" or using other methods.

## REFERENCES

- [1]AOKP, 2007, Status report of rice production in Khuzestan province. Agriculture Organization of Khuzestan Province. Ahvaz. 55 pp.
- [2]Bishop, C.M., 2006, Pattern Recognition and Machine Learning, New York: Springer. 738 pp.
- [3]Hormozi, M.A., Asoodar, M.A., Abdeslahi, A., 2012, Impact of mechanization on technical efficiency: A case study of rice farmers in Iran, *Procedia Economics and Finance*. 1:176–185.
- [4]MJA, 2006, Agricultural statistics. Department of Statistics and Info-Technology. Ministry of Jihad-Agriculture. Tehran, Iran. Vol I.
- [5] MJA, 2008, Agricultural statistics. Department of Statistics and Info-Technology. Ministry of Jihad-Agriculture. Tehran, Iran. Vol I.

## EDUCATION IMPACT ON THE RESULTS OBTAINED IN AGRICULTURE, IN THE SECONDARY SCHOOLS AND IN THE JURIDIC FIELD

Roxana HOROIAȘ, Ana GAVRILESCU, Florentina ULMEANU

University of Agronomic Sciences and Veterinary Medicine of Bucharest, 59 Mărăști Blvd, District 1, 011464, Bucharest, Romania, Phone: +4021.318.25.64, Fax: + 4021.318.25.67, Emails: roxana.horoias@gmail.com; prof\_ana\_gavrilescu@yahoo.com; florentina.ulmeanu@yahoo.com

**Corresponding author:** roxana.horoias@gmail.com

### Abstract

*This paper approaches a difficult issue especially by its originality and complexity, since it involves the application of the same type of research on completely different areas of activity. Based on the idea that nowadays it is increasingly thought that „the school of life” is the one which really matters and that the level of educational training has no longer an important role in the professional achievements, we proposed ourselves to emphasize the concrete results of those working in agriculture, education and legal field, according to their level of specialization. The orientation towards a socio-economic study has determined the selection of some suitable research methods, in order to help us to obtain answers as close as possible with reality. For this purpose, a series of questionnaires, adapted to each individual case, but having a common basis were used. Interviews with 50 people for each of the mentioned branches of activity have been established. All the responses have been then inserted into a database and statistically processed, being obtained three distinct analyzes, which afterwards could be compared to each other, leading to the final findings. Another direction of research has been the one represented by the education awareness, many of the surveyed persons, who oriented themselves to these professions, completing their studies along the way, and afterwards continuing to inform themselves, to learn, to ask other specialized people. Conclusions arising are among the most diverse, but all guides us to the necessity of changing the way of thinking, of education and of its entire aim perception. Motivating people is an aspect that deserves all the specialists in sociology attention, being a phenomenon of real importance for the society we live in and especially for the future of education.*

**Key words:** education, motivation, results, satisfaction degree, thinking

### INTRODUCTION

Educational system has a special place in every society of the civilized world, being the starting point for sustainability, for a global eco-economy [2]. Generally, people are categorized according to their professional training, to their studies.

Statistically, college and/or bachelor graduates from the United States earn, on average, twice as much as those who only have high school degree. Also, their chances of employment are significantly higher [6].

This seems natural to us, the hard work performed in order to accumulate some knowledge being remunerated later, but it seems that isn't always like this. Many times, come forward persons who managed in life without doing this gradually cycle of studies,

and people, especially the young people, are misled. It was reached the point in which agriculture, as basis of the global economy, can't survive on long-term without specialists to assist in the modernization of technological systems, food security and environmental sustainability [1].

Secondary education cycle, that is mandatory in our Romania, is the starting stage, essential for the whole educational process. Continue specialization of teachers, adapting to the new methods and techniques of teaching and communication is a requirement [5].

The legal field, as well as agriculture and teaching in school, is one where changes occur continuously (laws, regulations), so permanent study, continuous updating is needed [3].

In order to achieve results, those working in

these areas must be aware of the need for education, learning (self-motivation), and employers are required to motivate them as they can [4] – financial or otherwise.

## MATERIALS AND METHODS

This study was conducted in three phases, each of the authors interviewing a number of 50 people who work in their own field of activity: agriculture, education and legal.

The questionnaire has included a number of 5 independent variables and 14 questions with answer variants, out of which 9 questions were the response matrix type. In the final part, 5 open questions were put, where the respondents were asked to write down concrete problems of education, labor market assessment methods, but also success/failure of a job employment. These independent variables have been entered in the questionnaire from the desire to find out the characteristics of respondents regarding the importance of education in developing a career, but also their desire or need to continue the professional specialization.

The only condition to be included in the target group of the study has been really working in one of the three mentioned fields of activity.

Five variables have been considered relevant for the interviewed persons: the gender; the age; the living environment (rural or urban); the education level; the status on the labor market.

The study was conducted in several locations around the country, mainly in the Calarasi, Alexandria and Vrancea counties.

For these 9 complex questions, whose purpose was to identify employees thinking about the role of education and about the opportunities it offers, we used the following response options:

- to a very large extent (very pleased);
- to a great extent (pleased);
- to a small extent (less pleased);
- not at all (unpleased).

After the end of the interviewing period, the questionnaires have been analyzed still separately, on areas of activity. Subsequently, the results were centralized and processed by analysis of variance programs, in which were

taken into account the fields of activity, the age groups and the level of satisfaction of respondents, resulting graphs for each area.

## RESULTS AND DISCUSSIONS

Distribution of respondents by gender is shown in Table 1 and it indicates a rather large discrepancy depending on their activity field.

Table 1. Percentage division of the respondents depending on their gender (original)

Field \ Gender	Female (%)	Male (%)	Difference (%)
Agriculture	26	74	-48
Education	72	28	44
Legal (juridic)	54	46	8

The variations are very significant, observing that the male prevails in agriculture, especially women working in education, the situation being balanced only in the legal field.

Depending on age, the data from Table 2 have been obtained.

Table 2. Percentage division of the respondents depending on their age category (original)

Field \ Years	21-30 (%)	31-40 (%)	41-50 (%)	51-60 (%)	> 60 (%)
Agriculture	24	32	17	18	9
Education	28	36	20	8	8
Legal	19	24	22	23	12

The most representative age category of the respondents was 31-40 years, followed by 21-30 years and 41-50 years. We felt that young people's interest for such a study was higher because they are the ones who suffer the most from the current changes of the labor market.

Regarding the location, over 80% of the respondents for agriculture and education are living in rural areas, while for the legal field all persons are leaving and working in urban areas.

The level of education of the people who participated in the study is shown in Table 3. Note that not all the activities calls for higher education.

As it can be seen, the current situation in agriculture indicates that 50% of employees have a university degree or more.

On the other hand, in education and legal field, this is prerequisite for obtaining a job.

Table 3. Percentage division of the respondents depending on their education degree (%) (original)

Degree Field	High school (%)	Post-high school	University (%)	Post-graduate (%)
Agriculture	32	18	42	8
Education	-	8	72	20
Legal	-	-	69	31

For those 8% in education without a university degree, it is under finalization, they appearing now as unqualified substitute teachers.

In Table 4 we have presented the respondents' satisfaction degree on the level of qualification and on the results achieved so far in their professional activity, as a result of education.

Table 4. Percentage analysis of the satisfaction degree with regard to the professional training (original)

Field	Satisfaction degree	Average (%)	Difference (%)	Signe
Agriculture	Very pleased	15.40	-9.48	o o
	Pleased	29.40	4.52	
	Less pleased	38.80	13.92	* * *
	Unpleased	16.40	-8.48	o o
Education	Very pleased	25.00	0.12	
	Pleased	38.40	13.52	* * *
	Less pleased	27.00	2.12	
	Unpleased	9.60	-15.28	o o o
Legal	Very pleased	19.20	-5.68	
	Pleased	42.60	17.72	* * *
	Less pleased	27.20	2.32	
	Unpleased	9.60	-15.28	o o o

Introducing the age parameter, with the categories from Table 2, we managed to make the graphs in Fig. 1-3, separately for each activity. For agriculture, it is shown that there is a big difference between people's satisfaction levels. The extremes, in this case, have values well below average – few people are totally pleased or unpleased, most of them being pleased or less pleased (the middle categories).

In education stands out that the level of satisfaction increases with the advancing age (red and green curves).

As regards the legal field professions, whether we are talking about legal adviser, lawyer or magistrate, it was found after the respondents' feedback that even here, with aging, the satisfaction degree increases, while the dissatisfaction degree decreases (Fig. 3). The rate of very pleased persons is the highest in over 60 years.

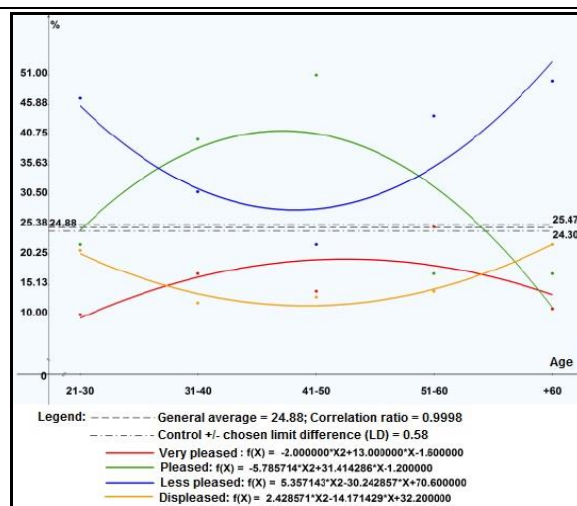

Fig. 1. Graphical representation of the satisfaction degree from agriculture, depending on age (original)

In Fig. 2, the same pattern was made for the responses received from educational field.

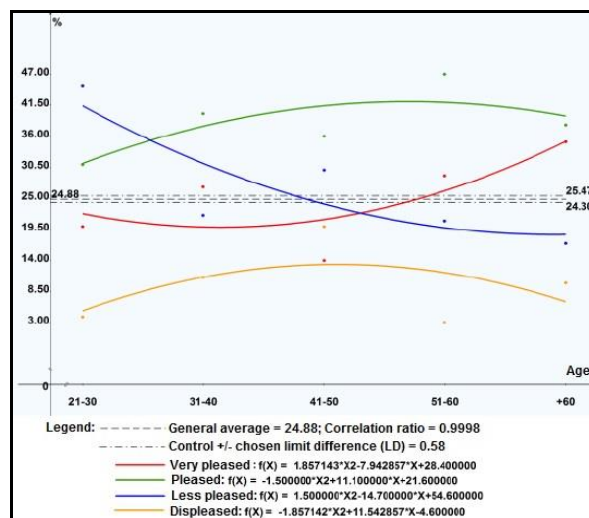

Fig. 2. Graphical representation of the satisfaction degree from education, depending on age (original)

The target group analysis of the satisfaction degree has been considered as relevant, since after the first discussions in this regard, to the questions “To what extent would you be willing to continue your studies, if you were offered the chance?” and “To what extent do you think that professional training/education can help you in your career?”, an additional awareness of the people has been observed. In a 98% proportion, the respondents said that they would like to continue their studies especially because they think that it would be helpful for their future career.

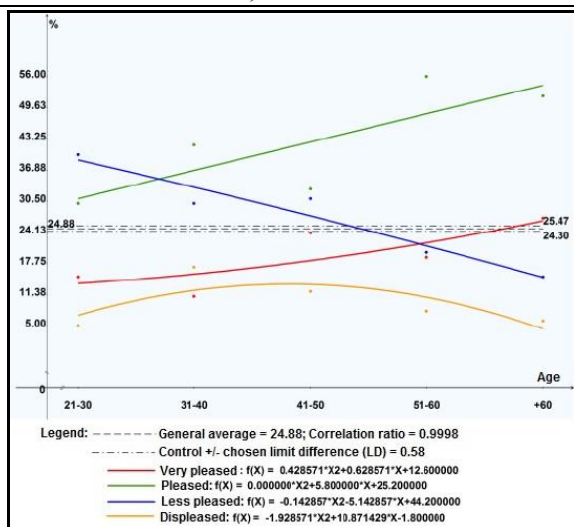

Fig. 3. Graphical representation of the satisfaction degree from legal field, depending on age (original)

At the study have also participated people in all three areas of activity who have completed their studies later in life and who recognized that this became necessary for them in certain circumstances – their own motivation.

The motivating factor for continuing studies was different:

- in agriculture – 72% of the surveyed people have as motivation the possibility of establish own farms and to access EU funds; 25% would like to get a better paid job; 3% have no motivation and no longer want to learn;
- in education – in 95% of the cases a remuneration increase is desired; 5% are those who just want to learn, to be better qualified and to have access to information and higher knowledge;
- in legal field – 81% of the interviewers are motivated by keeping a job; 19% want to have a better reputation.

To all these have been added, in addition, the accumulation of knowledge, meeting some experts in the concerned field of activity or increasing their own reputation among colleagues, followed by involvement in extracurricular projects.

## CONCLUSIONS

It emerges that there are different satisfaction degrees and professional results depending on the activity areas. Thus, in our case the hierarchy is education, law, followed by

agriculture.

Professionals in agriculture reached a rather high degree of awareness of the education necessity, but there is a long way to the implementation of thinking.

In education, professional skills formally obtained are those that prevail over "the school of life". Education and ongoing training importance for young people and adults at any age and in any occupational context should be sustained and promoted.

Juridical professionals know that the learning process is a permanent one for them and they adapted themselves to this.

## REFERENCES

- [1]Acker, D.G., 1999, Improving the Quality of Higher Education in Agriculture Globally in the 21st Century: Constraints and Opportunities, 15th Annual Meeting of the Association for International Agricultural and Extension Education
- [2]Brown, L., 2001, Eco-Economy – Building an Economy for the Earth. Earth Policy Institute, London
- [3]Butoi, T., Butoi, I.T., 2001, Psihologie Judiciara, Ed. Fundatiei Romane de Maine, Bucuresti
- [4]Carré, P., 2000, Motivation in Adult Education: From Engagement to Performance. Proceedings of the 41st Annual Adult Education Research Conference (AERC), Vancouver, University of British Columbia
- [5]Joy, M., 2007, Research Methods in Education (6th edition). Bioscience Education, Vol. 10
- [6]Kezar A. *et al.*, 2008, Why is education important for your future and how can education IDAs help you reach your educational goals?, University of Southern California, SUA

## CURRENT SITUATION AND PROSPECTS OF THE LABOUR ORGANIZATION IN WINE AND GRAPE INDUSTRY IN THE REPUBLIC OF MOLDOVA

**Tatiana IAȚIȘIN, Tatiana COLESNICOVA**

National Institute for Economic Research, Academy of Sciences of Moldova, 45, Ion Creanga Street, Chisinau, Republic of Moldova, MD-2064, E-mail: tatianaiatisin@yahoo.com, ctania@gmail.com

*Corresponding author:* tatianaiatisin@yahoo.com

### **Abstract**

*The labour organization development in Wine and Grape Industry in the Republic of Moldova is analyzed in the paper. The paper highlights the main problems of the manpower in the Wine and Grape Industry in the country using the statistical data provided by the National Bureau of Statistics and the specific system of indicators and methodology. The main directions and prospects of labour organization development in this domain are outlined. Investment in human capital will contribute to strengthen the skills, knowledge in general to facilitate insertion in the viticulture production and wine industry.*

*Key words:* employment in agriculture, labour force, Wine and Grape Industry, vineyards, winemaking.

### **INTRODUCTION**

In developing countries, agriculture is the main employer in rural areas and even in regions where the share of employment in agriculture is lower.

Agriculture continues to influence the rural economy by providing public and semi-public goods, by the aspects linked with environmental protection.

The Republic of Moldova is an agrarian-industrial country. The contribution of agriculture to GDP was about 10.2 % in 2012. Agriculture plays an important role for rural households as agricultural land occupies 75% of the total land area of the country, about 28% of total employment in the country operate in agriculture; the export of agricultural products of local origin in total export makes 49% [4].

The total area of agricultural land at 01.01.2013 amounted to 2,497.8 thousand ha or 73.8% of Moldova's total land area, including  $\pm$  1.8127 thousand ha arable land and perennial plantings  $\pm$  295.3 thousand ha (of which 133.3 thousand ha of orchards, vineyards 149.6 thousand ha, 350.4 thousand ha of pastures, meadows and fallow 2.2 thousand ha 34.2 thousand ha).

### **MATERIALS AND METHODS**

The paper is based on the following system of indicators: surface covered with vineyards in the period 2003-2013 in the Republic of Moldova, the employment in agriculture and food and drinks industry staff occupied in viticulture and wine producing, economic, social and environment aspects of viticulture development.

The data were collected from the National bureau of Statistics regarding employment for the reference period 2006-2013 and the dynamics was interpreted using the usual methods.

### **RESULTS AND DISCUSSIONS**

In recent years, viticulture and winemaking in the Republic of Moldova were said as strategic industries of major importance, which bring more significant contribution to the national economy. For the Republic of Moldova wine is a real country's visiting card. Moldova has a rich winemaking history that has deep roots in human history. According to the data from (2007) of the UN Fund for Agriculture, the Republic of Moldova had the ranks 19 in the world by annual production



volume of grapes. For many years, viticulture and winemaking in Moldova industry is the main aspect of the population's activity.

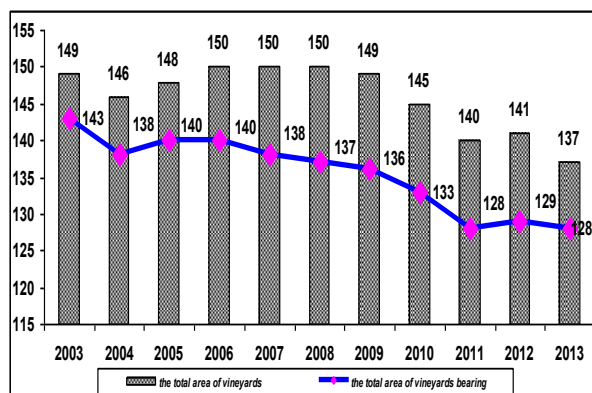

Fig. 1. The dynamics of total surface bearing and vineyards of the Republic of Moldova, during the period 2003-2013, thousand ha

Source: elaborated by the authors based on data from the National Bureau of Statistics, 2013.

In 2010, Moldova had 145 thousand hectares vineyards, of which 133 thousand ha are bearing, vineyard surface in 2003 was 149 thousand ha, of which 143 thousand ha are bearing (Fig.1).

The Wine and Grape Sector provides employment for a large part of the rural population, particularly important in the current alarming increase in unemployment. Compared to other crops, vines require more labor (about 100 days labor / ha). In addition and nursery sector, grapes and bottling grapes also require significant labor. In the Republic of Moldova, about 59% of the population lives in rural areas where about 27.5% of the population is engaged in agriculture. Most people who work in agriculture are self-employed, so even if the share of those employed in agriculture is only 7.2% of the total number of employees (see Figure 2) [5]. In agriculture, labor is used in three ways: the use of family labor; exchange of labor between relatives, friends or neighbors; hiring seasonal or permanent workers.

The number of employed in agriculture fell from 422 thousand persons in 2006 to 338 thousand persons in 2013 - a decrease of 81% (see Figure 2), while in other economy sectors the number of employees is increased (by the cause of migration) [5].

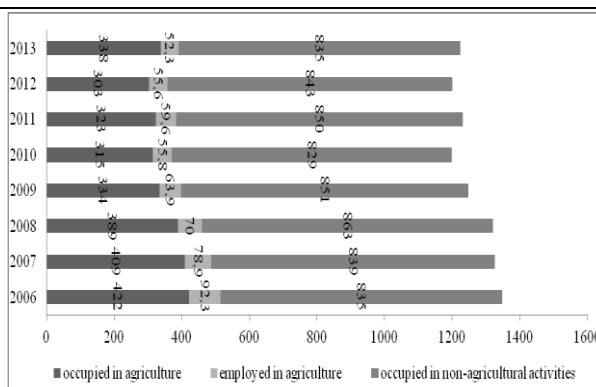

Fig. 2. Distribution of employed in agriculture and non-agricultural activities, during the period 2006-2013, thousand persons

Source: elaborated by the authors based on data from the National Bureau of Statistics, 2013.

There is a little precise information about the number of employees in the Wine and Grape Sector. The only official information about employment in the sector relate to staff at wineries. Overall, it was estimated about 50 thousand persons are involved viticulture, including about 2 thousand - 3 thousand employees in nurseries. This figure is five times higher if we include seasonal workers and small vineyards owners. Industry estimates also indicate that about 4.5 thousand persons are employed in support services such as trade in wine marketing services, manufacturing bottles and cans, transportation, wine tourism and other wine value chain services [2].

Number of employees in food and drinks industry recorded continuous declines. Thus, compared with 2005, the number of employees in this sector fell from 43.8 thousand persons to 26.7 thousand persons in 2011. The biggest fall in staff in the period 2005-2011 occurred in *winemaking industry* – in sugar manufacturing industry from 1.6 thousand persons in 2005 to 1.0 thousand persons in 2011; in the processing and preserving of fruit and vegetables – from 5.1 thousand persons in 2005 to 2.6 thousand persons in 2011, i.e. about 2 times; wine production – from 13.4 thousand persons in 2005 to 5.4 thousand persons in 2011, i.e. about 2.5 times.

An increase in occupied staff in the period 2005-2011, has been documented only in industry production, processing and



preserving of meat and meat products. In some sub-branches, as Manufacturing of dairy products and Manufacturing of cocoa, chocolate and confectionery the average annual number of staff was constant (Table 1) [4].

In the recent years, Wine and Grape Sector has become a major industry that has a significant effect on the national economy as a whole through the following channels:

*Economic aspect:*

- vineyards provide 10-12 percent of the total annual agricultural production;
- wine has great potential, up to 30% of total exports of goods and services is the wine sector;
- weight in wine production is around one quarter of gross domestic product.

Table 1. Average annual number of staff occupied in industrial activities, thousand persons

	2005	2006	2007	2008	2009	2010	2011
Industry - total	125.9	122.2	120.1	115.1	105.4	106.5	89.8
of which:							
Food and drinks industry	43.8	40.4	36.5	35.0	31.7	32.5	26.7
Production, processing and preserving of meat and meat products	2.4	2.5	2.9	3.0	3.0	3.3	2.8
Processing and preserving of fruit and vegetables	5.1	5.0	4.5	4.3	3.1	3.2	2.6
Manufacturing of dairy products	2.9	2.9	2.9	2.7	2.4	2.6	2.9
Manufacturing of grain mill products, starches and starch products	1.6	1.6	1.4	1.3	1.2	1.2	0.4
Manufacturing of bread and patisserie products	6.8	6.8	6.9	7.1	6.9	7.0	5.4
Manufacture of sugar	1.6	1.8	1.5	1.2	0.8	1.0	1.0
Manufacturing of cocoa, chocolate and confectionery	1.3	1.4	1.4	1.4	1.3	1.4	1.3
Distilled alcoholic beverages	2.7	2.3	2.2	2.1	2.0	2.0	1.5
<b>Wine production</b>	13.4	10.5	7.8	7.4	6.2	6.1	5.4
Manufacturing of mineral water and soft drinks	0.9	0.8	0.9	0.7	0.8	0.8	0.7
Manufacturing of tobacco products	1.6	1.3	1.3	1.3	1.1	1.2	1.1

Source: elaborated by the authors based on data from the National Bureau of Statistics, 2013

*Social aspect:*

- all three directions of Wine and Grape Industry are nursery wine vineyard, viticulture and winemaking provides people with permanent jobs for maintenance and higher standards of

living.

*Environmental aspect:*

- growing viticulture enables efficient exploitation of land with a slope grade steeper than 5%, and poor and eroded soils. Vineyards with favorable ecological conditions for growing grapes in the Republic of Moldova is about 350 thousand ha.

In Wine and Grape Industry, as in other branches, there is shortage of qualified staff training for specific skills, with high degree of attractiveness due to migration specialists most attractive branches of economy (from the point of view of career and salary). For example, technical directors, responsible for viticulture of wine producers usually hold degrees in agriculture or viticulture. These graduates were trained in the old style of viticulture, based on Soviet principles of growing grapes and do not have adequate knowledge of international modern technology. The link between vineyards and winemakers administrators is very weak, except the few cases where vineyards owned wine producers. Vineyard workers are employed in permanent and temporary (especially during harvest). They usually live in villages, have low level of education, but with the good experience of working in the field. Workers perform the tasks set but they require careful control and supervision from the directors of vineyards or consultants firm wine producers [6].

**CONCLUSIONS**

The economic growth is linked to the educational growth of the labor force. Investment in human capital through education and health is one of the ways to increase the productivity of the agricultural sector, while improving physical infrastructure is another way. Fox and Porca (2001) suggested that, especially in remote rural areas "management resources in modernizing education and skill level of the local labor force seem to offer much greater benefits than investing in new infrastructure". The development of human resource includes usually a variety of activities from informing

employees about policies and procedures, enterprises (education), going to learn trades and professions for the positions they will occupy immediately (training) and finally, ensuring continuous prospects and challenges for employees, so that they increase their knowledge and skills (development).

Like companies, the enterprises have training functions and are engaged in the act of school education. This system is practiced in the developed countries and is available both for students and specialists' training and its effects are observed by the insertion of graduates of various forms of education.

Investment in human capital will contribute to strengthen the skills, knowledge in general to facilitate insertion in the production environment equipped human resources education and training. Necessary increase the quality of primary and secondary education, and supporting rural girls to continue their studies. Adult education programs (including training, development of technological knowledge, spirit antreprenorial, social competence, language skills, IT skills) must ensure the qualification of rural labor force to increase employment opportunities. People who remain in agriculture must obtain adequate knowledge of management, marketing, production technology, finance and economics, for practicing agriculture becomes a job and a lifestyle.

## REFERENCES

[1]Anuarul statistic al Republicii Moldova, 2011. Biroul Național de Statistică al Republicii Moldova. Chișinău, 2011, 572 pag.

[2]Evaluarea situației curente a sectorului vinicol al Republicii Moldova în scopul elaborării strategiei lui de dezvoltare. Chișinău, 2007. Disponibil: <http://www.vinifera.md/files/Studii/sectorulvinicolmoldova.pdf>.

[3]Kinga, K., Bernadett, P. și alții. Dezvoltarea rurală. Ocuparea forței de muncă în mediul rural. Cluj-Napoca: Accent, 2010, 320 pag. [4]Moroz, V., Poisic, M., Ignat, A., 2012, Managementul riscurilor în agricultura Republicii Moldova. Chișinău, 2012. Disponibil: <http://www.iefs.md/ro/activitatea-iefs/publicatii/255-transformarea-industriei-agroalimentare-n-republica-moldova.html>.

[5]Piața muncii în Republica Moldova. Chișinău, 2012. [http://www.statistica.md/public/files/publicatii\\_electronice/piata\\_fortei\\_de\\_munca/Piata\\_Muncii\\_2012.pdf](http://www.statistica.md/public/files/publicatii_electronice/piata_fortei_de_munca/Piata_Muncii_2012.pdf).

[6]Policica, L., Policica, M., 2005, Resurse umane și pregătirea forței de muncă în mediul rural. Timișoara <http://usabtm.weburl.ro/downloads/cpp/Resursele%pdf>.

## THE LIVING STANDARD AND DEVELOPMENT ANALYSIS THROUGH THE EVOLUTION OF GROSS DOMESTIC PRODUCT FOR THE PERIOD 2000- 2012

Abdul Rahman IBRAHIM<sup>1</sup>, Raluca NECULA<sup>1</sup>, Diana Roxana CAPĂȚĂ<sup>2</sup>

<sup>1</sup>University of Agricultural Sciences and Veterinary Medicine Bucharest, 59 Marasti, District 1, 011464, Bucharest, Romania, Phone: +40 21 318 25 64/232,  
E-mails: ibrahimabdulrahman@hotmail.com, raluca\_nec@yahoo.com

<sup>2</sup>Lund University, Paradisgatan 2, Lund, Sweden, SE-221 00, Phone: +46 (0)46 222 0000,  
Email: diana\_capata@yahoo.com

*Corresponding author:* raluca\_nec@yahoo.com

### *Abstract.*

*This paper aims to highlight the importance of the gross domestic product for the study of an economic area or at the global level, through the analysis of the evolution of this indicator over the period 2000 to 2012. Into the analysis on GDP is analyzed the share that owns agriculture in gross domestic product, the evolution of the GDP growth, the evolution of investments in the studied economic zones, the import and exports of goods and services evolution. All this gives us an overview of the evolution and status of the global economy and in the studied economic areas.*

*Key words:* the average, economic zones, evolution, GDP, average growth rate.

### INTRODUCTION

The phenomena that mark the evolution of the world economy in recent decades stand under the sign of regionalization, globalization of interdependencies and of the interaction.

Numerous studies highlight the heterogeneity of the world economy, adding that between its different areas, gaps remain owing to the uneven development [1].

The Gross Domestic Product (GDP). Is the synthetic expression of economic activity results produced in the economic territory in a period of time, regardless of the contribution that brought the domestic or foreign subjects[4]. Is the market value of all goods and services within a country's borders in a certain period of time, including foreign companies manufacturing operates in the country, but excluding the production of domestic companies abroad.

GDP indicate the strength of an economy by displaying the market value of goods and services produced in an economy in a given year. The main components of GDP are consumption, investment, net exports, and Government property expenditure, of which individual consumption represents about two

thirds of GDP. The GDP deflator index is often used in relation to GDP is to measure changes in the cost of goods and services of a country. An increase in GDP reflect an economic expansion. The increase in GDP of a country to another country, makes the first more appealing to investors. GDP is intended to strengthen the national currency[3].

The Gross domestic product per capita (GDP/capita) is the most widely used indicator in measuring the levels of development between regions, being used by the European Union to measure disparities between regions development, including the indicative financial allocations between its regions as regards cohesion policy[2].

### MATERIALS AND METHODS

After the level of socio-economic development, world States can be grouped into: States with high level of economic development, states with average level of economic development and in developing countries [6].

States with a high level of economic development. The most highly developed States.

"Group of seven".

Small States highly developed in Europe.

Newly industrialized countries ("Asian dragons").

Migratory capitalism States.

States with average level of economic development

Countries with economies in transition: the former socialist countries in Europe, CIS countries and China.

"Key" countries medium developed: Brazil, Mexico, Argentina, Turkey.

Oil-exporting countries (oil monarchies): Saudi Arabia, United Arab Emirates., Kuwait, Qatar, Bahrain, Oman, Brunei.

Developing States.

Countries with more advanced level of development: countries in Latin America, with the exception of those in the Second Group and in Asia (including India, Indonesia, Iran), North Africa and countries in Oceania.

The most underdeveloped countries in the world are 32 African countries, 5 Asian countries from Latin America, Haiti, etc.

**Gross domestic product GDP** can be defined:

a) GDP is the sum of gross added values plus taxes and less subsidies on products;

b) GDP is equal to the sum of final uses of goods and services;

c) GDP is the sum of uses of generation of income account of the total economy [4].

For the arithmetic mean =  $\bar{x} = \frac{\sum xi}{n}$  ;

where:

X = the arithmetical mean; Xi = The average production values for a number of years (i);

n = number of years taken into account

The annual average growth rate [5] =

$r_{2000-2012} = 12\sqrt[12]{\prod(p1/p0)} - 1$ ; where:

$r_{2000-2012}$  = average annual growth rate;

$\prod p1/p0$  = entangled growth indicators

The data come from the statistical bulletins published by the World Bank and are interpreted with the aid of the indicators listed above.

## RESULTS AND DISCUSSIONS

The data presented in table no. 1. set the following situation in terms of the evolution of the GDP/capita:

Table 1. The evolution GDP/ capita evolution on economic zones and worldwide, for the period 2000 to 2012

Economic Zone	MU	2000	2005	Average/Rythm (2000-2005)	2006	2012	Average/Rythm (2006-2012)	Dif(+/-) (2012/2000)		Average/Rythm (2000-2012)
								(+/-)	%	
Arab Countries	USD/loc	2,388	3,498	2,751	4,112	7,197	5,635	2,884	104.86	4,304
	%		1.15	7.93		1.14	9.78	1.85	23.32	9.63
East and Pacific Asia	USD/loc	908	1,629	1,197	1,883	4,916	3,272	2,075	173.33	2,314
	%		1.15	12.41	1.16	1.16	17.35	4.94	39.82	15.12
Euro Zone	USD/loc	22,332	32,675	24,872	34,817	39,518	38,755	13,883	55.82	32,347
	%		1.15	7.91	1.07	0.98	2.13	-5.78	-73.03	4.87
EU	USD/loc	19,522	29,232	22,126	31,275	35,213	34,601	12,474	56.38	28,843
	%		1.15	8.41	1.07	0.99	2.00	-6.41	-76.26	5.04
Highly indebted poor countries (PPTe)	USD/loc	298	410	329	456	769	632	303	92.27	492
	%		1.13	6.59	1.11	1.06	9.11	2.52	38.21	8.23
Less advanced countries (clas ONU)	USD/loc	269	388	307	445	809	647	340	110.56	490
	%		1.14	7.65	1.15	1.08	10.48	2.83	37.05	9.63
North America	USD/loc	34,449	45,016	38,526	46,392	51,800	48,830	10,304	26.75	44,074
	%		1.07	5.50	1.03	1.04	1.85	-3.64	-66.26	3.46
Countries OCDE	USD/loc	23,462	31,652	25,978	33,082	38,262	35,836	9,857	37.94	31,286
	%		1.10	6.17	1.05	1.03	2.45	-3.72	-60.24	4.16
Small Countries	USD/loc	2,356	3,605	2,756	4,113	5,461	4,887	2,131	77.32	3,904
	%		1.17	8.88	1.14	1.06	4.84	-4.04	-45.48	7.26
Southern Asia	USD/loc	448	700	532	782	1,447	1,111	580	109.02	844
	%		1.16	9.33	1.12	1.07	10.81	1.48	15.82	10.26
South-Saharan Africa	USD/loc	496	778	567	893	1,581	1,192	625	110.24	903
	%		1.20	9.41	1.15	1.16	9.99	0.57	6.10	10.14
Worldwide	USD/loc	5,429	7,303	5,980	7,771	10,343	9,070	3,090	51.68	7,644
	%		1.11	6.11	1.06	1.06	4.88	-1.23	-20.12	5.52

Own calculation \*\*\* World Bank, accessed sept 2014, <http://data.worldbank.org/indicator/NY.GDP.MKTP.KD.ZG>

- The Arab countries present a continuing growth throughout the period analyzed, with +

1.15% in 2005 compared to 2000 and 1.14% in 2012 compared to 2006, the rate of increase

in 2000-2012 is of 9.63%;

- The European Union shows an increase of 1.15% in 2005 compared to 2000, in the following period the increases to be more weighted, in 2012 by 0.98%, the annual

growth rate for 2000-2012 is of 5.04%;

- The global value of GDP has a value in 2012 of 10,343\$/capita, with an average 2006-2012 of \$ 9,070/capita and a growth rate for the period 2000-2012 by 5.52%.

Table 2. The size and evolution of the agriculture share in national GDP, on economic zones and worldwide, 2000-2012

Economic Zone	MU	2000	2005	Average/Rythm (2000-2005)	2006	2012	Average/Rythm (2006-2012)	Dif(+/-) (2012/2000)		Average/Rythm (2000-2012)
								(+/-)	%	
Arab Countries	% PIB	8.4	6.6	8.0	6.4	5.2	5.6	-2.4	-42.6	6.7
	%		0.89	-4.71		1.02	-3.40	1.3	-38.4	-3.92
East and Pacific Asia	% PIB	14.9	12.2	13.6	11.4	10.9	11.2	-2.5	-22.0	12.3
	%		0.90	-3.92		0.98	-0.74	3.2	-426.3	-2.57
Euro Zone	% PIB	2.4	1.8	2.2	1.7	1.7	1.7	-0.5	-30.7	1.9
	%		0.86	-5.59		1.00	0.02	5.6	28056.2	-2.83
EU	% PIB	2.3	1.7	2.1	1.6	1.6	1.6	-0.5	-31.5	1.8
	%		0.85	-5.87		1.00	0.02	5.9	29432.5	-2.98
Highly indebted poor countries (PPTE)	% PIB	30.4	28.3	29.3	27.4	26.8	26.9	-2.4	-8.8	28.0
	%		1.03	-1.42		1.01	-0.37	1.1	-285.9	-1.04
Less advanced countries (clas ONU)	% PIB	30.3	25.8	28.3	25.1	25.1	25.2	-3.1	-12.2	26.7
	%		0.97	-3.16		1.01	0.02	3.2	15921.6	-1.56
North America	% PIB	1.2	1.2	1.2	1.0	1.3	1.2	0.0	0.2	1.2
	%		0.92	0.00		0.93	4.47	4.5	100.0	0.67
Countries OCDE	% PIB	2.0	1.6	1.8	1.5	1.6	1.5	-0.3	-20.0	1.7
	%		0.89	-4.36		1.00	1.08	5.4	503.6	-1.84
Small Countries	% PIB	7.6	6.4	7.0	6.3	5.5	5.8	-1.2	-20.7	6.3
	%		0.97	-3.38		0.98	-2.24	1.1	-51.0	-2.66
Southern Asia	% PIB	23.6	19.2	21.3	18.9	18.3	18.7	-2.6	-14.1	19.9
	%		0.98	-4.04		0.97	-0.54	3.5	-653.9	-2.10
South-Saharan Africa	% PIB	17.2	17.1	18.3	16.6	14.8	16.0	-2.3	-14.4	17.1
	%		0.99	-0.12		1.00	-1.89	-1.8	93.8	-1.24
Worldwide	% PIB	4.0	3.4	3.8	3.2	3.1	3.1	-0.7	-21.5	3.4
	%		0.92	-3.20		1.00	-0.53	2.7	-506.0	-2.10

Own calculation \*\*\* World Bank, accessed sept 2014, <http://data.worldbank.org/indicator/NY.GDP.MKTP.KD.ZG>

The share of agriculture in GDP is shown in table no. 2, as follows:

- In Arab countries, the share of agriculture in national GDP occupies values around the

average of 6.7% for the period 2000 to 2012, falls for the entire period from 8.6% in 2000 to 5.2% in 2012;

Table 3. The evolution of foreign investments on economic areas and globally, period 2000-2012

Economic Zone	MU	2000	2005	Average/Rythm (2000-2005)	2006	2012	Average/Rythm (2006-2012)	Dif(+/-) (2012/2000)		Average/Rythm (2000-2012)
								(+/-)	%	
Arab Countries	mil \$	2,640	46,060	15,683	69,506	47,202	58,240	42,557	73.1	44,777
	%		2.16	77.16		0.95	-5.38	-83	1534.7	24.84
East and Pacific Asia	mil \$	45,187	136,243	71,138	162,131	414,705	263,544	192,406	73.0	189,437
	%		1.75	24.70		1.16	14.36	-10	-72.0	18.59
Euro Zone	mil \$	422,956	437,490	276,392	429,214	246,355	341,879	65,487	19.2	314,260
	%		3.50	0.68		1.43	-7.62	-8	108.9	-4.07
EU	mil \$	625,636	769,370	415,129	739,674	294,563	494,495	79,366	16.0	468,627
	%		3.52	4.22		1.06	-12.32	-17	134.3	-5.63
Highly indebted poor countries (PPTE)	mil \$	4,340	8,162	6,241	10,247	32,775	21,318	15,077	70.7	15,278
	%		1.18	13.46		0.99	18.07	5	25.5	16.83
Less advanced countries (ONU)	mil \$	3,993	6,625	7,037	9,807	23,471	17,041	10,004	58.7	13,168
	%		0.79	10.66		1.02	13.28	3	19.7	14.60
North America	mil \$	387,485	164,271	178,331	354,494	362,607	280,272	101,942	36.4	234,226
	%		1.12	-15.77		1.39	0.32	16	4970.5	-0.51
Countries OCDE	mil \$	1,101,508	975,326	660,317	1,237,957	796,661	912,662	252,345	27.6	814,260
	%		2.17	-2.40		1.12	-6.10	-4	60.6	-2.46
Small Countries	mil \$	2,463	5,479	3,846	6,952	10,002	8,972	5,125	57.1	7,096
	%		1.21	17.34		0.87	5.33	-12	-225.1	11.38
Southern Asia	mil \$	4,368	10,836	6,900	25,812	32,386	31,840	24,940	78.3	22,683
	%		1.39	19.93		1.17	3.29	-17	-505.0	16.66
South-Saharan Africa	mil \$	6,577	18,734	12,579	15,914	38,680	31,420	18,842	60.0	24,012
	%		1.66	23.29		1.02	13.53	-10	-72.2	14.60
Worldwide	mil \$	1,319,211	1,358,708	886,917	1,765,344	1,747,346	161,399	728,482	45.1	1,335,059
	%		1.90	0.59		1.11	-0.15	-1	504.5	2.19

Own calculation, World Bank, 2014, Indicateurs du développement dans le monde, <http://data.worldbank.org/data-catalog/world-development-indicators>

- In the EU, the share of agriculture in GDP has a national average of 1.8%, dropping from 2.1 percent in 2000 to 1.6% from 2006 until year 2012;

- Worldwide, in 2012, this value is of 3.1%, and the average for the reporting period is around 3.4%;

- The largest shares in 2012 we can observe in the economic zones of southern Asia (18.3 %), less advanced countries (25.1%) and very poor indebted countries (26.8 %).

In terms of foreign investment, period 2000-2012 was favorable for the majority of the studied areas:

- The Arab countries had growths of foreign

investments from 2,640 million \$ in 2000 to 69,506 million \$ in 2006 and 47,202 million \$ in 2012; the average for this period is situated around 44,777 million \$, with an annual growth rate of 24.84%;

-In East and the Pacific Asia we see significant increases, reaching in 2012 to record 414,705 million \$, nine times more than in the year 2000;

- Foreign investment in the EU countries are dropping, with an annual rate of 5.63%, 2012 recording with 53% less investments compared to the year 2000, namely 294,563 million \$;

Table 4. The evolution of imports of goods and services, on economic zones and globally, period 2000-2012

Economic Zone	MU	2000	2005	Average/Rythm (2000-2005)	2006	2012	Average/Rythm (2006-2012)	Dif(+/-) (2012/2000)		Average/Rythm (2000-2012)
								(+/-)	%	
Arab Countries	%PIB	27.9	35.8	33	36.1	41.5	40.7	8.2	25.11	37
	%		1.01	5.11		1.05	2.35	-2.8	-54.03	3.36
East and Pacific Asia	%PIB	29.3	38	33	37.2	31.1	32.7	0.0	0.09	33
	%		1.02	5.34		0.96	-2.94	-8.3	-155.10	0.50
Euro Zone	%PIB	34.5	34.6	33	36.8	39.8	37.5	4.3	12.87	36
	%		1.05	0.06		1.00	1.31	1.3	2170.52	1.20
EU	%PIB	34.1	34.4	33	36.8	39.5	37.3	4.3	12.93	35
	%		1.05	0.18		1.00	1.19	1.0	577.00	1.23
Highly indebted poor countries (PTE)	%PIB	31.6	39.4	35	38.6	40.1	38.5	3.4	9.77	37
	%		1.06	4.51		1.02	0.64	-3.9	-85.87	2.00
Less advanced countries (clas ONU)	%PIB	31.4	35.9	34	35.6	36.9	35.9	2.4	7.07	35
	%		1.06	2.71		1.00	0.60	-2.1	-77.92	1.35
North America	%PIB	16.2	16.8	16	17.5	18.2	17.5	1.9	12.02	17
	%		1.05	0.73		0.99	0.66	-0.1	-10.16	0.97
Countries OCDE	%PIB	23.3	24.2	23	25.7	28	26.3	3.6	15.65	25
	%		1.05	0.76		1.00	1.44	0.7	89.10	1.54
Small Countries	%PIB	59.2	51.6	56	54.2	56.8	55.7	-0.2	-0.27	56
	%		0.96	-2.71		1.01	0.78	3.5	-128.92	-0.34
Southern Asia	%PIB	15.2	22.7	18	24.6	29.8	26.7	9.1	51.37	23
	%		1.14	8.35		1.02	3.25	-5.1	-61.11	5.77
South-Saharan Africa	%PIB	28.9	31.7	31	33.2	33.1	34.0	2.7	8.54	33
	%		1.05	1.87		0.98	-0.05	-1.9	-102.69	1.14
Worldwide	%PIB	24.9	27	25	28.3	30	28.6	3.6	14.34	27
	%		1.04	1.63		1.00	0.98	-0.7	-40.16	1.56

Own calculation \*\*\* World Bank, accessed sept 2014, <http://data.worldbank.org/indicator/NY.GDP.MKTP.KD.ZG>

Imports of goods and services is an important indicator of economic development analysis, and their reporting, as share in GDP is analyzed in table no. 4, where we find the following:

- In the Arabian countries, the imports have a share around 37% of GDP, with annual growth, with a growth rate of 3.36%, since the year 2000 (27.9 %) up to the year 2012 (41.5 %);

- In the countries of the European Union, the imports are increasing, with a rate of increase

of 1.23% for the whole period, the differences for the period 2000-2005 and 2006-2012 are of 4.3 %, while the average for 2000-2012 is of 35% of GDP;

- Lower values were noticed in the countries from the North America (18.2% in 2012) and Southern Asia (26.7% in 2012);

- Worldwide, the average period is 27% imports of GDP, with an annual growth rate of 1.56%.

Table 5. The evolution of exports of goods and services on economic zones and globally, period 2000-2012

Economic Zone	MU	2000	2005	Average/Rythm (2000-2005)	2006	2012	Average/Rythm (2006-2012)	Dif(+/-) (2012/2000)		Average/Rythm (2000-2012)
								(+/-)	%	
Arab Countries	% PIB	41	53.1	45	54.3	56.4	54.2	9.6	21.47	50
	%		1.30	5.31		1.00	0.63	-4.7	-88.05	2.69
East and Pacific Asia	% PIB	33.2	43.1	36	44.4	33.5	37.8	1.5	4.23	37
	%		1.30	5.36		0.96	-4.59	-9.9	-185.60	0.07
Euro Zone	% PIB	35.1	36	35	38	42.4	39.0	4.2	12.05	37
	%		1.03	0.51		1.03	1.84	1.3	263.02	1.59
EU	% PIB	34.3	35.2	34	37.3	41.4	38.2	4.3	12.66	36
	%		1.03	0.52		1.02	1.75	1.2	237.59	1.58
Highly indebted poor countries (PPTe)	% PIB	24.6	28.2	26	28.6	29.7	28.6	2.6	9.98	27
	%		1.15	2.77		0.97	0.63	-2.1	-77.21	1.58
Less advanced countries (clas ONU)	% PIB	25	28.5	25	28.8	27.3	27.3	2.0	8.06	26
	%		1.14	2.66		0.98	-0.89	-3.5	-133.43	0.74
North America	% PIB	13.2	12	12	12.5	14.8	13.6	1.7	14.33	13
	%		0.91	-1.89		0.99	2.85	4.7	-251.20	0.96
Countries OCDE	% PIB	22.6	23	22	24.4	27.3	25.4	3.3	15.04	24
	%		1.02	0.35		1.01	1.89	1.5	437.51	1.59
Small Countries	% PIB	54.8	52.5	52	56.4	49.2	51.2	-0.9	-1.70	52
	%		0.96	-0.85		0.97	-2.25	-1.4	163.57	-0.89
Southern Asia	% PIB	13.7	19.1	16	20.3	22.4	20.9	5.2	32.79	19
	%		1.39	6.87		1.00	1.65	-5.2	-75.93	4.18
South-Saharan Africa	% PIB	33.9	31.7	32	34.3	31.8	32.5	0.2	0.49	32
	%		0.94	-1.33		0.97	-1.25	0.1	-5.97	-0.53
Worldwide	% PIB	25.2	27.2	25	28.5	30	28.7	3.4	13.27	27
	%		1.08	1.54		1.00	0.86	-0.7	-44.22	1.46

Own calculation \*\*\* World Bank, accessed sept 2014, <http://data.worldbank.org/indicator/NY.GDP.MKTP.KD.ZG>

The exports of goods and services as a percentage of GDP and its evolution are discussed in table 5, from where we can observe the following:

- In the Arabian countries, the exports accounted for 50% of GDP (period average), with an annual growth rate of 2.69%, since the

year 2000 (41%) up to the year 2012 (56.4%).

- In the EU countries, the imports increased with a growth rate of 1.58% for the whole period, the differences for the period 2000-2005 and 2006-2012 are of 4.3 %, while the average for 2000-2012 is 36 % of GDP;

Table 6. The evolution of total GDP growth indices, on economic areas and at the global level, for the period 2000 to 2012

Economic Zone	MU	2000	2005	Average/Rythm (2000-2005)	2006	2012	Average/Rythm (2006-2012)	Dif(+/-) (2012/2000)		Average/Rythm (2000-2012)
								(+/-)	%	
Arab Countries	%	5.1	6.1	4.9	7.2	6.2	5.1	0.14	2.72	5.0
	%		0.670	3.65		1.879	-2.46	-6.11	248.12	1.64
East and Pacific Asia	%	7.5	9.7	8.2	10.8	7.4	9.2	0.97	10.51	8.8
	%		1.078	5.28		0.892	-6.11	-11.39	186.45	-0.11
Euro Zone	%	3.9	1.7	2.0	3.2	-0.7	0.8	-1.19	-157.55	1.3
	%		0.739	-15.30		0.412	-22.38	-7.08	31.62	-13.34
EU	%	3.9	2.1	2.3	3.4	-0.4	0.9	-1.38	-158.20	1.5
	%		0.840	-11.65		0.222	-30.00	-18.36	61.18	-17.29
Highly indebted poor countries (PPTe)	%	2.5	6	4.4	5.9	4.8	5.2	0.85	16.17	4.8
	%		1.091	19.14		1.143	-3.38	-22.52	666.07	5.59
Less advanced countries (clas ONU)	%	4.1	8	5.9	7.6	4.8	6.0	0.05	0.88	6.0
	%		1.127	14.30		1.263	-7.37	-21.68	294.01	1.32
North America	%	4.2	3.3	2.8	2.7	2.3	1.2	-1.63	-139.02	1.9
	%		0.892	-4.71		1.353	-2.64	2.07	-78.57	-4.89
Countries OCDE	%	4	2.6	2.5	3	1.3	1.2	-1.33	-114.61	1.8
	%		0.813	-8.25		0.765	-13.01	-4.75	36.55	-8.94
Small Countries	%	3.7	4.6	4.8	5.5	2.9	3.1	-1.71	-55.74	3.9
	%		0.667	4.45		0.906	-10.12	-14.57	143.99	-2.01
Southern Asia	%	4.1	8.8	6.0	8.7	4.8	7.1	1.09	15.32	6.6
	%		1.158	16.50		0.762	-9.44	-25.94	274.89	1.32
South-Saharan Africa	%	3.4	5.5	5.0	6.8	3.8	4.9	-0.08	-1.61	4.9
	%		0.591	10.10		0.905	-9.24	-19.34	209.24	0.93
Worldwide	%	4.3	3.6	3.1	4.1	2.3	2.4	-0.75	-31.43	2.7
	%		0.878	-3.49		0.821	-9.19	-5.69	61.99	-5.08

Own calculation \*\*\* World Bank, accessed sept 2014, <http://data.worldbank.org/indicator/NY.GDP.MKTP.KD.ZG>

-As in the case of imports, lower values we see in countries in North America (14.8% in 2012) and southern Asia (22.4% in 2012);

Worldwide, the average period is 27% of GDP, with an annual rate of increase of 1.46%.

The growth indices of total GDP are the main indicators in the study of economic development, and their development is shown in table 6, as follows:

- For the Arabian countries the total GDP growth indices have values around 5% share, we see a higher value in 2006 of 7.2%, reaching in 2012 to 6.2%; the annual growth rate is by 1.64 percent;

-For the EU countries, indices are located at shares around 1.5%, the value in the year 2012 being negative-0.4%, the annual decrease is of - 17.29% for the whole period;

- Decreases of indices during the period (annual rate) is seen in North America (-4.89%), Small Countries (-2.01%), the Euro Zone (-13.34%) and at the global level (-5.08) where indices show an average of 2.7%.

## CONCLUSIONS

The uneven development is due to diversify of the development factors; they are the ones that have helped to increase regional disparities. The pace of growth of an area will result in a maximum level of disparity between regions, then these disparities decrease.

The gross domestic product has increased during the reporting period, both at the world level and for all economic areas studied, showing a positive evolution within this indicator of growth in the economy.

Regarding the agriculture as part of GDP, we can notice that the largest shares are found in Southern Asia, also in Less-Developed Countries as well as in Very Poor Indebted Countries. A significant share of the agriculture in the GDP we can see in the Arab countries, the average for the period is of 6.7%.

The foreign investment, a propulsion engine of the economy, have significant increases, as seen in East Asia while those within the EU are slumping. The Arabian countries know a breeder of the investment trend, with steady growths until the last year.

The analysis on imports and exports as share of GDP has highlight the existing gap between the economic zones as well as the North America and South Asia, where both occupy small weights, and the Arab countries,

including the EU's economic zone.

The GDP growth indices have a downtrend for the economic developed areas such as North America and important growths in areas such as Arab countries and East Asia, Very Poor and indebted Countries.

## REFERENCES

[1]The development and location factors of World Agriculture,visited 2014,

[http://biblioteca.regielive.ro/referate/geografie/factorii\\_de\\_dezvoltare\\_si\\_amplasare\\_agriculturii\\_mondiale-153955.html?in=all&s=mpie](http://biblioteca.regielive.ro/referate/geografie/factorii_de_dezvoltare_si_amplasare_agriculturii_mondiale-153955.html?in=all&s=mpie)

[2]The GDP at regional level,,2014,

[http://ec.europa.eu/eurostat/statistics-explained/index.php/GDP\\_at\\_regional\\_level/ro](http://ec.europa.eu/eurostat/statistics-explained/index.php/GDP_at_regional_level/ro)

[3]The gross domestic product,

<http://bulbrokers.com/ro/training/indicatori-macroeconomici/produsul-intern-brut-pib/>

[4]The measuring indicators of results at the macroeconomic level, course Stud.CSIE.seriile SCN, C + D, XI, 19-20, 2008, [www.amaniu.ase.ro](http://www.amaniu.ase.ro)

[5]The World Bank Data, accessed sept 2014,

<http://data.worldbank.org/indicator/NY.GDP.MKTP.KD.ZG>

[6]Typology of world states,

<http://geografiamediuului.blogspot.ro/2015/04/tipologia-stator-lurnii.html>



## THE ROLE OF FAMILY SOCIALIZING IN BUILDING GENDER IDENTITY

Adina Magdalena IORGA

University of Agricultural Sciences and Veterinary Medicine Bucharest, 59 Marasti, District 1, 11464, Bucharest, Romania, Phone: +40213182564, Fax:+40213182888, Mobile:+40721649215, Emails:iorga\_adinam@yahoo.com

*Corresponding author:* iorga\_adinam@yahoo.com

### Abstract

*Socialization is an interactive communication process that requires individual development and social influences, thus highlighting personal reception and interpretation of social messages, as well as the intensity and content dynamic of these social influences. In this context, family socialization represents the main model of the of gender interactions, of defining gender identity composition and gender expectations. Gender socialization within the family setting is very important because it internalizes the gender rules and ideologies, assimilating gender content from the two significant figures : Mom and Dad. This content is a fundamental cornerstone for building gender identity. The research aims to identify the views of students from the Veterinary Medicine University of Bucharest regarding the role of family socialization in the construction of gender identity. The research results confirm a trend of perception for most students towards the innovative socializing model, based on equality in the distribution of tasks within the family. However, there are differences between the genders in terms of perception and comprehension of the role of women and men. Thus, it appears that some of the students believe that the woman carries most of the household domestic tasks, while some students assigned the traditional role of financial support for the entire family to the men.*

*Key words:* family socializing, gender identity, innovative socializing model

### INTRODUCTION

**Socialization** is the "transmission-assimilation process of psychosocial attitudes, values, concepts or specific behavior patterns of a group or a community in a person's formation, adaptation and social integration" (Zamfir and Vlăsceanu, 1993) [4]. Social mechanisms consist mainly of socialization among statuses and learning predetermined roles. In traditional families, the **mother's role** was primarily encompassed in the **emotional / expressive education sphere** (which meets the need of affection to the child); the **father's role** is, specifically, in the **instrumental dimension** (in guiding the child towards the social world, outside the family) (Mihailescu, 2003) [3]. Family socialization is the main model of gender interactions, of defining the composition of gender identity and gender expectations (Grunberg, 2002) [1]. **Gender identity** embodies the acceptance of personal identity as male or female based on assuming biological sex but also of cultural

identity in masculinity or femininity terms (Miroiu, 2003) [2]. By socializing, the individual appropriates what the family and subsequently, society expects from this (gender) form of behavior. The principle of equality between men and women enforces acceptance and highlights differences between them both and the various roles they play in society.

### MATERIALS AND METHODS

The research was conducted at the University of Agronomic Sciences and Veterinary Medicine of Bucharest on a research sample group of 375 respondents. The data collection timeframe was June 1st to July 31st, 2014. The research group comprises 162 female students and 213 male students, with a representative distribution over all the faculties and their components (Agriculture, Zoology, Veterinary Medicine, Horticulture, Biotechnology and Management). *Romanian family is based on a traditional*

model of socialization that is passed on from generation to generation. In this context **the research hypothesis** is as follows: young people have integrated elements of the modern social model, thus modifying traditional social behavior.

The items in the questionnaire with which we want to verify the research hypothesis are presented in Table 1.

Table 1. Questionnaire content

Items
In your opinion, what is key to having a good marriage?
Who does the daily shopping in your household?
Who decides on how money for daily expenses is being spent, in your household?
Who decides how money is being invested, for major purchases (tv, car, etc) in your household?
Who usually does the following activities in your household...
What is your marital status?
Would you live with your spouse before marriage?
Who should be in charge of .... within the family?
Communication between yourself and other family members is...
How satisfied are you about the quality of communication within your family?
How do you react to failure in your everyday life?

Processing and interpretation of questionnaire data and findings was done with the Statistical Package for the Social Program IBM SPSS 10.0 Sciences. In this program the following methods were applied: *Descriptive Statistic – Frequencies; Descriptive Statistic – Crosstabs; Bivariate Correlation.*

## RESULTS AND DISCUSSIONS

### 1.SINGLE VARIATION STATISTICAL ANALYSIS OF THE DATABASE

Respondents showed that in order to have a happy marriage partners must "trust each other" (80.53 %), "love each other" (80.00 %), "to support one another" (79, 2%), "be faithful"( 78.13 %), "have a home of their own" (66.93 %), "be sexually compatible" (56.53 %). Less significant are the following : "a small age gap between them" (22.93 %), "having the same education level" (24.00 %), "having money" (27.20 %). The partnership developed in a marriage is based on mutual valuing each other through trust, love, support, loyalty and only then, home ownership. We note the passing from the marital rational criteria type (money, property) to the psychological and relational, empathetic type (Table 2).

Table 2. The frequency of responses to the statement "In your opinion, what is important for a marriage to be successful ?"

	Very important (%)	Important (%)	Unimportant (%)	Unimportant at all (%)	DK/DA (%)
having a place of their own	66.93	26.67	4.00	1.60	0.80
having good living conditions	48.53	47.20	2.67	0.80	0.80
having money	27.20	60.27	10.93	0.80	0.80
having the same level of education	24.00	45.33	27.73	1.60	1.33
supporting each other	79.20	18.93	1.07	0.27	0.53
being faithful	78.13	20.00	1.33	0.27	0.27
loving each other	80.00	18.13	1.07	0.53	0.27
sexual compatibility	56.53	35.20	6.13	0.27	1.87
trusting one another	80.53	17.07	1.87	0.27	0.27
being of similar age	22.93	37.07	36.27	2.67	1.07

Source : own SPSS processing

To have a happy marriage female students regard partners "having the same education" (+9.27 %), less on (+ 5.81 %) "having a home of their own" , "having money" (+ 5.70 %) and only a few considering "a small age gap between them" significant (+ 4.52 %).

Respondents residing in rural areas consider "having money" (+3.40%) highly more relevant than those respondents in urban areas and then on, "having a home of their own " (3.02%). "Having the same education " is more valued in urban than in rural areas (+ 3.49 %) as well as "trust each other" (+1.66%). Respondents from rural areas values the rational, financial aspects, while those in urban areas cherish the educational and symbolic values.

**Daily shopping** is made by both partners in 58.93 % of families, only by females in 29.33 % of them , while 7.73 % of those who make daily purchases are male. Female students appreciate that their families everyday purchases are made by both partners equally 60.25 %, but also that females do daily shopping to a greater extent within the families than the view of male students(+7.72 %).

The decision on spending **money for everyday necessities** belongs to both partners equally (76.80 %), only to females (13.6 %) and only to males (7.2 %).

Decisions on **important family expenses** are

taken by both partners equally (76% ), just the males (14.67 %) or just the females (6.93 %). Female students say that important decisions are taken by both partners in a higher proportion (+9.06 %), while male students respond that males take important decisions to a greater extent of (+ 9,46%).

We notice that except the cases in which both partners take important or daily decisions together (about 76 %), decisions on daily shopping are taken mostly by females, while important spending decisions are taken by the males.

Housework and domestic activities in the families from which respondents come from are strictly distributed by gender : if the women are mostly "in charge" of the washing /ironing clothes (82.13%), preparing / cooking the food (73,87%), cleaning up the house (70.67%), washing the dishes (64.80%), daily care of the child / children (43.73%), household care (31.47%), the men have specific designated tasks also, such as fixing / repair work on the household installations and facilities (plumbing, electric appliances, etc.) in an average of 80.27 %. The activities both women and men alike do are: daily care of the child / children ( 41.33 %) and household care (43.13 %) ( Table 3).

The vast majority of respondents cohabit (57.07%), or are single (38.13%). The number of married, divorced or widowed is reduced. The relational model accepted by students during their studies period is cohabitation. The percentage of male students living as a couple is high (5.59 %), while the percentage of married female students is higher than married male students (+ 2.62 %).

Table 3. Frequency of responses to the question "Who often does the following activities in your household ?"

	More often the woman (%)	More often the man (%)	Man and woman equally (%)	Hiring someone (%)	Not the case (%)	DK/DA (%)
takes care of the housekeeping	31.47	20.00	34.13	1.87	11.47	1.07
fixes household appliances (plumbing, electrical, etc.)	2.93	80.27	6.93	7.47	1.60	0.80
food preparation	73.87	3.73	21.33	0.53	0.53	0.00
housecleaning	70.67	3.20	24.27	1.33	0.53	0.00
doing the laundry	82.13	2.93	13.60	0.80	0.00	0.53
washing the dishes	64.80	5.33	28.53	0.53	0.80	0.00
daily care for the children	43.73	2.13	41.33	1.87	9.87	1.07

Source : own SPSS processing

Respondents from urban areas adopt cohabitation to a greater extent (+8.08 %), while those in rural areas are mostly single (+7.95 %).

55,20 % of the respondents agree with living together before marriage, 21.33 % answered that they were not married, while only 7.73 % do not wish to live together before marriage (Table 4).

Table 4. The frequency of responses to the question "Would you live with your husband / wife before marriage ?"

	(%)
Yes	55.20
No	7.73
Never been married	21.33
DK/DA	15.74

Source : own SPSS processing

Male students approve of living together before marriage to a larger degree (2.63%) than female students. Respondents in urban areas also mostly prefer living with their future spouse before marriage (4.92 %), while rural respondents frown upon living with their husband/wife before marriage(+1.28 %).

**Care and moral support** between spouses should be equally provided (87.47 %), they should also **manage the family income** together (83.20 %), equally on dealing with **childcare** (78.67 %), as well as **looking after the elderly** (77.60 %).

But household and domestic chores should be handled by both parents equally (63.20%) or more by the mother (33.07 %), while gaining revenue and providing for the family can be the responsibility of both parents equally (68.80%) or more the father's concern (28.80 %) (Table 5).

Opinions of respondents indicate a greater adherence to the democratic, innovative family model, in carrying out the basic functions, but also a reminiscence of the rooted traditional model of dividing and distributing family roles.

Table 5. Perception on gender roles

Who in the family should be in charge of ...	Mostly the mother (%)	Mostly the father (%)	Both parents equally (%)	Other (%)	DK/DA
1. raising children?	19.47	1.87	78.67	0.00	0.00
2. earning an income?	2.13	28.80	68.80	0.27	0.00
3. housekeeping?	33.07	3.73	63.20	0.00	0.00
4. taking care of the elderly?	13.60	1.87	77.60	5.87	1.07
5. moral support?	7.20	4.80	87.47	0.53	0.00
6. managing the family finances?	6.13	10.40	83.20	0.27	0.00

Source : own SPSS processing

In gender formation a primordial role is played by the family educational factor. The educational factors leading to the formation of gender identity as a boy are: discipline (81.33 %), freedom of choice (40.80 %), order(31.20 %). In the family education of girls, the key aspects are: discipline (45.60 %), diligence(48.27%) and obedience(36.80%). If discipline is valued in the education of both genders, freedom of choice and order is more of an imperative for boys, while as for girls, diligence and obedience become paramount (Table 6).

Table 6. The frequency of responses to the question "What are the most important things in the education of boys / girls?"

	For boys (%)			For girls (%)		
	YES	NO	DK/DA	YES	NO	DK/DA
1. discipline	81.33	18.13	0.53	45.60	54.40	0.00
2. diligence	26.40	73.33	0.27	48.27	51.73	0.00
3. obedience	20.27	79.73	0.00	36.80	63.20	0.00
4. freedom of choice	40.80	59.20	0.00	36.00	64.00	0.00
5. order	31.20	68.80	0.00	32.00	68.00	0.00

Source : own SPSS processing

Respondents appreciate communication between family members as very good (54.40 %), good (34.67%) and satisfactory ( 8.27 %). A small percentage of only 2.13% consider family communication as unsatisfactory and in need of improvement (Table 7).

Table 7. The perception on family communication

Communication between yourself and other family members is...	%
Very good	54.40
Good	34.67
Satisfactory	8.27
Unsatisfactory	2.13
DK/DA	0.53

Source : own SPSS processing

Among the family members that are very satisfied with communication within the family are those that have it with their mother (61.07 %), then their father (47.47 %). Of those who have siblings, very satisfied are those getting along well with their sister (21.33 %) and those with their brother (17.60 %) of respondents (Table 8).

Table 8. Satisfaction levels on communication with family members

	Very satisfied (%)	Satisfied (%)	Less satisfied (%)	Unsatisfied (%)	Not the case (%)	DK/DA (%)
Mother	61.07	32.00	4.27	1.60	0.27	0.80
Father	47.47	33.07	8.27	4.00	5.87	1.33
Sister	21.33	16.00	2.93	1.60	56.80	1.33
Brother	17.60	13.07	5.87	2.67	57.87	2.93
Others	2.13	2.67	0.00	0.00	1.07	94.13

Source : own SPSS processing

In case of failure, respondents say they react through calming down on their own (42.13 %), depression (25.60 %), irritation (25.07 %), determination (15.73 %), indifference (10.13 %), anger (6.93 %), hopelessness (3.20 %), disdain (2.40 %) ( Table 9).

Table 9. The frequency of responses to the question "How do you deal with failure in your daily life ?"

	Yes (%)	No (%)
Indifference	10.13	89.87
Calming down	42.13	57.87
Annoyance	25.07	74.93
Fury	6.93	93.07
Despair	3.20	96.89
Depression	25.60	74.40
Determination	15.73	84.27
Other ...	2.40	97.60

Source : own SPSS processing

## 2.VARIABLES ASSOCIATION EVALUATION REGARDING FAMILY SOCIALIZATION

### Gender analysis

The analysis of the variables on family socialization through their correlation with respondents' gender emphasizes the following:

- there is a statistically significant association between gender and the person doing the daily family shopping (  $\chi^2 = 6.242$ ,  $p = 0.044$ ) - *though most students say that both partners participate in daily shopping, female students believe this activity is especially by the women;*
- there is a statistically important association between gender and the deciding factor on major family expenses  $\chi^2 = 7.046$ ,  $p = .030$  - *both female students and male students assign this role to both partners, but the difference lays that this concept is higher among female students, while more male students consider this role as belonging to the man;*
- there is a statistically relevant association between gender and household caregiver functions (  $\chi^2 = 7.833$ ,  $p = .020$  ) - *even though about a third of the students assign this role to both partners, there is a clear trend of female students to consider the role as attributed mainly women;*
- there is a statistically relevant association between gender and the person doing the dishes (  $\chi^2 = 9.480$ ,  $p = .009$  ) and also a very weak, direct correlation (coef. 0.160,  $p <$

0.002) of notable characteristics - *there is a distinctive form distribution of this role family, female students tend to attribute this role to mostly women, while male students assign it to both partners;*

- there is a statistically significant association between gender and the persons who consider that they're in charge of children education within the family ( $\chi^2 = 14.347$ ,  $p = .001$ ) and a very weak correlation, reversed, but notable (coef.  $-0.197$ ,  $p < 0.001$ ) - *both female and male students assign this role to both partners, but the difference comes from the fact that male students consider this role more often a woman's field of functions;*

- there is a statistically considerable association between gender and the person who is views as responsible for ensuring the family income ( $\chi^2 = 14.794$ ,  $p = .001$ ) and a weak correlation, reversed, but notable (coef.  $-0.201$ ,  $p < 0.001$ ) - *both female students and male students assign the role to both parents, but male students consider that this role belongs to the father to a greater extent;*

- we observe associations and correlations between gender and responses to failure, as indifference ( $\chi^2 = 8.453$ ,  $p = .004$ ; a very poor correlation, reversed coef. of  $= -0.150$ ,  $p < 0.004$ ) and as depression ( $\chi^2 = 10.442$ ,  $p = .001$ ), along with a very poor correlation, direct coef. of  $= 0.167$ ,  $p < 0.001$ ) - *we notice that female students react to failure more often in the form of depression, while male students react to a greater extent than women with indifference.*

#### **Analysis based on resistance**

Analysis of the variables on family socialization through their correlation with the residence fortitude of respondents, emphasizes the following:

- generally there are no statistically important differences between respondents, which underlines the uniformity in behavior among young people, with their integration into the specific social environment of student life;

- there is a significant correlation showcased, statistically weak and reversed, in terms of role responsibilities, in considering that raising children must be done by both parents equally;

- There is an association between the

residence sphere and communication within the family, especially with the mother - the association between variables is statistically significant (at a significance level below 0.05), and the correlations are very weak, intense and relevant - *in rural areas, communication in the family and especially with the mother is much better than in the life of urban youth.*

#### **CONCLUSIONS**

As prior noted, there are no major differences between respondents, thus falling within the assumption of social integration of youth in their current environment, that of student life. Statistically significant results however are:

- gender and the person making the daily family shopping runs - *although most students say that both partners participate in daily shopping, female students believe that this activity is mostly reserved for women;*

- gender and important family purchases - *both male students as well as female students assign this role to both partners, but the difference is that this equal division perception is higher among female students, while many male students consider this the role the man;*

- gender and household caregiving - *although about a third of the students assigned this role both partners, there is an obvious tendency of female students to believe that this role has been particularly reserved for women;*

- gender and the person doing the dishes - *there is a different distribution of this role in the family, the female students tend to attribute this place especially towards women, while male students attribute it to both partners;*

- gender and the person considered as the main educational figure for children in the family - *both male and female students assign this role to both partners, but the difference lays in male students' belief that this is mostly the role of women;*

- gender and the person who is considered responsible for ensuring the family income - *most of the female and male students evenly assign the role to both parents, but students consider to a greater degree that this role has*

*to be assumed by the father figure;*

- gender and reactions to failure, both in the form of indifference or depression - *we observed that female students usually react to failure by feeling depressed, while male students react to a greater extent than women through indifference.*

- the residence field and family communication, especially with the mother - *we notice that especially in rural areas, communication with family members, and with the mother in particular is way better than in the urban environment and background.*

***The initial hypothesis on which we built our research was that young people have integrated elements of the modern social model, inadvertently modifying traditional social behavior.***

***Statistical results confirm the tendency of most students to adhere to the social innovative model, based on equality in distributing family tasks.***

***All this considered, there are still differences between gender when it comes to the perception of the role of man and woman. Thus, on one hand we notice a part of the female students that considers women in charge of domestic chores and housekeeping as well as raising children, while the man is responsible for financial support and providing for the family.***

## REFERENCES

- [1]Grunberg, L., 2002, *Revoluții în sociologia feministă. Repere teoretice, contexte românești*, Publirom
- [2]Mihăilescu, I., 2003, *Sociologie Generală. Concepte fundamentale și studii de caz*. Ed. Polirom, Iași
- [3]Miroiu, M., 2003, *Politici ale echității de gen. Ghid pentru învățământul universitar din Europa Centrală și de Est*. Politeia–SNSPA, București
- [4]Zamfir, C., Vlăsceanu, L., 1993, *Dicționar de sociologie*. Editura Babel, București

## ECONOMIC ANALYSIS OF STATE AND DEVELOPMENT OF BEEKEEPING IN BULGARIA

Vasko KOPRIVLENSKI, Violeta DIRIMANOVA, Valentina AGAPIEVA

Agricultural University – Plovdiv, Department of Management and Marketing, Plovdiv 4000, 12 Mendeleev Blvd, Plovdiv, Bulgaria, Phone: +359 32 654 437, Email: koprivlenski@au-plovdiv.bg, violeta\_dirimanova@yahoo.com, agapieva@au-plovdiv.bg

*Corresponding author:* violeta\_dirimanova@yahoo.com

### Abstract

*The aim of this paper is to analyze the trends and development of Bulgarian beekeeping. The study is based on official statistical data of the Ministry of Agriculture and Food and fieldwork study for the period 2009-2012. To achieve the above aim, first of all, the authors trace the changes in the production of honey until 2012 and second they analyze the distribution of farms according the number of bee colonies and prophylactic methods of their feeding up. In addition, in study was revealed the reasons for distribution of the bee colonies and identified the important problems facing the sector in term of the legislation, protection of the bee colonies, the control of the importing the queen bees and market development of the bee products. The one of main results of the study showed that the number of bee colonies in the country decrease even highly expert-oriented production of honey in Bulgaria.*

*Key words:* beekeeping, Bulgaria, economic development, honey production

### INTRODUCTION

Beekeeping is organized production of honey and other bee products such as bee pollen, beeswax, propolis, bee venom. The main benefit of beekeeping, however, is not honey, as is often emphasized, and the pollination of wild and especially cultural vegetation, leading to the multiplication yields.

Accordingly, it can be said that the honey bee is in the by-product. Without pollination there would be total starvation of animals and people and life on our planet would be endangered. To the favorable climate, a wide variety of honey plants and the overlap of beekeeping in the economic life of the camp, define Bulgaria as typical beekeeping country. The goal of this study is to analyze the trends and development of beekeeping in Bulgaria. Therefore, we study the amendment in honey production, bee colonies' distribution and also outline the main problems in the sector.

### MATERIALS AND METHODS

The economic analysis of the status and development of beekeeping in Bulgaria for

the period 2009-2012 is based on a study of the factors influencing the trends and developments of apiculture in Bulgaria, the economic importance of the production of honey in the country, as well as changes in the number of animal colonies for the period. Necessary for that purpose includes official statistics of the Ministry of Agriculture and Food of Bulgaria, as well as the author's own research.

### RESULTS AND DISCUSSIONS

Development of beekeeping as livestock subsector provides both additional income and alternative employment for the population of the less developed rural areas in Bulgaria. [2, 3]

The current economic situation in the country leads to serious changes and structural reforms in beekeeping. There is a tendency of reducing the production of honey in 2012 compared to previous years of the period (Figure 1).

In establishing the amount of honey produced and the number of colonies grown into account the division of the country's economic

development, since the purpose of the study is to analyze the developments and trends of beekeeping, and in different areas, it is rather influenced by the economic situation of Bulgaria.

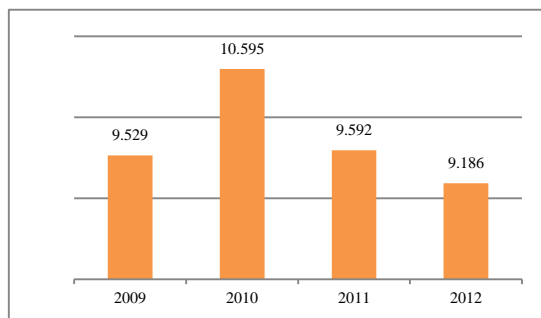

Fig. 1. Honey production (in tons) during the period 2009-2012 in Bulgaria

Source: Annual report, MAF (2011) [1]

As a result of favorable weather conditions, the average yield of honey in 2011 is 20 kg of a royal family. Harvested amount of honey in 2011 is 9,592 tons, which is 9,5% - less than extracted honey in 2010. The greatest amount of honey – 1,188 tons and most grown colonies – 50,435 are in North Eastern region of Bulgaria.

In terms of apiaries in producing honey, also found a decreasing trend, which affects the yield of honey (Fig. 2).

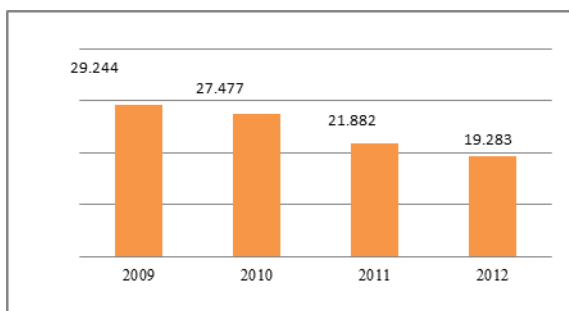

Fig. 2. Number of farms during the period 2009-2012 in Bulgaria

Source: Annual report, MAF (2011) [1]

Most bee farms are in the North Western region – 21.2%, while the smallest number in the southwest region. North region has the highest average number of colonies per farm - 35 pieces. In the North Central region are grown 18.4% of bee colonies. In 2011, this region has the highest average yield of honey compared with other regions, where 23 kg of

a royal family.

Honey in Bulgaria is an agricultural product with a strong export orientation.

In the conditions of tough competition, Bulgaria has established foreign markets mainly in the European Union. The greatest amount of honey is exported to Germany, Greece and Poland, and at least for Italy, Austria and Belgium. In 2012, exports of honey amounted to 9,314.1 tons totalizing 31.8 million USD. Accordingly, the average export price per tonne was 3,419 USD/tonne. Since domestic production of honey meets Bulgarian market year-round, not having the country adds to the agricultural product. Unfavorable prices of bee pollen and royal jelly, forcing beekeepers to implement them in domestic markets. Bee venom is also hardly exported.

For the period 2010-2011, there was a negative trend in quantity sold honey in the industry, but at the expense of the trend of increasing the average cost per conversion of honey (Table 1).

Table 1. Realization of honey and average selling prices in Bulgaria during the period 2010-2011

Type of realization	2010 (tone)	Average price (BGN/kg)	2011 (tone)	Average price (BGN/kg)
Sales of processing plants	3,637	3.93	3,958	3.99
Sales to industry	156	3.82	188	3.69

Source: Annual report, MAF (2011) [1]

Larger share of sales of processors (42,5%), where there is a tendency of increase in the selling price. At the same time, the proportion of sales of honey for cosmetic and pharmaceutical use is quite low (2%). In recent years, the amount of propolis and wax were increased. The price of propolis was increased by about 20% precisely because of its use in cosmetic and pharmaceutical industries.

The disease is widely distributed during the period 97% of beekeepers keep resisted the reduction or elimination.

The number of treatment against Varroa bee colonies in 2011 decreased by 10.8% compared with 2010. Not treated against Varroa 4,344 colonies. The costs of prevention of Varroa in 2011 with the amount



of 6,12 BGN for a royal family, which is more by 69.5% compared to 2010 (Table 2). In the spring of 2010 have burnt 94.9% of all colonies. The number of bee families fed in winter 2010-2011 year is 7.7% less than fertilizing in the winter of 2009-2010. The highest cost of winter feeding – 9.60 BGN for a royal family, and the lowest in spring-7.51 BGN.

Table 2. Prophylaxis and nourish the colonies in Bulgaria in 2010 and 2011

Activities	2010		2011	
	Bee colonies (number)	Average cost of 1 bee colony (BGN)	Bee colonies (number)	Average cost of 1 bee colony (BGN)
Treatment against Varroa	606,949	3.61	541,568	6.12
Winter feeding	407,927	9.28	530,779	9.16
Spring feeding	570,840	8.87	620,652	7.51
Autumn feeding	496,179	8.95	577,216	9.60

Source: own calculation

To ensure normal development of bee colonies in winter when there is no pasture, they need to nurture further. These honey bees obtain the necessary wintering proteins, fats, vitamins and other substances.

In our opinion, one of the strongest factors that have a negative impact on the development of beekeeping in Bulgaria is the parasitic Varroa disease. It is the most severe disease, causing damage to both larvae and bees.

As regards the practice of transhumance in Bulgaria for the period, we found that the proportion of beekeepers still remains low compared to the total number (3.5%).

Major disadvantages are the fragmentation of farms, lack of bee pollination market and some problems with the poisoning of the bees in the conduct of plant protection measures.

Increased transport costs and requirements for the issuance of veterinary certificates also influenced this negative trend.

In 2011, a total of 478 farms practicing transhumance, which is 59% less than in 2010. The number of bee colonies where farmers have practiced mobile beekeeping is 33,685, which is 41.3% less than the previous period. Transport costs and issuance of veterinary certificates increased by 23.3% compared with 2010 (Table 3).

Table 3. Mobility apiculture in Bulgaria during the period 2010-2011

Characteristics	2010	2011	Amendment 2011/2010 (%)
Number of bee colonies	57,356	33,685	-41.3
Number of farms	1,166	478	-59.0
Costs of transport and veterinary certificates (BGN/bee colony)	13.62	16.65	22.2

Source: own calculation

At the time of the study the high mortality and the disappearance of honeybee colonies like syndrome CCD (Colony Collaps Disorder) stands out as an extremely serious problem in Bulgarian beekeeping. Main reasons for the destruction of bee colonies are gassing, starvation, disease and other causes (Fig. 3).

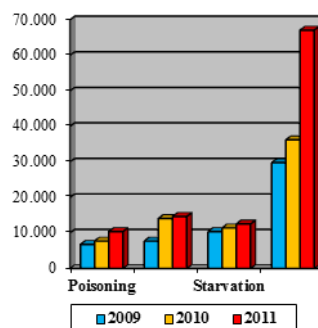

Fig. 3. Destroyed bee colonies during the period in Bulgaria

Source: own calculation

The study shows that in comparison with 2010, in 2011, destroyed by 50.3% more colonies. The number of destroyed otherwise colonies increased by 85.3%, from 36.6% poisoning. Died of starvation 9.8% more colonies. When comparing the data for the three-year period, found that in 2011 the colony losses are highest.

Crucial for the development of production and marketing of honey in Bulgaria is the storage of the finished product. Bulgarian beekeepers honey stored mainly in tins – 66.3% and in glass jars – 56.7%. Some 7.5% use plastic containers or any other packaging other than above.

In 2011, the lowest average price for storage of 1 kg honey (including transport and storage costs) in plastic - about 0.40 BGN/kg, while the storage of one kilogram of honey in tins cost beekeepers around 0.52 BGN/kg. The cost of storage in glass jars were 0.50 BGN/kg, and in packaging other than those

listed 0.42 BGN/kg.

To 2012 continued implementation of the second three-year National Beekeeping Program, applicable for the period 2011-2013. There is a budget of BGN 6,532,501 from which beekeepers have been paid BGN 5,367,783 million, i.e. 82% down in utilization of the allocated funds. [4]

According to us, Bulgarian beekeeping requires the introduction of new technologies, better control of the health status of colonies and measures to promote the realization of bee products.

We believe that the consumption of honey in Bulgaria is inherently weak, despite his health, taste and medicinal qualities, the average annual consumption per person of households do not exceed 300-400 grams. This amount does not include consumption in catering and use in the confectionery and pharmaceutical industries. For comparison, in the EU countries where the consumption of honey per year is averaged about 2 kg/person. However, the results of this economic analysis of the status and development of beekeeping in Bulgaria give us a reason to highlight important problems such as needed law for beekeeping, which along with additional legislation, cover all activities in the beekeeping sector. Poisoning of bees with pesticides also is a significant economic problem in Bulgaria.

Despite the existence of these problems, beekeeping in Bulgaria is included in the programs of the State Fund of Agriculture, measures in the National Beekeeping Program and the Program for Rural Development.

## CONCLUSIONS

The result of the study showed that the number of bee colonies in the country decrease even highly expert-oriented production of honey in Bulgaria. There several problems for this negative result:

First, the lack of bee pollination market and exploration period is under consideration of the importance of this issue by the Bulgarian institutions.

Second, the internal and external market of bee products in Bulgaria is insufficiently

developed.

Third, the growing consumption of preferential loans allows Bulgarian professional beekeepers to increase investment through purchase of modern beekeeping techniques and technologies, implementation of mobility apiculture and new systems of beehives.

## ACKNOWLEDGEMENTS

The study is financed by the Fund "Scientific Research" of the Agricultural University – Plovdiv, Bulgaria.

## REFERENCES

- [1]Annual Report on the Development of Agriculture, Ministry of Agriculture and Food, Agricultural Report 2011, 52-55
- [2]National Strategy for Sustainable Development of Agriculture in Bulgaria in 2007-2013, 263-279.
- [3]Programme for Rural Development for 2007-2013.
- [4]State Fund of Agriculture, "National Beekeeping Program" for the period 2011-2013.

## MACROECONOMIC DETERMINANTS OF THE DYNAMICS OF INVESTMENT IN AGRICULTURE (CASE OF POLAND)

Dariusz KUSZ<sup>1</sup>, Stanisław GEDEK<sup>1</sup>, Ryszard KATA<sup>2</sup>

<sup>1</sup>Rzeszów University of Technology, Faculty of Management, al. Powstańców Warszawy 12, 35-959 Rzeszów, Poland, E-mails: dkusz@prz.edu.pl; gedeks@prz.edu.pl

<sup>2</sup>University of Rzeszów, Faculty of Economics, ul. Ćwiklińskiej 2, 35-601 Rzeszów, Poland, E-mail: rdkata@univ.rzeszow.pl

**Corresponding author:** dkusz@prz.edu.pl

### Abstract

*In an era of increasing competition and the need to meet increasing consumer demand for food quality and safety, as well as the obligatory requirements of sanitary-hygienic and environmental protection, or the need to meet the challenges of climate change and increasing demand from a growing world population, agriculture requires significant investment. Investment activity of farmers depends on many determinants related to both the agricultural farm and its socio-economic environment. The aim of the study is to identify the macroeconomic factors determining the dynamics of investment in agriculture on the example of Poland. It was found that the factors determining the dynamics of investment are mainly factors of demand nature.*

**Key words:** investments, macroeconomic's determinant, agricultural sector

### INTRODUCTION

Agricultural production is a function of several inputs, including the current level of capital (buildings, machinery and equipment, land), which depends on past investment decisions. Investments realized in a specific period create conditions for achieving required future outcomes [16]. Because of that, the investment demand of farmers affects their future production capacity, the level of competitiveness and operational efficiency, market power, and the level of modernity and innovation. In addition, investments in agriculture are one of the most effective ways of reducing poverty and enhancing environmental sustainability. Especially now in an era of growing demand for food, the need to eliminate hunger and making agriculture sustainable will require increased investment in agriculture. At the same time, these investments should aim towards technologies favoring the protection of the environment, resources, agro-ecological and social balance, these should not be investments that promote industrial agriculture.

Domestic private investments play dominant role in the investments in agricultural sector

[1], especially in low- and middle-income countries. Farmers are investing to increase or diversify sources of income, and thus build-up their wealth. Identifying the factors that influence investment demand of farmers, their willingness and ability to invest should be determined in the first place. The tendencies of farmers to invest are psychological and economic motives that inspire to development activities, which is the essence of creation of investment funds. The ability to invest is a measure of the actual investment effort and is an expression of the decision facing the future. Farmer propensity to invest is an expression of his willingness to devote part of disposable income obtained to development and investment capacity is manifested in concrete decisions. Primary importance for the realization of the investment in a farm is farmer's tendency to invest, which - if strong - can be materialized in concrete investments, provided owing the ability to invest.

Factors influencing the propensity and ability of farmers to invest can be divided into two groups: exogenous and endogenous factors. The exogenous factors affecting farmers' investment activities may include [3, 10, 12] factors of demand nature, the expected and the current level of prices, supply conditions, and

in particular the level of costs incurred, current and future economic conditions, geographic and socio-demographic conditions, system solutions (financial, economic, institutional), economical policy of the government, especially the agricultural, fiscal, monetary policy, inflation that underlies the cost of capital, the degree of openness of the economy (especially international trade, flows of financial capital and human factor, participation of the country in various international systems), barriers to international trade regulations especially in the field of environmental protection and preservation of animal welfare, demands and other environmental groups. The endogenous factors are factors related to the potential of the agricultural holding, its equipment in the factors of production, the level of consumption of fixed assets, the level of modern manufacturing techniques used, the level of knowledge of managing agricultural holding, their age, economic - financial situation of farms, etc. [4, 8, 9]. Information reaching a farm from the external environment and internal factors permit the evaluation of the risks associated with the proposed investment project. Adopted by the company hierarchy of objectives of the action together with established set of information allows making a decision on the implementation or failure of the investment. In a study on the factors of agricultural development it is difficult to grasp the role of single factor, because they are closely interrelated and impact the development in a synergistic manner. However, it appears that greater role in stimulating investment activity of farmers is played by exogenous factors. It is difficult to imagine a situation that the farmer guided by the needs of agricultural farms makes investments at unfavorable external factors.

The aim of the study is to identify the macroeconomic factors determining the dynamics of investment in agriculture on the example of Poland.

## MATERIALS AND METHODS

The empirical material was statistical data

from the Central Statistical Office of Poland for the years 1990 - 2012. Time range of analysis was dictated by the fact that in 1989 the Polish transformation took place that has been associated with the transformation of the political system (implementation of democratic institutions and procedures) and economic transformation (replacing the economy centrally planned by free market economy). Due to the different principles of operation of the Polish economy, statistical data from before 1990 may not be comparable with data from 1990.

According to statistics massive investment are considered financial or in kind, whose goal is to create new fixed assets or the improvement (rebuilding, enlargement, reconstruction or modernization) of existing assets, as well as the so-called investment in first equipment.

The value of investment in agriculture is expressed in constant prices of 2011, making adjustments based on price indices of goods and services purchased by private farms intended for investment.

To identify macroeconomic factors affecting the investment activity of farmers, a multiple regression equation of the general form was used:

$$Y_t = \beta_0 + \sum_{j=1}^k \beta_j x_{tj} + \sum_{j=1}^k \gamma_j x_{t-1j} + \varepsilon_t \quad (1)$$

where:  $Y_t$  – endogenous variable in time  $t$  ( $t = 1, 2, \dots, T$ ),  $x_{t1}, \dots, x_{tk}$  – exogenous variables in time  $t$ ,  $x_{t-1,1}, \dots, x_{t-1,k}$  – lagged exogenous variables in time  $t-1$ ,  $\beta_0, \beta_j, \gamma_j$  – structural parameter of the model ( $j = 0, 1, \dots, k$ ).  $\varepsilon_t$  – error term in time  $t$  (residual).

Investment activity of farmers in Poland has been characterized by a variable whose variability is described by the following model (1):

$Y_I$  – DYNAMICS\_INV – growth rate of investment in agriculture (constant prices of 2011, previous year=100%),

Set of potential explanatory variables in the set of variables characterizing the macroeconomic factors included:

$x_1$  – DYNAMICS\_GDP – growth of gross domestic product (constant prices of 2011, previous year=100%),

$x_2$  – PRICE\_GAP – index of price relations

(„price gap”) sold agricultural products to purchased goods and services. Index of price relations („price gap”) constitutes the ratio of price index of sold agricultural products to price index of purchased goods and services. Price indices of sold agricultural products reflect changes in average weighted procurement prices and marketplace prices received by farmers. Price indices of purchased goods and services illustrate changes in retail prices of goods and services purchased for consumer, current agricultural production or investment purposes,

$x_3$  – REDISCOUNT\_RATE – rediscount rate (for end of year),

$x_4$  – UNEMPLOYMENT – registered unemployment rate (for end of year),

$x_5$  – INFLATION – inflation,

$x_6$  – AGR\_PRICE\_CHANGES – price indices of gross agricultural output (previous year=100%). Price indices of gross agricultural output expressed synthetically the changes of prices of the sold products, i.e. average procurement prices and prices received by farmers on marketplaces,

$x_7$  – AGRI\_TRADE\_BALANCE – the ratio of the trade balance of foreign trade in agri-food products to the gross domestic product,

$x_8$  – TRADE\_BALANCE – the ratio of the trade balance of foreign trade to gross domestic product,

$x_9$  – TERMS\_TRADE – *“terms of trade”* index presents the relation of price changes of exported commodities to price changes of imported commodities,

$x_{10}$  – REAL\_INCOME – index of gross disposable real income of the households sector per capita (previous year=100%),

$x_{11}$  – EXPORTS – exports (previous year = 100%),

$x_{12}$  – IMPORTS – imports (previous year = 100%),

$x_{13}$  – TOTAL\_CONSUMPTION – total consumption (previous year = 100%),

$x_{14}$  – FOOD\_CONSUMPTION – consumption of food and non-alcoholic beverages (previous year = 100%),

$x_{15}$  – ALCOHOL\_CONSUMPTION – consumption of alcoholic beverages and tobacco (previous year = 100%).

All the variables used in the analysis are in

fact the first difference of variables time series<sup>1</sup>. This approach was applied to avoid the danger of spurious regression, as the time series of all the variables (both endogenous and exogenous) are non-stationary<sup>2</sup>.

Set of explanatory variables does not cover all macroeconomic factors determining the investment activity in agriculture. The selection of explanatory variables in the model resulted from the substantive and the availability of data. The a priori selection method was used to remove insignificant variables.

## RESULTS AND DISCUSSIONS

During that research period, the rate of investment was characterized by cyclical changes. During this period, one can identify six distinctive phases of investment in agriculture in Poland:

- phase I – years 1991 – 1993,
- phase II – years 1994 – 1996,
- phase III – years 1997 – 2004,
- phase IV – years 2005 – 2008,
- phase V – years 2009 – 2010,
- phase VI – from the year 2011.

The first phase was characterized by a negative rate of changes in the level of investment. Negative rate of investment during this period in Poland was due to the deep recession transformation during the transition of the economy from a centrally planned system to a free market system. Mainly it was a period of managing existing capacity in economic entities which was supported by capital barrier, as well as the high cost of capital. In this period, high barrier to effective demand and high interest rates continued, which raised negative expectations for economic development, and

<sup>1</sup> The problem of spurious regression (or nonsense correlation) was identified for the first time by Granger and Newbold [6] They concluded that even if non-stationary time series are randomly generated, “(...) it will be the rule rather than the exception” [6, p. 117] that econometric models estimated on the basis of this time series will make the appearance of a statistically significant relationship.

<sup>2</sup> The stationarity of variables time series were tested with ADF and KPSS tests.

resulted in an increase in risk associated with the investment. In agriculture the collapse of investment during this period was also compounded by the significant deterioration in the financial situation of farms in conjunction with the radical reduction of public support for agriculture.

The second phase is a period of very rapid growth in investment. The causes of intensification of investment activities by farmers in this period can be seen in making available since 1994, a relatively large number of new preferential credits (low interest) for the agri-food sector, financed with public funds. Furthermore, in this period of time the profitability of agricultural production has improved as assessed using the ratio of the price relations („price gap”) (Figure 2). In the first phase of the investment in 1992 and 1994, the rate was beneficial to farmers, more than 100, which could result in optimistic perception of the economic situation of farmers in the future and, combined with the ability to benefit from preferential investment loans resulted in increased investment activity.

The third phase of investment in agriculture, covering the period of 1997 to 2004 was characterized by a negative rate of investment (except for 2002). It may be noted that throughout the third phase of investment in agriculture, the "price gap" indicator (Figure 2) remained at a negative level (year 2000 was the only exception), which indicates the relationship of investment activity farmers felt and the expected level of prosperity. The fourth phase of the investment is associated with the Polish accession to the European Union. In agriculture, the fact that the integration affected the intensification of investment activity and maintaining a positive rate of investment. Increase in investment activity of farmers after the integration of Poland with the structures of the European Union on the one hand was associated with the need to adapt agriculture to EU legislation, but on the other hand, it was due to changes in agricultural policy. Polish integration with the European Union allowed Polish farmers to access to funds for the development of agriculture and rural

development that were several times larger than before integration with the EU. In addition, an extensive system of support for agriculture in the European Union, and in particular the agricultural income support made it possible to reduce the risk of current operations and investment activities.

While for agriculture, the positive effect of integration with the EU came a year after the Polish accession to the European Union. In this period it also was possible to observe favorable economic trends in agriculture assessed using the "price gap" indicator which also contributed to the increased level of investments. The importance of agricultural policy in stimulating investment demand of farmers in the countries of Central and Eastern Europe after the accession to the European Union was highlighted by the following authors: Gospodarowicz M. *et al.* [5], Grzelak A. and Kiełbasa B. [7], Sasu G. [11], Wigier M. [13], Wigier M. *et al.* [14], Zawadzka D. *et al.* [15]. Public aid in the form of direct payments and investment grants may affect the investment decisions of farmers, because they are a source of additional resources, which increases the possibility of creation of own funds, and increases the investment capacity of farmers. Farmers whose capability is limited by the lack of capital, when receiving direct payments increase their credit score.

The fifth investment phase, which is characterized by a negative rate of investment, is related to the global financial crisis. However, in agriculture negative capital expenditure rate remained relatively short, only for two years. After this period, there was a sixth agricultural investment phase that is characterized by a positive rate of investment (Figure 1), which also could be related to the economic recovery.

With the help of multiple regression model (1) the macroeconomic factors affecting the rate of growth of investment in agriculture in Poland have been identified.

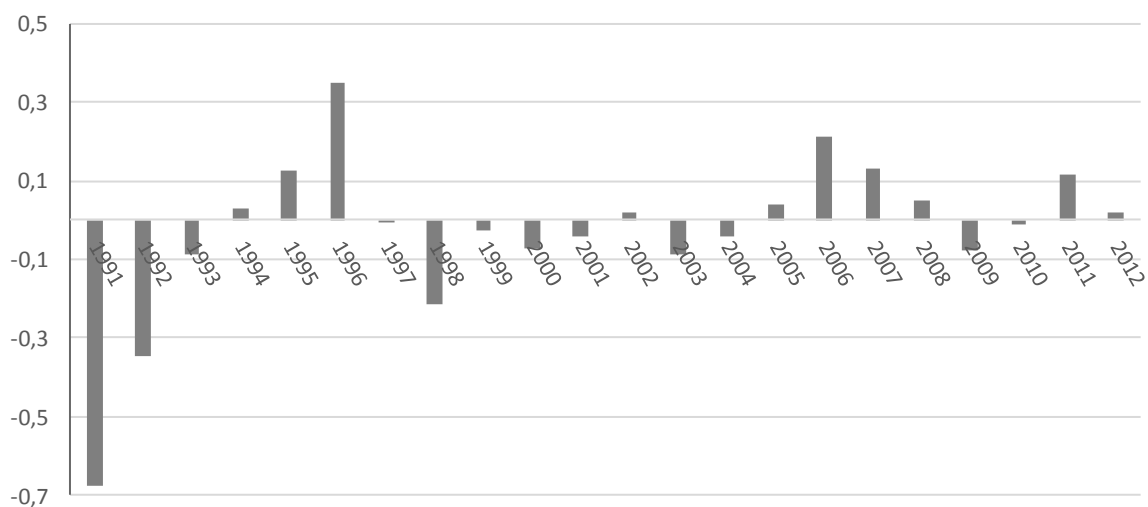

Fig. 1. The rate of investment in agriculture in the years 1991 - 2012 (previous year = 1, constant prices of 2011)  
 Source: own calculations based on statistical data of the Central Statistical Office

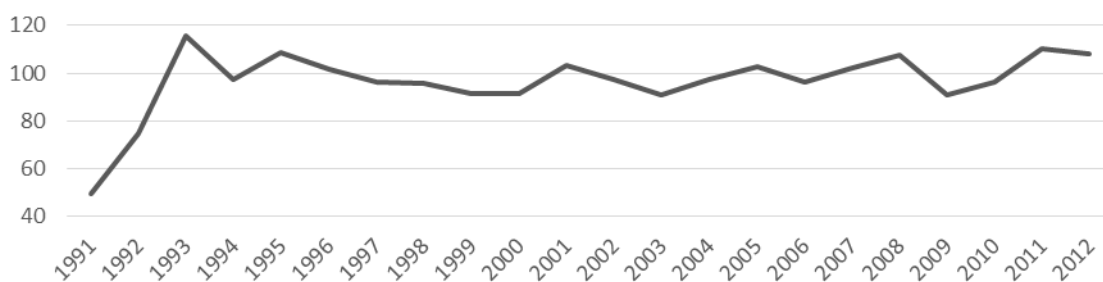

Fig. 2. Index of price relations („price gap”) sold agricultural products to purchased goods and services in years 1990 - 2012  
 Source: Central Statistical Office

The level of investment activity of farmers in the analyzed period was explained with the help of six variables (Tab. 1). With the increase of  $x_7$  - relations trade deficit in foreign trade in agri-food products to the gross domestic product,  $x_{14}$  - consumption of food and non-alcoholic beverages,  $x_{4t-1}$  - the rate of registered unemployment in the previous year,  $x_{10t-1}$  - index of gross disposable income real of the households sector per capita in previous year,  $x_{2t-1}$  - index of price relations („price gap”) the level of investment made in agriculture increased. The negative correlation was observed between the growth of investment, and  $x_9$  - „terms of trade”. The resulting model shows the positive significance of demand factors, such as increased food intake and growth of real gross disposable income of the households sector per capita in stimulating pro-investment

behavior of farmers. Both of these factors are interrelated, the increase in disposable income and increase food consumption stimulates farmers to take the trouble of investment. Despite the impact of the Engel's law, growth of real gross disposable income of the households sector affects the growth of food consumption, but also has a positive effect on the level of savings, which determine the level of ongoing investment in the economy. It also seems not insignificant that Poland is a country with a lower level of household income and because of that the demand for food has a lower income elasticity than in countries with much higher disposable income per capita. Yet, indices of gross disposable income of the real sector households per capita have impact on the dynamics of investment in agriculture with annual delay. Similarly, the growing importance of exports

of agri-food products in relation to GDP, as a factor of demand factors, has a positive effect on investment activity of farmers. Since the Polish accession to the European Union the importance of foreign trade in agri-food products has been increased. Poland is among the few countries that are net exporters of food [2]. Easier access to EU agricultural markets after the Polish accession to the EU, was very well spent by Polish farmers. However, increasing foreign trade (especially food exports) has placed high demands on the Polish agricultural sector and the agri-food industry, related to adaptation to EU standards of quality, and this required to incur significant capital expenditures. Another statically important macroeconomic factor that influences the dynamics of investment in agriculture was the *terms of trade* index that specifies the relation of changes in prices of exported commodities to changes in the prices of imported goods. However, in this case, the deterioration in the *terms of trade* have a positive impact on farmers' investment activity. This means that a faster decline in the prices of goods exported compared to the prices of imported goods had a positive effect on the level of the investments. This may result from the fact that the Polish agribusiness is based on a price competitive advantage. If price conditions worsen in foreign trade it tends to allow farmers to invest to reduce production costs and improve competitiveness through increased productivity and quality. The specified model also points to the importance of trends in agriculture characterized by the index of price

relations ("price gap"). Along with the improvement of economic situation in agriculture, profitability of agricultural production improves, the risk of management reduces and, consequently, farmers are likely to increase the involvement of investment. Yet, the impact of this indicator appears only after one year. The level of unemployment stimulate increase of investments in agriculture. With the increase in the number of unemployed the level of the investments rises. This may be related to the characteristic features of agriculture in Poland: a high level of employment in agriculture and high dispersion of the agrarian structure. In the case of social upheaval caused by economic change, a household, even a small-area, can be a source of secure income for people who have lost their jobs in non-agricultural sectors. Job loss (in nonfarm sector) by the farmer or members of his family, tends to make investments in production workshop to increase the production capacity of farms and to sustain agricultural income. Matching of designated empirical data model is 91.53%. The inspection of residuals is an important check on the appropriateness of an econometric model. The results of the residuals examining are shown in Table 5. The test listed in Table 2 checks the main properties of residuals that describe the quality of an econometric model. In all the tests used for the inspection of residuals listed in Table 2 the null hypothesis says the model has desired property.

Table 1. Regression summary of depend variables:  $Y_t$ - DYNAMICS\_INV - growth rate of investment in agriculture

Variable	bj	S(bj)	t	p value	Significance
$x_0$ - Constant	-4.09772	1.11939	-3.661	0.0023	***
$x_{4,t-1}$ - UNEMPLOYMENT	0.028737	0.00516252	5.566	5.39e-05	***
$x_7$ - AGRI_TRADE_BALANCE	2.78698	0.543387	5.129	0.0001	***
$x_{10,t-1}$ - REAL_INCOME	0.0462607	0.00662505	6.983	4.41e-06	***
$x_9$ - TERMS_TRADE	-0.0255722	0.0033519	-7.629	1.54e-06	***
$x_{2,t-1}$ - PRICE_GAP	0.00704656	0.000828816	8.502	4.04e-07	***
$x_{14}$ - FOOD_CONSUMPTION	0.0194998	0.00527857	3.694	0.0022	***

$R^2 = 0.915302$ ; corrected  $R^2 = 0.881423$

Source: own calculations based on statistical data of the Central Statistical Office



Table 2. Summary of equation residuals

Test	Test statistics	p
Breusch-Pagan heteroscedastity test	LM = 4.53377	0.8060
ARCH test	TR <sup>2</sup> = 3.41494	0.4909
RESET test	F(1, 12) = 0.188726	0.6717
LM autocorrelation test	LMF = 0.495979	0.4947
Jarque-Bera normality test	$\chi^2 = 1.2691$	0.5302
Quand likelihood test for structural brakes	QLR = 3.19	more than 0.1

Source: own study

The null hypothesis cannot be rejected in all the test. It can be assumed that the mode used for analysis properly described the changes in the agricultural investments in Polish agriculture in the period 1990-2012.

## CONCLUSIONS

Investments are necessary to support the growth and development of agriculture and the need to adapt agricultural production to the major challenges of global agriculture, notably meeting increasing demand from a growing world population, contributing to eradicating hunger and malnutrition, and preserving the natural resources upon which agriculture and we all depend. If agriculture is to meet these challenges, it requires increased investment spending.

The agricultural sector is globally exposed to strong changes in its economic environment. Farmers' investment decisions are dependent on the investment climate, which is seen through the prism of changes in the economic environment. If the economic environment, including the macroeconomic environment is conducive, farmers invest more, and the resulting benefits to both private and public are much more likely.

Based on study, it was found that among the analyzed macroeconomic factors positive effect was attributable to the demand factors such as increased food consumption, increase in the importance of exports of agri-food products in the shaping of the GDP or increase of gross real disposable income of the households sector per capita. In addition, the increase of profitability of agricultural production (assessed by the index of price relations "price gap") had a stimulating effect

on the level of investments carried out by farmers, improving their profitability compared to other investment alternatives. The developed model had no variables related to the cost of capital, such as inflation and the rediscount rate. This only confirms that the main significance is related to factors associated with consumer demand, not the factors determining the cost of capital.

## REFERENCES

- [1] Branca G., Tennigkeit T., Mann W., Lipper L., 2011, Identifying Opportunities for Climate-Smart Agriculture Investments in Africa. FAO & World Bank Final report
- [2] Chechelski P., 2009, Czynniki zewnętrzne (makroekonomiczne) wpływające na handel zagraniczny produktami rolno-spożywczymi. [w:] praca zb. pod red. R. Mroczka Wpływ instrumentów polityki handlowej Unii Europejskiej na handel zagraniczny produktami rolno-spożywczymi. Program Wieloletni 2005-2009 „Ekonomiczne i społeczne uwarunkowania rozwoju polskiej gospodarki żywnościowej po wstąpieniu Polski do Unii Europejskiej”, No. 155, IERiGŻ-PIB, Warsaw, (in Polish)
- [3] Fousekis P., Shortle J.S., 1995, Investment Demand When Economic Depreciation Is Stochastic 1995. American Journal of Agricultural Economics, Vol. 77, No. 4
- [4] Gallerani V., Gomez y Paloma S., Raggi M., Viaggi D., 2008, Investment behaviour in conventional and emerging farming systems under different policy scenarios. JRC Scientific and Technical Report Institute for Prospective Technological Studies
- [5] Gospodarowicz, M., Grochowska, R., Judzińska, A., Łopaciuk, W., Mańko, S., Oliński, M., Wasilewski, A., Wigier, M., 2013, CAP implementation in Poland-state and perspectives. Multi-Annual Program 2011-2014 „Competitiveness of the Polish food economy in the conditions of globalization and European integration”. Institute of Agricultural and Food Economics-National Research Institute, Warsaw
- [6] Granger C.J.W., Newbold P., 1974, Spurious

Regression in Econometrics, Journal of Econometrics, vol. 2: pp. 111-120

[7]Grzelak, A., Kielbasa, B., 2014, Assessment of the Use of the European Union Funds to Support Investments on Polish Farms in the Regional Perspective. Acta Scientiarum Polonorum. Oeconomia, (2), pp. 49-60

[8]Kataria, K., Curtiss, J., Balmann, A., 2012, Drivers of Agricultural Physical Capital Development. Theoretical Framework and Hypotheses. Factor Markets. Working Paper, No. 18

[9]Kusz, D., Gędek, S., Ruda, M., Zajac, S., 2014, Endogenous Determinants of Investments in Farms of Selected Countries of Central and Eastern Europe. Scientific Papers. Series „Management, Economic Engineering in Agriculture and Rural Development”, Vol. 14(3):110-119

[10]Pindyck, R.S., 1991, Irreversibility, Uncertainty, and Investment. Journal of Economic Literature, Vol. 29(3):1110-1152

[11]Sasu, G., 2011, Financial Instruments to Increase Investment in Agriculture. Scientific Papers. Series „Management, Economic Engineering in Agriculture and Rural Development”, Vol. 11(2):188-193

[12]Thijssen G., 1996, Farmers' Investment Behavior: An Empirical Assessment of Two Specifications of Expectations. American Journal of Agricultural Economics, Vol. 78(1):166-174

[13]Wigier, M., 2012, The agri-food sector in Poland-an analysis and assessment of CAP results in 2000-2011. Agroзнање, 13(4):619-631

[14]Wigier, M., Wieliczko, B., Fogarasi, J., 2014, Impact of Investment Support on Hungarian and Polish Agriculture. In 142nd Seminar, May 29-30, 2014, Budapest, Hungary (No. 172973). European Association of Agricultural Economists

[15]Zawadzka, D., Strzelecka, A., Szafraniec-Siluta, E., 2012, The assessment of European Union support for financing the investments of agricultural holdings in Poland. 6th International Scientific Conference Managing and Modelling of Financial Risks, VŠB-TU Ostrava, Faculty of Economics, Finance Department, Ostrava, pp. 673-683

[16]Žídková, D., Rezbová, H., Rosochatecká, E., 2011, Analysis of Development of Investments in the Agricultural Sector of the Czech Republic. Agris on-line Papers in Economics and Informatics. Volume III. No. 1, pp. 33-43

## CHANGES IN THE RELATIONS OF PRODUCTION FACTORS IN AGRICULTURE (THE CASE OF POLAND)

**Dariusz KUSZ**

Rzeszow University of Technology, Faculty of Management, Rzeszów al. Powstańców Warszawy 10, 35-959 Rzeszów, Poland, Phone: +48 17 865 11 20, Fax: + 48 17 862 81 93, E-mail: dkusz@prz.edu.pl

*Corresponding author:* dkusz@prz.edu.pl

### *Abstract*

*Observed trends in the changes in relations between the production factors and the level of price of agricultural products cause in the long term the necessity to adopt new production technologies. In the situation of fast growth of the labour cost in relation to other production costs there is necessity to adopt labor-saving technology in order to improve the capital – labour relation. It results in substitution of more expensive labour by less expensive capital. The aim of this study is to analyze the changes in relation of production factors in agriculture on the example of Poland. It has been stated that in agriculture in Poland, the loss of land used for agriculture and decapitalization of fixed assets in the absence of outflow of the agricultural population to non-agricultural departments are observed. The result is a deterioration in the relationship between labor resources and the resources of land and capital.*

*Key words:* capital, efficiency of production factors, labor, land, relationships between factors of production

### INTRODUCTION

The organization of production processes in agriculture is based on the appropriate binding together the individual factors of production (land, labor and capital). The connection method of production factors in certain production processes is defined as technique of production. Each farmer in the manufacture of products has to choose the appropriate manufacturing techniques. Mutual relations of production factors depend mainly on the relative prices of factors of production and performance. Behaving rationally manufacturer tries to always use the factors of production to a greater extent that are relatively cheaper (compared with their productivity), and reduce the consumption of these, which are expensive. Factors of production can replace each other, so they are substitutable provided that there is a certain (often very large number of production techniques). If there is only one production techniques, substitution of production factors is impossible [7]. In a market economy the correct allocation of factors of production (in terms of their relationship and their level) is the basis for effective management.

Analysis of the world's agricultural diversity indicates the existence of some general regularities, based on which the proportions of the factors of production are arranged, determining the level and structure of agricultural production costs. In each country there are in a particular historical moment some resources of production factors, which determine their supply and prices. This in turn affects the way the management of enterprises by the choice of the optimal production techniques. Pricing system makes the combination of factors of production in each country and in all circumstances different. With the abundance of land and scarcity of capital ratio of cost of land to capital is that it pays off to combine large areas of land with a relatively small amount of capital. Production remains at low levels of capital intensity. But where there is a large abundance of technical resources (capital), their price is relatively low. Because of that, the share of capital in the production process will be greater [5, 9]. In the case of agriculture, there are two important types of relationships: (i) between labor and capital inputs and land resources; (ii) between the resources of land and capital and labor resources. The first type of

relationship is used to measure the so-called the intensity of agricultural production. The second type of relationship is in turn the meter of equipping labor with land and other production means, particularly technical.

The aim of this study is to analyze the changes in relation of production factors in agriculture on the example of Poland.

## MATERIALS AND METHODS

The empirical material were statistical data from the Central Statistical Office of Poland for the years 1995 - 2013, and data from the European Farm Accountancy Data Network (FADN) for the years 2004-2012.

The paper presents the basic relationship between the three factors of production: land, labor and capital. Changes in the efficiency of production factors of production resources involved were shown against the background of these relations. Gross agricultural output<sup>3</sup>, intermediate consumption<sup>4</sup>, gross value of fixed assets, net value of fixed assets were expressed in constant prices of 2011, making adjustments based on inflation.

## RESULTS AND DISCUSSIONS

The management of the production potential in agriculture is based on existing opportunities for combination of and substitution of factors of production. The phenomenon of substitution of factors of production creates many possibilities of their combination, depending on the socio-economic and technical nature. Particularly important for the relationship of factors of

production are their prices, especially rising labor costs compared to other factors of production [8]. In conditions of rapid growth in labor costs compared to other factors of production it becomes necessary to implement labor-saving technology resulting in an increase in the capital-labor relations. The result is a substitution of increasingly expensive inputs of labor by relatively cheaper capital. However, the problem of substitution of factors of production in agriculture is complicated. In this case, substitution of production factors is loaded by the factor of the land. Agricultural production is described by the three-factor production function, rather than the two-factor as in other fields. Hence the efficiency and cost of materials is limited by the efficiency of the factor of the land. Land as a factor of production is characterized by a lack of mobility, which among other things implies inefficient, by Pareto, allocation of production factors. In addition, land factor due to natural reasons has a naturally limited opportunity to stimulate productivity.

Production potential of agriculture depends on the level of equipping with the factors of production. Land resources in Poland in the analyzed period decreased from 17.9 million hectares to 14.6 million hectares, an change of 18.5% (Figure 1). The decline in the agricultural area is an inevitable process, resulting from an increase in the competitiveness of land use between both agricultural and non-agricultural use as. Agricultural and economic analysis on the countries of medium and highly developed market economy indicate the prevalence of these trends. The high rate of loss of agricultural land means a new economy of land resource utilization. The consequence of this is the new shape of the production processes in agriculture, which is to increase the intensification of effort per unit area of agricultural land, with all the consequences, such as negative externalities, including environmental. This process can be observed in agriculture in Poland, the decrease in the area of agricultural land has increased the production intensity reflected in an increase in the intermediate consumption per unit of

---

<sup>3</sup> Gross agricultural output includes: crop output, i.e., raw (not processed) products of plant origin (harvests for a given year); animal output, i.e., production of animals for slaughter, raw (not processed) products of animal origin as well as the increase in farm animal stocks (livestock - the basic and working herd) which include: cattle, pigs, sheep, horses and poultry.

<sup>4</sup> Intermediate consumption includes the value of agricultural products from own production, agricultural products utilised for production purposes as well as the purchase of materials (including fuels), energy, outside services (external processing, agricultural, veterinary, insemination and transport services, current repairs, telecommunications services, commissions paid for banking services), financial intermediation services indirectly measured (FISIM), costs of business travels (excluding data regarding private farms) and other costs (e.g. insurance, rentals and leasing). The valuation of materials used in production was performed using annual average purchase prices.

utilized agricultural area (Figure 9).

Economic development of any country is associated with changes in the level and structure of employment. Reaction of agriculture to economic development is facilitated by structural changes (especially the concentration processes occurring in agriculture) and the outflow of the agricultural population to non-agricultural sectors. Analyzing the labor force in agriculture in Poland, we can see that despite the economic development of the country there has not been a significant outflow of population employed in agriculture to non-agricultural departments, and even since the year 2010 the number of people employed in agriculture has increased

(Figure 1). Relationship of the number of people working in agriculture per 100 ha (Figure 2) and the percentage of people working in agriculture in total employment (in the years 2005 to 2013, this ratio at the level of 16-17%) also remained at a high level. This situation may be related to the inability to move away from agriculture resulting from high unemployment persisting in the national economy (Figure 3). In addition, it may be due to the nature of farms in Poland, where family farms, spatially small, with excess of labor are predominant.

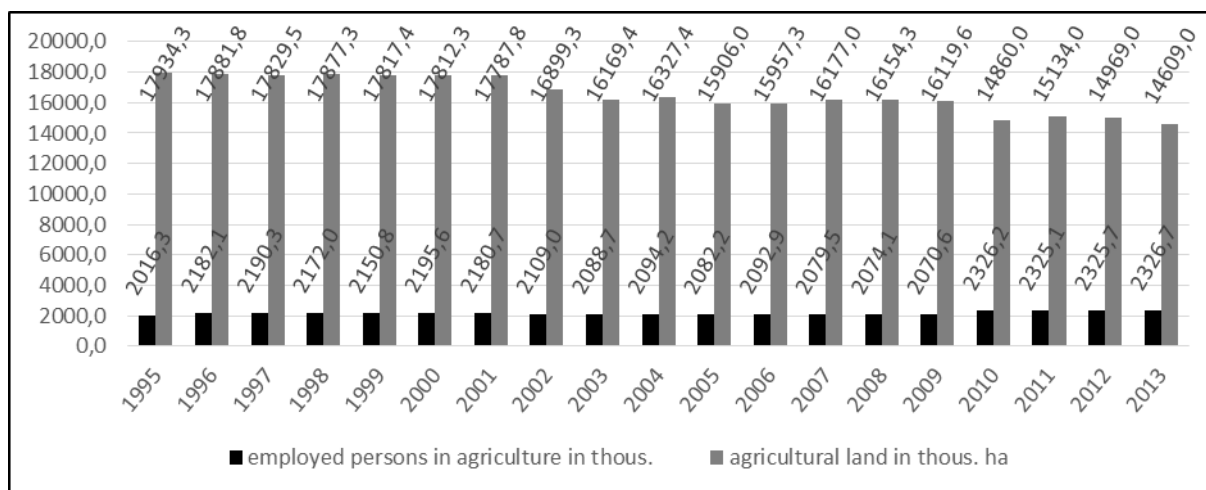

Fig. 1. The number of people employed in agriculture and the agricultural area in Poland in the years 1995-2013  
 Source: own calculations based on statistical data of the Central Statistical Office

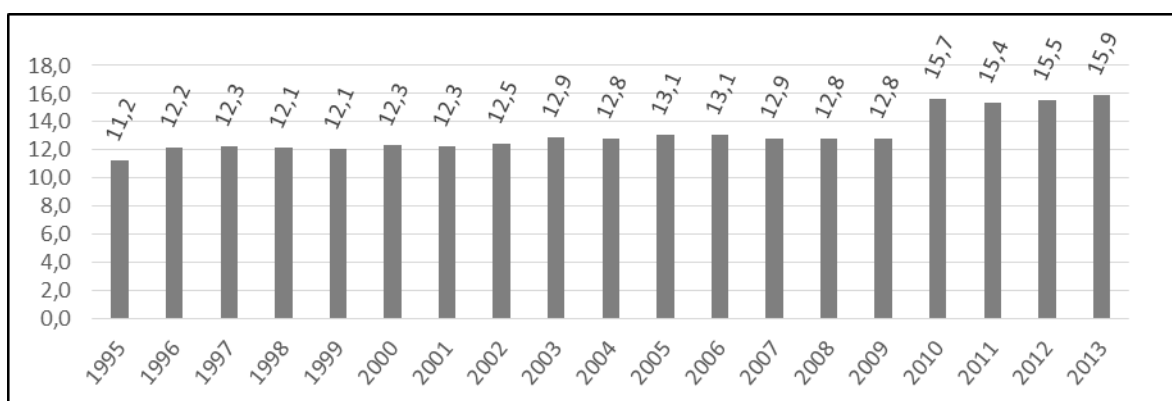

Fig. 2. Number of persons engaged in agriculture per 100 ha of agricultural land in Poland in the years 1995-2013  
 Source: own calculations based on statistical data of the Central Statistical Office

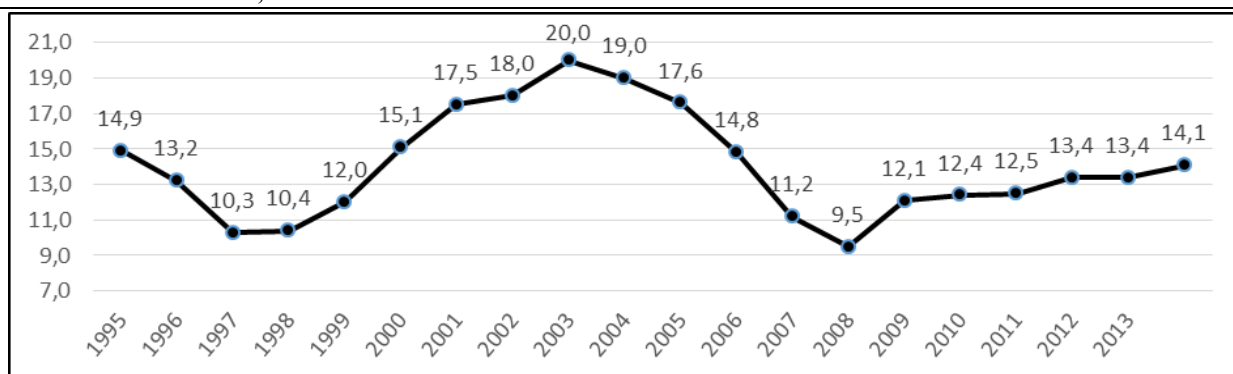

Fig. 3. The unemployment rate in Poland in the years 1995-2013 [%]

Source: own calculations based on statistical data of the Central Statistical Office

The level of agricultural equipment in fixed assets determines the degree of agriculture technisation. The real value of the gross and net assets in agriculture in Poland in the analyzed period of time was reduced (Figure 4). Similarly, the value of fixed assets per employee and per 1 ha of agricultural land decreased. However, in 2013 this trend was halted and technical equipping of land and work has increased compared to 2012 (Figure 5 - 8). Cited statistics include all farms in Poland, but do not show the state of differentiation of Polish agriculture. Generally it is manifested in the existence of many small, vulnerable households having a social character, with marginal contacts with the market and the relatively small number of larger farms producing for the market (Table 1). In small farms, representing the vast majority there is a lack of investment capacity and the process of depreciation of fixed asset is present. Investment capabilities are held by greater farms with potential for development. The changes that occur in the group of commodities farms can be observed by analyzing the data obtained from the Polish FADN (Farm Accountancy Data Network). The observed relationship between the factors of production tend to be different than those observed in agriculture in Poland. Labor input per unit area of agricultural land decreased, and labor resources and land equipment in total assets and fixed assets increased (Table 2). While analyzing the relationship of selected non-current assets (buildings and machinery) to the land resources and effort, the ratio of machines than buildings increased to a greater extent (Table 2). This situation

indicates that changes in the structure of fixed assets in the advantage of mobile assets over nonmobile. Investments in mobile assets, compared to non-mobile fixed assets, are characterized by a greater degree of reversibility due to the higher degree of liquidity of these assets and a market for used machines [3]. Therefore, the flexibility of agricultural holdings increased. It is worth to pay attention to a relationship, despite the decline in the value of the gross and net assets per 1 ha of agricultural land, the level of intermediate consumption increased (expenditure of current assets, such as: yield-forming agents, fertilizers, pesticides) on agricultural area (Figure 9). It is related to the need to implement technical progress in agriculture [6], especially biological, but also is related to the availability of technical and biological agents not only in a substantive sense, but also because of their price decrease [7]. The need to implement biological and chemical technology is also associated with the loss of agricultural land in Poland and the desire to increase the productivity of the land. The observed trend of increasing expenditures related to the current assets while reducing fixed assets may also be associated with a desire to improve the structure of capital employed in curbing capital assets (generating fixed costs, which is characterized by a lack of mobility, irreversibility or less flexibility) in favor of the current assets. Furthermore, it can also be a reflection of the structural changes in agriculture in Poland, consisting of a slow decrease in the share of smallest-area households (Table 1).

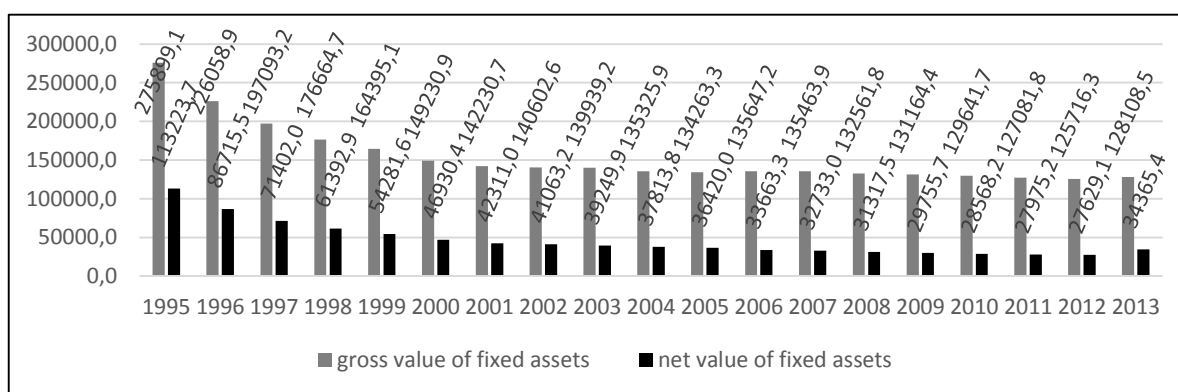

Fig. 4. The gross and net value of the assets in agriculture in Poland in the years 1995-2013 [million PLN] - fixed prices in 2011

Source: own calculations based on statistical data of the Central Statistical Office

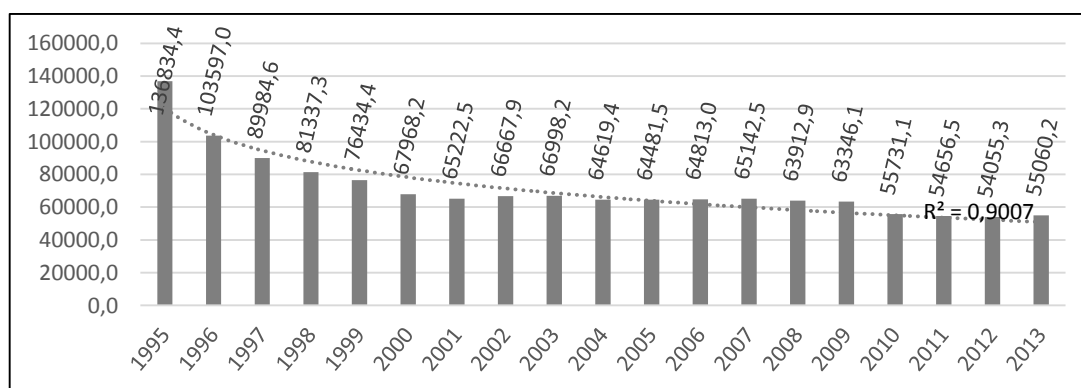

Fig. 5. The gross value of fixed assets per worker in agriculture in Poland in the years 1995-2013 [PLN] - fixed prices in 2011

Source: own calculations based on statistical data of the Central Statistical Office

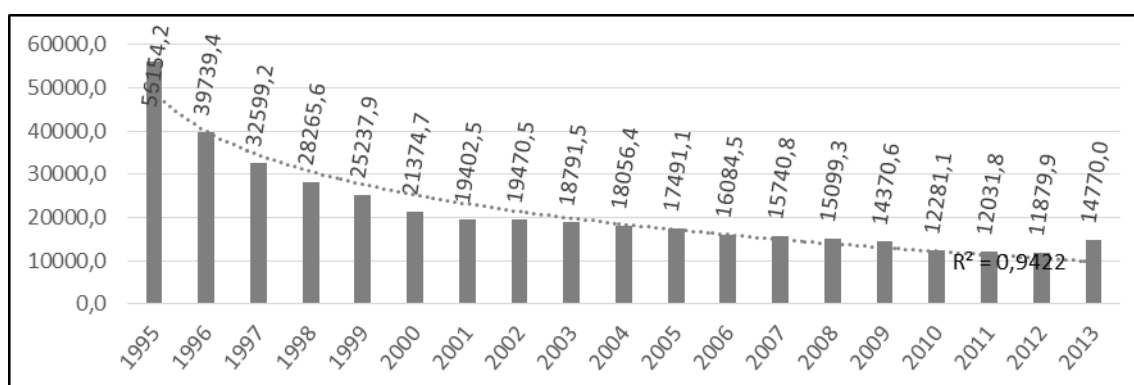

Fig. 6. The net value of fixed assets per worker in agriculture in Poland in the years 1995-2013 [PLN] - fixed prices in 2011

Source: own calculations based on statistical data of the Central Statistical Office

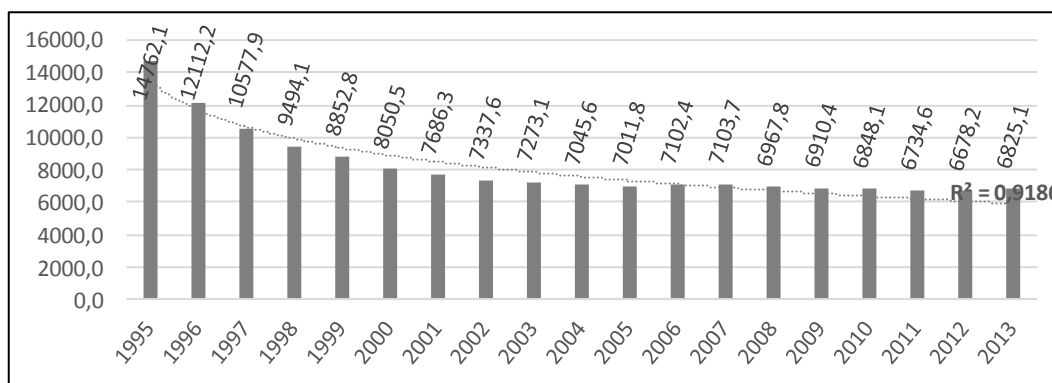

Fig. 7. The gross value of fixed assets per 1 ha AL in agriculture in Poland in the years 1995-2013 [PLN/1 ha AL] - fixed prices in 2011

Source: own calculations based on statistical data of the Central Statistical Office

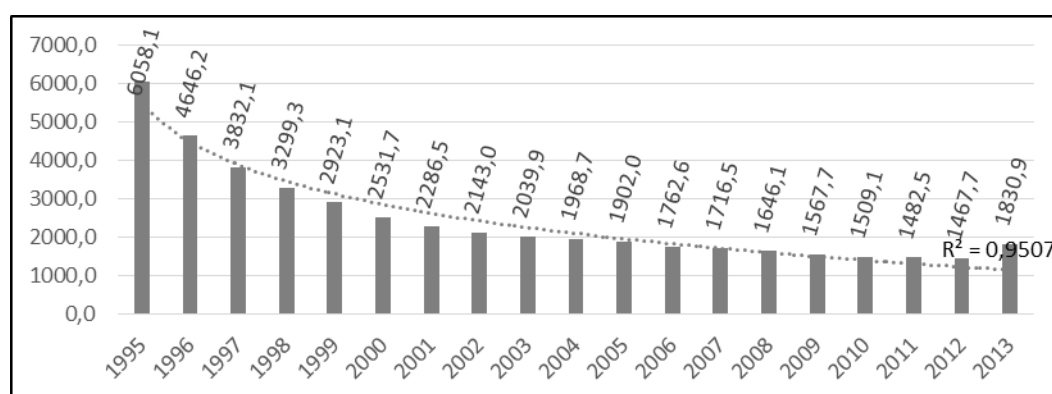

Fig. 8. The net value of fixed assets per 1 ha AL in agriculture in Poland in the years 1995-2013 [PLN/1 ha AL] - fixed prices in 2011

Source: own calculations based on statistical data of the Central Statistical Office

Table 1. Number of farms of the area exceeding 1 ha in Poland in the period 2002-2013 (in thousands)

Year	Total	Farm size clusters			
		1-5	5-20	20-50	>50
2002	Number 1,951.7	1,146.3	692.8	95.5	17.1
	% 100	58.7	35.5	4.9	0.9
2010	Number 1,480.2	790.0	569.4	96.6	24.3
	% 100	53.37	38.47	6.53	1.64
2013	Number 1,391.1	732.5	526.3	102.9	29.3
	% 100	52.66	37.83	7.40	2.11

Source: own calculations based on statistical data of the Central Statistical Office

Table 2. Relations of production factors in farms engaged in agricultural accounting according to the rules of the FADN

Parameter	Year								
	2004	2005	2006	2007	2008	2009	2010	2011	2012
Total labor input AWU*/100 ha AL	11.19	10.31	10.09	9.60	9.12	9.23	9.09	9.23	9.18
Total assets EUR/1 ha AL	4325.75	4073.33	4298.15	4861.65	5296.74	7281.92	7901.35	8048.26	8292.78
Total assets EUR/total labor AWU*	38661.36	39513.56	42588.57	50632.95	58056.98	78901.76	86914.88	87173.84	90309.83
Total fixed EUR/1 ha AL	3674.19	3428.31	3565.40	4017.89	4377.68	6518.57	7003.63	7061.08	7246.55
Total fixed EUR/total labor AWU*	32838.07	33256.50	35328.00	41845.45	47983.24	70630.59	77039.88	76481.40	78916.18
Buildings EUR/1 ha AL	1681.25	1713.16	1722.84	1812.22	1957.75	1681.43	1783.06	1770.21	1786.52
Buildings EUR/total labor AWU*	15026.14	16618.64	17070.86	18873.86	21458.66	18218.82	19613.69	19173.84	19455.49
Machinery EUR/1 ha AL	991.99	969.89	975.09	1054.94	1209.33	1066.99	1106.33	1151.74	1206.21
Machinery EUR/total labor AWU*	8865.91	9408.47	9661.71	10986.93	13255.31	11561.18	12169.64	12475.00	13135.84

\* AWU – annual work unit – full time person equivalent

Source: own calculations based on statistical data FADN

[http://ec.europa.eu/agriculture/rica/database/database\\_en.cfm](http://ec.europa.eu/agriculture/rica/database/database_en.cfm)



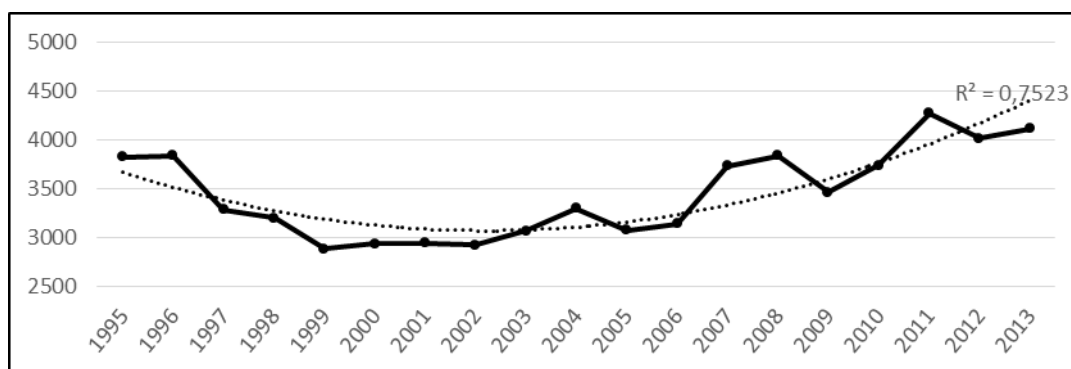

Fig. 9. The intensity of agricultural production - the value of intermediate consumption per 1 ha AL [PLN/ha] - fixed prices in 2011

Source: own calculations based on statistical data of the Central Statistical Office

Attention should be paid to the differences observed in the mutual relations of production factors between agricultural holdings under Polish FADN and the total of farms. They result from structural defects of agriculture in Poland, particularly related to high agrarian dispersion. As a result, it is difficult to achieve proper relations of production factors. The pace of concentration in agriculture influences the ability to improve the relations between labor and capital expenses and land resources and between resources of land and capital and labor resources. Activation of this

process requires a selection of appropriate instruments in support of concentration in agriculture, particularly the possibility of increasing off-farm employment. However, this depends on the level of economic development of the country, especially the absorbency of the labor market.

Changes in the relationship between the factors of production should also be considered in the context of changes in the effectiveness of individual factors of production.

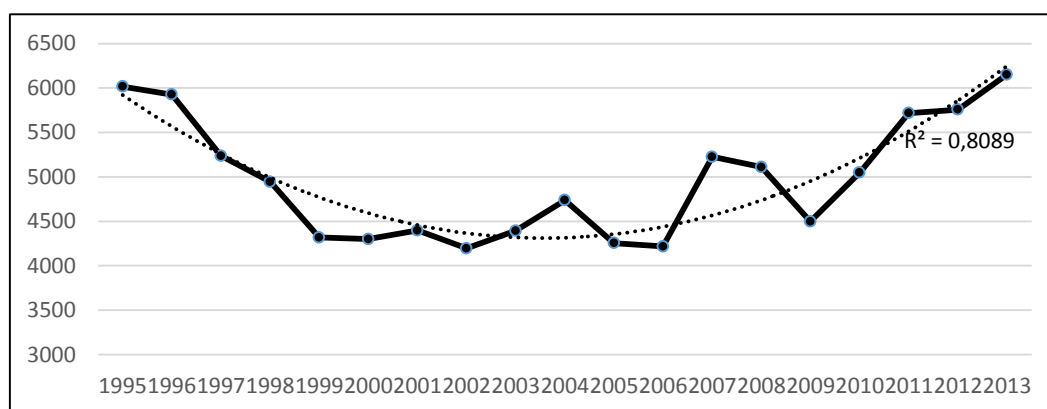

Fig. 10. Productivity of land in Poland [gross agricultural output minus payments PLN/1 ha AL] - fixed prices in 2011

Source: own calculations based on statistical data of the Central Statistical Office

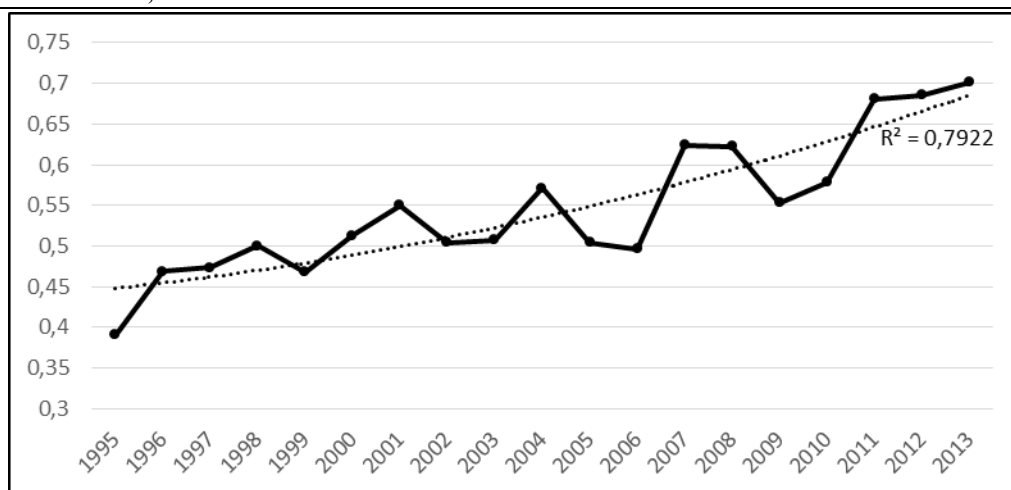

Fig. 11. Productivity of gross value of fixed assets in Poland [gross agricultural output minus payments PLN/gross value of fixed assets PLN] - fixed prices in 2011

Source: own calculations based on statistical data of the Central Statistical Office

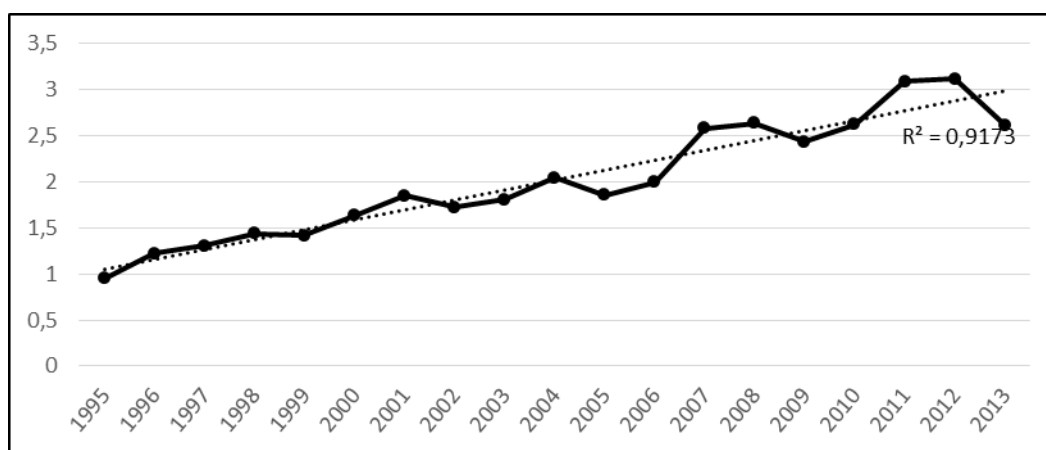

Fig. 12. Productivity of net value of fixed assets PLN in Poland [gross agricultural output minus payments PLN/ net value of fixed assets PLN] - fixed prices in 2011

Source: own calculations based on statistical data of the Central Statistical Office

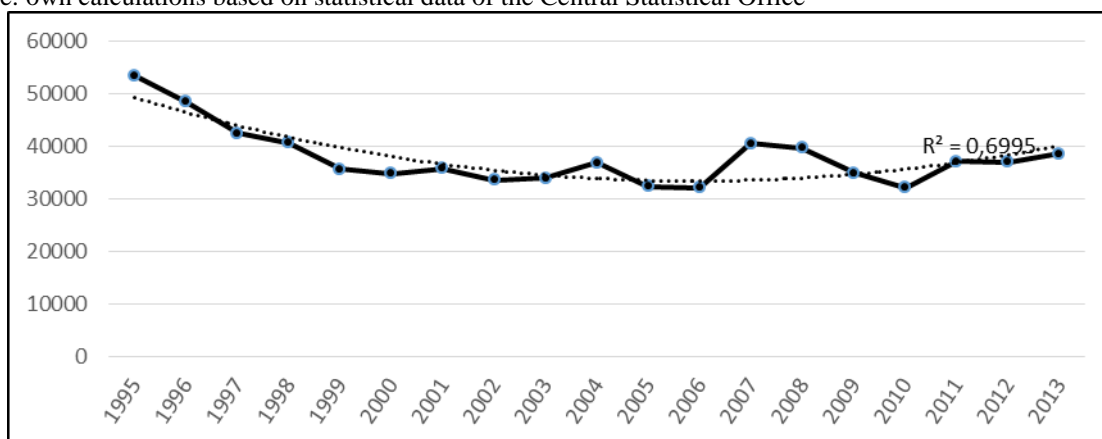

Fig.13. Labor productivity in agriculture in Poland [gross agricultural output minus payments PLN/per one employee] - fixed prices in 2011

Source: own calculations based on statistical data of the Central Statistical Office

In Poland, as presented above, the loss of the land used for agriculture occurs and the value of the assets at the disposal of the farmers was reduced, and in the case of the labor force

decline was not observed. Gross agricultural output minus the amount of payments made under direct payments schemes was used to assess the effectiveness of the factors of

production. The analysis shows that increased land productivity (Figure 10) and the effective use of gross fixed capital formation (Figure 11) and net fixed capital formation (Figure 12). In the case of labor since the Polish accession to the European Union in 2004, there has been a downward trend, after the accession, this trend has been slightly reversed (Figure 13). However, to improve the work efficiency, issues related to the possibility of migration from agriculture will be the most important. In broad terms, the mechanism of loss of employed in agriculture is described by the model of D.W. Jorgenson [2] and A.C. Kelly, J.G. Williamson and R.J. Cheetham [4]. Better known is the theory of mechanism of loss of employment in agriculture based on "labor push - labor pull." Pushing the labor force from agriculture occurs due to improvements in agricultural technology combined with Engel's law release resources from agriculture ("labor push"), and improvements in industrial technology attract labor out of agriculture ("labor pull") [1].

## CONCLUSIONS

The relationship between the factors of production affect the effectiveness of the factors of production on the one hand, on the other hand indicate the directions of changes in agriculture. The study allows us to formulate the following conclusions:

-In agriculture in Poland, the loss of land used for agriculture and decapitalization of fixed assets in the absence of outflow of the agricultural population to non-agricultural departments are observed. The result is a deterioration in the relationship between labor resources and the resources of land and capital. To improve these relationships, it is important to stimulate agrarian changes in agriculture especially concentration processes, the implementation of technical progress resulting in pushing labor from agriculture. At the same time forces must also act to allow to pull labor from agriculture, and these are mainly related to the country's economic development, especially the development of the labor market in non-agricultural sectors.

-Comparing the relationship of factors of production in agriculture in Poland to the same relationship in farms covered by FADN accounting difference in relationships is noticeable. The farms covered by Polish FADN positive changes are observed. The reason for such differences is the polarization of farms in Poland. There is a large group of small farms, economically weak and relatively small group of farms that are larger, economically stronger, investing, modernizing its production workshop.

-Changes in the relations of production factors cause changes in the efficiency of individual stocks. The research shows that productivity of land and the performance of fixed assets in agriculture increased. For labor efficiency a downward trend was mitigated.

## REFERENCES

- [1] Alvarez-Cuadrado, F., Poschke, M., 2011, Structural change out of agriculture: Labor push versus labor pull. *American Economic Journal: Macroeconomics*, 127-158.
- [2] Jorgenson, D.W., 1961, The Development of a Dual Economy. *Economic Journal*, Vol. 71, 309-334.
- [3] Kataria, K., Curtiss, J., Balmann, A., 2012, Drivers of Agricultural Physical Capital Development. Theoretical Framework and Hypotheses. *Factor Markets. Working Paper*, No. 18.
- [4] Kelley, A.C., Williamson, J.G., Cheetham, R.J., 1972, *Dualistic Economics Development: Theory and History*. University of Chicago Press, Chicago.
- [5] Klepacki, B., Żak, A., 2013, Agrarian transformations in the territory of Poland before and after integration into the European Union. *Journal of Agribusiness and Rural Development*, No. 4 (30), 95-113.
- [6] Kusz, D., 2014, Modernization of Agriculture vs Sustainable Agriculture *Scientific Papers. Series "Management, Economic Engineering in Agriculture and Rural Development"*, Vol. 14 Issue 1, 171-178.
- [7] Rembisz, W., 2008, *Mikro- i makroekonomiczne podstawy równowagi wzrostu w sektorze rolno-spożywczym*. Vizja PRESS&IT, Warsaw (in Polish).
- [8] Runowski, H., Ziętara, W., 2011, Future role of agriculture in multifunctional development of rural areas. *APSTRACT: Applied Studies in Agribusiness and Commerce*, Vol. 5, Numbers 1 – 2, 29-38.
- [9] Yamaoka, R., 1969, The "modernisation" of agriculture at the present stage. *The Kyoto University Economic Review*, No. 39(1), 1-21.



## TRENDS OF WINE MARKET IN ROMANIA: COMPETITIVENESS AND DEVELOPMENT OPPORTUNITIES IN THE CONTEXT OF MARKETS GLOBALIZATION

Georgiana-Raluca LĂDARU<sup>1</sup>, Silviu BECIU<sup>2</sup>

<sup>1</sup>The Bucharest University of Economic Studies, 6, Romana Square, Bucharest, Romania, Email: ralucaladaru@eam.ase.ro

<sup>2</sup>University of Agricultural Sciences and Veterinary Medicine, Bucharest, 59 Marasti, District 1, 011464, Bucharest, Romania, E-mail: beciu\_silviu@yahoo.com

*Corresponding author:* beciu\_silviu@yahoo.com

### Abstract

*The paper aimed to evaluate the wine market in Romania and make assumptions about its development opportunities in the context of market globalization. The paper underline directions of development related with the entrepreneurial sector. The research method is based on calculation and interpretation of competitiveness indicators. Even if the results indicated a low competitiveness of this sector, the development opportunities of wine market in Romania can lead to an increased share of this market at national level and higher level of export in terms of value on European Union and world markets.*

**Key words:** development opportunities, globalization, Romania, wine market

### INTRODUCTION

Globalization of wine markets is indicated by the increase in the share of wine world production of wine exports. Recent studies [5] regarding the trends of wine markets indicate a positive evolution of world wine trade, based rather on growing price, than increase of volume. A map of New World wine countries include Canada and USA from North America, Chile and Argentina from South America, China, India, Japan and Thailand from Asia, Australia, New Zealand and South Africa. These countries that are considered to be free of the burden of history and liberated from geographic boundaries [6] started to dominate the world wine market in terms of wine consumption (USA was the primary internal market in the world in 2013 in terms of volume consumption) and started to compete Europe in terms of wine production and trade. Romania, which is one of major wine producers in The European Union in terms of cultivated surfaces [2] had developed the National Program Support for 2014-2018 in the wine sector which propose a higher financial allocation for the wine sector. Up to 47.7 million euros annually are

distributed on 5 support measures: promotion on third-country markets; restructuring and conversion of vineyards; harvest insurance, investment in enterprise and use of concentrated grape must for enrichment [3]. Development of Romanian wine market is related with aspects such: increasing efficiency and effectiveness of supply chain, development of new segment of this market, based on market research, implementing mechanization processes and innovation at farm level. Romanian producers have to identify new opportunities on the market, being faced with a strong competition with the large diversity of imported wines. As the small and medium sized enterprises are the engines of any economy sector, is important to mention the main business environment opportunities identified in Romania [4]: increased sales on internal market, assimilation of new products, penetrating on new markets, realization of business partnership, use of new technology, obtaining a grant and increase of exports. As in any other sector in relation with agriculture and rural areas, the European funds can be an opportunity in this sector even if assuring co-financing can be an obstacle [1].

**MATERIALS AND METHODS**

For this paper, we made an assessment of evolution and opportunities of Romanian wine market in the context of world wine markets, based on national and international statistic data. In order to estimate the competitiveness of wine sector we calculated RXA – the relative export advantage index, RMA – the relative import advantage index and RTA – the relative trade advantage index.[7]

$$RXA_{ict} = (X_{ict}/X_{iwt})/(XT_{ct}/XT_{wt}), \text{ where:}$$

RXA<sub>ict</sub> – the relative export advantage index for industry i, country c in period t;

X<sub>ict</sub> – the export value of industry i, country c in period t;

X<sub>iwt</sub> – the export value of industry i in the world in period t

XT<sub>ct</sub> – the total export value of all industries of country c in period t

XT<sub>wt</sub> – the total export value of all industries in the world in period t

$$RMA_{ict} = (M_{ict}/M_{iwt})/(MT_{ct}/MT_{wt})$$

RMA<sub>ict</sub> – the relative import advantage index for industry i, country c in period t;

M<sub>ict</sub> – the import value of industry, country in period t;

M<sub>iwt</sub> – the e import value of industry i in the world in period t

MT<sub>ct</sub> – the total import value of all industries of country c in period t

MT<sub>wt</sub> – the total import value of all industries in the world in period t

$$RTA_{ict} = RXA_{ict} - RMA_{ict}$$

**RESULTS AND DISCUSSIONS**

The opportunities of development of Romanian wine market should be approached within its four dimensions: *economic dimension, contextual dimension, psychological dimension and prospective dimension*. The *economic dimension* is related with the profitability of the sector. While the surfaces under vines in Romania remained about 180,000 ha in the last years, the wine production varied from 3,287 thousands hectoliter in 2010 to 5,113 thousands hectoliter in 2013. The wine production is depending on the weather conditions which generates profits or losses at farm level and

also affect the processing sector. *The contextual dimension* is related with the existing trend on the market. The consumption of wine in Romania is relatively high, Romanian being in the tenth position at world level with more than 25 l of wine consumption per capita. In the context of increasing consumption of wine sold on market, we also estimate a reduction trend of the quantities of wine consumed from own production, which will be a benefit for the internal market. As regarding the trade, as a major event we can notice that in 2014 the wine produced in Republic of Moldavia, started to be commercialized free of duties on European Union market, with led to an increased competition for the Romanian producers. *The psychological dimension*, in the case of Romanian wine market is related with the capacity of entrepreneurs on the market to adapt to the new conditions and challenges, and to take advantage of the supporting programs available for them, which can bring them competitive advantages. *The prospective dimension* means in the case of wine market to take decisions based on market researches and related with the recent evolution or estimated trends on this market.

Table 1. Evolution of Romanian total trade and wine trade in the period 2001-2013 (USD Thousands )

Year	Total exports	Total imports	Wine exports	Wine imports
2001	1,1384,994	15,551,616	19,673	1,337
2002	13,875,709	17,861,681	23,042	1,755
2003	17,618,059	24,003,123	24,743	2,271
2004	23,485,343	32,663,696	26,240	4,189
2005	27,729,597	40,462,894	22,298	9,218
2006	32,336,030	51,106,039	22,592	36,808
2007	40,264,716	69,946,195	21,897	39,838
2008	49,538,878	82,964,979	53,524	90,275
2009	40,620,890	54,256,269	19,099	20,648
2010	49,413,386	62,006,624	17,138	27,652
2011	62,692,001	76,365,285	19,973	69,480
2012	57,904,330	70,259,719	20,529	53,964
2013	65,881,442	73,452,192	21,988	50,502

Source: International Trade Center, 2014

The competitiveness of the Romanian wine market was determined through competitive

advantage index. First we selected dates regarding Romanian total trade and Romanian trade with wine during the period 2001-2013 (Table 1), expressed in value terms. The highest value for wine exports of Romania was recorded in 2008, when was also recorded the highest value of for wine imports, which can be related with the integration of Romania in The European Union.

Table 2. Evolution of World total trade and wine trade in the period 2001-2013 (USD Thousands)

Year	Total exports	Total imports	Wine exports	Wine imports
2001	6,107,379,428	6,300,219,418	12,900,034	13,267,235
2002	6,404,193,704	6,583,363,835	14,373,474	15,529,288
2003	7,463,343,765	7,678,356,208	1,7531,033	18,488,773
2004	9,097,787,857	9,377,673,605	19,927,350	21,138,451
2005	10,366,215,624	10,610,548,233	20,704,020	22,368,027
2006	11,985,054,143	122,393,66,140	22,583,155	24,067,695
2007	13,823,120,822	14,090,086,666	27,530,806	28,831,308
2008	15,971,872,932	163,27,838,997	29,901,773	31,121,309
2009	12,310,033,186	12,584,107,194	25,553,224	26,913,614
2010	15,050,924,286	15,286,355,731	27,922,417	28,837,757
2011	18,055,465,164	18,270,543,693	32,850,031	33,873,972
2012	18,003,055,012	18,274,654,379	33,095,673	33,519,109
2013	17,974,395,141	18,702,567,695	34,551,231	35,550,771

Source: International Trade Center, 2014

We calculated the Relative Export Advantage Index, and the results are indicating a negative trend of this one, in the period 2001-2013, excepting the year 2008 (Fig.1)

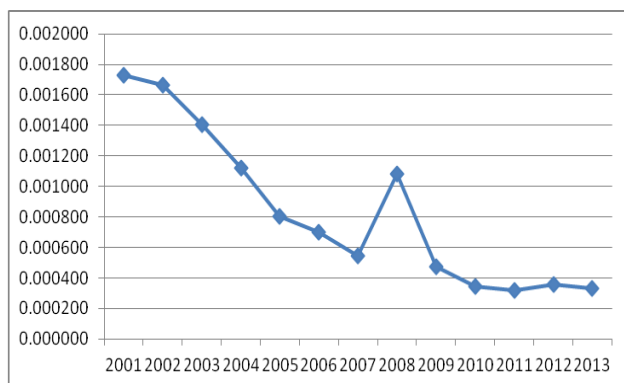

Fig.1. Evolution of RXA for wine in Romania between 2001 and 2013

The values for RMA indicated alternative trends between 2001 and 2013 (Fig.2)

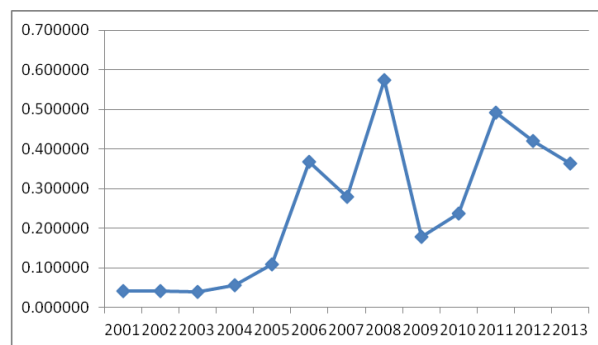

Fig.2. Evolution of RMA for wine in Romania between 2001 and 2013

Between 2001 and 2013 the RTA recorded only negative values. The lowest value was recorded in 2008.

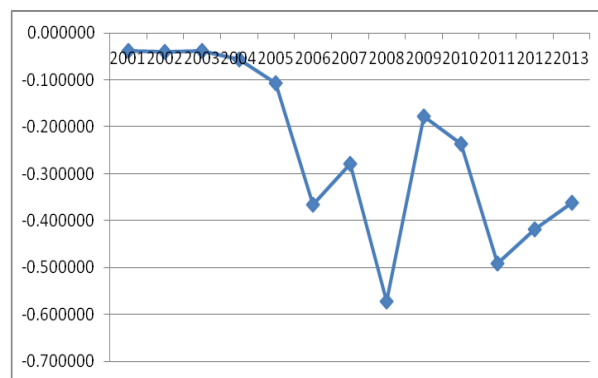

Fig.3. Evolution of RTA for wine in Romania between 2001 and 2013

One of the opportunities indicated for the development of this sector, the increased sales of Romanian wine on the market can be made through a better promotion of the Romanian products, an increased quality of these products and therefore a better quality-price ratio. Assimilation of new products is a solution for the enterprises with a history on the market that can promote new varieties on the wine market. Penetrating on new market and increasing exports are solution for the enterprises that export on the world market which can identify and promote their products on emerging wine markets. Business partnership ca be made on the entire wine chain or in relation with international enterprises specialized in wine trade. Use of new technology is a priority for the enterprises which assume the principle that innovation drives the wine industry.

## CONCLUSIONS

The level of RXA was well below 1 which means that Romania is relatively unspecialized in the wine exports. The value of RMA was below 1 during this period, but the interpretation of this index is inverted from that of RXA, which means that Romania imports relatively less comparative with the world average wine imports. The results for RTA were below zero which confirms competitive disadvantages of Romanian wine sector in relation with the World wine market. Increasing of Romanian wine sector competitiveness can be made through measures that capitalize market opportunities for the wine specialized enterprises.

## ACKNOWLEDGMENTS

This work was cofinanced from the European Social Fund through Sectoral Operational Programme Human Resources Development 2007-2013, project number POSDRU/159 /1.5/S/134197 „Performance and excellence in doctoral and postdoctoral research in Romanian economics science domain”

## REFERENCES

- [1] Istudor, N., Petrescu Irina Elena, 2015, Influence of accessing European funds for rural development over the credits for agricultural sector in Romania, Quality – Access to Success, 16 (S1), p. 4-8
- [2] Lădaru Georgiana Raluca, Beciu, S., Vlad Ionela, 2014, Analysis on the evolution of surfaces under vine in Romania (2003-2013), Scientific Papers. Series “Management, Economic Engineering in Agriculture and rural development”, Vol. 14 (4):153-156.
- [3] Lădaru Georgiana Raluca, Beciu, S., 2014, Influence Of The Financial Supporting System On Romanian Wine Sector Competitiveness, Proceedings of Multidisciplinary Academic Conference, Prague
- [4] Nicolescu, O., Nicolescu, C., 2013, Entrepreneurs’ perceptions of the state implication in the business environment modelling in Romania, Transylvanian Review of Administrative Sciences, No. 38 E, p. 106-124
- [5] Organisation Internationale de la Vigne et du Vin, 2014, The wine market: evolution and trends
- [6] Thach L., Matz T., 2008, Wine: a global business, Miranda Press, New York, p.2-4
- [7] Scott Linda, Vollrath, T, 1992, Global Competitive Advantages and Overall Bilateral Complementarity in Agriculture, Statistical Bulletin 154792, USDA, Economic Research Service



## THE ROLE OF FRUIT GROWING IN THE DEVELOPMENT OF THE AGRI-FOOD SECTOR OF THE REPUBLIC OF MOLDOVA

Aurelia LITVIN, Ludmila DOBROVOLSCHI

State Agrarian University of Moldova, 42 Mircesti Street, MD-2049, Chisinău, Republic of Moldova, Phone: +37322432432, Emails: a.litvin@uasm.md, l.dobrovolschi@uasm.md

*Corresponding author:* a.litvin@uasm.md

### *Abstract*

*The fruit growing occupies an important place in the national economy of the Republic of Moldova: fresh and processed products provide about 8% of the income from exports, outpacing other sectors of the economy. However, its potential is not used efficiently because of the limited absorption capacity of the internal market, low competitiveness, as well as because of the embargo on imports imposed by Russia, the main export market for Moldovan horticultural products. In this context, the role of the fruit growing sector and its contribution to the development of the agri-food sector and economic prosperity of the Republic of Moldova is very up-to-date. The evaluation of the development level is made through the analysis of official statistical data and those obtained during field studies.*

*Key words:* agri-food sector, evolution, fruit growing, internal market

### INTRODUCTION

One of the main branches of agriculture and economy of the Republic of Moldova was and still remains the fruit growing sector. Fruit growing is a branch of the agri-food sector, which provides people with fresh products and the manufacturing industry with raw materials. The importance of the fruit growing branch for the food industry and its multiplier role in country's economy, by generating demand and stimulating the creation of added value in other branches of the national economy, contributes to its ranking among the main and strategic branches of the national economy.[4]

Fruit growing represents the essential source of income for most of country's population, being the core business of the majority of the 323,000 people employed in agriculture, while the fresh and processed fruit growing products provide about 8.4% of revenue from exports (2013). Substantial increases have been recorded in fruit exports, which in 2013 compared to 2009 constituted 62.6% and compared to 2012 - only 0.8%.[8]

However, the potential of this sector is used ineffectively because of the limited absorption capacity of the local market, low competitiveness of products on the sale

markets and because of the Russian Federation's embargo on the imports of horticultural products.

In this context, it is worth to pay special attention to the development of this sector in order to increase the competitiveness of domestic fruit products, which will have a positive impact on increasing its marketing degree and facilitating the efficient use of their potential.

### MATERIALS AND METHODS

In this article it was undertaken an assessment of the evolution level and prospects of the fruit growing development in the Republic of Moldova by official internal and external statistical data analysis, of the Republic of Moldova.

The analysis period undertaken in this study is 5 years (2009-2013) and the following research methods have been used: monographic method, method of relative value, comparison, economic analysis and synthesis.

### RESULTS AND DISCUSSIONS

On average, the share of agriculture, hunting and forestry in the gross domestic product of

the Republic of Moldova in the period 2009-2013 is about 12%. [10]

The analysis of agricultural products evolution in terms of value in the period 2009-2013 (Figure 1) shows an increase of 79.1% in 2013 compared to 2009 and of 19.5% compared to 2012, which can be considered as a positive moment for the development of the agri-food sector of the Republic of Moldova, which is traditionally an agricultural country.

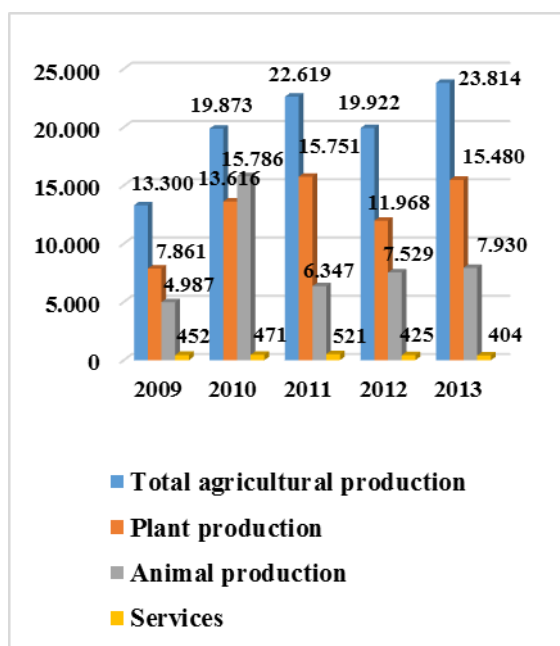

Fig.1. The evolution of agricultural production in all types of farms, million MDL, current prices  
 Source: Adapted by the authors based on the electronic data of the NBS of the Republic of Moldova.

The dynamic increase of the total agricultural production is largely due to the increase of the plant production by 96.9% and 29.3% respectively in 2013 compared to 2009 and 2012. The value of animal production also recorded an increasing evolution but at lower rates, respectively by 59.0% and 5.3%, while the sector of services decreased by 10.6% and 4.9% respectively during the analyzed period. In order to reflect the share of plant production, as well as the share of fruits, walnuts and berries in the total agricultural production, we will observe and analyze the data presented in table 1.

In Moldovan agriculture, the correlation between plant and animal production in 2013 has changed dramatically, constituting 72.3%

to 27.7%.

Table 1. The structure of agricultural production by branches in all types of farms, %

Indicators	Year				
	2009	2010	2011	2012	2013
<b>Agricultural production, total</b>	100	100	100	100	100
<b>Plant production, of which</b>	<b>68.1</b>	<b>66.2</b>	<b>67.7</b>	<b>59.3</b>	<b>72.3</b>
-cereal crops	18.4	18.8	18.4	11.6	28.9
-sugar beet	1.0	2.3	1.5	2.0	2.4
-tobacco	0.4	0.6	0.4	0.3	0.2
-sunflower	5.9	7.3	7.7	6.9	12.7
-potatoes	4.9	4.9	5.8	3.9	2.4
-vegetables and pumpkin crops	7.6	7.4	7.8	6.3	5.5
<b>-fruits and berries</b>	<b>4.0</b>	<b>3.9</b>	<b>4.8</b>	<b>5.5</b>	<b>5.4</b>
-grapes	18.7	12.1	14.4	15.8	9.0
-fodder crops and others	7.2	8.9	6.9	7.0	5.8
<b>Animal production</b>	<b>31.9</b>	<b>33.8</b>	<b>32.3</b>	<b>40.7</b>	<b>27.7</b>

Source: Adapted by the authors based on the electronic data of the NBS of the Republic of Moldova

According to data presented in the table, we found a decrease in the share of plant production in the total agricultural production in dynamics from 68.1% in 2009 to 59.3% in 2012, while in 2013 it increased by 4.2. p.p. compared to 2009 and by 21.9 p.p. compared to 2012.

The production of fruits, walnuts and berries has a share of 5.4% in the total agricultural production in the last year of analysis, recording some unessential oscillations from year to year. Although the fruit growing share in the total agricultural production isn't at the highest level as other branches of plant production, still the fruit growing branch is the branch that generates a considerable income in the total income obtained from agriculture, fact which confirms that the fruit growing branch has always played an important role in the development of the agri-food sector and economy of the Republic of Moldova.

The fruit growing branch continues to maintain a growth potential, even if it is insufficiently valorized. [5]

Table 2. Dynamics of area and production of the fruit tree plantations in all types of farms, in the period 2009-2013

Years	Total area, thousand ha	Of which fruit-bearing plantations, thousand tonnes	Global production, thousand tonnes	Average harvest, tonnes/hectare
2009	115	96	308	3.2
2010	116	94	322	3.3
2011	119	94	378	4.0
2012	120	95	380	3.9
2013	122	90	419	4.6

Source: Elaborated by the authors based on the electronic data of the NBS Republic of Moldova.

Based on data presented in the table above, we can see, according to the dynamics of the analyzed years, an increase in the total area of fruit tree plantations, as well as of the global production and average yield per hectare. Thus, we concluded that the total area of orchards increased by 6.1% in 2013 compared to 2009, global production - by 36% and the average yield per hectare - by 43.8%. Only the area of fruit bearing plantations suffered a reduction of 6.2% or 6,000 ha, which led to the deforestation of certain areas of orchards because of their ageing.

Taking into consideration all these aspects, the fruit growing sector in the Republic of Moldova has a major impact on the whole rural economy, since the fruit growing remains the most important activity in rural areas and represents an essential source of income for the agricultural enterprises activating in this field. [3]

According to the authors, the evolution of orchard areas' distribution by varieties in all types of farms presents a special interest.

As we can see in figure 2, the highest level, in total areas of fruit tree plantations, is recorded by the seedy fruit orchards throughout the whole period of analysis. Also, we observed a constant level of the seedy fruit orchards' area (66-67 thousand hectares) in dynamics, which represents, on average, a share of 56% of the total area of fruit tree plantations.

The second place is occupied by the stone fruits holding an area of 40,000 ha on average in 2009-2013, and recording a share of approx. 34%.

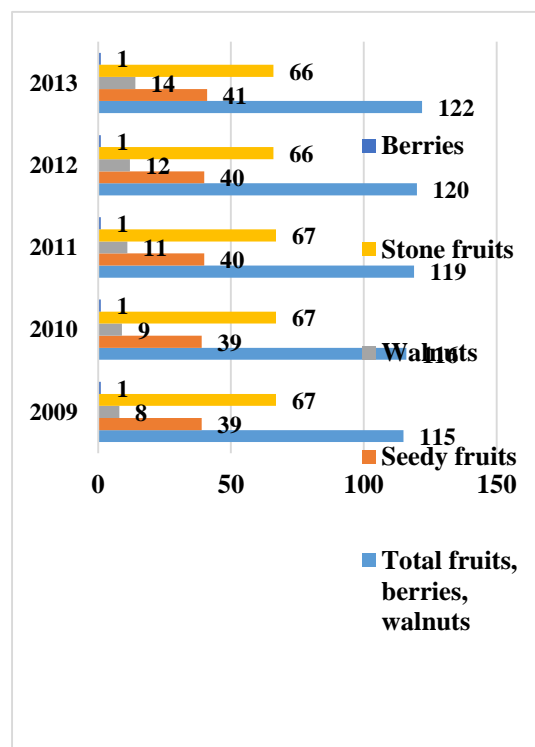

Fig. 2. The evolution of fruit tree plantations' area by species, in all types of farms, in the Republic of Moldova, in the period 2009-2013, thousand ha

Source: Elaborated by the authors based on the electronic data of the NBS of the Republic of Moldova.

The area of stone fruit plantations, in dynamics, increased slightly from 39,000 ha (in 2009) to 41,000 ha (in 2013), or 5.1% in relative value. A significant trend of growth in dynamics is observed in the case of walnut plantations area, from 8,000 ha in 2009 to 14,000 ha in 2013, or by 75%.

The average share of walnuts in the total area, during the analyzed period, constitutes about 9.1%. Thus, we conclude that one of the priorities of Moldovan fruit growing sector, designed to contribute significantly to the growth of the national income and equilibrate the balance of payments by increasing exports of high added value products, is to extend and enhance the production of walnut plantations, which are highly demanded throughout the world, especially in Europe, in increasing proportions and at reasonable prices. Nutritional value, and especially, the calorific value of this fruit tree species, creates a keen interest for the consumption of fresh fruits, with the purpose of restoring the biological potential of the population, but also as raw material for further development of the food

industry.

As for to the area of berry plantations, we noted, that it occupies an insignificant surface in the total area of fruit tree plantations, throughout the analyzed period (1 thousand ha), or an average share of 0.84%.

Generally, the national patrimony of the fruit growing sector in the Republic of Moldova is traditionally mostly formed by the seedy and

stone fruit tree species, with increasing trends in walnuts growing, all these fruit tree species being important due to the nutritional and taste, therapeutic and prophylactic value of these fruits, but particularly due to the high economic value.[1]

The use of Moldovan fruit growing production can be analyzed based on data and indicators presented in the following table:

Table 3. Dynamics of the fruit growing production use in the Republic of Moldova in the period 2009-2013

Year	Fruit production (including walnuts and berries), thousand tonnes	Import, thousand tonnes	Export, thousand tonnes	Personal consumption of the population, thousand tonnes	Personal consumption per capita, kg/year	The level of self-supply, %
<b>2009</b>	<b>308</b>	<b>54</b>	<b>317</b>	<b>109</b>	<b>30.5</b>	<b>213.9</b>
2009/2008, %	83.01	101.9	144.7	83.2	83.1	-8.3 p.p.
<b>2010</b>	<b>322</b>	<b>66</b>	<b>316</b>	<b>122</b>	<b>34.3</b>	<b>207.7</b>
2010/2009, %	104.5	120	99.7	11.9	112.5	- 6.2 p.p.
<b>2011</b>	<b>378</b>	<b>71</b>	<b>345</b>	<b>123</b>	<b>34.6</b>	<b>237.7</b>
2011/2010, %	117.4	117.8	109.2	100.8	100.9	+30 p.p.
<b>2012</b>	<b>380</b>	<b>62</b>	<b>271</b>	<b>122</b>	<b>34.3</b>	<b>245.2</b>
2012/2011, %	100.5	87.3	78.6	99.2	99.2	+7.5 p.p.
<b>2013</b>	<b>419</b>	<b>61.4</b>	<b>376</b>	<b>124.8</b>	<b>35.1</b>	<b>264.2</b>
2013/2012, %	110.3	99.0	138.7	102.3	102.3	+19 p.p.
<b>2013/ 2009, %</b>	<b>136.0</b>	<b>113.7</b>	<b>118.6</b>	<b>114.5</b>	<b>115.1</b>	<b>+50.3 p.p.</b>

Source: Elaborated by the authors based on the electronic data of the NBS of the Republic of Moldova

Thus, we observed that in 2013 compared to the basic year - 2009, the values of all indicators characterizing the use of fruit growing production are increasing. The physical level of the total fruit production increased by 36% in 2013 compared to 2009. The volume of fruit production that entered in the Republic of Moldova, also registered an increase of 13.7%, while the exported fruit tree production, during the analyzed period, underwent some fluctuations, but it is observed an overall increasing trend (18.6% in 2013 compared to 2009) of this indicator, which is very important for the efficiency and competitiveness of this sector.

The volume of fruit growing production used for consumption, according to the indicators – personal consumption of the population and personal consumption per capita, reflects dynamic changes in their value, but these changes confirm their increase in 2013 compared to 2009 by 14.5% and 15.1 % respectively. This proves that the increase in

the consumption level of country's population for these products is of major importance. However, if we compare the consumption per capita in the Republic of Moldova (35.1 kg/year) with the European Union's one (about 95 kg/year) [6], we conclude that the peculiarity of the local small and vulnerable market, generates low income from the fruit growing production sold within the country.

The level of self-sufficiency indicator indicates to what extent the domestic fruit growing production covers all requirements or internal consumption of fruit products. According to data presented in the table, we can see that generally, in dynamics, this indicator is growing, which means that the fruit growing branch of the Republic of Moldova has a development potential.

However, the value of this indicator, which reached 264.2% in 2013, highlights a critical problem of Moldova's economy that requires urgent solutions, and namely the discovery of new sale markets.

Efficient development of the fruit growing sector can be assessed in the light of a series of indicators and coefficients. Such a coefficient is the import dependency ratio (IDR), which is determined by the ratio between the import and production volume plus import minus export.[7]

As a result of the calculations accomplished by the authors it was determined:

- the import dependency ratio in 2009 - 120% ;
- the import dependency ratio in 2013 – 58.8%.

Thus, the decrease of 61.2% of this coefficient in 2013 compared to 2009 can be considered as a positive one for the economy of the fruit growing branch.

The fruit growing branch is one of the strategic branches in agriculture and economy, with a considerable share in export of the Republic of Moldova.[2]

For a clearer view on the foreign trade development of the fruit growing production in the Republic of Moldova, in the analyzed period, the authors proposed the diagram 3.

According to figure 3, there are dynamic oscillatory changes both in the import and

export of the fruit growing production in natural value. But, it is worth to notice the increase of 18.6% of the fruit growing production volume exported in 2013 compared to 2009 and the decrease of 12.9% in imports.

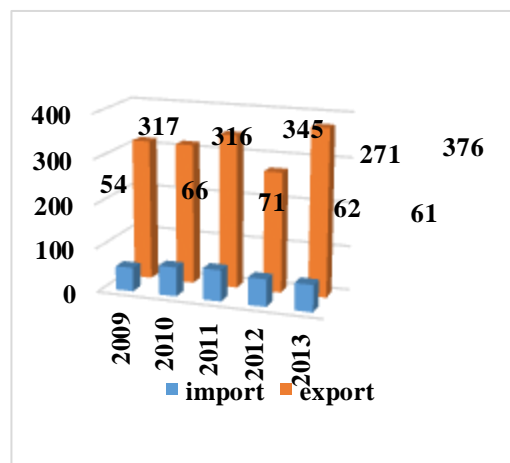

Fig. 3. Foreign trade evolution of the fruit growing production in the Republic of Moldova (in physical value), thousand tonnes, in the period 2009-2013

Source: Elaborated by the authors based on the electronic data of the NBS of the Republic of Moldova.

Table 4. Trade balance dynamics of the agri-food products trade in the Republic of Moldova, in the period 2009-2013, thousand US dollars

	YEAR						
	2009	2010	2011	2012	2013	2013 / 2009 (%)	2013 / 2012 (%)
<b>TRADE BALANCE – total, thousand US dollars</b>	<b>-1,995.2</b>	<b>-2,313.8</b>	<b>-2,974.5</b>	<b>-3,051.3</b>	<b>-3,064.1</b>	<b>153.6</b>	<b>100.4</b>
of which:							
Live animals	-7.7	4.4	2.4	1.1	-1.5	19.5	-136.4
Meat and meat preparations	-12.0	-17.3	-9.3	-20.2	-26.8	223.3	132.7
Dairy products and eggs	-16.7	-20.3	-23.7	-30.2	-35.5	212.7	117.9
Fish	-29.1	-33.3	-37.3	-41.7	-43.5	149.5	104.3
Vegetables	-20.8	-21.4	-13.6	-16.8	-19.9	95.7	118.5
<b>Fruits</b>	<b>85.2</b>	<b>109.6</b>	<b>118.5</b>	<b>133.6</b>	<b>136.9</b>	<b>160.7</b>	<b>102.5</b>
Cereals	57.0	61.3	61.9	-23.9	108.1	189.6	452.3
Milling products	-24.8	-25.7	-37.0	-40.2	-35.9	144.8	89.3
Sugar, sugar-based products, honey	20.4	16.5	-8.4	4.3	-7.1	-34.8	-165.1
Coffee, tea	-7.9	-9.1	-11.0	-10.8	-11.7	148.1	108.3
Beverages (alcoholic and non-alcoholic)	111.6	133.2	131.0	146.7	176.2	157.9	120.1
Raw and processed tobacco	-72.5	-64.3	-64.2	-48.8	-50.653	69.9	103.9

Source: Elaborated by the authors based on data presented in the Trade Map. [http://www.trademap.org/Product\\_SelCountry\\_TS.as](http://www.trademap.org/Product_SelCountry_TS.as)

In order to highlight the role of the fruit growing branch of the Republic of Moldova in the development of country's agri-food sector, one should consider another very

interesting research focused on the analysis of the trade balance performed by main commodity groups, according to the Standard International Trade Classification (SITC).[9]

Analyzing data presented in the table 4, we observe that the trade balance value of the Republic of Moldova, in the analyzed period, is negative. The dynamics of trade balance development for agri-food products is fluctuating, though largely having an increasing trend. Since 2009, it decreases from year to year, reaching in 2013 the value of US \$ 3,064.1 million.

This can be considered as negative. If you take into account that Moldova is an agricultural country, then the situation is extremely alarming and has a question mark: what kind of agricultural country we are? This fact tells us that the Republic of Moldova imports more agri-food products than it exports, which is not a benefit to its economy. However, the trades balance records positive values for such product categories as fruits, cereals and alcoholic beverages throughout the analyzed period.

Dynamic growth of the fruit trade balance by 60.7% and 2.5% in 2013 compared to 2009 and 2012 respectively, confirms once again the strategic importance of the fruit growing sector in the economic development of the Republic of Moldova. The lower growth rate in 2013 compared to 2012 is largely due to the changes that have occurred in the trade regime with the key-partners and insufficient adjustment of Moldovan fruit growing production to EU standards that prevent its access to this market.

## CONCLUSIONS

The analysis of Moldova's fruit growing sector in the light of its current state and development prospects emphasizes the significant importance of this branch for the economic development of country's agri-food sector: increased global production volume, increased average yield per hectare, positive trade balance and trends of its growth, etc.

At present, the Republic of Moldova faces difficulties in terms of efficient use of this potential. This is a result of changes in trade relations with the key partners.

In order to valorize the opportunities offered by the European markets, local fruit growing producers have to adjust their production to

EU standards, to direct their fruit growing products offer to the long-term purpose and in the quantities needed for a sustainable export.

In order to overcome the obstacles and enhance the role and competitiveness of the fruit growing sector in the Republic of Moldova, we consider it necessary to attract investments, improve the subsidy policy, increase its efficiency, as well as to develop the fruit growing branch by improving its export performance.

## ACKNOWLEDGEMENTS

This article was written within the project "Sustainable development of the horticultural sector in the context of economic security of the Republic of Moldova" under the state program "Economic security in the context of regional and European integration of the Republic of Moldova".

## REFERENCES

- [1] Babuc, V., Gudumac, E., Pesteanu, A., Cumpănici, A., 2013, Producerea merelor. Publishing House Focșani, Chișinău. 7-27
- [2] Babuc, V., 2012, Pomicultura. Central Publishing House, Chișinău. 10-11
- [3] Bivol, E., Ciubotaru, V., 2005, Cartea fermierului, Publishing House Continental Group, Chișinău. 127-146
- [4] Cîmpoies, G. 2012. Cultura mărului, Publishing House Bons Offices, Chișinău. 9-13
- [5] Cîmpoies, D., Litvin, A., 2013, Exportul producției horticole. Practical Guide. Publishing House SAUM, Chișinău. 5-15
- [6] Fala, A., 2010, Afaceri în pomicultură. Central Publishing House, Chișinău. 24-36
- [7] Garabagiu, A., 2013, Balanțele resurselor alimentare și utilizării lor: metodologia și asigurarea informațională. 1-19
- [8] Horticulture Development Program (2013-2020), 18.02.2013 (preliminary version)
- [9] Litvin, A., 2014, Promotion management of the agri-food production export (the case of the Republic of Moldova)", Doctor Habilitatus Thesis, SUAM, Chișinău, 115-186
- [10] Statistical yearbooks of the National Bureau of Statistics of the Republic of Moldova for the years 2009 - 2013

## THE PROBLEMS OF THE EXPORTERS FROM REPUBLIC OF MOLDOVA RELATED TO THE MANAGEMENT OF EXPORT PROMOTION

Aurelia LITVIN, Natalia DELIU

State Agrarian University of Moldova, 42 Mircesti Street, MD-2049, Chisinau, Republic of Moldova, Phone: +37322432432, Email: a.litvin@uasm.md, n.deliu@uasm.md

*Corresponding author:* a.litvin@uasm.md

### **Abstract**

*Moldova is one of the smallest European countries, with an appropriate sales market. Because of the decline in agriculture in recent decades, domestic sales became even smaller. In this way the sustainable development of agriculture could only be based on export promotion. It is absolutely clear the urgent need to diversify the range of exported products and markets. Sustainable development of the country depends on the ability to develop those branches of the national economy, which represent a great export potential of the country. The analysis is based on research management issues promoting the export of agricultural products from Moldova and its prospects for improvement. The methodology for conducting research is to investigate business managers. The direct contact method was used in the investigation. Most enterprises export their products to CIS countries, especially to Russian Federation, Ukraine and Belarus. As for the EU countries, the most requested are Germany, Romania, and Italy. One of the basic problems our exporters face on the foreign markets is that most products are not competitive compared to those of the origin country. We can say that, there are numerous problems encountered by local exporters. And they need support from the state in order to achieve a successful export.*

*Key words:* competitiveness, export, foreign economic relations, management, promotion, quality

### **INTRODUCTION**

Moldova is one of the smallest European countries. Agriculture is one of the driving forces that form the image of Moldova, nature and culture of the country for several centuries. [6]

Agriculture in Moldova traditionally serves as a safety belt, which ensures the existence of a cash income source from sales of agricultural products.

Because of the decline in agriculture in recent decades, domestic sales became even smaller.[2]

Developing a competitive and effective country depends directly on the insurance of favorable conditions for producers, stimulating the export of agri-food products and attracting investments. [4]

In this way the sustainable development of agriculture could only be based on export promotion. [3]

### **MATERIALS AND METHODS**

The analysis is based on research management

issues promoting the export of agricultural products from the Republic of Moldova and its prospects for improvement.

The research was conducted in different regions of Moldova. Mostly, the questionnaires have been completed by the local producers who export agricultural products.

The methodology for conducting research was focused on investigating business managers.

The direct contact method was used in the investigation.

### **RESULTS AND DISCUSSIONS**

It is absolutely clear the urgent need to diversify the range of exported products and sale markets. Sustainable development of the country depends on the ability to develop those branches of the national economy, which have a great export potential. [5]

In order to study and obtain information on the business of agri food enterprises and their main problems it was made a questionnaire.

One of the conditions for participating in the investigation was the principle of confidentiality.



The questionnaire contains 22 questions divided into three sections (Fig. 1).

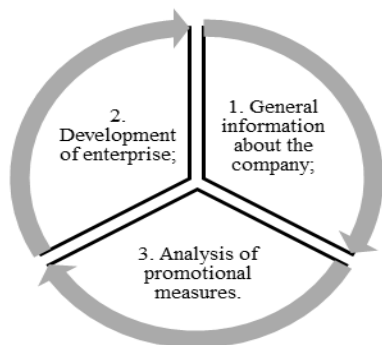

Fig.1. Compartments of the questionnaire

The questionnaire was elaborated in the way that would enable the analysis of obtained results and show the problems encountered by local exporters in the activity.

The questionnaire was completed by 75 local exporters who produce and export the following products:

- ✓ honey and apiarian products,
- ✓ sweets,
- ✓ dairy products,
- ✓ vegetables,
- ✓ sunflower oil,
- ✓ cereals, etc.

The entrepreneurs should determine two main targets: which markets they have to penetrate and how to enter the chosen markets.

The most attracting sale markets for the majority of our respondents are the following:

- CIS countries - 55%
- EU countries - 30%
- USA - 10%
- Other countries - 5%. [3]

Most enterprises export their products to CIS countries, especially to the Russian Federation, Ukraine and Belarus. As for EU countries, the most requested markets are those from Germany, Romania and Italy. [9] CIS markets are the most popular because, firstly, the requirements for quality goods differ from those submitted by the European Union and, secondly, the language of communication is better known. [7]

In order to survive in the competition, the products offered on these markets must be competitive. One of the basic problems our exporters face on the foreign markets is that

most products are not competitive compared to those of the origin country. This problem is quite severe in European Union.

Figure 2 presents the most common barriers local producers encounter when exporting agri-food products.

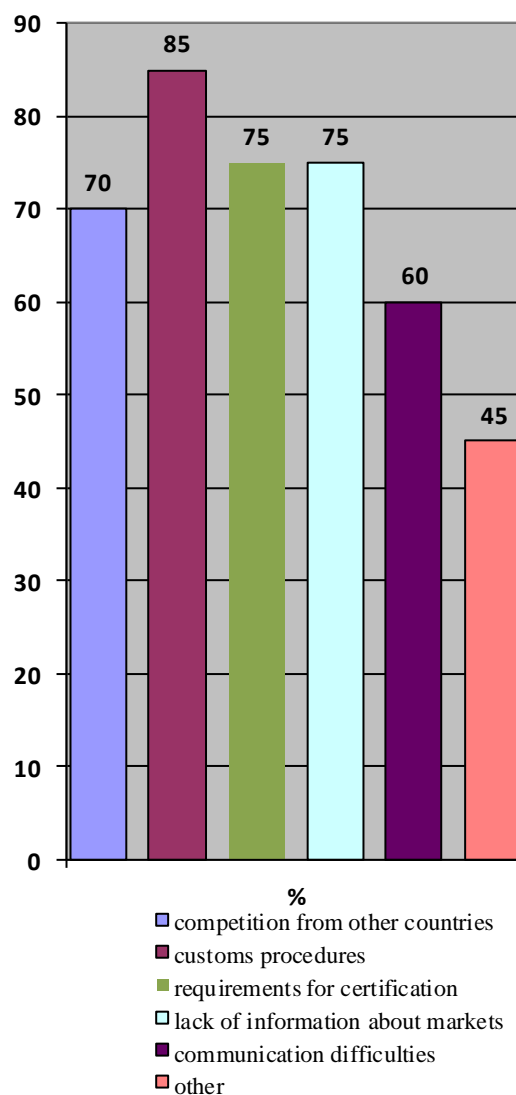

Fig.2. Factors that negatively affects foreign market penetration

Source: Authors' calculations.

Cultural differences and, especially, language level skills also play a significant role in the success of a business.

Other problems that have been mentioned most of all are the following:

- The lack of state support,
- The undeveloped infrastructure of export promotion,
- Imperfection of national legislation etc.

In order to be successful on the foreign



markets, the country needs not just to produce more quality goods, but also the goods required on the market.

One of the measures that would help Moldova's economy to compete in the contemporary environment is promoting local quality goods and services on the foreign markets. [1]

In order to strengthen Moldova's image and promoting agri-food products on the foreign markets runs, it is necessary to carry on a series of promotional measures as international exhibitions and permanent economic exhibitions within Moldova's embassies.

In addition to this, local producers propose a series of measures required for a successful export, which are presented in Figure 3.

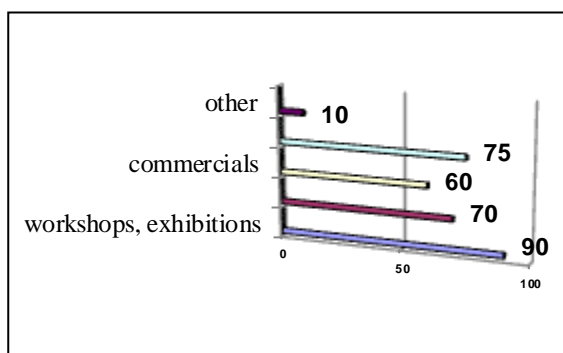

Fig.3. Necessary measures for export promotion  
 Source: Authors' calculations.

The most effective promotional measure, according to the exporters, is organizing round tables and exhibitions.

Among the factors stagnating the export, the majority of exporters mentioned the occurrence of different barriers both internal and external (Fig. 4). [3]

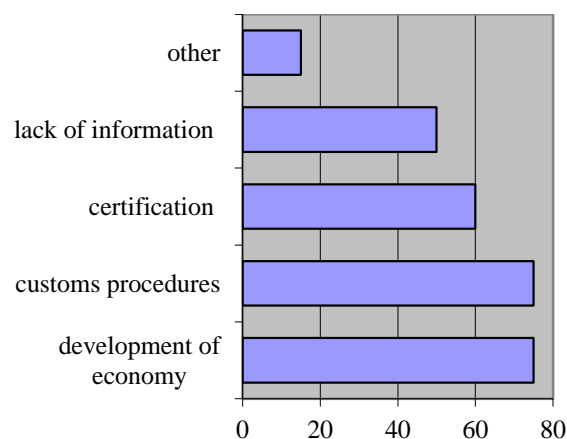

Fig.4. Internal barriers hindering the export development

Source: Authors' calculations.

The level of economic development of the country has a great influence on the activity of each entrepreneur. [8]

75% of respondents believe that the low level of our country's economy represents an important barrier for export development.

Another internal barrier that occurs in export activity is related to customs procedures. 75% of respondents think that customs procedures are too complicated.

Requirements for certification are considered by 60% of respondents as a quite serious barrier.

50% of respondents believe that another barrier for their export development is connected with the lack of information about foreign markets. We should mention that in this case, the entrepreneurs should work by themselves, i.e., to seek independently different sources of information about foreign markets.

15% of respondents indicated other internal barriers that negatively affect export development, such as:

- ✓ delayed tax refund;
- ✓ excessive controls by various government agencies;
- ✓ internal political situation etc.

Further we present what external problems local exporters face in their foreign economic activity (Fig. 5). [3]

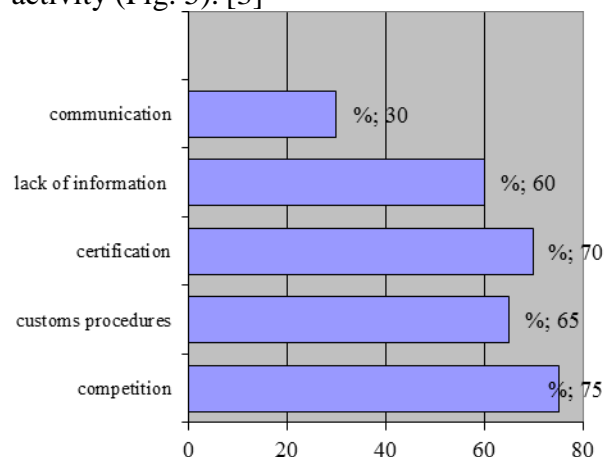

Fig.5. The problems which intervene in foreign economic activity

Source: Authors' calculations.

The information presented in Figure 5 confirms the fact that local exporters face practically the same problems as on the

internal market, except competition, especially occurring on the foreign market. [3]

Materialele simpozionului științific internațional „Agricultura Modernă – Realizări și Perspective”, UASM, Chișinău, vol. 37, Economie, Plant  
[9] [www.statistica.md](http://www.statistica.md)

## CONCLUSIONS

There are numerous problems encountered by local exporters.

In order to have a successful export the following support measures from the state are required: improving the legislative base; reducing bureaucracy; solving internal problems; granting subsidies for renewable energy sources; making state orders for agricultural products; granting cheap loans; removal of export barriers; repatriation of capital; keeping the rate “0” on reinvested profits; adjustment of national legislation to European standards; granting grants for development; granting aid in finding business partners; agricultural products insurance; forest fund and general environmental protection etc.

## REFERENCES

- [1]Cimpoieș, D., Litvin, A., 2013, Exportul producției horticole, ghid practic. Chișinău, 24-36
- [2]Furdui Viorel, 2008, Reglementarea exportului de produse agricole in Republica Moldova: Evoluții și probleme actuale, 8-13
- [3]Litvin Aurelia, 2014, „Managementul promovării exportului de produse agroalimentare (cazul Republicii Moldova)”, teza de doctor habilitat, 180-220
- [4]Litvin, A., 2010, Analiza cadrului regulatoriu al reglementării exportului de produse agroalimentare. Revista teoretico - științifică Economie și Sociologie, IEFS, nr. 4, Plant
- [5]Litvin, A., Cotici, V.V., Cotici, V.N., Gangan, S., 2013, Managementul exporturilor produselor agroalimentare din Republica Moldova. UASM, Chișinău: Centrul editorial al UASM, 58-69
- [6]Litvin, A., Deliu, N., 2011, Analysis of measures for attracting foreign investments in the Republic of Moldova. In: Scientific Papers, series “Management, Economic Engineering in agriculture and rural development”, University of Agricultural Sciences and Veterinary Medicine Bucharest, Volume 11, Plant
- [7]Litvin, A., Dobrovolschi, L., 2013, The effects of globalization on the foreign trade. In: Scientific papers, series „Management, economic engineering in agriculture and rural development”, University of Agricultural Sciences and Veterinary Medicine Bucharest, Volume 13, Issue 2, Plant
- [8]Litvin, A., Dobrovolschi, L., 2013, Subvenționarea - ca modalitate de susținere și promovare a antreprenoriatului rural în Republica Moldova.

## MANAGEMENT OF THE IRRIGATION SYSTEMS IN ROMANIA BETWEEN 1990-2014. STUDIES, PROJECTS, STRATEGIES

Aurel LUP, Liliana MIRON

Ovidius University, 124, Mamaia Avenue, 900572 Constanța, Romania, Phone: +40241 618372, +40 0241 511512, Emails: luparel@yahoo.com, miron\_stroe\_liliana@yahoo.com

*Corresponding author:* luparel@yahoo.com

### *Abstract*

*At the end of 1989, over 3 of 5.5 million ha were fitted with irrigation systems, namely more than 1/3 of the Romanian cropland. At that date, Romania was third in Europe after Spain (3.3 million ha) and Italy (3.14 million ha), countries with larger croplands, over 2.2 times and 20% more, respectively, but with less precipitation. At international level, Romania was on twelve place in terms of irrigated surface per capita. Annually, over 100 thousand ha were upgraded for irrigation, but many systems were left unfinished, the water transport canals unlined, lacking water measurement devices or drainage and water recirculation systems. The exploitation of the irrigation systems was also deficient, both in hydrotechnical and agrophytotechnical terms. Thus, the technical and economical parameters were not accomplished. Given these conditions, studies were initiated starting with 1990 to rehabilitate and also continue such projects of land reclamation left at various stages of execution. According to the report of a governmental commission, at the end of 1989, over 750 investment works valued at approximately 25 billion lei were in progress. In the field of irrigation, the first systems studied starting with 1990 were: Carasu, Galatui and Pietroiu with a total surface of over 300 thousand ha. Between 1992 and 1994, a joint Romanian-British team studied 100 irrigation systems and reached the conclusion that 1200-1500 thousand ha can be irrigated in Romania in conditions of economical efficiency. Also in 1994, a Japanese company studied the irrigable perimeter in south Moldavia and an American company explored the market for high-productivity irrigation equipment. (The author of this article collaborated as consultant in all these studies.) In time, there were other commissions that analyzed the irrigation situation in Romania. A greater project was finalized in 2011 by a Dutch company, found economically viable irrigation systems or parts of irrigation systems summed up to a total surface of over 800 thousand ha, a surface recommended to be included in the investment plan for the next period.*

**Key words:** analysis, irrigations, projects, strategies, 1990-2014

### INTRODUCTION

IN the middle of the 1960s (the 20<sup>th</sup> century), irrigated agriculture represented only 2.2% (approx. 230 thousand ha) of the arable surface and of the surfaces covered by plantations of grapevine and fruit trees. During the same time period, the irrigation improvements covered 9.9% of the cropland at global level; 6.6% in Europe; 22.1% in Italy; 11.2 in Spain; 2.8% in France. Beginning with the second half of the 1960s, the trend in Romania was to fit for irrigation larger and larger surfaces, so that in 1990 Romania not only recovered the gap, but the country had 3,100 thousand irrigated hectares, occupying third place in Europe after Spain (3,300 thousand ha) and Italy (3,140 thousand ha). The speed at which the irrigation equipment

was built prejudiced its quality, and numerous parts of this equipment were not finalized. Among these the following: the permeability of the water canals, the lack of water measurement devices, the lack of automation elements etc.

During the exploitation period, there were also numerous disfunctions: lack of electrical power to activate water pumping; insufficient fertilizers and pesticides or faulty management. The result: low yields and economic inefficiency. However, at the end of 1989, over 750 investment objectives were at various stages of implementation in the domain of land improvements. In terms of irrigation, the surface that should have been upgraded was 5,500 thousand ha until 1989. After 1989, nothing was developed. However, rehabilitation studies were initiated for the existing irrigation systems. This article synthesizes the most important studies of this

kind, to which the first author collaborated as co-author or consultant.

## MATERIALS AND METHODS

The material used represents the synthesis of the rehabilitation studies for the irrigation systems in Romania, as well as the conclusions of various commissions that analyzed the situation of the land improvement works, namely, the irrigation systems.

The method is chronological, starting with 1990 until 2014, and using the reports and conclusions of different teams and commissions that studied and analyzed the irrigation issue in Romania, given the conditions of market economy. The first author contributed extensively to these materials.

## RESULTS AND DISCUSSIONS

In a short period of time – 25 years – over 3 million ha were improved with irrigations, Romania being third in Europe, after Spain and Italy in this regard.

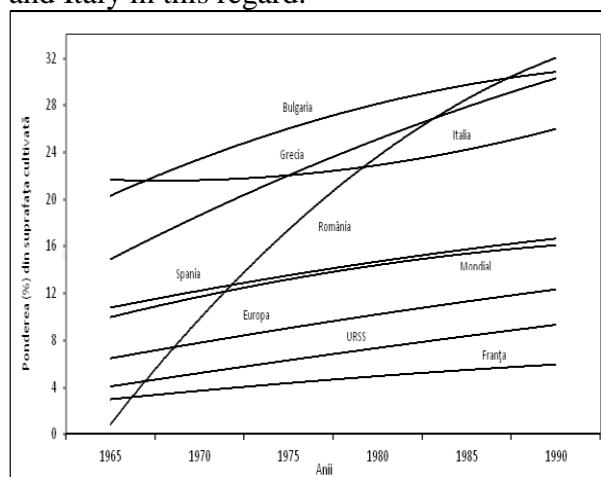

Fig.1. The evolution of irrigation development in Romania compared to the main European countries and the international trend between 1965-1990 (% of the cultivated surface)

At the same time, the irrigation ratio per cultivated surface evolved as follows: from 8.9% to 16.1% at global level; from 4.4% to 7.3% in Africa; from 32.6% to 33.3% in Asia; from 8.9% to 11.3% in Central and North America; from 3.7% to 4.9% in South America; from 8.0% to 9.9% in SUA and from 2.2% to 31.0% in Romania.

Table 1. The evolution of the surfaces improved for irrigation between 1965-1990, globally, on continents, and in some European countries and the USA

Specification	U/M	1965	1970	1980	1990
GLOBALLY	mill. ha	140.0	167.4	211.0	237.4
Africa	„	6.2	7.6	10.0	11.3
N-C America	„	20.7	21.0	27.7	26.6
South America	„	5.6	5.7	7.4	8.8
Asia	„	104.4	109.7	132.2	150.3
EUROPE	„	9.4	10.7	14.5	17.1
- Bulgaria	„	945	1,001	1197	1,263
- France	„	520	750	900	1,170
- Greece	„	576	730	961	1,200
- Italy	„	2,715	2,561	2,870	3,120
- Romania	„	230	665	2,222	3,100
- Spain	„	2,379	2,379	3,029	3,370
- Former USSR	„	2,900	11,100	17,487	21,215
USA	„	15,200	16,000	20,582	18,771

Source: The FAO Yearbooks and the Statistical Yearbooks of Romania.

At the end of 1989, over 750 land improvement works were in development in various stages of execution. However, the existing irrigation systems had numerous unfinished parts.

Table 2. The harvest estimated and harvest obtained in the main crops in 1989 in counties with an improved cropland of over 90% (kg/ha)

Crop	Estimation	Constanta county	Calarasi county	Braila county
Wheat	5,500	3,773	3,944	4,004
Maize	10,000	2,307	3,080	4,458
Sunflower	3,500	1,474	1,632	1,488
Soy	3,200	600	583	676
Sugar beet	65,000	25,938	22,054	25,129
Potatoes	38,000	11,078	7,542	12,347

Source: The Statistical Yearbook of Romania, 1990.

The precarious state of the irrigation systems and the lack of the main production factors (fertilizers, pesticides, water) led to much smaller yields than estimated (Table 2). Eventually, these results influenced negatively the economic situation of the agricultural exploitations.

Given this situation, urgent decisions were necessary regarding the continuation, cessation, conservation or rehabilitation of certain irrigation systems, which actually meant the addition of the missing parts or components. For this purpose, by an order of the Prime Minister issued on 19.12.1990, a commission of specialists was constituted in order to analyze the situation of all the land

improvement works and to make proposals regarding their future.

Among the recommendations of this commission was to rehabilitate, which in fact meant to add the unfinished parts in order to use the improvements at the estimated parameters.

**The rehabilitation of the irrigated perimeters Carasu, Galatui and Pietroiu** (Fig.2). The first evaluated irrigation systems were: Carasu located in the Dobrogea Plateau (200 thousand ha), Galatui (83 thousand ha) and Pietroiu (55 thousand ha), located in the Danube Floodplain.

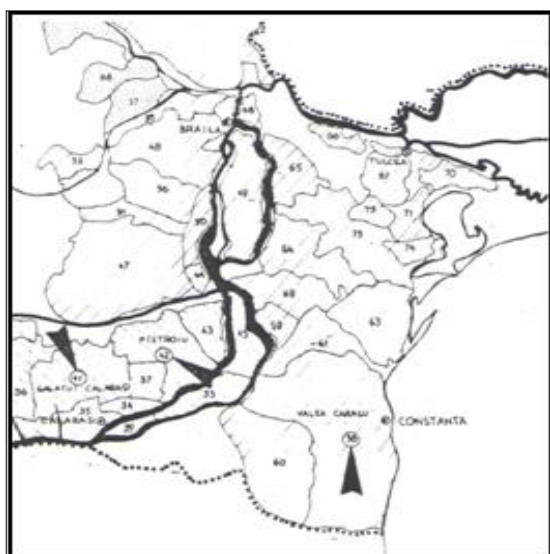

Fig.2. Location of the irrigated perimeters Carasu, Galatui and Pietroiu

The study was accomplished by a joint Romanian-French team. The Romanian side was represented by the National Institute of Research and Development for Land Improvements (ISPIF) and the Dobrogea Research Station for Irrigated Crops (SCCI), and the French side was represented by the co-ordinator team from BAS-RHONE-LANUEDOC GERSAR-NIMES.

The study took place between 1991 and 1992, and among its conclusions were the following:

-After the complete rehabilitation of the improved perimeters, the occupancy degree of the irrigated surface would be between 105-115% (while the harvest growth would be 50% in wheat, barley and sunflower; 75% in grain maize; over 100% in vegetables, sugar

beet or alfalfa<sup>5</sup>).

-The ratio of the surface actually irrigated of the total improved area was evaluated at 80%;

-The economic profitability rate calculated for a period of 45 years was 12-8% for Pietroiu, 10-7% Galatui and 7.5-6.5% for Carasu (3).

In parallel with the rehabilitation of the irrigation infrastructure, a study was executed regarding the control of water excess originating primarily from canal infiltrations. The cost of these works was evaluated at approximately USD 51/ha for Pietroiu, USD 64/ha for Galatui and USD/ha for Carasu (5).

When the irrigation systems were commissioned, the water transport canals were not lined (Fig. 3), so the water losses from seepage were evaluated at 23-27% of the volume of water transported during one irrigation season (4). In time, the water losses from canals had other negative consequences as well. In the Pietroiu-Stefan cel Mare system, for example, after 20 years of exploitation, the level of the ground water had risen from a depth of 10-15 m to near the surface, so that some areas turned into marshes and ponds (4).

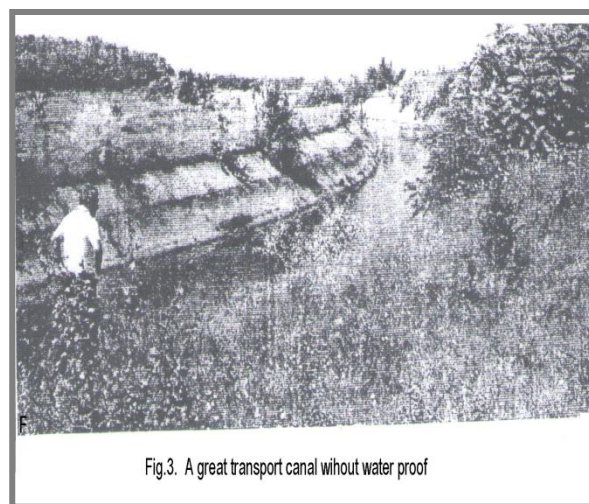

Fig.3. A large transport canal without water proof

Fig.3.A large transport canal without water proof

During the first years of the great irrigation projects – the end of the 1960s and beginning of the 1970s (the 20<sup>th</sup> century) – these problems were neglected even though a large

<sup>5</sup> Data regarding the production growth, crop structure, as well as the economic parameters that are possible to obtain on the rehabilitated surface were provided by the author of the present material.



part of the irrigation systems in the Danube Floodplain were built on drained fields, over 400 thousand ha (2). At this time, the financial resources were used primarily for fitting new surfaces with irrigation systems.

After 1990, given the conditions of market economy, the state no longer found the resources needed to rehabilitate the irrigation systems so that only few surfaces were rehabilitated and the negative events disappeared because the lands were irrigated less and less. However, the irrigation problem have continued to concern the national decision factors so the analyses and studies regarding the rehabilitation and irrigation of large surfaces have continued and are still available.

***The study on Irrigations and Drainage in Romania*** (10). It was accomplished by a joint Romanian-British team between 1992-1994. The Romanian party was represented by the National Institute of Research and Development for Land Improvements (ISPIF)<sup>6</sup>, while the British side was represented by the companies BINNIE-PARTNER and HUTING TECHNICAL SERVICES LTD.

It was the most extensive study meant to analyze the technical and economical criteria of the irrigation systems built by the end of 1989, to select the most economically efficient systems and, finally, to establish a rehabilitation program for them over a period of 5-10 years.

The study was programmed for a span of 22 months between 1992-1994. The most important 97 irrigation systems were studied and analyzed, especially those from the Danube Floodplain, Dobrudja, and Moldavia (Fig. 4). The power demand for pumping water was set as a selection criterion for the most economical ones (the most important cost element), a factor that depends in turn on the average height for water pumping. For this purpose, the most important 28 irrigation systems were divided into four groups depending on the average electric energy

consumption per ha per irrigation season, thus:

I: 6 systems with reduced demand <700 kWh/ha = 196 thousand ha

II: 6 systems with medium demand 700-1400 kWh/ha = 250 thousand ha

III: 8 systems with medium-high demand 1,400-2,100 kWh/ha = 471 thousand ha

IV: 8 systems with high demand >2,100 kWh/ha = 405 thousand ha.

*Total 1,322 thousand ha*

The percentage distribution of these surfaces is: 14.9% of the surface with low demand; 18.9% of the surface with medium demand; 35.6% of the surface with medium-high demand and 30.6% of the surface with high demand.

The relationship between the power demand, pumping height and economic viability of the irrigation systems is given in Table 3.

The pumping height of 70 meters was considered the limit at which extra irrigation costs equated with the extra income obtained by the farmers from the irrigated fields, given appropriate technologies were applied (Fig.5).

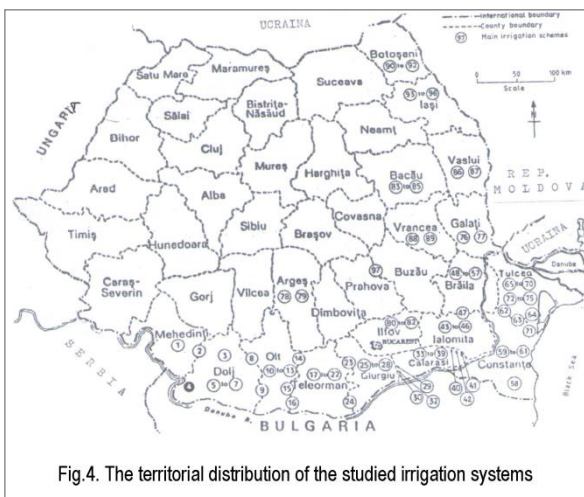

Fig.4. The territorial distribution of the studied irrigation systems

Fig.4. The distribution in the territory of the studied irrigation systems

Knowledge of the study accomplished by the team BINNIE-PARTNER & HUNTING TECHNICAL SERVICES LTD is important as it is the best documented one. This is why parts of the study were used subsequently, namely various strategies for the rehabilitation of the irrigation systems, including in the legislation in the field (the Law of Land

<sup>6</sup> The ISPIF Team provided for this study the data regarding the technical and economic parameters in the agricultural exploitation phase of the rehabilitated irrigation systems.

Improvements.

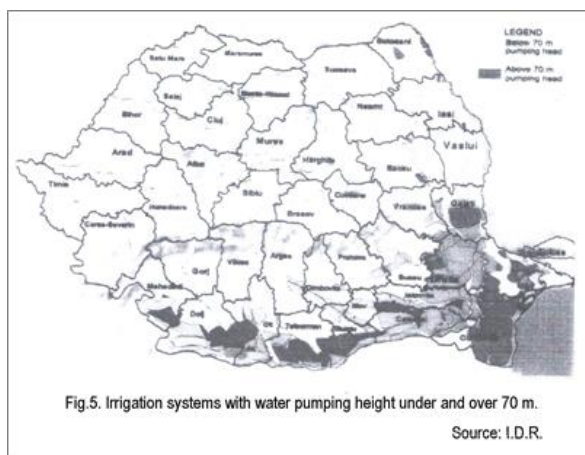

The Government Emergency Ordinance no. 147/1999 regarding the organization of the water users association). The limitation of rehabilitation to a surface of 1.2-1.5 million ha has the same origin.

Table 3. The economic viability of the surface fitted for irrigation depending on the geodesic height (Hg) compared to the level of the source water\*)

Hg(m)	Improved surface (thousand ha)	Economic viability	Cumulated surface (thousand ha)
0-10	0.50	Exceptional	0.50
10-30	0.25	Very good	0.75
30-45	0.25	Good	1.00
45-55	0.25	Satisfactory	1.25
55-65	0.25	Satisfactory/unsatisfactory	1.50
65-90	0.60	unsatisfactory	2.10
>90	1.00	Disaster	3.10

\*) In conformity to the study BINNIE & Partners Ltd. In association with Hunting Technical Services Ltd.UK and ISPIF SA (1992-1994). The viable surface = 1,361,000 ha will be rehabilitated through an investment program for the period 1995-2004.

The study had the following objectives: increase of agricultural production, promotion of market economy and limitation of state's role in the sector's administration.

The main conclusions of the study were:

- A maximum economic viability will be achieved by systems in which high maize productivity will be obtained;
- Within the cost of systems exploitation, the cost for water pumping energy will have a significant impact in their economic viability. In most systems, the cost of energy would be covered by USD 75/ha, but in some, energy + exploitation adds up to USD 100-200/ha.

-The partial retechnologization costs were evaluated differently, between USD 80-150 /ha, while the total retechnologization costs were between USD 334 and 2,500/ha.

-The farmers' capacity to bear the cost of irrigations would be regulated by differentiated tariffs, higher for state companies and the great private exploitations that would be willing to pay three times more for water than the small farmers.

-The systems in which the ratio Benefits/Costs is higher than 1.5 are appreciated as viable.

-It is believed that the beneficiaries can reduce their water demands below the limit at which its cost is equal to the value growth, but that they would be willing to pay for water 50% of this growth.

-For a production growth of 4 t/ha of maize (evaluated in 1994 at USD 120/t) all the categories of farmers could pay USD 75/ha for water).

-The state could bear a subsidy of USD 25 /ha.

The report regarding the technical, economic and financial viability contains the data necessary for the justification of the investment strategy for the following 10 years (1994-2004), for the following surfaces:

- over 1.3 million ha, of the three million fields improved for irrigation can be included justifiably in a long-term rehabilitation program;

- the surfaces covering approximately 200 thousand ha located in the Danube Floodplain that are well administered (but which yield small harvests) and located near water bodies that have a well maintained infrastructure can prove to be viable, at least in the medium term.

-The progressive backdown of governmental involvement in the administration of exploitation activities;

-The implementation of a policy of progressive reduction of subsidies for irrigations and the liberalisation of the water price as a means to balance the demand and offer and to direct the investments towards areas efficient from the economic standpoint.-

-The discouraging of irrigations when they are not viable. This aspect is essential to

minimize the subsidy costs.

In the last phase of the study (January 1994-July 1994), based on the Report regarding the technical, economic and financial viability, a ten-year investment program was prepared and it contained the following main components:

- Pilot-surfaces for demonstration;
- The rehabilitation and modernization of infrastructure, preparation, projection, rehabilitation;
- Institutional development.

In the field of Institutional Development, the study stipulated:

- The introduction of a computerized informational management system;
- The establishment of Water Users Associations;
- The development and extension of consultancy services;
- The establishment of the Program Management Unit.

During the same time period (1992-1994), two other foreign companies were interested in the rehabilitation of the Romanian irrigation systems:

- MORRISON KNUDSEN CORPORATION - USA 1992/1993 for the following areas: Giurgiu-Razmiresti, Ialomita-Calmatui, Baraganu-Basarabi (Constanta), SAI Bucharest;
- JAPAN INTERNATIONAL COOPERATION AGENCY-JICA, for the area Ruginesti-Pufesti-Panciu (Vrancea county), for 1994-1995<sup>7</sup>.

Of the over 700 investment objectives into land improvement works inventoried by the governmental commission constituted in 1990, in the field of irrigation, a surface of 218 thousand ha was in various stages of execution and was proposed for completion. Apart from this, other rehabilitation studies and projects were executed by ISPIF after 1994 for irrigation systems as follows:

- Calafat-Razmiresti (Dolj county)... 49,640 ha
- Giurgiu-Razmiresti (Giurgiu) ... 110,718 ha.
- Galatui-Calarasi (Calarasi county) ... 84,874

ha.

-Pietroiu-Stefan cel Mare (Calarasi county)... 55,400 ha.

-Valea Carasu (Constanta county)...200,000 ha

-Ialomița-Calmatui (Braila county)...140,000 ha

*Total ..... 640,638 ha.*

As a matter of fact, both ISPIF and the National Administration of Land Improvement pleaded after 1989 for the restoration of the irrigation systems on the surface existing before 1990, namely three million hectares and even more. The argumentation was Prodomo-type for both institutions, which meant work front, the maintaining of organisational structures, jobs etc. This in spite of the fact that no rehabilitation study executed after 1990 recommended the exceeding at national level of irrigable surfaces larger than 1,500 thousand ha.

**Other strategies, analyses and rehabilitation projects for the irrigation systems in Romania.**

The abolition of the planned economy and the transition to the market economy based on private land property had an important impact on the land capital, the result being the liquidation of large state and cooperative agricultural exploitations and the land retrocession to its previous owners into millions of plots that became as many exploitations.

The process lasted for several years and had a catastrophic impact on the irrigation systems whose water transport and distribution network was projected for large exploitations. Parallel to the creation of the new land exploitation structure, the irrigation systems were destroyed, including through the theft of the metallic, ferrous and non-ferrous parts. On the other hand, given the conditions of the market economy, the state subsidies for water were reduced simultaneously to the price differentiation depending on water pumping height and water transport distance. Consequently, the farmers' interest for irrigations decreased and the systems were mostly abandoned.

Even in this state, the national irrigation system represented a great patrimonial value

<sup>7</sup> The author collaborated between 1992-1994, as consultant, with both companies.



given that the climatic phenomena became more critical and irrigation represented both the guaranty of food security and an important factor of technological intensification and growth of the performances of Romanian agriculture, one of the most reduced within the European Union and not only.

Given these conditions, the government maintained its concern for the existence of an institutional legislative and economic framework meant to help the restoration, at least partial, of the irrigation systems which could thus contribute to the increase of agricultural performances. The material presents a synthesis of the most important governmental policies regarding the rehabilitation of the national irrigation system.

**The project Rehabilitation and Reform in the Irrigation Sector** was lunched in 2004 by the Law no.4/2004 (7, 8, 11, 12). Valued at USD 103 million, it was financed by BIRD (USD 80 million), the Romanian Government (USD 20,622 million) and AUI (USD 2,325 million). The purpose of the project was:

- To reduce the drought risk;
- To increase the economic efficiency of irrigations;
- To improve the management of irrigations;
- To involve the beneficiaries in the management and rehabilitation of the irrigation systems.

Practically, as a result of the project, 100 thousand ha were going to have their irrigation infrastructure rehabilitated, 40,310 ha of which in the Sadova-Corabia system (Dolj county) and 11,030 ha in the Terasa Nicoresti-Tecuci system (Galati county).

**The National Strategy for the Reduction of the Effects of Drought, the Prevention and Control of Land Degradation and Desertification (12)** was elaborated in 2007 based on the Government Resolution no.474/2004.

The specialists that collaborated to draft it came from 38 institutions with various backgrounds and degrees, among which seven ministries, two academies, 12 research institutes, six universities and others. The strategy was completed at the end of 2007.

In regards to the rehabilitation of the irrigation systems, the strategy stipulated:

-The elaboration of a *study regarding the evaluation of the working condition of the irrigation hydrotechnical systems* in the administration of ANIF with the purpose of selecting systems that can enter the rehabilitation and modernization program in a certain priority order;

-The *selection of the irrigation systems and sub-systems for the rehabilitation and modernization program* on a surface of approximately 1.23-1.5 thousand ha considered viable from the economic standpoint in the long run.

-This selection will be done in order of a priority established according to technical, economic, ecological and social criteria. The priority in this selection is held by those regions where irrigators associations are established and where there are demands for irrigations (approx. 700,000 ha according to the ANIF data), where water is available all year-round and it can be obtained with minimal energy and material expenses, where the restoration of the systems does not have great impact on the environment and where the crop structure provides, through irrigations, a considerable harvest growth. The tackling again of the irrigation rehabilitation and modernization issue is also justified by the relatively significant demand of the local communities (approx. 62% of the total questionnaires filled out, with an availability to contribute financially expressed by approx. 10%).

-The elaboration of *projection documents for the rehabilitation and modernization of the irrigation systems*, selected in order of priority. This measure will be accomplished by request of public offer and based on the specifications, and it will have the following components: 1) the infrastructure of the hydro-technical scheme for the adduction of water from the source to the interior equipment; 2) the infrastructure of the interior equipment and rigging with watering installations; 3) plantation of protective forest barriers;

-Execution of the rehabilitation and modernization works in the determined order of priority – approx. 0.75 thousand ha in the short-medium term.

-Resuming of work on the derivations suspended after 1990 (Siret-Baragan and Olt-Vedea-Neajlov canals) within a national measure to develop gravity fed irrigation systems which would ensure the irrigation of croplands with reduced power demand, as well as providing water to the areas covered;

*-Encouraging of the creation of local irrigation improvements, in correlation with the directives for the improvement and management of waters* within the sustainable development projects in the rural areas, based on the access to local water sources. This measure is necessary in order to complete the rehabilitation of the irrigation system administered by ANIF, as, unlike this one, the local systems could benefit from financing by EU structural funds. Another argument for this measure is the fact that the national irrigation system cannot respond to all the irrigation needs in agriculture (vegetable growing, sericulture, fruit growing etc).

***The Inquiry of the Parliamentary Commission regarding the Situation of the Irrigation Systems 2009***<sup>8</sup>. The objectives of the commission were:

- To verify the way in which the specialized institutions observed the conformation to the measures for rehabilitation and keeping the irrigation systems going in the affected areas;
- To analyze the situation regarding the use of the funds allotted to the irrigation systems;
- To analyze the measures taken for expediting irrigations in 2009;
- To analyze measures including legislative ones that can be taken urgently;
- To verify any other aspects incidental to this event.

On this occasion, the National Administration of Land Improvements (ANIF) presented to the commission the patrimony situation within which the irrigation improvements equated 3,001.6 thousand ha made up of 10,996 km of adduction canals, water transport and distribution, 33,550 km of buried duct networks, 3,313 basic pumping stations, repumping stations and pressure stations equipped with 20,336 pumping gear. This

patrimony was valued at 6.6 billion lei and then at Lei 5.98 billion, which means less than Lei 2,000/ha or USD 570/ha, an insignificant value compared to the one at the end of 1989.

The following are among the findings of the commission:

-The considerably reduced degree of use of the irrigation systems reported to the improved surface existing in 1989.

-Between 1991-2009 the actually irrigated surface ranged between 622,510 ha in 1996 and 45,719 ha in 2005, which represented 20 and 1.5%, respectively, of the over 3 million hectares in the ANIF patrimony. In 2003, a particularly droughty year, only 569,073 ha were irrigated and in 2007, the most droughty year of the last 60 (compared to 1945-1946), 319,998 ha were irrigated, namely approx. 10% of the theoretical potential.

Among the major causes that generated this situation are the following:

- The inadequate technical state of the irrigation systems in various stages of degradation;
- The liquidation of large exploitations and the appearance of millions of small exploitations which are not prepared and not interested in intensive irrigation technologies;
- The increasing water prices;
- The reduction of irrigation subsidies;
- The lack of irrigation equipment;

The split of SNIF into ANIF (National Administration for Land Improvements) and SNIF (National Society for Land Improvements), the last institution that provided maintenance for irrigation systems, was unanimously considered the main error of the Law no. 138/2004.

Other aspects were signalled as well:

- Inadequate ratio between the administrative staff and the productive one (favoring the former);
- Hiring personnel that is not trained in the field, including on political grounds;
- The high salary ratio within the expense structure;

Finally, the Parliamentary Inquiry Commission made a number of proposals:

- Inventory of the systems and sub-systems that can work without further investment;
- Completion of the systems or of any part of

<sup>8</sup> The author of the present material collaborated with this commission as expert.

each system that fits within the domain of economic viability;

-Granting the statute of public utility to the gravity fed irrigation systems;

-Completion of the priority list for investments of rehabilitation and modernization;

-Legislation amendments to facilitate the quick development of the Organizations for Water Users in Irrigation (OUAI) and Federations;

-The land subjected to an obvious degree of aridisation and desertification located in irrigation systems without economic viability (e.g. Dobrudja) should be treated as *disadvantaged area*;

-No compensatory payments to be accepted in the functional irrigation systems;

-Introduction of means of measurement and recording of the water volumes delivered to OUAIs;

-After the analysis, addition and completion of these proposals, the *National Irrigation Plan* should be drafted and provided with complete tasks and development span (short, medium and long term), including stipulations regarding the financial sources.

This program is included in the *Strategy of agricultural development for 2020-2030*, when irrigations would be applied on a surface of approx. 1500 thousand ha, recommended by all studies and analyses executed so far on this topic.

## CONCLUSIONS

The irrigation problem was approached at governmental level immediately after the abolition of the planned economy system, beginning with 1990. At the end of 1989, hundreds of land improvement projects were at various stages of execution and the land improved for irrigation should have reached 5.5 million ha, according to the last program launched in 1983.

There was an urgent need to decide which works should be continued, preserved or abandoned. The option for market economy required the reexamination of all the investment objectives, including those commissioned before 1990. This because

most of them were not finished and functioned at technical and economic parameters inferior to those estimated.

The irrigation systems had to be adapted to the new types of small agricultural exploitations and in economic terms, these had to function according to the rules of market economy, namely be lucrative (efficient) both for the state and for the users.

The conclusions and recommendations of the first rehabilitation studies and projects were not put into practice due to several causes:

-The lack of financial resources;

-The increase of water prices and their differentiation according to pumping heights;

-Difficulties in the organization of farms capable of practicing irrigated farming;

5.-A study executed between 1992-1994 recommended the reduction of the irrigable surface from over 3,000 thousand ha to a maximum of 1,500 thousand ha, with technologies and crop structure specific to irrigated farming.

The studies and analyses of various commissions, as well as the rehabilitation projects of irrigation systems or parts of systems continued till the present day but none of them recommended the irrigation in Romania of surfaces larger than 1500 thousand ha.

The areas recommended for rehabilitation are those in the Danube Floodplain, with small pumping heights and the systems in which there is no need for water pumping.

There are, however, opinions according to which the national irrigation system should be restored to the size existing in 1989, namely 3100 thousand ha or even more. These opinions belong to the engineers and builders of irrigation systems.

## REFERENCES

- [1]Atanasiu, V., Ursăcescu, G., 1992, Studiu privind reabilitarea sistemului de irigații Petroiu-Ștefan cel Mare. Buletin ISPIF. vol.II.
- [2]Botzan et al., Valorificarea hidroameliorativă a Luncii Dunării românești și a Deltei. București.
- [3]Coité, Cr.,1993, Rehabilitation des trois perimetres de Petroiu-Ștefan cel Mare. Gălățui-Călărași et Carasu. Editions PAIDEA. Bucharest.
- [4]Dumitrașcu, C., 1976, Observații privind evoluția nivelului freatic în Complexul Carasu. Lucrări

științifice ale SCCI „DOBROGEA”.

[5] Lavorel, C., Sauvagere, J.P., 1993, Rehabilitation des trois perimetres de Pietroiu-Ștefan cel Mare. Gălățui-Călărași et Carasu. (l'assainissement et le drainage des périmètres). Editions PAIDEA. Bucarest.

[6] Lup, A., 1996, Irigațiile în agricultura României. Ed. Agris. București.

[7] Nicolaescu, I., Buhociu, L., 2006, Evaluarea procesului de reformă a sectorului de irigații în România în context european. Al XXII-lea Simpozion SIRAR. Deva.

[8] Tușa, C.G., Cocu, C.I., 2006, Proiectul Reabilitarea și reforma sectorului de irigații. Al XXII-lea Simpozion SIRAR. Deva.

[9] x x x Anuarul statistic al României 1990.

[10] x x x Irrigation and Drainage in Romania. 1994. Binnie and Partners.

[11] x x x Reabilitarea și Reforma Sectorului de Irigații 2009. Ministerul Agriculturii, Pădurilor și Dezvoltării Rurale.

[12] x x x Strategia Investițiilor în Sectorul Irigațiilor 2011. Fidman Merkat. București.

[13] x x x Cadrul Național Strategic pentru Dezvoltarea Durabilă a Spațiului Rural Românesc 2014-2020-2030. București. 2014.

## RESEARCH ON INFLUENCE OF AGROFUNDS ON THE FODDER PRODUCTION AT PREAJBA – GORJ

Dragoș Mihai MEDELETE, Radu Lucian PĂNZARU

University of Craiova, Faculty of Agriculture and Horticulture, 19 Libertății Street, Craiova, Romania, Phone: +40251 418 475, Emails: medelete@yahoo.com; rlp1967craiova@yahoo.com

*Corresponding author:* medelete@yahoo.com

### Abstract

*It is important that pastoral fund of our country has to be preserved, provided that there is a tendency for degradation quite pronounced. Best grassland biodiversity is conserved if it uses mainly organic fertilizers, as agro funds so I experienced several models of fertilization. Experiences that take place in the Experimental Center for Culture of grasslands Preajba - Gorj County, are supported by strategic project "Support Scholarships University in Romania by the European Doctoral and Post-doctoral (SCHOLARSHIPS DOC-POSDOC)", ID 133255, making it one on natural grassland and the other on natural meadow over seeded. I used Red clover for over seeding and noticed that in the first year of experimentation (2014), total production was closely related to the amount of manure used, being less influenced by the amounts of nitrogen, phosphorus and potassium compound fertilizers.*

**Key words:** clover, fertilizer, pastures, total production

### INTRODUCTION

Approximately 70% of grasslands are spread out in the hillside, being represented mostly by type *Agrostis capillaris*.

These meadows, mostly characterized by low productivity (5-7 t / ha green mass) are mediocre in terms of quality, with the production unevenly distributed during the growing season.

As a result of modest quantity and quality of forage, meadows provide food for grazing season more than 1 LU / ha, which is very little if we take into consideration the potential natural vegetation and specific conditions. [3]

On pastures nor does it apply a work of care practiced a rudimentary and inappropriate use, which determines the vegetation and soil degradation.

Animals are introduced immediately after snowmelt, when the ground is still wet and maintained continuously until very late autumn, and if there is snow, even in the early part of the winter, the only exploitation methods known being free grazing or grazing in front. [4]

### MATERIALS AND METHODS

The Oltenia hilly area, known as the

Subcarpații Olteniei is comprised between Olt Valley and Tismanei including:

- Carpathian Basin Tismana - Polovragi;
- Carpathian hills;
- Depression intrahill Tg. Jiu – Câmpul Mare;
- Carpathian hills outside of Ciuperceni and Sârbești.

The system consists of alternating hills lower in altitude to the south and depressions developed in the form of continuous corridors. Between Motru and Gilort is the largest Carpathian basin intrahill - Tg. Jiu - Câmpu Mare, where is. Tg Jiu and rural areas as: Drăguțești, Bălești, Călnic, Ciuperceni. [1]

The Hilly region includes two categories genetically generated by tectonic movements (the folded hills) and piedmont regions formed by erosion by rivers (hillocks).

In the first category are included two rows of hills forks from Măgura Slatioarei and cross entirely The Carpathian area at West of the Olteț river, dividing it into two valleys. The second category, the erosion hills, includes the Northern edge of the Piedmont getic, some of them bordering to South the intrahilly depression Tg. Jiu - Câmpu Mare (Bujorăscu Hill) and others closed smaller erosion depressions (Cărbunești, Mira, Muierii, etc).

The climate of Oltenia hill is milder and drier than one encountered in the mountains, being

influenced by the movement of air masses south and south - western and western. Meanwhile, anticyclonic air masses from the north, lose baseline characteristics, reaching Tg. Jiu with a higher temperature and lower movement speed. [2]

Researchers describes the climate in the Carpathian area of Oltenia based on meteorological data obtained at Apa Neagră stations (latitude 45 ° 00; longitude 22 ° 49; altitude 360 m), Targu-Jiu (45 ° 02; 23 ° 17 ; 210 m) and Râmnicu Vâlcea (45 ° 06; 24 ° 22; 242 m) and through Glogova and Novaci weather stations. [6]

The amplitude of the annual air temperature is 22.5 ° C at Apa Neagră, 24.1 ° C to 23.7 ° C Târgu Jiu and the station Ramnicu Valcea and monthly averages of daily maximum temperatures range from 9.7 ° C in January and 34.7 ° C in August, while for the minimum variation is from -16.9 ° C in January to 9.4 ° C in July. [7]

Average rainfall that occurred in the area reaches 901.9 mm at Apa Neagră, 726.0 mm at Glogova, 798.0 mm at Târgu Jiu, 863.0 mm and 707.3 mm at Novaci. [6]

Submission of snow is differentiated because of wind, accumulated quantities cannot be recorded in the general area. The data recorded at Târgu Jiu station shows that the average snowfall increases from late autumn to late winter, with a maximum in the first decade of February (14.8 cm).

The hilly area of Oltenia presents a wide range of soil types due to heterogeneity factors pedogenesis. [8]

Reserchers considers that from the southern boundary of Getic Plateau to the piedmont hills are found, mainly preluvisols and luvisols representative on hilly area. [10]

Preluvisols are found on well-drained slopes, exposed to the south and were formed under forests (*Quercus cerris*) and flasks (*Quercus frainetto*), making it the characteristic clays, conglomerates and sandstones, as parental material. [9]

Type characteristic pasture, spread on important areas, including the Experimental Center for Crops and Pasture land from Preajba, is *Agrostis capillaris* with *Festuca rubra*. The two species are in a relationship of

co-dominant, depending on some factors exhibition or stationary, such as soil moisture. [5]

For solving the objectives in the spring of 2014, were two experiences placed into the field of Preajba Experimental Center - Gorj, taking into account the selection of land area representative in terms of floristic composition and terrain orography.

Placement of experiences was in blocks, each experience with 8 variants 3 repetitions.

The 8 variants were similar in all the two experiences:

Var. 1 = Witness unfertilized;

Var. 2 = 5 t/ha manure;

Var. 3 = 10 t/ha manure;

Var. 4 = 15 t/ha manure;

Var. 5 = 20 t/ha manure;

Var. 6 = 10 t/ha manure + 50 kg/ha N + 50kg/ha P<sub>2</sub>O<sub>5</sub> + 50kg/ha K<sub>2</sub>O;

Var. 7 = 15 t/ha manure + 50 kg/ha N + 50kg/ha P<sub>2</sub>O<sub>5</sub> + 50kg/ha K<sub>2</sub>O;

Var. 8 = 20 t/ha manure + 50 kg/ha N + 50kg/ha P<sub>2</sub>O<sub>5</sub> + 50kg/ha K<sub>2</sub>O.

Experiment 1 was placed on *Agrostis capillaris* natural grassland, aiming at improving it through organic and chemical fertilizers.

Experience 2 was placed on natural meadow over-seeded with Red clover, 15 kg / ha.

As complex fertilizers were used 15-15-15 so calculated and completed as to achieve the rates established by thematic and manure from cattle older than 2-3 years.

Preparing the ground for no experience. 2 consisted of multiple passes perpendicular to the disc harrow over permanent grassland until it was found that the land is partially mobilized, allowing over-seeding.

*Trifolium pratense* was used for over-seeding (Red clover) Merviot variety.

Sowing was done manually and the incorporation of seeds with a ring roller towed by tractor U 445 DT. After seeding was applied chemical and organic fertilizers.

## RESULTS AND DISCUSSIONS

In 2014, permanent grassland of *Agrostis capillaris* from Preajba - Gorj gave a yield of 2.34 t / ha dry matter (Table 1, Figure 1).

Table 1. Influence of chemical and organic fertilizers on permanent pasture production *Agrostis capillaris* in 2014 (t / ha dry matter)

Variant	Absolut prod. t/ha d.m.	Relative prod. (%)	Diff. (±) t/ha d.m.	Signif.
unfertilized	2,34	100	-	Whitens
5 t/ha manure	2,70	115	0,36	-
10 t/ha manure	2,81	120	0,47	-
15 t/ha manure	3,10	132	0,76	-
20 t/ha manure	3,30	141	0,96	-
10 t/ha manure + 50N + 50 P <sub>2</sub> O <sub>5</sub> + 50K <sub>2</sub> O	4,35	186	2,01	***
15 t/ha manure + 50N + 50 P <sub>2</sub> O <sub>5</sub> + 50K <sub>2</sub> O	4,92	210	2,58	***
20 t/ha manure + 50N + 50 P <sub>2</sub> O <sub>5</sub> + 50K <sub>2</sub> O	5,50	235	3,16	***

DL 5% = 0,97 t/ha, DL 1% = 1,35 t/ha, DL 0,1 % = 1,88 t/ha

Source: Own calculation.

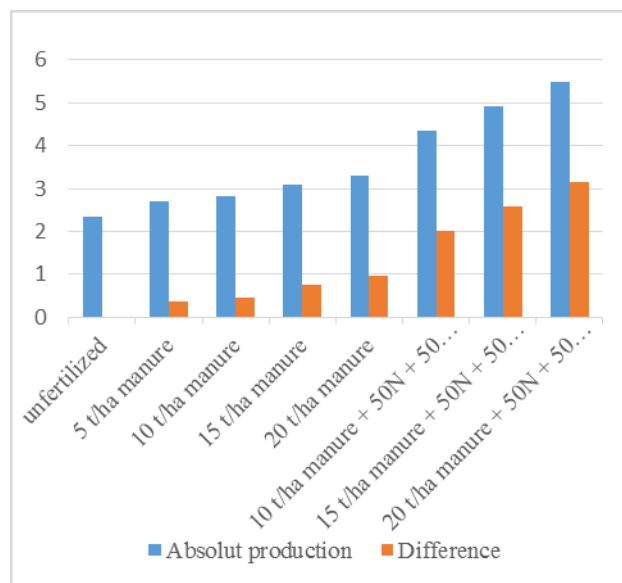

Fig. 1. Production of dry matter (permanent pasture)

Source: Own calculation.

The 7 treatments with different doses and combinations of chemical or organic fertilizers have achieved higher production, at 2.70 (manure 5 t / ha) to 5.50 t / ha d.m. (manure 20 t / ha + 50 kg N, 50 kg P<sub>2</sub>O<sub>5</sub> and 50 kg K<sub>2</sub>O). In relative numbers, increases ranged between 15 to 135% and in absolute terms, from 0.36 to 3.16 t / ha d.m. 3 of the 6 treatments production increases distinctly significant (variant 10 t / ha manure + 50N +

50P<sub>2</sub>O<sub>5</sub> + 50K<sub>2</sub>O, version 15 t / ha manure + 50N + 50P<sub>2</sub>O<sub>5</sub> + 50K<sub>2</sub>O and fertilized variant with manure 20 t / ha manure + 50N + 50 P<sub>2</sub>O<sub>5</sub> + 50K<sub>2</sub>O).

Highest production of 5.50 t / ha dry substance was recorded in organic and mineral combination treatment with 20 t / ha manure + 50N + 50P<sub>2</sub>O<sub>5</sub> + 50K<sub>2</sub>O. High yields, close to the maximum, gave variants 15 t / ha manure + 50N + 50P<sub>2</sub>O<sub>5</sub> + 50K<sub>2</sub>O (4.92 t / ha) and 10 t / ha manure + 50N + 50P<sub>2</sub>O<sub>5</sub> + 50K<sub>2</sub>O (4.35 t / ha). Other variants with manure single dose of 5, 10, 15 or 20 t / ha gave lower yields but good enough: from 2.70 to 3.30 t / ha d.m.

Gains made by these treatments were not significant.

In the case of over-seeded grassland from Preajba we obtained productions from 3.93 to 8.89 t / ha d.m. according to the treatment with chemical fertilizers and / or organic (Table 2, Figure 2).

Table 2. Influence of chemical and organic fertilizers on permanent grassland of *Agrostis capillaris* over-seeded in 2014 (t / ha dry matter)

Variant	Absolut prod. t/ha d.m.	Relative prod. (%)	Diff. (±) t/ha d.m.	Signif.
unfertilized	3,93	100	-	Whitens
5 t/ha manure	4,74	121	0,81	-
10 t/ha manure	5,56	141	1,63	*
15 t/ha manure	5,97	152	2,04	**
20 t/ha manure	7,51	191	3,58	***
10 t/ha manure + 50N + 50 P <sub>2</sub> O <sub>5</sub> + 50K <sub>2</sub> O	8,31	211	4,38	***
15 t/ha manure + 50N + 50 P <sub>2</sub> O <sub>5</sub> + 50K <sub>2</sub> O	8,89	226	4,96	***
20 t/ha manure + 50N + 50 P <sub>2</sub> O <sub>5</sub> + 50K <sub>2</sub> O	8,22	209	4,29	***

DL 5% = 1,26 t/ha, DL 1% = 1,75 t/ha, DL 0,1 % = 2,43 t/ha

Source: Own calculation.

The smallest amount of dry matter was carried to over-seeded and fertilized variant, and the

highest to treatment with 15 t / ha manure + 50N + 50P<sub>2</sub>O<sub>5</sub>+ 50K<sub>2</sub>O.

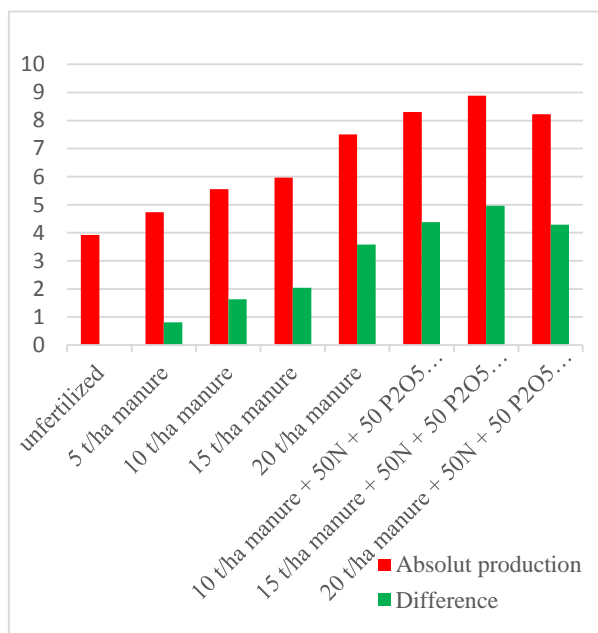

Fig. 2. Production of dry matter (over-seeded pasture)  
Source: Own calculation.

The latest treatment has recorded an increase of 4.96 t / ha compared with whitens, very significant.

High yields, close to the maximum, of more than 7 t / ha d.m gave variants 4, 5, 6 and 8 respectively treatments with 10 t / ha manure + 50N + 50P<sub>2</sub>O<sub>5</sub>+ 50K<sub>2</sub>O (8.31 t / ha), 20 t / ha manure + 50N +50P<sub>2</sub>O<sub>5</sub> + 50K<sub>2</sub>O (8.22 t / ha) and 20 t / ha manure (7.51 t / ha). At these 3 treatments production were superior to the witness by 3.58 to 4.38 t / ha d.m.

Lower yields, but good, were performed for treatments with 15 t / ha manure (5.97 t d.m) and 10 t / ha manure (5.56 t d.m) to which increase in production compared with the witness was over 1.5 t d.m

## CONCLUSIONS

The data obtained show that permanent grassland production can be greatly improved by using fertilizers. The best results were obtained with mixed organic-mineral treatment (manure + NPK), where the production was situated between 4.35 t / ha d.m to 5,50 t / ha d.m (10 t/ha manure + 50N + 50 P<sub>2</sub>O<sub>5</sub> + 50K<sub>2</sub>O and 20 t/ha manure + 50N + 50 P<sub>2</sub>O<sub>5</sub> + 50K<sub>2</sub>O).

The results of *Agrostis capillaris* grassland highlight the effectiveness of over-seeding pastures as specific method for improving the weakly productive, degraded and also demonstrates the important role of fertilizers, especially the organic and the plants sown in raising overall productive grassland.

Best results were found at variants fertilized with 15 t/ha manure + 50N + 50 P<sub>2</sub>O<sub>5</sub> + 50K<sub>2</sub>O (8,89 t / ha dry matter) and 10 t/ha manure + 50N + 50 P<sub>2</sub>O<sub>5</sub> + 50K<sub>2</sub>O (8,31 t / ha dry matter).

The floristic structure of both types of grassland has been enhanced by the appearance of valuable species, especially because of the effect it has on manure;

## ACKNOWLEDGEMENTS

This work was supported by the strategic grant POSDRU/159/1.5/S/133255, Project ID 133255 (2014), cofinanced by the European Social Fund within the Sectorial Operational Program Human Resources Development 2007-2013.

## REFERENCES

- [1]Baranovsky, N., Neamu, G., 1971, Gorj County, Academy Press R.S.R. Bucharest.
- [2]Colă, M., 2001, Research on the yield and quality of temporary pastures hilly area of Oltenia, depending on the culture system, PhD thesis, Bucharest
- [3]Ionescu, I., 2001, Permanent grassland in Northern Oltenia - Universitaria Publishing House, Craiova.
- [4]Ionescu, I., 2003, Temporary grasslands the Subcarpathian area of Oltenia, Publisher Sitech, Craiova
- [5]Medelete, D., 2009, PhD thesis, Research on technology and economic efficiency of grassland in the Subcarpathian side of Oltenia - Craiova.
- [6]Pavel, C., *et al.*, 1973, The grasslands of Subcarpathian area of Oltenia, Publisher The writing Romanian, Craiova.
- [7]Pavel, C., *et al.*, 1983, Research on determining the ratio of N / P / K for fertilizing grasslands Carpathian area of Oltenia., Annals Univ. of Craiova, vol XIV
- [8]Vasile, D., 2001, The main soils of the hills and mountains of Oltenia, Universitaria Publishing House, Craiova.
- [9]Vasile, D., Popescu, C., Grecu, F., 2007, General Pedology. Publisher didactic and pedagogical Bucharest.
- [10]Vasile, D., Popescu, C., 2003, Pedology, Universitaria Publishing House, Craiova.



## EXTERNAL FACTORS' IMPACT OVER THE AGRICULTURAL SECTOR OF THE REPUBLIC OF MOLDOVA

Victor MOROZ, Anatolie IGNAT

National Institute for Economic Research, 45 Ion Creanga Str., MD 2064, Chisinau, Republic of Moldova, Phone: +37369 148 808, Fax: + 37322 743 794, E-mails: vmoroz27@gmail.com, anatolie.ignat@gmail.com.

*Corresponding author:* vmoroz27@gmail.com

### **Abstract**

*Over the past ten years, Moldova's economy has gone through significant structural changes. The main drivers of growth have been retail and wholesale trade and other services, including the financial sector. The migrant's remittances have become one of major source of capital formation. The article examines how the impact of external factors has affected productivity and structure of the agricultural sector in the Republic of Moldova. To capture a comprehensive picture of the rural transformation this study integrates analysis into the different quantitative and qualitative surveys during last ten years. In small transition economies the diagnosis of the structural transformations is based on scarce data and incomplete information. In order to investigate the actual state of agri-food sector were used specific methods and techniques: statistical and economic analysis of macro economic indicators, semi-structured interviews of key stakeholders, analysis of the impact of public policies on the agricultural sector. The main conclusion of this paper is that the agricultural sector has undergone major structural changes, including fragmentation of land, rural depopulation, degradation of irrigation systems, and rapidly changing trade conditions in traditional markets. Public and private policies should exploit innovations and technology transfers, as well as improving professional skills of the labour force employed in agriculture.*

**Key words:** agriculture, agri-food sector, agri-food trade, agricultural policies

### **INTRODUCTION**

Over the past two decades, Moldova's economy has gone through significant structural changes. The service sector has been the largest contributor to the economic growth, while tradable sectors, namely agriculture and manufacturing, have stagnated. Moldova's recent macroeconomic performance has been volatile, reflecting exposure to global economic and climatic risks.

The agricultural sector is characterized by large exposures, which often, but not exclusively, comes from climate phenomena. There are different types of risks faced by agriculture in several European countries, including the Republic of Moldova.

Trade policies promoted by the Republic of Moldova are mostly oriented towards product diversification, knowledge transfer and promotion of new competitive goods with high added value for domestic and foreign markets. The current situation in the

international trade with agri-food products placed the Republic of Moldova in a difficult position [2].

In this context, the paper presents an analysis of agri-food sector and external trade, impact of external factors over the national economy, opportunities for the sustainable development in rural areas and possible solutions to increase resilience to agro-food foreign trade shocks.

### **MATERIALS AND METHODS**

Given the recent challenges to the development of the foreign food trade, the following research methods were used: economic analysis of macro economic indicators, export analysis of main groups of agri-food products, food security analysis, and analysis of the impact of public policies on the agri-food sector.

The main sources of primary information for this paper were used publications and databases of the National Bureau of Statistics

of Moldova, the official site of National Agency for Payments and Interventions (AIPA), Ministry of Agriculture and Food Industry, Ministry of Finance, UN Comtrade data base. As a secondary source of information a number of articles and studies prepared by local and foreign experts were used.

## RESULTS AND DISCUSSIONS

Over the past ten years, Moldova's economy has gone through significant structural changes. The service sector has been the largest contributor to economic growth, and

tradable sectors, namely agriculture and manufacturing, have stagnated.

According to data from 2013 the share of the industry sector in the GDP was of about 14%. The contribution of agriculture was of about 12%, and service sector contributed with about 59%.

The main drivers of growth have been retail and wholesale trade and other services, including the financial sector. The transport and communications sector has also been strong. Agriculture and industry as share of GDP have been on a steady decline, falling from 56 percent in 1995 to about 26 percent in 2013 (see figure 1).

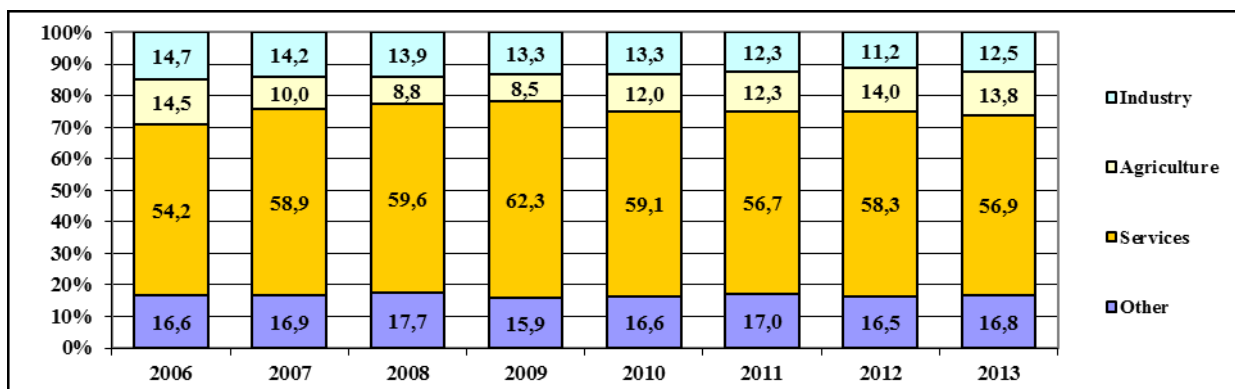

Fig. 3. Structure of the GDP by sectors, 2006-2013, %

Source: National Bureau of Statistics, 2014 [6]

In response to the vulnerabilities inherent in the remittance-driven model, the Government of Moldova has made a committed decision to pursue a strategy of export-oriented economic growth

The national development strategy, Moldova 2020, is centered around the need to transition to a dynamic economic model based on investment and the development of goods- and services-exporting industries. Putting this model in place requires substantial increases in domestic investment and FDI, and enhancing knowledge and innovation, in order to increase efficiency and competitiveness.

### Primary agriculture

Favourable climate and high quality soils historically have determined Moldova's agricultural specialization, particularly in the production of high value crops like fruits and vegetables. Agriculture contributed with almost 12.5% of the country GDP in the year 2013. About 29% of the active population of

the country was engaged in agriculture in the year 2013.

A great part of the Moldovan agricultural sector is composed of two major sub-sectors: corporate sector comprising large companies and the individual sector that includes peasant farms and household land in private property. On the one hand, small farms, especially subsistence and semi-subsistence farms generate a limited surplus of high value-added crops (fruits, nuts, grapes, vegetables, potatoes) that are mostly sold in open air agricultural markets [4].

In the same time large scale agricultural companies are specialized in the production of low value-added crops (such as cereals, oilseeds, sugar beet), and employ limited labour force due to the high level of mechanized agricultural operations. This specialization has been driven by a number of factors such as the relatively low production cost of these crops, the availability of

agricultural machinery allowing the rapid cultivation on large areas, relatively simple and cheap post-harvest facilities, as well as assured markets for these commodities.

General objective of the agri-food sector of the Republic of Moldova is formulated as the following: Increase competitiveness of the agri-food sector through modernization and market integration. Specific objectives are related to: modernization of agri-food chain in order to meet EU requirements on food safety and quality; facilitation the access to capital, inputs and output markets for farmers; reform of education, scientific research and rural extension services in the agri-food sector, and creation of integrated agriculture information system [1].

### Input production

At the national scale just a few companies provide supply services for agricultural farms. The most important one is the Moldagrotehnica SA that offers a large range of ploughs, seeders, cultivators and heavy disc harrows. In recent years, the company established close cooperation with foreign companies such as: Dutch AP MACHINEBOUW, Slovenia - SIP, Germany - WIRGEN and Kijner Import-Export and Italian-MAURA.

Another supplier of agricultural equipment is the Institute of Agricultural Technique Institute (ITA) "Mecagro". The Institute elaborates technical document and policies for the development of mechanized agricultural sector and efficient use of technical means, performs scientific research and technological

designs, and develops technologies and technical means for the agricultural sector, for the production and use of the renewable energy.

### Input use

Moldovan agricultural production is entirely dependent on imported agrochemicals products, seeds and fuel and this has a strong impact on the competitiveness of food products. Primary inputs such as fuel, fertilizer and chemicals for plant protection necessary for agricultural production are all imported. This dependence makes Moldovan agriculture subject to international price volatility.

Insufficient access to high quality inputs remains a constraint for competitiveness in a number of sub-sectors. Manufacturers of high value crops such as fruits and vegetables, which rely mainly on imported seeds and seedlings, appear to be most affected by lengthy and costly procedures for registration of varieties. The test requirements and registration that govern imports of seeds and seedlings are probably the most important constraints and are currently nominated by stakeholders as an obstacle for production of more competitive crop varieties due to the costs involved and delay of access. This is also an obstacle to access to inputs for the agri-food processors.

After a strong decline of mineral fertilizers use during 90s the situation was slightly improved. Thus comparing with the year 2005 the quantity of mineral fertilizers use increased more than twice in 2013 (see table 1).

Table 1. Fertilizers' use in the Republic of Moldova 2006-2013 and its ratio 2013 vs. 2006, thousand tones, %

	2006	2007	2008	2009	2010	2011	2012	2013	2013/2006, %
Pure nutrients use. total	15.4	20.1	22.7	17.0	20.1	23.6	34.7	44.8	290.9
<i>N. total</i>	12.8	17.1	19.9	14.6	16.4	19.2	26.9	34.0	265.6
<i>P<sub>2</sub>O<sub>5</sub>. total</i>	1.9	2.0	1.7	1.6	2.4	2.9	5.6	8.3	436.8
<i>K<sub>2</sub>O. total</i>	0.7	1.0	1.1	0.8	1.3	1.5	2.2	2.5	357.1

Source: Statistical Yearbook of the Republic of Moldova. 2014 [6]

However level of agricultural land fertilization is much lower comparing with EU and other neighbouring countries. Utilization of organic fertilizers demonstrates the same tendencies.

### Food industry

Lack of horizontal and vertical coordination

of supply chains is another reason underlying the low competitiveness of the agricultural sector. The reasons causing nowadays the low prices for products include poor development of wholesale markets, low power of negotiation, changing product quality, lack of

distribution channels, poor infrastructure and limited access to foreign markets. Value chain deficiencies lead to large discrepancies between farm gate price and the consumer, resulting in low-income, low investment and persistent low quality at the farm level.

The decline in the food industry is another

key factor underlying the low competitiveness of the agri-food sector. The share of food and processed beverages accounts for about 43% of the total industrial production in the Republic of Moldova, although this share was of 52% in 2004.

Table 2. Value added in agriculture and selected food industries, 2007-2012, millions MDL

Code		2007	2008	2009	2010	2011	2012	2013
A, B	Agriculture, hunting, silviculture and pisciculture	5,333.9	5,544.0	5,134.5	8,657.4	10,095.2	9,896.2	12,383.1
D15	Manufacture of food products and beverages	2,381.5	2,768.8	2,516.0	3,086.0	3,682.9	3,974.3	4,315.3
D15.1	Production, processing and preserving of meat and meat products	240.1	293.2	273.8	300.5	393.1	472.0	505.0
D15.3	Processing and preserving of fruits and vegetables	259.5	226.4	201.9	245.1	427.4	370.3	420.2
D15.5	Manufacture of dairy products	227.5	269.0	303.0	344.4	380.9	429.9	481.8

Sources: National Bureau of Statistics of the Republic of Moldova, 2014 [6]

Prices and production costs for the most important processed food products are not presented in the official statistics of the Republic of Moldova. The available generalized data from national accounts confirm the conclusion that agri-food sector produces mostly raw material and semi-processed products.

The ratio between the value added in agriculture and processing industry shows that during the recent years the value added in agriculture is higher than those created in the food processing industry more than of 2.4 times on average for the period of 2007-2012 (see figure 2).

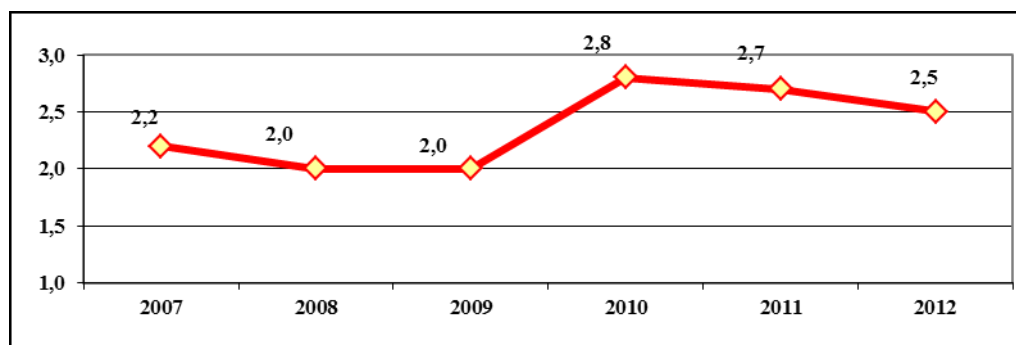

Fig. 4. Ratio between the value added in agriculture and processing industry, 2007-2012

Sources: elaborated by authors based on data from National Accounts of the National Bureau of Statistics, 2014 [6]

At the same time food processing industry has a higher productivity comparing with the agricultural production.

### Consumption

At the national level Republic of Moldova is food secure. It produces its main food products, exports its surplus food, and imports what it needs to meet its food requirements.

Food security indicators prove that in the Republic of Moldova the level of per capita food consumption have stabilized during the

last years. However there are some evident changes in consumption patterns. Thus in the period of 2006-2013 the consumption of cereals and bread products has been steadily reduced by about 20%. Consumption of potatoes and vegetables has been reduce even more significantly with about 40% and 35 % respectively. In the same time consumption of grapes increased twice, while consumption of meat increased with about 21% (see table 3).

Table 3. Human consumption per capita and its variation 2013 vs. 2006, 2006-2013, kg, %,

	2006	2007	2008	2009	2010	2011	2012	2013	2013/2006, %
<b>Cereals</b>	173.5	146.7	160	152	152.4	148.6	141.0	137.4	79.2
<b>Sunflower</b>	1.6	0.7	0.7	0.7	0.8	0.8	1.0	1.5	93.8
<b>Potatoes</b>	87.6	58.8	58.0	59.3	56.7	59.8	52.3	52.7	60.2
<b>Vegetables</b>	131.9	75.8	99.1	106.3	109.6	114.6	78.2	85.9	65.1
<b>Fruits</b>	35.8	24.1	36.7	30.5	34.3	34.6	34.3	35.1	98.0
<b>Grapes</b>	3.0	3.8	4.4	4.1	6.4	8.1	6.4	6.4	213.3
<b>Meat</b>	38.3	36.0	32.3	29.5	35.6	37.9	39.7	46.2	120.6
<b>Eggs</b>	167.5	177.1	141.1	161.7	184.9	189.6	155.7	165.0	98.5
<b>Milk and milk products</b>	177.3	175.4	155.0	168.9	175.3	170.2	170.8	166.0	93.6

Sources: National Bureau of Statistics of the Republic of Moldova, 2014 [7]

Another aspect of the consumption patterns is reflected by the level of daily calorie intake that shows an increasing trend since 2008 after a decline during the period of 2006-

2007. There are also some other interesting trends that show a proximation of daily calorie intakes in rural and urban areas (see figure 3).

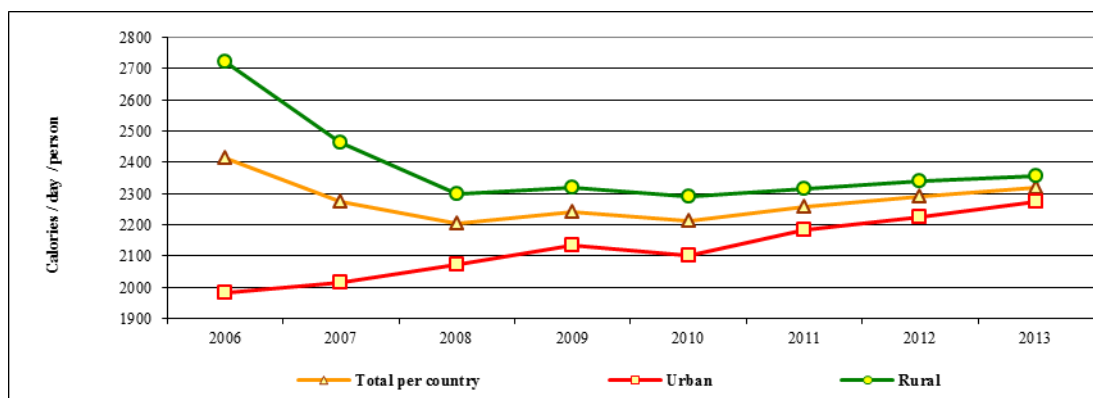

Fig. 5. Average calorie intake in the Republic of Moldova in rural and urban areas, calories / day / person, 2006-2013

Source: National Bureau of Statistics of the Republic of Moldova, 2014 [7]

The nowadays food security challenges in the Republic of Moldova have two major dimensions. The first dimension seeks to maintain and increase the country's ability to face the national food demands through assurance of the internal food production, import of the food products that can not be produced efficiently in the country, and exports of products that have a comparative advantage.

The second dimension is related to the reduction of the increasing inequalities and expansion of the poverty among the majority of the households of the Republic of Moldova that is manifested by inadequate and unstable food supplies, lack of purchasing power, weak institutional support networks, weak food emergency management systems and unemployment.

In addition to natural risks, commercial risks largely influence the level of food security in

the Republic of Moldova. The evolution of prices in Moldova follows the trends of international food prices, agricultural products and resources for agricultural production in relative terms. Like other small countries with low income, Republic of Moldova faces additional challenges when making an effort to refocus and modernize the sector of primary production and processing industry in order to supply the local market with basic food products.

The level of food self-sufficiency of the country is rather high, however in several years it decreases to a critical degree due to severe droughts (see table 4).

#### Agri food export

The Republic of Moldova is part of a range of foreign trade agreements that creates opportunities for commercial relations with 93 countries. The main trade partners for export of major groups of agri-food products are

Russia, Ukraine, Belarus, Romania, Italy, France and Spain. The evolution of agri-food exports during the last years has a stable increasing trend. However, the recent

sanctions imposed by the Russian authorities could affect negatively country's agri-food export, economic stability and food security.

Table 4. Self-sufficiency rate (%), 2006-2012

	2006	2007	2008	2009	2010	2011	2012	2013
<b>Cereals</b>	99.2	70.6	143.4	105.0	117.8	115.6	60.8	150.3
<b>Sunflower</b>	145.0	65.5	178.0	121.4	156.6	195.9	143.8	326.3
<b>Potatoes</b>	91.7	67.0	93.4	89.4	100.4	116.2	66.6	89.8
<b>Vegetables</b>	103.5	84.8	110.1	98.6	104.2	100.5	93.3	102.4
<b>Fruits</b>	195.8	227.0	222.2	213.9	207.7	237.7	245.2	264.2
<b>Grapes</b>	102.4	106.8	102.6	104.3	104.6	102.8	103.9	103.7
<b>Meat</b>	67.8	84.5	67.8	86.7	86.0	86.1	81.5	69.8
<b>Eggs</b>	112.7	101.6	100.0	100.3	98.8	95.4	102.2	98.0
<b>Milk and milk products</b>	97.5	95.0	97.1	95.0	94.1	92.0	84.7	86.8

Sources: National Bureau of Statistics of the Republic of Moldova, 2014 [7]

The state policy in the sphere of foreign trade is carried out through the customs tariff (the application of import tariffs) and non-tariff regulation (in particular, through quotas and licensing), also through the introduction of special duties (special, antidumping and countervailing) for foreign trade activity in accordance with the legal framework and international treaties, signed by the Republic of Moldova.

The state is ensuring that installed protective measures, restrictions and prohibitions in the

field of foreign trade activities correspond to the reasons behind the need for their introduction. The preference is given to those protective measures, restrictions and prohibitions that cause minimal damage to the implementation of this action and do not contravene to international standards.

The most important export groups of products for Moldova agricultural sector are "Edible fruits and nuts", "Alcoholic and non-alcoholic beverages", "Oil seeds" and "Vegetable oil" (see figure 4).

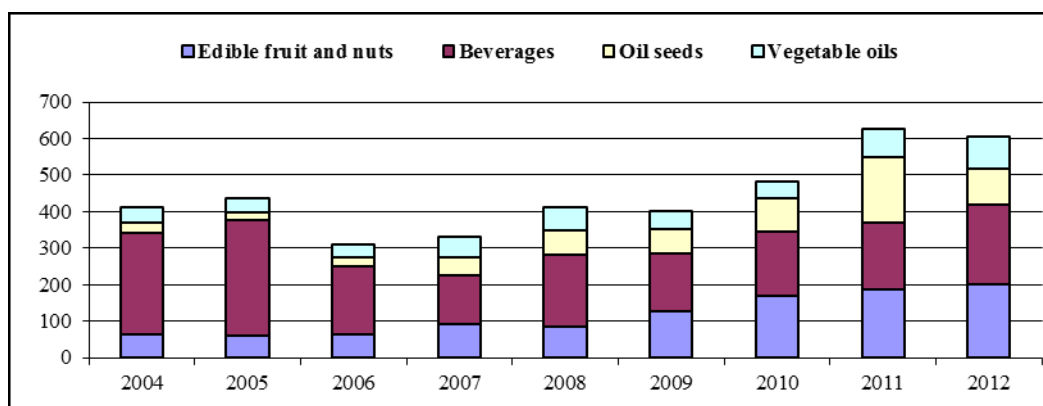

Fig. 6. Most important exported products in the Republic of Moldova 2004-2012, millions USD  
 Sources: National Bureau of Statistics, 2014 [7]

The main export destination countries for these groups of products are Russia, Ukraine, Belarus, Romania, Italy, France and Spain. Out of these four major groups of products only two, namely "Oil seeds" and "Vegetable oil" were not included in the restriction list imposed by Russian authorities. While external trade with other two groups of products was seriously affected by these

restrictions. This leads to the question to what extent these restrictions threaten the stability of the Moldovan economy. Despite a drop in exports to Russia by almost one quarter during the first half of the year 2014 (compared to the same period of the year 2013), total Moldovan exports grew by 3% over the same period. Among the most important categories of



imported food products one can mention tobacco, alcoholic drinks, meat, fish and dairy products.

The agri-food exports from the Republic of Moldova to Russian Federation in the period 2013-2014 were marked by a continuous decreasing trend, ending in the October 2014 with a total embargo for the export of such food categories as “02 Meat”, “04 Dairy products”, “07 Vegetables” and “08 Fruits” (see table 5).

Among the most important groups of agri-food products exported from the Republic of Moldova to Russian Federation in 2013-2014 are “08 Fruits” and “07 Vegetables”, followed by “02 Meat” and “04 Dairy products”. A specific particularity of the Moldovan agri-food exports to Russian Federation is the irregular character of deliveries that cannot be explained only by seasonality of the agri-food production.

Table 5. Volume of monthly exports to Russia at two-digit level (in tons), annual and monthly variation (in %)

	02 Meat	04 Dairy	07 Vegetables	08 Fruits
July 2013 (tons)	151.11	140.00	900.83	12,461.18
August 2013 (tons)	259.54	112.02	22.08	31,560.20
September 2013 (tons)	360.10	115.93	107.42	37,159.01
October 2013 (tons)	538.95	60.00	66.61	48,787.05
July 2014 (tons)	466.25	180.00	439.98	7,585.70
August 2014 (tons)	88.85	0.00	245.46	2,866.87
September 2014 (tons)	101.12	20.00	199.15	3,692.31
October 2014 (tons)	0.00	0.00	0.00	0.00
Annual variation August 2013/14	2.92	-	0.09	11.01
Annual variation September 2013/14	3.56	5.80	0.54	10.06
Annual variation October 2013/14	-	-	-	-
Monthly variation July/Aug 2014	5.25	-	1.79	2.65
Monthly variation August/Sept 2014	0.88	0.00	1.23	0.78
Monthly variation Sept /Oct 2014	-	-	-	-

Source: own calculations based on UN Comtrade data base (<http://comtrade.un.org/data/>) [8]

Export of the meat to Russia is irregular and covers mainly chilled and frozen beef. The meat exports to Russian Federation were completely stopped in October 2014 as a result of the non-tariff protection measures.

The meat export is insignificant amounting to an average value of about 300 tons per month. The predominant kind of exported meat is beef chilled or frozen. Considering that the Republic of Moldova is a net importer of meat and the quantity of the meat exported to Russia is insignificant it can be concluded that restrictions on meat export to Russia will not affect significantly the trade between two countries.

The production of vegetables in the Republic of Moldova ensures mainly the internal needs of the country. Export potential of vegetable products is rather insignificant. The self-sufficiency rate for vegetable production varied from 103.5% in 2006 to 93.3% in 2012. The deficit of vegetables mainly in the out of season period is covered by imports

from Turkey. Export of vegetables to Russia is irregular and covers mainly potatoes and tomatoes. The volumes of vegetables exported to Russia are not important and their share in total Russian imports of vegetables is insignificant. Some efforts these exports could be shifted to other destination points.

The fruit production in the Republic of Moldova is very important not only for the internal needs of the country but it also offers large opportunities for fruit exports. Export potential of the fruit production is very high. The self-sufficiency rate for fruit production varied from 195.8% in 2006 to 245.2% in 2012. The surplus of fruits was exported mostly to Russian Federation. Export of fruits to Russia are covered mainly by “0808 - Apples, pears and quinces”, “0809 - Apricots, cherries, peaches incl. nectarines, plums and sloes” and “0806 - Grapes”. Russian federation was a main market for Moldovan fruit exports. Non-tariff restrictions imposed by Russian authorities affected severely this

sector with negative economic and social impacts.

**Main agricultural policy instruments and measures**

In 2009-2013, the government mobilized from the state budget with the support of donors a value of approx. 2.2 billion lei for support of the agricultural production. The most important ten areas of agricultural production were selected for subsidization and namely: a) Stimulation of agricultural credits, b) Stimulation of the risk insurance in agriculture, c) Establishment of perennial plantations, d) Vegetable production on protected land, e) Procurement of equipment for agriculture, f) Procurement of equipment and renovation of livestock farms, g) Purchase of high breed animals, h) Development of

post-harvest infrastructure, i) Land consolidation, j) Farmland irrigation.

The total amount of subsidies allocated to the agricultural sector increased in 2013 to 462.5 millions MDL comparing with 400 millions MDL in the period of 2010-2012. However, despite of this slight increase the share of agricultural subsidies in national GDP is decreasing constantly since 2009 to the level of 0.46%

One can mention that this value is much lower than in neighbouring countries.

Direct producer support measures in the RM are rather limited and refers to only three items, namely: a) support for purchase of pedigree livestock, b) stimulation of the risk insurance in agriculture and c) stimulation of the agricultural irrigation (see table 6).

Table 6. Direct producer support measures (millions MDL), 2004-2013

Support measure	2006	2007	2008	2009	2010	2011	2012	2013
Support for purchase of pedigree livestock	1.0	3.5	3.2	3.4	4.8	4.7	8.1	23.4
Stimulation of the risk insurance mechanism in agriculture	2.7	16.3	27.2	25.5	9.9	-	34.9	41.3
Stimulating agricultural irrigation	NA	NA	13.0	10.0	9.3	2.0	NA	2.1

Sources: National Agency for Payments and Interventions in Agriculture, 2014

On farm restructuring support measures covers five specific areas like: a) subsidizing investment in establishment of perennial plantations, b) investment subsidies for vegetable production on protected land, c)

stimulation of investments and purchase of machinery and equipment, d) stimulating investment in equipment and technological renovation of livestock farms, and e) interest rate subsidy for long-term loans (see table 7).

Table 7. On farm restructuring support measures, (millions MDL), 2004-2013

Support measure	2006	2007	2008	2009	2010	2011	2012	2013
Subsidizing investment in establishment of perennial plantations	23.6	26.1	47.1	76.1	52.0	41.4	37.4	88.7
Investment subsidies for vegetable production on protected land (winter greenhouses, greenhouses, tunnels)	NA	NA	5.6	2.5	4.0	6.2	6.1	14.5
Stimulation of investments and purchase of machinery and equipment	NA	5.0	38.6	40.8	46.7	97.0	103.2	141.2
Stimulating investment in equipment and technological renovation of livestock farms	14.0	14.8	23.0	22.5	2.8	12.0	7.8	27.3
Interest rate subsidy for long-term loans	-	-	-	-	-	3.3	25.3	39.3

Sources: National Agency for Payments and Interventions in Agriculture, 2014

Even more insignificant are some other types of support measures like: supporting the promotion and development of the organic agriculture and stimulating investment in development of post-harvest and processing infrastructure (see table 8).

**Budgetary and other transfers to agriculture**

Adjustment of the agribusiness sector of the

Republic of Moldova to EU requirements and standards harmonization is not only legislative but also requires considerable efforts related to the actual implementation of technical standards, security, technology, standards, management and control systems (HACCP, GAP, ISO ), which requires considerable financial resources.



Table 8. Other type of support measures, (millions MDL), 2004-2013

Support measure	2008	2009	2010	2011	2012	2013
Supporting the promotion and development of the organic agriculture	2.0	4.0	2.2	0.8	NA	NA
Stimulating investment in development of post-harvest and processing infrastructure	7.0	15.0	11.3	27.9	20.0	69.8

Source: National Agency for Payments and Interventions in Agriculture, 2014

In this context, the greatest challenge for MAFI is to synchronize actions and apply the tools of financial support (including national budget, sources from donors, EU support) to achieve the major objectives of the sector: increasing competitiveness, modernization and restructuring, as well as support for rural development.

The total value of the State budget expenditures for the sector of agriculture,

forestry and pisciculture has an increase up to MDL 1,386 millions in 2013 after a decrease from MDL 1034 millions in 2009 to MDL 697 millions in 2011. The most important allocation goes to the group 11.01 Agriculture and 11.05 Activities and services in the field of agriculture, forest management, fish farms and household water unassigned to other groups (see table 9).

Table 9. State budget expenditures for the sector of agriculture, forestry and pisciculture, (thousands MDL), 2009-2013

	2009	2010	2011	2012	2013
11 Agriculture, forestry, fishing and water management	1,034,123	857,734	843,463	1,272,735	1,386,298
11.01 Agriculture	792,518	616,735	603,42	697,994	719,549
11.02 Forestry	28,897	9,624	10,518	7,165	11,984
11.03 Pisciculture	0	0	0	20	0
11.04 Water Management	19,463	15,973	19,703	17,101	13,201
11.05 Activities and services in the field of agriculture, forest management, fish farms and household water unassigned to other groups	170,847	193,592	184,928	519,102	607,700
11.10 Administrative Organs	22,398	21,811	25,072	31,353	33,863
<b>General total</b>	<b>1,034,123</b>	<b>857,734</b>	<b>843,463</b>	<b>1,272,735</b>	<b>1,386,298</b>

Sources: Ministry of Finances, 2014 [3]

The share of the Fund of subsidies for agricultural production in the total value of the State budget expenditures for the sector of agriculture, forestry and pisciculture has a decreasing trend from 54.1% in 2009 to 33.4% in 2013 (see figure 5).

The negative tendency the share of expenditures for agriculture in the countries'

GDP can be clearly followed in the period 2009-2013. The share of subsidies for agricultural production decreased almost twice from 0.9% of GDP in 2009 to 0.5% in 2013, while the share of state budget expenditures for agriculture, forestry and fishery in the GDP had a more moderate decrease from 1.7% in 2009 to 1.4% in 2013.

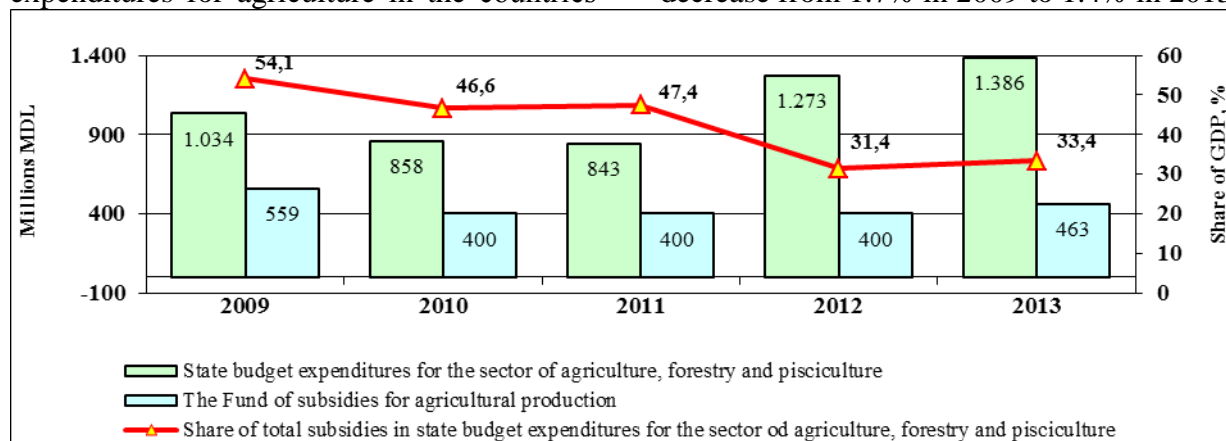

Fig. 7. The total value of State budget expenditures for the sector of agriculture, forestry and pisciculture, the Fund of subsidies for agricultural production and the share of total subsidies in the State budget expenditures for the sector of agriculture, forestry and pisciculture, 2009-2013, MDL millions, %

Source: own calculation based on data from National Bureau of Statistics and AIPA, 2014 [5, 6]

## CONCLUSIONS

The critical situation of the agriculture within the rural transformation and national economy context with its structural features requires substantial governmental and financial interventions oriented at the reduction of natural risks that could affect the rural communities, as well as at generating necessary savings and investments in agriculture.

Maintaining the production capacity of agricultural land is a strategic national security concern. Therefore is important to implement modern efficient technologies in agriculture in order to increase soil fertility, ensure food security and strengthen the resilience of the agri-food sector toward external shocks.

The agro-food sector in the Republic of Moldova is characterized by weak links between primary agricultural production, processing industry and trade sector, underutilization of the production capacities, lack of investments, outdated equipment and standards.

There are positive trends in the development of the agri-food sector of the Republic of Moldova during the last years. However the vulnerability of this sector to natural, economic and commercial risks remains to be very high.

The current situation in the international trade with agri-food products placed the Republic of Moldova in a difficult position. Exchange of sanctions between a number of Western countries and the Russian Federation provides multiple restrictions on the conduct of economic activities, including international trade that makes it necessary to review existing economic policies.

The volume of subsidies for agricultural production is insufficient and can affect negatively the country's resilience to external shocks.

Prohibitions and restrictions on the part of the Russian Federation on the import of agricultural products from the Republic of Moldova are forcing the government to urgently diversify export markets and to take

measures to strengthen the economic security of the country.

The food sector of the Republic of Moldova needs specific actions in order to stimulate development of the high value agriculture through creation of product sales centres, strengthening quality control, organizing regional wholesale markets, assisting producers to sell their products, development of market infrastructure at central level, development of the post harvest and market infrastructure.

## ACKNOWLEDGMENTS

The authors wish to express their appreciation to the FP7 project "AGRICISTRAD" team for their efforts, and valuable inputs and comments.

## REFERENCES

- [1]Government of Moldova, 2014, National strategy on agriculture and rural development for the period 2014-2020. Approved by the Government Decision no. 409 from June 4, 2014
- [2]Ministry of Agriculture and Food Industry. Official web site: <http://www.maia.gov.md/>
- [3]Ministry of Finance. Official web site: <http://www.mf.gov.md/>
- [4]Moroz, V., Ignat, A., Lucasenco, E., 2014, Small and large farms in the Republic of Moldova: Trends and Perspectives. In: Management Theory and Studies for Rural Business and Infrastructure Development, Vol. 36. No. 4:902-912, 2014
- [5]National Agency for Payments and Interventions in Agriculture, 2014, Official web site: <http://aipa.md/>
- [6]National Bureau of Statistics, 2014, Statistical yearbook of the Republic of Moldova, Chisinau
- [7]National Bureau of Statistics, 2014, Statbank database. Official web site. Access: <http://www.statistica.md/>
- [8]UN Comtrade data base. Accessed: <http://comtrade.un.org/data>

## STUDY ON THE INFLUENCE OF SEVERAL FACTORS ON THE RESULTS OF USING THE MEAT CHICKEN RAISING TECHNOLOGIES

Ioana NICULAE, Georgiana Melania COSTAICHE

University of Agricultural Sciences and Veterinary Medicine Bucharest, 59 Marasti, District 1, 11464, Bucharest, Romania, Phone: +40213182564, Fax:+40213182888, Mobile:+40744 6474 10, Emails: iniculae2006@yahoo.fr, melania.sanda@yahoo.com

*Corresponding author:* melania.sanda@yahoo.com

### Abstract

*The activity of the enterprises for raising chickens for meat must have a profit that, in a market economy, will ensure the restart of production processes. Therefore, the meat chicken raising technologies have to be designed and applied so that they lead to the achievement of profitable production. The production process performed in view of raising meat chicken is a result of the interaction of several factors. Knowing these factors and the way in which they affect production and costs represents the key premises for preparing the meat chicken raising technologies. The aim of this paper is to show the impact of several technological and economic factors on the financial result obtained following the use of that technology. The analysed factors are: daily average growth, specific consumption, production cost and sales price. The results of the study indicated that the financial result of Dulbanu No 1 farm, Amaru commune, Buzău County has been insignificantly affected by the daily average growth and specific consumption and very significantly by the production cost and sales price.*

**Key words:** correlation, daily average growth, profit,

### INTRODUCTION

As regards the activity of an economic operator, the economic growth process is highly complex and because of that, it has to take into account the involvement of the information technology factor and a large interdisciplinary study.

The innovation driven technological progress has many effects. It contributes to the improvement of the production systems by increasing labour productivity, causes economies by diminishing the average costs per product unit, limits and diminishes the environmental and social costs by eliminating and controlling the pollution sources. [4]

Any activity targeting the creating of products implies a certain micro-economic framework, capital goods and means to use them, elements prefiguring the content of a technology. The content of a technology reflects the capital goods, the level of knowledge existent a certain moment in time and the way in which the connection of the factors involved in the performance of the technology is obtained. [2]

In general, a technology represents the entire

methods, procedures and processes used in order to obtain a product.

The technology may be defined as being a complex aggregate of knowledge, means and abilities, created in order to obtain a certain product. [4]

In case of agricultural production, the technology bears the mark of this branch of activity in which plants and animals are living organisms with their own necessities regarding growth and development and which undergo a series of changes regarding the shape and sizes. [8]

The Zootechnical Encyclopaedic Dictionary defines the animal farming technology as the science of optimizing, organizing and managing the technological processing with the aim of maximizing the productions and incomes.

The animal raising technology may be defines as a set of processes, methods and technical and organizational measures that are performed in a certain sequence and that are aimed at the meeting of animal needs and offer the possibility of obtaining a high output in economic efficiency conditions. [7]

The farming technology represents a set of

processes, methods, procedures and operations that used during the technological flow offer the possibility to obtain maximal animal production. [5]

Any production technology is performed under the influence of a set of factors. Knowing these factors and the way in which they affect the production and costs represents the key premises necessary in preparing a technology.

The biological material used that is influenced by the heredity factors [9], the raising and feeding methods, the ensuring of micro-climate conditions, the using of preventive sanitary and veterinary measures represent elements of intervention at technical and technological level, but which influence differently the quantity, quality and production cost. [6]

Based on it, the transition from knowledge to action can be performed with the aim of using in a more efficient and proper way the results of investigations, emphasizing the dependency between the production and factors that determine its volume, quality and cost.

The aim of this paper is to show the impact of several technological factors on the financial result obtained following the use of that technology for raising meat chicken.

## MATERIALS AND METHODS

The research was based on the results of using the meat chicken raising technology in Dulbanu No. 1 farm, Amaru commune, Buzău County.

This farm belongs to S.C. VOX AGRI S.R.L., Urziceni Municipality, Ialomița County. The basic activity of this farm is raising meat chicken. It has a capacity of 360,000 chicken/day/series for stocking and approximately 1,940,000 of 42 days old chickens weighting 2.78 kg/head.

Dulbanu No. 1 farm of the Meat chicken raising complex belonging to S.C. VOX AGRI SRL has 9 halls and other related buildings, with a capacity of 40,000 animals/hall.

The farm uses free-range farming technology for raising chickens and during the analysed

period has used as biological material the Ross-308 hybrid, a hybrid with special performances.

In order to analyse the results of the farm and to determine the influence of some factors on the results obtained as a result of using the farming technology, the following were used as methods: comparison, index method, correlation method and regression method.

The correlation method is a modern statistical and mathematical method which allows the quantification of the intensity of the relation between one of several factors and an analysed phenomenon between which there are stochastic relations.[3]

This method represents a modern tool which guarantees not only the accuracy of formulating the analysis conclusions, but also the efficiency of the decisions to be taken on this basis, in the real economic activity.

The regression method offers the possibility that, through the regression function, to analyse the way in which the dependent variable behaves in average under the influence of one or several independent variables if all the other variables-cause would have a constant or non-essential influence.

## RESULTS AND DISCUSSIONS

Dulbanu No. 1 Farm had a profitable activity during the analysed period, 2011-2013. In each of the three analysed period profit was obtained, the effects being superior to the efforts made (Table 1.).

The incomes have had the following trend: in 2012, they have decreased compared to 2011, with 19%, and in 2013, they have increased with 12% compared to 2011 and with 38% compared of 2012. The increase is due to the fact that in this year, the results expresses through the technical indicators were superior to those belonging to the other two years.

The expenses were lower than the incomes, which allows for a profit to be obtained. It can be noted that the expense increase ratio is lower than the income increase ratio.

The expense efficiency level is reflected by the rate of return. In 2011, it was of 13.9%, in 2012 has decreased to 17.3% compared to

2011. In 2013, the rate of return has increased with 16.5% compared to 2011 and with 40.9% compared to 2012.

Being a farm that uses the intensive, industrial system for the raising of meat chicken, the level of economic efficiency is also given by the labour productivity expressed as the level of profit per m<sup>2</sup> of premises. It was of Lei 84.4/m<sup>2</sup> in 2011, then had decreased to Lei 57.7/m<sup>2</sup> in 2012, the decrease being of 32% compared to 2011 and then has increased to Lei 107.7/m<sup>2</sup> in 2013. The increase was of 27.6% compared to 2011 and with 87.3% compared to 2012.

The results of applying the technology within the farm are analysed below based of effort indicators, effect indicators and efficiency indicators.

Table 1. Financial results obtained by Dulbanu No. 1 Farm of S.C. VOX AGRI S.R.L. in the period 2011-2013

Specification	U.M	Year		
		2011	2012	2013
Incomes	Thou lei	21,056.4	17,052.2	23,562.2
Expenses	Thou lei	18,479.5	15,290.4	20,274.3
Profit	Thou lei	2,577.1	1,761.8	3,287.9
Rate of return	%	13.9	11.5	16.2
Labor productivity	Lei/m <sup>2</sup>	84.4	57.7	107.7

Source: Farm records

Dulbanu No. 1 Farm that uses the technology of rearing mat chicken on permanent litter has a designed capacity of 360,000 per series, with a density of 12 heads/m<sup>2</sup> according to the European regulation on poultry welfare and an annual nominal capacity of 1,980,000 heads resulted from 5.5 series.

The technical effort employed for the enforcement of the technology can be expressed with the help of the following indicators: number of chicken in stocking and stocking density.(table 2)

The number of chicken entered into stocking in 2011 was with 7.7% higher than the annual nominal capacity of the farm as a result of the fact that six series have been realized. The six series was accomplished by reducing the following.

In the following year, the number of chicken

in stocking was with 9.3% smaller than the annual nominal capacity as a result of the fact that only five series have been accomplished. In 2013, a number of chickens with 4.2% higher than the technological rated capacity has entered into stocking. As in the first year, this year six series has been accomplished.

By comparing the actual stocking density with that estimated by the technology (12 heads/m<sup>2</sup>), minor negative differences are noticed. Thus, compared to the technological density of 12 heads/m<sup>2</sup>, in 2011, the average stocking density was of 11.6 heads, with 3.3 % lower than the estimated density. In 2012, the stocking density was of 11.7%, i.e. 97.5% of the estimated one, and in 2013, the actual density was with 5.8% lower than the estimated one.

Table 2. Indicators characterizing the meat chicken raising technology used in Dulbanu No. 1 Farm of S.C. VOX AGRI S.R.L. during the period 2011-2013

Specification	U.M	Year		
		2011	2012	2013
Number of chicken entered into stocking	Head	2,132,454	1,796,624	2,062,706
Stocking density	head/m <sup>2</sup>	11.6	11.7	11.3
Mortality	%	3.48	3.45	3.27
Delivered chicken	Head	2,058,515	1,734,793	1,995,223
Age of slaughter	Days	49.9	49.1	51.5
Daily average growth	G	40.4	37.6	40.5
Specific consumption	kg fodder/kg of growth.	1.82	1.83	1.69
Chicken on delivery and	kg/head	2.11	1.89	2.13
Quantity of meat delivered per m <sup>2</sup>	Kg	23.2	21.6	23.7

Source: Farm records

The effects of applying the technology for raising meat chicken are reflected with the following indicators: mortality percentage, delivered chicken and age of slaughter.

The meat chicken raising technology being an intensive technology it is influenced by the technological risk expressed as mortalities and that affects in a large extent the technical and economic results of the technology.

By the designed technology, the level of mortalities should be of 2% according to the performances of the hybrid.

The effects of the technology applied were the mortalities according to the mortalities specified in the table.

The registered mortality percentages were with 74% higher in 2011, with 72.5% in 2012 and with 63.5%. This actual mortality levels are mainly due to the diseases that may frequency occur in the start-up period.

The number of chicken delivered estimated by this technology takes into account the technological nominal capacity minus the admitted mortalities, resulting 1,940,000 heads/year/farm.

The number of delivered chicken was higher than the level estimated for 2011 and 2013, being with 6% higher the technological one in 2011 and with 2.8% higher in 2013.

In 2012, the number of delivered chicken was with 10.6% lower than the one estimated by the designed technology.

The levels registered for this indicator were due mainly to the number of series, six compared to 5.5 specified by the technology.

The registered age of slaughter was much higher than the one specified by the technology (42 days). The age of slaughter of the chicken was exceeded with 19% in 2011, with 17% in 2012 and with 22.6% in 2013.

The age of slaughter has to be correlated only with the average weight on slaughtering, and not with the delivery pace.

The extension of the age of slaughter results in the increase of the specific consumption. The decrease of the age of slaughter may be obtained by changing the daily average growth, biological material and the fodder recipe.

The following indicators of the technical efficiency of the meat chicken raising technology may be taken into account: daily average growth, specific consumption, average weight of the chicken on delivery and the quantity of meat delivered per m<sup>2</sup> of premises.

The actual daily average growth was below the estimated level in all the three analysed years. The estimated daily average growth was of 57.9 g according to the hybrid

performances.

The deviations from the estimated technology was of minus 30.2% in 2011, minus 35.1% and minus 30.1% in 2013, the level of this indicator showing the conjugated effect of the action of all the factors influencing the production technology.

The level of efficiency of raising meat chicken is finally influenced by the specific consumption, meaning the quantity of fodder necessary for obtaining one kg of weight gain. The estimated specific consumption for the farm was of 1.72 kg combined fodder/kg of growth.

The actual specific consumption was higher in the first two years and under the estimated level in 2013. In 2011, the specific consumption was 5.8% higher than the estimated consumption, and in 2012, it was 6.4% higher. In 2013, the specific consumption was 1.8% lower.

Another factor that can contribute to the increase of the efficiency of meat chicken raising technology is the average weight of the chicken at the delivery. By the designed technology, the average weight was of 2.47%. The results were below the estimated level with 15% in 2011, 23.5% in 2012 and with 13.8% in 2013.

The average weight at delivery is directly influenced by the daily average growth and the duration of fattening period.

In order to obtain an average weight on delivery in economic efficiency conditions, it is necessary to accomplish an as high as possible daily average growth in an as short as possible period.

The technical efficiency of the meat chicken raising technology may be estimated also by the quantity of meat delivered per m<sup>2</sup> of premises indicator. The designed technology estimates this indicator at 29 kg/m<sup>2</sup> of premises.

The applied technology resulted in lower quantities than the ones estimated, representing 80% of these in 2011, 74.5% in 2012 and 81.7% in 2013.

The quantity of meat delivered per m<sup>2</sup> of premises is directly correlated with the stoking density, specific consumption, daily average growth, age of slaughter, mortalities.

In order to reach deep in the content of production technology and to emphasize more the influence of various factors that in the annual profile may be diminished or blurred, the study has to be detailed for each series of chicken.

Dulbanu No. 1 Farm, that applied the meat chicken raising technologies, obtained 17 series in the analysed period. In 2011, six series was obtained, in 2012, five series and in 2013, six series.

The meat chicken raising technology is influenced by different factors, some of them exogenous type, and other of endogenous type.

The results of using the meat chicken raising technology are also influenced by a large number of factors.

The extremely high variability of the technological factors was analysed based on the analysis of variance method.

The indicator, the number of chicken in stocking, has registered an average value of 352,458 heads compared to 360,000 heads, the capacity estimated by the designed technology, deviating from the average with 14,616 heads.

The variation coefficient was of 4.15, representing a low variability of the number of chicken entering the stocking and a satisfactory average (Fig 1).

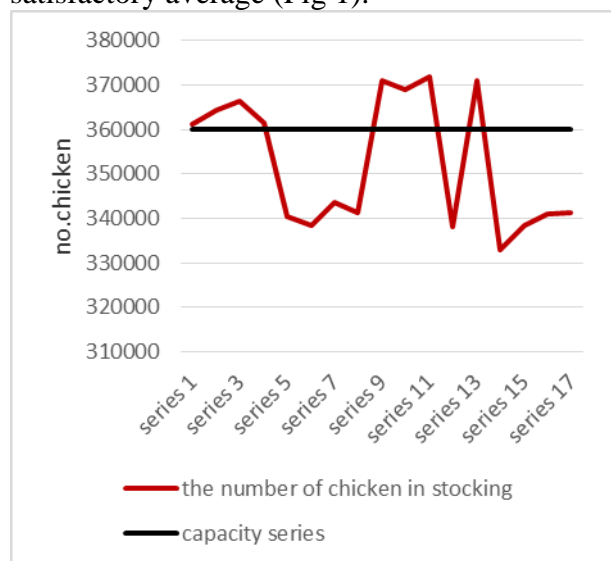

Fig. 1. Evolution of number of chicken entering the stocking per series

The stoking density for the 17 accomplished series has registered an average value of 11.5

chickens/m<sup>2</sup>, with a deviation from the average of 0.5 and a variation coefficient of 4.15, representing a low variability.

The mortalities have registered in general an average value of 3.4%, with a deviation from the average of 0.37% and a variation coefficient of 10.83 %, indicating a quite high variability.

The number of delivered chicken was in average of 340,502 heads for the 17 analysed series, deviation with 14,669 from the average.

The registered variability coefficient was of 4.31%, indicating a low variability (Fig 2).

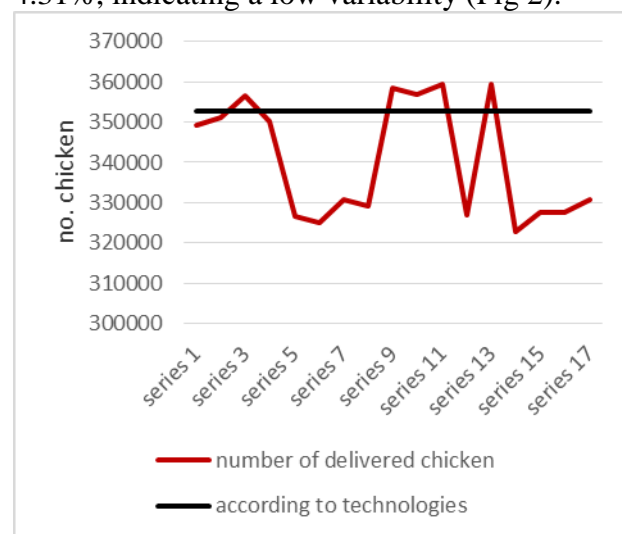

Fig.2. Evolution of the number of chicken delivered per series

The specific consumption is characterized by a low variability of 7.85%, an average of 1.78 kg of fodder/kg of gain with a deviation from the average of 0.14 kg (Fig. 3).

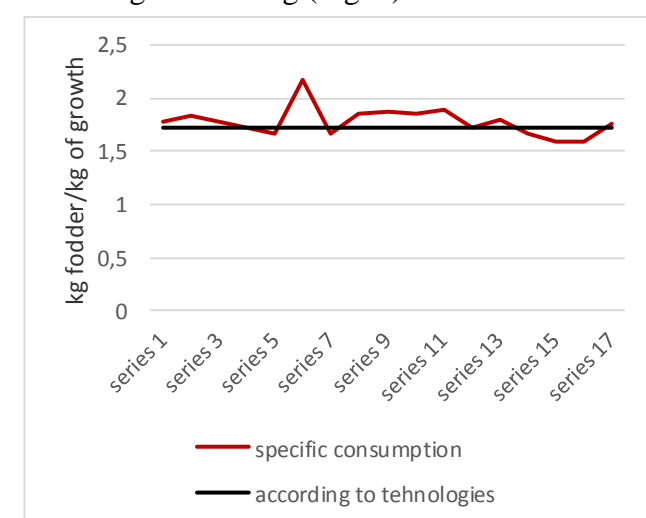

Fig. 3. Evolution of specific consumption/series



The daily average growth as a technical indicator has registered an average value of 39.96 g, with a deviation of 3.08 g from the average and a low variability of 7.7%.

The average weight of the chicken at delivery had an average of 2.06 kg/head, deviating from the average with 0.15 kg and with a variation coefficient of 7.39%.

The quantity of meat delivered/m<sup>2</sup> of premises has reached, for the 17 series, an average value of 22.9 kg/m<sup>2</sup>, with a deviation of 1.27 kg from the average and a variability of 5.55% (Fig 4).

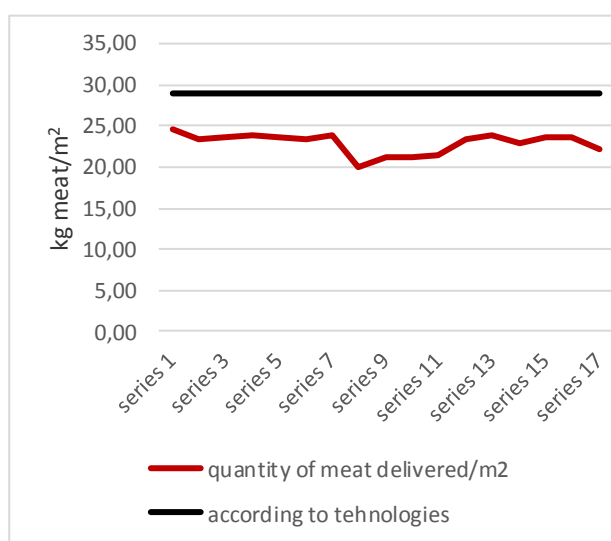

Fig. 4. Evolution of the meat quantity delivered/m<sup>2</sup> of premises/series

The meat chicken raising technology is an industrial technology and thus, a lower variability is specific to it.

The performed analysis indicates that the registered variability was diminished, as a result of observing the technological and organizational discipline.

At the end, the activity of the meat chicken raising farms has to result in profit, which, in the market economy conditions, ensures the restart of the production process.

Below, there is an analysis of the impact of several factors on the financial result. In this regard, we have identified the following factors that have an important influence of the profit: specific consumption, daily average increase, production cost and sales price. The values of these indicators are summarized in Table no. 3

The methodology used was based on the model of multi-factor linear regression. In the analysed econometric model, profit represents the dependent variable and specific consumption, daily average growth, production cost, sales price represent the independent variables.

For data analysis, statistical analysis methods have been used, with the help of Excel application, Data Analysis module.

The hypothesis of the study are:

I<sub>1</sub> – profit is influenced by the specific consumption;

I<sub>2</sub> – profit is influenced by the daily average growth;

I<sub>3</sub> – profit is influenced by the production cost;

I<sub>4</sub> – profit is influenced by the sales price.

The model that verifies the research hypothesis is of the following type:

$$P_i = a_i + b_1 \times SC_i + b_2 \times DAG_i + b_3 \times C_i + b_4 \times SP_i + c_i$$

Where: P = Profit; SC = Specific consumption; DAG = Daily average growth; C = Production cost; PV = Sales price; c = Error, i = Series from 1 to 17. Results of the model regarding the multi-factor regression are presented in Table 4.

The multiple correlation coefficient (r), with a value of 0.995, is the correlation ratio that indicates the existence of a strong connection between profit and the analysed influencing factors.

The determination coefficient - R-square - has a value of 0.991 and expresses the fact that 99.1% of the profit variation is due to the analysed variables. The adjusted correlation ratio indicates that 0.988 of the total variation is resulted from the regression line, taking into account the number of degrees of freedom.

The F test indicates the role of the independent variables in explaining the evolution of the dependent variable. The value of F test (335.57) and of the materiality threshold (0.000000000034 < 0.05) indicates that the regression model is valid and may be used to analyse the dependency between the variables (4).



Table 3. The values of indicators representing the results of Dulbanu No. 1 Farm for the 17 series within the period 2011-2013

specification	Profit (thousand lei)	Specific consumption (kg fodder/kg of growth)	Daily average growth (grams)	Production cost (lei/kg)	Sales price (lei/kg)
Seria 1	734.732	1,780	43.2	3.83	4.81
Seria 2	508.162	1,830	38.1	4.29	5
Seria 3	470.707	1,780	36.1	4.09	4.74
Seria 4	282.713	1,720	43.6	4.21	4.6
Seria 5	419.018	1,670	42.6	4.26	4.84
Seria 6	161.743	2,180	44.9	4.83	5.06
Seria 7	765.552	1,660	40.2	3.78	4.83
Seria 8	344.743	1,860	38.7	4.48	5.04
Seria 9	521.22	1,880	36.1	4.34	5.14
Seria 10	44.891	1,860	36.1	5.76	5.87
Seria 11	85.395	1,900	37.1	4.95	5.08
Seria 12	598.96	1,730	39	5.20	6.04
Seria 13	553.295	1,800	38.8	5.39	6.15
Seria 14	520.283	1,660	43.2	4.53	5.28
Seria 15	592.947	1,600	40.7	4.34	5.16
Seria 16	523.431	1,600	44	4.28	5.01
Seria 17	499.327	1,760	37	4.89	5.63

Source: Farm records

Table 4. Results of the regression function

<i>Regression Statistics</i>	
Multiple R	0.99556
R Square	0.991139
Adjusted R Square	0.988186
Standard Error	22.33719
Observations	17

<i>ANOVA</i>					
	<i>df</i>	<i>SS</i>	<i>MS</i>	<i>F</i>	<i>Significance F</i>
Regression	4	669734.9	167433.7	335.5722042	0.0000000000034
Residual	12	5987.399	498.9499		
Total	16	675722.3			

	<i>Coefficients</i>	<i>Standard Error</i>	<i>t Stat</i>	<i>P-value</i>	<i>Lower 95%</i>	<i>Upper 95%</i>	<i>Lower 95.0%</i>	<i>Upper 95.0%</i>
Intercept	-99.14	158.89	-0.62	0.544332445	-445.32	247.04	-445.32	247.04
Variable 1	-0.02	0.05	-0.34	0.739911669	-0.12	0.09	-0.12	0.09
Variable 2	3.23	1.98	1.63	0.128304273	-1.08	7.53	-1.08	7.53
Variable 3	-733.95	24.78	-29.61	0.000000000001	-787.95	-679.95	-787.95	-679.95
Variable 4	730.30	27.80	26.27	0.000000000006	669.72	790.87	669.72	790.87

Source: Data calculated by the authors

The free term  $a$ , with a value of  $-99.14$  is also the point of intersection between the regression line and OY axis. Because  $t$  statistic =  $-0.62$  and  $P$ - value =  $0.544 > 0.05$ , this coefficient is significantly different from zero, with the confidence interval  $[-445.32; 247.04]$ .

The SC variable coefficient, with the value of  $-0.02$ , is negative and indicates the existence of a reverse type connection between profit and specific consumption, meaning that if the specific consumption increases with 10 gram, the profit will decrease with Lei 0,2 thousand. Because  $P$ - value =  $0.739 > 0.05$ , the coefficient is not significant.

The coefficient of DAG variable, with a value of  $3.23$ , is positive and indicates the existence of a direct connection between profit and daily average growth, meaning that if the daily average growth increases with one gram, the profit will increase with Lei 3.23 thousand. Because  $P$ -value =  $0.128 > 0.05$ , the coefficient is not significant.

The C variable coefficient, with the value of  $-733.95$ , is negative and indicates the existence of a reverse type connection between profit and production cost, meaning that if the production cost increases with Leu 1, the profit will decrease with Lei 733.95 thousand. Because  $P$ - value =  $0.000000000001 < 0.05$ , the coefficient is significant, located within the confidence interval  $[-787.95; -679.95]$ .

The coefficient of SP variable, with a value of  $730.3$ , is positive and indicates the existence of a direct connection between profit and sales price, meaning that if the sales price increases with one Leu, the profit will increase with Lei 730.3 thousand. Because  $P$ - value =  $0.000000000006 < 0.05$ , the coefficient is significant, located within the confidence interval  $[669.72; -790.87]$ .

The results of the created econometric model are influenced by the occurrence of the colinearity phenomenon (1) that occurs when a group of independent variables are strongly correlated between them.

The demonstration of multi-colinearity is performed with the help of the correlation matrix between the independent variable that is presented in Table 5.

Table 5. Matrix of correlation between the independent variables

Specific consumption	1			
Daily average growth	-0.13937	1		
Production cost	0.353308	0.36382	1	
Sales price	0.072695	0.37832	0.861558	1

Source: Data calculated by the authors

The analysis of the results indicates that there is a negative and very weak correlation between the daily average growth and the specific consumption.

The correlation matrix also indicated that there is a weak and positive correlation between the production cost and the specific consumption < between the production cost and the daily average growth, the correlation is negative and weak.

The correlation between the sales price and the specific consumption was very weak, but positive; the correlation between the sales prices and the daily average growth is negative and weak.

The sales price has a very strong and positive correlation with the production cost.

Based on the analysis of the coefficients, the following regression model results:

$$P = -99.14 + (-0.02) \times SC + 3.23 \times DAG + (-733.95) \times C + 730.30 \times SP + c_i$$

The results indicate that the study is valid and the profit was influenced insignificantly by the specific consumption and the average daily growth, but it was influenced in a very significant way by the production cost and the sales price.

## CONCLUSIONS

The development of the economy required the outlining and emphasizing the practical consequences of specifying and designing technologies aimed to the obtaining of competitive results, both technically and economically.

The production process which is performed in view of obtaining a product is the result between the interactions of a set of factors. Knowing these factors and the way in which

they affect the production and costs represents the key premise necessary in preparing a technology.

Because the result of any business activity in the market economy conditions has to be the positive financial results in order to ensure the continuity of activities it is necessary to design technologies with combinations of factors adapted to the conditions existent at the respective moment.

The research performed indicates that, among the multitude of factors influencing the financial result obtained following the application of meat chicken raising technology, it was influenced at a very high level by the production cost and the sales price and at an insignificant level by the production cost and the daily average growth which can also be found in the sold meat production.

## REFERENCES

- [1]Adams, J., Khan, H.T.A., Raeside, R., White, D., 2007, Research Methods for Graduates Busines and Social Science Students. California: Sage PublicationsInc.
- [2]Anghelache Constantin, Badea Sorin Gabriel, Capanu Ion, Wagner Pavel, 2005, Bazele statisticii teoretice și economice, Editura Economică, București.
- [3]Băloiu, M., 1995, Managementul inovației, Editura Eficient, București.
- [4]Bărbulescu, C. et al., 1995, Economia și gestiunea întreprinderii, Editura Economică, București.
- [5]Georgescu, G., Banu, C. et al., 2000, Tratat de producerea, procesarea și valorificarea cărnii, Editura Ceres, București
- [6]Niculae Ioana, Teza de doctorat, 1999.
- [7]Oancea Margareta, 2007, Managementul, gestiunea economică și strategia unităților agricole, Editura Ceres, București.
- [8]Tănăsescu Rodica, Oancea Margareta, Niculae Ioana, Condei Reta, 1997, Managementul în unitățile agricole, Editura Licorna, București.
- [9]Văcaru-Opriș et al., 2002, Tratat de avicultură, Editura Ceres, București.



## ANALYSIS OF IMPROVED HOUSEHOLD SOLID WASTE MANAGEMENT SYSTEM IN MINNA METROPOLIS, NIGER STATE, NIGERIA

Akindele Michael OJO, Esther Ojonugwa OGBOLE, Olanike Alaba OJO

Federal University of Technology, Department of Agricultural Economics and Extension Technology, Minna, P.M.B. 65, Niger State, Nigeria, Phone: +2348033674308, Emails: akinmikky@yahoo.co.uk, ojonikky@yahoo.com

*Corresponding author:* akinmikky@yahoo.co.uk

### *Abstract*

*This study analysed improved household solid waste management system in Minna metropolis, Niger state. Multi-staged sampling technique was used to administer 155 questionnaires to respondents, where Minna was divided into two income groups A and B based on the quality of the respondent's houses. Primary data was collected with the aid of structured questionnaires and analysed using descriptive statistics to obtain results for the socioeconomic characteristics of respondents, types of waste generated and methods of disposing solid waste, the level of awareness and reliability of waste disposal methods as well as the willingness of households to pay for solid waste management in the area. The results revealed that majority of the household heads in the study area were male, 94.20% of the household heads fell between the ages of 21 and 50 and also that 96.80% of them had one form of formal education or the other. The results also revealed that 47.10% and 43.20% of the households generated food wastes and polymers respectively as a major constituent of waste disposed. The results of this study went further to reveal that 81.90% of the household heads were aware of the use of collection cans as a method of waste disposal while only 32.90% of them considered the method highly reliable. Multiple regression was used to determine the factors affecting the willingness of households to pay for waste disposal in the study area. The results showed that 76.10% of the respondents were willing to pay for solid waste management which indicates that households in Minna are concerned and willing to cater for their immediate environment. The multiple regression results revealed that age, income, environmental awareness and household expenditure have a positive and statistically significant relationship with the willingness of households to pay for waste disposal in the area while household size has a negative and statistically significant relationship with households' willingness to pay. Based on these findings, it was recommended that more waste management services be made readily available to residents of Minna, waste collection service should be privatised to increase their effectiveness through increased competition and also that community participatory approach be used to create more environmental awareness amongst residents.*

**Key words:** household, management, solid waste, WTP

### INTRODUCTION

Household solid wastes refer to refuse from households which result from domestic and household activities such as food preparation, sweeping, cleaning, fuel burning and gardening wastes old clothing, old furnishings retired appliances, packaging and reading materials. With rising urbanization and change in lifestyle and food habits of residents, the amount of solid waste has been increasing rapidly and its composition changing [1]. Over the last few years, the consumer market has grown rapidly leading to products being packaged in different forms including the use of cans, aluminium foils, plastics, and other such non-biodegradable

items that cause incalculable harm to the environment [19]. The characteristics and quantity of the solid waste generated in a region is not only a function of the living standards and lifestyle of the region's inhabitants, but also a function of the abundance and type natural resources found in the region.) The quantity and rate of solid waste generation in the various States of Nigeria depends on the population, age, location, education, occupation, level of industrialization, socioeconomic status of the citizens and the kinds of commercial activities being predominant [7]; [8]. The unprecedented growth in urban population has led to expansion in the size of the Nigerian cities, with drastic changes in land allocation

for residential, commercial, industrial and educational activities. This is further increasing the dimensions of environmental and health hazards resulting from drainage blockages, waste accumulation, disposal problems, noise pollution, among others. There are a number of problems associated with inappropriate waste management mechanism in the densely populated localities. The open waste piles create health problems and pollute the underground water, ultimately causing waterborne diseases [15]

To improve this pressing problem the government and other stakeholders have to put maximum efforts to look for the possibility of managing these wastes properly. Waste management is the generation, prevention, characterization, monitoring, treatment, handling, reuse and residual disposition of solid wastes [19]. It refers to all processes in the proper disposal or recycling of rubbish and garbage. For example solid wastes which do not take time to degenerate can be buried in dump-pits. This is a way of improving soil fertility because on the long run, these wastes decompose as a result of microbial activities which turns them into compost manure which adds less hazardous nutrients to the soil. Plastics can be recycled, wood can be used to make fires, and parts of some discarded appliances can be used to manufacture some other new appliances. Wastes that are not well managed can affect the environment in terms of the contamination of the atmosphere, soil and water. This can cause severe problems for humans and animals population. It can also affect human health in particular by causing convulsion, dermatitis, irritation of nose/throat, anaemia, skin burns, chest pains, blood disorders, stomach aches, vomiting diarrhoea and lung cancer which may lead to death [6] [12] [4]

In order to clean up the urban area of waste the local authorities have used the strategy of collecting what has been deposited by the urban dwellers without a viable measure of inhibiting the deposition. This effort has proved extremely insufficient as evidenced by the continued piling up of waste heaps in almost every street corner. With the increase in the waste heaps in the street, the residents

demand a better environmental quality. Considering the rapid spatial and population growth of most urban areas with decreasing coverage levels, and with increase in level of waste generated, confronted by increasing public demand for improved services [15], the need arises for a more efficient method of waste management.

This therefore gives rise to the need to evaluate the household solid waste management system in the study area.

Specifically the study examined the types of waste generated and methods of disposing solid waste, level of awareness and reliability of waste disposal methods, the willingness of households to pay for solid waste management and the factors affecting willingness of households' to pay for solid waste management in the study area.

Contingent Valuation Method (CVM) [5] was used to estimate the determinants of household willingness to pay for solid waste management. The contingent valuation method is superior to other valuation methods because it is able to capture use and non-use values.

Other valuation methods like Hedonic Pricing and Travel Cost method tend to underestimate satisfaction derived from services rendered since they measure use values only.

The contingent valuation technique however suffers from one major drawback despite its ability to measure total economic values. The hypothetical nature of the questions used in contingent valuation method surveys may create problems since respondents may have little incentive to provide information on their true willingness to pay.

## **MATERIALS AND METHODS**

The study was conducted in Minna Metropolis (which contains Bosso and Chanchaga Local Government Areas (LGAs), Niger State, Nigeria. Niger State is located between latitudes 8°11'N and 11° 20' N and longitude 4° 30'E and 7° 20'E. It is bordered on the North-east by Kaduna State and on the South-east by the Federal Capital Territory, Abuja. It is also bordered on the North, West, South West and South by Zamfara, Kebbi,

Kogi and Kwara States. The State covers an estimated land area of 76,363 square kilometers and a population of 4,082,558 people [19]. The State is agrarian and well suited for the production of arable crops such as cassava, cowpea, yam, and maize because of favourable climatic conditions. The annual rainfall is between 1100mm and 1600mm with average monthly temperature ranges from 23oC to 37oC [19]. The vegetation consists mainly of short grasses, shrubs and scattered trees.

### Sampling Technique

The data from primary source were used for this study. Multi-staged sampling technique was used to select the respondents. The first stage involved the stratification of Minna into two income groups. This step is very important but was quite difficult because willingness to pay for improved solid waste management involves demand estimation and its main determinant is expected to be income [5]. Minna was roughly divided into two income groups using the quality of housing in the absence of any other formal way of stratification. These income groups were further stratified using random sampling technique where households were selected at random for distribution of questionnaires. A total of 172 questionnaires were distributed. Eighty-six copies to high income group areas (group A) and Eighty-six copies to low income group areas (group B), out of these 172 questionnaires, only 155 were recorded as valid, this is as a result of the fact that some household heads were not willing to participate in the survey.

### Method of Data Collection

The primary data were collected using structured questionnaires and interview schedule for different household heads in Minna metropolis. The contingent valuation survey was used to obtain an estimate of the value of improvements in solid waste management in the study area. This study used the contingent valuation method (CVM) to elicit the willingness to pay values. In this procedure the household heads were free to answer the open-ended questions by indicating the maximum amount they are willing to pay. The household heads were first

asked whether they are willing to pay anything at all for solid waste management services. The respondents, who said 'no,' were asked to give the reason(s). For household heads who said 'yes', were asked to choose an amount of money from a payment list that corresponded to the maximum amount they are willing to pay monthly for the solid waste management services. Data collected include the socioeconomic characteristics of the household heads e.g. age, sex, income, household size, marital status and all the relevant information needed for this study.

### Analytical techniques

Descriptive statistics was used to identify the types of waste generated as well as methods of disposing solid waste in Minna while multiple regression was used to examine the factors affecting willingness of households' to pay for solid waste disposal in Minna. The contingent valuation survey was used to obtain an estimate of the value of improvements in solid waste management in the study area.

The multiple regression model used to estimate the factors affecting willingness of households' to pay for solid waste disposal in the study area is expressed as:

$$WTP = \alpha + \beta_1 AGE + \beta_2 EDU + \beta_3 H\_SIZE + \beta_4 SEX + \beta_5 H\_OWN + \beta_6 W\_SER + \beta_7 INCOME + \beta_8 E\_AWR + \beta_9 W\_QNTY + \beta_{10} N\_DMPS + \beta_{11} EXP + ui$$

where:

WTP = Willingness to pay for waste management services (Maximum amount the household heads are willing to pay in Naira).

AGE = Age (years)

EDU = Education level (years spent in school)

H SIZE = House hold size.

SEX = Sex (1 if male; 0, otherwise)

HOWN = House ownership, (1= owner of the house and 0 = non owners)

WSER = Waste collection services, (1, if available; 0, otherwise)

INCOME = Income level of the households (Naira)

EAWR = Awareness on environmental effect of improved solid waste disposal (1 if aware; 0, otherwise)

WQNTY = Quantity of waste generated per

month (kg).

NDMPS = Nearness to dumpsite (1 if near; 0, if far away)

EXP = Household expenditure (Naira)

$\mu_i$  = The random error term

## RESULTS AND DISCUSSIONS

Types of waste generated and methods of disposal

The results of the types of waste disposed by households in the study area are shown in Table 1. The results in Table 1 revealed that most of the households in Minna metropolis generated food waste (47.10%) and polymers in the form of pure water bags (43.20%), since most houses depend on the supply of sachet water as their main source of drinking water.

Table 1. Major constituents of waste generated from households in the study area

Wastes	Frequency	Percentage
Papers	24	15.50
Food waste	73	47.10
Glasses	7	4.50
Plastics	13	18.40
Batteries	4	2.60
Polymers	67	43.20
Wood products	8	5.20
Metallic materials	6	3.90
Packaging materials	21	13.50

\* = Multiple response were allowed

Source: Field survey, 2014

Only 5.20% and 4.50% of the household disposed wood products and glasses as waste respectively.. This finding is in disagreement with the results of [16], where plastics, packaging materials and papers (99%, 99% and 97% respectively) were reported to be the major constituent of waste generated in most cities in the country.

The results of the major waste disposal methods adopted by households and their reliability are shown in Table 2. Table 2 shows that 20.60% of the respondents disposed their waste in open spaces; this may be as a result of convenience since these people are closer to dump sites than collection cans while others chose this method because of their unwillingness to pay for waste disposal. This corresponds with the findings of [16] who reported that 47% of the

households dispose their waste in open spaces as a result of long distance from collection cans.

Table 2. Waste disposal methods and Reliability of methods in the study area

Disposal Method	Frequency	Percentage
Throw to open space	32	20.65
Use collection cans	69	44.52
Burn	38	24.52
Sale for recycle	1	0.65
Re-use at home	2	1.29
Take to latrines	6	3.87
Dig open pit	4	2.58
Use of waste vendor	28	18.06
<b>Waste disposal method Reliability</b>		
Throw to open space	23	14.84
Use collection cans	68	43.87
Burn	30	19.35
Sale for recycle	40	25.81
Re-use at home	23	14.84
Take to latrines	8	5.16
Dig open pit	30	19.35
Use of waste vendor	39	25.16

\* = Multiple response allowed

Source: Field survey, 2014

Table 2 also revealed that 44.50% of the households disposed their waste by using collection cans provided by the State government. The results in Table 2 further revealed that 43.87% of the households indicated the use of collection cans by the State government as the most reliable method of waste collection in the study area. This implies that more effort is required by the State government to make more waste collection cans available and accessible to the people in the study area.

The results of the household willingness to pay for solid waste disposal are shown in Table 3. The results in Table 3 show that 76.10% of the households were willing to pay for waste disposal. This implies that given the advantages of improved services, most households in the study area were willing to pay part of their income, to sanitise their immediate environment. This result agrees with that of [1] who also reported that 87.5% (a majority) of the households were willing to pay for solid waste disposal in Nigeria. Table 3 further shows that 7.70% of the population gave a reason of meager income for their unwillingness to pay. While 6.50% gave the reason of lack of enough information about solid waste management.



Table 3. Household willingness to pay for solid waste disposal in the study area

	Frequency	%
Willing to pay	118	76.10
Not willing to pay	37	23.90
<b>Reasons for not being willing to pay:</b>		
1. Meagre income	12	7.70
2. Not willing to place a naira value	8	5.20
3. Not well informed about it	10	6.50
4. Don't want to participate in the survey	2	1.30
5. Solid waste management is of no value	5	3.90

Source: Field survey, 2014

The results of the regression model showing the factors affecting the household willingness to pay for waste management services in the study area are shown in Table 4. The value of the coefficient of determination (R<sup>2</sup>) indicated that 58.06% of the variations in willingness to pay response were explained by the factors in the regression model. The F-value 3.44, is significant at (P<0.01) percent, meaning that the variables included in the model jointly and significantly explained the variations in willingness of household to pay for solid waste disposal service in the study area.

Table 4. Regression results for factors affecting the respondents' willingness to pay for waste disposal service in the study area

Variables	Coefficients	T-values
Age (X <sub>1</sub> )	0.89	2.03**
Education (X <sub>2</sub> )	-0.11	-0.81
Household size (X <sub>3</sub> )	-0.25	-1.80*
Sex (X <sub>4</sub> )	-0.16	-0.67
House ownership (X <sub>5</sub> )	-0.32	-0.97
Waste collection services (X <sub>6</sub> )	-0.18	-0.68
Income (X <sub>7</sub> )	0.22	2.36**
Environmental awareness (X <sub>8</sub> )	0.59	1.69*
Waste quantity (X <sub>9</sub> )	-0.12	-0.69
Nearness to dumpsite (X <sub>10</sub> )	0.13	0.53
Household Expenditure (X <sub>11</sub> )	0.43	2.80***

F-value = 3.44\*\*\*

R-squared = 0.5806

\*\*\* = significant @ 0.01 probability level, \*\* = significant @ 0.05 probability level and \* = significant @ 0.10 probability level

Source: Field Survey, 2014

The regression coefficients of age (X<sub>1</sub>), income (X<sub>7</sub>), environmental awareness (X<sub>8</sub>) and household expenditure (X<sub>11</sub>) were positive and statistically significant. This implies that increased in these variables, all other variables held constant led to an increase in willingness to pay for solid waste disposal service by household in the study area. This result is not unexpected because increase in income and awareness about health implications of unclean environment will definitely lead to the demand for high

environmental quality. Also, the contingent valuation study is based on how much people are willing to put a money value on improved solid waste management and this ability is influenced by income.

This result agrees with the findings of [5], [9],[16], [15] who reported that the household willing to pay for solid waste disposal service is positively related to the income, expenditure, age and awareness of the household in the cities. The regression result further shows that household size was negatively related to the household willingness to pay for waste disposal service in the study area. This result is confirmed by the finding of [1] who reported that household size is negatively related with the willingness of households to pay for solid waste disposal service.

## CONCLUSIONS

This study examined the household solid waste management system in Minna metropolis, Niger State, Nigeria.

This study revealed that food waste and polymers were the major constituents of waste generated from households in the study area, while most of them indicated the use of collection cans provided by the State government as the most reliable method of waste collection in the study area.

Majority of the households were willing to pay to sanitise their immediate environment given the advantages of improved waste management services.

Also, the findings further revealed that age, income, household expenditure, environmental awareness and household size had influence on the value placed on the service of solid waste management.

Based on the findings of this study, it is therefore recommended that community participatory approach should be used by government to create more awareness on solid waste management among the people.

Also, private waste collection services should be encourage in the study area, this will go a long way in improving the effectiveness waste collection in the metropolis.

## REFERENCES

- [1] Adebo, G.M., Ajewole, O.C., 2012, Gender and urban environment: analysis of willingness to pay for waste management disposal in Ekiti State, Nigeria. *American Journal of Contemporary Research*. 2(5):228 – 234.
- [2] Adewumi, I. K., Ogedengbe, M. O., Adepetu J. A., Fabiyi Y. L., 2005, Planning organic fertilizer industries for municipal solid wastes management. *Journal of Applied Sciences Research*. Vol. 1(3): 285-291.
- [3] Adewuyi, G.O., Obi-Egbedi, N.O. Babayemi, J.O., 2008, Evaluation of ten different african wood species for potash production. *International Journal of Physical Science*, 3(3): 63- 68.
- [4] Afroz, R., Hanaki, K., Hasegawa-Kurisa, K., 2009, Willingness to pay for waste management improvement in Dhaka city, Bangladesh. *Journal of Environment Management* 90, 492-503
- [5] Aggrey, N., Douglason, O. G., 2010, Determinants of willingness to pay for solid waste management in Kampala City. *Current Research Journal of Economic Theory*, 2(3): 119-122
- [6] Alabi, M., 2004, Waste products survey for identification and quantification of different wastes generated in Nigeria. An Unpublished PhD Thesis in the Department of Geology, University of Ibadan. Pp. 44 – 56
- [7] Ajani, O.I.Y, 2007, Determinants of an effective solid waste management in Ibadan Metropolis, Oyo State, Nigeria. *Journal of Food, Agriculture and Environment*. 6(1):152-157.
- [8] Babayemi, J. O., Dauda, K. T., 2009, Evaluation of solid waste generation, categories and disposal option in developing countries: A case study of Nigeria. *Journal of Applied Science Environment Management*. 13(3): 83-88.
- [9] Banga, M., Lokina, R.B., Mkenda, A.F., 2011, Households' willingness to pay for improved solid waste collection services in Kampala city, Uganda. *The Journal of Environment and Development* 20, 428-448.
- [10] Bassey, B. E., Benka, M. O., Aluyi, H. S. A., 2006, Characterization and management of solid medical wastes in the Federal Capital Territory, Abuja, Nigeria. *African Health Sciences*. 6(1): 58-63.
- [11] Imam, A. Mohammed, B., Wilson, D.C., Cheeseman, C.R., 2008, Solid waste management in Abuja, Nigeria. *Waste Management*. 28(2): 468-472.
- [12] Jin, J., Wang, Z., Ran, S., 2006, Comparison of contingent valuation and choice experiment in solid waste management programs in Macao. *Ecological Economics* 57, 430-441.
- [13] Kayode, A. M., Omole, F. K., 2011, Some socioeconomic factors affecting solid wastes generation and disposal in Ibadan Metropolis, Nigeria. *Journal of Environmental Issues and Agriculture in Developing Countries*. 3(1): 55-64.
- [14] Longe, E.O., Williams, A., 2006, A preliminary study of medical waste management in Lagos metropolis, Nigeria. *Iranian Journal of Environmental Health, Science and Engineering*. 3(2):133-139
- [15] Raheel, A., 2013, Willingness to pay for solid waste management services: a case study of Islamabad. Pakistan Institute of Development Economics, Islamabad. Conamera Environmental Education and Cultural Centre (CEECC) Working Paper No. 3. Pp 1-21 <http://www.pide.org.pk>
- [15] Salifu, L., 2001, 'An integrated waste management strategy for Kumasi' In: Drechsel, P. and D Kunze (eds), op.cit., pp. 112-114.
- [16] Sumukwo J., Kiptui, M., Cheserek, G. J., 2012, Economic valuation of improved solid waste management in Eldoret Municipality. *Journal of Emerging Trends in Economics and Management Sciences (JETEMS)*. 3(6): 962-970
- [17] Yusuf, R.O., Oyewumi, M.O., 2008, Qualitative assessment of methane generation potential for municipal solid wastes: A Case Study. *Environmental Research Journal, Medwell Journals*. 2(4):138-144.
- [18] Yusuf, S.A., Ojo, O.T., Salimonu, K.K., 2007, Household Willingness to pay for Improved household solid waste management in Ibadan–North LGA of Oyo State, Nigeria. *Journal of Environmental Extension University of Ibadan*. Vol. 6, pp 57 – 63.
- [19] Waste Management, 2011, Encyclopedia. Retrieved on June 6, 2014 from [en.wikipedia.org/wiki/waste\\_management](http://en.wikipedia.org/wiki/waste_management).

## RURAL EMPLOYMENT GENERATION AND POVERTY ALLEVIATION THROUGH SMALL SCALE CASSAVA PROCESSING VENTURES IN NIGER STATE, NIGERIA

**Olanike Alaba OJO, Alice INIJEZE, Akindele Michael OJO, Safiya JIBRIN**

Federal University of Technology, Department of Agricultural Economics and Extension Technology, Minna, P.M.B. 65, Niger State, Nigeria, Phone: +2348033674308, Emails: ojonikky@yahoo.com, akinmikky@yahoo.co.uk

**Corresponding author:** ojonikky@yahoo.com

### **Abstract**

*The study was conducted on rural employment generation and poverty alleviation through small scale cassava processing ventures in Niger State, Nigeria. Primary data were collected using a structured questionnaire and the analytical techniques involved the use of ordinary least square, Foster, Greer and Thorbecke (FGT) poverty index and binary logit regression models. The study revealed that four cassava products namely garri, cassava flour (lafun), fufu and starch were the major products from cassava processing in the area and that it provided full employment for 81% of the cassava processors in the area. The study showed that cassava processing was profitable in the area. The logit regression result revealed that age and amount spent on feeding by the processors were statistically significant at 5% and 10% probability level, respectively but negatively related to the poverty status of the processors. This implies that the probability of the cassava processor living above poverty line decreased with age and amount spent on feeding while the probability of the processors living above poverty line increased with increased in assets ( $p \leq 0.05$ ), quantity of cassava processed ( $p \leq 0.01$ ) and years of experience ( $p \leq 0.01$ ). The mean income/day/processor was ₦275 which implied that cassava processing alleviated poverty in the area. The results of partial elasticity revealed that quantity of cassava processed, years of experience, value of assets and amount spent on feeding were elastic. In conclusion, cassava processing was a source of employment for majority of the processors and also had ability of alleviating poverty among the rural folks in the study area.*

**Keywords:** elasticity, poverty, Nigeria, rural employment

### **INTRODUCTION**

Poverty is the lack of, or inability to achieve, a socially acceptable standard of living and/or, the possession of insufficient resources to meet basic needs required for sustenance and well being [12]. It is a plague that has eaten deep into different people across nations of the world. Although it is a universal phenomenon that affects socio-economic and political well being of its victims across board, available statistics shows that poverty in poor country is absolute and more pronounced in the rural areas[13]. Agricultural sector which absorbs about 70%of the labour force in Nigeria is a very important sector in the economy with high potentials for employment generation, food security and poverty reduction (Federal Ministry of Agriculture and Rural Development, 2011). However, one of the

problems faced in Nigeria and Niger State in particular, is how to improve on the production capacity, the productivity as well as ability to change the forms of our staple crops (such as cassava) into various alternative consumables and industrial by-products to minimize waste, increase availability of foodstuffs, employment generation capacity and earnings and eventual reduction in hunger, malnutrition and poverty among the small scale farmers.

To this end, the Presidential Initiative on Cassava (PIC) was launched in 2002 to create awareness among farmers on the opportunities in cassava market world-wide and also targeted at producing tonnes of processed cassava products such as garri, pellet, chips, starch and flour. It sets in motion the process of achieving economic growth through cassava production and processing. Between 2002 and 2010, International Institute of

Tropical Agriculture (IITA) implemented the Integrated Cassava Project (ICP) to support the PIC and in the process, introduced and promoted more than 40 cassava varieties to Nigerian farmers and facilitated the establishment of hundreds of processing centres [7]. Despite these efforts by the Federal Government, most of the cassava processors are yet to tap the full potentials embedded in cassava processing that could attract the attention of private entrepreneurs in the sector. It is against this backdrop that the study is aimed at identifying the proportion of processors that are fully employed in cassava processing and determine the effect of cassava processing on poverty status in the study area.

### Conceptual framework

Poverty can be generally understood as the lack of, or inability to achieve, a socially acceptable standard of living, or the possession of insufficient resources to meet basic needs [12]. A commonly used approach to assess poverty is the construction of a poverty line and computation of different measures which take into account the way in which household expenditures fall short of the poverty line [4]. Hence, poverty lines are established to divide the poor from the non-poor. Poverty can be assessed by constructing a poverty index which makes use of a range of quantitative and qualitative indicators. Credible information can be obtained quickly and inexpensively with a tool of this type that uses indicators to describe different dimensions of poverty [4]. However, the most common three poverty measures of the FGT class [6] are the headcount, the poverty gap, and the squared poverty gap. Poverty Headcount is the share of the population which is poor, i.e. the proportion of the population for whom consumption or income  $y$  is less than the poverty line  $z$ . Suppose we have a population of size  $n$  in which  $q$  people are poor. Then the headcount index is defined as:

$$\frac{N}{H} = q \tag{1}$$

Poverty Gap (depth of poverty) is the mean distance separating the population from the poverty line, with the non-poor being given a

distance of zero. It is a measure of the poverty deficit of the entire population, where the notion of poverty deficit captures the resources that would be needed to lift all the poor out of poverty through perfectly targeted cash transfers. It is defined as follows:

$$P\alpha = \frac{1}{n} \sum_{i=1}^q \left[ \frac{z - y_i}{z} \right] \tag{2}$$

where  $y_i$  is the income of individual  $i$ , and the sum is taken only on those individuals who are poor. It can be written as being equal to the product of the income gap ratio and the headcount index of poverty, where the income gap ratio is itself defined as:

$$PG = I * H,$$

$$\text{where, } I = \frac{z - y_q}{z} \text{ and } y_q = \frac{1}{q} \sum_{i=q}^q y_i \text{ is the average income of the poor.} \tag{3}$$

It must be emphasized that the income gap ratio  $I$  in itself is not a good measure of poverty.

Assume that some households or individuals who are poor but close to the poverty line are improving their standards of living over time, and thereby become non-poor. The Income gap ratio will increase because the mean distance separating the poor from the poverty line will increase (this happens because some of those who were less poor have emerged from poverty so that those still in poverty are on average further away from the poverty line), suggesting a deterioration in welfare, while nobody is worst off and some people are actually better off. Although the income gap ratio  $I$  will increase, the poverty gap itself  $PG$  will decrease, because the headcount index of poverty will decrease, suggesting an improvement towards poverty reduction. The problem with the income gap ratio is that it is defined only on the population that is poor, while the poverty gap is defined over the population as a whole. As mentioned above, the poverty gap is a useful statistics to assess how much resources would be needed to eradicate poverty through cash transfers perfectly targeted to the poor. Squared Poverty Gap is often described as a measure

of the severity of poverty. While the poverty gap takes into account the distance separating the poor from the poverty line, the squared poverty gap takes the square of that distance into account. When using the squared poverty gap, the poverty gap is weighted by itself, so as to give more weight to the very poor. Said differently, the squared poverty gap takes into account the inequality among the poor. It is obtained as follows:

$$P2 = \frac{1}{n} \sum_{i=1}^q \left[ \frac{z - y_i}{z} \right]^2 \quad (4)$$

The headcount, the poverty gap, and the squared poverty gap are the first three measures of the Foster-Greer-Thorbecke class of poverty measures. The general formula for this class of poverty measures depends on a parameter  $\alpha$  which takes a value of zero for the headcount, one for the poverty gap, and two for the squared poverty gap in the following expression:

$$P\alpha = \frac{1}{n} \sum_{i=1}^q \left[ \frac{z - y_i}{z} \right]^\alpha \quad (5)$$

It is important to use the poverty gap or the squared poverty gap in addition to the headcount for evaluation purposes, since these measure different aspects of income poverty. Indeed, the basing of evaluation on the headcount ratio would consider as more effective policies which lift the richest of the poor (i.e those close to the line) out of poverty. On the basis of the poverty gap PG and the squared poverty gap P2, on the other hand, puts the emphasis on helping those who are further away from the line, the poorest of the poor.

## MATERIALS AND METHODS

The study was carried out in Niger State, Nigeria. It is located in the North-central zone of the country and lies between latitude of 8° 22' N and 11° 30' N and longitude 3° 30' E and 7° 20' E. It is bordered to the north by Sokoto State, west by Kebbi State, South by Kogi and South-West by Kwara State, Kaduna and the

Federal Capital Territory border the State to both North-East and South-East, respectively. The State has a common boundary with the Republic of Benin along New Bussa, Agwara and Wushishi Local Government Area of the State. This has given rise to common inter-border trade between the two countries. It has a population of about 3, 950, 249 people [9]. The projected population of the State for 2014 is 5,235,294 people at 3.4% growth rate according to (United Nations Funds for Population Activities [15]). It covers a total land area of 83,266,779 square kilometres which represent 8% of the total land area of Nigeria. About 85% of the land is arable. It experiences distinct dry and wet seasons with annual rainfall varying from 1,100mm-1,600mm per annum and average monthly temperature ranging from 23°C to 37°C. Generally, the climate, soil and hydrology of the State permit the cultivation of most of Nigeria's staple crops and still allows sufficient opportunities for grazing, fresh water fishing and forestry development. About 85% of the State's population are farmers, while the remaining 15% are engaged in other vocations such as white collar jobs, manufacturing, business, production of crafts and arts.

### Data collection and sampling Procedure.

Primary data were collected with the aid of structured questionnaire. A multi-stage sampling technique was used to select the processors in the study area. The first stage involved the random selection of two out of the twenty-five Local Government Areas (LGAs) of the State. The second stage involved random selection of two villages from each LGA while in the third stage twenty five households were randomly selected from each village/towns making a total of hundred cassava processors in the study area.

### Data Analytical Techniques and Model Specification.

Budgetary analysis was used to determine the profitability of the cassava processing ventures in the study area. The net margin is the net earnings which a processor earns after paying all marketing costs. Net earnings of the processors was computed using the

following formulas:

$$\text{Gross Margin (GM)} = \text{GI} - \text{TVC} \quad (6)$$

Where,

GM = Gross Margin,

GI = Gross Income,

TVC = Total Variable Cost.

Therefore,

$$\text{Net Profit (NP)} = \text{GM} - \text{TFC} \quad (7)$$

Where:

NP = Net Profit,

TFC = Total Fixed Cost

The profitability index measures the profitability of a proposed business or project.

It attempts to identify the relationship between costs and benefits of the business and it is represented by:

$$\text{PI} = \text{Profitability Index} = \text{NI/TR} \quad (8)$$

Where,

NI = Net Income

TR = Total Revenue

Rate of return on investment is the ratio of the gain and loss from an investment to the initial investment amount. It is given by the formula in equation (9)

$$\begin{aligned} \text{RRI (Rate of Return on Investment)} \\ = \frac{\text{NI}}{\text{TC}} \times 100 \end{aligned} \quad (9)$$

Where,

NI = Net Income

TC = Total Cost

To analyse the determinants of profitability of the processors, multiple regression model was used. This is specified implicitly as:

$$Y_i = f(X_1, X_2, X_3, X_4, X_5, X_6, U_i) \quad (10)$$

Where,

$Y_i$  = Net income (₦).

$X_1$  = Quantity of cassava processed (kg)

$X_2$  = Labour (Man-days)

$X_3$  = Age of respondent (years).

$X_4$  = Experience (years).

$X_5$  = Depreciation (₦).

$X_6$  = Cost of firewood (₦)

$X_7$  = Packaging cost (₦)

$X_8$  = Availability of market (1 if yes, 0 otherwise)

$X_9$  = Transportation Cost (₦)

$X_{10}$  = Storage cost (₦)

$U_i$  = Error term.

Four functional forms namely, linear, Cobb-Douglas, semi-log and exponential forms

were used and the best fit was selected based on the number of significant variables, coefficient of determination and F-ratio.

Poverty indices of the households were determined using [6] analysis model as used by [11]. The FGT model postulated that there are three different ways by which poverty can be measured which are headcount, poverty gap and squared poverty gap. The basic formula for the model is:

$$P\alpha = \frac{1}{n} \sum_{i=1}^q \left[ \frac{z - y_i}{z} \right]^2 \quad (11)$$

Where,

$z$  = the poverty line

$q$  = the number of processors below poverty line.

$n$  = the total number of individual in the sampled population.

$y_i$  = the income of the  $i$ th processors/household

$\alpha$  = poverty aversion parameter and takes on the values 0, 1 and 2, representing incidence depth or severity of poverty.

$P$  = Poverty gap

When  $\alpha = 0$ , then  $P$  will be reduced to headcount ratio which measures the incidence of poverty; when  $\alpha = 1$ , it shows the intensity of poverty that is, how far the processors are below the poverty line and  $\alpha = 2$  gives the severity of poverty.

The poverty line was set at the international poverty line of US\$ 1per day following the work of [1] which translated to ₦5,040 per month at the prevailing exchange rate of ₦168 per dollar. Therefore, any rural processor whose income per month fell below ₦5040 was considered poor. Those whose income fell below one third of the poverty line, that is, ₦1680 were considered “very poor”, those whose income fell between 1/3 and 2/3 of the poverty line (₦1680-₦3360) were termed “moderately poor”, those whose income were between 2/3 of the poverty line and the poverty line (That is, ₦3360 - ₦5040) were considered “poor” while those whose income was greater than the poverty line were considered “non poor”.

The logit regression model was used to determine the effect of cassava processing on

poverty status of the processors and it is represented as:

$$\ln Y = \beta_0 + \sum_{i=1}^n \beta_i X_i \quad (12)$$

Where,

Y = Poverty status of the processors (1= non-poor i.e income > ₦5,040 and 0 = poor i.e income < ₦5,040)

X<sub>1</sub> = Quantity of cassava processed (₦)

X<sub>2</sub> = Health status of the processors (No. of days absent from processing activities due to ill-health)

X<sub>3</sub> = Age of respondent (years)

X<sub>4</sub> = Experience (years)

X<sub>5</sub> = Household size (No.)

X<sub>6</sub> = Assets ownership (₦)

X<sub>7</sub> = Amount spends on feeding per month (₦).

U<sub>i</sub> = Error term

## RESULTS AND DISCUSSIONS

**Proportion of processors involved in cassava processing.** Table 1 shows the distribution of the processors based on the types of cassava products produced. It was revealed that all the processors were fully involved in cassava processing. Specifically, all the processors produced garri (100%), followed by cassava flour (43%) and starch (26%), respectively. Fufu ranked 4th and had only 9%. The implication of this is that cassava processing was a source of rural employment in the study area. Moreover, garri which ranked first was an indication that it was a widely acceptable staple food in the study area and had the highest demand.

Table 1. Distribution of Processors based on the Types of Cassava Products Produced

Products	*Frequency	Percentage	Rank
Garri	100	100	1 <sup>st</sup>
Cassava Flour	43	43	2 <sup>nd</sup>
Starch	26	26	3 <sup>rd</sup>
Fufu	9	9	4 <sup>th</sup>

Source: Field Survey, 2014 \*Multiple response were allowed

This is line with the study of [8] on the assessment of the economics of cassava processing in Kwara State, Nigeria who

revealed that four cassava products namely garri, cassava flour (lafun), fufu and starch were the major products from cassava processing in the area.

**Cost and Returns of the Processors.** The cost and return analysis of the processors is as shown in Table 2 and 3. From Table 2, the total estimated cost was 209.57/kg/processor. Cost of tubers accounted for ₦70.91 followed by transportation costs ₦30.56, variable inputs accounted for ₦21.46, labour cost ₦20.49, storage cost ₦18.37 and packaging costs ₦16.81. The estimated total revenue accounted for ₦341.88/kg/ processor and gross margin of ₦163.28/kg/processor. The net income was ₦132.31/kg/processor. The Profitable Index was 0.39 which implied that 39% of the total revenue generated constituted the net income. This showed an appreciable level of profit. The Rate of Returns on Investment (IRR) was 63% which showed that each processor earned 0.63 kobo profit on every Naira spent. This likewise showed that cassava processing in the study area was profitable.

Table 2. Costs and returns on analysis of cassava processing

Item	Amount(₦)/kg/processor
Variable costs	
Packaging cost	16.81
Storage cost	18.37
Labour cost	20.49
Cost of firewood and palm oil	21.46
Cost of cassava tubers	70.91
Transportation cost	30.56
Total Variable Cost	178.60
Fixed cost	
Depreciation	30.97
Total Fixed Cost	30.97
Total Cost	209.57
Revenue	341.88
Gross margin	163.28
Net Income	132.31

Source: Field Survey, 2014

**Determinants of Profitability of Cassava Processing:** Four functional forms were estimated and based on economic, statistical and econometric criteria, the Cobb Douglas functional form was chosen as the best fit.



Table 3. Gross margin analysis of Cassava processing

Variable	Value (₦)
Total Revenue	341.88
Gross margin	163.28
Net income	132.31
Profitability index	0.40
Rate of return on investments	63%

Source: Field Survey, 2014

Quantity of cassava processed ( $X_1$ ) was significant at 1% while the years of experience ( $X_4$ ), transportation cost ( $X_9$ ) and storage cost ( $X_{10}$ ) were all significant at 5% levels. Furthermore, availability of market ( $X_8$ ) and age of the processors ( $X_3$ ) were significant at 10%. From Table 4, the positive regression coefficient of quantity of cassava processed ( $X_1$ ), years of experience ( $X_4$ ), availability of market ( $X_8$ ) showed that an increase in these variables will lead to an increase in the profitability of the processors whereas an increase in the age, transportation and storage costs will reduce the profitability of the processors in the study area. In essence, the longer a processor stays in the business, the more experienced and efficient he becomes in handling the operations.

Table 4. Regression Analysis of Determinants of Profitability of Cassava Processing

Explanatory variables	Coefficient	T - ratio	Standard error
Quantity of cassava	0.835	13.3327** *	0.139
Labour	-0.086	-1.455	0.102
Age	-0.143	-1.919*	0.247
Experience	-0.182	2.389**	0.150
Depreciation	0.048	0.612	0.067
Cost of Firewood	-0.056	-0.707	0.133
Packaging	0.002	0.036	0.092
Cost			
Availability of Market	0.101	1.750*	0.169
Transportation cost	-0.119	-2.052**	0.140
Storage cost	-0.130	-2.132**	0.071

Source: Field Survey, 2014 \*\*\* Significant at 1%, \*\* Significant at 5%, \*Significant at 10%.  $R^2 = 0.731$  and  $F = 23.966$ \*\*\*

Also, the more the experience the lesser the risk encountered and this will lead to greater profit.

This conforms to the study of [2] study on

economic analysis of cassava processing into garri in Oyo State, Nigeria which revealed that years of experience of garri processors showed a positive relation and was significant at 1% meaning that they have direct effect on profit of the processors.

The F- ratio of 23.966 showed that the overall model was significant at 1% Level while the Coefficient of Determination ( $R^2$ ) was 0.731. This implied that 73% of the variations observed in profitability level of the processors were explained by the included explanatory variables.

**Poverty Status of Processors.** The international poverty line of US\$1 per day per person was adopted for this study. This translated to ₦5040 per month at the exchange rate of ₦168 per dollar (This was the prevailing rate during the period of the survey). Thus, any rural processor whose income per month falls below ₦5040 was considered poor.

Table 5 revealed that 41% of the processors were poor while 59% of the processors were non-poor. The mean income/day/processor was ₦275. This suggests that cassava processing was an effective measure in alleviating poverty in the study area. This was corroborated in the study conducted by [1] on effect of poverty on risk attitude of rural women investors in Osun State, Nigeria where 58.6% respondents were poor.

Table 5. Distribution Processors by Poverty Levels

Poverty level	Amount(N)	Frequency	Percentage
Very poor	<1680	4	4.0
Moderately poor	1680-3360	17	17.0
Poor	3360-5040	20	20.0
Non poor	>5040	59	59.0
Total		100	100

Source: Field Survey, 2014

Effect of Cassava Processing on Poverty Status of the Processors: From Table 6, the age and amount spent on feeding of the processors were statistically significant at 5% and 10% probability level, respectively but negatively related to the poverty status of the processors. This implies that the probability of the cassava processor living above poverty



line decreased with age and amount spent on feeding while the probability of the processors living above poverty line increased with increased in assets ( $p \leq 0.05$ ), quantity of cassava processed ( $p \leq 0.01$ ) and years of experience ( $p \leq 0.01$ ). This is in line with the study of [10] on cassava marketing and rural poverty among smallholder farmers in Southwest, Nigeria which revealed that age of the farmer is significant at 5% and has a negative sign. Implying that the older the farmer, the lower his probability of being poor. but contrary to the study of [14] on Analysis of poverty and its determinants among cassava farmers in Apa Local Government Area, Benue State, Nigeria which revealed that the co-efficient of age was positive to poverty implying that the older a farmer becomes, the more his poverty level increases. The value of household assets measures the ability of the household to withstand economic shocks and income shortfalls to finance the purchase of household needs. This result is in agreement with the findings of [3] study on in their study on estimating the determinants of poverty depth among the Peri-Urban Farmers in Nigeria which stressed that poverty depth is decreased by total value of asset increases by one unit. This is contrary to the findings of [14].

Table 6. Logit Regression Analysis of the Poverty Status of the Processors

Variables	Coefficients	Z	P >  Z
Quantity of cassava	0.0037021	3.10***	0.002
Health status	-0.02719704	-1.01	0.313
Age	-0.2013934	-2.42**	0.016
Years of experience	0.9732738	2.91***	0.004
Household size	0.3131291	1.35	0.178
Assets	0.0001115	2.35**	0.019
Amount spent on feeding	-0.0006928	-1.84*	0.065

Source: Field Survey, 2014 \*\*\* Significant at 1%, \*\* Significant at 5%, \* Significant at 10%

Table 7 shows the marginal effect and partial elasticity of the significant variables affecting the poverty status of the processors. The Table revealed that a 1% increase in the years of experience, value of assets and quantity of cassava processed resulted in 4, 446 and 0.01

percent increase in the probability of the processors living above poverty line, respectively. In addition, a 1% increase in age and amount spent on feeding reduced the probability of the processors living above poverty line by 0.8 and 0.003%, respectively. The results of partial elasticity revealed that quantity of cassava processed, years of experience, value of assets and amount spent on feeding were elastic, that is, a unit change in any of these variables caused a more than proportionate change in probability of living above poverty line whereas, a unit change in age resulted in less than a proportionate change in probability of living above poverty line.

Table 7. Marginal effect and partial elasticity of the significant variables affecting poverty status of the Processors

Variables	Marginal effect	Partial elasticity
Quantity of Cassava	0.0001481	10.24581
Age	-0.0080585	-2.904093
Experience	0.0389444	2.851692
Assets	4.460060	1.438043
Amount spent on feeding	-0.0000277	1.155534

Source: Field Survey, 2014

## CONCLUSIONS

The study was conducted on rural employment generation and poverty alleviation through small scale cassava processing ventures in Niger State, Nigeria. The result of the profit indicators showed that cassava processing was a profitable business venture and could be a source of livelihood for most rural dwellers, particularly women in the study area. Quantity of cassava processed, years of experience, transportation cost and storage cost were the main determinants of cassava processing in the area. In addition, the findings revealed that probability of the cassava processor living above poverty line decreased with age and amount spent on feeding while the probability of the processors living above poverty line increased with increased in assets, quantity of cassava processed and years of experience. The result of the marginal effect and partial elasticity of

the significant variables affecting the poverty status of the processors revealed that a 1% increase in the years of experience, value of assets and quantity of cassava processed resulted in 4, 446 and 0.01 percent increase in the probability of the processors living above poverty line, respectively. In addition, a 1% increase in age and amount spent on feeding reduced the probability of the processors living above poverty line by 0.8 and 0.003%, respectively. The results of partial elasticity revealed that quantity of cassava processed, years of experience, value of assets and amount spent on feeding were elastic, that is, a unit change in any of these variables caused a more than proportionate change in probability of living above poverty line whereas, a unit change in age resulted in less than a proportionate change in probability of living above poverty line. Based on the findings, it is recommended that processors should be provided with market to increase the sale of cassava products thereby enhancing profits made by processors and also, there is need for community based programmes organised by government and non-governmental organizations towards ensuring the continuous production and processing of cassava to its by-products by young and middle age group.

## REFERENCES

- [1] Adewumi, M. O., Ayinde, O. E., Olatunji, G. B., Ajayi, F. F., 2012, Effect of poverty on risk attitude of rural women investors in Osun State, Nigeria. *Journal of Agriculture and Social Research (Jasr)* 12(1):19
- [2] Amao, J. O., Adesiyani, O. I., Salako, B.A., 2007, Economic analysis of cassava processing into garri Pakistan *Journal of Social Sciences* 4(2):266-270
- [3] Asogwa, B. C., Umeh, J. C., Okwoche, V. A., 2012, Estimating the determinants of poverty depth among the peri-urban farmers in Nigeria. *Research Journal of Social Sciences* 4(3): 201-206
- [4] Edig, X., Schwarze, S., Zeller, M., 2013, Poverty assessment by proxy-means tests: Are indicator-based estimations robust over time? A study from central sulawesi, Indonesia. *Quarterly Journal of International Agriculture* 52, No. 1: 27-49
- [5] Federal Ministry of Agriculture and Rural Development (FMARD), 2011, Agricultural Transformation Agenda (ATA): we will grow Nigeria's agricultural sector.
- [6] Foster, J., Greer, J., Thorbecke, E., 1984, A class of decomposable poverty measures. *Econometrica* 52: Page 761-766.
- [7] International Institute for Tropical Agriculture, (IITA), 2004, Nigeria's Cassava Industry: Statistical Handbook. In *Global Cassava Development Strategy: A Cassava Industry revolution in Nigeria*. The potential for a new industrial crop 1- 11 Pp
- [8] Muhammad-Lawal, O., Omotesho, A, Oyedemi, F.A., 2013, An assessment of the Economics of Cassava processing in Kwara State. Thesis submitted to the Department of Agricultural Economics and Farm Management University of Ilorin, Ilorin, Nigeria.
- [9] National Population Commission (NPC), (2006). "National Population Commission Provisional results of the 2006 national population of human and housing census". Niger State Government [www.nigerstate.gov.ng](http://www.nigerstate.gov.ng) accessed October 2014
- [10] Obisesan, A., 2012, Cassava Marketing and Rural Poverty among Smallholder Farmers in Southwest, Nigeria *Bulletin of Environment, Pharmacology and Life Sciences Online* ISSN 2277 – 1808 Volume 1 (8), 29 – 34
- [11] Sanusi, W. A., 2011, Sanusi W.A (2011). Effect of poverty on participation in non-farm activity in Ibarapa Local Government Area of Oyo State. *International Journal of Applied Agricultural and Apicultural Research* 7 (1&2): 86-95
- [12] Suich, H., 2012, Conceptual Framework: Poverty. *Bulletin of Ecosystem Services for Poverty Alleviation (ESPA)*. (1):1-3
- [13] Yakubu, O. D., Aderonmu, A. J., 2010, Rural Poverty Alleviation and Democracy in Nigeria's Fourth Republic (1999-2009). *Current Research Journal of Social Sciences* 2(3): 191-195.
- [14] Tsue P. T. J., Obekpa, U. C., Iorlamen, T. R., 2013, Analysis of poverty and its determinants among cassava farmers in Apa Local Government Area, Benue State, Nigeria *Journal of Agricultural Economics and Development* Vol. 2(7), 296-300 Available online at <http://academeresearchjournals.org/journal/jaed> ISSN 2327-3151 ©2013 Academe Research Journals
- [15] United Nations Funds for Population Activities (UNFPA), 2009, [www.nigeria.unfpa.org](http://www.nigeria.unfpa.org) accessed October 2014

## **MEDICAGO SATIVA – FODDER-FOOD – NATURIST MEDICINE**

**Olimpia PANDIA<sup>1</sup>, Ion SARACIN<sup>2</sup>, Ion BOZGA<sup>1</sup>, Ștefania Eliza TANASIE<sup>3</sup>**

University of Agricultural Sciences and Veterinary Medicine, Bucharest, Romania, Faculty of Management, Economic Engineering in Agriculture and Rural Development, Slatina Branch, 150, Strehareti Street, Zip Code 0500, Slatina City, Olt County, Romania,  
Emails: olimpia\_pandia@yahoo.com; veterinary\_serv@yahoo.com

<sup>2</sup>University of Craiova, Faculty of Agriculture, 19, Libertatii, Craiova City, Romania,

Phone: +40251418475, E-mail: ion\_saracin@yahoo.com

<sup>3</sup>University of Medicine and Pharmacy, Craiova, E-mail: elyzuk\_elly@yahoo.com

**Corresponding author:** olimpia\_pandia@yahoo.com

### **Abstract**

*Medicago Sativa, also known as fodder for animals, has the propriety to increase the content of organic substance from the soil. After the biological, chemical and biochemical research on this plant, there was found an important/significant content of nutritive substances necessary for the human body and, used in various forms (as tea, juice, salads etc.), contributes in the same time as naturist medicine for human organism, or just in therapeutic forms for treating or improving diseases (as tinctures, capsules, powder etc.).sent the results obtained in order to determine the optimal moment for harvesting green leaves of Medicago sativa and the establishment of the maximum content in nutritive substances. Medicago sativa distinguished by the high content in enzymes, phytoestrogen, protein, Calcium, iron, magnesium, phosphorus, potassium, essential amino acids and vitamins C, B6, D, A, K and E (biologist Frank Bouer). Because the quantity of vegetal protein existing in the green leaves of the plant is higher than the one existing in the animal protein and the vitamin C is four times higher than in citrus (Gillian Mc Keith, 2008), the values of the two nutrients are determined in two different moments of leaf harvesting.*

**Key words:** evolution, milk production, NW Region, Romania, trends.

### **INTRODUCTION**

The medicine obtained naturally and their beneficial role for the human body are searched in old treatment recipes and naturist cures used for hundreds of years but forgotten through time, are rediscovered today by research and are people seek and use them more and more.

The completion of the nutritive substances necessary for the human body by day-by-day nutrition gives importance for the knowledge of other sources for obtaining them besides the known ones. [3].

Thus, besides the consumption of many plants, fruits and vegetables, *Medicago sativa* is studied and recommended by phytotherapists as a naturist medicine for treating and improving various diseases but also for the completion of the necessary of essential amino acids which cannot be synthesized by the human body and which are found in this plant in number of eight (Mc Keith, 2008).

The content in chlorophyll existent in *Medicago sativa* leaves has an anti-bacterial effect for the consumer and has a beneficial effect for the consuming organism by fortification of the immune system for elders, the decrease of cholesterol level and the prevention of cardiovascular diseases and myocardial infarction, if it is added in nutrition.

Also, the consumption of green leaves of this miraculous plant supports the fortification of osseous system and dentition at children.

The quantity of vitamin C existent in these leaves is four times higher than in citrus and the calcium is absorbed and assimilated easier by the organism, being the essential nutrient that every cell in the human body needs in order to resist, to be strong and healthy and which can be taken by consuming the leaves [1].

The plant is also used as general tonic and hardener for the immune system. The treatment with *Medicago sativa* is

recommended by specialists for detoxification and stimulation of liver function and purification of blood.

Due to its high content in fibers, the plant has the power to absorb and eliminate the toxins inside the body [2].

“In case of consuming the plant before meals, the gastro-intestinal functions are supported because it facilitates the release of gastric compounds which help the digestion.

Equally, it can support the assimilation of nutritive substances from aliments if consumed at the end of the meal”, [2].

Because the proteins are components of every cell in the organism, being involved in its every functioning process, it is very important to know the quantities of vegetal proteins existent in each aliment, because the daily necessary is 1g/body, depending on sex and age, and the *Medicago sativa* leaves have in their composition high quantities of protein (over 18.9% protein), compared to the animal proteins [4].

## MATERIALS AND METHODS

Research and studies were made in 2013 in the north of Oltenia, specifically in Grecești village, where favourable natural conditions exist. *Medicago sativa* improves soil fertility, being par excellence an ameliorative plant, and is the most extended culture existent in the area. It is used by people especially as fodder for animals, without being aware of its agro-technical value and its propriety of aliment and naturist medicine and without accounting the seed purity or the mandatory maintenance works, respectively weed control.

Therefore, the appliance of technology at alfalfa for seed is indicated for its usage as food and naturist medicine.

To realize the proposed objectives, we have taken in study a surface of 100 m<sup>2</sup> cultivated with alfalfa, where we have made the maintenance works for weed control in the spring and we harvested eight samples for each separate development moment, at the end of April and the beginning of May, specifically at the end of budding and the middle of blooming phase of the plant, for

determining protein and vitamin C from these plants.

The sample preparation for analysis is made in this way: before establishing the analyses program to be made, the plant leaves harvested before budding are carefully examined in order to be healthy and not to contain impurities (straws, soil particles), and numbered for each sample.

The work method for determining vitamin C (volumetric) in *Medicago sativa* leaves consist in: 5 g of fresh substance from the sample plant are milled and washed with 50 ml hydrochloric acid 2%, in 250 ml large glasses by filtering. 10 ml of extract are taken, 5 ml of IK 1%, 5 ml HCl 2%, 30 ml distilled water, 2-3 drops of starch. It is titrated with potassium iodate 0.001 n and a slightly blue solution results.

The results of the titration are multiplied by an 8.8 coefficient. The result is expressed in mg of ascorbic acid/100 g fresh substance/mg%.

Work method for determining the content in protein from *Medicago sativa* leaves was made on the principle of classical method Kjendal, where 1 g of vegetal material is weighed and introduced in a Kjendal balloon.

10 ml of concentrated H<sub>2</sub>SO<sub>4</sub> are introduced in the balloon and are left until the next day when the balloon is covered with a glass funnel and boiled for 4-5 hours.

When the liquid from the balloon has bleached (from black to light brown) the balloon is taken from the flame and left to cool for 20-30 minutes. After this, 4-5 ml of perhydrol are added. The mineralization is continued until the liquid becomes colorless.

The cooled solution is completed with distilled water and is passed through a 100 ml ranked balloon, and is brought to the sign. The obtained solution represents the nitrogen from the analysed plant which will be dosed by distillation and, after the nitrogen is calculated, the percent of gross protein from the analysed vegetal material is calculated by multiplying the N<sub>2</sub> total content calculated with a convert factor which represents the quantity of protein in grams which corresponds to a gram of nitrogen.

In this case, the calculated factor has a value

of 6.00.

$$\text{Protein} = \text{Nt} \times f \quad (1)$$

Where:

Nt – represents the total nitrogen from the analyzed plant

f – the convert factor

## RESULTS AND DISCUSSIONS

The effectuated analyses and the obtained results are shown in the tables down, these being harvested in two different methods, eight samples each.

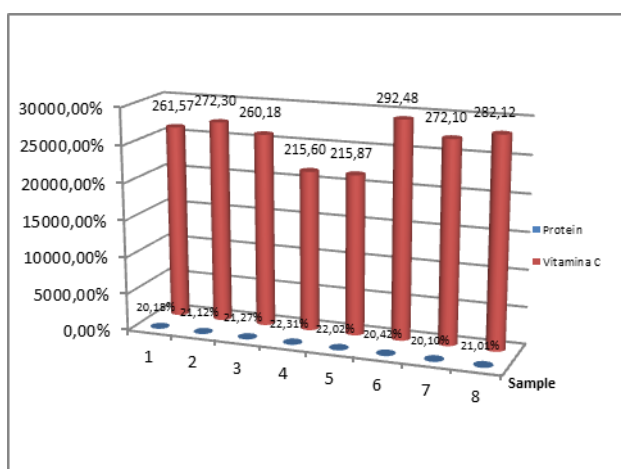

Fig. 1. Determination of protein and vitamin C during budding

Source: Own determination.

From the results obtained after determinations it was found that the higher percent of protein is in the leaves harvested at the end of blooming (22.31%), which leads to the assumption that the harvest of *Medicago sativa* leaves in this period is very good, so that they can be used at their maximum yield both as food and medicine. The vitamin C has significant values (292.48 mg of ascorbic acid) and the consumption of these leaves in green state is a new source of nutritive substances needed by our organism.

After making the determination for the second moment (the plant blooming one), the results obtained for the two determinations are positive, but the alfalfa leaves are richer in vitamin C in this period, having values comprised between 230.57 and 291.03 mg of ascorbic acid and the protein has the highest value of 20.08%.



Photo 1, 2, 3, 4. *Medicago sativa* harvested plants for making determinations

Source: own results



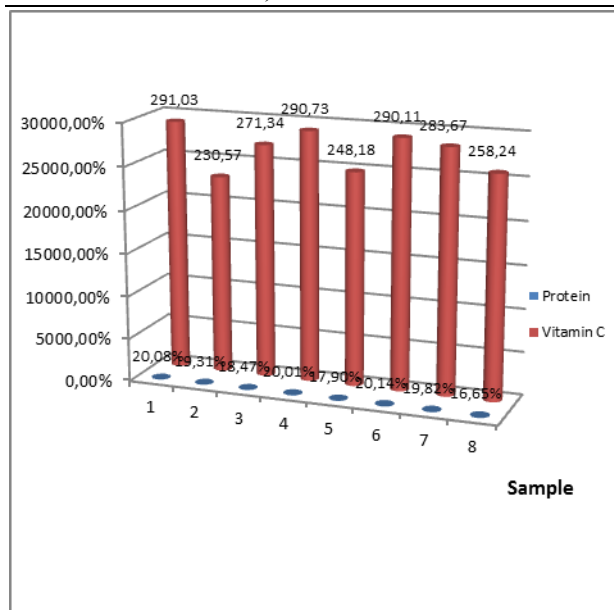

Fig.2. Determination of protein and vitamin C during blooming

Source: Own determination.

## CONCLUSIONS

The results obtained by biochemical determinations are necessary materials which will make the study object for obtaining naturist products which have as active substance components obtained from alfalfa leaves, being known that the replacement of chemical-obtained products with naturist ones is tried with success.

The researchers continue the studies and put into practice the obtained results for the promotion of naturist products both in alimentation and naturist medicine as well as in beauty industry.

The studied active principles obtained from these leaves are more efficient, even if they act slower, being easy to procure on a larger period of time, cheaper and at hand for people who want raw alimentary supplements, drugs and naturist treatments.

## ACKNOWLEDGEMENTS

*Medicago sativa* can be a sure source of profit for many commercial entrepreneurs who can transform the known fodder plant in alimentary supplements and naturist products as tea, tinctures, powders, capsules.

## REFERENCES

- [1]Giurgiu O., Giurgiu C., 2005, Medicinal plants important in naturist treatments.
- [2]Mc.Keith Gillian, 2008, Living food for health. ISBN: 978-973-669-592-6.
- [3]Pârnu, C., 2003, The encyclopedia of plants. Technical Publishing, Bucharest.
- [4]WHO, 1999, Monographs on selected medicinal plants. vol. I, Radix Glycyrrhizae.

## THE IMPACT OF INVESTMENT MANAGEMENT ON THE EVOLUTION OF THE AGRI-FOOD EXPORT IN THE REPUBLIC OF MOLDOVA

Svetlana PETRASCU

State Agrarian University of Moldova, 44 Mircesti str., 2049, Chisinau, R. Moldova, Phone: +373.22.432.136, Mobile:+373 69581003, Email: s.sasu@uasm.md

**Corresponding author:** s.sasu@uasm.md

### **Abstract**

*The investment represents a sequence of actions due to which certain available, redundant or attracted resources are transformed into concrete goods in order to obtain future effects in form of advantages, but mainly in the form of profit. Investment Management acts as a support for the sustainable development of Moldova's economy. Over the years, the Republic of Moldova was considered as a major supplier of agri-food products. Unfortunately, intensive exploitation of agricultural lands, transition process, negative impact of the global financial crisis and embargoes imposed by Russia drastically reduced the agri-food products exports. Being a country with small economy and scarce reserves for growth and in order to ensure a high development level, Moldova should focus on the export activity. Therefore, as the export represents an economic effect, it records a better increase through the use of investments. It is well known that in order to increase production efficiency, to attract new technologies and to produce value-added goods, local companies have to orient themselves to foreign markets. At present, the exports are mainly focused on the investment opportunities.*

**Key words:** agri food, economy, export, investment, foreign markets

### **INTRODUCTION**

Developing of a competitive and effective economy in our country depends on ensuring favorable conditions of work for manufacturers, stimulating the export of domestic products and attracting investment. [5] To increase efficiency in production, attraction of new technologies, production of goods with high added value, Small and Medium Enterprises have to turn to foreign markets. Unfortunately, agricultural farms have difficulties regarding the export of agricultural products. One of the factors that slow the growth of export continues to be a lack of access to finance. The attraction of investments in the economy of any country fits into a competitive game led to progress more favorable conditions to foreign investors.[6] International experience has shown that in order to ensure minimum conditions for attracting foreign investors it should be a legislative framework in the field of investment and economic functioning, transparent, permanent and predictable. Also the ability to attract foreign capital is represented by openness of the economy to

foreign investors and the public and political parties attitude towards foreign investment. [4] Although the share of agricultural investment in total investment in Republic of Moldova has increased lately, this increase is not enough to stop the depreciation of agricultural assets.

### **MATERIALS AND METHODS**

The reflected researches were achieved on informational materials of the National Bureau of Statistics of the Republic, the National Bank, Ministry of Agriculture and Food industry, Ministry of Finance, etc. There were used the following research methods: monographs, comparison, analysis, inference.

### **RESULTS AND DISCUSSIONS**

Accordingly to the strategy of attracting investment and promoting exports for 2006-2015, the joint policy of attracting investment to the export promotion creates a strong premise to ensure the further economic growth and raising the generation welfare of the people. [10] There is a strong correlation

between the export value of the one of the economic sector and the number of foreign-owned companies operating in that sector. [2] In order to create a clearer impression about the contribution of investment to the development of agri-food exports in the Republic of Moldova, first we wanted to make an analysis of the main macroeconomic indicators of the Republic of Moldova.

Table 1. The evolution of the macroeconomic indicators of the R. Moldova in the period 2008-2013

Indicators	2008	2009	2010	2011	2012	2013
GDP in current price mil. lei	62,921	71,885	72,897	82,349	88,228	100,312
GDP as compared to the previous year, %	107,8	94,0	107,1	106,4	99,3	113,7
Investments in long term tangible assets, compared to the previous year, %	102,3	66,5	116,5	109,3	101,5	100,2
Balance of goods and services ,PIB, %	-53,1	-36,6	-38,6	-40,4	-40,0	-37,2
Average propensity to export %	41,1	36,8	39,1	44,7	43,0	43,4
Average propensity to import, %	94,2	73,4	77,6	85,2	83,0	80,6
Import penetration rate, %	61,5	53,7	56,0	60,7	59,3	58,7
Export / import, %	43,6	50,1	50,0	52,2	41,5	45,3
The net flow of FDI per capita	199	41	55	77	49	60,0
External debt at end of the year, mil.USD	4079,3	4327,08	4711,10	5358,91	6019,82	6673,37
External debt/ PIB, %	67,4	79,6	81,0	76,4	82,6	83,8

Source: Elaborated on the date presented by National Bank of Moldova and National Bureau of Statistics.

According to the table 1 we can mention, that GDP increased in 2013 compare to 2012, with 13.7% and compare to 2008 with 59.4%. If we analyze the dynamics of development, then we can mention that it has a tendency practically fix, growing. The value of exports covers only the value of imports in 2013 amounting to 45.3%. Compare to 2012, it has a tendency to increase, but compared to 2010 it decreased by 6.9%. The Income flow of direct net investment recorded the highest value and size reaches 199 dollars per capita in 2008. The value of this indicator has drastically in 2009 - 41 dollars per capita. In 2013 the size of this indicator is 60 dollars per capita. Based on the results shown in Table 1, we conclude that the dynamics of the main macroeconomic indicators of the Republic of Moldova in 2013 have a positive trend. Mostly, this subject was conditioned by the economic policies, undertaken by the Government of the Republic of Moldova. At

the same time continues to increase the value of indicators related to external debt and its share of GDP. As seen from the data presented, the situation is unsatisfactory. It is known that, as the country attracted a large volume of foreign investments the exports per capita have increased and in the same time increased and living standards expressed as GDP per capita at purchasing power parity. [7]

Analyzing the foreign trade of the Republic of Moldova in the period 2008- 2013 is noticed a growing trend, but more modest pace than imports. Being an agricultural country, Moldova's exports mainly focuses on three product categories - food, drinks, fruits and vegetables. [1] Experience shows that the appearance, dimensions and packing of our goods are less competitive not only in the West but on the CIS markets also, being under the standards of other manufacturers.[5] In addition, on the same markets Moldova has to compete with other countries from Eastern Europe that have free trade agreement with the European Union.

Next we perform the analysis of food products trade balance of Moldova.

Table 2.The dynamic of the commercial balance of the trade with agri-food of Republic of Moldova, in the period of 2009-2013, thousand dollars

	YEAR				
	2009	2010	2011	2012	2013
COMERCIAL BALANCE- total, th. \$ USA	-1995,2	-2313,8	-2974,5	-3051,3	-3064,1
which:					
Animal	-7,7	4,4	2,4	1,1	-1,5
Meat and edible meat	-12,0	-17,3	-9,3	-20,2	-26,8
Dairy products and eggs	-16,7	-20,3	-23,7	-30,2	-35,5
Fish	-29,1	-33,3	-37,3	-41,7	-43,5
Vegetable	-20,8	-21,4	-13,6	-16,8	-19,9
Fruit	85,2	109,6	118,5	133,6	136,9
Cereals	57,0	61,3	61,9	-23,9	108,1
Products of the mill ale industry	-24,8	-25,7	-37,0	-40,2	-35,9
Sugar and sugar confectionery	20,4	16,5	-8,4	4,3	-7,1
Coffee, tea	-7,9	-9,1	-11,0	-10,8	-11,7
Beverages	111,6	133,2	131,0	146,7	176,2
Tobacco and manufactured tobacco	-72,5	-64,3	-64,2	-48,8	-50,653

Source: established on data base presented by Trade Map.

[http://www.trademap.org/Product\\_SelCountry\\_TS.aspx](http://www.trademap.org/Product_SelCountry_TS.aspx)

Accordingly to the data presented in Table 2



we can mention that the trade balance of Republic of Moldova, in 2009 to 2013, has a tendency to increase and amounted in 2013 - 3064100. US dollars. Compared to 2012, it increased by 0.5% and compared to 2009, it increased by 53.6%. This speaks of the fact that imports grew faster compared to Moldovan exports in the period.

Attracting FDI requires the prior existence of conditions of political, economic, legislative, without which any policies are meaningless.

The first element is the basic legislation and economic investment: it is necessary to provide at least a minimal framework on companies, competition, insolvency, insurance, accounting system and others. The existence of these regulations is necessary, but not sufficient.[8]

Complementary aspect refers to the degree of effective implementation of legislation and the functioning of the market economy institutions. The international experience has shown that only countries that have created a functional framework of the market economy are attractive to foreign investors.

So, to ensure minimum conditions for attracting foreign investors, institutional and economic legislation must exist, to be functional, to be transparent, fixed and predictable.

A second aspect of the capacity of attracting foreign capital is the openness of the economy to foreign investors. Countries that have opened completely the economy, allowing by compliance with technical regulations, environmental protection, etc., access to investors in all fields, have attracted more foreign investors. On the other hand, the countries which have excluded from the field of access some sectors, which were considered strategic, or those that allowed privatization of public utilities (telecommunications, energy, water) had registered low levels of foreign investment.

Another general aspect is the population attitude and political parties to foreign investment. It is obvious, that in case of a hostile attitude to foreign investors, both in the population level as well in the level of political parties, foreign investors will be discouraged and will avoid acting on that

market.

In general, there are 3 types of factors which influence the investment decisions:

- a.investing firm-specific factors;
- b.location factors;
- c.political factors - administrative and legislative.

Creating a favorable investment climate is the main condition for attracting foreign investment in agri-industrial sector. In practice, this would mean that agribusiness is attractive first of all for local investors. Taking into consideration, it is necessary to elucidate the main positive factors favoring investment flows opposite to those unfavorable. As well we must emphasize the main opportunities and threats in the investment activity, particularly in the agricultural sector of the country.

Table 3. The dynamic of foreign direct investment in Republic of Moldova (mil.USD)

	2010		2011		2012		2013	
	inflow	outflow	inflow	outflow	inflow	outflow	inflow	outflow
FDI	358.62	154.23	440.10	172.46	374.64	199.35	371.27	163.85
Abroad	0.09	3.60	0.04	20.61	0.41	20.19	0.21	29.09
In national Economy	358.53	150.63	440.06	151.85	374.23	179.16	371.06	134.76
Social capital	186.33	29.35	187.24	43.34	210.12	65.57	185.97	25.65
Bank sector	34.03		7.64		12.21	18.60	32.64	7.48
Other sectors	152.30	29.35	179.60	43.34	197.91	46.97	153.33	18.17
Reinvestment	14.55		86.72		-11.01		19.20	
Bank sector	-24.66		10.91		5.26		8.81	
Other sectors	39.21		75.81		-16.27		10.39	
Other capital	157.65	121.28	166.10	108.51	175.12	113.59	165.89	109.11
Debts to foreign investors	2.71	6.80	7.27	20.48	0.03	9.83	5.62	18.36
Engagements to foreign investors	154.94	114.48	158.83	88.03	175.09	103.76	160.27	90.75

Source: Elaborated on the date presented by National Bank of Moldova and National Bureau of Statistics.

In 2013, the direct investment amounted to a net outflow of 207.42 million USD, up to 18.3 percent over the previous year. The flow of foreign direct investment of the citizens of Moldova was EUR 28.88 million USD net during 2013, which represents an increase of 46.0 percent compared with 2012.

Indisputable, Moldova agriculture is the main branch of the economy, which is why it is considered as the strategic national priority. Although we can talk about a fairly advanced stage of promoting reforms in this sector now, it seems, however, that the roller destruction left deep traces in highly technological systems and equipment, as well in the

management and finance. [9]

Investment climate in Moldova for Foreign Direct Investment can be presented as follows:

- Stability of economic policies;
- Facilities investment;
- Laws and regulations that support the development of entrepreneurship;
- Support effective to service delivery activities.

## CONCLUSIONS

Analysis of Foreign Trade in agricultural products leads us to the conclusion that every country must develop the real sector for trade promoting and investment. Without dynamic enterprises, no country can take advantage of trade and investment opportunities. Enterprises need access to finance, technology and business services. It is therefore important to create favorable conditions for entrepreneurs, especially for those that produce goods for export. Particularities of facilities for domestic and foreign investors should be closely linked to the guaranteed right for business achieving. Any investment is made in order to obtain further profit. This is about the ability to export, focus and smooth put of value. It is important that the state does not discriminate the foreign and domestic investors in the application of facilities. In principle country equally needs these investments.

Among the factors that remove investors, experts indicate corruption, excessive state control, poor infrastructure and the Transnistrian conflict.

## ACKNOWLEDGEMENTS

The article was produced as part of the state project “The sustainable development of the rural area of the Republic of Moldova in the prospect of EU”

## REFERENCES

[1]Agriculture and agri-food industry of the Republic of Moldova, 2011. Publication of the Ministry of Agriculture and Food Industry. Chisinau.

[2]Cimpoies Dragos, Aurelia Litvin,2013, Exportul Productiei horticole, Ghid practice, Chisinau

[3]Dragan G., Zaharia R., 2000,International Economic Relations, ASE Bucuresti.

[4]Impactul investitiilor straine directe asupra economiei Republicii Moldova, 2010. Studiu economic, Chisinau.

[5]Litvin Aurelia, 2011, Management and regulation of food exports from Moldova, Scientific theoretical journal of Economy and Sociology, 1.

[6] Litvin Aurelia, Sasu Svetlana, 2014, Credit projects impact on agricultural individual sector development in Moldova. Series "Management, Economic Engineering in Agriculture and rural development", Vol. 14(2).

[7]Miron D., 2003, International trade, ASE, Bucuresti

[8]Report of the Executive Credit Line of the Ministry of Finance of Moldova for 2012

[9]Study produced under the project “Capacity building of national platforms from Civil Society Forum of the Eastern Partnership”, 2013, Chisinau

[10]Strategy for attracting investment and export promotion for 2006-2015

## ASSESSMENT OF GROUNDWATER QUALITY FROM BAIJA MARE MINING AREA, ROMANIA

Ioana PIȘTEA, Cristina ROȘU, Carmen ROBA, Alexandru OZUNU

“Babeș Bolyai” University, Faculty of Environmental Science and Engineering, 400294 Cluj-Napoca, Romania, Email: cristina.rosu@ubbcluj.ro

**Corresponding author:** cristina.rosu@ubbcluj.ro

### Abstract

Baia Mare mining area is one of the most important mining areas from our country. Even if all the mines were closed in 2007 they continue to pollute the environment. In the present study, the water quality from 14 groundwater sources from Baia Mare was investigated. The water sources are located in both rural and urban areas. The samples were collected in March 2014. A portable multiparameter (WTW 320i) and portable turbidimeter (WTW pPhotoFlexTurb) were used in order to measure in situ the following parameters: pH, total dissolved solids (TDS), electrical conductivity (EC), temperature, oxidation-reduction potential (ORP), salinity and turbidity. In laboratory, the water samples were analyzed by ion chromatography (DIONEX ICS-1500 system) in order to quantify the following dissolved ions: lithium ( $Li^+$ ), sodium ( $Na^+$ ), potassium ( $K^+$ ), magnesium ( $Mg^{2+}$ ), calcium ( $Ca^{2+}$ ), ammonium ( $NH_4^+$ ), fluoride ( $F^-$ ), chloride ( $Cl^-$ ), bromide ( $Br^-$ ), nitrite ( $NO_2^-$ ), nitrate ( $NO_3^-$ ), phosphate ( $PO_4^{3-}$ ) and sulfate ( $SO_4^{2-}$ ). The laboratory analyses indicated that the waters had a low mineralization and low concentrations of dissolved ions. We calculated the sodium adsorption ratio (SAR) to see if these groundwaters can be used in agriculture. The SAR values ranged between 0.01 and 4.61, being considerably lower than 10, which mean that all the groundwater samples can be classified as excellent waters. As a consequence they can be safely used in agriculture purposes.

**Key words:** Baia Mare, mining area, groundwater, major dissolved ions, sodium adsorption ratio

### INTRODUCTION

In the last decades groundwater pollution has become an increasing problem.

Mining activities have an important negative impact on environment because during mining operations (exploitation, ore processing) are produced wastewater, mine tailings and a lot of dust which contains a great amount of heavy metals. [14], [3], [6]

The formation of acid mine drainage is the biggest environmental problem associated with mining activities.

It is a slow process and it continues even after the mining operations were closed and it can affect the air, soil, surface water and groundwater, as well. [8]

The present study was conducted in Baia Mare town, seat of Maramures County, located in the western part of Romania, in Baia Mare Depression, on the middle of the Săsar River, at the foot of Igriș Mountains. [2], [4]

Baia Mare is one of the most important mining areas from our country; it is an

important centre of Romanian non-ferrous metallurgy (gold-silver ores, copper, lead, zinc).

The mining activities developed in Baia Mare for over 100 years led to water, soil and air pollution. [5]

We have chosen this area because even the mining activities (extraction, processing and preparation) were closed in 2007 they left behind tens of tailings dumps and tailing ponds which are located near settlements (Fig. 1).



Fig. 1. Study area with sampling points  
Source: Google Earth

**MATERIALS AND METHODS**

Drinking water samples were collected, in March 2014, from various part of Baia Mare mining area. They have been taken from 11 private wells and 3 natural springs.

Using a portable multiparameter WTW INOLAB 320i respectively a portable turbidimeter WTW pHotoFlexTurb we determine the physico-chemical parameters like: pH, temperature, redox potential, electrical conductivity, total dissolved solids, salinity, dissolved oxygen and turbidity. Those determinations were done *in situ* because the physico-chemical parameters values can be changed by climate conditions.

Water samples were stored in fridge and were analyzed for major dissolved ions in 24 hours after sampling. The major dissolved ions like: lithium (Li<sup>+</sup>), sodium (Na<sup>+</sup>), potassium (K<sup>+</sup>), magnesium (Mg<sup>2+</sup>), calcium (Ca<sup>2+</sup>), fluoride (F<sup>-</sup>), chloride (Cl<sup>-</sup>), bromide (Br<sup>-</sup>), nitrite (NO<sub>2</sub><sup>-</sup>), nitrate (NO<sub>3</sub><sup>-</sup>), phosphate (PO<sub>4</sub><sup>3-</sup>) and sulphate (SO<sub>4</sub><sup>2-</sup>) were determined using a ion chromatograph (DIONEX ICS1500).

Sodium content is an important factor in irrigation water quality assessment. The sodium adsorption ratio (SAR) was calculated is order to assess the possibility to use these waters in agricultural purposes. SAR influences the infiltration rate of water.

SAR was calculated using the sodium, calcium and magnesium concentrations (where all ionic concentrations are expressed in milliequivalent per liter) using the following equation. [7], [1], [11]

$$SAR = \frac{Na^+}{\sqrt{\frac{Ca^{2+} + Mg^{2+}}{2}}}$$

Table 1. Water classification based on SAR values

Sodium adsorption ratio (SAR)	Status
<10	Excellent
10-18	Good
18-26	Doubtful
>26	Unsuitable

Source: [12]

%Na was calculated using the sodium,

calcium, magnesium and potassium concentrations (where all ionic concentrations are expressed in milliequivalent per liter) using the following equation:

$$\%Na = \frac{(Na^+ + K^+) \times 100}{Ca^{2+} + Mg^{2+} + Na^+ + K^+}$$

**RESULTS AND DISCUSSIONS**

The results are presented in Fig. 2 – 4.

As we can notice in Fig. 2, 36% from samples have a pH value below the minimum permissible limit, they are slightly acidic. Regarding the ORP values 21.4% from drinking water samples have a negative value that indicates a reducing medium while 78.6% have a positive ORP values that indicates an oxidizing medium.

None of the drinking water samples exceeded the maximum permissible limit for **electrical conductivity** according to Romanian Drinking Water Law (Law 458/2002).

In terms of **total dissolved solids** in Romania we do not have a maximum permissible limit but regarding the US-EPA limit we can notice that one drinking water samples had a value above 500 mg/L. Total dissolved solids affect water clarity and the water balance in the cells of aquatic ecosystems.

In terms of **salinity**, as we can see in Fig. 2, two drinking water samples (S9 and S13) exceeded the maximum permissible limit imposed by US-EPA. S13 sampling point is a pump and S9 sampling point is a private well downstream of Herja Mine, near Herja creek. In Herja creek all mine waters from Herja mine are discharged without being treated. The water from these sources is used for drinking, cooking and irrigation. Salinity can include hundreds of different ions and high levels of salinity can destroy fertile agricultural land, can damage crops and can directly affect the plant growth.

The **turbidity** can be definite as the amount of cloudiness in the water. It is very important to measure the groundwater turbidity because a high turbidity can fill the pipes with mud and silt especially during the rainy season. [15], [16]

A high turbidity in drinking water is an aesthetic problem and it can also represent a health concern because it can provide food

and shelter for pathogens.

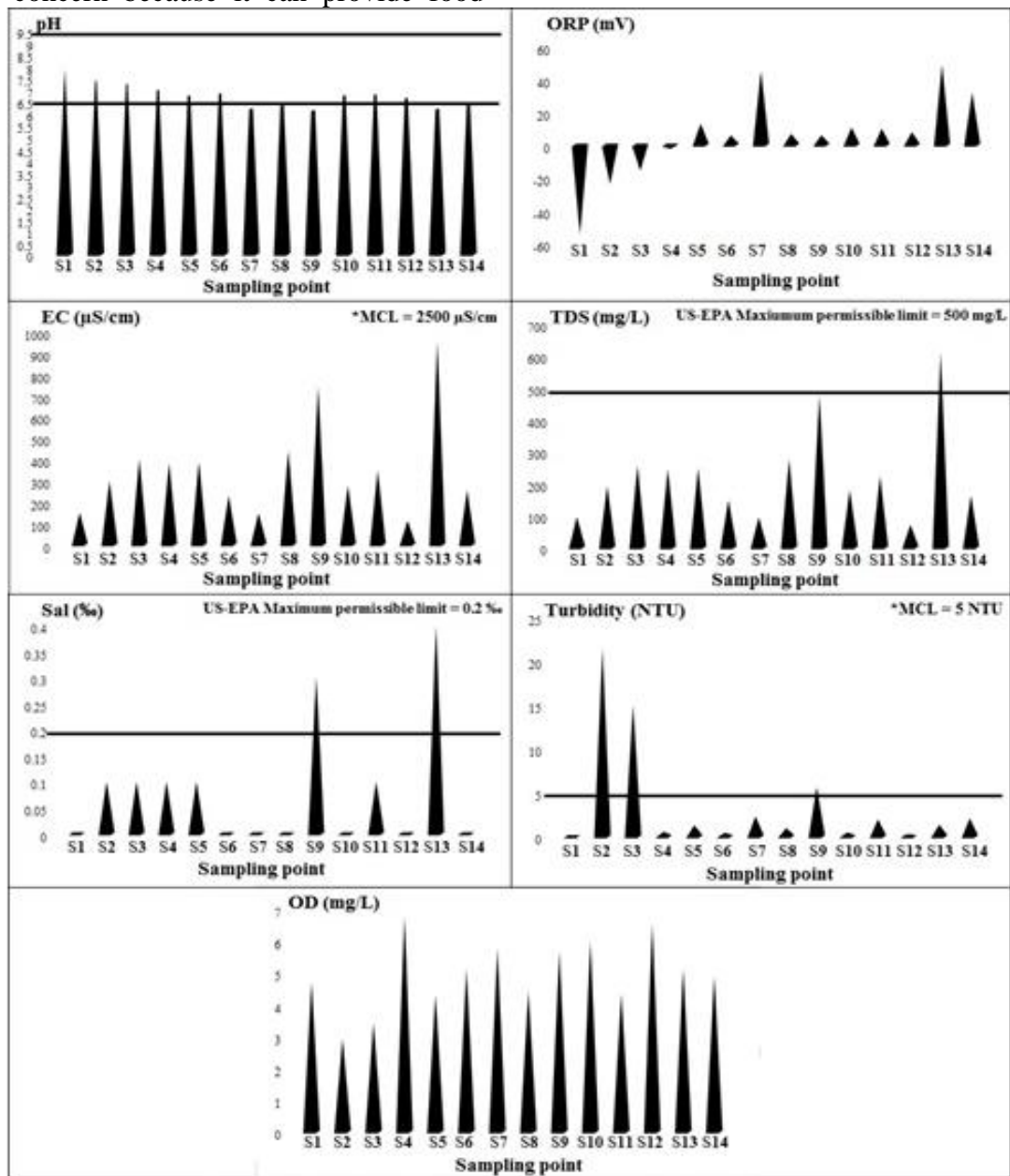

\* MCL - maximum concentration limit, from Low no. 458 - 08/07/2002 regarding the quality of drinking water

Fig. 2. The physico-chemical parameters values  
 Source: Own calculation.

As can be observed in Fig. 3 none of collected drinking water samples has a **sodium** concentration above the maximum concentration level required by Romanian drinking water law (Law 458/2002). Sodium does not have negative effects on human health; more than an adequate level of sodium are required for a good health. In Romania we do not have a maximum permissible concentration regarding the potassium,

magnesium, calcium and lithium. As we can see in Fig. 3, S3 sampling point has the highest **potassium, calcium** and **magnesium** concentrations. This drinking water was collected from a private well which is near the Tăuții de Sus tailing ponds. The water from the well is used for drinking, coking and for watering the plants. Calcium and magnesium are the most common sources of water hardness and they are essential

elements for plants growth.[10]  
 In general potassium is a nutrient for plants at low concentrations; a high potassium concentration can indicate the presence of pollution from fertilizers or other contaminants.

**Lithium** was found in 42.8% from drinking water samples. It doesn't occur naturally as a pure element, it occurs in salts and stable minerals. [9]

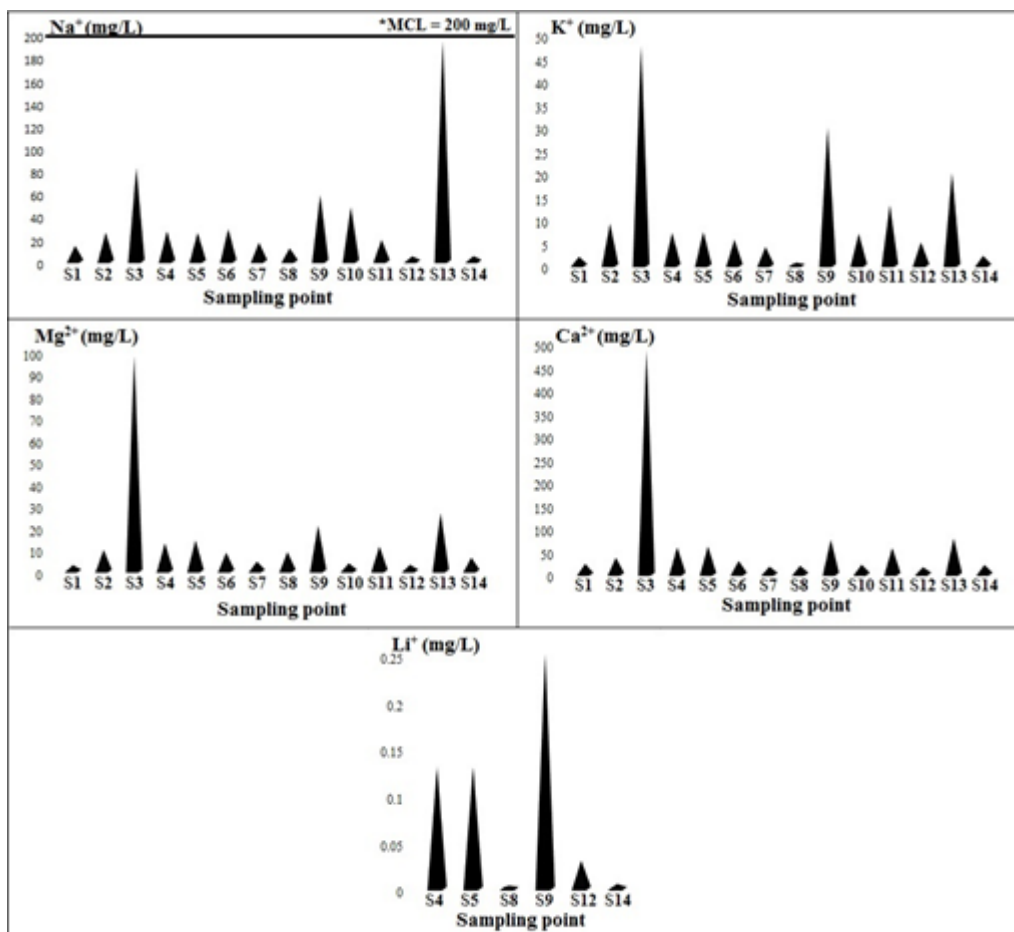

\* MCL - maximum concentration limit, from Low no. 458 - 08/07/2002 regarding the quality of drinking water

Fig. 3. The level of major dissolved cations  
 Source: Own calculation.

Regarding the **fluoride** and **nitrate** concentration, S9 sampling point exceeded the maximum concentration level imposed by Romanian legislation. Fluoride has negative health effects especially on bones. Fluoride can be absorbed by plants via their roots and after this it is store in their leaves. If the plant is sensitive to chloride can appear toxic symptoms (scorching or abscission of leaves). Nitrate is a naturally occurring form of nitrogen found in soil and nitrogen is an

essential nutrient for plant growth. As it can be seen in Fig. 5, SAR has the values between 0.01 (S3) and 4.61 (S10). 92.85 % from collected groundwater samples have a value below 3 what means that it is no threat to vegetation and these groundwater sources can be used safely as irrigation waters. Sampling point S10 has the highest SAR value. It may be due to the fact that this point is located near Herja mine.



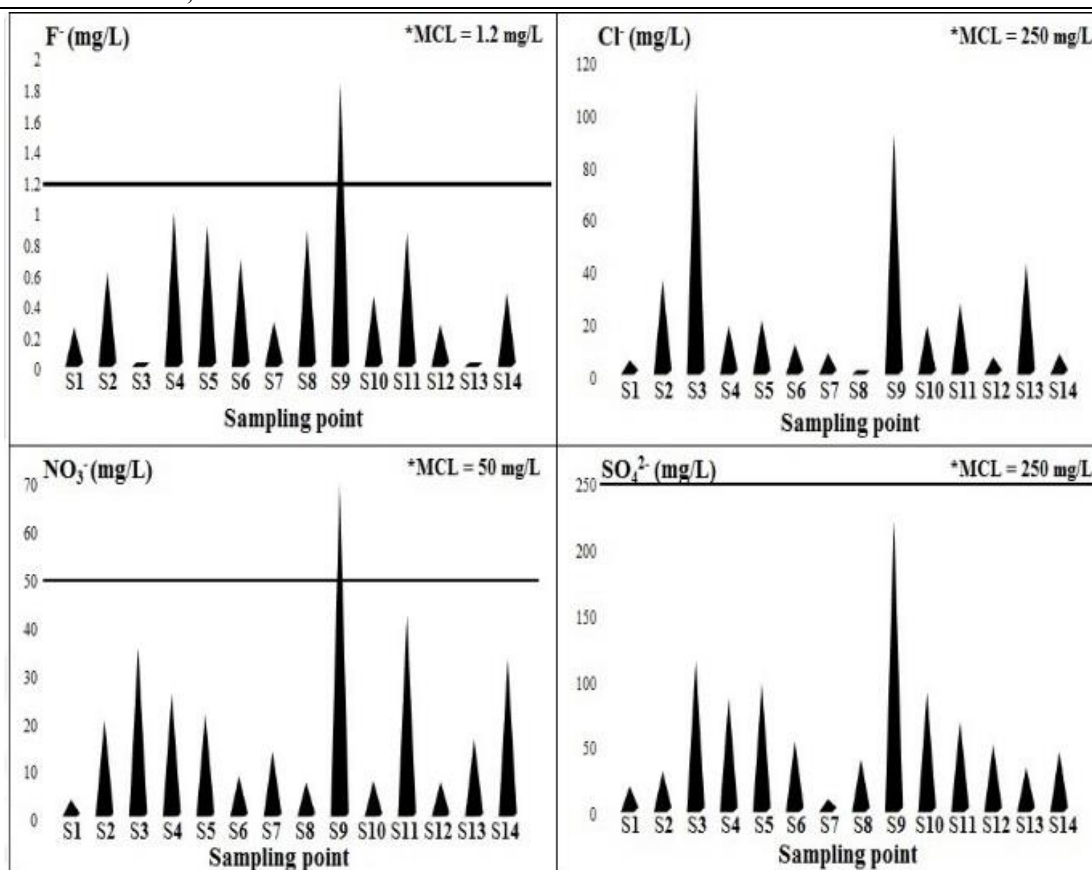

\*MCL - maximum concentration limit, from Low no. 458 - 08/07/2002 regarding the quality of drinking water

Fig. 4. The level of major dissolved anions  
 Source: Own calculation.

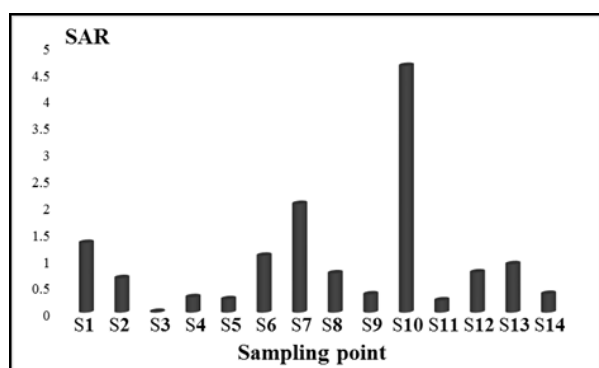

Fig. 5. The level of sodium adsorption ratio (SAR) for the groundwater samples  
 Source: Own calculation.

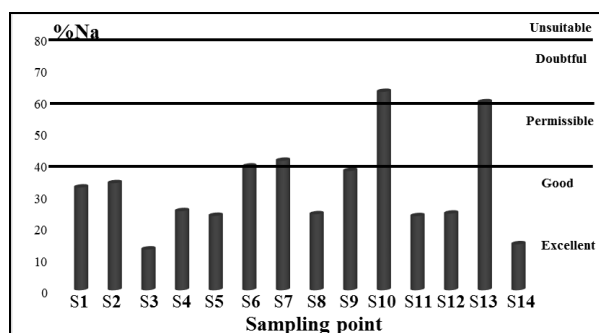

Fig. 6. The percent of Na for the groundwater samples  
 Source: Own calculation.

Based on %Na, 71.4% of the investigated groundwater sources belong to the excellent category, 14% belong to permissible category and 14% from samples belong to doubtful category (Fig. 6). [13]

## CONCLUSIONS

S3 sampling point has the highest potassium, calcium and magnesium concentrations. This groundwater was collected from a private well which is near the Tăuții de Sus tailing ponds. The water from the well is used for drinking, coking and for watering the plants. While the highest lithium, fluoride, nitrate and sulfate concentrations were determined in S9 sampling point. S9 sampling point is a private well downstream of Herja Mine, near Herja creek. In Herja creek all mine waters from Herja mine are discharged without being treated.

Regarding the SAR values and Na percentage almost all collected water sources may be used as safe source of irrigation.

## ACKNOWLEDGEMENTS

This paper is a result of a doctoral research made possible by the financial support of the Sectorial Operational Programme for Human Resources Development 2007-2013, co-financed by the European Social Fund, under the project POSDRU/159/1.5/S/133391 - "Doctoral and postdoctoral excellence programs for training highly qualified human resources for research in the fields of Life Sciences, Environment and Earth".

## REFERENCES

- [1] Abdul, H., M., Jawad, A., Mukheled, A., A, Abass, J., K., Athmar, A., M., 2010, Evaluation of Treated Municipal Wastewater Quality for Irrigation, *Journal of Environmental Protection*, Vol. 1: 216-225
- [2] Bălănescu, S., Achim, V., Ciolte, A., 2002, Management history mining, non-ferrous and precious in northwestern Romania, Gutinel Press, Baia Mare
- [3] Cassella, R., J., Wagener, A., L., R., Santelli, R., E., Wagener, K., Tavares, L., Y., 2007, Distribution of copper in the vicinity of a deactivated mining site at Carajás in the Amazon region of Brazil, *Journal of Hazardous Materials*, Vol. 142: 543-549
- [4] Damian, F., Damian, G., Lăcătușu, R., Macovei, G., Iepure, G., Năprădean, I., Chira, R., Kollar, L., Rață, L., Zaharia, D., C., 2008, Soils from the Baia Mare zone and the heavy metals pollution, *Carpathian Journal of Earth and Environmental Sciences*, Vol. 3(1): 85-98.
- [5] Filip, S., 2008, Depresiunea și Munceii Băii Mari. Studiu de geomorfologie environmentală, Presa Universitară Clujeană, Cluj-Napoca
- [6] García-Lorenzo, M., L., Pérez-Sirvent, C., Molina-Ruiz, J., Martínez-Sánchez, M., J., 2014, Mobility indices for the assessment of metal contamination in soils affected by old mining activities, *Journal of Geochemical Exploration*, in press
- [7] Harront, W., R., A., Webster, G., R., Cairns, R., R., 1983, Relationship between exchangeable sodium and sodium adsorption ratio in a solonchic soil association, *Can. J. Soil Sci.*, Vol. 63: 461-467.
- [8] Jürg, Z., Walter, G., 2013, Mining and the environment, *Environ Sci Pollut Res*, Vol. 20: 7487-7489.
- [9] Lynn, A., K., Arthur, J., S., 2003, Review of Lithium in the Aquatic Environment: Distribution in the United States, Toxicity and Case Example of Groundwater Contamination, *Ecotoxicology*, Vol. 12: 439-447.
- [10] Pallav, S., 2013, Potential health impacts of hard water. *International Journal of Preventive Medicine*, Vol. 4(8): 866-875.
- [11] Sisir, K., N., Anindita, L., 2012, Hydrochemical Characteristics of Groundwater for Domestic and Irrigation Purposes in Dwarakeswar Watershed Area. *India American Journal of Climate Change*, Vol. 1: 217-230.
- [12] Sudhakar, A., Narsimha, A., 2013, Suitability and assessment of groundwater for irrigation purpose: A case study of Kushaiguda area, Ranga Reddy district, Andhra Pradesh, India. *Advances in Applied Science Research*, Vol. 4(6): 75-81.
- [13] Wilcox, L., V., 1955, Classification and use of irrigation waters, Publisher: U.S. Department of Agriculture, Washington, D.C
- [14] Yu, L., Wang, Y., Gou, X., Su, Y., Wang, G., 2006, Risk assessment of heavy metals in soils and vegetables around non-ferrous metals mining and smelting sites, Baiyin, China. *Journal Of Environmental Sciences*, Vol. 18(6): 1124-1134.
- [15] www.epa.gov Accessed on December 2014
- [16] www.who.int Accessed on December 2014



## THE EVOLUTION OF EXPORT AND IMPORT PRICES IN REPUBLIC OF MOLDOVA AND THEIR EFFECT ON THE ECONOMIC GROWTH

**Daniela POPA**

State Agrarian University of Moldova, 44, Mircesti St., MD – 2049, Chisinau, Republic of Moldova, Phone: +373 795 74 780, Fax: (+373 22) 31-22-76, Email: d.popa@uasm.md

**Corresponding author:** d.popa@uasm.md

### **Abstract**

*The paper has been intended to analyze evolution of export and import prices in Republic of Moldova. The study was focused on dynamics of imports and exports in Moldova and their influence on economic growth. The data has been provided by the National Statistics Institute (INS), and the Ministry of Agriculture from Moldova Republic. According to preliminary data presented by the National Statistics Office, GDP in 2013 amounted to 82,174.1 million lei and increased by 6.4 percent compared to the previous year. Note that in 2013 the economic growth model of Moldova underwent significant changes. The primary factors that favored GDP growth in 2013 are the existence of increased external demand for domestic products, and increase household disposable income for the period. However, economic growth has been supported by positive developments in all sectors of the economy. The exports to the EU have produced some structural changes: on one hand the share of machinery and transport equipment and raw materials inedible, and on the other hand decreased share of manufactured articles, beverages and tobacco. These changes have led to a diversification of products exported to the EU. The results have shown a various research methodology as: deductive approach, inductive approach, comparative method, qualitative research to analyze the various concepts, notions and theories, quantitative analysis, document analysis and content analysis. The basic methods of research are analysis and synthesis, economic comparisons and statistical method. The conclusions and elaboration of recommendations regarding the implementation of international practices in the health trade's financing mechanism in the Republic of Moldova.*

**Key words:** export, economic growth, import, prices, Republic of Moldova

### **INTRODUCTION**

Exports and imports decreased in ten months by about one percent and three percent compared to the same period last year. According to the National Bureau of Statistics, from January to October, the country exported goods worth one billion 950 million dollars. Although the amount is 0.9 percent less than in the same period last year, sales on the Community market increased by 12.7 percent, the European Union still remains the main trading partner of Moldova, for which They've turned more than half of exports. The main European partner is Romania where they were sold goods worth over 350 million dollars. [2]

This is followed by Italy and Germany, where exports increased by 40 and 30 percent. Imports during this period were over four billion dollars. In ten months of imports of goods were 4.347 million dollars - 2.3 percent less than the same period last year. [2]

### **MATERIALS AND METHODS**

At the basis of this scientific paper served the information from the Statistics National Bureau of Republic of Moldova, Ministry of Economy of Moldavian Republic, different groups of national and international experts and also our own researches in this domain, were applied the following methods: selective, comparison and tabular methods.

### **RESULTS AND DISCUSSIONS**

The exports to the EU have produced some structural changes: on the one hand the share of machinery and transport equipment and inedible raw materials, and on the other hand decreased share of manufactured articles, beverages and tobacco. In roughly, these changes have led to a diversification of products exported to the EU. [1]

Exports of Moldova in the European Union were reflected in Table 1.

Table 1. Structure of the Moldovan exports to the European Union%

	2006	2007	2008	2009	2010	2011	2012
Food and live animals	17.4	15.6	11.1	16.9	16.8	15.9	17.2
Beverages and tobacco	7.5	3.3	3.5	3.8	3.2	2.7	2.8
Raw materials inedible, except fuels	6.7	9.9	8.9	7.9	9.2	14.4	8.1
Mineral fuels, lubricants and derivative	0.4	0.6	0.3	0.7	1.0	1.5	1.5
Oils, fats and waxes of animal or vegetable origin	4.1	4.7	4.2	3.5	4.7	6.7	8.5
Chemicals and derivatives nes	1.2	1.1	1.1	1.5	1.4	1.0	0.8
Manufactured goods classified mainly by raw material	13.5	13.4	12.8	7.3	6.1	5.2	4.2
Machinery and transport equipment	4.1	5.9	15.1	18.0	17.5	16.9	20.6
Miscellaneous manufactured articles	45.1	45.5	43.0	40.4	40.1	35.7	36.3

Source: prepared by the author based on National Bureau of Statistics

The share of exports to EU agro-food products is much smaller than the total export of the Republic of Moldova (in 2012 had a share of over 26% in total exports, compared to 17.2% in exports to the EU). This is due to incompatibility given category of products to existing technical standards in the EU. Moldova has begun the process of adjusting to EU standards of technical regulation; however, this process is very costly in terms of scarce national resources and flows slowly. As a general effect, granting autonomous trade preferences significantly improved access to the Community market of agricultural products, i.e. products from Moldova are admitted to import into the Community without quantitative restrictions or measures having equivalent effect and with exemption from customs duties and charges having equivalent effect except some, for which concessions are given in the form of

duty free tariff quotas within tariff reductions. If imports have not found essential structural changes. Imports from the EU are dominated by industrial products: chemicals, manufactured goods, machinery and transport equipment. However, imports of products are relatively diversified and structure of imports from EU countries in Moldova was reflected in Table 2.

Table 2. Structure of imports of Moldova in the European Union%

	2006	2007	2008	2009	2010	2011	2012
Food and live animals	5.5	5.2	5.5	8.0	8.8	6.7	8.0
Beverages and tobacco	1.7	1.6	1.7	1.8	2.1	1.5	1.9
Raw materials inedible, except fuels	1.9	1.8	1.6	1.7	1.8	2.0	1.9
Mineral fuels, lubricants and derivative	15.8	14.1	16.4	15.0	15.8	16.1	17.0
Oils, fats and waxes of animal or vegetable origin	0.4	0.3	0.3	0.1	0.2	0.2	0.2
Chemicals and derivatives nes	15.6	14.7	14.0	19.4	17.4	16.8	17.4
Manufactured goods classified mainly by raw material	24.7	24.0	20.5	19.7	20.4	20.2	18.9
Machinery and transport equipment	23.1	27.8	29.3	23.6	24.2	27.8	26.2
Miscellaneous manufactured articles	11.3	10.5	10.7	10.7	9.3	8.7	8.5

Source: prepared by the author based on National Bureau of Statistics

Tabular and handwriting analysis above allows us to deduce and to confirm that the economic relations with the European Union are very good and will continue to remain the main economic partner of the Republic of Moldova. However, there are factors that could diminish the intensity of economic relations and which, on the one hand, aim at modest economic developments in member countries of the European Union, and on the other hand, I particularly slow promotion of reforms in Moldova. The national economy is heavily dependent on the dynamics of the EU economy. Adverse economic developments in

the European Union, especially in Romania, Italy, Germany and Portugal may have adverse effects on flow-oriented Moldova: remittances, payments for the import of Moldovan and foreign investment. On the other hand, the intensification of structural reforms in Moldova would add quality economic relations with the European Union: -achieving the relevant enforcement measures necessary to align with European standards of quality, aimed: infrastructure, institutions aid, which in essence will stimulate export to the EU; -improving the business environment that will cause increasing interest in new investment projects in Moldova national and the EU economic agents of recipients.

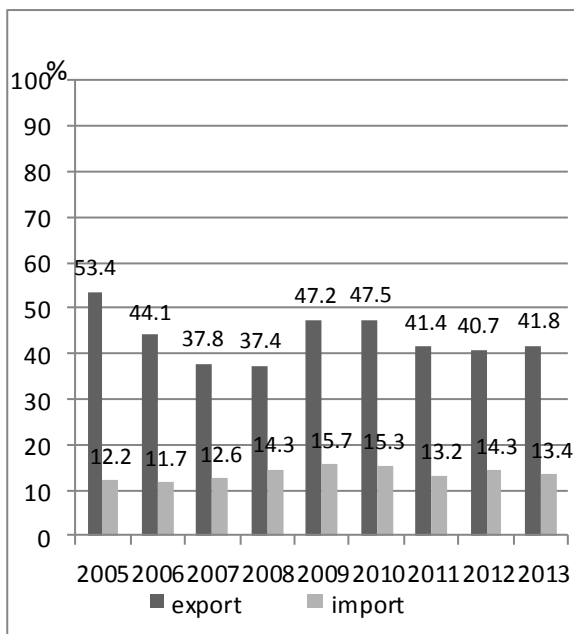

Fig. 1. Exports and imports of Moldova during 2005-2013 years

Source: Processed by author based on Statistical Yearbook NBS data for the respective years

To this end, we specify that such customs duties, excise and customs procedures is calculated from the customs value of imported goods in the same way as right and proper to calculate and VAT. Mechanism of the customs tax should be simplified to the maximum so the correct calculation of taxes and reducing tax rates, as well as the exclusion of all fiscal barriers that could reduce the final price of the goods.

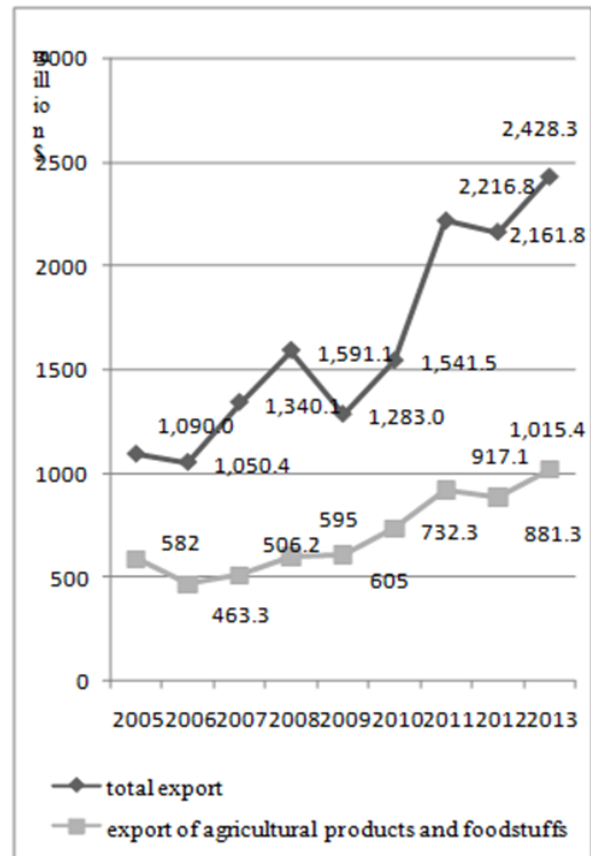

Fig. 2. Share of agricultural and food products in total exports and imports of the Republic, during 2005-2013 years

Source: Processed by author based on Statistical Yearbook NBS data for the respective years

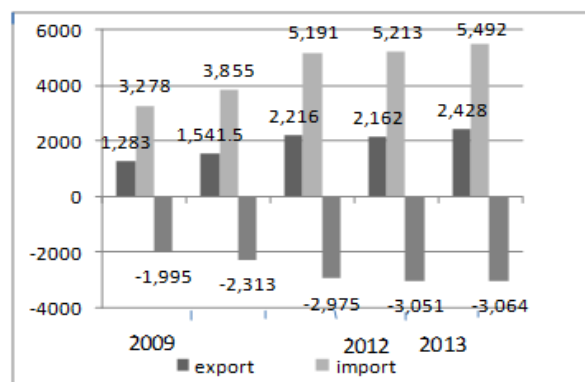

Fig. 3. Evolution of foreign trade of the Republic, 2009-2013 years

Source: Processed by author based on data Statistical Yearbook, NBS, and the corresponding years.

In the context of the above information, it becomes essential to reduce taxes paid in customs, their partial transposition direct taxes due. Reducing tax rate of indirect taxes would stimulate economic activity of domestic enterprises, creating opportunity to accumulate financial resources necessary

investment process, which, in turn, will lead to increasing wealth and increasing revenue. [3]

## CONCLUSIONS

Generalizing ideas, we conclude that the EU border near Moldova, acquiring membership of the World Trade Organization and the World Customs Organization and the tendency to implement the latest European standards imposed and still requires the current government to take important actions on improving the taxation of foreign economic activity, facilitating international trade, fiscal institutions and efficient tax administration, liquidation corruption and illegal introduction of goods and means of transport in the country.

A leading role in stabilizing economic processes lies optimize tax burden. Developing an efficient tax system remains one of the key issues to achieve change the result in the national economy. Connection and its efficiency are dictated by interests of the taxpayer, as well as those of the state. Often plays a decisive role not as part of each tax burden, as the full tax burden. Often, a tax may modify the calculation basis of another tax, which, in order of tax law, is charged under it and everything else will manifest this in the case of application / calculation of all taxes in the tax system.

It is necessary for businesses to be taxed after obtaining profit, but not before (customs). In order to continue improving the tax system and economic development of the country and to improve the functioning of the tax system in Moldova is very important to have the tax rate on income earned in particular for legal entities. [4]

We found a deep economic crisis in the state, through its fiscal policy and through government institutions, must opt for a very well thought out in order to protect domestic producers to boost exports. Cancellation of formal and informal barriers to international trade internal (control of export prices, the imposition modes of transport, payment of state taxes that have no effect on quality etc.). If it is impossible to reduce the customs tax should, at least, to abstain from introducing

protectionist tariffs and focus on eliminating competition between companies on the market dishonest controlling imports of goods and oriented to domestic producers. In this context, falls and facilitating access operators, in particular farmers to foreign markets by ensuring universal access to information on economic opportunities and market conditions. Along with the introduction and use of European customs standards, and local clearance, customs broker and improving the risk management system, the collection of duties for import / export, taxes and other payments through "single window", requires companies involved in international trade, a new way of life, equivalent to that of companies in the European countries. This phenomenon will generate new foreign economic relations with countries of the world, in particular the countries of the European Community. Accordingly, the transition from the autonomous trade preferences to a Deep Free Trade Agreement becomes a reality.

-Taxation of international trade can have both a positive impact, as well as negative. In this respect, the taxes at a balanced and optimal may have favorable repercussions on international trade and the economy as a whole, namely the accumulation of income in the state budget; protecting national economy aggressive foreign competition; restricting or encouraging trade in certain products to achieve a balance in the balance of trade and balance of payments (control the import and export of goods); geographical orientation of international trade flows.

It is necessary for businesses to be taxed after obtaining profit, but not before (customs). In order to continue improving the tax system and economic development of the country and to improve the functioning of the tax system in Moldova is very important to have the tax rate on income earned in particular for legal entities.

## REFERENCES

- [1]Diaconu, I, Moldoveanu, L., Ivan, M., 2007, Costuri, prețuri și tarife în economia modernă, Editura Tradiție, București, 101-107
- [2]National Strategy for Agricultural and Rural

Development of Republic of Moldova for the years  
2014-2020, 25-27

[3]Popa, D., Timofti, E., 2009, The efficiency of the  
economic mechanism in agriculture. Monograph.  
Chisinau Complex IEFS Publishing, 128-130

[4]Platiș Magdalena, 2002, Prețul și formarea lui.  
București, 15-17



## RESEARCH ON LABOUR PRODUCTIVITY IN ROMANIA'S AGRICULTURE

Agatha POPESCU

University of Agricultural Sciences and Veterinary Medicine, Bucharest, 59 Marasti, District 1, Zip code 011464, Bucharest, Romania, Phone:+40213182564, Fax: +40213182888, Email: agatha\_popescu@yahoo.com

*Corresponding author:* agatha\_popescu@yahoo.com

### Abstract

*The aim of the paper was to analyze Romania's labour productivity in agriculture, forestry and fishery based on the empirical data collected from the National Institute of Statistics for the period 2007-2012. A number of five methods of labour productivity calculation and the chain substitution method to analyze the influence of various factors were used, and finally the trends and solutions to increase labour productivity were identified. For all the productivity indicators there were calculated the statistical parameters: average, standard deviation, variance, standard error and variation coefficient. In the period 2007-2012, the average labour productivity in Romania's agriculture, forestry and fishery accounted for 7.7 persons per one person employed in this field of activity, Lei 23,482.83 agricultural production value per employed person in agriculture, Lei 11,456 gross value added per employed person in agriculture, Lei 11,198 per employed person and Lei 6.42 per hour worked in agriculture as found by NIS. The variation of these indicators was 16 % across the whole analyzed period. Labour productivity in Romania's agriculture is lower than in other sectors of the economy and mainly regarding the EU average and the top productivity in the Netherlands, Denmark, France, United Kingdom and Germany. In the period 2007-2012, Romania registered Euro 4,329/AWU representing 28.92 % of Euro 14,967/AWU average labour productivity in the EU-27. To increase labour productivity, it is needed to assure a modern technical endowment, the knowledge transfer to farmers, the increase of their training level and managerial skills, the intensification of the extension system services, the stimulation of young farmers and women to develop business in agriculture and traditional activities and services, the assurance of funding for investments and modernization, the creation of jobs and new income sources for the agricultural employees and rural population. Only in this way, profitability and competitiveness could be grown in agriculture.*

**Key words:** agriculture, characteristics, labour productivity, Romania, trends

### INTRODUCTION

Labour productivity reflects the efficiency in the economy and its fields of activity. In the EU, about 93 % of surface is represented by rural areas where about 20 % of its population is living.

Despite that just 4.7 % people is working in agriculture, in the EU, labour productivity has deeply increased in the last 20 years due to the increased use of productive factors from other economic sectors, despite of the disparities regarding land/labour ratio, fixed capital per farm, the exodus of people to cities, and the institutional framework involved in agriculture as mentioned by Martin-Retortillo Miguel (2012). [6]

The gap regarding the productivity differences among the CEECs was determined by a

variety of factors such as: reform choices and their implementation, and mainly land reform, price liberalization and the subsequent decline of trade, the decrease in output prices, the increase in input prices, reduced agricultural subsidies in agriculture, farm privatization, investments made by processors to support the supply chain, and quality of agricultural products.

The Czech Republic, Slovakia and Estonia implemented radical reforms, which consolidated land in large farming enterprises, stimulated outflow of labour, substantial gains in labour productivity, investments in vertically integrated supply chains, farmers' access to technology, inputs and output markets. Romania, Bulgaria, Lithuania and Poland with a diverse initial farm structure (Poland small family farms, and Lithuania,

Romania and Bulgaria (large agricultural holdings) followed a specific pattern of productivity, determined by land restitution to the former owners, the split of land into small plots, the lack of capital, led to small yields and limited gains in output and productivity as presented by Swinnen et al.(2009). [12]

Agriculture is an important sector in Romania's economy, a reason to analyze the dynamics of productivity and identify the factors which could contribute to its development.

Productivity reflects the qualitative relationship between production and the involved production factors, being usually defined as "a relation between the output resulting from the production process and the utilized factors" as affirmed Boghean et al.(2013). [1]

Productivity is determined by production level and the number of employed people, but also by fixed assets existing in the economy and investments in technical endowment which could assure a higher production performance per hour worked or employed person, a higher quality of the products, and an increased efficiency and competitiveness of the economy in general, at macroeconomic level, and at microeconomic level as well.

Work in agriculture has some specific peculiarities compared to other fields of activity, among the most important being: the seasonal agricultural works, the family members involved in the farm activities, the high share of the older population and women, the large variety regarding the applied technologies, the climate influence on production performance, etc, all these aspects leading to difficulties to estimate correctly employment and labour productivity in agriculture, as mentioned by Burja (2014). [2]

For this reason, the EU has established a conventional measure of labour productivity, AWU, meaning annual work unit, which is defined as: "the work performed by one person who is occupied on an agricultural holding on a full-time basis, meaning the minimum hours required by the relevant national provisions governing contracts of employment. If the national provisions do not indicate the number of hours, then 1 800

hours are taken to be the minimum annual working hours: equivalent to 225 working days of eight hours each. As the volume of agricultural labour is calculated on the basis of fulltime equivalent jobs" as mentioned in the EU, European methodology annexed to Regulation (EC) No 138/2004 of the European Parliament and of the Council of 5 December 2003 (with further additions) on the economic accounts for agriculture in the Community and the EU Report 2010, ANNEX A - Glossary of Terms & Definitions. [4, 5]

Romania has 238,391 km<sup>2</sup> surface, being the 12th country in Europe as size and representing 6 % of the EU surface. Of Romania's surface, about 55.8 %, that is 13.3 million ha are agricultural land, and of which 8.3 million ha are utilized arable land. In agriculture, forestry and fishery, the employment rate is 29.6%, very high compared to 4.7% in the EU. The population working in agriculture is aging, about 15% being over 65 years old, and the training level is very low.

The productivity in agriculture is lower than in other economic sectors, compared to the average in the national economy and the EU average as specified in the Document entitled "Socio-economic analysis in the prospect of the Rural Development 2014-2020, issued by Ministry of Agriculture and Rural Development (2013) [11]

Just 7.4 % of the Romanian farmers have a corresponding training in agriculture, compared to 20 % in the EU according to the Study of the National Commission for Forecast on "Agricultural Holdings Consolidation"(2012) [12]

Rural and agricultural population aging, low training level, the lack of financial resources and corresponding endowment, the migration to cities, the low annual income per farmer (just Euro 2,000) much below the EU average are the major features of Romania's agricultural labour with a deep impact on the productivity level as affirmed by Popescu Agatha, (2013 a). [7] The disparities between the EU developed agricultural countries and Romania could be diminished by training, high technologies, infusion of fixed capital



and investments, implementation of associative forms in agriculture as mentioned by Popescu Agatha (2013 b). [8]

In this context, the paper aimed to analyze labour productivity in Romania's agriculture based on the empirical data provided by the National Institute of Statistics for the period 2007-2012 in order to identify the main trends, the influencing factors and the ways how productivity could be developed in this important sector of the economy.

## MATERIALS AND METHODS

For setting up this paper, the empirical data were collected from Romania's Yearbooks provided by the National Institute of Statistics for the reference period 2007-2012.

Labour productivity (W) was calculated using the following three formulas:

$$W1 = P/EMa, \quad (1)$$

where W1= *labour productivity in terms of the number of persons per employed person in agriculture, forestry and fishery*, P=Romania's population, and EMa = employed persons in agriculture, forestry and fishery.

$$W2 = APV/EMa, \quad (2)$$

where W2= *labour productivity in terms of agricultural production value per employed person in agriculture, forestry and fishery*, APV = agricultural production value, and EMa = employed persons in agriculture, forestry and fishery.

$$W3 = GVAa/EMa, \quad (3)$$

where W3= *labour productivity in terms of gross value added in agriculture, forestry and fishery*, GVAa= gross value added in agriculture, forestry and fishery, and EMa = employed persons in agriculture, forestry and fishery.

*The comparison method and fixed basis index*,  $I_{FB} = (X_n/X_0)*100$ , where  $n = 1, 2, \dots, i$ , and 2007=100, were used to analyze the values of the indicators in 2012 compared to the reference term recorded in the year 2007.

Also, the statistical parameters: average, standard deviation and variation coefficients were calculated, according to the formulas:

*Average of the variable*,  $\bar{X}$ , using the well known formula:

$$\bar{X} = \frac{X_1 + X_2 + \dots + X_n}{n} \quad (4)$$

*Standard Deviation, S*, based on the formula:

$$S = \left( \frac{\sum_{i=1}^n (X_i - \bar{X})^2}{n-1} \right) \quad (5)$$

*Variation Coefficient, V%*, using the formula:

$$V\% = \frac{S}{\bar{X}} \times 100 \quad (6)$$

*The chain substitution analysis of the influence factors* was used in order to identify the influence of GVA on the change of labour productivity, as follows:

*The change of labour productivity*,  $\Delta W = \frac{GVA_1}{EM_1} - \frac{GVA_0}{EM_0}$

*The influence of GVA,  $\Delta W(GVA)$* , on the change of labour productivity,  $\Delta W$ :

$$\Delta W(GVA) = \frac{GVA_1}{EM_0} - \frac{GVA_0}{EM_0}$$

$$\Delta W(GVA)\% = (\Delta W(GVA) / \Delta W) * 100$$

*The influence of  $EM_a$ ,  $\Delta W(EM_a)$* , on the change of labour productivity,  $\Delta W$ :

$$\Delta W(EM_a) = \frac{GVA_1}{EM_1} - \frac{GVA_1}{EM_0}$$

$$\Delta W(EM_a)\% = (\Delta W(EM_a) / \Delta W) * 100$$

To check if the calculations were correctly done, the sum of the influence of GVA and  $EM_a$  should be equal to  $\Delta W$ , according to the formula:

$$\Delta W = \Delta W(GVA) + \Delta W(EM_a)$$

In a similar way, it was used the same method to determine the influence of agricultural production value, APV, on the change of labour productivity in 2012 versus 2007, replacing GVA with APV in the formulas presented above.

The obtained results were tabled and graphically illustrated and then interpreted.

The specific indicators taken into consideration in this research, there were: total population of Romania, rural population, employed persons in agriculture, forestry and fishery, agriculture production value, gross

value added created in agriculture, forestry and fishery, and also the labour productivity in terms of Lei/employed person and per hour worked as provided by the National Institute of Statistics for the reference period 2007-2012.

For each indicator taken into consideration, there were calculated the statistical parameters: average, standard deviation and the coefficient of variation.

## RESULTS AND DISCUSSIONS

**Labour productivity in terms of number of persons per one person employed in agriculture, forestry and fishery** varied between 7.28 persons, the minimum value registered in the year 2010 and 7.71 persons, the maximum level recorded in the year 2011. The general trend was a descending one from 7.57 persons in 2007 to 7.49 persons in 2012. (Table 1).

Table 1. Labor productivity in terms of Number of persons per employed people in agriculture, forestry and fishery, Romania, 2007-2012

	MU	2007	2008	2009	2010	2011	2012	2012/2007 %
Labor productivity	No. of persons/ One person employed in agriculture, forestry and fishery	7.57	7.63	7.57	7.28	7.71	7.49	98.94

Source: Own calculation based on NIS, 2013, Romania's Statistical Yearbook, 2008-2013 [10]

In the last year of the analysis, the figure was by 42 % smaller compared to the average of 12.9 persons found by Tofan (2005) in Romania, and much smaller compared to the one recorded in other EU countries: 49.3 persons in the EU-15, 165.6 persons in Belgium-Luxembourg, 104 persons in the Netherlands, 76.3 persons in France, 74.2 persons in Denmark, 60.6 persons in Germany, 57.3 persons in United Kingdom as mentioned by Tofan (2005). [14]

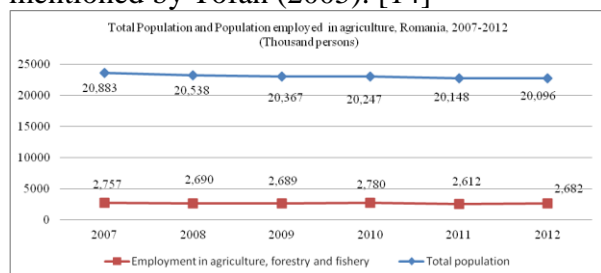

Fig.1. Dynamics of the total population and population employed in agriculture, forestry and fishery in Romania, 2007-2012

Source: NIS, 2013, Romania's Statistical Yearbook. [10] Own design.

The reduction of this indicator is explained by the decline by 3.77 % of the total population in Romania and also by the decline by 2.73 % of the employed persons in agriculture, forestry and fishery in the analyzed period. It reflects that less people could be fed by people working as employees in the agricultural sector. ( Fig.1.)

**Labour productivity in terms of agricultural production value per employed person in agriculture, forestry and fishery** increased by 38.48 % from Lei 17,301/employed person in 2007 to Lei 23,959 per employed person in 2012. This was due to the increase of the agricultural production value by 34.71 % in the analyzed period, which had a positive influence and also due to the decline of the number of persons employed in agriculture, forestry and fishery by 2.73 %, which had a positive effect as well ( Fig.2., Table 2).

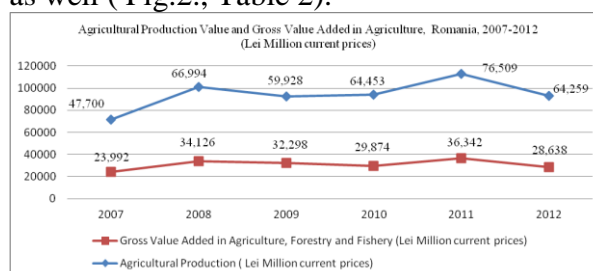

Fig.2. Agricultural Production Value and Gross Value Added in agriculture, forestry and fishery, Romania, 2007-2012 ( Lei Million current prices)

Source: NIS, 2013, Romania's Statistical Yearbook. [10] Own design.

In Euro, this means that in 2012, labour productivity accounted for Euro 5,324, being by 3.56% smaller than Euro 5,520/person employed in agriculture determined by Tofan (2005) in Romania and the figure is also much lower compared to Euro 36,804, the EU-15 average, Euro 89,836 in Belgium, Euro

78,668 in the Netherlands, Euro 71,128 in France, Euro 45,430 in United Kingdom and Euro 42,337 in Germany as affirmed Tofan (2005).[14]

Table 2.Labour productivity in terms of Agricultural Production Value per employed people in agriculture, forestry and fishery, Romania, 2007-2012

	MU	2007	2008	2009	2010	2011	2012	2012/2007 %
Labour productivity	Lei Employed person in agriculture, forestry and fishery	17,301	24,905	22,256	23,185	29,291	23,959	138.48

Source: Own calculation based on INSSE Data base, 2008-2013. [10]

To analyze the influence of the two factors of influence, APV and  $EM_a$ , on the change of labour productivity,  $\Delta W$ , in the year 2012 compared to the year 2007, the following calculations were done:

*The change of labour productivity,*

$$\Delta W = \frac{APV_{2012}}{EM_{2012}} - \frac{APV_{2007}}{EM_{2007}} = \frac{64,259}{2,682} - \frac{47,700}{2,757} =$$

Lei 6,657.94/ employed person in agricultural sector.

*The influence of APV,  $\Delta W(APV)$ , on the change of labour productivity,  $\Delta W$ :*

$$\Delta W(APV) = \frac{APV_{2012}}{EM_{2007}} - \frac{APV_{2007}}{EM_{2007}} =$$

$$\frac{64,259}{2,757} - \frac{47,700}{2,757} = \text{Lei } 6,006.17/\text{employed person.}$$

$$\Delta W(APV)\% = \left( \frac{\Delta W(APV)}{\Delta W} \right) * 100 = \left( \frac{6,006.17}{6,657.94} \right) * 100 = 90.21 \%$$

*The influence of  $EM_a$ ,  $\Delta W(EM_a)$ , on the change of labour productivity,  $\Delta W$ :*

$$\Delta W(EM_a) = \frac{APV_{2012}}{EM_{2012}} - \frac{APV_{2012}}{EM_{2007}} =$$

$$\frac{64,259}{2,682} - \frac{64,259}{2,757} = \text{Lei } 651.77/\text{employed person.}$$

$$\Delta W(EM_a)\% = \left( \frac{\Delta W(EM_a)}{\Delta W} \right) * 100 = \left( \frac{651.77}{6,657.94} \right) * 100 = 9.79 \%$$

The calculations were correctly done, because the sum of the influence of APV and  $EM_a$

were equal to  $\Delta W$ , as follows:

$$\Delta W = \Delta W(APV) + \Delta W(EM_a) = 6,657.94 = 6,006.17 + 651.77.$$

Therefore, the change of labour productivity Lei 6,657.94/person employed in agriculture in the year 2012 compared to 2007 was determined 90.21 % by agricultural production value, APV, and 9.79 % by employment in agriculture,  $EM_a$ .

The influence of APV and  $EM_a$  on the change of labour productivity is presented in Table 4.

**Labour productivity in terms of Gross Value Added created in agriculture, forestry and fishery per employed person in agriculture, forestry and fishery** increased by 23.74 % from Lei 8,702 in the year 2007 to Lei 10,678 in the year 2012.

This growth was positively influenced by the increase of Gross Value Added in agriculture, forestry and fishery by 19.36 % and also by the decline by 2.73 % of the employed persons in the agricultural sector ( Table 3, Fig.2.).

Transformed into Euro, at an exchange rate (Euro 1 = Lei 4.50), this means that in 2012, in Romania's agriculture, labour productivity accounted for Euro 2,373 gross value added per employed person. This level is by 20 % lower than the average calculated by Tofan (2005) who found Euro 2,949 GVA/employed person in the agricultural sector.

This figure was also lower compared to Euro 19,314 the EU-15 average and the level recorded by other EU countries: Euro 35,437 in the Netherlands, Euro 35,511 in France, Euro 34,091 in Belgium, Euro 32,685 in Luxembourg, Euro 31,902 in Denmark.

Table 3. Labour productivity in terms of Gross Value Added per employed people in agriculture, forestry and fishery, Romania, 2007-2012

MU		2007	2008	2009	2010	2011	2012	2012/2007 %
Labour productivity	Lei Employed person in agriculture, forestry and fishery	8,702	12,686	12,011	10,746	13,913	10,678	123.74

Source: Own calculation based on INSSE Data base, 2008-2013. [10]

To analyze the influence of the two factors of influence, GVA and EM<sub>a</sub>, on the change of labour productivity, ΔW, in the year 2012 compared to the year 2007, the following calculations were done:

The change of labour productivity, ΔW:

$$\frac{GVA_1}{EM_1} - \frac{GVA_0}{EM_0} = \frac{28,638}{2,682} - \frac{23,992}{2,757} = \text{Lei } 1,975/\text{employed person in agricultural sector.}$$

The influence of GVA, ΔW(GVA), on the change of labour productivity, ΔW:

$$\Delta W(GVA) = \frac{GVA_{2012}}{EM_{2007}} - \frac{GVA_{2007}}{EM_{2007}} = \frac{28,638}{2,757} - \frac{23,992}{2,757} = \text{Lei } 1,685/\text{employed person.}$$

$$\Delta W(GVA)\% = \left( \frac{\Delta W(GVA)}{\Delta W} \right) * 100 = \left( \frac{1,685}{1,975} \right) * 100 = 85.31 \%$$

The influence of EM<sub>a</sub>, ΔW(EM<sub>a</sub>), on the change of labour productivity, ΔW:

$$\Delta W(EM_a) = \frac{GVA_{2012}}{EM_{2012}} - \frac{GVA_{2007}}{EM_{2007}} =$$

$$\frac{28,638}{2,682} - \frac{28,638}{2,757} = \text{Lei } 290/\text{employed person.}$$

$$\Delta W(EM_a)\% = \left( \frac{\Delta W(EM_a)}{\Delta W} \right) * 100 = \left( \frac{290}{1,975} \right) * 100 = 15 \%$$

The calculations were correctly done, because the sum of the influence of GVA and EM<sub>a</sub> were equal to ΔW, as follows:

$$\Delta W = \Delta W(GVA) + \Delta W(EM_a) = 1,975 = 1,685 + 290.$$

Therefore, the change of Lei 1,975/person employed in agriculture in the year 2012 compared to 2007 was determined 85.31 % by gross value added obtained in agriculture, GVA, and 15 % by employment in agriculture, EM<sub>a</sub>.

A similar results was found by Boghean et al.(2013) who analyzed the change of labour productivity in the year 2011 against 2010 and found that GVA had a higher influence, 62.39 % while EM<sub>a</sub> had a lower influence of 37.61 %. [1]

The influence of GVA and EM<sub>a</sub> on the change of labour productivity is presented in Table 4.

Table 4. The influence of APV, GVA and EM<sub>a</sub> on the change of labour productivity in agriculture, forestry and fishery in 2012 versus 2007

Change of Labour productivity due to APV and EM <sub>a</sub>					Change of Labour productivity due to GVA and EM <sub>a</sub>						
ΔW		ΔW(GVA)		ΔW(EM <sub>a</sub> )		ΔW		ΔW(GVA)		ΔW(EM <sub>a</sub> )	
Lei	Lei	%	Lei	%	Lei	Lei	%	Lei	Lei	%	
1,975	1,675	85.31	290	15	6,657.94	6,006.17	90.21	651.77	9.79		

Source: Own calculations.

The labour productivity is the combined result of various factors, but mainly of the labour market trends and market failure the change of production performance and the variation of gross value added produced in agriculture, forestry and fishery.

For instance, in 1990, 29 % employed people

in agriculture created 22 % of the GVA in Romania's economy, in 2000, 41.7 % employed persons in agriculture produced 12.5 % GVA in the economy, and in 2012 about 29 % population employed in agriculture contributed by just 6.5 % to the national GVA as mentioned Ciutacu

et.al.(2014). [3]

**Labour productivity in agriculture, forestry and fishery in Lei per employed person in the agricultural sector as determined by the National Institute of Statistics** ranged between Lei 8,448.7/person in 2007 and Lei 13,343.7/person in 2011, when the level was by 57.93 % higher than in the 1st year of the analyzed period.

The evolution of labour productivity in

agriculture was more dynamic compared to the labour productivity in Romania's economy, whose growth was 36.52 % in the same period. As a result, the weight of the labour productivity achieved in the agricultural sector in the labour productivity recorded in the national economy increased from 21.47 % in 2007 to 24.84 % in the year 2011.(Table 5)

Table 5. Labour productivity in the national economy and in agriculture, forestry and fishery, Romania, 2007-2011 (Lei/employed person)

	2007	2008	2009	2010	2011	2011/2007 %
Labour productivity in the national economy	39,334.1	48,958	49,120.9	50,938.4	53,702.1	136.52
Labour productivity in the agricultural sector	8,448.7	12,198.2	11,684.3	10,315	13,343.7	157.93
Share of agriculture (%)	21.47	24.91	23.78	20.24	24.84	-

Source: NIS, 2013, Romania's Statistical Yearbook. [10]Own calculation.

Compared to the national average labour productivity, which accounted for Lei 53,702.1/employed person in agriculture in 2011, the productivity level was 4.02 times lower, reflecting a better situation than 4.65 times less in the year 2007.

The low productivity level in the agricultural sector was determined by a series of factors such as: the low quality biological material used in the vegetal and animal sector, the low technical endowment, the reduced number of farmers with professional qualification, the high proportion of land per agricultural

worker, the numerous holdings (3.8 million) with an average size of 3.4 ha, the highest number of people dealing with agriculture, the low production performance, all these aspects reflect that Romania's agriculture could not meet the performance achieved in the developed countries of the EU as mentioned Trasca Daniela (2015). [15]

**Labour productivity in agriculture, forestry and fishery in Lei per hour worked in the agricultural sector as determined by the National Institute of Statistics** increased by 57.14 % from Lei 4.9/hour in 2007 to Lei 7.7./hour in 2011. (Table 6).

Table 6. Labour productivity in the national economy and in agriculture, forestry and fishery, Romania, 2007-2011 (Lei/hour worked)

	2007	2008	2009	2010	2011	2011/2007 %
Labour productivity in the national economy	20.9	26.1	26.3	27.4	28.4	135.88
Labour productivity in the agricultural sector	4.9	7.0	6.6	5.9	7.7	157.14
Share of agriculture (%)	23.44	26.81	25.09	21.53	27.11	-

Source: NIS, 2013, Romania's Statistical Yearbook. [10]Own calculation.

However, the labour productivity in the agricultural sector is very small compared to the average in the national economy. In 2011, it was 3.68 times lower than at the national level compared to 4.26 times lower in the year 2007.

The gap recorded a slight reduction, which is

a positive aspect.

**The statistical parameters of Labour productivity in agriculture, forestry and fishery** in the period 2007-2012, determined in 5 manners is presented in Table 7.

Table 7. Statistical parameters of Labour productivity in agriculture, forestry and fishery in the period 2007-2012 in Romania

Statistical parameter/ Labour productivity type	MU	Average	Standard deviation	Standard error	Sample variance	Variation coefficient(%)
W1	-	7.536	0.1642	0.0734	0.0269	2.17
W2	Lei/employed person	23,482.83	3,893.4041	1,589.4756	15,158,596.17	16.57
W3	Lei/employed person	11,456	1,819.4325	742.7802	3,310,334.80	15.88
W4	Lei/employed person	11,198	1,882.6979	841.9679	3,544,550.50	16.81
W5	Lei/Hour worked	6.42	1.0709	0.4789	1.147	16.68

Source: Own calculations.

W1=Labour productivity in terms of No. persons/ $EM_a$ ; W2= Labour productivity in terms of APV/ $EM_a$ ;

W3= Labour productivity in terms of GVA/ $EM_a$ ; W4= Labour productivity in terms of Lei/employed person in agriculture, as determined by INSSE, 2013; W5= Labour productivity in terms of Lei/Hour worked in agriculture, as determined by INSSE, 2013.

### Labour productivity in Romania compared to other EU countries in terms of GVA, at basic price in Euro/AWU.

Romania is situated on the penultimate position in the EU, being followed by Bulgaria, which is placed on the last position. Romania is still far away from the EU average productivity and of the top productivity registered by the Netherlands, Denmark, Belgium, France, United Kingdom and Germany as affirmed Popescu Marian (2011). [9]

The EU-27 average labour productivity for the period 2007-2012 was Euro 14,967/AWU. Romania registered Euro 4,329/AWU, representing 28.92 % of the EU average productivity in agriculture. Germany recorded Euro 20,259/AWU, that is an almost double productivity in agriculture compared to the EU average and 6.75 times more than Romania. Poland achieved Euro 4,054/AWU by 73 % less than the EU average and by 6.36 % less than Romania. Hungary achieved Euro 5,717/AWU, that is 38.19 % of the EU average and by 32.06 % more than Romania. Bulgaria recorded the lowest labour productivity in agriculture, accounting for Euro 3,826/AWU, being by 75 % lower than the EU average and by 11.62 % lower than the one recorded in Romania as presented by Burja (2014). [2]

A recent study proved that in Romania, farm

structure is a major problem with a negative impact on labour productivity. The farms over 100 ha UAA exceed the EU-27 averages with regard to the indicators assessing economic performance. The farmers owning less than 10 ha achieve lower performance in agriculture below the EU-27 average: by 93% less in standard output value, by 91%

less hectares of UAA and 90% less in LSU per holding. They produce by 85 % agricultural output, and manage fewer hectares per full-time equivalent worker (80%). The farms whose size varies between 10 and 100 ha represent just 2 % of the total number of holdings and utilize 12.3% of total UAA. This farm sized model is closer to the EU average performance: 63% of the SO value/holding, 63% more hectares of UAA and 8% less in LSU per holding. However, the economic output per full-time equivalent worker is lower than the EU-27 average, as is the number of hectares managed per AWU. But, this farm model should be supported to develop and improve farm structure in Romania and contribute to the increase of labour productivity, production and product quality, competitiveness and efficiency in this economic sector as affirmed Tudor Monica Mihaela (2014). [16]

**The main causes of the low labour productivity in Romania's agriculture are the following ones:**

- (i) The low technical endowment in agriculture and low investment in fixed assets;
- (ii) the high number of persons employed in agriculture or dealing with agricultural works to compensate the lack of modern machinery, equipments;
- (iii) the low production performance determined by the extensive technologies used and low inputs (fertilizers, herbicides, pesticides) and also the use of low potential biological material;
- (iv) the non corresponding farm structure, dominated by subsistence and semi-subsistence farms lacked of modern fixed and financial capital;
- (v) the low training level of the farmers, most of them practicing traditional agriculture; only 1 % agricultural holdings are market oriented commercial companies, managed by high qualified managers, able to carry out high productions and high quality agricultural products and assure the profitability and competitiveness of their agricultural holdings;
- (vi) the rural population aging and the high share of women working in agriculture, many of them having a low training level and weak managerial skills;
- (vii) a few number of farmers' organization forms (co-operatives or producers' associations) to enable them to use their fixed, financial and human capital in a more efficient manner, to assure inputs at a lower price and sell much better their agricultural products on various markets to get a higher price;
- (viii) the lack of attraction of agriculture for the young generation who prefer to migrate to cities looking for better paid jobs as long as work motivation in agriculture is weak, as income coming from full time agriculture is very small compared to other economic sectors or in the EU agriculture.
- (ix) the climate conditions and mainly the climate change which have a stronger and stronger influence on the agricultural production.

## CONCLUSIONS

Labour productivity in Romania's agriculture reflects a low work efficiency in this sector of

the economy where many efforts are done and many times the results do not meet the expectations.

Labour productivity in agriculture, forestry and fishery is lower than in industry, constructions, trade etc and also compared to the EU average and with the one recorded in almost all the EU-28 member states.

From this point of view, Romania comes on the penultimate position in the EU-28, being followed only by Bulgaria.

To increase labour productivity, it is necessary an important financial support for farmers to develop the endowment and modernized their farms, to apply the modern technologies, increase production and product quality and profitability.

Knowledge transfer should be assured by a deeper involvement of the agricultural consultancy system in farmers training, the delivery of good practices and farm models and the development of technical and managerial skills.

Young farmers should be stimulated, supported and encouraged to set up their business in agriculture and be aware that agriculture is a profitable sector in the economy.

Also, traditional industries and services should be developed in the rural areas for assuring jobs and increasing income and the living standard of the rural population and the economic viability of the rural households.

According to the Horizon 2014-2020 Programme launched by the EU to strengthen the agriculture and rural development by an important financial support allocated for knowledge transfer, modernization of the small and semi-subsistence farms, young and women farmers training, increase of profitability and competitiveness, and assure the sustainable development of the rural areas.

## REFERENCES

- [1] Boghean Carmen, State Mihaela, 2013, Analysis of the factors affecting the average labour productivity variation in agriculture, forestry and fishing in Romania, the University of Suceava Annals of Economics and Public Administration, vol,13,2(18):35-42

[2]Burja Vasile, 2014, Some aspects of employment in Romania's agriculture on the European context, *Annales Universitatis Apulensis Series Oeconomica*, 16(1), 2014, 41-51

[3]Ciutacu C., Chivu, L., Andrei, J.V., 2014, Similarities and dissimilarities between the EU agricultural and rural development model and Romanian agriculture. Challenges and perspectives, *Land Use Policy*, Volume 44, March 2015, 169–176

[4]EU, European methodology annexed to Regulation (EC) No 138/2004 of the European Parliament and of the Council of 5 December 2003 (with further additions) on the economic accounts for agriculture in the Community

[5]EU Report 2010, ANNEX A - Glossary of Terms & Definitions, [http://ec.europa.eu/agriculture/agrista/rurdev2010/RD\\_Report\\_2010\\_Annexe-A.pdf](http://ec.europa.eu/agriculture/agrista/rurdev2010/RD_Report_2010_Annexe-A.pdf)

[6]Martin-Retortillo Miguel, Pinillia Vicente, 2012, Why did agricultural labour productivity not converge in Europe from 1950 to 2005?, *EHES Working Papers in Economic History*, No.25, Oct.2012

[7]Popescu Agatha, 2013a, Considerations on the Rural Population as a Resource of Labor Force in Romania, *Scientific Papers Series Management, Economic Engineering in Agriculture and Rural Development*, Vol.13(3):229-236

[8]Popescu Agatha, 2013b, Considerations on the main features of the agricultural population in the European Union, *Scientific Papers Series Management, Economic Engineering in Agriculture and Rural Development*, Vol.13(4):213-220

[9]Popescu Marin, 2009, Labour employment in Romania's agriculture and labour productivity increase. Gaps between Romania and European Union, *Agricultural Economics and Rural Development*, New Series, Year VI(2):181–197

[ftp://www.ipe.ro/RePEc/iag/iag\\_pdf/AERD0902\\_181-198.pdf](ftp://www.ipe.ro/RePEc/iag/iag_pdf/AERD0902_181-198.pdf);

[10] Romania's Statistical Yearbooks, 2008-2013. National Institute for Statistics, [ww.insse.ro](http://www.insse.ro)

[11]Socio-economic analysis in the prospect of the rural development 2014-2020, MARD, Authority of Management for NPRD, [http://www.madr.ro/docs/dezvoltare-rurala/Descrierea\\_generala\\_a\\_situatiei\\_economice\\_actuale\\_4\\_11\\_2013.pdf](http://www.madr.ro/docs/dezvoltare-rurala/Descrierea_generala_a_situatiei_economice_actuale_4_11_2013.pdf)

[12] Study of the National Commission of Forecast on "Agricultural Holdings Consolidation", 2012

[13]Swinnen Johan F.M., Van Herck Kristine, 2009, Vranken Liesbet, *Agricultural Productivity in Transition Economies*, Choices, 4th Quarter 2009, 24(4)

[14]Tofan, A.,2005, Labor Productivity in Agriculture, *Scientific Annals of Alexandru Ioan Cuza University*, Iasi, 441-447

[15]Trasca Daniela, 2015, Challenges of agricultural companies from the perspective of labour productivity and funding access, *Scientific Papers Series Management, Economic Engineering in Agriculture and Rural Development*, Vol.11(1):533-537

[16]Tudor Monica Mihaela, 2011, Performance of the

farm management in Romania after 20 years of transformations, *Scientific Papers Agricultural Management, Series I*, Vol.XVI(2):17-25



## RESEARCH ON ROMANIA'S EMPLOYMENT IN AGRICULTURE AND ITS POSITION IN THE EUROPEAN UNION

Agatha POPESCU, Reta CONDEI

University of Agricultural Sciences and Veterinary Medicine, Bucharest, 59 Marasti, District 1, Zip code 011464, Bucharest, Romania, Phone:+40213182564, Fax: +40213182888, Email: agatha\_popescu@yahoo.com, r\_condei@yahoo.com

*Corresponding author:* agatha\_popescu@yahoo.com

### Abstract

*The paper analyzed Romania's employment in agriculture, forestry and fishery in the period 2007-2012 using the empirical provided by the National Institute of Statistics and Eurostat and the specific methods for such a study: statistical parameters, fixed index method, and comparison method. In 2012, in Romania's agriculture were employed 2,682 thousand persons, representing 64.07 % of the employed rural population and 28.95 % of the employment in the economy, the highest level in the EU where the average accounted for 4.7 %. Of the employed persons in Romania's agriculture, 53.5 % were sole holders, 45 % family members and 1.5 % non family regular workers. Also, 53.1 % were men. Romania came on the last position in the EU-27 for the people employed full time in agriculture (0.9%) and on the penultimate position for 83 % employed persons in small holdings SO<Euro 4,000. Aging is another feature as of the total employed persons in agriculture, 38.8 % were between 15-30 years old, 47.2 % were between 40-64 years old and 13.9 % were of 65 and over. Romania's agriculture is dominated by family farms, the most people being part-time employed in farm work, agricultural works are achieved in small farms, the employed population is aging, the most of the young people is not attracted by agriculture looking for better paid jobs in the cities or abroad. To improve the situation, it is needed the diversification of the activities in the rural areas to create new jobs and increase income, to stimulate the young people and women to work in the rural areas by developing services and industry, preserving traditions, folklore, local gastronomy, handicrafts. The Horizon 2014-2020 Programme is destined to strengthen labour force and agriculture performance by offering funding for knowledge transfer, technical and managerial skills development for young, small farmers and women and for agri-business encouragement.*

**Key words:** agriculture, characteristics, employment, Romania, trends

### INTRODUCTION

Romania is an agricultural country where family small subsistence farms are predominant. Family members regularly use to provide labour in various moments of the year, giving a seasonal character of work in agriculture. Another major feature is the fact that many people dealing with agriculture is part-time employed in farms and have other jobs and income sources, as the income from agriculture is very small as mentioned by Dumitru et. al.(2004), [3], Popescu Agatha (2013a) [7] and Burja (2014). [1]

This situation is not so different with the one characterizing the EU agriculture as mentioned in "How many people work in agriculture in the European Union? An answer based on Eurostat data sources" (2013) issued by the European Commission

and by Popescu Agatha (2013b) [8]

Employment in agriculture is presented in different ways according to the purposes, information source, and used methodology. Sometimes the data could not be compared if they are collected from various information sources. Employment is expressed in terms of persons employed in agriculture in AWU (annual work unit) in the EU Farm Structure Survey. [4]

Migration of labour force in the developed EU countries is sometimes not included in the employment statistics as affirmed by Burja (2014) [1]

Employment varies between the EU countries and also in Romania according to macro and micro regions, depending on the conditions suitable for practicing agriculture, traditions, existence of vacant jobs, attractiveness and other factors as affirmed Condei et al.,

(2015). [2]

In Romania, labor force is overdimensioned compared to other EU countries, as in the rural areas are living about 45 % of the population and most of the people are dealing with agriculture. For this reason, employment in agriculture represent about 29 % in Romania in comparison with 4.7 % in the EU as mentioned in the MARD Study on "Socio-economic Analysis of the 2014-2020 Prospect of the Rural Development".[10]

Analyzing labor force in Romania, Tocco et al.(2014) affirmed that working in agriculture could be a decision determined by "tradition and cultural reasons, or because farmers enjoy the autonomy of self-employment rather than working in a company". Among the features characterizing the outflow and inflow in agriculture labour force are: population aging and retirement and young and higher educated people migration to cities or abroad as the main outflow channels, and unemployment and retirement of the people working in industry and services, as the main channels of inflow. [11]

In this context, the goal of the paper was to analyze the employment in agriculture, forestry and fishery in Romania's agriculture and identify the main trends, features and ways to be improved using the empirical data provided by various sources such as the National Institute of Statistics and the EU Commission Statistics on the topic for the period 2007-2012. Finally, it was aimed to establish Romania's position in the EU regarding employment in agriculture.

## MATERIALS AND METHODS

The paper is based on the empirical data collected from various information source such as: Romania's Yearbooks provided by the National Institute of Statistics for the reference period 2007-2012, the EU Eurostat Farm Structure Survey and Labour Force Survey. [4, 5, 9]

The fixed basis index,  $I_{FB} = (X_n/X_0)*100$ , where  $n=1,2,...,i$ , was used to determine the growth in the analyzed period 2007-2012, and also the Comparison Method was utilized to emphasize the differences between the main

indicators characterizing Romania's employment in agriculture and in other economic sectors and also with the EU-27 employment in agriculture.

The main indicators used to characterize Romania's employment in agriculture were the following ones: rural population and its share in the total population, active rural population and its share in total active population, rural employment and its share in the total employment, employment in agriculture and its share in the rural employment and total employment, employment structure in agriculture by professional status, age group and gender, position of Romania in the EI-27 for employment in agriculture (no. of persons and in AWU), employment structure (sole holders, family members, non-family regular workers), the share of employed men, average workers per holding, people full time employed in agriculture, persons working in holdings with  $SO < \text{Euro } 4,000$ .

Also, the statistical parameters: average, standard deviation and variation coefficients were calculated, according to the formulas:

*Average of the variable,  $\bar{X}$* , using the well known formula:

$$\bar{X} = \frac{X_1 + X_2 + \dots + X_n}{n} \quad (4)$$

*Standard Deviation, S*, based on the formula:

$$S = \sqrt{\frac{\sum_{i=1}^n (X_i - \bar{X})^2}{n-1}} \quad (5)$$

*Variation Coefficient,  $V_{\%}$* , using the formula:

$$V_{\%} = \frac{S}{\bar{X}} \times 100 \quad (6)$$

The results were displayed in tables.

## RESULTS AND DISCUSSIONS

**The rural population in Romania** accounted for 9,242 thousand persons in the year 2012, being by 1.97 % lower than in the year 2007. It followed the general slight decreasing trend as the total population in the

country. However, the total population declined by 3.77 % during the 2007-2012 period and as a result, the weight of the rural population in the total population increased from 45.14 % in 2007 to 45.99 % in 2012 (Table 1).

Table 1. The dynamics of the rural population and its share in Romania's total population, 2007-2012 (thousand persons)

Specification	2007	2008	2009	2010	2011	2012	2012/2007 %
Rural population	9,427	9,435	9,391	9,325	9,270	9,242	98.03
Total population	20,883	20,538	20,367	20,247	20,148	20,096	96.23
The share of the rural population in the total population (%)	45.14	45.93	46.10	46.05	46.00	45.99	-

Source: Romania's Statistical Yearbooks, 2008-2013, Chapter 2. [9]

**The active population** in the rural area also registered a slight decrease of 1.98 % from 4,500 thousand persons in 2007 to 4,411 thousand persons in 2012. The descending trend was similar to the general trend of the active population in Romania, but the decline

of the rural population was more evident so that, in 2012, the share of the active rural population in the total active population was 44.26 % a little lower compared to 45.02 % in 2007 (Table 2).

Table 2. The dynamics of the active rural population and its share in Romania's total active population, 2007-2012 (thousand persons)

Specification	2007	2008	2009	2010	2011	2012	2012/2007 %
Active Rural population	4,500	4,473	4,449	4,427	4,305	4,411	98.02
Total active population	9,994	9,944	9,924	9,965	9,968	9,964	99.70
The share of the active rural population in the total active population (%)	45.02	44.98	44.83	44.42	43.18	44.26	-

Source: Romania's Statistical Yearbooks, 2008-2013, Chapter 3. [9]

**The employed people in the rural area** followed a similar decreasing trend. In 2012, there were 4,186 employed persons in the rural space by 2.22 % less than in 2007.

As a consequence, in 2012, the share of employed persons in the rural area in the total employment at the national level registered a slight decrease from 45.77 % in 2007 to 45.19 % in 2012. (Table 3).

Table 3. The dynamics of employment in the rural areas and Romania's employment, 2007-2012 (thousand persons)

Specification	2007	2008	2009	2010	2011	2012	2012/2007 %
Employment in the rural areas	4,282	4,268	4,211	4,208	4,066	4,186	97.78
Total employment	9,353	9,369	9,243	9,240	9,138	9,263	99.04
The share of rural employment in the total employment (%)	45.77	45.55	45.55	45.54	44.50	45.19	-

Source: Romania's Statistical Yearbooks, 2008-2013, Chapter 3. [9]

**The employment in agriculture, forestry and fishery** also declined by 2.73 % from 2,757 thousand persons in 2007 to 2,682 thousand persons in 2012.

In 2012, agriculture, forestry and fishery absorbed 64.07 % of the rural employed people and 28.95 % of the people employed in the national economy. (Table 4).

As a consequence, in the analyzed period, the share of employment in agriculture, forestry and fishery decreased both in the total employment in the economy and in the rural employment.

Table 4. The dynamics of employment in agriculture, forestry and fishery in Romania, 2007-2012 (thousand persons)

Specification	2007	2008	2009	2010	2011	2012	2012/2007 %
Employment in agriculture, forestry and fishery	2,757	2,690	2,689	2,780	2,612	2,682	97.27
The share in the rural employment (%)	64.38	63.02	63.85	66.06	64.24	64.07	-
The share in the employment at the national level (%)	27.58	27.05	27.09	28.89	28.78	28.95	-

Source: Romania's Statistical Yearbooks, 2008-2013, Chapter 3. [9]

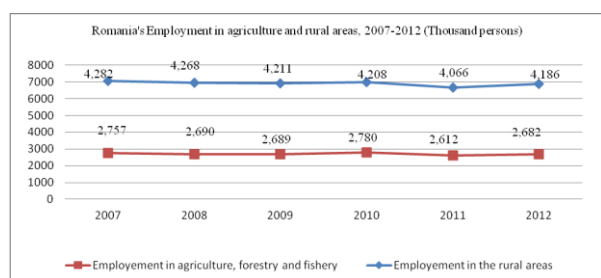

Fig.1. Dynamics of Employment in agriculture and in the rural areas, Romania, 2007-2012 (Thousand persons)

Source: Romania's Statistical Yearbooks, 2008-2013. Own design.

**The statistical parameters of employment in agriculture, forestry and fishery and in the rural areas** are presented in Table 5.

**The employment in agriculture- the highest in the country** compared to the employment in other economic branches such as: industry

(19.06%), trade (13%), constructions (7.50%) and transportation and storage (4.67 %). (Table 6).

Table 5. Statistical parameters of the employment in agriculture, forestry and fishery and in the rural areas, Romania, 2007-2012

Statistical parameter	Employment in agriculture, forestry and fishery	employment in the rural areas
Average	4,203.5	2,701.6
Standard deviation	76.956	59.868
Variance	5,922.3	3,584.2
Standard error	31.417	24.441
Minimum	4,066	2,612
Maximum	4,282	2,780

Source: Own calculations.

Table 6. The employment structure by activity in Romania's economy, 2012 versus 2007

Specification	Employment in 2007		Employment in 2012		2012/2007 %
	Thousand persons	%	Thousand persons	%	
Total economy, of which:	9,353	100.00	9,263	100.00	98.93
Agriculture, forestry and fishery	2,757	29.48	2,682	28.95	97.27
Industry	2,259	24.15	1,766	19.06	78.17
Trade	1,151	12.30	1,205	13.00	104.69
Constructions	679	7.25	695	7.50	102.35
Transport	489	5.22	433	4.67	88.54

Source: Romania's Statistical Yearbooks, 2008-2013, Chapter 3. [9]

More than this, the decline of the employment was deeper in industry (-21.83 %) and transportation (-11.46 %), but in the field of trade it increased by 4.69 % and in the field of constructions by 2.35 %.

**The structure of the employed population in agriculture, forestry and fishery by professional status.** If at the national level in the year 2012, there were 67.3 % employees

and 18.9 % self-employed people and 12.6 % contributing family workers, in the agricultural sector there were 49.09 % self-employed persons and 42.7 % contributing family workers, just 0.2 % employers and 7.2 % employees. In the year 2012 it was not observed so much change compared to 2007. (Table 7).

Table 7. The employment in agriculture, forestry and fishery by professional status compared to the employment in the national economy in 2012 versus 2007

Specification	Total employment (Thousand persons)	Of which, by professional status (%)			
		Employees	Employers	Self-employed persons	Contributing family workers
<b>In 2012</b>					
Employment in the economy	9,263	67.3	1.2	18.9	12.6
Employment in agriculture, forestry and fishery	2,682	7.2	0.2	49.9	42.7
<b>In 2007</b>					
Employment in the economy	9,353	66.2	1.5	19.7	12.6
Employment in agriculture, forestry and fishery	2,757	5.2	0.2	53.4	41.2
<b>Differences 2012-2007</b>					
Employment in the economy	-90	+1.1	-0.3	-0.8	0
Employment in agriculture, forestry and fishery	-75	+2	0	-3.5	+1.5

Source: Romania's Statistical Yearbooks, 2008-2013, Chapter 3.4. [9]

**The employment in the agricultural sector by age group.** In 2012, in the agricultural field of activity, 86.5 % of the employed people was between 15-64 years old compared to 95.9 % in the economy. In agriculture, 13.6 % employed people is over 65 years old compared to 4.1 % in the national economy.

Table 8. The employment in agriculture, forestry and fishery by age group compared to the employment in the national economy in 2012 versus 2007

Specification	Total employment (Thousand persons)	Total 15-64 years (%)	By age group (years) %					
			15-24	25-34	35-44	45-54	55-64	Over 65
<b>In 2012</b>								
Employment in the economy	9,263	95.9	7.0	26.2	30.6	19.9	12.2	4.1
Employment in agriculture, forestry and fishery	2,682	86.4	9.8	18.1	23.2	16.2	19.1	13.6
<b>In 2007</b>								
Employment in the economy	9,353	94.5	8.3	27.1	26.4	22.4	10.3	5.5
Employment in agriculture, forestry and fishery	2,757	82.5	9.3	23.3	20.5	28.3	19.2	17.5
<b>Differences 2012-2007</b>								
Employment in the economy	-90	+1.4	-1.3	-0.4	+4.2	-2.5	+1.9	-1.4
Employment in agriculture, forestry and fishery	-75	+3.9	+0.5	-5.2	+2.7	-12.1	-0.1	-3.9

Source: Romania's Statistical Yearbooks, 2008-2013, Chapter 3.3. [9]

About 35.3 % employed persons in agriculture were between 45-64 years compared to 32.1 % in the economy. Only 23.2 % employees in agriculture belong to the 35-44 year group compared to 30.6 % at the national level. In agriculture, only 18 % are young employees between 25-34 years old while in the economy there were 26.2 % (Table 8).

**The structure of the employment in agriculture, forestry and fishery by gender.**

In 2012, in the agricultural sector there were employed 46.4 % women compared to 65.2 % in 2007, meaning that men are more preferred by employers. Just 1.2 % women were employed in agriculture in 2012 compared to 18.7 % in 2007 and this means that the differences lost their jobs or retired.

If in 2007, 0.1 % of the employed people in agriculture were represented by women, but in 2012 there was none.

Also, the percentage of the self-employed

women declined from 16.7 5 in 2007 to 15.5 % in 2012. The contributing family workers of female gender remained with the same share, 29.7 % ( Table 9).

Table 9. The structure of the employment population by gender compared to the employment in the national economy in 2012 versus 2007

Specification	Total employment (Thousand persons)	Women (%)	Of which, by professional status			
			Employee	Employer	Self-employed persons	Contributing family workers
<b>In 2012</b>						
Employment in the economy	9,263	44.7	30.1	0.4	5.5	8.7
Employment in agriculture, forestry and fishery	2,764	46.4	1.2	0	15.5	29.7
<b>In 2007</b>						
Employment in the economy	9,353	45.3	30.2	0.3	5.6	9.0
Employment in agriculture, forestry and fishery	2,757	65.2	18.7	0.1	16.7	29.7
<b>Differences 2012-2007</b>						
Employment in the economy	-90	-0.6	-0.1	+0.1	-0.1	-0.3
Employment in agriculture, forestry and fishery	-75	-18.8	-17.5	-0.1	-1.2	0

Source: Romania's Statistical Yearbooks, 2008-2013, Chapter 3.4. [9]

### Romania's position in the EU regarding labor force and employment in agriculture.

In 2010, according to the EU Farm Structure Survey, Romania had 7,156.9 thousand persons directly employed in agriculture, representing 28.67 % of the EU-27 employment in agriculture. From this point of view, Romania comes on the 1st position in the EU-27. It is followed by Poland (15.23 %), Italy (13.59%), Spain (8.92%), Greece (4.85 %), Hungary (4.58%), France (4.06 %), all these 7 countries together assuring 80 % of the EU employment in agriculture.

Of the total number of persons employed in agriculture, 7,156.9 thousand persons, recorded by Romania, 53.5 % were sole holders, 45 % family members and 1.5 % non-family regular workers.

The percentage of sole holders, 53%, recorded by Romania, was by +6.9 % higher than the EU-27 average. Higher percentages were recorded by Malta ( 65.5 %), Greece (59.6%), Lithuania (53.7%) and the lowest percentage belonged to the Czech Rep. (14.9%).

The percentage of family members recorded by Romania, 45 %, was by -0.6 % less than the EU average. From this point of view Romania came on the 6th position in the EU-27. The highest percentages were registered by Slovenia (64.3 %), Portugal (50.9%), Poland (58.7%), Spain (48.9%), Cyprus (48%) and Italy (47.9%) and the lowest figure was recorded by France (16.4 %).

Regarding the non-family regular workers, Romania recorded 1.5 %, by -6.3 % less than the EU-27 average. This figure placed Romania on the last position in the EU-27.

Men working in Romania's agriculture accounted for 53.1 % of the EU employment in agriculture, this figure being by -4.6 % lower than the EU average. From this point of view, Romania is followed by Lithuania (49.6%), all the other EU countries having higher percentages regarding men employed in agriculture.

Concerning the average number of persons per holding, Romania recorded 1.9 persons, by -0.9 less than the EU-27 average.

With 0.9 % people working full-time in

agriculture, Romania came on the last position in the EU-27 and recorded by -13.4 % less than the average of the Community. In Romania 83 % of people is working in

small holdings with SO < Euro 4,000, a situation which placed the country on the penultimate position in the EU-27 (Table 10).

Table 10. Farm labour force (regular) in Romania compared to the EU-27 average in 2010

Specification	Total 1,000 persons	Of which			By sex Men (% of total)	Average workers per holding	Working in holdings with SO < Euro 4,000 (% of total)	Working full time (% of total)
		Sole holders (% of total)	Family members (% of total)	Non family regular workers (% of total)				
EU-27	24,960.4	46.6	45.6	7.8	57.7	2.1	73.1	14.3
Romania	7,156.9	53.5	45.0	1.5	53.1	1.9	83	0.9
Difference Romania- EU-27 average	-17,803.5	+6.9	-0.6	-6.3	-4.6	-0.2	-9.9	-13.4

Source: EU Farm Structure Survey. [4]

In 2012, according to the EU Labour Force Survey, Romania had 2,619.1 thousand persons employed in agriculture, being situated on the 1st position in the EU-27. The

lowest number of employed people in agriculture had only Malta (1.4 thousand persons).

Table 11. Romania's employment in agriculture compared to the EU-27 in 2012

Specification	Employment 1,000 persons	Men (% of total)	Persons aged 15-39 years (% of total)	Persons aged 40-64 years (% of total)	Persons aged 65 and over (% of total)
EU-27	9,947.9	61.5	33	57	9.9
Romania	2,619.1	52.7	38.8	47.2	13.9
Difference Romania- EU- 27 average	-7,328.8	-8.8	+5.8	-9.8	+4.0
Position occupied by Romania in the EU-27	1	27	4	25	7

Source: EU Labour Force Survey. [5]

Romania had the lowest percentage of men working in agriculture, 52.7 %, therefore it is situated on the 27th position in the EU-27. The 1st position is occupied by Ireland with 87.7 % men employed in agriculture.

With 38.8 % persons aged between 15-39 years of the total number employed in the EU-27 agriculture, Romania came on the 4th position, the 1st position being occupied by Denmark (43 %).

Romania registered 47.2 % employees belonging to the 40-64 years age group, percentage which placed it on the 25th

position in the EU-27. The 1st position is occupied by Denmark (46%), the lowest figures and the last position is occupied by Slovakia (73.1 %).

Regarding the percentage of persons aged 65 and over, employed in agriculture, Romania recorded 13.9 %, which positioned it on the 7th place. The 1st position, with the least number was occupied by Slovakia (0.4 %) and the last position for the oldest people employed in agriculture was occupied by Portugal (42.7%) (Table 11).

In 2010, according to the EU Farm Structure

Survey, Romania had 1,610.3 thousand persons labour force in terms of AWU, representing 16.49 % of the total labour force in the EU-27. From this point of view, Romania was followed only by Poland which registered 1,897.2 thousand AWU, all the other EU countries having less labour force in

agriculture.

Regarding the labour force working in holdings with SO < Euro 4,000, Romania recorded 64.7 %, being situated on the penultimate position in the EU-27, being followed only by Bulgaria (66.3%).(Table 12).

Table 12. Romania's Labour force in AWU compared to the EU-27 average in 2010.

Specification	Total labour force in AWU (1,000 AWU)	Of which (%)				By sex Men (% of total)	Average workers per holding (AWU per holding)	Working in holdings with SO < Euro 4,000 (% of total)
		Sole holders (% of total)	Family members (% of total)	Non family regular workers (% of total)	Non family non-regular workers (% of total)			
EU-27	9,761.2	45.1	32.5	14.7	7.8	60	0.8	30.6
Romania	1,610.3	49.3	39.4	4.5	6.8	54.3	0.4	64.7
Difference Romania-EU-27 average	-8,150.9	+4.2	+6.9	-10.2	-1	-5.7	-0.4	+34.1

Source: EU Farm Structure Survey. [4]

## CONCLUSIONS

The share of the rural population in Romania is 46 %, the highest in the EU-28.

The employment in the rural areas accounted for 4,186 thousand persons in 2012, representing 45.19 % of the employment in the national economy.

In 2012, in the agricultural sector there were 2,682 thousand persons employed, representing 64.07 % of the employed rural population and 28.95 % of the employment in the economy. It is higher than in the EU-28 where it is only 4.7 %. Also, it is the highest percentage compared to other economic sectors such as: industry, constructions, trade and transportation.

In agriculture, there are more employees and self employed people than in the national economy.

The population employed in agriculture is characterized by aging as a higher percentage is over 65 years old and also over 35 years, and just 18 % young people belonging to the 25-34 years group were employed in this sector compared to 26.2 % of the total employed persons in agriculture compared to 65.2 % in 2007, meaning that they lost their

jobs.

So, there was noticed a gender discrimination related to the occupancy degree of the job vacancies.

According to EU Farms Structure Survey, Romania's position in the EU-27 regarding labour force working in agriculture could be characterized as follows:

- Romania comes on the 1st position in the EU-27 regarding the number of persons directly employed in agriculture;

- Of the total number of employed persons in agriculture in Romania 53.5 % are sole holders, 45 % family members and 1.5 % non family regular workers.

- Also, of the total number of employed people in agriculture in Romania, 53.1 % are men, and from this point of view Romania is situated on the penultimate position in the EU-27.

- Romania is on the last position in the EU-27 for the people employed full time in agriculture (0.9%) and on the penultimate position for 83 % employed persons in small holdings SO < Euro 4,000.

According to the EU Labour Force Survey, of the total employed persons in agriculture, 38.8 % are persons between 15-30 years old, 47.2



% are between 40-64 years old and 13.9 % are of 65 and over.

In terms of AWU, Romania is placed on the top position for 1,610.3 thousand AWU and on the penultimate position for 64.7 % AWU working as employed in small farms SO<Euro 4,000.

As a final conclusion, Romania's agriculture is dominated by family farms, the most employed people being part-time in farm work having other jobs and income sources, agricultural works are achieved in small farms, the employed population is aging, the young people is not attracted by agriculture looking for better paid jobs in the cities or abroad.

The solutions to improve the employment in agriculture are the following ones:

- to diversity the activities in the rural areas and create new jobs with a positive impact on the local population income ( agro-tourism, other services);
- to stimulate the young people to work in the rural areas;
- to support women to develop specific activities and involve them much more in the preservation of the traditions, folklore, local gastronomy, handicrafts etc;
- to offer funding for developing new activities, investments for the young farmers to develop their business, training and managerial skills.

## REFERENCES

- [1]Burja Vasile, 2014, Some aspects of employment in Romania's agriculture on the European context, *Annales Universitatis Apulensis Series Oeconomica*, 16(1), 2014, 41-51
- [2]Condei Reta, Mocuta Dorina, Popescu Agatha, Turek Adrian, 2015, The importance of assessing human resources for the sustainable development- A study case, South West Oltenia Region, *Scientific Papers Series Management, Economic Engineering in Agriculture and Rural Development*, Vol.15(1):105-129
- [3]Dumitru Mihail, Diminescu Dana, Lazea Valentin, 2004, *Rural Development and the Reform of Romanian Agriculture*, Romanian Center for Economic Policies.
- [4] EU Farm Structure Survey, [http://epp.eurostat.ec.europa.eu/portal/page/portal/farm\\_structure\\_survey/introduction](http://epp.eurostat.ec.europa.eu/portal/page/portal/farm_structure_survey/introduction)
- [5]EU Labour Force Survey, [\[oyment\\\_unemployment\\\_ifs/introduction\]\(http://epp.eurostat.ec.europa.eu/portal/page/portal/employment\_unemployment\_ifs/introduction\)](http://epp.eurostat.ec.europa.eu/portal/page/portal/empl</a></li></ul></div><div data-bbox=)

[6]How many people work in agriculture in the European Union? An answer based on Eurostat data sources, *EU Agricultural Economics Briefs* No 8, July 2013, [http://ec.europa.eu/agriculture/rural-area-economics/briefs/index\\_en.htm](http://ec.europa.eu/agriculture/rural-area-economics/briefs/index_en.htm)

[7]Popescu Agatha, 2013a, Considerations on the Rural Population as a Resource of Labour Force in Romania, *Scientific Papers Series Management, Economic Engineering in Agriculture and Rural Development*, Vol.13(3):229-236

[8]Popescu Agatha, 2013b, Considerations on the main features of the agricultural population in the European Union, *Scientific Papers Series Management, Economic Engineering in Agriculture and Rural Development*, Vol.13(4):213-220

[9]Romania's Statistical Yearbooks, 2008-2013. National Institute for Statistics, [ww.insse.ro](http://www.insse.ro)

[10]Socio-economic analysis in the prospect of the rural development 2014-2020, MARD, Authority of Management for NPRD, [http://www.madr.ro/docs/dezvoltare-rurala/Descrierea\\_generala\\_a\\_situatiei\\_economice\\_actuale\\_4\\_11\\_2013.pdf](http://www.madr.ro/docs/dezvoltare-rurala/Descrierea_generala_a_situatiei_economice_actuale_4_11_2013.pdf)

[11]Tocco Barbara, Davidova Sophia, Bailey Alastair, 2014, Labour adjustments in agriculture: evidence from Romania, *Studies in Agricultural Economics* 116 (2014) 67-73



## THE IMPACT OF AGRICULTURAL EDUCATION SYSTEM ON THE IMPROVEMENT OF THE RURAL LABOUR MARKET SITUATION

Veronica PRISĂCARU, Tatiana SEVCIUC

State Agrarian University of Moldova, 44, Mircesti str., MD-2049, Chisinau, Republic of Moldova, 0 373 22 31 22 06, Emails:v.prisacaru@uasm.md; sevcuictatiana@mail.ru

*Corresponding author:* v.prisacaru@uasm.md

### *Abstract*

*The main propose of this article was to reveal the persistent dependence between the value of agricultural education and rural labour market indicators. The rural labour market investigations denoted negative trends of young people employment. One of the rural labour market greatest problems is the lack of attractiveness for well-qualified young people. Along with other factors, agricultural education represents an effective tool to improve the labour market situation in the rural space. According to the employers' questionnaires, there are some problems related to young people ability to integrate their theoretical knowledge in practical contexts. Another problem concerns the low level of knowledge and lack of practical skills in starting up a business. These conclusions emphasized the necessity of curriculum improvement in the higher education system, modernization of the educational technology and establishment of effective collaborations with enterprises.*

*Key words:* agricultural education, knowledge, labour market, practical skills, young people evolution.

### INTRODUCTION

Achieving the objective of sustainable economic and social development in the Republic of Moldova is not possible without a very thorough and multilateral approach of the professional education system in close correlation with the economic system of the country. It cannot be ignored that higher education institutions of the Republic of Moldova are permanently subject to very strict assessment, which estimates the quality of performed duties: education, science, extension. Implicitly, the academic and academic-scientific staff of those institutions is regularly evaluated according to quite severe criteria.

The purpose of studies, in its turn, is expressed in knowledge and skills, which are assessed during the intermediary and final evaluations according to different forms.

Apparently, the monitoring of the vocational education system is performed continuously and it is very severe. The dilemma is: why, despite of continuous efforts to modernize the curricula, increase the professionalism of the academic and academic-scientific staff, improve the educational technologies, etc., the level of economic and social development of

the country is still very low? The answer is simple: the education system must be a business oriented one, flexible to any change in its environment and capable of providing that product, which is required by the business environment. Implicitly, the value of graduates' knowledge should be estimated in terms of its effects on business performance and, as a result and on the labour market indicators.

### MATERIALS AND METHODS

As a material for this investigation the authors used some data presented in previous studies on the labour market in rural areas and, especially, on the youth employment [3],[4],[5], statistical data related to the dynamics of bachelor's and master's degree graduates in „Agricultural Sciences” and „Veterinary Medicine” in the Republic of Moldova in the period 2007-2013 and also related to the obtained agricultural products per person employed in the period 2007-2013, and also the conceptual approaches of the notion of knowledge.

The used methodological tools included: analysis, systematization, generalization, formulation of authors' conclusions and

judgments on the problems related to knowledge valorization by the graduates of agricultural specialties and the interaction of universities with the business environment.

## RESULTS AND DISCUSSIONS

Conceptual elucidation of the vocational education value can be achieved starting from the concept of value of knowledge.

By synthesizing several approaches we found out that knowledge is a familiarity, awareness, and understanding of someone or something, such as facts, information, description or skills, which is acquired through experience or education by perceiving, discovering or learning. Thus we conclude that by knowledge we cannot designate only the perceived and memorized information, but also the ability of implementing it into practice. This is clearly confirmed by other definitions of knowledge: “knowledge is generally thought of as being “know how”, applied information, information with judgement or the capacity for effective action” [2]; knowledge is information transformed into capabilities for effective action. In effect, knowledge is action” [1].

Thus we could state that the value of knowledge is estimated by its impact on the activity where applicable, by the added value that it can generate. Therefore, the value is not an intrinsic property of knowledge, the value of knowledge depends entirely on how it is used. In this context we note that vocational education supposes the acquisition by future specialists of a certain volume of knowledge and practical skills constituting the potential that the educational institution graduates bring when taking their first steps into work. We could also identify them as the value of knowledge provided by the institution which, in its turn, often mistakenly addresses, being associated with graduates’ success. In fact, it is not so important how we evaluate, but *why we choose to evaluate in a way or in another?* A thoughtful evaluation mechanism would allow each educational institution to get oriented to certain purposes and to take actions in order to achieve those purposes. And if we refer to vocational education

institutions including universities, it is clear that the estimation of knowledge value should be carried out through its impact on the business environment, this impact mediating ultimately the influence on the labour market indicators. This statement is confirmed by the following: the impact on business is done by graduates’ employment in the given environment. Therefore, they fall among the persons employed in a segment or another of the labour market, which implies some influence on the quantitative, structural and quality indicators of the labour market.

In order to justify the above mentioned statements, it is sufficient to try to find an answer to the following question: why do we have so many graduates with high average scores but the level of economic and social development of the country is so low? The problem is even worse if we consider the rural areas. Thus, under conditions when higher education institutions annually have numerous promotions of specialists, the employment of young people with higher education degrees in rural areas is done very slowly. Simultaneously, considering that the graduates of agricultural specialties are the ones who should manage the agricultural businesses which are prevalent in rural areas, we find an insufficient level of development there. Finally, the macroeconomic indicators reflecting the effectiveness of human resource management in rural areas are extremely low.

In order to support the above-mentioned statements, we shall refer to a number of indicators reflecting the changes on the labour market in the rural areas of the Republic of Moldova in the period 2007-2013 in relation to the dynamics of bachelor’s and master’s degree graduates in the fields related to agriculture: „Agricultural Sciences” and „Veterinary Medicine”.

By examining the dynamics of the number of graduates of the specialties mentioned above (Fig.1), we observed a visible ascending indicator in recent years (2011-2013).

As a result, the number of graduates in 2013 is higher than in 2007 by 43%. At the same time, if we examine the dynamics of the number of graduates with higher education under the age of 34 years employed in

agriculture [6], we find that their share in the total number of specialists with higher education, even following a growing trend,

remains at a very low level, being only 32% in 2013.

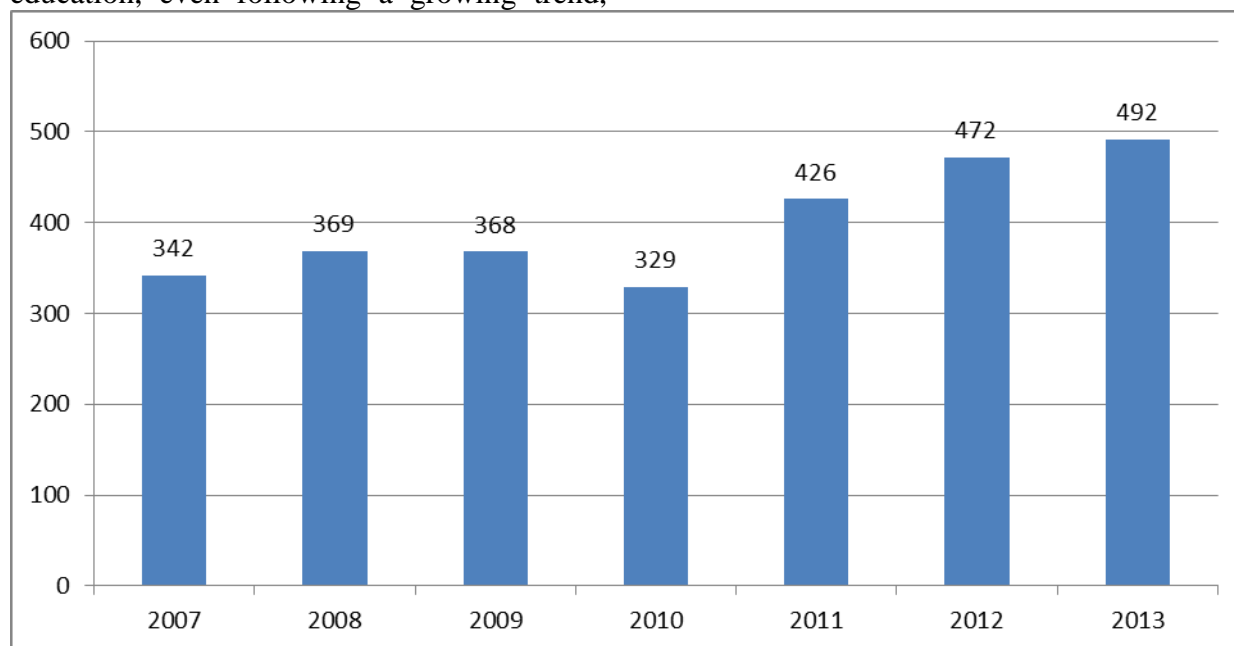

Fig. 1. Dynamics of the bachelor's and master's degree graduates in the fields of „Agricultural Sciences” and „Veterinary Medicine” in the Republic of Moldova in the period 2007-2013

Therefore, 68% of the total number of specialists with higher education employed in agricultural activities is aged over 35 years, which confirms the conclusions of a series of other studies on the attractiveness of this branch for young graduates of higher education institutions specialized in agriculture [3], [4], [5].

Another important indicator of the workforce management is the obtained agricultural production from an employed person (Fig. 2). According to Figure 2, we could see an important increase in the value of agricultural production obtained from a person employed in agriculture during the considered period. But if we refer to the actual size of the obtained indicators, we realize that it remains at a very low level. For example, in 2013, the average annual salary of an employee working in the field of „information and communication” was 88 653 MDL, and in the field of „finance and insurance” - 84 195 MDL. Therefore, we can conclude that even

the salaries obtained in the mentioned fields exceed labour productivity in agriculture by 4.36 and 4.14 times respectively.

This is already an argument supporting the statement that the income in the field of agriculture is very low and, along with low salaries, it cannot motivate the young graduates to get employed into the branch. On the other hand, the prosperity of agricultural production and hence, of the rural areas, cannot be achieved without the involvement of the human factor in increasing the efficiency of the economic activities management. We conclude, therefore, that there is a vicious cycle that generates the following dilemma: what is to be done to solve the problem of rural areas? What are the main decision making factors that may arise in this issue in order to attract young professionals in rural areas and optimally exploit their potential? The deeper investigation of this topic highlights the necessity for a series of actions.

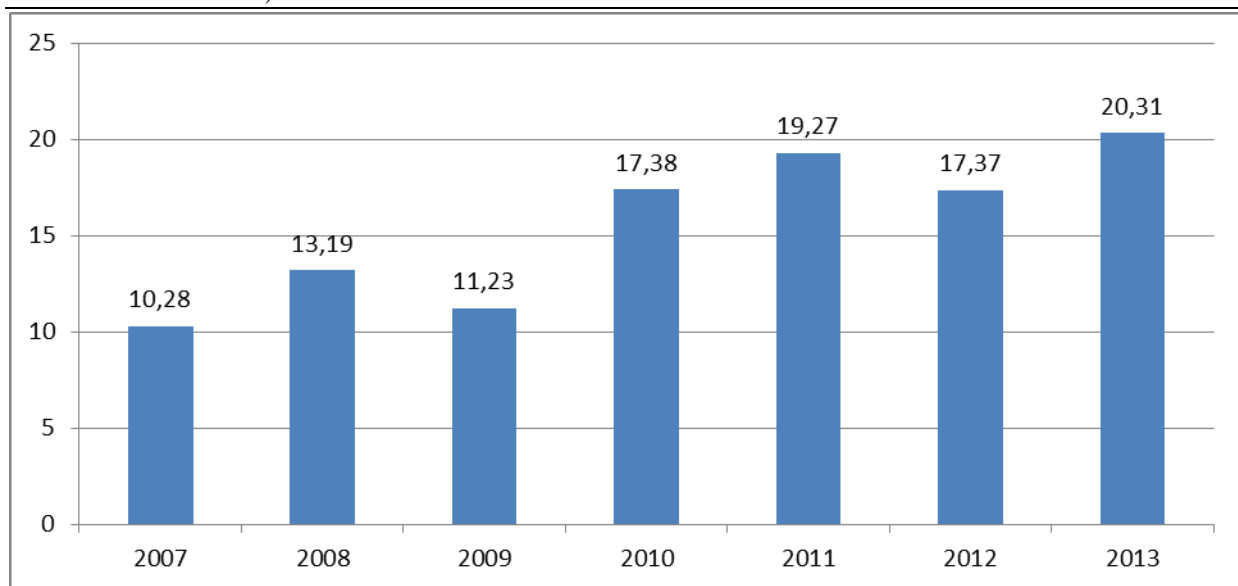

Fig. 2. The agricultural production (at current prices) obtained from an employed person in the period 2007-2013

First, given that the main demotivating factor for young people is the reduced possibility to make a career and, therefore, to achieve their professional ambitions and to secure a decent living [5], the educational institutions have to convince the young people that there are still possibilities to make a career. It is also necessary to put more emphasis on the development of the entrepreneurial skills and investigative capacity, which would change students' opinions on rural issues, on their theoretical and practical training for business and on the reduction of psychological impediments.

This implies, in its turn, a series of complementary actions to those already implemented: the modernization of study content by putting a greater emphasis on business related issues; undertaking further efforts to train students skills in market investigation, improving decisions under risk and uncertainty, risk management, financial and economic diagnostic of the enterprise activity; promotion of prosperous businesses, thus demonstrating to students that there are opportunities and real prerequisites for success in one area or another; instilling the idea that any success could be reached only by planned efforts etc.

Another important factor is the interaction of universities with business environment. On the other hand, businesses must also contribute to the optimization of synergies

between vocational education and practical work. The correlation between these two important components of society: higher education and business environment is presented schematically in Figure 3.

It is clear that achieving the optimum level of such interactions would have multiple effects on both the training system of future specialists and the business environment. However, it is necessary to recognize that the availability of these two components - university-business - for cooperation, is different. The universities, activating under competition, being subject to very rigorous and demanding assessments, by linking their activities to the quality management system requirements, need, somehow, to make permanent attempts of cooperation with enterprises in various aspects. Unfortunately, the enterprises still show a low or even the lack of such an interest.

Thus, the conclusion of agreements concerning the performance of student internships in different enterprises, the participation of enterprise representatives in certain meetings organized within universities, their involvement in certain activities related to curricula improvement often become very difficult because of the categorical refusal of the enterprise managers and specialists. In these circumstances, the task to get students closer to business environment becomes difficult to carry out

because of businesses' refusal to cooperate.

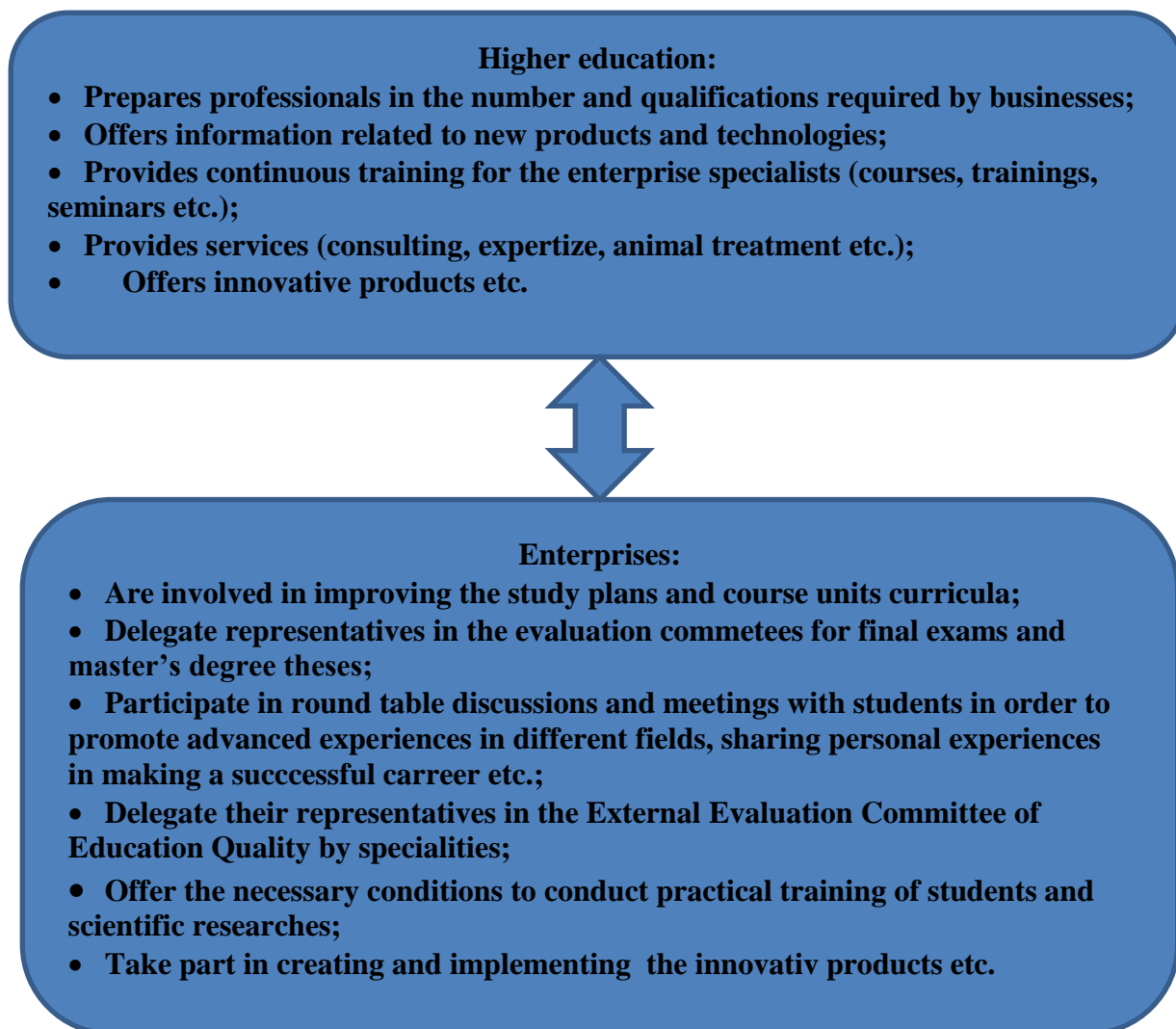

Fig. 3. The correlation between higher education and business environment

As a result, the task to orient professionally State Agrarian University of Moldova graduates to rural business environment lies entirely on the responsibility and enthusiasm of the university's academic and scientific staff.

Considering the above-mentioned facts, it is clear that the state must find some mechanisms to motivate enterprises to cooperate with universities: either establishing through legislation the obligation to create special funds for innovative laboratories or through tax incentives in situations when special means are allocated for innovations or other measures that „would wake up” the economic units and would switch them to cooperate with the vocational education system. Even if these relationships work

naturally in the economically developed countries, without being catalyzed by the state, we should recognize that in the Republic of Moldova, a country that has stepped into the market economy not so long ago, many managers still have set their mind on immediate results, on the fear of everything is new and unusual and on conservatism. Another mentality problem is the fact of not recognizing that, in addition to strictly determined responsibilities arising from the employment contract, there are also certain civic obligations.

## CONCLUSIONS

The assessment of knowledge value acquired in vocational education should be done in

terms of its impact on business environment, this impact mediating ultimately the influence on the labour market indicators.

Despite the representative number of bachelor's and master's degree graduates in the agricultural areas, the employment of young people with higher education in rural areas is done very slowly.

Tackling the problem of youth employment in the rural areas and hence, the economic development of those areas and improving labour market indicators requires, on the one hand, the modernization of training in universities and on the other hand – close collaboration with the business environment.

By examining the attitude of enterprise managers and specialists towards universities proposals for cooperation, one could note a very low responsiveness to them.

It is required some state intervention in the economic agents' motivation for a closer cooperation with universities through various mechanisms: tax incentives, establishing through legislation the obligation to create special funds for innovative laboratories etc. Finally, the results of such collaboration, due to its beneficial effects on the economic performance of enterprises, would provide added value to vocational education.

Employment difficulties experienced by young people in the rural areas of the Republic of Moldova, *Scientific papers. Series „Management, Economic Engineering in Agriculture and Rural Development”*, 14 (2): 235-240. [6] [www.statistica.md](http://www.statistica.md). Statistici pe domenii.

## REFERENCES

- [1] Myrray P.C. (Corporate Education. Biz). New language for new leverage: the terminology of knowledge management. Core concepts of knowledge management. <http://www.ktic.com/topic/6/13/TERM2/HTM>
- [2] NHS National electronic Library for Health. Knowledge management glossary. [http://www.neth.nhs.uk/knowledge\\_management/glossary/glossary.asp](http://www.neth.nhs.uk/knowledge_management/glossary/glossary.asp)
- [3] Prisăcaru, Veronica, 2013, Evolutionary aspects of the welfare of the rural population in the Republic of Moldova and their motivational implications, *Scientific papers. Series „Management, Economic Engineering in Agriculture and Rural Development”*, 13 (4): 235-238.
- [4] Prisăcaru, Veronica, Şevciuc, Tatiana, 2013, Trends of the rural labour market and agricultural human potential evolution under the influence of demographic phenomena in the Republic of Moldova, *Scientific Papers. Series „Management, Economic Engineering in Agriculture and Rural Development”*, 13 (3): 341-346.
- [5] Prisăcaru, Veronica, Şevciuc, Tatiana, 2014,



## EDUCATIONAL MANAGEMENT IN THE FIELD OF LIFE SCIENCES - KEY COMPETENCES NEEDED TO START AND DEVELOP THE INNOVATIVE SME'S

Nicoleta RADU<sup>1</sup>, Ana Aurelia CHIRVASE<sup>1</sup>, Narcisa BABEANU<sup>2</sup>, Ovidiu POPA<sup>2</sup>

<sup>1</sup>I.N.C.D.C.P. Bucharest, Biotechnology Department, 202 Splaiul Independentei Street, Bucharest, Romania, Phone: +40730.728.694 E-mail: nicolbiotec@yahoo.com

<sup>2</sup>University of Agricultural Sciences and Veterinary Medicine of Bucharest, 59 Mărăști Blvd, District 1, 011464, Bucharest, Romania, Phone: +40374.022.802; E-mail: secretariat@biotehnologii.usamv.ro

*Corresponding author:* nicolbiotec@yahoo.com

### Abstract

*The goal of the paper was to elaborate the basic template regarding the entrepreneurship key competences needed to start and develop innovative SMEs. Key competences were established based on the Field Survey Method using questionnaires, distributed to a sample of 100 entrepreneurs or individuals who would like to develop their own business and company. Based on the survey analysis, received from the 100 respondents, the Matrix of Competency was validated. So according to this, the ideal candidate to manage a company operating in the field of life sciences must be an independent person (81%), with ability to work in the multidisciplinary teams, and has the capacity to communicate his/her own ideas (92%). This person should have the capability to take the risk (77%), to feel the business opportunity, to take the initiative (83%) and to draw decisions based on limited information (74%). As a result of the responses received, the matrix of competency, developed as a questionnaire, has been validated and will be used to the selection of persons who wish to become entrepreneurs in order to manage the business in the fields of the life sciences.*

*Key words:* entrepreneurship matrix, key competences

### INTRODUCTION

Entrepreneurship is of critical importance to the modern economy. Researchers have studied entrepreneurship for decades. In recent years, significant relationship between entrepreneurial competencies and firm performance has been reported. Applying the competency approach, it was assumed that entrepreneurial competency differentiates entrepreneurs from non-entrepreneurs. Competencies are assessed in terms of actual behaviour observed in the workplace and are usually defined in terms of underlying personal characteristics like traits, knowledge, skills and attitudes. According to the literature [4,5,6,7,8,9,10] the biotech entrepreneur is unique from all other entrepreneurs, as he/she voluntarily leaves the comfortable world, and steps into an industry that carries uncertainties and risks unique to any other business. Entrepreneurs should be sure they possess these characteristics if they are going to start a

biotech company, because they will need them, when they face the many challenges during company development. In the competitiveness model for SME's, [1, 2, 3] distinguishes four major constructs: entrepreneurial competencies, competitive scope, organizational capabilities, and firm performance. The competitive scope and organizational capabilities represent the constructs of external environmental factors and internal firm factors, respectively. Central to the model are the relationships between entrepreneurial competencies and other constructs. In a market system, sustainable development requires sustainability innovation and entrepreneurs who can achieve environmental or social goals with superior products or processes that are successful in the marketplace of mainstream customers. Market innovations driving sustainable development do not necessarily occur by accident, but can be created by leaders who put them into the core of their business

activities.

Actors and companies making environmental progress to their core business can be called sustainable entrepreneurs. The framework for sustainable entrepreneurship which so far has covered business approaches with a strong inclusion of sustainability issues is further developed by including social entrepreneurship, i.e. the application of the entrepreneurial approach towards the primary goal of meeting societal goals.

Sustainable entrepreneurship is in essence the realization of sustainability innovations aimed at the mass market and providing benefit to the larger part of society.

As a consequence, sustainable entrepreneurship - defined in a narrow sense - deals with a very innovative company start-up supplying environmentally and/or socially beneficial products and services with the potential to conquer a large part of the market. The innovator role requires an ability to identify new market, organizational, or technological opportunities and combine new or existing resources in unique and creative ways. Competence in this role will be positively related to the degree of domain-specific knowledge, cognitive ability, creativity, conscientiousness, and openness to new experience. Conscientiousness is associated with intrinsic motivation and persistence, while openness to new experience is associated with the willingness to seek new knowledge from diverse sources. These two personality characteristics are contributing factors to individual creativity that, when combined with high levels of cognitive ability and domain-specific knowledge, can be expected to provide the foundation for innovative competence. Four behaviours are associated with brokering competence: exploration of diverse knowledge domains; learning from these multiple knowledge domains; linking knowledge from diverse domains to solve novel problems; and implementing ideas.

## MATERIALS AND METHODS

This research work was developed within the project entitled "IMPROVED CURRICULA

AND MODERN LEARNING SYSTEM TO PROMOTE THE NEW DIRECTIONS OF BUSINESS ENHANCEMENT IN LIFE SCIENCES APPLICATIONS". One important step during its running, it was the elaboration of a "Basic template regarding the entrepreneurship key competences needed to start and to develop innovative SMEs in the bio economic sector".

Key competences were established on the basis of Questionnaires, at which were invited to respond the people who have entrepreneurial skills or they who have or want to have their own company.

Table 1. Personality characteristics

Characteristics	DESCRIPTION
Risk seeking/ tolerance	The capacity to accept and to like risks, when they are needed to take steps towards new achievement.
Self-confidence	Feeling able to do something, having a positive perception of one self, being certain of one's potential, expressing one's point of view even if it diverges from the prevailing opinion.
Self-efficacy	The extent or strength of one's belief in one's own ability to complete tasks and reach goals.
Strong sense of independence	The ability to take responsibility for one's actions without unnecessary reliance on the help of others.
Self-made/ self-belief	The belief in own abilities: self-assurance or a persuasion in own capacity to succeed
Inventive orientation	The continuous pursuit of new technological ideas and business opportunities
Optimistic orientation	The belief that one's life outcomes are controlled by internal factors, such as ability, instead of external factors, such as powerful others' influence or chance.
Competitive spirit	The liking of competition or inclination to compete, characteristic to people who are enthusiastic about the competition and often seeking this type of competitive atmosphere in whatever they do and always up for a challenge.
Courageous and well organized	Bravery spirit, the capacity to face dangerous situations, pains, difficulties without fear together with the characteristic to be orderly and efficient, to plan and execute one's activities efficiently;
Communication capacity	Characteristic determined by efficient transfer of information to others and linked to active & empathetic listening
Networking ability	Capacity for interpersonal relationships (social and emotional intelligence), persuasion and networking, based on the understanding of relationships and networks' roles
Management capacity	The potential to gather and strengthen knowledge and competencies in four main areas needed for a start-up enterprise or an existing SME, with an impact on a firm's profitability: (1) Strategic and management knowledge aspects (2) Understanding the running of the business and of the potential opportunities or threats; (3) Willingness to question and review the established patterns (4) time in management development.
Leadership characteristics	The leadership can be defined as a process of "using no coercive influence to direct and coordinate activities of the members of an organized group toward the accomplishment of group objectives".
Capacity to work in multi-and cross-disciplinary teams	The potential to understand and integrate multi-disciplinary and cross disciplinary knowledge or competencies together with the capacity to good collaboration with people with complementary or different backgrounds
Adaptation to changing conditions	The potential to understand that only this continuous orientation can assure the business long run.
Training model:	Self-help, better coaching or mentoring

Source: [4, 7, 9]

Of the responses received, only 100 were selected as valid answers (i.e. people working in the life sciences, and are younger than 44 years). The structure of the Questionnaire is presented in Table 1 and Table 2.

Table 2. Skills and abilities

Crt. No.	Skills and abilities	Development model	Specific assessment test
1	Organizing associations / networks	Integration of formal and informal learning, meaning especially: e-learning, webinars, training videos, case studies, learning by doing training, peer-to-peer communication, meetings and visits, cross training, supervision, exploration, documentation	Follow-up questionnaires and surveys; follow-up interviews; follow-up focus group; observing participant on the job; monitoring specific performance data; action planning and specific follow-up assignment; organizing follow-up session; simulation methods and context.
2	Recognizing opportunities based on innovation		
3	Initiative orientation		
4	Decision making		
5	Creative thinking		
6	Determination		
7	Quick and forward judgment		
8	Persuasion spirit		
9	Hard working		
10	Holistic management		
11	Achievement orientation		
12	Imaginative use of knowledge		
13	Leading R & D activities		

Source: [4, 7, 9]

## RESULTS AND DISCUSSIONS

Analyzing the responses obtained from questionnaires received, we found that:

***In terms of personality characteristics*** (Figure 1) required of an entrepreneur, we found the following:

- 81% of respondents have business ideas and are determined to be independents;
- 74% of respondents are able to coordinate new projects or a new company;
- 95% of the respondents have the ability to work in multidisciplinary teams;
- 77% are people who like to take risks;
- 90% of respondents are people who like to compete with others;
- 92% of respondents are able to communicate their ideas.

***In terms of abilities and skills required of an entrepreneur*** (Figure 2), it was found that:

- 83% of respondents perceive correctly the business opportunities based on innovative processes;
- 81% of respondents are determined to be independents;
- 86%of respondents have the ability to use their knowledge in a imaginatively way;
- 74% of respondents are able to make the

right decisions, based on limited information;  
 - 83% of respondents are people with initiative.

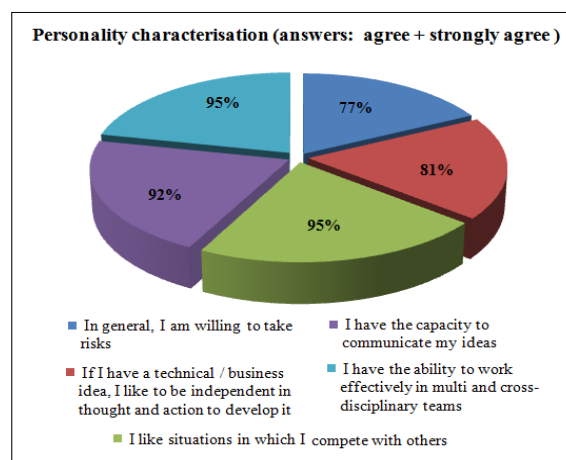

Fig.1. The main personality characteristics of Entrepreneurs

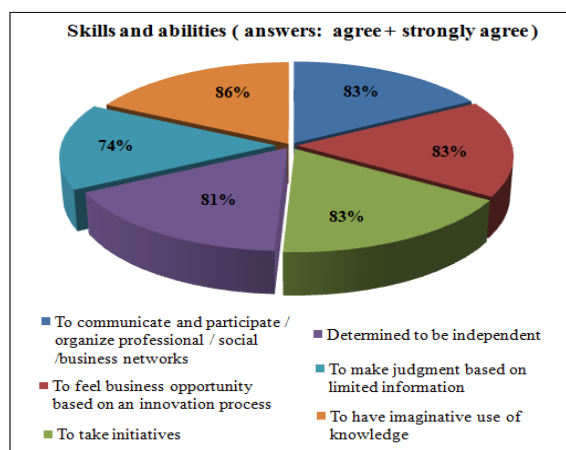

Fig.2. The main skills and abilities characteristics of Entrepreneurs

As a result of the responses received the matrix of competency, developed as a questionnaire, has been validated and will be used to the selection of persons who wish to become entrepreneurs, in order to manage the business from the fields of the life sciences.

## CONCLUSIONS

Based on survey analysis, received from 100 respondents, the part of Matrix of Competency regarding personality, skills and abilities characteristics was validated; so according to this, the ideal candidate to managed of the company which activate in the field of life sciences must be a persons which are determined to be independents (81%),

with ability to work in the multidisciplinary teams, and which have the capacity to communicate the own ideas (92%). These persons have the capability to take the risk (77%), to feel the business opportunity, to take the initiative (83%) and to make decisions based on limited information (74%).

## ACKNOWLEDGEMENTS

The paper was supported by the project entitled: *"IMPROVED CURRICULA AND MODERN LEARNING SYSTEM TO PROMOTE THE NEW DIRECTIONS OF BUSINESS ENHANCEMENT IN LIFE SCIENCES APPLICATIONS"*, Lifelong Learning Programme Leonardo da Vinci - Transfer of Innovation, project no: 2013-1-RO1- LEO05-28758. This publication reflects the views only of the author, and the Commission cannot be held responsible for any use which may be made of the information contained therein

## REFERENCES

- [1]Abratt, R., Bendixen, M., Opoku, R. A., Pitt, L. 2007, Communicating brand personality: Are the web sites doing the talking for food SMEs? Qual. Market Res.: Int. J., 10: 362–374.
- [2]Alford, B. L., Hayes, J. B., Silver, L., York, R. P., 2006, Looks matter in developing consumer-brand relationships. J. Prod. Brand Manag., 15 (5): 306–315.
- [3]Chan K.F., Man Y., Thomas W.Y., Theresa, 2002, The competitiveness of small and medium enterprises, a conceptualization with focus on entrepreneurial competencies. Journal of Business Venturing, 17: 123–142.
- [4]Leutner, F. G., Ahmetoglu, R., Akhtar, T.C., 2014, The relationship between the entrepreneurial personality the Big Five Personality traits, Personality and Individual Differences, 63, 58-63.
- [5]Merrilees, B., Wong, H. Y., 2005, A brand orientation typology for SME's: A case research approach., J. Prod. Brand Manag. 14 (3):155–162.
- [6]Neuman, W. L., 2003, Social Research Methods – Qualitative and Quantitative Approaches, 5th edn, Pearson Education, Boston.
- [7][www.forbes.com/2010/08/02/entrepreneur-personality](http://www.forbes.com/2010/08/02/entrepreneur-personality).
- [8][www.davincimethod.com/entrepreneur-test](http://www.davincimethod.com/entrepreneur-test).
- [9] [www.potentielentrepreneur.ca/client/questionnaire](http://www.potentielentrepreneur.ca/client/questionnaire).
- [10]Xu, B., 2006, Market differential evaluations of strategic alliances in the pharmaceutical/biotech industry, J. High Technol. Manag. Res., 17, 43–52.

## EDUCATIONAL MANAGEMENT IN THE FIELD OF LIFE SCIENCES - BLENDING LEARNING FOR BIOENTREPRENEURS TRAINING

Nicoleta RADU<sup>1</sup>, Ana Aurelia CHIRVASE<sup>1</sup>, Narcisa BABEANU<sup>2</sup>, Ovidiu POPA<sup>2</sup>

<sup>1</sup>I.N.C.D.C.P. Bucharest, Biotechnology Department, 202 Splaiul Independentei Street, Bucharest, Romania, Phone: +4073.072.86.94; E-mail: nicolbiotec@yahoo.com

<sup>2</sup>University of Agricultural Sciences and Veterinary Medicine of Bucharest, 59 Mărăști Blvd, District 1, 011464, Bucharest, Romania, Phone: +4021.318.25.64, Fax: + 4021.318.25.67 Email: secretariat@biotehnologii.usamv.ro

**Corresponding author:** nicolbiotec@yahoo.com

### Abstract

*The paper aimed to develop a curriculum to be delivered to a target-group. The methodology used in the training of the target group was represented by the field survey analysis, which contains specific questions for the entrepreneurs from the field of life sciences. The survey analysis revealed that 97% of the respondents were interested to accumulate technical skills and knowledge regarding Business Management. Taking into account the respondents' wishes and expectations, and the usual methods used in this case, it was concluded that the most adequate method to develop and deliver the content of curriculum within the BELA project is to use the both learning methods: the face to face model, and the e-learning model; therefore, a blending learning methodology. The structure of the Blending learning package developed within the BELA project included: (i) the training content named "Enterprise business and intellectual property in life sciences, which is entirely adapted as e-learning, and (ii) the training content of "Sustainable Life Sciences Applications", which is adapted as a blending learning product.*

**Key words:** *blending learning, life science, training*

### INTRODUCTION

Blending learning (BL) is the combination of instruction from two historically separate models of teaching and learning: traditional face-to-face learning systems and distributed learning systems. It also emphasizes the central role of computer based technologies in blended learning. BL is combining online and face-to-face instruction. It combines face-to-face instruction with computer-mediated instruction. There are many reasons that an instructor, trainer, or learner might pick blended learning over other learning options. Allen, Graham and Osguthorpe [1,2,3] identified six reasons that one might choose to design or use a blended learning system: (1) pedagogical richness, (2) access to knowledge, (3) social interaction, (4) personal agency, (5) cost-effectiveness, and (6) ease of revision. Beyond this general statement, Allen, Graham, and Ure [3] found that, overwhelmingly, people chose BL for three reasons: (1) improved pedagogy, (2) increased

access and flexibility, and (3) increased cost-effectiveness. As part of this research they surveyed a wide range of companies, asking a structured set of questions to build up a picture of how they use blended learning and the trends they are seeing, as well as to gather examples of best practice and learning. The popularity of the learning methods used tended to mirror the more general responses. Changing business environments and global market crisis are challenging SMEs in every country. In order to keep pace with these challenges SME must:

- be innovative
  - be able to manage knowledge
  - have well qualified staff.
- Steed [4] mentions following benefits of collaborative blended learning in SME:
- Shorter and more focused courses;
  - Courses more interactive and collaborative;
  - Greater opportunity to practice either in groups or individually;
  - Ability to share with other learners;
  - Ability to learn without having to leave the

place of work;

- Ability to learn at a convenient time.

Six major issues are relevant to designing blended learning systems: (1) the role of live interaction, (2) the role of learner choice and self-regulation, (3) models for support and training, (4) finding balance between innovation and production, (5) cultural adaptation, and (6) dealing with the digital divide. **The Role of Live Interaction.** Under what conditions is human interaction important to the learning process and to learner satisfaction with the process? When CM (computer-mediated instruction) and face-to-face elements were combined, learners often placed a greater value or emphasis on the face-to-face aspects of the experience. **Models for Support and Training.** There are many issues related to support and training in blended environments, including (1) increased demand on instructor time, (2) providing learners with technological skills to succeed in both face-to-face and CM environments, and (3) changing organizational culture to accept blended approaches. There is also a need to provide professional development for instructors who will be teaching online and face-to-face. It is important to see more successful models of how to support a blended approach to learning from the technological infrastructure perspective as well as from the organizational (human) perspective.

**Digital Divide.** The divide between the information and communication technologies available to individuals and societies at different ends of the socioeconomic spectrum can be great Yet e-learning is a strategy that might be considered for Blended Learning Systems educating the learners because of its low cost and ability to be distributed widely. **Cultural Adaptation.** What role can and should blended approaches play in adapting materials to local audiences? One strength of e-learning is the ability to distribute uniform learning materials rapidly. Yet there is often a need for customizing the materials to the local audience to make them culturally relevant.

## MATERIALS AND METHODS

In order to establish the methodology which will be used in the training of target groups regarding business management in the life sciences, we used a survey analysis, regarding the needs and expectation of the target group. The survey analysis used here are based on answers to some specific questions, at which were invited to responds the persons which comprise researchers who are preparing to pass from research to business sector, managers of company which activate in the fields of life sciences and teachers involved in training of business management. All the responses received, was analysed and reported to 100%. The structure of the Questionnaire used is presented in the Table 1 and Table 2.

Table 1. Bio entrepreneur competencies characterisation - Technical skills

TECHNICAL SKILLS
Technological knowledge about manufacture of bio products and specific services
Technological knowledge about industrial life sciences sustainable applications
Intellectual Property Rights specific to bio economic sector
Multi disciplinary and cross disciplinary characteristics of life sciences
Innovation development based on R & D in life sciences sector
<b>Training model:</b> Training by transfer of knowledge in now-a-days systems: <ul style="list-style-type: none"> <li>• face to face learning,</li> <li>• e-learning,</li> <li>• blended learning</li> </ul> or other advanced ICT technologies

Source: [5,6,7,8].

Table 2. Bio entrepreneur competencies characterization - Management and Business knowledge

JUDGMENT AND APPROACH
Project financial set up and evaluation
Elaboration of a business plan, capacity of building organizations and staff teams and developing them by inter-company cooperation and cooperation between companies and academia.
Business intelligence
Methods to access to financing, long-term and venture capital financing, (big challenge for R & D, innovation, and science-based companies, where the inherent risk of innovation is high)
Assessment of the market of a product and payment mechanisms within the field of life sciences sustainable applications industry
Manufacturing and commercialization methods and sale agreements making
Economic and social models or regulatory issues developed by the authorities from a national and international perspective
<b>Training model</b> Training by transfer of knowledge in now-a-days systems: <ul style="list-style-type: none"> <li>• face to face learning,</li> <li>• e-learning,</li> <li>• blended learning</li> </ul> or other advanced ICT technologies

Source: [5,6,7,8].

**RESULTS AND DISCUSSIONS**

The survey analysis results are shown below.

**In terms of competencies characterization** of Management and Business Knowledge in the field of life sciences (Figure 1) required of an entrepreneur, we found the following:

- 98% of respondents need the abilities of manufacturing and commercialization;
- 100% of respondents consider useful to have a deeper understanding and knowledge to assess the market of the products and the mechanisms of payment;
- all the respondents have need of adequate knowledge regarding financial evaluation of the projects;
- 100 % of respondents consider important the technical, practical and ethical issues for using the management and analysis tools of their company;
- 100% of respondents consider important to have depth knowledge regarding understanding the economic sector and social models, regulatory issues and requirements of authorities from national and international perspective;
- all respondents are interested to know how to get the access to financing, especially long term and venture capital financing.

**In terms of Technical skills in the field of life sciences** (Figure 2) required of an entrepreneur, we found the following:

- 98% of respondents are people, who consider as necessary the proper knowledge and understanding of Intellectual Property Right,
- 89% of respondents consider having need of deeper knowledge about technologies which can generate products and services;
- 98% are interested to have deeper knowledge regarding industrial sustainable applications in the field of life sciences;
- 97% of respondents have needed a deeper knowledge of the multidisciplinary and cross-disciplinary characteristics in the life sciences. Based on this analysis, in which 97 % of respondents are interested to accumulate the knowledge regarding Technical skills and Business Management and taking into account the methods indicated into literature in order

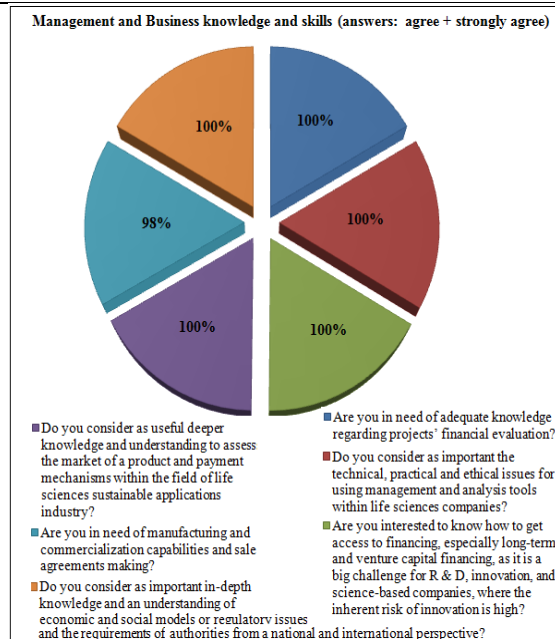

Fig.1. Management and Business Knowledge

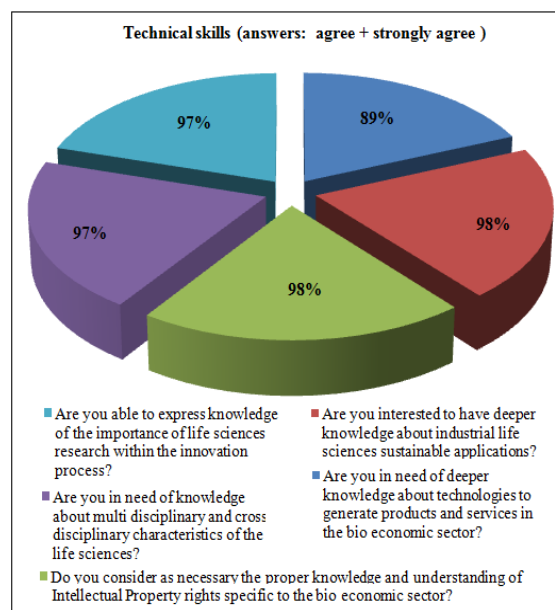

Fig.2. Technical skills

to transfer the knowledge in now-a-days systems, [5-8] the most adequate methods is the face to face, and the e-learning models, respectively a blended learning methodology. So, based on interests showed by target group (indicate by survey analysis), the structure of the Blended learning package to be built for BELA project will be the following:

- the training content “Enterprise business and intellectual property in life sciences” will be entirely adapted to e-learning;
- the training content “Sustainable Life sciences applications” will adapt as a blended

learning product, meaning: the module 1: Sustainable innovative small business or sustainable life sciences applications, and the conclusions: Vision for a better future will also be adapted to asynchronous e-learning. The other remaining modules will be delivered as face to face learning.

## CONCLUSIONS

Based on this analysis, in which 97 % of respondents are interested to accumulate the knowledge regarding Technical skills and the Business Management, the properly method to make this is the face to face and e-learning models, which corresponding to the blended learning methodology.

The structure of the Blended learning package to be built for BELA project will be the following: 1) the training content “Enterprise business and intellectual property in life sciences” will be entirely adapted to e-learning and the expertise of the foreign partners; 2) the training content “Sustainable Life sciences applications” will adapted as a blended learning product.

## ACKNOWLEDGEMENTS

The paper was supported by the project entitled: *Improved Curricula and Modern Learning System to Promote the New Directions of Business Enhancement in Life Sciences Applications*, Lifelong Learning Programme Leonardo da Vinci - Transfer of Innovation, project no: 2013-1-RO1- LEO05-28758. This publication reflects the views only of the author, and the Commission cannot be held responsible for any use which may be made of the information contained therein.

## REFERENCES

- [1]Allen, S.D., Graham, C.S., Ure, D. 2003, Blended learning environments: A review of the research literature, unpublished manuscript, Provo, UT, 2003.
- [2]Graham, C.R., Osguthorpe, R.T., 2002, Blended Learning Environments: Definitions and Directions. Quarterly Review of Distance Education 4 (3), 227-33.
- [3]Graham, C. R., Osguthorpe, R.T., Russell, T., 2003,

Blended Learning Environments: Definitions and Directions, Quarterly Review of Distance Education, Volume 4, Number 3.

[4]Leutner, F. G., Ahmetoglu, R., Akhtar, T.C., 2014, The relationship between the entrepreneurial personality the Big Five Personality traits, Personality and Individual Differences, 63, 58-63.

[5]Steed, C., 2011, Facilitating Live Online Learning, Publisher: Engaged Online Learning, 2011.

[6]www.forbes.com/2010/08/02/entrepreneur-personality.

[7]www.davincimethod.com/entrepreneur-test.

[8]www.potentielentrepreneur.ca/client/questionnaire.



## GROUNDWATER QUALITY IN A RURAL AREA FROM BUZĂU COUNTY, ROMANIA

Carmen ROBA<sup>1</sup>, Cristina ROȘU<sup>1</sup>, Ioana PIȘTEA<sup>1</sup>, Alexandru OZUNU<sup>1</sup>,  
Horia MITROFAN<sup>2</sup>

<sup>1</sup>Babeș-Bolyai University, Faculty of Environmental Science and Engineering, 400294 Cluj-Napoca, Romania, Phone: +40264307030, Fax: +40264307032, Emails: carmen.roba@ubbcluj.ro, cristina.rosu@ubbcluj.ro

<sup>2</sup>Sabba S. Ștefănescu Geodynamic Institute of Romanian Academy, R-020032 Bucharest, Romania, Phone: +40213172126, Fax: +40213172120, Email: horiamitrofan@yahoo.com

**Corresponding authors:** carmen.roba@ubbcluj.ro and cristina.rosu@ubbcluj.ro

### Abstract

*The underground water is the only source of drinking water in Buzău County. As a consequence the investigation of the underground water has a major importance. In the present study, a number of seven groundwater sources, located in Bisoca commune, NE of Buzău County, were selected in order to investigate the underground water quality. Several physico-chemical (temperature, pH, total dissolved solids, electrical conductivity, oxidation-reduction potential, salinity and turbidity) and chemical ( $Li^+$ ,  $Na^+$ ,  $K^+$ ,  $Mg^{2+}$ ,  $Ca^{2+}$ ,  $NH_4^+$ ,  $F^-$ ,  $Cl^-$ ,  $Br^-$ ,  $NO_2^-$ ,  $NO_3^-$ ,  $PO_4^{3-}$ ,  $SO_4^{2-}$ ,  $Cu$ ,  $Cd$ ,  $Cr$ ,  $Zn$ ,  $Fe$ ,  $Ni$  and  $Pb$ ) parameters were analyzed. The waters proved to have low salinity values (0.1- 0.8‰) and electrical conductivity (89.5 – 1993.0  $\mu S/cm$ ). The dissolved ions distribution is dominated by the presence of sodium (3.6 – 232.9 mg/l), calcium (6.8 – 365.43 mg/l), sulphates (10.9 – 1301.4 mg/l), bicarbonates (427 – 793 mg/l) and chloride (5.1 – 166.1 mg/l). In the case of iron and lead there were registered exceeding's of maximum permissible limits for drinking water.*

**Key words:** Buzău County, groundwater, water quality parameters

### INTRODUCTION

Accessibility and availability of fresh clean water represents a key factor for a sustainable development, being an essential element in the human health, food production and poverty reduction [10]. In many rural areas from Romania, the underground water represents the primary source of drinking water, which is usually considered a safe source of drinking water.

In Buzău County, the underground water is the only source of drinking water in the area. Buzău Land is an isolated, mostly mountainous area, inhabited by approximately 40,000 people. It's located at the bending of the Carpathians, in the proximity of the Vrancea seismic zone, in a geodynamical active context that gives rise to slope failures, mud volcanoes, natural gas seepage and mineralized water springs [3], [5], [6],[7], [8]. The main goals of the present study were: to assess the water quality of seven ground water sources located in a rural area from Buzău

County (NE of Romania) and to find out the potential health risks for local people by using these sources as drinking water sources.

### MATERIALS AND METHODS

The investigated water sources are located in Bisoca commune in the north of Buzău County, Romania. Bisoca commune is composed of eight villages: Băltăgari, Bisoca, Lacurile, Lopătăreasa, Pleși, Recea, Sările and Șindrila. The commune area it has a surface of 73 km<sup>2</sup> and a population of 2,962 inhabitants. The investigated water sources consisted of five captured springs (S1-Bisoca village, S2-Sările village, S3-Recea village, S4-Lacurile village and S5-Băltăgari village), one well (W6) from Bisoca village and the public network from the Bisoca commune (PN7) (Fig. 1). The investigated ground waters are used for drinking, cooking, bathing, agricultural and therapeutically (sample S5 which is a sulphurous spring) purposes. The investigated water sources are located in the

future Geopark of Buzău Land. The water samples were collected during October 2014.

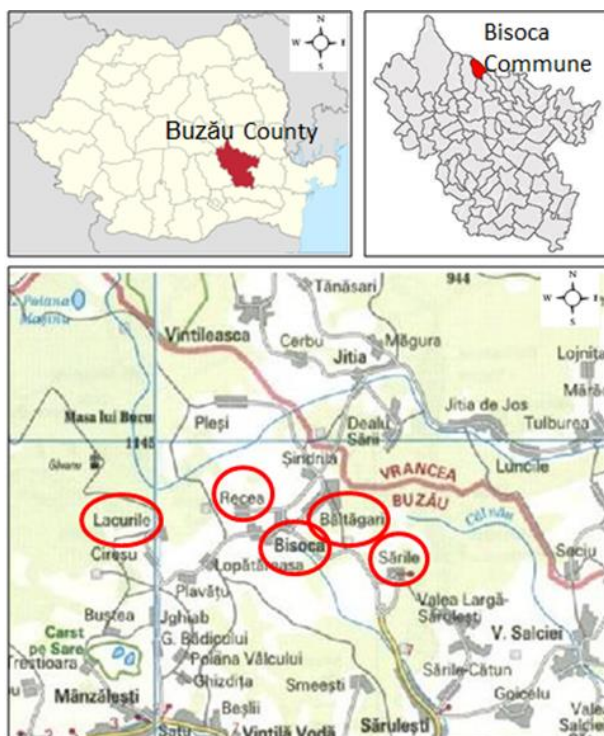

Fig. 1. Location of the investigated area

Source: Own determination.

The unstable physico-chemical parameters (temperature, pH, redox potential – ORP, electrical conductivity – EC, total dissolved solids – TDS, salinity, dissolved oxygen – DO and turbidity) were measured *in situ* using a portable multiparameter (WTW inolab 350i) and a portable turbidimeter (WTW pHotoFlex Turb). The water samples used for major dissolved ions analysis were collected in polyethylene bottles; the water samples were filtered *in situ* using 0.45 µm syringe filters. The water samples used for heavy metals analysis were acidified to a pH ≈ 2 (with HNO<sub>3</sub> 65%). The samples were then shipped to the laboratory, stored at dark and 4°C, and analyzed within 48 hours from sampling. The major dissolved ions (Na<sup>+</sup>, K<sup>+</sup>, Mg<sup>2+</sup>, Ca<sup>2+</sup>, F<sup>-</sup>, Cl<sup>-</sup>, Br<sup>-</sup>, NO<sub>2</sub><sup>-</sup>, NO<sub>3</sub><sup>-</sup>, PO<sub>4</sub><sup>3-</sup> and SO<sub>4</sub><sup>2-</sup>) were analyzed by ion chromatography (IC1500 Dionex), while CO<sub>3</sub><sup>2-</sup> and HCO<sub>3</sub><sup>-</sup> were determined titrimetrically. The heavy metals (Fe, Zn, Cu, Cd, Cr, Pb and Ni) were analyzed by using the flame atomic absorption spectrometry (FAAS) and graphite furnace (GAAS), depending on the concentration. For

the heavy metals analysis, an AAS system ZeeNIT 700, Analytik Jena was used. All the analyses were performed in the Environmental Laboratory from the Faculty of Environmental Science and Engineering (Babeş Bolyai University from Cluj-Napoca). The analyzed data were compared with the standard values recommended by the Romanian and international legislation.

## RESULTS AND DISCUSSIONS

The results of both *in situ* and instrumental analyses are summarized in Table 1.

Table 1. Synthesis of the physico-chemical and chemical parameters of the analyzed water samples

Parameter	Min.	Maxim	Average	Maximum Permissible Limit <sup>1</sup>	
T(°C)	9	15	12	-	
pH	5.6	7.5	6.6	6.5 – 9.5	
ORP (mV)	-	49.4	58.2	-3.13	-
EC (µS/cm)	89.5	1993.0	752.4	2500	
TDS (mg/l)	57.1	1278.0	478.1	500 <sup>2</sup>	
Salinity (‰)	ND <sup>3</sup>	0.8	0.2	-	
DO (mg/l)	2.3	5.4	3.8	>5	
Turbidity (NTU)	ND	27.6	7.16	≤5	
Li <sup>+</sup> (mg/l)	ND	0.3	0.2	-	
Na <sup>+</sup> (mg/l)	8.6	232.9	144.9	200	
K <sup>+</sup> (mg/l)	2.6	19.3	8.3	10 <sup>2</sup>	
Mg <sup>2+</sup> (mg/l)	1.6	46.5	15.3	50 <sup>2</sup>	
Ca <sup>2+</sup> (mg/l)	6.8	365.4	99.8	200 <sup>2</sup>	
NH <sub>4</sub> <sup>+</sup> (mg/l)	ND	0.4	0.3	0.5	
F <sup>-</sup> (mg/l)	ND	2.2	0.9	1.2	
Cl <sup>-</sup> (mg/l)	5.1	166.1	62.2	250	
Br <sup>-</sup> (mg/l)	ND	3.9	-	-	
NO <sub>2</sub> <sup>-</sup> (mg/l)	ND	4.1	-	0.5	
NO <sub>3</sub> <sup>-</sup> (mg/l)	1.9	12.9	8.1	50	
SO <sub>4</sub> <sup>2-</sup> (mg/l)	10.9	1301.4	235.7	250	
HCO <sub>3</sub> <sup>-</sup> (mg/l)	427	793	610.9	-	
Fe (µg/l)	76.2	405.4	172.9	200	
Zn (µg/l)	9.9	1240.9	307.3	5000	
Cu (µg/l)	18.5	83.6	42.8	100	
Cd (µg/l)	0.01	0.31	0.14	5	
Cr (µg/l)	4.5	31.8	12.6	50	
Pb (µg/l)	27.4	571.9	127.4	10	

<sup>1</sup>According to Romanian legislation for drinking water (Law 458 from 08.07.2002); <sup>2</sup>According to BC Health Act Safe Drinking Water Regulation–Canada [1] and World Health Organization [11], [12]; <sup>3</sup>ND = Not Detected  
Source: Own calculation.

As it can be seen in Table 1 and Fig. 2 the analyzed water samples were slightly acidic to neutral, having the pH between 5.6 and 7.5. In the water samples collected from two springs

(S3, S4) and from the well (W6) the pH level was lower than the permissible limit (6.5) set by the Romanian drinking water law (458/2002).

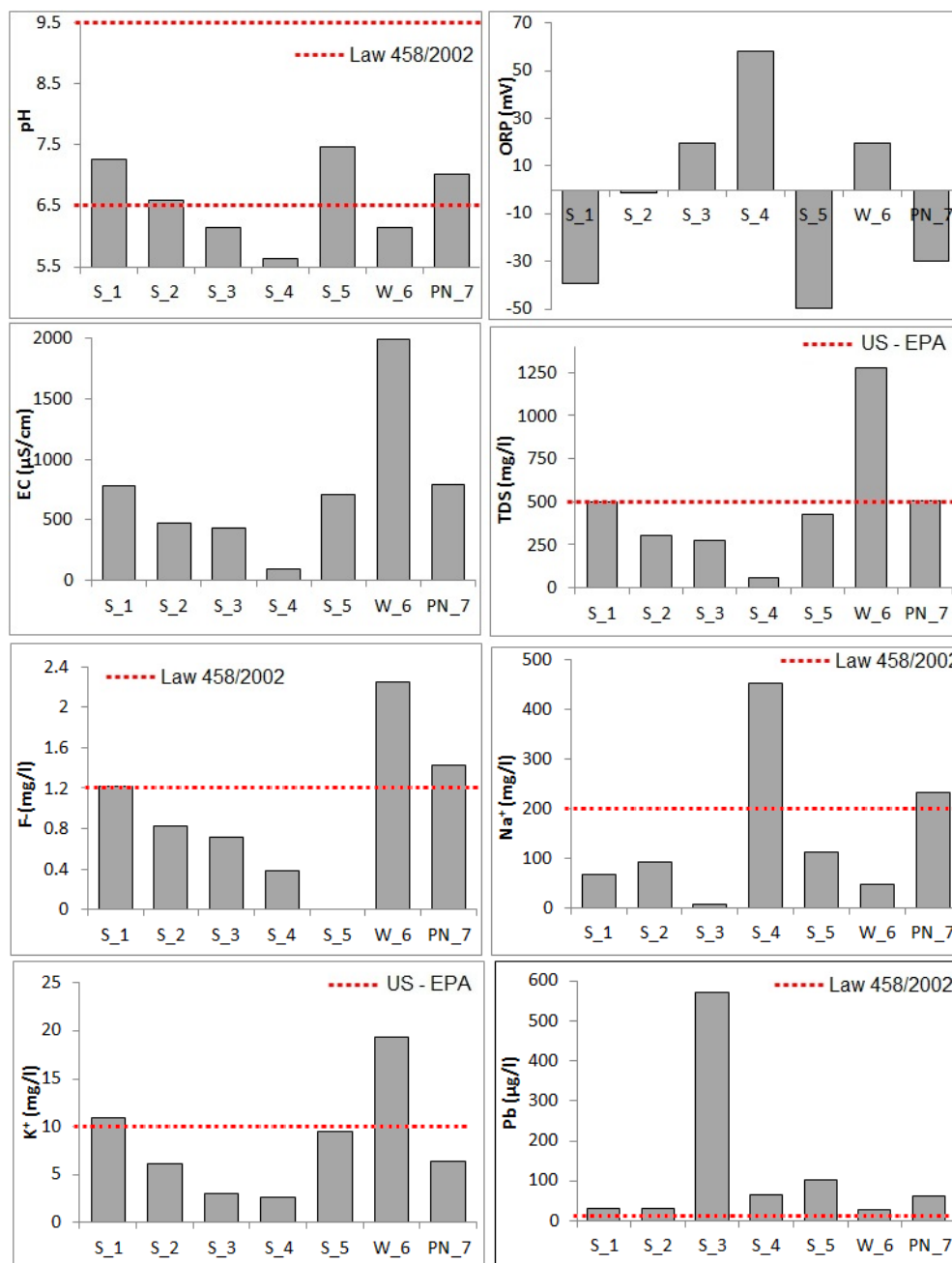

Fig. 2. The main physico-chemical and chemical parameters of the analyzed water samples (S1 – captured spring from Bisoca village; S2 – captured spring from Sărule village; S3– captured spring from Recea village; S4 – captured spring from Lacurile village; S5 – captured sulphurous spring from Băltăgari village; W6 – well from Bisoca village and PN7 – public network from Bisoca commune)  
Source: Own calculation.

The analyzed water samples had a redox potential between -49.5 and 58.2 mV. The highly negative value was recorded in samples taken from the sulphurous spring (S5), while the highly positive value was

recorded in the water sampled from the spring S4 (Fig. 2). Such high values of ORP, ensures chemical stability for some metal salts and hydroxides (Fe, Mn, etc.) and chemical instability of organic substances, increasing

their decomposition. A low ORP may indicate the presence of anaerobic redox potential and reducing conditions in the aquifer, while a positive redox potential indicate the presence oxidizing environments. All the analyzed water samples had the ORP between -100 and 100 mV, values recommended by the WHO (World Health Organization) and US-EPA (United States – Environmental Protection Agency) for drinking water [9], [11], [12].

With the exception of sample collected from well (W6), the analyzed waters had a relatively low electrical conductivity, between 89.5 and 790  $\mu\text{S}/\text{cm}$ , being lower than the limit (2500  $\mu\text{S}/\text{cm}$ ) imposed by national legislation. The water sampled from well from Bisoca village (W6) had a higher EC (1993  $\mu\text{S}/\text{cm}$ ), being however lower than the maximum limit imposed by legislation.

With the exception of sample W6, the analyzed waters proved to be oligomineral waters, having the total dissolved solids contend below 1 g/l [4]. Sample W5 can be classified as mineral water mineral with an average mineralization, having the TDS between 1 and 15 g/l. Because of the high TDS contents, it is not recommended to use the water from W6 sampling point for agriculture purposes. A TDS values between 1000 - 2000 mg/l present high risk for agricultural use [13], reducing the soil permeability and aerating.

As in the case of EC and TDS, with the exception of sample W6 (0.8‰), the analyzed waters proved to have a low salinity (0.1‰ for S1, S5 and PN7), being within the maximum limit (0.2‰) imposed by US-EPA. The high values of EC, TDS and salinity recorded for the well W6 from Bisoca village, reflect the high content of dissolved salts in water samples, which are correlated with the geological characteristics of the aquifer. High values of EC and TDS, reflect the presence of high concentrations of salt ( $\text{HCO}_3^-$ ,  $\text{SO}_4^{2-}$ ,  $\text{Cl}^-$ ) of calcium, magnesium, sodium and silica in the water samples. In addition an increased level of salts increases water turbidity and hardness, decreases dissolved oxygen level, causing different problems in the water treatment process.

With the exception of sample S5 (5.4 mg/l),

the investigated waters, had a low level of dissolved oxygen (2.3-4.6 mg/l), which is below the minimum limit of 5 mg/l imposed by national legislation (Law 458/2002).

With one exception (S4), the investigated water sources had a low turbidity, being lower than 1 NTU, which is the maximum permissible limit imposed by national legislation.

In the spring S4, a considerably higher level was registered (27.6 NTU), which can be associated with the presence of a large number of micro-organisms, such as viruses, parasites and certain bacteria.

The continuous consumption of drinking water from these sources may be associated with symptoms such as nausea, cramps, diarrhea and headaches.

As it is shown in the Piper Diagram (Fig. 3) the major dissolved ions distribution is dominated by the presence of sodium (3.6 – 232.9 mg/l), calcium (6.8 – 365.43 mg/l), sulphates (10.9 – 1301.4 mg/l), bicarbonates (427 – 793 mg/l) and chloride (5.1 – 166.1 mg/l).

The investigated water sources proved to have a relatively low level of calcium and magnesium. With the exception of sample W6, the both calcium (6.8 – 124.53 mg/l) and magnesium (1.6 – 19.38 mg/l) levels were within the maximum limits (200 mg/l and 50 mg/l) recommended by the World Health Organization. The investigated well from Bisoca (W6) proved to have higher calcium content (365.4 mg/l). Calcium and magnesium are among the macroelements essential for life. It is known the importance of Ca/Mg ratio in water. An optimal value for this ratio is 2:1, offering greater protection against cardiovascular disease. In the present study, the values of Ca/Mg ratio ranged between 3.1 and 10.3. In addition, a high content of calcium and magnesium increase the water hardness.

The water samples collected from spring S4 and from the public network (PN7) had considerably high sodium level, exceeding the maximum permissible limit (200 mg/l) imposed by national legislation (Fig. 2). The other samples had a low level of sodium, between 8.6 and 112.1 mg/l.

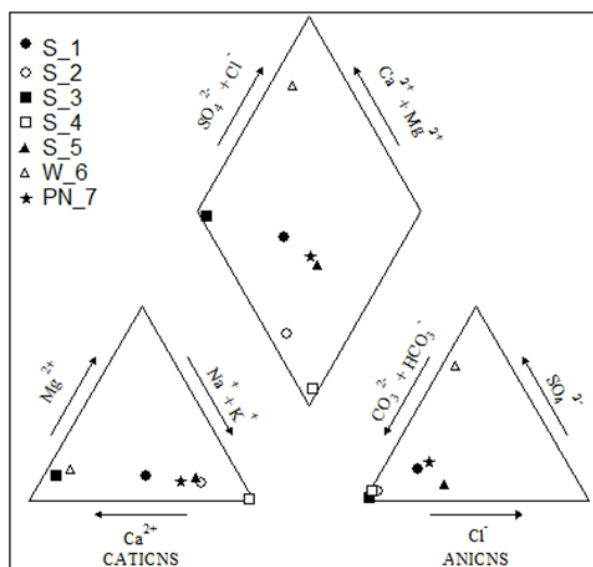

Fig. 3. Piper diagram for the investigated water sources  
Source: Own determination.

The spring S1 and the well W6 had the higher potassium level, exceeding 10 mg/l, value recommended by US-EPA and WHO for human health protection (Fig. 2). Recent studies [2] showed that high levels of sodium and potassium in the diet or drinking water can be associated with increased incidence of hypertension. The optimal Na/K ratio is 3:1. In the analyzed water samples, the Na/K ratio was relatively high, ranging between 2.5 and 174.9.

Lithium (0.03-0.33 mg/l) and ammonium (0.2 mg/l in S3 and 0.4 mg/l in PN7) had the lower levels among the analyzed cations, being within the maximum permissible limit for drinking water.

Laboratory analysis showed that three of the investigated water sources (S1, W6 and PN7) had a relatively high content of fluoride, this parameter exceeding the maximum permissible limit (1.2 mg/l) (Fig. 2), which coincides with the value recommended for dental caries prevention. This parameter was not detected in the sulphurous spring (S5), probably due to the high dilutions of samples prior analysis.

The chloride level was relatively low (5.1 – 166.1 mg/l), being lower than the maximum permissible limit (250 mg/l) in all the analyzed samples. Bromine and nitrites were detected only in sample S2 (3.9 mg/l and 4.1 mg/l). In case of nitrite, the maximum

permissible limit for drinking water (0.5 mg/l) was considerably exceeded. The continuous usage of this source as drinking water represents a real threat for local people health, because nitrites are classified as toxic to human body. The high content of nitrites indicates the presence of a recent pollution source.

Nitrate was detected in all the investigated water, the level of this chemical parameter ranged between 1.9 and 12.9 mg/l, being considerably lower than the maximum permissible limit (50 mg/l) imposed by national legislation.

With the exception of well from Bisoca village (W6), the analyzed water samples had a low level of sulphates (10.9 – 119.7 mg/l), being lower than the maximum permissible limit of 250 mg/l. Because of the high level of sulphates (1301.4 mg/l), the water from sampling point W6 can be used as sulphated waters (>1 g/l sulphates). Sulphated waters can be used for internal treatment in digestive diseases (intestinal, hepatobiliary), but only in strict doses and under the supervision of doctor.

Carbonate ion was not detected in the investigated waters, while the bicarbonate ion was detected in all analyzed samples, ranging between 427 and 793 mg/l. The highest values were recorded for well W6 which indicate that these waters are alkaline water, sodium bicarbonate being the dominant in these waters.

Distribution of heavy metals in water samples investigated is dominated by the presence of zinc (9.9 -1240.9 µg/l), iron (76.2 – 405.4 µg/l), copper (18.5 – 83.6 µg/l) and lead (27.4 – 571.9 µg/l). Cadmium (0.01 – 0.31 µg/l) and chromium (4.5- 31.8 µg/l) were present in lower concentrations (Table 1). The investigated water sources proved to have low levels of Zn, Cu, Cd and Cr, all this chemical parameters were within the maximum permissible limits imposed by national legislation for drinking water. Nickel was not detected in any of the analyzed samples. With the exception of well W6 from Bicoca, where the Fe level was 405.4 µg/l, the other investigated drinking water sources had a lower Fe level (76.2 – 169.0 µg/l), being

within the maximum permissible limit of 200 µg/l.

The laboratory analysis proved the presence of high level of lead (27.4 – 571.9 µg/l). This element exceeded the maximum permissible limit (10 µg/l) in all the analyzed water samples (Fig. 2). The highest level was recorded in the spring S3 from Recea village. Lead is a toxic element, classified as "carcinogenic to humans". As such, the constant usage for a long time of these water sources as drinking waters can lead to severe health effects for residents. Target organs that may be affected are the kidneys, liver, spleen and lungs. These water sources must be carefully monitored in order to investigate the existence of an accidental pollution source, otherwise the water consumption from these sources should be stopped or significantly restricted.

## CONCLUSIONS

The results of the present study showed that in some of the investigated groundwater sources, some of the analyzed physico-chemical and chemical parameters exceeded the maximum permissible limit imposed by national and international legislation. The exceeding's were recorded in the case of: pH, TDS, DO, turbidity, Na<sup>+</sup>, K<sup>+</sup>, Ca<sup>2+</sup>, F<sup>-</sup>, NO<sub>2</sub><sup>-</sup>, SO<sub>4</sub><sup>2-</sup>, Fe and Pb. The continuous consumption of drinking water from these sources may be associated with symptoms such as nausea, cramps, diarrhea and headaches.

Because the high level of NO<sub>2</sub><sup>-</sup> (in sample S2) and Pb (in sample S3), the continuous usage of this springs as drinking water sources represents a real threat for local people health, because these elements are classified as toxic to human body. These water sources must be carefully monitored in order to investigate the existence of an accidental pollution source, otherwise the water consumption from these sources should be stopped or significantly restricted.

## ACKNOWLEDGEMENTS

The research leading to these results has received funding from EEA Financial

Mechanism 2009 - 2014 under the project contract no 22 SEE/30.06.2014 GEOSUST/EEA-JRP-RO-NO-2013-1-0135, entitled „Applied research for sustainable development and economic growth following the principle of geoconservation: supporting the Buzau Land UNESCO Geopark initiative”.

## REFERENCES

- [1]BC Health Act Safe Drinking Water Regulation BC Reg 230/92, & Sch 120, 2001. Task force of the Canadian Council or Resource and Environment Ministers Guidelines for Canadian Drinking Water Quality.
- [2]Diaconu, D., Voroniuc, O., Nastase, V., Navrotescu, T., Gheorghes, M., Ciobanu, O., 2005, Levels of magnesium and other inorganic compounds in water of wells. Journal of Hygiene and Public Health, Journal of Hygiene and Public Health, Vol. 55(5): 20-27
- [3]Feru, A., 2012, Guide the natural mineral waters, Novis Press, Bucharest
- [4]Munteanu, C., 2013, Therapeutic mineral waters, Balneara Press, Bucharest
- [5]Pitulescu, G., Repanovici, G., 1953, Analysis of Romanian mineral waters, Technical and economic studies, Vol. B (37): 3-83
- [6]Pricăjan, A., 1985, Therapeutic mineral substances of Romania, Scientific and Encyclopedic Publishing House, Bucharest
- [7]Saabner-Tuduri, Al., 1906, Mineral waters and climatic resorts in Romania, 2<sup>nd</sup> edition, Gutenberg Press, Bucharest
- [8]Ştefănescu, C., 1967, Resorts and spas from Romania, Meridians Press, Bucharest
- [9]US-EPA, 1991, National primary drinking water regulation, radionuclides (proposed rules), vol 56. US Environmental Protection Agency, Federal Register, p 138
- [10]Wang, S., 2013, Groundwater quality and its suitability for drinking and agricultural use in the Yanqi Basin of Xinjiang Province, Northwest China, Environmental Monitoring Assessment, Vol. 185(9): 7469-7484
- [11]WHO (World Health Organization), 1984, Guideline for drinking water quality, Vol. 2, Health Criteria and Other Supporting Information. World Health Organization, Geneva
- [12]WHO (World Health Organization), 2008, Guidelines for Drinking Water Quality. Third edition incorporating the first and second addenda, Vol.1, Recommendation, NCW classifications WA675
- [13]Wilcox, L.,V., 1955, Classification and use of irrigation waters, Publisher: U.S. Department of Agriculture, Washington, D.C



## THE CONTROLLING USING TECHNICAL INSTRUCTIONS OF OPERATIONAL

**Titin Fittono RULIANA**

University of August 17<sup>th</sup>, 1945 Samarinda, Jl. Ir. H. Juanda No.80 Samarinda City, postcode no.1052, Phone: (0541) 761113, East Kalimantan, Indonesia. Mobile: 081346272281, Email: titin.ruliana15@gmail.com

**Corresponding author:** titin.ruliana15@gmail.com

### **Abstract**

*LKM Bakti Mandiri is the community agencies that led by collective of collegial, autonomous, independent, initiated and formed directly by community members in Urban Village Handil Bakti, Province of East Kalimantan – Indonesia. LKM aims to community empowerment, under the auspices of PNPM Mandiri. This study compares implementation of the controlling by LKM Bakti Mandiri with principles and procedures set forth in Technical Instructions of Operational for PNPM ). Controlling consist of Monitoring and Supervision; Evaluation; Reporting; and Management of Complaints and Problem. Controlling is done on LKM Bakti Mandiri includes Tridaya activities namely Activities of Social, Environmental Activities and Economic Activities. Source of data is obtained from interviews, and observations on LKM Bakti Mandiri. The results showed that implementation of the Tridaya LKM Bakti Mandiri not yet accordance with Technical Instructions of Operational for PNPM. Some of the weaknesses that need improvement as follows: Analysis of loan; Examination and eligibility loan of prospective borrower; Supervision and controlling to the business analysis of LKM members; The absence of a loan rejected; Clarification of beneficiaries educational activities; Examination of the realization of the activities and costs; Preparing reports based on the summary evidence of transactions. The Conclusion of study that Tridaya LKM Bakti Mandiri activities not yet accordance with Technical Instructions of Operational for PNPM. Many procedures of activities of the technical Instructions are not fulfilled will affect the achievement of goals and objectives in LKM especially and PNPM generally.*

**Key words:** controlling, technical instructions of operational

### **INTRODUCTION**

Economy and welfare of the community is done through an increase in development in the all aspects of life. Efforts to improve this construction, to improve the effectiveness of the reduction of social inequalities (poverty) and job creation through increased revenue. The Indonesian government proclaimed various programs in an effort to empower people one of which is through the National Program for Community Empowerment. It is called PNPM-Mandiri

The government launched the National Program for Community Empowerment (It is called as PNPM-Mandiri) in 2007. [3] The program is formulating participatory development process involving elements of society. This is a raise awareness of critical and independence of the community, especially the poor. The National Program for Community Empowerment (PNPM-Mandiri)

expanded starting in 2008 with the involvement of the Program of Social Infrastructure Development Regional Economics to integrate the centers of economic growth in the surrounding area. The National Program for Community Empowerment (PNPM) reinforced with various community development programs implemented by various ministries or sectors and local government. The implementation of the National Program for Community Empowerment (PNPM-Mandiri) in 2008 more prioritized on the poor villages.

Community Institution “LKM Bakti Mandiri” was formed in 2010, The Community Institution is do Tridaya activities namely social, environmental, and economic.

Tridaya activities constitute universal principles of sustainable development which is the principle of balanced development, which in according the National Operational

Programme for Community Empowerment (PNPM) translated as social activities, economic and environmental. [4]

“LKM Bakti Mandiri” is the Community Institution that led by collective of collegial, autonomous, independent, initiated and formed directly by community members in Urban Village Handil Bakti, Province of East Kalimantan – Indonesia. LKM aims to community empowerment, under the auspices of PNPM Mandiri. Activities of Community Institution "LKM Bakti Mandiri" obtain funding source comes from the State Budget, Local Budget, community, and Participation Business. [1]

Implementation activities Community Institution "LKM Bakti Mandiri" in regulated in the Technical Instructions of Operational, National Program for Community Empowerment (PNPM). It is listed in the Circular Letter of the Minister of the Interior, represented by the Director General of Community No. 414.2/3717/PMD in 2008 [6] that "To improve the effectiveness of the performance, the Technical Instructions of Operational in order to become a reference in the technical implementation of the operational of program that contains the program policies, the role of the actors, the activities, and control of implementation".

The Technical Instructions of Operational is expected as controlling of activities Tridaya in the decision making process and to realize the vision and mission of the institution.

Implementation activities Tridaya on the Community Institution LKM Bakti Mandiri (environmental activities, social, and economic) note there are still some nonconformities with the Technical Instructions of Operational that apply, causing irregularities such as bad credit, mismatches of budget against its realization, data manipulation and so on.

This is due not implemented the principles and procedures set forth in the Technical Instructions of Operational of PNPM, among other things, not made weekly reports, final reports based only on a summary of the fund expenditure of activities in the absence of a detailed study of the realization in the field, non-compliance with the provisions of the

revolving fund management mechanism.

Formulation of the problem in this paper is as follows: (1) Is the controlling of Tridaya activities Community Institution "LKM Bakti Mandiri" in accordance with the Technical Instructions of Operational of the National Operational Programme for Community Empowerment (PNPM) applicable? (2) Are the causes of nonconformities application of the Technical Instructions of Operational of the National Operational Programme for Community Empowerment (PNPM) on Tridaya activities of Community Institution "LKM Bakti Mandiri”

## MATERIALS AND METHODS

This study compares the application of controls by Community Institution "LKM Bakti Mandiri" with the principles and procedures set forth in the Technical Instructions of Operational of the National Operational Programme for Community Empowerment (PNPM). Based on the Circular Letter of the Minister of the Interior, represented by the Director General of Community No. 414.2/3717/PMD in 2008 [1], Chapter V (fifth) of Controlling. Controlling consists of: Monitoring and Supervision; Evaluation; Reporting; and Complaints Handling and Problem.

The Controlling is done at Community Institution LKM Bakti Mandiri include Tridaya activities [3], namely Social Activity, Environmental Activity and Economic Activity. Source of data obtained from interviews, and observations on community institution "LKM Bakti Mandiri". The study was conducted in the period January to June 2014.

Measurement of the controlling parameters [5], as follows:

$$\text{Percentage} = \frac{\text{Good Answer}}{\text{Sum of All Answer}} \times 100\%$$

The measurement results of controlling are grouped [2] as follows:

- 76 % - 100 % = a good
- 56 % - 75 % = is quite good
- 40 % - 55 % = less well
- under 40 % = is not good



**RESULTS AND DISCUSSIONS**

The study using the comparative method, aiming to: (1) Compares conformance controlling on the Technical Instructions of Operational of the National Operational Programme for Community Empowerment (PNPM) applicable on Tridaya activities of Community Institution "LKM Bakti Mandiri". (2) The cause of the mismatches controlling on the Technical Instructions of Operational of the National Operational Programme for Community Empowerment (PNPM) applicable on Tridaya activities of Community Institution "LKM Bakti Mandiri".

Table 1. Results of Measurement Controlling

Activities	Category Percentage				Total
	A good	is quite good	less well	is not good	
Economy	20	1	2	1	24
Social	15	5	1	-	21
Environmental	14	7	2	-	23
Total	49	13	5	1	68

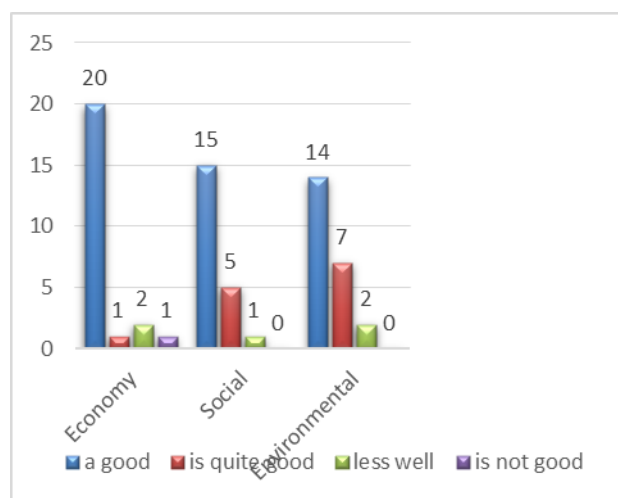

Fig. 1. The Measurement Results of Controlling

Based on the results of the comparison between the activities implementation of Tridaya at the community institutions "MFI Bakti Mandiri" against the Technical Instructions of Operational of the National Operational Programme for Community Empowerment (PNPM), obtained the answers by the criteria of "Good" as many as 49 (forty nine) at 72.06% of all the answers as many of 68 (sixty eight). This shows that the community institution "LKM Bakti Mandiri"

in the implementation of activities not correspond with against the Technical Instructions of Operational of the National Operational Programme for Community Empowerment (PNPM), This shows that the community institution "LKM Bakti Mandiri" in the implementation of activities not correspond with against the Technical Instructions of Operational of the National Operational Programme for Community Empowerment (PNPM),

This shows that there are some weaknesses in the activities Tridaya are Social Activity, Environmental Activity and Economic Activity. Weaknesses are:

**Economic Activities:**

(1) It may cause bad debts because there are flaws in the analysis of the loan is based on 5C (character, condition, capacity, capital and collateral) the following: *Character*: do not do information search about the disposition and character of prospective borrowers; *Condition*: see the condition of the business of the prospective borrower about the possible continuation of the business; *Capacity*: see the ability of business to earn profits; *Capital*: look at the ability of capital, debt guaranteed; *Collateral*: assessing items that can be used as collateral for loans; (2) There is a weakness in pemberian credit worthiness checks as PNPM target and as a potential borrower; (3) not done coaching by officers of Activity Management Unit to borrowers (visits to the place of business, or home of borrowers) so that allowing uncontrolled of business continuity and existence of debtor. This is can lead to bad credit.

**Social Activities:**

(1) Low controlling against business analysis of members enables deviation of data by the borrower, and can cause bad credit; (2) The absence of a clear measurement against level of understanding of the Social Management Unit as the executor of the principles of management of the activities undertaken; (3) In the community institutions "LKM Bakti Mandiri" it's found no loans were rejected, meaning that all loans declared eligible. This indicates the absence of selection activities offer; (4) It's not done clarification to the field against the beneficiaries of educational

activities, so lets not achieve its goals for social activities, both in terms of the criteria of the recipient and in terms of sustainability of activities.

### **Environmental activities**

(1) Do not be announced to the public about the need for labor, working days, and wages. It is suspected among the parties who filed The Budget Plan utilize advantage of a given work; (2) Low of supervision of procurement activities of materials and tools valued at less than 15 million dollars; (3) photos shown do not meet the criteria of the documentation phase, namely photo showing women's participation in infrastructure activities (although in the budget realization report dikatahui the participation of women in the implementation); (4) Examination of the realization of the activities and costs (Budget Plan) is not fully made in accordance with the actual conditions, and shows the final target of the execution. Because the preparation of reports based only on summary evidences of transactions that occur.

Based on the findings - the above findings it can be concluded that social institutions "LKM Bakti Mandiri", its activities not yet accordance with the Technical Instructions of Operational, National Program for Community Empowerment (PNPM). Many of procedures of activities on the Technical Instructions of Operational that are not met certainly will affect the achievement of goals and objectives community institutions "LKM Bakti Mandiri" and National Program for Community Empowerment (PNPM) generally.

### **CONCLUSIONS**

Based the study results revealed that the implementation of activities Tridaya on the Community Institution "LKM Bakti Mandiri" is still not going well, means community institutions of "LKM Bakti Mandiri" perform activities is not in accordance with the Technical Instructions of Operational, National Program for Community Empowerment (It's call as PNPM). This is

evidenced by the value percentage yield of 72.06% of the controlling measurements. The cause of nonconformities (weaknesses) that require improvement such as the following:

(1) Analysis of loans based on the 5C (character, condition, capacity, capital and collateral), which allows the emergence of bad debts; (2) Examination of the feasibility of loans and prospective borrower is not in accordance with the Technical Instructions; (3) Low of supervision, controlling and evaluation, analysis of business members and the presence of the borrower; (4) Do not do clarification to the field against the beneficiaries of educational activities; (5) Inspection of Actual Activity and Budget of Cost made not in accordance with the conditions and the target of implementation. Because preparation of reports based only on summary of evidences of any transactions that occur.

### **REFERENCES**

- [1] Agency for Self-Reliance Development/ Communities Institutions. The National Program for Community Empowerment for Urban. 2009, Published by the Directorate Jenderat "Cipta Karya" - Ministry Public Works, page 2.
- [2] Arikunto, S., 2006, Research Procedure A Practical Approach, Published by Rineka Cipta, page 246.
- [3] General Guidelines of the National Program for Community Empowerment for Urban., 2007, Indonesian Foreign Ministry, page 1.
- [4] Guidelines for the Implementation of PNPM Urban Tridaya, 2010, Indonesian Foreign Ministry, page 10.
- [5] Sudjana. 2001, Statistical Methods, Published by Bandung: Tarsito, page 129.
- [6] The Circular Letter of the Minister of the Interior, 2008, represented by the Director General of Community No. 414.2/3717/PMD in 2008.

## THE LOCAL ORIGINAL REVENUE ANALYSIS OF EAST KALIMANTAN PROVINCE, INDONESIAN

**Titin RULIANA**

University of August 17<sup>th</sup>, 1945 Samarinda, Jl. Ir. H.Juanda No.80 Samarinda City, postcode no.1052, Phone: (0541) 761113, East Kalimantan, Indonesia, Mobile: 081346272281, Email: titin.ruliana15@gmail.com

**Corresponding author:** titin.ruliana15@gmail.com

### **Abstract**

*Target Acceptance Local Original Revenue, East Kalimantan Province (Revenue Office of East Kalimantan, 2014) showed an increase in revenue realization during 2009 through 2013 was 112.83%. It requires effort and work to increase the potential revenue from Local Original Revenue. This study to measure the effectiveness and contribution acceptance of Local Original revenue in East Kalimantan in 2009 until 2013. Measurements using effectiveness ratio and contribution ratio performed on the elements of Local Original Revenue (Act No. 32 of 2004) consists of local taxes, local retribution, profit company owned by local, regional wealth management results, and other Local Original Revenue receipt. The results showed that realization of acceptance Local Original Revenue, East Kalimantan Province was appropriate even exceed the targets set by the achievement of 113.69% (Effectiveness Ratio) to receipt sourced from local taxes, local retribution, results wealth of management that separated areas, and other legitimate local revenues during the year 2009 until 2013. Local Original Revenue realization highly effective through other revenues legitimate local revenues (118.18%). The reception area is dominated / greatest sourced from local taxes contributed 78.56% (ratio Contributions) of the overall receipt the Local Original Revenue. The results of the study concluded that the receipt of Local Original Revenue in accordance with the criteria of effectiveness ratio. It is ratio very efficient. Local tax contribution was excellent of 78.56% (ratio Contributions) to the total revenue receipt of East Kalimantan province during 2009 until 2013.*

**Key words:** contribution, effectiveness, the Local Original Revenue

### **INTRODUCTION**

Government and regional development financing comes from revenues, its from the public or from the government itself. Regional Revenue Structure of East Kalimantan province consists of The Local Original Revenue, Fund Balance, and Everything Else Regional Income Legitimate. [4]

Local taxes revenue, retribution, profit company owned by local, regional wealth management results, and other the local original revenue is a source of revenue in The Local Original Revenue (it is called PAD). [4] Explanation sources of revenue The Local Original Revenue, as follows:

- (1) The results of regional taxes is Local charges according to regulations set by the region for the financing of the household as a public legal entity;
- (2) Results of local retribution namely charges have been legally be local charges as payment for the use or obtain services or because

obtaining employment services, businesses or local government property in question; (3) The results of the company-owned local and regional wealth management outcomes separated. The results of a local company owned by the local revenue of the company's net profit in the form of local and regional development fund part of the state budget paid to the local treasury; (4) Earning of Other areas legitimate is is earnings are not included in the types regional taxes, retribution area, revenue offices. Besides Local Original Revenue, the reception area is still dominated by Fund Balance consists of the tax revenue sharing, non-tax sharing, general allocation fund, a special allocation fund, and fund local incentives. On the other hand, to support acceptance for the government and regional development through tax sharing of center / Among them, through the Personal Income Tax in the State, Article 21 of the Income Tax, Value Added Tax and others [4]

Objects Local Taxes are an expansion of the tax object stipulated in Law No. 18 of 1997 and Act No. 34 of 2000 namely Motor Vehicle Tax, Customs of Vehicle, Motor Vehicle Fuel Tax, Tax Intake and Utilization of Ground Water and Surface Water and Cigarette Tax. [5]

Expansion of Regional Tax object is to improve the reception local, improve the structure of local financing, reduce the role of sources of good financing from the central government or borrowing from abroad. To further enhance the independence of in activities of financing in the area, then the effort to increase revenue from taxes through tax collection efficiency and retribution.

Department of Revenue East Kalimantan Province is the agency charged with promoting local revenue sources among which is sourced from The Local Original Revenue, so as to sustain the independence of financing for development in the area. Data Target Revenue of Local Original Revenue [3] showed an average increase in the target last 5 years (2009 to 2013) was 112.83%. [2] It requires effort and hard work the regional government in achieving revenue sources. Acceptance of local revenue comes from revenue (PAD) own, local revenues derived from the distribution of revenue, financial balance fund between the central government and local governments, regional loan, and the other is the revenue generated by the region itself and an local legitimate income. [4]

Based on the description, the formulation of the problem is: "How can the effectiveness and contribution of The Local Original Revenue, East Kalimantan Province in 2009 until 2013". This study was conducted to measure the effectiveness and contribution of The Local Original Revenue East Kalimantan in 2009 until 2013. Measurement of effectiveness ratio and the ratio of the contribution made to the sources of acceptance Local Original Revenue [4] consists of from regional taxes, local retribution, profit company owned by local, local wealth management results, and other local original revenue.

## MATERIALS AND METHODS

This study is a quantitative descriptive research. It's describes the phenomena or characteristics of the data at the time the research was conducted or during a certain period of time to test and answered questions formulation of research problems. Formulation of the problem is generally expressed in questions. So the theory in quantitative research is used to answer the research problem formulation. [9]

The study was conducted at the Department of Revenue's Office of East Kalimantan Province - Indonesian. The focus of this research is to analyze and discuss the effectiveness and contribution of the sources of regional revenue, East Kalimantan Province during 2009 to 2013. The technique for data analysis as follows:

1. Calculate the Effectiveness Ratio of The Local Original Revenue, constitute: Effectiveness Ratio is used to determine the ability of the government to mobilize revenues The Local Original Revenue is in accordance with the target set. [8] Formula of Effectiveness Ratio to the realization and acceptance of the target sources of local regional revenue, as follows [1]

$$\text{Effectiveness Ratio} = \frac{\text{Realization of Sources acceptance}}{\frac{\text{The Local Original Revenue}}{\text{Target of Sources acceptance}}} \times 100\%$$

The level of effectiveness was measured using the following indicators [6]:

Table 1. Interpretation of Value Effectiveness.

Percentage (%)	Criteria
>100	Highly Effective
90-100	Effective
80-90	Enough Effective
60-80	Less Effective
<60	Ineffective

2. Calculate the Contribution Ratio of The Local Original Revenue constitute: The ratio of the contribution that the analysis used to determine the amount of the contribution of acceptance sources local regional revenue to total revenue. [7]

Rasio Formula of Contribution Ratio to acceptance of sources of local regional revenue, as follows. [1]

$$\text{Contribution Ratio} = \frac{\text{Realization of Sources acceptance The Local Original Revenue}}{\text{Realization acceptance The Local Original Revenue}} \times 100\%$$

The level of Contributions was measured using the following indicators [6]:

Table 2. Classification Criteria Contributions.

Percentage	Criteria
0,00% – 10%	Very Less
10,10% – 20%	Less
20,10% – 30%	Medium
30,10% – 40%	Enough good
40,10% – 50%	Good
> 50%	Very Good

## RESULTS AND DISCUSSIONS

Based on the research results of the analysis of the effectiveness ratio of acceptance The Local Original Revenue, analysis of the contribution to the realization of acceptance The Local Original Revenue to the set targets and to determine the amount of the contribution of regional taxes, local retribution, profit company owned by local, local wealth management results, and other local original revenue. The following data of target and the realization of sources acceptance The Local Original Revenues for 2009 to 2013.

### 1. The Local Original Revenues

In Figure 1, during the years 2009 to 2013 the number of acceptance The Local Original Revenues continues to increase, both in terms of targets to be achieved by the realization of the amount of revenue from The Local Original Revenues. It is shown through Effectiveness Ratio PAD that change fluctuated in meeting revenue targets, the achievement of revenue targets is highly effective 118.90% exceeded the target in 2010. In general, the government's ability to mobilize revenue receipts have exceeded the target set. The Local Original Revenues changes depicted in graphical form below at Figure 1.

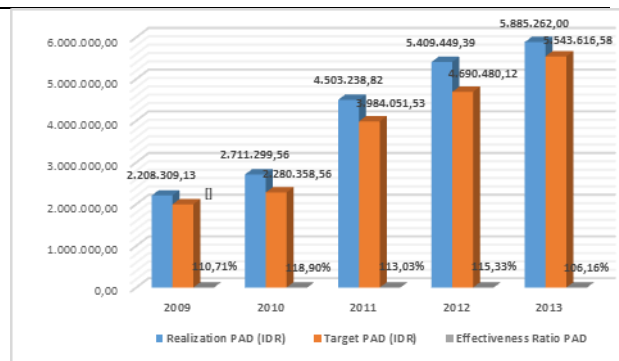

Fig.1. The Local Original Revenue (PAD): Realization, Target and Effectiveness Ratio (million IDR)

### 2. Effectiveness Ratio and Contributions Ratio

The realization of acceptance The Local Original Revenues is very effective for achieving revenue targets that have been set. The realization of acceptance The Local Original Revenues is very effective for achieving revenue targets that have been set (Figure 2).

Realization of The Local Original Revenues is the largest achieved 118.18% (Effectiveness Ratio) through acceptance of other local original revenue (consisting of grant income, adjustments funds and special autonomy, others legitimate local revenue from third parties. This shows the government's ability to mobilize revenue sources The Local Original Revenues increased during the years 2009 to 2013 (Table 3).

Table 3. Recapitulation of Average Effectiveness Ratio and Contributions Ratio, 2009-2011

Source of Acceptance The Local Original Revenues	Average Effectiveness Ratio	Criteria Effectiveness Ratio	Average Contributions Ratio	Criteria Contributions Ratio
Regional taxes	111.99 %	Highly effective	78.56%	Very Good
Local Retribution	111.74 %	Highly effective	0.39 %	Very Less
Results of Regional Wealth Management	106.84%	Highly effective	4.83%	Very Less
Other Local Original	118.18%	Highly effective	10.71%	Less
Average PAD	113.69%		23.62%	

Table 3 shows the local tax contributed very significantly to the sources of acceptance The Local Original Revenues East Kalimantan Province period of 2009 until 2013. Among the types of local taxes that provide great reception is motor vehicle tax. motor vehicle



title transfer fee and vehicle fuel tax.

Receipt of The Local Original Revenues others have not demonstrated a significant contribution to revenue receipts (by 118.18%) showed less contribution (contribution criteria) to overall revenue receipts. When viewed from contribution of receipts others local original revenue Legal as the grant income, adjustments funds and special autonomy, other local revenue from third parties.

Acceptance The Local Original Revenues of generally retribution 117.74% showed less contribution (contribution criteria) to the overall acceptance of The Local Original Revenues. When viewed from the side of the contribution of retribution just retribution public services such as health care, re-calibration services retribution and of the levy charges for services such as the use of regional assets, retribution of place to stay and retribution of local businesses. Acceptance from retribution of licensing revenue receipt amount is still relatively small. Table 1 depicted in Figure 2.

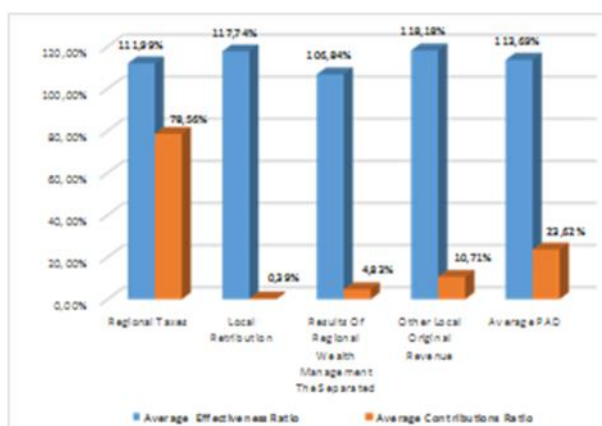

Fig.2.Recapitulation of Average Effectiveness Ratio and Contributions Ratio, in 2009-2013.

Realization Tax revenues as well as the opportunity to be able to maintain and increase local tax revenues and retribution to the maximum in order to sustain the needs of local expenditure and finance the construction of the Province of East Kalimantan. Efforts that may be done include:

1. Intensification activities, consists of: (a) Supervision of Effective in the management and acceptance local taxes and local

retribution; (b) Educative measures to encourage obedience, discipline taxpayers, and a heightened awareness of officials a tax collector and retribution to provide maximum service; (c) Referral and sanctions to the officers and employees in carrying out daily tasks in order to prevent fraud.

2. Extensification activities, consists of: (a) Improving the skills and abilities of officer in providing services to local taxpayers and users of services local businesses; (b) Increase the amount of revenue from retribution because it has not maximal of achievement obtained; (c) Management and improvement of the data base periodically for analysis corrective measures to increase amount of local tax revenue and amount of retribution.

## CONCLUSIONS

Based on the description of the discussion can be concluded as follows:

1. Realization receipts of local tax revenues, East Kalimantan Province was appropriate even exceed the targets set by the average achievement 113.69% (Effectiveness Ratio) to revenues derived from local tax revenues, local retribution, the results of wealth management are separated, and Everything Else Authorized Local Revenue for the year 2009 until the year 2013. Revenue realization of Local Original Revenues highly effective through acceptance Else The Local Revenue legally (118.18%).

2. In terms of the composition of receipts Local Original Revenues, East Kalimantan Province during 2009 to 2013 was dominated / greatest sourced from local taxes contributed 78.56% (ratio Contributions) of the total revenue receipts.

3. On receipt of local retribution, the results of the wealth management area separated contribute very less (criterion between 0.00% to 10%), and other legitimate local revenues have contributed less (criterion between 10.10% to 20%) to the total The Local Original Revenue, East Kalimantan Province in 2009 until 2013.

4. The Government of East Kalimantan province in this case Department of Local

Revenue as acting in the conduct and management of the local tax collection continues to improve the success that has been achieved in view of the potential sources of local tax revenue is huge so if associated with it can be envisaged that the target set still too small compared to the existing potential (78.56%). For it must continue to make revamping and repairs as well as innovative measures both internally and externally to increase local tax revenue and other revenue receipts.

5. Acceptance of local tax revenue, local retribution, the results of which are separated of wealth management, and Others Regional Income Legitimate still need to be improved because of the realization of acceptance has still a very small contribution by also considering the cost of collection and the cost of providing services local. Continuously strive to continuously explore and enhance the potential of the sources receipts of local original revenue.

## REFERENCES

- [1]Abdul Halim, 2001, Regional Financial Management, Publisher: Yogyakarta: UPP STIM YKPN.
- [2]Anonymous, 2014, Summary Budget of Revenues and Expenditures Local East Kalimantan-Indonesian, Regional Revenue Office.
- [3]Anonymous, 2014, The Central Statistics Agency Local of East Kalimantan, Indonesian.
- [4]Anonymous, The Law on Republic of Indonesian, Number 23 year 2014, on Local Government.
- [5]Anonymous, The Law on Republic of Indonesian, Number 28 year 2009, on Local taxes and Local retribution.
- [6]Depdagri 1997, Kepmendagri No. 690.900.327, in 1996. Guidelines for Assessment and Financial Performance.
- [7]Guritno,T., 1997, Dictionary of Economics-business-banking: English-Indonesian. Publisher: Gajah Mada University Press. Yogyakarta.
- [8]Mahmudi, 2007, Management of Public Sector Performance. Publisher: Yogyakarta: UPP STIM YKPN.
- [9]Sugiyono, 2008, Business Research Methods. Alfabeta Bandung





## EVALUATION OF ROMANIAN LIVESTOCK SECTOR FROM THE PERSPECTIVE OF AVAILABILITY OF FOOD PRODUCTS

Mariana SANDU<sup>1</sup>, Steliana SANDU<sup>2</sup>, Marcel Theodor PARASCHIVESCU<sup>1</sup>

<sup>1</sup>Romanian Academy, „Acad. David Davidescu” Centre for Studies and Research on Agricultural and Forest Biodiversity, 13, Calea 13 Septembrie st., 5<sup>th</sup> district, Bucharest, Postal code 050711, Romania Tel./Fax. + 4.021.318.81.06, E-mail: marianasandu47@gmail.com, marceltheodor@yahoo.com

<sup>2</sup>Romanian Academy, Institute of National Economy, 13, Calea 13 Septembrie st., 5<sup>th</sup> district, Bucharest, Postal code 050711, Romania, Tel./Fax.+ 4.021.318.24.67, E-mail: sandu.steliana55@yahoo.com

**Corresponding author:** marianasandu47@gmail.com

### Abstract

*The Food security of the population is a global problem of mankind due to increased demand for agricultural products, driven by population explosion, increasing household income and changing of consumption structure. The major changes that have occurred in the Romanian economy after 1990, there have been felt in animal husbandry, both in terms of size livestock farms and livestock and yields obtained. This scientific approach aims to analyze the Romanian livestock sector in terms of availability and consumption of food products of animal origin. The quantitative and qualitative analysis of the main indicators of production is based on statistical data provided by the National Institute of Statistics and Ministry of Agriculture and Rural Development. According to this analysis of the Romanian livestock sector we conclude that the current level of production is much lower than a decade ago, as a result of the sharp and steady reduction of livestock, reduction of purchasing power of population, poor performance and lack export competitiveness. On the other hand, consumption of food products in Romania is much lower than the EU average consumption, the share of food self-consumption is the highest in the EU-27, while the share of food expenditure in total household expenditure remain at extremely high levels.*

**Key words:** availability, consumption, food security, livestock, productions

### INTRODUCTION

Ensuring the food security for the population is a global problem. Some works estimates that until 2050, it is necessary to increase up to 50-70% the food production in order to feed a growing population of two billion people. [6]

Although worldwide in the last 30 years, in the same time with increasing human population has increased food availability, yet 925 million people are suffering from chronic hunger. [2]

This problem is not only the result of insufficient food production and an inadequate distribution thereof, but also a financial inability of the poor people to buy food of good quality and in sufficient quantities to meet their needs. [3]

Throughout the world, the demand for food of animal origin is increasing due to rapid population growth and its income.

Globally, livestock contributes directly to reducing poverty and enhancing food security, being the livelihood of nearly one billion people of the world population and sources of income and jobs. [1] The three main types of operating systems in animal husbandry: intensive, mixed (crop and livestock) and open (grazing) have a total amount of more than 17 billion animals. [4], [5]

Estimates based on data for the period 2001-2003 suggests that grazing systems contribute 9% of the amount of total meat globally and 12% in the milk; mixed systems contributes 46% to the amount of meat, 88% for milk and up to 50% of the total quantity of grain; [9], [10], while intensive systems provide 45% of the meat produced worldwide.

Livestock is for any national economy, the branch that ensure prosperity, balancing and improving consumption, for better use of feed resources and management of labor. [8]

The share of livestock in agricultural

production is considered an indicator of economic development of a country. [7]

Nationally, livestock production for self-consumption can contribute to food security by avoiding problems that may arise in the supply of food of animal origin imported. Also, for countries that are net exporters, exports of animals have the potential to make an important contribution to the balance of payments. [2]

In this context, the paper presents an analysis of the evolution of Romanian livestock sector in order to highlight the availability and consumption of food products of animal origin.

## MATERIALS AND METHODS

To highlight the relationship between livestock production and food security of the population, this paper aims at analyzing the Romanian livestock sector in terms of availability and consumption of food products of animal origin.

The methodology of this study is based on qualitative and quantitative analysis of the main indicators of livestock production and household consumption of foods of animal origin.

To characterize the evolution of this sector were used the following indicators: total actual animal species, total production obtained, average weight at slaughter, the average annual consumption of food products. The data collected by the National Institute of Statistics and Ministry of Agriculture and Rural Development for the period 2003 - 2013 were statistically processed and interpreted.

## RESULTS AND DISCUSSIONS

The major changes that have occurred in the Romanian economy, since 1990, there have been felt in animal husbandry, the restructuring process of livestock holdings is far from complete.

According to the General Agricultural Census, in 2010 Romania had the highest number of farms, 3,859,000 (32.88% from total holdings of the European Union) on an area of 13.3 million ha (an average size of 3,

45 ha/farm) and 99.2% of all existing holdings were farms without legal personality (individual farms, authorized individuals, family businesses). To this is added the poverty of a large share of people involved in agriculture and a very low level of education (European Commission data for 2010 show that the share of population at risk of poverty Romania was 22%).

Significant decreases in Romanian livestock registered after 1990 were due to both, the massive slaughter of animals following the dissolution of state agricultural units and the difficulties of adaptation to the European veterinary rules after Romania integration in the European Union. In total there was a decrease of livestock owned in small farms but the evolution was different depending on the species.

Table. 1 shows the evolution of the main indicators of animal production in different species in the period 2003-2013. In the period under review, total number of cattle decreased by about 24%, from 2.897 million head in 2003 to 2,197,000 in 2013.

For cattle (RGA 2002, 2010), the sharpest decline was recorded in small farms (number of farms owning an average of 1-2 cows decreased by 54% and those with 3-9 cows by 28%), farms where cattle are bred for family subsistence and the eventual surplus is sold in the form of dairy products in traditional markets. In the same time with the decreasing of total number of cattle, the share of breeding stock showed a similar downward trend (-22.1% in 2013 compared to 2003).

Following the total number of cattle decline, there were decreases in both total milk production obtained (23% in 2013 compared to 2003) as well as in the meat (-38.5%).

However, a positive aspect is given by the steady increase in average productions. The average milk production/ head / year grew by 3.7% and the average weight at slaughter / capita increased by 1.8%. However, the values recorded are well below those achieved in EU countries (eg average production per cow per year is about 8,000 liters in Denmark, Finland and Sweden, and less than 4,000 in Bulgaria and Romania).

Table. 1. The evolution of Romanian livestock sector in 2010-2013

Specification	UM	2003	2004	2005	2006	2007	2008	2009	2010	2011	2012	2013	2013/2010 (%)
<b>CATTLE</b>													
The total number from which:	thousand head	2,897	2,801	2,862	2,934	2,819	2,684	2,512	1,985	2,130	2,164	2,197	75.8
Breeding stock		1,757	1,755	1,812	1,810	1,732	1,639	1,569	1,282	1,312	1,352	1,369	77.9
Average milk production	l / head	3,263	3,493	3,510	3,688	3,564	3,653	3,807	2,595	3,529	3,417	3,385	103.7
Total milk production from which:	thousand hl	55,288	55,444	55,334	58,307	54,875	53,089	50,570	42,824	43,807	42,036	42,600	77.05
Sold production		25,937	27,629	28,000	28,834	26,868	28,197	25,310	17,433	22,321	21,462	21,894	84.4
Total production of beef alive	thousand tons	378	391	383	318	333	306	264	205	289.3	198.5	232.6	61.5
The average weight at slaughter	kg / head	321	328	333	275	280	285	287	264	333	332	327	101.8
<b>SWINE</b>													
Total number of pigs	thousand head	5,145	6,495	6,622	6,815	6,565	6,174	5,793	5,387	4,153	4,011	4,054	78.8
Total production of pig meat alive	thousand tons	710	626	605	618	642	605	585	553	595	555	582	82.0
The average weight at slaughter	kg / head	111	105	103	113	113	114	113	115	107	116	117	105.4
<b>SHEEP AND GOAT</b>													
Total number of Sheep and goats	thousand head	8,125	8,404	8,921	8,406	9,334	9,780	10,059	9,623	11,331	12,298	12,710	156.4
Total production of meat alive	thousand tons	135	166	114	101	110	104	104	100	150	107	171	126.7
The average weight at slaughter	kg / head	23	28	19	18	18	17	17	16	21	18	24	104.3
<b>POULTRY</b>													
Total number of birds	thousand head	76,616	79,360	79,018	84,991	82,036	84,373	83,843	78,867	70,390	71,767	67,989	88.7
Total production of poultry alive	thousand tons	436	372	401	361	416	410	489	446	468	470	485	111.2
The average weight at slaughter	kg / head	1.9	1.9	1.8	1.8	2.0	2.0	2.0	2	2.292	2.042	2.267	119.3
Total egg production	mil.buc	6,641	7,381	7,310	7,429	6,522	6,692	6,211	6,199	5,489	6,398	5,939	89.4

Source: MADR

If we analyze how was used the production obtained from cattle in 2013 (table. 2), we see that from the total production of milk, 39.31% is for family consumption while only 22% of production was taken and processed in units specialized in milk processing. From total meat production, processing by specialized units is still low (22.3%), while direct sales account for 51.9% of total meat production obtained.

In the period 2003-2013, total swine livestock showed substantial decreases due to a lack of financial support, after the accession to the European Union, and the restriction on

exports of pork due to swine fever treatment. Thus, the total number decreased (- 21.2%), from 5,145 million head in 2003 to 4,011,000 in 2013. Although the average weight at slaughter increased by 5.4%, total meat production obtained fell 18%, due to the decrease of total number of pigs ((table. 1). The average size of pig farms (RGA 2010) 3.14 heads / farm shows a large number of subsistence farms producing for family consumption.

From the analysis of data on the use of pork production, we observe that the share of consumption for family is 32.1% from the

production obtained, the remaining 67.9% of the meat being sold on the market (table. 2).

Traditionally, pork has a large share in the consumption pattern of Romania, competing with poultry. Consumption in absolute terms

was in 2010 and 2011, approximately 30 kg / capita / year, below the EU average (37 kg / capita) and countries such as Germany (40 kg / loc.), Austria (57 kg / person. ), Hungary (44 kg / loc.).

Table 2. Recovery yields obtained in animal husbandry in 2013

Specification	Production		Technological consumption		Family consumption		Total sales for market		Sales to industrial units		Direct Sales	
<b>Cow milk</b> (thousand hectoliters)	42,600	100	3,960	9.3	16,746	39.31	21,894	51.39	9,412	22.09	12,482	29.3
<b>Beef meat</b> (thousand tons)	232.6	100	-		60,011	25.8	172,59	74.2	51,87	22.3	120,72	51.9
<b>Pig meat</b> (thousand tons)	582	100	-		186,822	32.1	395,18	67.9	319,52	55	75,66	13
<b>Sheep and goats meat</b> (thousand tons)	171	100	-		57,63	33.7	113,37	66.3	102,60	60	10,77	6.3
<b>Poultry meat</b> (thousand tons)	485.2	100	-		67,9	14	417,3	86	375,1	77,3	42,2	8,7
<b>Eggs</b> (million units)	5,939	100	320	5,4	2,660	44.8	2,957	49.8	1,110	18.7	1,847	31.1

Source: MARD, data processed by author

The only species that have recorded significantly risen are sheep and goats, Romania becoming one of the leading European producers in this sector.

From the total livestock of sheep, the increase was higher in farms with over 100 animals, due to the context of export opportunities in European markets and in the Middle East. In goats, herd growth occurred in small farms (1-9 heads) and in medium farms (over 200 heads goats) due to production characteristics of the species, low maintenance costs and consumer preference for the products.

During the period under review, total number of sheep and goats increased by over 33%, from 8.125 million head in 2003 to 12,710,000 in 2013. The same trend was manifested both in terms of total meat production (+ 26.7 %) and average weight at slaughter (+ 4.3%), (table. 1).

If we analyze how was used the meat production obtained in 2013 from sheep and goats, we find that 57 627 tonnes (33.7% of total production) is for family consumption and 113,373 tonnes (66.3%) is sold on the

market, mostly (60%) for processing units (table. 2).

The total number of birds decreased by 11.3% between 2003-2013, while total production of live poultry meat has increased by over 11.2%, due to higher average weight at slaughter by 19.3% (table. 1). According RGA 2010, 60% of the total number of birds is found in poultry farms under 100 heads, respectively, in rural households and their production, mostly used for own consumption.

From table. 2, we see that in 2013, for the production of poultry meat, the family consumption related to the total output obtained is lower (14%) than in the case of egg production (44.8%). Significant differences are in the sale for market from the production of meat and eggs. For meat production, the share for the sold quantity is 86% of total production obtained, while for the eggs, it is only 49.8%.

In Romania, food consumption shows negative aspects both economically and socially. The share of food expenditure in

total household expenditure levels remain extremely high, about 40-45%, values twice as high compared to the EU average. From the total food expenditure, expenditure on imported foods have a high percentage, 34.1% respectively. The share of food self-consumption is the highest in the EU-27, and food consumption per capita in Romania is at the minimum level of subsistence, approximately 2.2-2.5 times lower than the EU average consumption.

According to INS data, in 2013, an average Romanian consumed about 54.4 kilograms of meat and meat products, milk and dairy products 244.5 kg and 247 eggs. From the

total meat consumption, 29.1 kg is the consumption of pork, poultry 17.5 kg, 5.1 kg beef and 2.4 kg meat of sheep and goats (table. 3).

If we analyze the evolution of consumption of agricultural products, we find that overall meat and meat products, the average consumption fell by 4.1% in 2013 compared to 2003 due to the deterioration of the purchasing power of the population. On different meats, the only growth of average consumption was recorded in pork (+ 18.3%). Light increases in average consumption were also recorded for milk and milk products (+ 5.4%) and eggs (+ 2.5%).

Table 3. Evolution of consumption of agricultural products

<i>The main agricultural products</i>	<i>U.M.</i>	<i>2003</i>	<i>2004</i>	<i>2006</i>	<i>2008</i>	<i>2010</i>	<i>2011</i>	<i>2012</i>	<i>2013</i>	<i>2013/2003 (%)</i>
<b>Meat and meat products (total)</b>	<i>Kg</i>	56.7	61.6	65.9	66	59.9	56	55.3	54.4	95.9
<b>Beef meat</b>	<i>Kg</i>	8.7	9.3	9.8	8	5.7	5.5	5	5.1	58.6
<b>Pig meat</b>	<i>Kg</i>	24.6	28.7	32.1	34.6	33.3	30.5	29.6	29.1	118.3
<b>Sheep and goats meat</b>	<i>Kg</i>	2.9	3.3	2.2	2.5	2.3	2.3	2.4	2.4	82.7
<b>Poultry meat</b>	<i>Kg</i>	20.2	20.1	21.8	20.1	18.2	17.5	18.2	17.5	86.6
<b>Milk and milk products (excluding butter)</b>	<i>Kg</i>	232	247.5	258.9	274.6	244.2	248.5	240.7	244.5	105.4
<b>Eggs</b>	<i>Buc.</i>	241	292	282	280	253	264	245	247	102.5

Source: INS, TEMPO-Online

## CONCLUSIONS

From the analysis of data for Romanian livestock sector we conclude that in some species important for ensuring meat needs of the population, respectively, cattle, pigs and poultry, livestock decreased steadily. Thus, in the period under review, total herds of cattle decreased by about 24%, the swine by 21.2% and the birds by 11.3%.

Among the causes which contributed to the reduction of livestock we can include: poor organization of the livestock sector, the quality of products obtained, difficulties of adapting to European animal health conditions and not at least the economic crisis that diminish domestic demand for meat and meat products.

Sheep and goats are the only species whose

total rose by over 33% is due to both increasing domestic demand for these products and export opportunities.

In the same time with the decreasing of the livestock were recorded also reductions in the levels of total productions.

A positive aspect is given by the steady increase in average yields. However, the values recorded are well below those achieved in EU countries (eg average production per cow per year is about 8,000 liters in Denmark, Finland and Sweden, and less than 4,000 in Bulgaria and Romania).

Consumption of food products in Romania show negative aspects both economically and socially. The share of food expenditure in total household expenditures are approximately 40-45% and per capita food consumption is at the minimum level of

subsistence, approximately 2.2-2.5 times lower than the EU average consumption.

To assure a production that meets inner consumption needs and also availability for export, animal breeding, aimed equally the existence of appropriate numeric livestock, a race structure with a high genetic value and use of modern technologies.

## ACKNOWLEDGEMENTS

This paper has been financially supported within the project entitled ***“Horizon 2020 - Doctoral and Postdoctoral Studies: Promoting the National Interest through Excellence, Competitiveness and Responsibility in the Field of Romanian Fundamental and Applied Scientific Research”***, contract number POSDRU/159/1.5/S/140106. This project is co-financed by European Social Fund through Sectoral Operational Programme for Human Resources Development 2007-2013.

**Investing in people!**

## REFERENCES

- [1]Chiritescu Vergina, Ipate Iudith, Gavrilesco Camelia, Kruzlicika Mihaela, Sandu Mariana, 2014, Food security as long-term goals of strategic agricultural development, Bulletin USAMV series Agriculture, 71(1) , Cluj-Napoca, pp.26-31.
- [2]FAO, 2011, World Livestock 2011, Livestock in food security, Rome, FAO
- [3]FAO. 2012, Livestock sector development for poverty reduction: An economic and policy perspective— Livestock’s many virtues. FAO, Rome
- [4]Herrero, M., Thornton, P.K., Notenbaert, A., Msang, S., Wood, S., Kruska, R., Dixon, J., Bossio, D., Van de Steeg, J., Freeman, H. A., Li, X., Parthasarathy Rao, P., 2009, Drivers of change in crop–livestock systems and their impacts on agro-ecosystems services and human well-being to 2030. CGIAR System wide Livestock Programme. International Livestock Research Institute, Nairobi, Kenya. Google Scholar
- [5]Herrero, M., Grace, D., Njuki, J., Johnson, N., Rufino, M., 2013, The roles of livestock in developing countries. Animal (in press). Google Scholar
- [6]Ingram, J., Ericksen, P., Liverman, D. (ed.) 2010, Food security and global environmental change. Earthscan, London. Google Scholar
- [7]Oancea, I., 1998, Tratat de tehnologii agricole, Ed. Ceres, București.
- [8]Sandu Mariana, Tobă George Florea, Paraschivescu Marcel Th., 2014, Bioeconomical research on

biodiversity of animal food resources in Romania, Romanian Biotechnological Letters, Vol. 19(4): 9597-9604.

[9]Steinfeld, H., Gerber, P., Wassenaar, T., Castel V., Rosales, M., de Haan C., 2006, Livestock’s long shadow: Environmental issues and options. FAO, Rome. Google Scholar

[10]Thornton, P. K., Herrero, M., 2009, The inter-linkages between rapid growth in livestock production, climate change, and the impacts on water resources, land use, and deforestation. World Bank Policy Research Working Paper, WPS 5178. World Bank, Washington, DC., Google Scholar

[11]www.madr.ro

[12]www.insse.ro

[13]www.ec.europa.eu

## EVOLUTIONARY BENCHMARKS OF AGRICULTURE AND RURAL DEVELOPMENT IN THE REPUBLIC OF MOLDOVA

Olga SÂRBU

State Agrarian University of Moldova, 42 Mircesti Str., Rascani District, Chisinau, MD-2049, Republic of Moldova, Phone: +373 22 432387, Email: o.sarbu@uasmd.md

### *Abstract*

*Agriculture continues to be the largest user of rural land and a key determinant of the rural development quality. The importance and relevance of the agriculture and rural development in the Republic of Moldova have increased with the enlargement of the EU and prospects of our country in this context. The present study proposes an analysis of the evolution of agriculture in its many aspects, focusing on rural development concepts in terms of durability and multifunctionality. During the research have been used traditional research methods quantitative and qualitative analysis, comparative and logical analysis. Preference was given to monographic study method applying the elements of observation, selection, induction and deduction. Investigations conducted allow us to conclude that accelerating reforms outlined in the agro-food sector will contribute to the formation of new enterprises, efficient functioning of market mechanisms, modernizing techniques and technologies, improving the legal framework in agriculture, increase the degree of diversification of the rural economy; educating economic behavior of farmers and creating a flexible mindset to various changes. All these would contribute to supply a competitive and efficient agriculture that would allow its integration in the European markets.*

**Key words:** agriculture, rural development, rural economy

### INTRODUCTION

The problem of rural areas development and planning is one of the most important problems of the mankind as it requires a balance between the need of preserving rural economic, environmental and social areas and the logical trend of improving the rural life. Therewith, rural development and planning is co-influenced by both the tendency of urban areas expansion and the industry development on account of rural areas and the need to preserve the current share of rural areas as far as possible. The targets of the major interest for any nation are to maintain and preserve the national character of rural areas and culture. The concept of rural development covers all the actions aimed at improving the life quality of the people who live in rural areas, preserving natural and cultural landscape and ensuring the sustainable development of rural areas in accordance with the conditions and specific character of those territories. We ultimately tend to make rural areas suitable for fulfilling their functions in the society sustainably. The development is a dynamic phenomenon that is extremely complex and difficult to define. Over the years, the focus has shifted from the economic

to the social or human development.

Rural problems, namely their acknowledgement, research, development and improvement are the complex activities of the vital importance for any country, their solution cannot be solved by short-term activities. Thus, one needs successive integrated programs with lasting effects which result in the improvement of human and institutional conditions. The European Charter of rural areas presupposes that one should take into account specific conditions of rural areas and respect the principles of subsidiarity and solidarity when working out rural development policies. The rural development is related to the Common Agricultural Policy and the measures that support employment. Its main objectives are the following: the modernization of farms and providing financial support for young farmers; the promotion of tourism infrastructure and encouraging local activities; providing better access of the population to services; the depopulation prevention in rural areas by assuring the professional development of the workers in small firms. Rural development programs are often complex and at the same time they can be applied to several sectors: infrastructure, agriculture, tourism

(agritourism and rural tourism), small and medium enterprises, job creation, environmental protection, education, community development, etc. Human resources, local communities, participants in the economic and social life, environmental and cultural landscape values play an important role in rural development.

Acknowledgement, research, improvement and development of rural areas are the activities of the vital importance for a country both by rural areas dimension, expressed by the area owned and the share of the population employed in productive activities, such as social and cultural, housing and tourism services. The problem of the rural economy development is one of the most difficult nowadays. Its essence involves achieving a balance between the requirement of the rural economic development in terms of the economy, environment and culture and the tendency of rural life continued modernization. However, the rural economy development is also influenced by the tendency of urban areas expansion and the requirement to maintain the current size of rural areas.

## **MATERIALS AND METHODS**

Both publications in journals and materials of national and international conferences have been used as the theoretical support. To reveal the matter we have conducted research based on the data provided by the National Bureau of Statistics. This statistical information has been used to quantify the progress that occurs in production, to learn the distribution of the rural population in different sectors, to watch the evolution of the rural population share, to analyze the situation in agriculture, etc. Various methods of economic analysis were used to study the actual conditions and resources in agriculture. The analysis of statistical indicators, which involves researching agriculture in terms of the indicators that quantify the role of agriculture in the economy, the agricultural potential, the potential of agricultural enterprises, the economic efficiency of the agricultural production, etc. The analysis of the

quantitative indicator system gives a possibility to those who study agriculture as an economic branch to create a “still” picture about its realities, and to identify the ways and development strategies of the analyzed agricultural phenomena by the correlation with the qualitative analysis. The SWOT analysis provides a comprehensive picture of the agricultural production systems and units by the simultaneous research of both internal characteristics and external influences upon them, taking into account both positive and negative variables. The comparative analysis, which is based on comparing the results of some agricultural policy measures, some management methods and the overall comparison of some exploitation systems of agricultural resources. The regional analysis aims to identify geographic, demographic and economic variables which characterize agricultural areas. The direct observation, which offers the possibility to capture as many aspects of the studied phenomenon as possible, using monograph and economic study as the main processes.

## **RESULTS AND DISCUSSIONS**

The rural development has multiple coverage areas from the conceptual point of view:

- the local rural development includes concepts related to the development of a settlement and its surroundings, aims at local communities (villages, communes) and households;
- the territorial (or regional) rural development refers to large investments, the development of infrastructure at the regional level or aims at more regions created by the regional interdependencies;
- the border rural development is created by means of economic, social and cultural relationships between border communities of different countries and is aimed at the development of those areas;
- the paneuropean rural development is characterized by the phenomenon extent at the European level.

The sustainable rural development is part of the concept and the strategy of the economic and social sustainable development. We distinguish two important concepts in the



rural development: the sustainable and integrated rural development. The concept of the sustainable rural development appeared after the UN Conference on Environment (Rio de Janeiro - 1972) and the establishment of the World Commission on Environment and Development (1985).

The coordinates of the sustainable rural development must start from the three-dimensional analysis (economic, social and ecological) of rural areas. Three-dimensional spatial relationships confirm that any action or phenomenon that occurs in the plan affects other plans as well. For example, an economic decision that is considered to be viable should not be applied in practice without the analysis of its influence on the social and environmental situation. The adoption of a decision that is good from the economic point of view can have negative effects from the social or ecological point of view.

In order to establish certain development strategies and avoid negative effects it is required to form some multidisciplinary mixed groups aimed at making decisions.

The economic sustainable development concerns the economic diversity, access to services and environment protection that are necessary to ensure the success and sustainability of the rural development. The rural development should be also viewed from the global perspective of the European Union. In order to halt the decline of rural areas one needs to organize the territory so that it becomes less dependent on economic centres. Then we must make sure that there is a market for our products, watch the evolution of this market over time and adjust to the market demand on the fly. We also need a work team, family or other members. The enrolment in a core association could be useful, especially in the segment of information supply and production disposal. Like any action or activity, the economic development must be carried out under the conditions of profitability and realized in all directions in order to have strong and viable business enterprises, as agriculture is the main determinant of the rural development in most rural areas. This does not mean that the rural development is restricted to the development

of agriculture. Agriculture is the main sector in the countries with the developing economy. The principles of the sustainable rural development at the economic level are: the prosperous, competitive and efficient rural economy; the sustainable and competitive agriculture to provide adequate supply of healthy food and satisfy consumers' needs; the diverse and dynamic economy with local initiatives and services to create jobs.

The sustainable development of rural areas from the environmental point of view should be coordinated with the economic and social development and avoid environmental degradation. The environmental protection is the cornerstone of the sustainable development and must be consistent with the principles of the sustainable agricultural practice [5]. At present the vast majority of farmers use a certain amount of fertilizers and chemical pesticides in order to increase the yield per hectare. The higher the doses, the more evident the negative effects on the environment and natural ecosystems.

Under the current situation in our economy it is necessary to find an optimal balance between the cultivated technologies, obtained yields and ecology to ensure the socio-economic development of rural communities through: the promotion of ecological land use practices and rational use of resources (soil, water, energy, ecosystems), especially at the level of farms; the conservation of habitat and landscape diversity (simultaneously with farming practices); ensuring the constant number of the population; satisfying food and social demands; the improvement of the environment and natural resources quality; the most efficient use of limited and non-renewable resources; the improvement of the life quality.

The sustainable agriculture practice aims at: maintaining soil quality and ensuring the optimal correlation between food quantity and quality, people's health and environmental quality. These balance correlations can be ensured by practicing alternative agriculture whose objective function is driven by environmental and production restrictions. The following activities have to be implemented: crop rotation; recycling of crop

residues and manure; the use of chemical fertilizers, pesticides and other chemicals in limited doses; the spread of crops for soil protection and improvement including nitrogen-fixing legumes; the integrated control of pests and diseases.

Acting in the spirit of sustainable development one should avoid soil degradation because of economic reasons at all costs, the results of the latter are expected in the short term but there may be some negative effects in the medium and long term.

The sustainable development of rural areas is not only obtaining ecologically friendly agricultural products of good quality, it also implies the assistance in agricultural products processing based on technological procedures.

When realizing investment projects, the people involved in raw material processing are generally interested in the indicators of economic efficiency, profitability of recovery yields and the ones aimed at the extraction of useful substances, pursuing the economic development. The strategies of sustainable development make them to analyze the projects from the ecological point of view, which usually leads to the increased costs.

The main objective of the rural development policy is to maintain the existence of rural communities: the competitiveness of agriculture is essential but not sufficient. The economic diversification, access to services and environmental protection are necessary to ensure the success and sustainability of the rural development. The rural development should be also viewed from the global perspective of the European Union.

The optimum of the sustainable socio-ecological development is the increased accessibility to environmentally friendly measures by adopting the most viable alternatives that satisfy all the mobility requirements of the society; ensuring the transparency of measures and their explanation, while encouraging public participation in the discussion of the usefulness, scope and cost of these actions; the assessment of the social and environmental impact before taking any actions; providing permanent information and instruction in the spirit of environmental

measures promotion; giving priority to the development of transportation systems in favour of ecological ones, with the minimal or no negative impact; the reorientation and reorganization of all transport modes towards environmental measures; the minimization of waste production and disposal for each stage of the life cycle of vehicles, along with their recycling; the prevention of habitat degradation, division of ecosystems and loss of land for agricultural or social purposes.

The sustainable development of rural areas from the social point of view consists in assuring living conditions at the level of human conditions for all settlements and regions where this activity is present. Not all regions provide the same conditions for the economic and social development. The differences occur because of the natural conditions and the level of regions development from the economic point of view. The social development of a region is correlated with its economic development and is dependent on it. The more prosperous the region from the economic point of view, the fewer adverse effects leading to social regression. The level of the economic and social development varies from one region to another and from one community to another in the Republic of Moldova. Huge discrepancies appear in the same community, where we meet social groups that are more or less prosperous.

The sustainable rural development must be understood as a logical mechanism which acts to direct the economic and social development of the countryside phenomena towards the individual and community development leading to the improved rural welfare and the balance of natural factors. One may improve the welfare of rural areas by: stopping the migration of the population from rural to urban areas; by creating alternatives to motivate the existence and to stimulate initiative in order to provide all the things that are necessary for living; by fighting poverty; stimulating and diversifying services; ensuring minimum living conditions for the rural population compared to the urban population; the right for a better life, health care, education and social protection.

The sustainable development of rural areas cannot be worked out without some viable solutions for the myriad of social problems and the rural infrastructure which will provide minimum comfort for community members.

The reforms promoted in the rural economy of the Republic of Moldova have led to significant changes in this field. The structure of the agriculture has been changed; new forms of organization have appeared, such as: farm enterprises, farms and individual enterprises. Some fixed means of production in agriculture have been provided, the era of guaranteed sales for fixed prices under the conditions of domestic demand unlimited capacity for agri-food products is over; competition as a market element has appeared. This has led to the polarization of farmers, separation of a small number of efficient and competitive producers, marginalization of a significant number of other producers on the one hand, and to the appearance of unemployment, lower living standards in rural areas on the other hand.

At present the countryside is undergoing the processes of depopulation and population ageing, which means a decrease of the available labour force and a lower rate of the older generation replacement, as well as a lower employment potential. The professional status of farmers, the polarized structure of the used lands and the economic size of farms indicate the existence of a large number of agricultural enterprises with low efficiency and thereby reduced potential for growth. Most of the farms are not integrated into the market economy, practicing subsistence agriculture; the low level of education and participation in vocational training in rural areas is a significant competitive disadvantage and a reduced growth potential in the context of knowledge-based development. However, the data show that the low level of education is also associated with lower rates of employment.

The rural economy occupies the key and priority place in the general process of social and economic recovery of the country, and agriculture is its essential part. Therefore, the efficient development of agriculture is an objective necessity. To achieve this objective

one needs a continuous development and improvement of the material and technical basis, the application of new technologies in production, the practice of scientific agriculture in order to create viable business enterprises that will be competitive in the market economy where nothing but the products in demand are produced, the transfer of the whole system of organization, operation and management of the economic agent, by introducing new management, marketing and economy principles [10].

Agricultural activity differs from industry and other sectors by certain peculiarities that greatly influence production, market and profitability of products, which requires necessary guidance and regulation mechanisms of the agricultural supply against the demand evolution. Some of these features consist in the fact that:

- production has a cyclical character, caused by some natural and biological factors as manifested by the seasonal nature and instability of production and farm incomes. There are some other characteristics that determine slower processes of the economic growth in agriculture as compared to other economy sectors;
- high cost of transportation in agriculture, the natural risk and high prices of industrial origin materials that make the cost of commodity delivery become higher than numerous issues on agricultural wages;
- the supply and demand for agricultural products differ from other products due to the difficulty to adopt a relatively stable and less elastic demand to the offer that is varied and difficult to change in the short term;
- significant amounts of secondary products are obtained in the agricultural production (both plant and animal sectors) along with the main products.

The rural economy of the Republic of Moldova is greatly dominated by agriculture; therefore, it is very poorly integrated into the market economy. Agriculture is a priority branch, which needs to be fully integrated into the national economy and increase the role of its structuring and training factor in accordance with the principles of the free

market [8]. The economic and social progress under contemporary conditions is closely related to the development of agriculture and its ability to meet vital demands of the population as well as the demand for raw materials of the industry sector (Table 1). Nowadays agriculture remains a key sector of the Moldavian economy. The dominance of agriculture in the economy of the Republic of Moldova is due to its moderate climate, fertile soil and rich labour resources. The importance

of this sector is also explained by the fact that it produces about 12% of GDP, 53% of the population lives and works in rural areas, 27% of the labour force is employed in agriculture. However, a person of the working age employed in agriculture feeds on average 2.5 people from urban areas. There are on average 15 non-farmers per farmer in Europe while this indicator is 1.5 people in the Republic of Moldova.

Table 1. The place of agriculture in the economy of the Republic of Moldova

Indicators	2004	2005	2006	2007	2010	2009	2010	2011	2012
The share of the rural population in the total population, %	59	59	59.1	58.7	58.7	58.6	58.6	58.4	58.3
The share of the employed rural population in the total employed population, %	56.8	56.5	55.4	56	55.3	53.7	52.9	52.6	51.7
The share of the population employed in agriculture, %	40.5	40.7	33.6	32.8	31.1	28.2	27.5	27.5	26.4
The share of agricultural lands in the land fund, %	57.7	57.7	57.7	58.5	58.5	58.6	59.3	59.4	59.4
The global agricultural production at current prices, million lei	11,819	12,688	13,734	12,825	16,503	13,300	19,873	22,619	19,693
of which:									
- plant production	7,900	8,449	9,079	7,941	10,600	7,861	13,616	15,751	10,776
- animal production	3,524	3,851	4,278	4,509	5,519	4,987	5,789	6,347	8,417

Source: developed by the author based on NBS, [2]

The most important products include fruits, vegetables, tobacco, grapes, wheat, corn, sunflower and animal products

The rural population of the world, especially of the developed countries, is being continuously reduced, including the Republic of Moldova. The permanent reduction of the rural population, but not the one employed in agriculture endangers the environment. This reduction occurred primarily due to the modernization of agriculture, but the more industrialized and intensive agriculture, the greater its impact on the environment. Under these conditions, a reduction of about one third of the rural employed population corresponds to the more than doubled reduction (55.4 %) of the staff employed in agriculture. In 2004 the share of the population employed in agriculture was 40.5 %, while at the end of 2011 it decreased to 27.5 %, or by 13 per cent.

The Republic of Moldova has always been recognized by its fertile land and agriculture, the backbone of its economy. The black soil of the Republic of Moldova is among the

most fertile soils in the world. The land fund of the Republic of Moldova is 3,384.6 thousand ha, its destination slightly varies. The arable land constitutes about 74 % of the total agricultural land area of 3,384.6 thousand ha, it is the highest percentage in Europe. The share of the agricultural land increased in the land fund from 57.7 % in 2004 to 59.4 in 2011, or by 1.7 per cent.

The agricultural sector had a relatively big share in the economy of the Republic of Moldova until 2002. The dynamics demonstrates the tendency of GDP increase, but the share of agriculture has a reversed trend. In 2004-2009 the contribution of agriculture to GVA decreased from 20.4% in 2004 to 10.1% in 2009, having insignificantly increased to 14.7 % in 2011 (Figure 1).

According to the final results of the General Agricultural Census (GAC) in 2011, there are 902,214 farms in the Republic of Moldova, of which 99.6 % is unincorporated entities and 0.4 % is legal entities. The number of active farms is 848,637 (they use agricultural land and / or breed livestock and / or poultry), and

53,577 farms are registered as temporary inactive entities (they own land, but they do not use it and do not breed livestock and / or poultry). The farms have a total of 2,243,540.02 ha, of which the used agricultural area (UAA) is 1,940,135.56 ha, distributed among 846,981 farms. The average UAA per farm is 2.29 ha, which is similar to that recorded at about 49% of all farms in the EU-27, which, according to the 2010 census, had on average less than 2 ha.

Moreover, the UAA per capita is 0.54 ha, which has placed Moldova above the average UAA per capita registered for the EU-27 (0.34 ha UAA per capita).

Approximately 57% of the total area is used under the full ownership by 97.2% of farms, about 25% of the total area is fully leased and used by 0.3% of farms, 15% of the area is exploited by 1.4% of the total number of farmers in the form of mixed ownership (owned and leased).

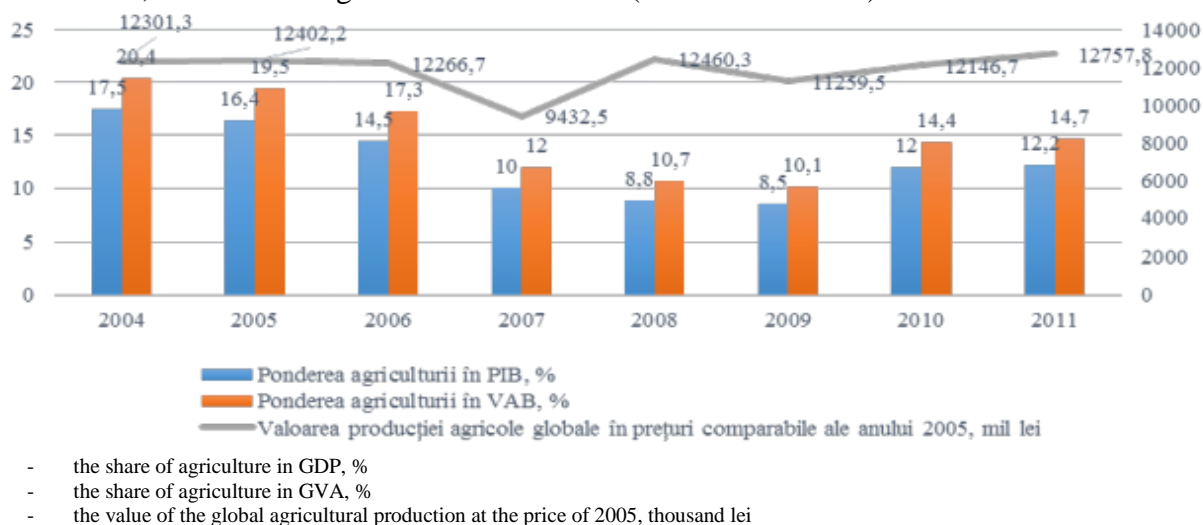

Fig.1. The dynamics of the global agricultural production and the share of agriculture in GDP and GVA in the Republic of Moldova in 2004-2011

Source: developed by the author based on NBS, [2]

The remaining 3% of the total area is used by 1.1% of farms that operate under other types of land ownership. The UAA distribution was not homogeneous within the classes of land area. The census results indicate that the largest percentage of farms is grouped in the class of the smallest land area. Thus, about 71% of farm enterprises have less than 1 ha and the area used by them is 10.1% of the total UAA. The farms from the 1-5 ha category (27% of the total number of farms) use 19.3% of the total UAA. 0.3% of farms with large areas (at least 100 ha) are situated at the other end of the scale, using 63.4% of the total UAA. About 73% of the total UAA is used as arable land, placing Moldova above the EU-27 average in terms of this category share in the total UAA (60%). The arable land is generally the area which is regularly used (ploughed) in the crop rotation system. Pastures cover almost 17% of the UAA,

representing almost half of the registered share of this category at the EU-27 level (30%) [7].

The agriculture of our republic is characterized by the increased economic and social costs. The socio-economic consequences of the implemented reforms in agriculture are not immediate. New types of business enterprises created in the sector and their modernization require a long period of time, which is directly related to the maturity degree of the land market and increased technical equipment and technology.

Agriculture reforming and improvement has not reached its goal yet. Although private ownership prevails in the structure of agricultural land by the type of ownership, these changes are mostly formal. The newly formed business enterprises use old management and remuneration models, the technology, work and sale system. There is

also no healthy competition in the agricultural market because of some regulatory, technical, economic and information barriers. Both large and small businesses of this sector are highly leveraged; the demonetization of the rural sector blocks the agri-food sector [6].

The Republic of Moldova is actively seeking foreign direct investment. In 2011 FDI flows amounted to 274 million euro, with an increase of 44.5% compared to 2010. In 2011 FDI was 3.91% of the country's GDP. Nevertheless, agriculture remains unattractive for FDI. This is partially because agriculture and industry have necessary long-term investment and one needs a political and economic stability as well as predictability.

Rural areas lag behind urban ones in terms of the main indicators of economic well-fare, having recorded lower revenues, higher rates of poverty, low employment and lower indicators of health and education. The economically active population from rural areas has to either accept jobs that are modestly paid or migrate to urban areas in order to find more attractive and better paid jobs or go abroad looking for the job that would provide necessary income to maintain themselves and their family. Nowadays rural areas become less populated, and those who remain there are mostly the people aged up to 16 years old, i.e. pupils and the elderly, i.e. retired people.

Table 2. The analysis of the rural population dynamics by its participation in the economic activity of the Republic of Moldova

Indicators	2003	2004	2005	2006	2007	2010	2009	2010	2011	2012
The number of the rural population, thousand people	2,134.2	2,129.5	2,124.4	2,120.1	2,103.1	2,096.6	2,091.4	2,087.0	2,078.7	2,073.8
The share of the rural population in the total population, %	59.0	59.0	59.0	59.1	58.7	58.67	58.6	58.6	58.4	58.3
The total active population, thousand people	810.9	786.7	776.2	739.4	724.5	710.9	669.6	639.6	650.8	617.0
of which:										
- the employed	774.5	747.3	745.1	696.4	698.6	691.8	636.1	605.0	616.7	592.8
- the unemployed (ILO)	36.4	39.3	31.2	43.1	25.9	19.1	33.5	34.6	34.1	24.2
The activity rate, %	49.3	47.7	46.4	43.7	43.1	42.2	39.3	37.5	38.0	36.0
The employment rate, %	47.1	45.0	44.5	41.2	41.6	41.0	37.4	35.4	36.0	34.6
The unemployment rate, %	4.5	5.0	4.0	5.8	3.6	2.7	5.0	5.4	5.2	3.9

Source: elaborated by author based on data of NBS, [2]

More than half of the population is rural inhabitants – 2,073.8 thousand people. The share of the rural population of the Republic of Moldova is bigger as compared to other countries in the region and exceeds 58%.

The main indicators of the labour force participation in the economic activity in rural areas show a continuous decrease over the past years. Thus, from 2003 till 2012 the economically active population decreased considerably from 810,900 to 617,000 people (or by 24%), the number of the employed was reduced from 774.5 to 592.8 thousand people. Seasonal fluctuations in employment that occur during the year are quite alarming too; they are mainly driven by the agricultural character of the economy. For example, in the first trimester of 2012 the number of the employed in rural areas was approximately 26% less than in the second trimester. The

dynamics of the employed population for the period 2003-2012 is characterized by the higher average figures in the trimesters II and III (704,000 and respectively 707,000 people) and the lower ones in the trimesters I and IV (533,000 and respectively 572,000 people).

However, according to the ILO data, the number of the unemployed has been reduced from 36.4 thousand people in 2003 to 24.2 thousand people in 2012. The weaker consolidation of the labour market relationships in rural areas on the one hand and the lack of employment opportunities in these regions, on the other hand, results in a reduced flexibility of the market and, therefore, an increase in the number of the unemployed.

The activity rate in rural areas has been continuously reduced from 2003 till 2012. So in 2003 this indicator was 49.3%, in 2012 it

fell to 36.0%. This contributed to the decrease of the employment rate from 47.1% to 34.6% in the studied period.

The unemployment rate decreased from 4.5% in 2003 to 3.9% in 2012 in rural areas. But in recent years this indicator increased and was 5.4% in 2010, which is only 0.4 per cent less than in 2006.

The unemployment rate fell to 6.6% in 2011 (it was 7.4% in 2010) due to new jobs in industry and agriculture. More than 27.52% of the working population is employed in the agricultural sector, generating about 12% of the country's GDP. 25% (80,700 people) of the total labour force in agriculture are employed directly by agricultural enterprises and 75% (242,300 people) of them are classified as self-employed.

Incomes from agricultural activities are low. Household incomes from agricultural activities have been decreasing over the years, from 28.4% in 2007 to 19.1% in 2010. Meanwhile, in 2010, remittance incomes accounted for 22.8% of the household incomes. A recent study luckily shows that more than 10% of remittances are directed to the investment in agricultural enterprises to purchase new lands, buildings and equipment for farms [3].

The difficulties faced by the rural labour market led to an intensified reduction of the employment in rural areas. Thus, differences in employment in urban and rural areas of the country become more pronounced and the gap is likely to deepen. Rural infrastructure remains in poor condition. Roads, electricity and water for household and irrigation needs have the greatest negative impact on the agricultural income [1]. It is reported that more than 90% of the water supply systems from rural areas need to be repaired or reconstructed. The government, with the World Bank support, is implementing a comprehensive reforming program at the national level aimed at optimizing the network of schools and improving the efficiency and effectiveness of education. Waste collection covers 100% of the urban areas, while these services are not available in rural areas. Moreover, there are only 180 ha that can be used for recycling in the Republic

of Moldova, while the area of dumpsites is 1,800 ha [9].

The development of the agri-food sector must become one of the strategic national priorities because of the natural, social and economic traditions and experience. To achieve this goal one needs to create a competitive, efficient and sustainable agri-food system, which enables efficient use of the production potential and ensure food security; to restructure, modernize and efficiently use of agricultural enterprises; to redevelop agricultural land in accordance with ecological principles; to review the structure of the agricultural production according to the demands of both internal and external markets as well as to the environmental conditions; to specialize in obtaining agricultural organic products and to increase productivity; to diversify the rural economy.

## CONCLUSIONS

The success of agriculture and farmers in Moldova depends on the compliance with international standards and quality systems. The modernization of the Moldavian quality management, food safety, animal and plant health are of the major importance to maintain access to the profitable market segments, to achieve and increase access to new export markets through diversification, particularly since the EU enlargement. The replacement of the existing system of mandatory standards and overlapping inspections with the system based on fewer mandatory regulations, voluntary standards and dynamic inspections will reduce costs, increase competitiveness and improve food safety and agricultural health. The government has approved the national strategy for 2011-2015, which aims to strengthen the food safety system. The purpose of the strategy is to avoid fragmentation of the legislation and vague distribution of responsibilities among ministries, food control services and businessmen from the food sector. So, we will protect public health, prevent fraud and deception and facilitate trade. The population of the Republic of Moldova will receive information and education on food safety and

quality, and healthy diet as part of the national educational programs [4].

The accelerated reforms in the agri-food sector will contribute to the formation of new agricultural enterprises based on free association of small farmers; the functioning of the market economy mechanisms (competition, credit system, profitable investments); the modernization of techniques and technologies; the improvement of the legal framework for agriculture; the establishment of new mechanisms for agriculture financing and subsidizing; the degree of the rural economy diversification; inculcating the economic behaviour to farmers and developing the mentality flexible to various changes. All these would contribute to the formation of the efficient and competitive agriculture and its integration in the European markets.

Taking into consideration the modernization of agriculture and rural development we suggest:

- the organization of agriculture after the European agricultural model, based on some fundamental political and structural reforms, carried out by the public institutions competent in agriculture and food industry;
- the optimization of rural development policies: agriculture, fisheries, forestry, land reclamation, aquaculture, food production, land property consolidation, farm optimization and soil conservation;
- the development of the viable, competitive, modern agricultural sector that is able to ensure food security of the country and occupy the leading position in the regional agri-food market, producing food products in accordance with the highest standards;
- regaining the status of the net exporter of agricultural and food products by means of the constant increase in export supply thanks the increased yields and overall production of agricultural products;
- the development and diversification of economic activities in rural areas and the

increased employment rate through the development of small and medium enterprises, creating jobs and improving the life quality in rural areas;

- combating poverty in rural areas, access of the rural population to work, education and health services;
- preventing the population flee from rural areas and creating conditions for the investment in the rural economy, return, setting and employment of the people who have gone to work abroad.

## REFERENCES

- [1] Analiza pe țară, Națiunile Unite – Moldova, 2011. Disponibil la: [http://www.un.md/un\\_res\\_coord\\_sys/docs/Country%20Analysis%20-%20UN%20Moldova.rom.pdf](http://www.un.md/un_res_coord_sys/docs/Country%20Analysis%20-%20UN%20Moldova.rom.pdf), [Accesat la: 17 ianuarie 2014].
- [2] Anuarul Statistic al Republicii Moldova. Versiuni electronice. Disponibil la: <http://www.statistica.md/pageview.php?l=ro&idc>, [Accesat la: 10 martie 2014].
- [3] Bolganschi D., Migrația din mediul rural și utilizarea terenurilor în Republica Moldova, 2011. Disponibil la: <http://pdc.ceu.hu/archive/cps-research-report-rural-out-migration-moldova.pdf>, [Accesat la: 3 februarie 2014].
- [4] Hotărârea Guvernului cu privire la aprobarea Strategiei naționale de dezvoltare durabilă a complexului agroindustrial al Republicii Moldova pentru anii 2008-2015, Monitorul Oficial nr. 57-60 din 21.03.2008.
- [5] Mitrache, St., 2000, Dezvoltarea durabilă rurală. Editura Planeta, 89-91
- [6] Perju, I., Chivriga V., Fala, A., 2010, Impactul viitorului acord de liber schimb între Republica Moldova și Uniunea Europeană asupra sectorului agroalimentar din Republica Moldova. Chișinău: Ed.: Fundația Soros Moldova, 59-60.
- [7] Recensământul General Agricol, 2011, Republica Moldova. Rezultate principale. Biroul Național de Statistică al Republicii Moldova. 150 p.
- [8] Stratan, A., 2007, Evoluția economiei agriculturii Republicii Moldova: reflecții, probleme, mecanisme economice. Chișinău: Ed.: Tipografia AȘM, 185-196.
- [9] Strategia de gestionare integrată a deșeurilor solide, RDS. Disponibil la: [http://adrsud.md/public/files/Strategia\\_de\\_gestionare\\_a\\_deseurilor.pdf](http://adrsud.md/public/files/Strategia_de_gestionare_a_deseurilor.pdf), [Accesat la: 2 februarie 2015].
- [10] Zahiu, L., 2005, Politici și piețe agricole. București, Ed.: Ceres, 124-126.



## FINANCIAL MECHANISMS OF THE DEVELOPMENT OF THE AGRARIAN SECTOR IN THE REPUBLIC OF MOLDOVA

Aliona ȘARGO, Elena TIMOFTI

State Agrarian University of Moldova, 44 Mircesti St., MD - 2049, Chisinau, Republic of Moldova, phone: +373 767 15 222, Fax: (+373 22) 31-22-76, E-mail: e.timofti@uasm.md  
Phone: (+373)069232743; E-mail: alionasargo@yahoo.com

**Corresponding author:** alionasargo@yahoo.com

### Abstract

*This paper presents a research in the operation and development areas of the agricultural sector of Moldova. The mechanisms used to achieve the objectives of agricultural policies applied in the Republic of Moldova combine a set of specific agricultural tools and mechanisms traditionally applied in the developing countries. De facto, this combination of agricultural policy mechanisms directs important financial resources for transitory objectives fulfilled in order to promote a lasting development of the agricultural sector. The purpose of this paper is to investigate the structure of the financing mechanism of the agricultural sector in Moldova. The basic methods of the research is analysis and synthesis of the data of the Ministry of Agriculture, Agency for Interventions and Payments for Agriculture, Ministry of Finance, National Bank's and commercial Banks reports. With the signing of trade liberalization with the EU, local farmers begin to face strong competition with farmers from the European Union and will have to invest more in agricultural machinery and technology to achieve competitive production. This thing will be more difficult to achieve as long as loans to the agricultural sector in Moldova come mainly from two sources: commercial banks and non-bank financial institutions that are not accessible to all farmers.*

**Key words:** agricultural policy, banking, financial flows, financial institutions, funding mechanism

### INTRODUCTION

The financial mechanism is a part of the functional structure of the economic mechanism and shows the organization and circulation of financial flows and due to the mobilization, allocation and usage of financial funds are realised which are set up within the national economy. The functionality of the financial mechanism lies in its ability to provide technically the normal circulation of the financial flows without difficulties, and at the same time it allows and stimulates the economical activity carried out by economical agents regardless their form of ownership [6].

The financial mechanism is a functional component of the economic mechanism. Financial mechanism focuses on the adjusting processes, techniques and instruments of the financial activity which is reflected by operations and financial flows that take place in the context of economic and social activity as a whole. [8]

Agricultural enterprises and farms meet difficulties in their activity, and one of the

biggest obstacles that slows down the development of the agricultural sector is the lack of financial access. The financing of the agricultural sector ensures the cash flow that can be achieved with the own sources (self-financing), state budget subsidies, bank loans, repayable external funds granted by various projects and NGOs in the form of loans and microcredits, and external financing incentives granted in the form of grants, community support through various programs, etc.

In Moldova, agricultural financing is achieved mainly from the bank loans, the own sources of the agricultural enterprises and farms followed by state support in the form of grants, external grants and other sources.

### MATERIALS AND METHODS

Data of the Ministry of Agriculture, Agency for Interventions and Payments for Agriculture, Ministry of Finance, National Bank's financial reports, commercial banks and other financial and economic structures of the country and abroad were used as information sources in the analysis performed.

The basic methods of the research are analysis and synthesis, graphic and table method, economical comparison, time series method etc.

## RESULTS AND DISCUSSIONS

Agriculture is one of the most important branches in the Moldovan Agriculture, it is designed to contribute significantly to the renewed growth of our country. It is necessary to provide fundamental changes in the agricultural structure, material and technical equipment, the organization and re-organization of the agricultural enterprises that will guarantee a modern agriculture reported to the market economy. However, to ensure this modern agriculture special efforts are required to create a favorable investment climate, as the main source of the agricultural sector development. The macroeconomic context that favors the attractions of the investment, called "investment climate" is a very complex notion, determined by a mix of co-dependent elements which contain:

- lasting political and macro-economic stability;
- proper and non-discriminatory rules in the economic activity (the default investment);
- business development, including financial and judicial service, access to markets and resources (human, technological, etc.);
- transparency in the activity of state organizations regarding regulation and control, etc.

Table 1. Evaluation of the financial sources for investment in the agricultural sector of Moldova (in %)

Finding sources	Belarus	Georgia	Moldova	Ukraine	EU countries
Private sources	37.8	27.9	28.7	44.1	5
Commercial banks	23.1	23.5	26.5	28.5	22
Relatives and friends	12.8	12.8	12.7	10.1	-
Public institutions	11.5	10.1	13.8	10.1	15
International grants	3.8	11.7	11.7	10.6	8
National Financial Institutions	3.2	7.3	7.3	0	4
Other sources	7.7	6.7	6.7	3.4	-
Credit cooperatives in agricult	-	-	-	-	46

Source: [3]

Access to finance is essential for daily operations of agricultural enterprises, and even more, when it is necessary to use

investments in agriculture. According to a study conducted by EUROCHAMBRES about the primary sources of funding in Moldova, respondents rather use public funding schemes than from relatives and friends. [3]

Analyzing the rating we can notice that those who want to invest in agriculture of Moldova prefer to invest money obtained from different public or international institutions - 32.8%, which became available to farmers from Moldova, followed by own resources 28,7% accumulated mostly on account of remittances, unlike EU countries where 46% of sources are obtained from credit cooperatives in agriculture. This form of banking was launched in Europe in the nineteenth century by FW Raiffeisen. The model of the loan is currently available in all major European countries such as Austria, Belgium, Finland, France, Germany, Italy, Netherlands, Spain and Switzerland.

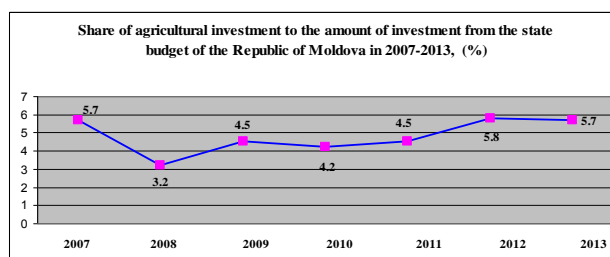

Fig.1. Share of agricultural investments to the amount of investment from the state budget of the Republic of Moldova in 2007-2013

Source: Own calculation in base source [4, 10, 11]

The results show that in 2007-2013 there were changes in the share of agricultural investments executed from the state budget of the Republic of Moldova. Thus, in 2008 this proportion decreased by 2.5 percentage points compared with 2007, followed by an increase of 1.3 percentage points in 2009, reaching 5.7% of the total state budget expenditures for 2013.

Also, the share of state budget expenditures for agriculture and forestry in 2010-2013 increased by 60.3%. The increase occurred mainly due to the increase in external sources of financing projects in the agricultural sector with 543.8 million. lei and special means with 45.7%.

Table 2. Performance of state budget expenditures for agriculture and forestry in Moldova

Name	2007	2008	2009	2010	2011	2012	2013
Agriculture and forestry (mln. lei), including:	820.3	516.7	830	843	829	1,254	1,360
Core components	797.9	492.0	612.0	614.2	613.1	702.8	730.9
Projects funded from external sources	-	45.6	76.2	191.0	180.1	510.4	589.4
Special sources	18.1	20.2	28.1	37.8	35.8	40.6	39.6

Source: Own calculation based on the source data[10]

Although the stock of FDI in 2013 amounted to 3,668.27 million. Euro increased with 6.4% compared to 2012, but the agricultural sector remains unattractive for FDI. This is partly because of the required long term investments and political and economic stability. The purpose of granting loans for agriculture is to provide long-term investments in modern equipment, irrigation equipment, building suitable breeding areas for animals growth, supplying with food and more, everything is designed to increase production. To investigate the lending of the agricultural sector we will analyze the information about the lending activity offered by the commercial banks in the country.

Table 3. Agricultural loans provided by commercial banks of the Republic of Moldova (2012-2013)

Granted credits for agriculture	Number of credits				The amount of money, mln. lei			
	2012		2013		2012		2013	
	lei	€	lei	€	lei	€	lei	€
Moldova Agroindbank	375	19	339	23	212.5	56.7	442.6	69.1
Banca de Economii	14	5	6	0	2,928	143.5	98.1	0
Victoriabank	22	27	20	3	24.1	196.4	37.3	79.5
Eximbank	21	2	38	2	169.7	14.8	2,706	106.9
Energbank	52	16	21	4	567.9	259.7	716.9	20.5
FinComBank	94	11	99	6	56	19.8	566.3	54.5

Source: [ 7]

Analyzing the data in the table above we can conclude that in 2013 only 1 banks increased their modest number of credits for agriculture - Eximbank-17 agreements. In general there is a tendency to reduce the number of conventions, but increased the amounts of credit. Thus, Moldova AgroindbankSA increased its agricultural loan amount with 230.156 lei and 149.056 lei Energbank SA in 2013 compared to 2012, but the amounts are too small compared to the needs of the sector. The most spectacular increase had Eximbank SA 2,536,452 lei during 1 year.

Although in the banking sector there is stiff competition for winning a bigger share of the

market, just few banks see this kind of business as a potential source of growth for their operations. Moldova-Agroindbank is the leader with 26.8% of total loans in lei, respectively, 23.2% of those in foreign currency followed by "Moldindconbank" SA (11%) and BC " ProCredit Bank "JSC (19%).

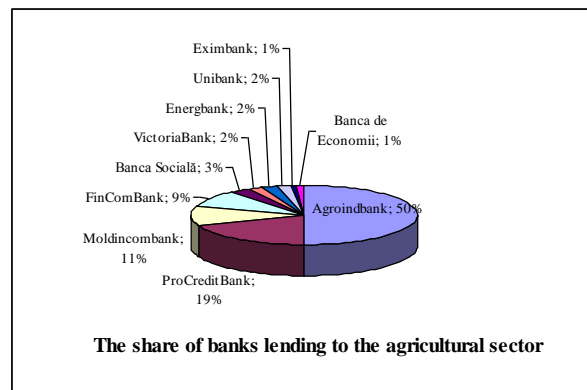

Fig.2. Share of correspondent banks in the credit AIPA MAIA and agriculture

Source: [2, 7, 12]

Income limits are relatively low in agriculture with changeable weather conditions, banks cover their additional risk with a generous margin added to reference indices. Thus, in terms of amount, maturity and currency identical credit for investment in agriculture would be about 2% higher than for the one investment in the industry. According to a study prepared under the National Economic Research Institute, about the trends in the national economy, Moldova is placed on the second position in the rating of the most expensive loans, number one is held by Georgia with 29%. In Romania a loan can be offered with an interest rate of 10% and 5% in Poland. This may explain why European countries, agricultural enterprises can expand their business by applying sophisticated technologies that not only increase the yield per hectare and allow the obtaining of the qualitative products, competent on the market, but also improve the working conditions of the farmers, thus leading to the growth of their standard of living.

## CONCLUSIONS

Lack of own financial resources is the primary problem for most local agricultural enterprises.

Loans to the agricultural sector in Moldova come mostly from two sources: commercial banks and non-bank financial institutions.

With the signing of trade liberalization with the EU, local farmers begin to face strong competition with farmers from the European Union and will need to comply with new requirements regarding business development in agriculture. At European level, in terms of technologies used in agriculture and current agricultural production, Moldova is far exceeded.

In order to industrialize the agricultural production and increase the share of raw materials processed it is necessary to equip the agricultural units with technical and modern equipment, but also changing the traditional methods of processing the earth and agricultural raw materials. This is not possible without considerable investment as investments are firing mechanism of all businesses.

## REFERENCES

- [1] Agriculture investment sourcebook, [www.worldbank.org](http://www.worldbank.org)
- [2] Date of Agency for Intervention and Payments for Agriculture (AIPA) form the Republic of Moldova <http://www.aipa.md/>
- [3] Doing business with the EU: an assessment of Eastern Partnership SMEs, [www.doingbusiness.org](http://www.doingbusiness.org)
- [4] National Strategy for Agricultural and Rural Development for the years 2014-2020
- [5] Românu, I., Vasilescu I., 1997, "Managementul investițiilor", Editura Mărgăritar, București
- [6] Reports of Moldova Agroindbank on loans to the agricultural sector <http://www.maib.md/ro/credite-agricultura/>
- [7] Reports of International Fund for Agricultural Development (IFAD), <http://www.ifad.md>
- [8] Reports of banks on loans to the agricultural sector [www.bank.md](http://www.bank.md)
- [9] Reports of National Bank of Moldova, [www.bnm.md](http://www.bnm.md)
- [10] Stratulat, O., 1998, Financial Mecanismul financiar, editura ASEM, Chișinău, 1998
- [11] State budget execution reports for the 2007- 2013 years, [www.mf.gov.md](http://www.mf.gov.md)
- [12] Ulian G., Finanțe publice, USM, Chișinău, 2007

## COMPARISON OF DEVELOPMENT EFFORTS MADE BY DIFFERENT AGENTS IN RURAL ANKARA: ANKARA DEVELOPMENT AGENCY CASE

Coşkun ŞEREFOĞLU, Gökhan YALÇIN

Ankara Development Agency, 1322. Cadde No: 11 Öveçler, Çankaya, Ankara – Turkey, +903123100300, Emails: cserefoglu@ankaraka.org.tr, gyalcin@ankaraka.org.tr

*Corresponding author:* gyalcin@ankaraka.org.tr

### Abstract

*This study mainly argues of OECD rural paradigm through the different types of grant mechanisms carried out in rural Ankara. In general terms, the main aim of this study is to examine profoundly the support mechanisms that are conducted by four public agents for development of rural areas, which are classified according to the OECD definition, in last decade and specifically analyse the activities of Ankara Development Agency in comparison with old approaches and grants as a case study. Of the grants, the Agriculture and Rural Development Support Institute, which is funded by EU, is the one who granted more than TL 200,000,000 of which more than 89 % has been used for investment into agricultural holdings in Ankara since 2011. The projects of Special Provincial Administration and the Provincial Directorate of Food, Agriculture and Livestock are basically infrastructure in villages and agro-based industries, respectively. The type of support given by Ankara Development Agency when compared with others becomes considerably dissimilar. Not only does Ankara Development Agency carries out economic programmes in rural areas but it also conducts some social development programmes as well as technical assistance covering training and consultancy service and direct activity support for strategic research, planning and feasibility studies. Ankara Development Agency has supported a significant number of projects for a total budget of TL 12,019,664 in reducing intra-regional differences in terms of development during 2010-2014. Accordingly, around 22 % of the subsidized projects under the direct financial support made by Ankara Development Agency have been implemented in rural parts of Ankara since its establishment in 2010. Similarly, approximately 25 % of the direct activity support and technical support has been used by agents whom settled in rural areas. It is concluded that there is a spectacular progress in rural areas through the projects and implementations made by Ankara Development Agency in the short run and the tacit knowledge and local dynamics of rural areas in Ankara will be successfully revealed with concerted efforts of related agents in the long run.*

*Key words:* agricultural development, Ankara development agency, development agencies, rural areas development

### INTRODUCTION

Rural areas in literature raise two important interdependent questions due to the remoteness. One of which is a continuous rural depopulation, the other is a severe poverty due to lack of human capital and technology and natural endowment. It is highlighted by IFAD [7] that 55 per cent of the total population live in rural areas and poverty in those areas is more common than urban areas. Rural areas in Turkey have rapidly been shifting in the last decade driven by a range of socio-economic, political and environmental factors. This study aims to find out the impact of grant mechanism by analysing different agents' approaches with secondary data provided by related agents

concerning rural areas' development.

According to the data provided by TURKSTAT, the share of agriculture in GDP and civilian employment in Agriculture are more than 20 %. This obviously shows that the role of agriculture in economy is still important for Turkey on contrary to developed world. The same values for Ankara were found roughly 2.6 % and 5 %, respectively. This has been argued by Johnston and Mellor [7] that agriculture's contribution to the specifications for development capital is particularly important in the earlier stages of the process of growth. A similar view is held by Oskam and Whitteloostuijn [14]. They stressed that the

relative economic importance of agriculture in developed countries are decreasing in spite of the fact that agriculture is not an isolated part of the economy. As argued by Tsarouhas [16], traditional models based on top-down approach were not able to meet the requirements because of high degree of interdependencies of central and local administrations. Therefore, bottom-up approaches have been mostly preferred to top-down approaches. Supporting the activities for rural and local development has been indicated under responsibility of development agencies by Yaman and Kara [19].

It has been found that more than 82 % of the funds in rural areas have been provided by Agriculture and Rural Development Support Institute (ARDSI). The share of Ankara Development Agency, Special Provincial Administration and Provincial Directorate of Food, Agriculture and Livestock is in turn 5,4%, 5,7% and 6,9%. The rural policies which are supported with statistics show that the integrated approach used by Ankara Development Agency is in line with OECD rural paradigm and more inclusive although it has very limited budget when compared with other agents.

This paper is outlined in four main parts. First the emergence of bottom-up policies in rural development will be outlined briefly together with the essence of rural areas concerning development. Following on, a short story of evolution of agriculture sector in Ankara Region will be given in the third section. Finally, significance in subsidies of ADA in comparison with other public institutions will be presented in order to propose the well-fitting structure of ADA's policies in new rural paradigm whereas others still follow a more conventional way.

## **MATERIALS AND METHODS**

### **Emergence of Bottom-Up Policies in Rural Development**

Top-down approaches, which have been highly adopted and more likely failingly implemented by many countries in history, have significantly lost their extreme importance in economic development.

Instead, as stated by Halkier [5], bottom-up approaches have become a prominent role to promote economic development through regions. As a failure of top-down approaches, the population in rural areas has dramatically decreased due to the lack of investment, mismanagement and an insufficient physical infrastructure. Rural areas in developing countries, analyzed by Lipton [10], showed that income per person inefficiencies and inequities has resulted in urban areas` favor. So, Regional Development Agency-type organizations in the European Union has become main drivers of underdeveloped regions as well as developed ones. In this context, strengthening indigenous growth, improving economic software, semi-autonomous regions, and regional designation through decentralization of policy administration have become main features of a bottom-up approach [5]. A similar approach which was developed by OECD is the new rural/regional paradigm that aims to reshape rural regions. It is believed that rural regions can make a significant contribution to economic growth, with a narrow interest group, by changing the main structure of system of national subsidies [13]. As is seen in Table 1, rural areas are not solely composed of agricultural activities which have diminishing returns. Instead, diversification of economic activities through tourism and innovative approaches targeting competitiveness as well as making various local actors get involved in local policies.

Within this context role of development agencies in delivering bottom-up policies under the rationale of governance paradigm becomes crucial in development policies as well as rural. Increasing inequalities within/among regions with respect to economic development are seriously considered by policy makers. Kessides [9] and Eraydin [2], draw attention to first generation sense of regional development in 1970`s. According to Kessides [9], the main failure of rural development programmes was the approach to aim to do everything in the region at the same time. A similar stance was taken by Goldenberg [4]. He showed that incentives such as grants, loans and tax deduction in

traditional approach have generally tended to be given for increasing the competitiveness of local economies through supporting job activities, facilitating access to capital and pursuing initiatives to increase investment in the targeted regions. It has been suggested that simply providing incentives in regional development has the least impact and nothing but excessive wastage [19]

Table 1 - The New Rural Paradigm

	<b>Old approach</b>	<b>New approach</b>
<b>Objectives</b>	Equalisation, farm income, farm competitiveness	Competitiveness of rural areas, valorisation of local assets, exploitation of unused resources
<b>Key target sector</b>	Agriculture	Various sectors of rural economies. ex. rural tourism, manufacturing, ICT industry, etc.
<b>Main tools</b>	Subsidies	Investments
<b>Key actors</b>	National governments, farmers	All levels of government (supra-national, national, regional and local), various local stake holders (public, private, NGOs)

Source: OECD, 2006

This limited effect of the programmes shifted the main approach to “development guided by communities” in 1980`s. The new approach for economic development has predominantly focused on space and mobilizes the local powers in order to increase the level of welfare of the regions. Yaman, Derviş, and Kindap [19] highlighted that the main identifier for success is laid on a synergy, cooperation, coordination, governance, institutionalization, strategic management, common sense and human capital. In the last two decades, innovation-based approach to promoting rural development have predominantly adopted by developed counties such as Canada and Western Europe.

As highlighted by Goldenberg [8] inclusiveness is the most important part of new regional development paradigm. A similar view is held by Dinler [1]. He

emphasized the importance of participation of local people on the preparation and implementation of regional programmes and sees it as a must for success. In the same direction, European Union has implemented very successful rural development programmes under objective 5 of structural funds. Two main instruments were basically used by the European Agricultural Guidance and Guarantee Fund (EAGGF). One of which was a specific support for agricultural and forestry activities and the other one was diversification away from traditional activity. Tsarouhas [16] underlined that good governance at local level is not only for decreasing intra-regional disparities but it has also a vital role for sustainable development at national level.

**The Essence of Rural Areas Concerning Development**

Three crucial features of rural areas are underlined by Wiggins and Proctor [17]. The first one is the relative abundance of land since it is relatively cheap in rural areas. The second is significant distance between rural settlements and urban areas. It might be costly to move goods from rural areas to urban areas where they are mostly consumed and marketed. Last one is the poverty of rural settlements. Rural regions are generally characterized as the most disadvantages areas in the literature. If analysed the structure of rural areas, it can be clearly seen that those areas have many disadvantages as well as some advantages. The most important problem of rural areas is the physical infrastructure such as transport and communication networks which connect rural areas to urban nodes where innovation, technology and financial institutions exist. It has been underlined by OECD [12] that the new conditions of lifestyle such as rural idly and environmental quality replaced the old conditions referring to the experience of rurality by farmers and labours working in the industry.

Rural areas have a relatively large but shrinking agricultural sector if compared with urban areas [16]. As expressed by Goldenberg [4] there is a strong relationship between rural and urban areas. Rural areas should not only

be seen for economic activities based on agriculture which is not an isolated part of the economy [14]. They have also important roles for urban growth and available green space and recreational opportunities. Stated in other words, urban areas create new markets for rural goods as well as financial and cultural supports. According to Freshwater [3], there are three main constraints on Turkish agriculture. Firstly, there are weak institutions which cover fragmented land holdings and weak management skills. Secondly, there is a notably difficulty to access to capital and insufficiently developed land tenure systems creates the third constraint. Oskam and Whitteloostuijn [14] highlighted that one of the essential concepts in determining the contribution of agricultural activities or agricultural based industries to society is its value added. Increasing value added is totally depending on a very strong cooperation among interest groups. Therefore, creating an integrating development strategy together with other agents in region is quite important, albeit notoriously difficult, for regional development agencies. On the contrary to central planning, regional development agencies prepare regional plans in collaboration with the local actors. A study implemented by Terluin and Post [15] suggests that differentials in employment growth among rural regions seem to be related to the degree of mobilisation and organisation of local actors. It has been stated by OECD [12] that local actors such as local policy makers and entrepreneurs under normal circumstances do not have a capacity to develop new ideas for their areas. Hence, development agencies are desperately needed to provide the required encouragement and source of mobilization for those.

As illustrated by O'Connor (2006) in Figure 1 below, apart from traditional agricultural activities inserted in inner triangle, the structure of rural development requires a mutual coordination of activities between three dimensions. In and through rural development and deepened agricultural activities, diversification of economic activities such as rural tourism, the management of nature and landscape and the

development of new on-farm activities would be possible to implement. Development Agencies particularly support agro-tourism and nature and landscape management and also specific activities aiming to increase the competitiveness as well as off-farm income. It would not be totally wrong to say that no activities belonging conventional agriculture would be in a certain extent supported by development agencies. Instead, the Ministry of Agriculture still continues to support primary products with its incentives.

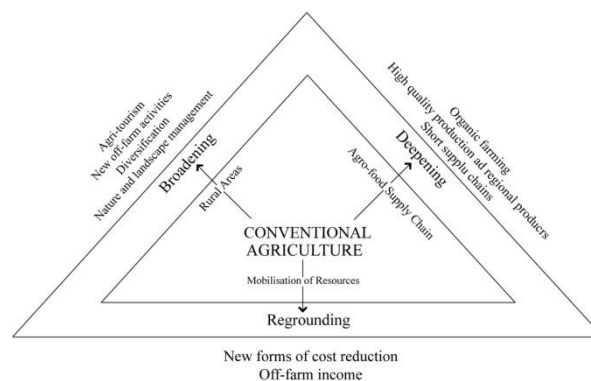

Fig.1. The Structure of Rural Development at Farm Enterprise Level  
 Source: [11]

## RESULTS AND DISCUSSIONS

### Evolution of Agriculture and Rural Sector in Ankara Economy

15 out of 25 districts of Ankara are located far away from central part of Ankara. Population density in rural part of Ankara is remarkably low, and their agricultural labour force represents only a very small proportion of total civilian employment of Ankara province as a result of a massive migration from rural areas to urban areas since 1980's. Also, a shrinking working age population, ageing, low fertility rate, high crude mortality rate and continuously increasing negative net migration in rural areas have basic repercussions for education, health and infrastructure, the economy and the labour market, and public finance. The rural shares of total population in Turkey and Ankara account for 22.7 % and 0,002 % in 2012, respectively (TURKSTAT). Although the importance of rural population is statistically less likely important, ADA decisively



continues its pervasive policies in all countryside. Table 2 shows that the share of agriculture in total value added has been declining throughout the period in almost all countries but in Turkey agriculture had a significant contribution to total value added. In contrary to situation of Turkey's average values, the contribution of agriculture to Ankara's economy accounts for 2.59 in 2010 (TURKSTAT). This respectively gives similar results with other OECD countries.

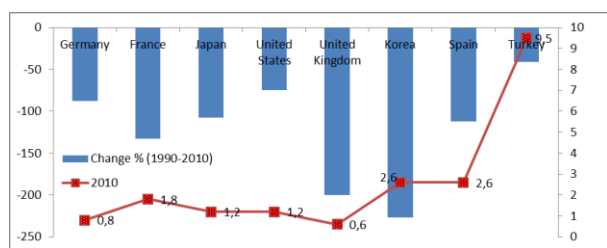

Fig. 2. Share of value added in Agriculture (%)  
 Source: OECD Database, 2012

Agriculture's contribution to employment in percentage terms is given in Fig. 3. The change of employment in agriculture from 2004 to 2012 has shown a continuous decrease in all countries including Turkey but United Kingdom. Although Turkey has experienced the same decline in the employment, its rate is still far higher than other OECD countries. As for Ankara, the agriculture's contribution to employment is approximately 5 % which is again not too different from OECD countries.

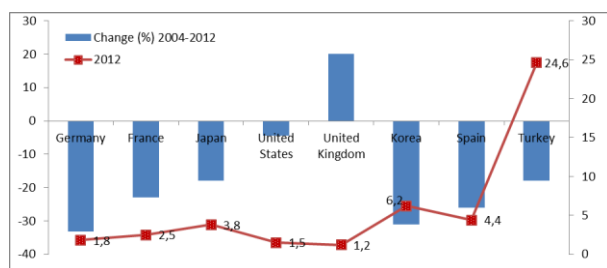

Fig. 3. Agriculture's contribution to employment (%)  
 Source: OECD Database, 2014

The data drawn from TURKSTAT clearly points out that the rural part of Ankara has made a considerable move with industrialization. This is in line with Terluin and Post [15]. They suggested that increasing competition in urban areas might put a strong pressure on rural areas to reorganize their

economy by promoting continuous innovation and improving social and human capital. It, however, cannot be concluded that all rural areas have the same development patterns. Although some districts of Ankara have managed to cope with new economic challenges and succeeded in transforming their economic structure some other have failed to do so and experienced shrinkage in their population and decrease in overall economic activities.

According to the OECD definition for rural areas, only a small part of Ankara shows predominantly rural character as it is given in Fig.4. Due to figures of 2012, Ankara as a province shows intermediate/significantly rural areas. Predominantly rural areas and intermediate/significantly rural areas account for 1.9 % and 3.3 %, respectively. Wholly urban areas dominantly consist of 88.4 %. Seemingly, the population of Ankara would prefer to settle in wholly urban areas.

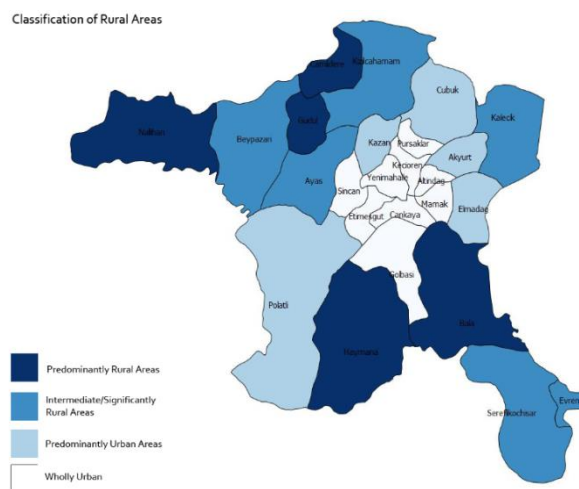

Fig.4. Classification of Rural Areas in Ankara Province  
 Source: [12], Classification made by authors

Rural areas of Ankara show greatly differences in term of the social and economic problems faced. Some of the districts are very lagging behind of development. It can be seen that agriculture based industries have not sufficiently developed. In most rural areas, as it has been stated by Hill [6] agriculture has no major role in rural areas. Jonston and Mellor [8] concur with this view. They stressed that small scaled farmers encounter considerable difficulty in maintaining

efficiency due to the lack of institutional capacity of local agents which creates serious problems and impedes to make a remarkable

progress in Agriculture.

Correspondingly two important points are marked in Fig.5.

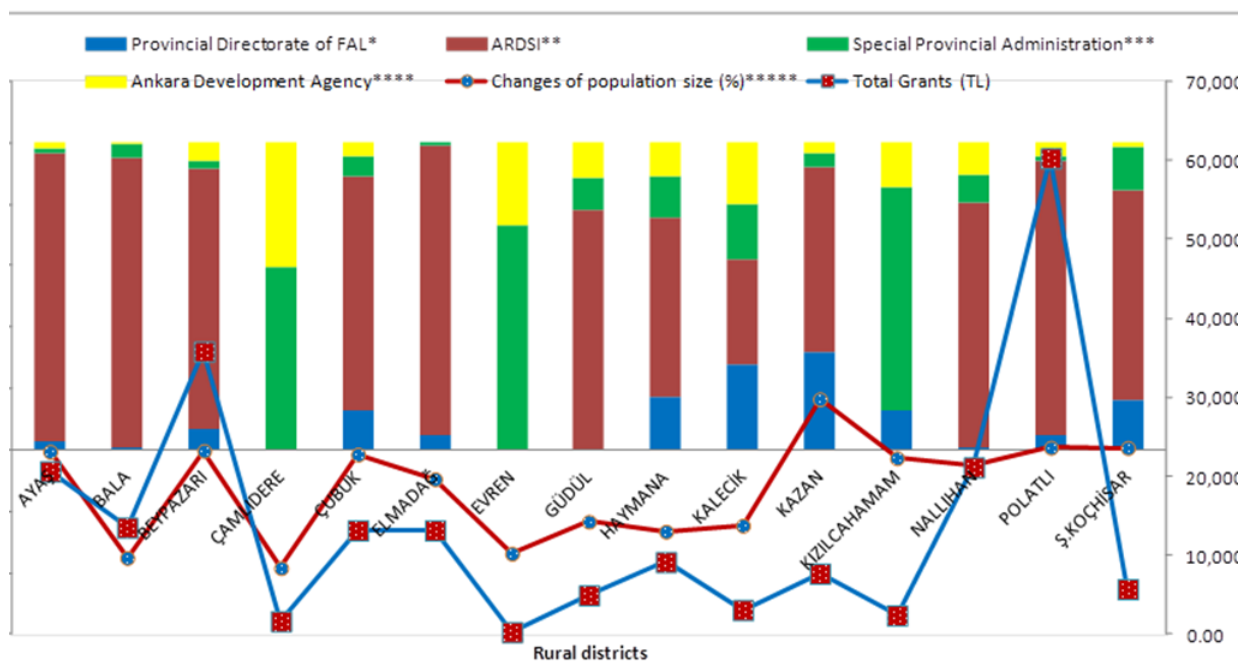

\*2006-2014;\*\*2012-2014;\*\*\*2004-2012;\*\*\*\*2010-2014;\*\*\*\*\*2007-2012

Fig.5. Grant distribution of public institutions

One of them is the distribution of grants delivered by public agents and the other is the population size of the rural areas in Ankara. As is clearly seen from table, Agriculture and Rural Development Support Institute (ARDSI) has funded in a large number of projects with much higher budgets despite of the fact that the agent was just accredited by EU a few years ago. Yet, it appears that the demand for diversification of economic activities is not high enough in rural areas. Only less than 5 % of funds were used for it. Furthermore, more than 95 % of them were used just for purchasing tractor. Correlatively, more than 89 % of grants directly went to investment into Agricultural holdings while only 6 % was used for processing and marketing of milk and meat industries. Also, it can be said that ARDSI funds have not been actively used by remote rural areas such as Camlidere, Evren and Kizilcahamam districts. The provincial directorate of Food,

Agriculture and Livestock is not standing in a different place from ARDSI. Special Provincial Administration, which was shut down in 2013, seems to have made great contribution for rural remote areas in terms of infrastructure. Lastly, Ankara Development Agency that aims an integrated development in the region supported almost all remote rural areas. What differentiates Ankara Development Agency from other agents is the support mechanism. Complementarity has an essential element for Agency. Rather than solely financing economic investments, Ankara Development Agency mostly adopt OECD rural paradigm which aims to exploit new unused resources in rural areas. Although the allocated grant is relatively smaller than other agents, the value added of the projects that Ankara Development Agency supports seems much higher than other grants. The change of population size explains to some extent whether the grants have any impact for

stabilising the rural migration.

### **The Policy Suggestions Brought By Ankara Development Agency**

ADA aims to improve the overall environment of rural areas and make them liveable places where people feel safer themselves and where young people can build their future in those areas through the financial support programmes it organizes. These programmes are basically grouped in two main activities not excluding environmental activities. These are economic development and social development. For both, an integrated approach covering all related institutions is very important for more effective development projects including roads, electricity, water supply and renewable energy, environment and social inclusion. After the unions of village delivery services were shut down with the decree of metropolitan municipality, a new unit which is called rural services was set up by Ankara metropolitan municipality. The physical infrastructure are thus planned and implemented by Ankara metropolitan municipality. ADA which is in close cooperation with Ankara metropolitan municipality and Agriculture and Rural Development Support Office of Ankara and also district directorates of Food, Agriculture and Livestock organize regular meetings in districts and get reliable feedbacks from local actors for a better district development. Another important issue for districts is to access safely to education, health care and financial services and communication and information services. Some of the schools located in the districts have benefited from grants given by ADA. The modern technical equipment for schools would be eligible investment type under the grant programmes. Also, the most disadvantaged groups which consist of women and young have the priority for the financial support programme run by ADA. Comprehensive district road maps for rural districts of Ankara are fundamentally driven by a coalition of local stakeholders under the lead position of ADA. The whole picture of the districts including main problems and opportunities are drawn through these studies. ADA plays an important

guiding role so that it can get accurate reports from service providers. So, for each report/feasibility study, an expert from planning department of ADA is allocated to monitor and effectively evaluate it.

Innovative solutions for agricultural production and diversification of economic activities such as rural tourism and off-farm products as well as agro-environmental measures such as conservation of high-value added countryside not excluding climate change seem key determinants of sustainable development for rural areas in Ankara. In this sense, ADA prioritizes of improving capacity of local people to establish and sustain development within the region. Improving knowledge and skills and changing attitude are the principal instruments which are supported by technical assistance implemented by the Agency. Never have rural areas been ignored by regional policies in spite of the fact that Ankara is a province of which competitiveness is likely much higher than other regions. On the contrary, more importantly, the innovative potential and tacit knowledge of predominantly rural areas are deeply analysed with powerful feasibility and sectoral analysis studies. Also, the institutional capacity of stakeholders such as development cooperatives, as well as public agents is paramount importance for development efforts held by agency.

### **CONCLUSIONS**

The grants delivered by different agents for rural Ankara show that significant number of projects were supported by those who aim to increase the competitiveness of rural areas. Most of the districts of Ankara could be classified as remote rural areas which have important infrastructure and marketing problems. Diversification of economic activities are particularly supported by two different agents, one of which ARDSI, the other one is Ankara Development Agency. Unfortunately, only 0.2 % of the grants provided by ARDSI go to it. At this point, ADA to a certain extent remarkably differentiates with its supports, which are structurally dissimilar with other grants. ADA

wants to achieve to mobilise the community to play a more active part in local area's development and foster truly integrated development as well as to foster innovative projects in parallel with creating a culture of enterprise. It has been found that around 22 % of total grants under the direct financial support were used for rural Ankara, and more importantly, roughly 25 % of direct activity support and technical support, which aims to exploit the unused resources including human capital, were transferred to rural areas, which have very significant impacts in rural areas. Moreover as also stated above, it is not the only policy option of ADA to give subsidies or grants to rural development projects in districts, but instead ADA tries to create a capacity in those remote areas in order to make them capable to sustain the further projects. Participatory planning approach in district road maps is only an example of this mentality. This is all to say that, in line with rural paradigm of OECD, rural development perspective of ADA is not limited with farm competitiveness and directing subsidies only to agricultural sector but instead it aims to make use of local assets and idle resources through mobilizing all levels of government and diversify economic activities such as rural tourism and agro-industries. Furthermore, increasing local capacity in the long run through the activities mentioned above will turn into an advantage of peripheral areas.

## REFERENCES

- [1]Dinler, Z., 2010, Cumhuriyetimizin Kurulusundan Gunumuze Izlenen Bolgesel Kalkinma Politikaları ve Kalkinma Ajansları. Türkiye`de Bolgesel Kalkinmanın Yeni Orgutleri: Kalkinma Ajansları. pp.53-66.
- [2]Eraydın, A., 2010, Bölgesel Kalkınmanın Yönetişim Çerçevesinde Kurumsallaşması: Kalkınma Ajansları. Bölgesel Kalkınma Ajansları. pp. 9-30.
- [3]Freshwater, D., 2012, Using OECD Regional and Rural Analysis to help inform Regional Development in Turkey. TEPAV 7th Regional and Governance Symposium, Ankara, Turkey.
- [4]Goldenberg, M., 2008, A Review of Rural and Regional Development Policies and Programs. Canadian Policy Research Network.
- [5]Halkier, H., 2011, Regional Development Agencies: European Trends and Experiences. The Proceedings of

- 1st International Conference On Regional Development. 22-23 September 2011, Malatya, pp. 1-19.
- [6]Hill, B., 2005, The New Ural Economy. Change, Dynamism and Government Policy. London, p.91.
- [7]IFAD, 2011, Rural Poverty Report. Overview. International Fund for Agricultural Development.
- [8]Johnston, B., Mellor, J., 1961, The Role of Agriculture in Economic Development. The American Economic Review, Vol. 51, No. 4 (Sep., 1961), pp. 566-593.
- [9]Kessdies, C., 2008, Dengeli Kalkınmanın Tabandan Yukarı Doğru Harekete Gecirilmesi: 2009 Dünya Kalkınma Raporu'na Dayanan Bir Yerel Kalkınma Perspektifi. Yerel Kalkınma Yönetişimi Uluslararası Konferansı, 24-25 Ekim 2008, İstanbul Politikalar Merkezi, İstanbul, pp. 9-18.
- [10]Lipton, M. (1981). Why poor people stay poor. Rural Development, theories of peasant economy and agrarian change. pp. 66-82.
- [11]O'Connor, D. Driving Rural Development: Policy and Practice in Seven EU Countries. Uitgeverij Van Gorcum, 2006.
- [12]Organisation for Economic Co-operation and Development, 1993, What future for our countryside? A rural development policy. Paris.
- [13]Organisation for Economic Co-operation and Development, 2006, The New Rural Paradigm, Policies and Governance. Paris.
- [14]Oskam, A., Witteloostuijn, A.V., 2010, Agriculture and the food chain. EU policy for agriculture, food and rural areas. CABI Publishing, Wallingford, Oxon. pp. 149-164.
- [15]Terluin, I.J., Post, J.H., 2010, Economics Dynamics in rural Europe. EU policy for agriculture, food and rural areas. CABI Publishing, Wallingford, Oxon. pp. 309-322.
- [16]Tsarouhas, U., 2008, AB Perspektifinde Yerel Yönetişim: İlkeler, Beklentiler ve Tecrübeler. Yerel Kalkınma Yönetişimi Uluslararası Konferansı, 24-25 Ekim 2008, İstanbul Politikalar Merkezi, İstanbul, p.p. 19-24.
- [17]Wiggins, S., Proctor, S., 2001, How Special Are Rural Areas?The Economic Implications of Location for Rural Development. Overseas Development Institute. USA.
- [18]Yaman, A., Kara, M., 2010, Türkiye'de Bölgesel Gelişme Politikasının Dönüşümü Sürecinde Kalkınma Ajanslarının Kuruluş Çalışmaları: Son Durum ve Değerlendirmeler. Bölgesel Kalkınmanın Yönetişim Çerçevesinde Kurumsallaşması: Kalkınma Ajansları. Bölgesel Kalkınma Ajansları. pp. 31-60.
- [19]Yaman, A., Derviş, Z., Kindap, A., 2008, Yerel ve Bölgesel Kalkınmanın Kurumsal Altyapısının Oluşturmada Kalkınma Ajanslarının Rolü. Yerel Kalkınma Yönetişimi Uluslararası Konferansı, 24-25 Ekim 2008, İstanbul Politikalar Merkezi, İstanbul, p.p. 56-97.

## PRACTICAL ASPECTS RELATED TO THE ACCOUNTING OF FOREIGN CURRENCY MARKETING IN THE LICENSED BANKS OF THE REPUBLIC OF MOLDOVA

Tatiana ȘEVCIUC, Veronica PRISĂCARU

The State Agrarian University of Moldova, 44, Mircești Street, MD-2049, Chișinău, The Republic of Moldova, Phone: + 37322432815. E-mail: sevciuctatiana@mail.ru, v.prisacaru@uasm.md

*Corresponding author:* sevciuctatiana@mail.ru

### Abstract

*Commercial banks perform operations on the currency market in order to buy a certain amount of currency that is necessary in their currency activities with clients, to receive speculative earnings as a result of currency purchase-sale transactions, as well as to cover the risks that appear in currency exchange fluctuations. This article evaluates the peculiarities of the accounting of foreign currency sale and purchase through transfer and in cash. The article also pays special attention to the ways of starting and managing of currency accounts in licensed banks and to the foreign exchange offices organization and functioning in the Republic of Moldova.*

**Key words:** accounting, foreign currency, foreign exchange offices, licensed banks

### INTRODUCTION

In accordance with the conditions of the point 115 Regulation on the terms and conditions of foreign exchange transactions from January 28, 2010 (Regulation on the terms and conditions of foreign exchange transactions, 2010) [4] purchase operations of foreign currency against national currency by legal resident entities is carried out by licensed banks and is based on documents that are established during the transaction, the amount and other terms agreed by the parties.

The purpose of this research is to highlight the peculiarities sale and purchase of foreign currency by authorized banks in Moldova.

### MATERIALS AND METHODS

Research has been conducted using a monographic study. The laws pertaining to the regulation and conduct of foreign exchange operations in Moldova are regulated by the legislation drafted by the National Bank of Moldova, including the Foreign Exchange Regulation Act (Law on Foreign Exchange Regulation, 2008) [3], on the terms and conditions of foreign exchange operations (Regulation on the terms and conditions of

foreign exchange transactions, 2010) [4], and the regulation on units exchange (Regulation on Foreign Exchange Entities, 2009) [5]. The study in question evaluated accounting for the sale and purchase of foreign currency in cash and non-cash. Also special attention was paid to the ways of opening and managing forex accounts with licensed banks, and the organization and functioning of the foreign exchange offices of the Republic of Moldova.

### RESULTS AND DISCUSSIONS

For transactions in foreign currency, commercial banks opened the accounts of "Nostro" and "Loro". The "Nostro" account is an open bank account in another bank and is registered in a foreign currency as account **1032 „Nostro’ account in banks.”** The "Loro" account is another open bank account that takes on the name of **„2032 ,Loro’ accounts in banks.”** The collection of funds in the foreign currency account is debited to **1032 „Nostro’ account”** and it credits the **2224 „the current accounts of legal entities,”** and their passage and decrease is debited in the account **2224 „The current accounts of legal entities”** and credit the **1032 „Nostro account.”**

Commercial banks perform transactions of the currency market by buying a certain amount of foreign currency necessary for their work with clients, accumulating income from speculative transactions of the purchase and sale of currencies, and hedging foreign exchange fluctuation.

A difference exists between the buying and selling of currency. This difference is known as the margin, and it allows banks to profit. The main rule in determining the course of sale is that banks buy a certain currency at a rate lower and sell the same currency at a rate higher, at different times, gained from price difference gain. This activity is called currency speculation (Grigoriță, 2005) [2].

Foreign exchange transactions are conducted between commercial banks and between banks and their customers. There are two types of transactions in the FOREX market: the short and long term. Spot transactions are the sale and purchase of currency ends on the same day (or within 48 hours maximum); so that the transaction coincides with the formation of the exchange rate of the day. Term operations (forward) are those in which the time of the transaction is separated at the time of its execution, and the delivery and payment currency is carried out over several months at a time agreed between the parties. The characteristic of this transaction is at the time the transaction occurs in course of the day, which is different from the exchange rate at the date of transaction. Of course the difference between the two time points results in advantages or disadvantages for trade partners (Grigoriță, 2005) [2].

Commercial banks can perform sale and purchase of foreign currency in two ways, by bank transfer (non-cash) or cash.

Bank transfer foreign exchange transactions are conducted at the request of customers or by direct negotiations. Foreign exchange transactions are a sum in a certain currency against payment in another currency at a rate set at the time and date of the transaction.

Non-cash foreign exchange transactions for clients are currently provided by all banks in the Republic of Moldova, the conditions offered are virtually identical, but (depending on the capabilities and resources) may vary

during the transaction (usually, most banks do not receive commission, but the exchange difference operations purchase - sale).

In order to maintain currency stability and prevent speculative transfer of capital from the Republic of Moldova, the National Bank of Moldova sets restrictions on foreign currency transactions. According to the regulation on foreign exchange in the territory of the Republic of Moldova, the following restrictions are as follows:

-Legal resident entities are entitled to purchase foreign currency only when this is necessary prerequisites payments regulation.

-Individuals can carry out exchange operations at the rate set by the bank and by the terms and conditions established by the internal rules of the bank. Typically, individuals engage foreign exchange through exchange offices (Regulation on the terms and conditions of foreign exchange transactions, 2010) [4].

According to the regulation rules, legal resident entities are required to use foreign currency purchased within seven days. If this currency is not used as intended by the deadline, businesses are required to forward to the sale against MDL authorized banks (Regulation on the terms and conditions of foreign exchange transactions, 2010) [4].

Banks set themselves the buying and selling rates of foreign currency transactions with businesses. At the same time, these rates may be set unique for all customers, as well as individually for each client.

The accounts in foreign currency are kept in the same synthetic accounts as the accounts in national currency. Analytical evidence is organized under personal accounts by the type of currency and the account holders. The personal account numbering is indicated by currency code. International or internal codes may be used (eg international code is USD 843).

Transactions in foreign currency are reflected in the official record set by BNM. This occurs as the change in the revaluation of the account balances are carried out. Revaluation is reflected in account **4655 "Profit / loss from revaluation of foreign currency."**

Following the transactions of sale of foreign

currency, the bank can earn a profit or lose it and this is determined by the difference between the official BNM and authorized by the bank. The exchange difference is reflected in account 4654 "Profit/loss from the sale of foreign currency." The account's credit records the revenue and losses.

The accounting entry for buying foreign currency by the client is:

- Debit account 2224 „Current accounts of legal entities" (account in national currency),
- Credit account 2224 „Current accounts of legal entities" (account in foreign currency),
- Debit/Credit account 4654 „Profit/loss from the sale of foreign currency" – the difference between the official and the authorized rates.

For example, the client bought USD 1,000 dollars. The official rate is Lei 10.2 per one dollar, and the authorized selling rate is Lei 10.25 per one dollar.

The transaction of sale of foreign currency is reflected in the accounts as follows:

- Debit account 2224 "Current accounts of legal entities" - Lei 10,250,
- Credit account 2224 "Current accounts of legal entities" - \$ 1,000 - Lei 10,200,
- Credit account 4654 „Profit/loss from the sale of foreign currency" – Lei 50.

The accounting entry of the sale of foreign currency by the client is:

- Debit the account 2224 „Current accounts of legal entities" (account in foreign currency),
- Credit the account 2224 „Current accounts of legal entities" (account in national currency),
- Debit/Credit the account 4654 „Profit/loss from the sale of foreign currency" – the difference between the official and the authorized rates.

For example, the client sold USD 1,000. The official rate is Lei 10.2 per one USD, and the authorized rate of buying is Lei 10.10 per USD.

The purchase of foreign currency by the bank is reflected in the accounts as follows:

- Debit account 2224 „Current accounts of legal entities" – \$ 1,000 - Lei 10,200,
- Credit account 2224 „Current accounts of legal entities" – Lei 10,100,

- Credit account 4654 „Gain/loss from the sale of foreign currency"– Lei 100,

And if the purchasing rate would be Lei 10.40 for one USD, then:

- Debit account 2224 „Current accounts of legal entities" – \$ 1,000 - Lei 10,200,
- Debit account 4654 „Profit/loss from the slae of foreign currency"– Lei 200,
- Credit account 2224 „Current accounts of legal entities" – Lei 10,400.

Authorized banks that open the currency exchange are required to apply for registration at each National Bank (Regulation on Foreign Exchange Entities, 2009) [5].

Legal entities may purchase foreign currency only if it is necessary to carry out foreign payments and the reimbursement foreign currency loans granted by commercial banks of Moldova.

The exchange office may conduct activities only in accordance with the authorization granted by the National Bank of Moldova.

Exchange offices are entitled to perform the following operations:

- Foreign currency purchasing transactions in cash currency and traveler's checks for individuals at their own expense;
- Foreign currency sale transactions in cash and traveler's checks for individuals at their own expense;
- Cash foreign exchange operations in another currency;
- Exchange transactions by cards;

Purchasing transactions of foreign currency from individuals are made at the exchange rate of purchase for individuals on the day that they perform the transactions. Foreign currency sale transactions are carried out in the course of individuals selling to individuals on the day of performing the transactions.

The authorized bank fixes or stablizes the exchange rate of the purchase and sale of foreign currency for individuals. At the same time, the difference between the purchase rate and selling rate is the bank fee. The exchange office may charge a fee for transactions set by the management of the bank through a provision. The list of tariffs and rates established are accessible to customers.

The purchasing and selling rate is fixed daily

by an order signed by the head of the bank and authenticated by the stamp of the bank. Every day except for weekends, until 12 o'clock in the morning the commercial bank is obliged to inform the National Bank of Moldova on their rates. The authorized banks may have the same rate of buying and selling for all exchange offices or a different rate for each branch, depending on the supply and demand of each branch.

The exchange office has no right to change the rates during the work day after the purchase and sale rate is set.

The movement of cash in the currency exchange house is reflected in account **1003 "cash in the currency exchange house in the bank."** In the debit account, it records the collection of funds in foreign currency, and credit - their value decreases. The supply of the foreign exchange house occurs in the transactions office. In this case, it prepares accounting records.

- Debit account **1003 „Cash in foreign exchange point of the licensed bank”**,
- Credit account **1001 „Cash in hand”**.

In order to record cash in foreign currency, the 1003 account opens analytical accounts for each type of currency.

For currency exchange bank sets a special rate for the foreign currency exchange. Thus, when buying foreign currency by the bank the accounting entry is:

- Debit account **1003 „Cash in foreign exchange point of the licensed bank”** (foreign currency),
- Credit account **1003 „Cash in foreign exchange point of the licensed bank”** (national currency)
- Debit/credit **4654 „Profit/loss from the sale of foreign currency”** – the difference between the authorized rate and the official one.

For the sale of foreign currency by the bank, the accounting entry is drawn inversely:

- Credit account **1003 „Cash in foreign exchange point of the licensed bank”** (national currency),
- Debit account **1003 „Cash in foreign exchange point of the licensed bank”** (foreign currency),

- Debit/credit **4654 „Profit/loss from the sale of foreign currency”** – the difference between the authorized rate and the official one.

The commission fee of the sale of foreign currency for individuals is 0.01%, and is reflected by the record book:

- Debit account **1003 „Cash in foreign exchange point of the licensed bank”**,
- Credit account **4674 „Bank commissions for the transactions of the sale / purchase of foreign currency.”**

In the Republic of Moldova, the transactions of collections and payments made with other countries are aimed at cash flows from foreign economic relations.

## CONCLUSIONS

The National Bank of Moldova is the main financial institution that has the right to issue normative acts regulating banking operations and transactions in foreign currency, and to issue and revoke licenses for determining positional restrictions for foreign commercial banks.

Following the purchase and sale transactions of foreign currency commercial, banks can obtain both a certain profit from the commissions for selling the currency or from the difference between the rate of foreign currency purchase and sale as well as loss of the difference between the official National Bank of Moldova rate and the authorized rate of the bank.

The accounts in foreign currency after performing selling and buying transactions of foreign currency are held to show the same synthetic accounts as well as accounts in national currency, **2224 "Current accounts of legal entities."**

## REFERENCES

- [1] Financial Institutions Act no. 550 - XIII of 21 July 1995 in the Official Gazette of the Republic of Moldova. 2010 nr.110-113/334 (with subsequent amendments).
- [2] Grigoriță, C. Banking. Ch: Cartier, 2005. 317-372 p.
- [3] Law on Foreign Exchange Regulation No.62-XVI of 21.03.2008. In: Official Gazette of the Republic of Moldova. 2008 nr.127-130 / 496. (with subsequent



amendments).

[4]Regulation on the terms and conditions of foreign exchange transactions. In: Official Gazette of the Republic of Moldova. 2010, no. 41-43 / 177.

[5]Regulation on Foreign Exchange Entities. In: Official Gazette no. 62-64 from 27.03.2009 (with subsequent amendments).



## THE IMPACT OF GOVERNMENT INTERVENTION ON AGRICULTURAL INDUSTRY: A CASE STUDY IN THE ISRAELI RAW MILK INDUSTRY

Tal SHAHOR, David DRORY

The Academic College of Emek Yezreel, Emek Yezreel 19300, Israel,

Emails: tals@yvc.ac.il; david6drori@gmail.com

*Corresponding author:* tals@yvc.ac.il

### Abstract

*This research studies the effect of government intervention on the Israeli raw milk industry by examining the relationship between the producers' costs and the price of milk. Like in many other countries, the government is actively involved in the Israeli agricultural market, including the raw milk production industry. The goal of government intervention is to ensure regular production and supply of basic, necessary milk products. Intervention manifests through the setting of production quotas and the price that the dairy farmers receive when selling their milk. According to accepted economic theory, the price that the government is supposed to set is the same one that would arise through a competitive market. The purpose of this research is to study the relationship between the price and marginal cost over two periods. The first period is from the years 1974 through 1994 and the second period is from 2010 through 2012. In the time between these two periods a fundamental change to the industry occurred in terms of the way the government interacted with the farmers. It will be interesting to see if the government policy change has an effect on the relationship between the price of milk and the marginal cost of the dairy farmers. The results of this study show that the price of milk is higher than the marginal cost, but the markup in both periods (1974 to 1994 and 2010 to 2012) is not particularly high.*

**Key words:** government intervention, market power, markup, raw milk

### INTRODUCTION

In a competitive market, the marginal cost is equal to the output price and there is an efficient allocation of resources. However, in a market in which firms have market power, the allocation of resources is not efficient, and therefore the existence of market power must have a damaging effect. Since this hurts public welfare, governments are in the unique position to reduce it. In industries with government imposed quotas, the size of the market power is especially relevant.

If market power exists, then the output prices are higher than the marginal costs. The efficiency of the market is damaged and therefore the government must set the quotas in such a way that the price will be as close as possible to the marginal costs. In the Israeli industry for the production of raw milk, the government sets production quotas. Raw milk is the milk that is milked from the cows, but which has not yet undergone any industrial processes. The purpose of this research is to measure the size of the market power in the

raw milk industry in Israel. Measuring market power is done with the assumption of full certainty in the marketplace, but in reality the raw milk producers function with a degree of uncertainty. When there is uncertainty and producers are risk averse, the price should be higher than the marginal costs (in order to compensate for the uncertainty). Therefore, we don't expect that the price will be equal to the marginal costs, but we also don't expect that the difference will be too big (according to criteria which will be discussed in the following sections). The existence of market power can come about from additional economic influences. According to Muller (2006), market power is one of the factors that can influence the price levels, as well as the reaction of the market to the business cycle. [9]

Additional studies, such as Banerjee and Russell (2005), found that there is a connection between market power and inflation. [2]

Bjørnstad and Kalstad (2010) found that

market power can influence wage levels. [3]  
 A possible measure for market power is "markup." The markup is the ratio of the price to the marginal cost. In perfect competition, the markup is one, and it will increase as the market power of the producer increases. The question this research study seeks to answer is: "what is the size of the markup in the raw milk industry in Israel?"

### Measuring the market power of a single firm

At first glance, in order to measure the markup it is enough to check how the manufacturer uses one input. The condition for maximum profit is:

$$(1) \quad MC = \frac{p_j}{mp_j}, \quad j=1,2,\dots,N$$

where  $j=1,2,\dots,N$  are the variable inputs,  $p_j$  is the price of input  $j$  and  $mp_j$  is the marginal output of input  $j$ . The desired markup is given by:

$$(2) \quad M = \frac{P}{MC}$$

where  $P$  is the price of one unit of output. From the above equation, the markup is able to be calculated with the help of each one of the variable inputs. In this study we assume that in the dairy farming industry, the most suitable input is the number of cows in the herd.

## MATERIALS AND METHODS

The sample we were able to work with in this industry consists of data from 41 collective dairy farms in the northern region of the country. The data was gathered from The Organization of the Dairy Farmers of the Valley Agricultural Center, which operates for the instruction and development for the dairy industry in the northern region of the country. Within this framework the organization gathers detailed data about the larger collective dairy farms which are in the region. The average number of cows per dairy farm is 429, ranging from 241 cows in the smallest dairy farm to 1,107 cows in the largest dairy farm. The database does not include information about the family dairy farms whose herd size stands at only a few

tens of cows. Because of the need to calculate the differences over the years, the regression requires data over at least three years. Similarly, the data for the fertility rate is supposed to be for the previous year, and therefore we need information for one additional year. The three years over which the study was done were the years 2010 – 2012.

Calculating the markup: Many studies have attempted to measure market power with the help of the markup. Hall (1988) calculated the markup by dividing the "elasticity of production with respect to work" by the labor share. Abbott, Griliches & Hausman (1988) and Eden & Griliches (1993) added the utilization rate of the labor to the regression which estimated the elasticity of. [1, 6]

Domowitz, Hubbard & Petersen (1988) repeated the technique of Hall by using the raw materials inputs instead of labor inputs. [5]

In all of these studies there is the problem of having to estimate the production function.

A different group of researchers tried to avoid the need to estimate the production function. There is usually available data about the state of the market (such as prices and amounts), as well as on exogenous variables that can influence the firms expenditures. Bresnahan (1989) pored over studies that were done according to the above conditions. [4]

An interesting development in the aforementioned technique appears in a study by Finkelstein & Kachel (1996) who used data on the marketing of agricultural products for two separate markets in order to estimate the market power of the agricultural industry in Israel. [7]

In this study we will estimate the market power of the raw milk producers by estimating the markup using a technique based on Hall (1988) [8], whereby the markup is:

$$(3) \quad M = \frac{P}{MC}$$

We will see that the markup can be estimated by dividing the "production elasticity with respect to any factor" by "the share of this factor in the final sale". In this study the production factor that we will use in order to

calculate the market power is the number of cows, which will be denoted by  $K$ . Specifically, we will define the production elasticity with respect to the number of cows by:

$$(4) \quad \beta_k = \frac{\Delta V/V}{\Delta K/K},$$

where  $V$  is the output (which will be defined more precisely later). In addition, we will use  $Sk$  to denote the proportion of the cows at redemption, which is calculated as follows:

$$(5) \quad Sk = \frac{r * K}{P * V},$$

whereby  $r$  is the annual cost of a cow. This calculation will also be further defined later. With the help of the above definition we can see that:

$$(6) \quad \frac{\beta_k}{Sk} = \frac{\frac{\Delta V/V}{\Delta K/K}}{\frac{r * K}{P * V}} = \frac{P}{r} \cdot \frac{\Delta V/\Delta K}{\Delta V/\Delta K}.$$

The expression  $\frac{\Delta V}{\Delta K}$  is the marginal output.

Therefore

$$(7) \quad \frac{r}{\Delta V/\Delta K} = MC.$$

If we substitute (7) into (6) we get

$$(8) \quad \frac{\beta_k}{Sk} = \frac{P}{MC} = M.$$

The dairy farming industry: The dairy farming industry in Israel functions by way of government planning. There are a few implications:

1. All the raw milk is marketed in a centralized way.
2. Each farmer has a fixed manufacturing quota.
3. At any time, the price which the farmers receive for their milk is constant and known in advance.
4. When there is a need to change the price of raw milk because of changes in the input prices, the matter is addressed by the government representatives.

In order to see the motivation for checking the markup in this industry, let us recall an article by Stigler (1971), which dealt with a situation in which a cartel develops due to government involvement. [13]

Stigler's basic assumption says that

government intervention in certain industries derives from political considerations, and not from economic or social ones. In accordance with this method, the political party in power takes administrative steps (like granting subsidies, rationing production quotas, limiting imports, etc.) which enable the industry to accumulate market power, and in exchange the firms which operate in that industry grant the political party political support that is expressed as voting during elections, helping with organization, and financial contributions to campaigns. Against this approach is the claim that the goal of government intervention in industries such as the raw milk industry is the guarantee of regular availability of essential dairy products. In this case the government is supposed to set the prices in accordance with what they would be in a free market. Under conditions of market certainty the markup will be one.

In addition, under conditions of inflation it is necessary to update, from time to time, the price of raw milk. Seemingly, this is a simple matter that can be done by indexing the price of raw milk to an inflation index. The problem is that the index must be the input costs for the industry, and there could be controversy regarding the index as to changes in the prices of the inputs, or as to the makeup of the industry input basket. Therefore the updating is done by way of negotiations between representatives of the dairy farmers and the government.

#### **The production function of raw milk:**

The dependent variable – the value of the raw milk (denoted as  $V$ ):

The output of the dairy farming industry is not measured only by the amount of milk, but also by the percent of fat and amount of protein it contains since the higher the fat percentage and protein content are, the better the price the farmer gets for the milk. However, there is a trade-off between the percentage of fat and the amount of milk: the more the dairy farmer increases the percentage of fat in the milk (by way of altering the diet), the less milk there is. Therefore we need to weight the amount of milk with the amount of fat. The best way to do this is by using the price of milk because, from the perspective of the producer, the

effect of the fat percentage on his income is what matters. In order to calculate this weighted average we divide the price that each producer receives in each year by the average price of milk for that year. If  $\bar{p}_t$  is the average price of the whole industry in year  $t$ , and  $p_t^n$  is the average price of producer  $n$  in year  $t$ , then by multiplying  $p_t^n/\bar{p}_t$  by the amount of milk that farmer  $n$  in year  $t$  produced, we get the weighted amount of raw milk, in terms of its price.

### **The inputs**

**A. The number of cows** (denoted as  $K$ ): includes the cows which gave milk in the same period (and therefore does not include calves and cows about to give birth).

**B. Cost of food per cow** (denoted as  $F$ ): The cow like a machine that receives food as an input and yields milk. An increase in the amount of food will increase the amount of milk which the cow gives. Measuring the amount of food is a problematic subject because there are many types of food and each one has a different value. Therefore the measurement of a unit of weight or volume isn't relevant. For example, for 100 grams of a concentrated food –“mixture” there is more nutrition than 500 grams of hay or 1,000 grams of straw). For this reason, the food was measure by the amount of money that the dairy farmers spent on their purchases. This measure is based on the assumption that the dairy farmers operate efficiently, whereby the cost of food increases with the quality, or as the optimal amount increases.

**C. Labor costs per cow** (denoted as  $L$ ): If the cow is managed in an efficient manner, a larger amount of labor is considered to result in better care for the cows, which should increase the amount of milk.

**D. The fertility rate of the previous year** (denoted as  $Z$ ): This variable shows the rate at which the cows became impregnated during the course of the previous year. Immediately after the birth, cows give their maximum amount of milk, and after a few months the amount of milk begins to fall.

Therefore, the dairy farmers try to impregnate the cow (that is, to cause them to become pregnant), as soon as possible.

During the pregnancy the cow continues to give milk until a few weeks before the birth, so the dairy farmers “dry out the cow” by not milking her in order to allow her to rest. After the birth the regular process resumes. Impregnating the cows is no simple matter and requires taking a few steps, which carries a cost. Therefore, we can address the issue of fertilization (which is the percentage of cows that were impregnated in the same year) as a type of input. It takes nine months from the time of impregnation until birth, and therefore the fertilization affects the output of the next year. For this reason, last year's fertility rate appears in the production function.

**E. Breeding** (denoted by  $e^\tau$ ): One of the characteristics which stands out in the Israeli raw milk industry is the cultivation of the genetic material of the cowherds. The cultivation is done in two steps:

(i) Strict selection of the fathers: since most of the cow inseminations in Israel are artificial, a few tens of bulls are enough to inseminate all the cows in the country.

Therefore, it is possible (and highly recommended) to invest great effort, in order to ensure that the bulls are the best available. These bulls are chosen, firstly, according to the quality of their mothers, and then there is an additional selection process according to the quality of their daughters.

(ii) Choosing the calves: not all calves which are born in a dairy farm are raised to be dairy cows (with the rest sold for meat). When the dairy farmers choose the calves which they intend to raise, they consider the quality of their mothers.

As a result of both of these actions, there is a process which improves the quality of the cows which is expressed as an increase in the quantity of milk.

This increase occurs at a fixed rate, and therefore we can express the trend using the variable  $e^\tau$  where  $\tau$  takes a value of 1 for the first period, a 2 for the second, etc.

**Conclusion:** The production function for the dairy farm industry is:

$$(9) \quad V = e^\alpha (e^\tau)^{\beta_\tau} K^{\beta_k} F^{\beta_f} L^{\beta_L} Z^{\beta_z}.$$

A logarithmic transformation of the

production function yields the following equation:

$$(10) \ln(v) = \alpha_n + \beta_\tau \ln(\tau) + \beta_k \ln(K) + \beta_f \ln(F) + \beta_L \ln(L) + \beta_z \ln(Z) + \varepsilon$$

If we take the first differences of  $\ln$  over time, we get:

$$(11) dv = \beta_\tau + \beta_k dk + \beta_f df + \beta_L dl + \beta_z dz + \varepsilon$$

where  $dx_t = \ln(X_t) - \ln(X_{t-1})$

The reason for using the differences across time is to eliminate  $\alpha_n$ . In addition, as we previously defined, the variable  $\tau$  increases in value each year by 1. Therefore, if we take the difference between the years, this variable disappears and we are left with its coefficient  $\beta_\tau$ .

In order to perform the check, we will recall, that from equation (8) we get:

$$(12) \beta_k = M \cdot Sk$$

If we substitute  $\beta_k$  into equation (11) we get:

$$(13) dv = \beta_\tau + M \cdot (Sk \cdot dk) + \beta_f df + \beta_L dl + \beta_z dz + \varepsilon$$

In this equation the second independent variable is the product of  $Sk$ ,  $dk$ , and the coefficient  $M$ , is the required markup.

Noise in the regression: The cows are, perhaps surprisingly, very sensitive as a production factor. Therefore, each “malfunction” in care has the possibility of causing heavy damage. For example, the cows are fed a number of times each day at fixed hours. A delay in feeding time has an immediate, negative impact on the amount of milk the cow will produce. Another example: the wrong care at the time of milking also translates into an immediate loss of milk as well as long term damages. During the day to day operations there are many setbacks, of which some are caused by external factors such as problems with the tractors or problems with the milking machines, and some are caused by human error. Since we are unable to put these setbacks into our production function, they appear as noise in the regression. These setbacks are not connected to any of the independent variables in the regression and therefore we can assume that the noise of the regression and the independent variables are independent of one

another.

## RESULTS AND DISCUSSIONS

As stated above the formula for calculating  $Sk$  is  $Sk = \frac{r \cdot K}{P \cdot V}$ . To calculate this variable we

need the following information:

- $P \cdot V$  – The total annual revenue for all the dairy farms in the sample. In 2012 this was 438,138,258 NIS.
- $K$  – The number of cows in all the dairy farms in the sample. In 2012 there were 17,597 cows.
- $r$  – The price of  $K$ . This is the annual cost of a milk giving cow. The average lifespan of a cow in the herd is five years, however a cow only begins to give milk in the third year of its life, rendering its economic life only three years.

The annual cost of a milk cow (the size of  $r$ ) is made up of three components:

- (1) The cost of a new cow that joins the herd and begins to give milk: The dairy farmers can purchase new cows, but usually they prefer to birth and raise their own calves by themselves. Raising a calf from birth until it begins to give milk (and becomes a “milk cow”) takes two years. The average cost in 2012 was ₪9,280. However, we are interested in the average annual cost of a milk cow. Therefore the cost to raise a cow for one milking year is ₪3,093 (which we get by dividing the cost to raise the calf by three).
- (2) The annual cost of food and additional costs for a milk cow: In 2012 this cost was ₪14,000.
- (3) The money made from the sale of cows for meat: When a cow reaches the end of its life it is sold to meat producers. The money received from the sales of meat offsets some of the costs of keeping the dairy cow and therefore it must be deducted from the other two amounts. The average receipt for selling a cow for meat in 2012 was ₪4,591. We arrive at the annual income received from selling

meat by dividing the above amount by three, which gives us  $\approx 1,530$ .

The sum of these three amounts show that in 2012,  $r = 15,564$  and  $Sk = 0.625$ .

The market power size: The results of the regression of equation (13) appear in the table below:

Table 1. Regression results and the size of the markup

Variable	Coefficient
Sk*K	1.297
Cost of food for one cow	0.3
Adjusted R-squared	0.72

As can be seen from the table, the size of the markup is 1.297 which means that the price of the final product is higher than the marginal cost. Sandmo's (1971) argument states that the absence of market power must lead to parity between the marginal cost and the price, but only if the market conditions are known with certainty or, alternatively, that the producer is indifferent to risk. [10]

If there is uncertainty regarding the price of the output, the prices of the inputs, or the amount of output, then risk aversion will result in a decrease in the optimal output for the producers. From here it follows that if there is uncertainty in a system, with risk averse producers, then even if the producers do not have market power, the expected price will be greater than the (sum of the) marginal costs, and the markup will be greater than one. Therefore, from the above discussion, in order to determine if the dairy farmers of Israel have a lot of market power (which would require a decrease in the price of raw milk), we need to compare the markup here with the markups of other industries.

In a study by Shahor (2011) which looked at the markup in the Israeli banana industry, he found that the markup stands at around 1.92. [11]

Therefore when compared to the banana industry we can see that the market power of the dairy farmers in Israel is not particularly large. However, we need to remember that in the banana industry the level of risk is much greater and therefore the risk premium in the banana industry is much greater. We can

conclude by saying that for the Israeli dairy industry there is some sort of market power, but in order to determine if it is too much, and in order to properly phrase a recommendation as per the required government policy, further research in other industries of similar risk to the dairy industry must be conducted. Alternatively, one could calculate the relevant risk premium for this industry.

In a Previous study by Shahor (1995) which looked at the markup in the Israeli raw milk industry during the years 1974-1994 he found that the markup stands at around 1.25. [12]

As you can see, despite the many changes that occurred over the years, No significant change has occurred in the market power of this industry.

## CONCLUSIONS

In this research study we checked the market power of the raw milk producers in Israel. We measured the market power using the markup, which we calculated by dividing the output price by the marginal costs. The raw milk producing industry is particularly interesting because the price of milk the producers receive is set by the government. The price the government is supposed to set in situations such as this is the price that would result in a free market. Under conditions of absolute certainty or indifference to risk, this price must be equal to the marginal costs, and the markup should be equal to one. If, on the other hand, there is uncertainty in the production system (which is what always happens in reality) and the producers are risk averse, the producers add to the price of the product a risk premium. Therefore, even under free market conditions, the markup will be greater than one. The results of the study suggest that the markup of the raw milk production industry is 1.29, which of course is greater than one.

In comparison with the banana industry, whose markup was measured to be 1.92 in the past, it can be seen that in the Israeli raw milk production industry there is a degree of market power held by the producers. However, in order to determine its strength there is a need for further research about the



markup in other industries with similar risk. An alternative would be to estimate the relevant market premium in the raw milk industry. As stated above, a study that examined the markup in 1974 to 1994 found similar results. These aforementioned things can show that, the intervention of the government in the raw milk industry does not derive only from the relationship of the producers and the political system, as Stigler claimed.

## REFERENCES

- [1]Abbott, T., Griliches, Z., Hausman, J., 1988, Short Run Movements in Productivity: Market Power Versus Capacity Utilization. Unpublished manuscript presented at the NBER Summer Institute, Cambridge MA.
- [2]Banerjee, A., Russell, B., 2005, Inflation and measures of the markup. *Journal of Macroeconomics*, Vol. 27(2): 289–306.
- [3]Bjørnstad, R., Kalstad, K.O., 2010,. Increased Price Markup from Union Coordination—OECD Panel Evidence. *Economics: The Open-Access, Open-Assessment E-Journal*, Vol. 4, 2010-30. doi:10.5018/economics-ejournal.ja.2010-30, <http://dx.doi.org/10.5018/economics-ejournal.ja.2010-30>.
- [4]Bresnahan, T. F., 1989. Empirical Studies of Industries with Market power. In Schmalensee R. & R.D. Willing, *Handbook of Industrial Organizations*, New York: north Holland. 1011-57.
- [5]Domowitz, I., Hubbard, R., Petersen, B., 1988, Market Structure and Cyclical Fluctuations in U.S. Manufacturing. *Review of Economics and Statistics*. Vol. 70, 55-65.
- [6]Eden, B., Griliches, Z., 1993, Productivity, Market Power and Capacity Utilization When Spot Market Are Complete. *A.E.A. Papers and Proceedings*, vol. 83, 219-223.
- [7]Finkelstein, F., Kachel, Y., 1996, Testing for Multimarket, Multiproduct Monopolistic Pricing in the Israeli Citrus Export to Europe, mimeo.
- [8]Hall, R., 1988, "The Relation Between Price and Marginal Cost in U.S Industry. *The Journal of Political Economy*, Vol.14 (1), October, 921-947.
- [9]Muller, C., 2006, Further results on monopolistic competition, markup pricing and the business cycle in Switzerland. *Empirical Economics*, Vol. 31(3), 755 – 776.
- [10]Sandmo, A., 1966, On The Theory of the Competitive Firm Under Price Uncertainty. *American Economic Review*, Vol. 61(1), 65-73.
- [11]Shahor T., 2011. Hyper Inflation and Market Power in Agriculture - A Case Study in the Banana Industry in Israel. *International Journal of Economics and Research*, vol. 2 (3), 136-147.
- [12]Shahor, T., 1996, Inflation and Market Power in Agriculture: A case study in the Banana Industry in Israel. Ph.D. Dissertation, Haifa University. Supervisors: Prof. Ben Eden. Hebrew
- [13]Stigler, J. G., 1971, The Theory of Economic Regulation. *Bell Journal of Management Science*, 2 (1), 3 - 21.



## GREENHOUSE GASES: CAUSES, LOSSES AND REMEDIAL MEASURES FOR SUSTAINABLE AGRICULTURE

P. S. SHEHRAWAT, Rati MUKETSHWAR

Choudhary Charan Singh Haryana Agricultural University, Department of Agricultural Extension, Hisar-125004, India, Mobile: + 91 94161, Fax + 91 1662 234952, Email: psshehrawat1965@gmail.com

*Corresponding author email:* psshehrawat1965@gmail.com

### Abstract

The result predicted that major causes of greenhouse gases were found 'high use of inorganic farm inputs' (2.88), 'intensive tillage practices' (2.75), 'mechanization of farm practices', (2.66), 'non- adoption of diversified agriculture' (2.52), 'non-adoption of crop rotation; (2.46), and 'burning of crop residue in field' (1.95) with their respective weighted mean scores. The losses due to greenhouse gases were found 'crop benefit ratio decreased' (1.23), 'crop damaged due to adverse climatic uncertainty' (1.07), 'crop production decreased' (0.89), 'sowing season change (0.86), 'loss in bio-diversity' (0.84), 'less income from agriculture' (0.81), 'soil water holding capacity decreased' (0.68) based on their 'Z' scores. Results pertaining adoption of remedial measures for sequestration of greenhouse gases for sustainable agriculture were 'evolution of new crops cultivars' (2.95), 'crop diversification' (2.90), 'use zero tillage practices' (2.81) 'integrated farming system' (2.79) 'adapting cultivars against drought, pests, diseases, resistance' (2.78), 'soil/water testing for soil status' (2.77), 'encouraging of rice varieties that emit less CH<sub>4</sub> (2.73), 'campaigning for sequestration of GHGs (2.67)', 'growing intercrops/mixed cropping to compensate crop failure', (2.62) and 'management of natural resources soil, water and biodiversity' (2.61) considered very effective remedial measures with their mean scores, respectively.

**Key words:** causes, greenhouse gases, losses, remedial measures, sustainable agriculture

### INTRODUCTION

GHGs are the responsible for increase in the temperature of the earth. It happens when gases like carbon dioxide (CO<sub>2</sub>), methane (CH<sub>4</sub>), nitrous oxide (N<sub>2</sub>O) and water vapour trap heat and light from the sun in the earth's atmosphere, which increases the temperature. This hurts many people, animals and plants. GHGs have an impact on our planet, agriculture, human and animals lives. Considering the seriousness of undesirable effect of GHGs problems, everyone should come forward to resolve these calamities. Perhaps, the application of the scientific knowledge and recommended farm practices to reduce the emission of GHGs is the best alternative for effective and sustainable development of agriculture.

In an effort to combat against sequestration of GHGs issues related to agricultural development, agricultural research scholars as a future generation of agricultural development need to possess awareness and perception about GHGs emission causes and losses occurred. The application of awareness

and perception about GHGs hold tremendous potential to save earth and agriculture. Forced and timely efforts to apply knowledge by the agricultural research can enable them to stand successfully against the emission of GHGs problems to play a leadership role in overall development of agriculture.

To get complete benefit using the knowledge of GHGs, climate change and global warming, agricultural research scholars must prepare themselves to act as a leader of future generation in the development process as a change agent to save earth and agriculture. Realizing significant role of agricultural professional in the sustainable of agriculture in dealing with GHGs emission problems, a study was undertaken to assess the farmers' perception regarding causes, losses occurred due to GHGs emission and to find out suitable alternative measures for sequestration of GHGs emission.

### MATERIALS AND METHODS

The present study was conducted in Haryana state. Two districts Hisar and Karnal were selected, purposively, because multiple

cropping systems are practiced in these districts. A total number of eight villages were selected, randomly then from each village, 15 farmers were selected, randomly. Hence, a total number of 120 farmers were interviewed. The data were collected personally by the researcher through a well-structured interview schedule containing items pertained the objective of the study. Qualitative data were quantified, appropriately tabulated and analyzed, and standardized statistical techniques as percentage, weighted mean score and Z score were implied to draw meaningful inferences.

For calculation causes, an inventory was developed containing 24 statements explaining the possible causes to measure the awareness and perception about the losses due to GHGs emission. The respondents were asked closed ended questions and were asked to reply for each possible cause. A list of causes was prepared and farmers were asked to speak out their response against each cause, whether it was 'very serious', 'serious' and 'not so serious' and a weightage of 3, 2 and 1 were assigned to their responses, respectively. Then aggregate total score was calculated for each cause separately, and based on, calculated total score and weighted mean scores was obtained and ranked according to the maximum or minimum mean score possessed for assessing the seriousness of constraints.

For quantification of losses due to emission of GHGs, an inventory was developed containing 22 statements pertaining possible losses to measure the awareness about the losses due to GHGs emission the respondents were asked closed ended questions and to reply as 'very serious', 'serious' and 'not so serious' and weightages given to their responses category were 3, 2 and 1, respectively. An aggregate total score was calculated for each cause separately, and based upon this total score obtained, a mean score for each loss was calculated for assessing the seriousness of loss occurred.

On the other hand, after judging the responses of all the respondents for obtaining losses on a three-point continuum rating scale, the total score for losses was worked out and this total

score was converted into weighted mean score. Finally, a 'Z' score was obtained for judging the seriousness of each loss contained in the schedule by using the formula as under:

$$Z \text{ score} = \frac{X - \bar{X}}{SD}$$

Finally, for measurement of suitable alternative measures for sequestration of GHGs emission through farm practices, an inventory was prepared containing 32 statements of suitable alternatives for sequestration of GHGs for healthy environment for agriculture. The respondents were asked closed ended questions to reply as 'very effective', 'effective' and 'not so effective' against each alternative and a weightage of 3, 2 and 1, were given, respectively based on their responses. Aggregate total score was calculated for each alternative measure separately, and based on calculated total score, a weighted mean score were obtained and rank assigned which were ranked according to the maximum or minimum mean scores for assessing the effectiveness of alternative measure.

The maximum mean score percentage so obtained was given the rank 1<sup>st</sup> and the next subsequent one was given 2<sup>nd</sup> and so on the descending orders.

## RESULTS AND DISCUSSIONS

### Causes for emission of greenhouse gases (GHGs)

The data from the Table 1 revealed that 'high use of synthetic fertilizers/chemicals' was considered the very serious cause by the respondents and ranked 1<sup>st</sup> as per the mean score (2.88), followed by 'intensive tillage practices' (2.75), was ranked 2<sup>nd</sup>, 'low availability of organic fertilizers/manures' was 3<sup>rd</sup> in rank and 'mechanization of farm practices' (2.70), was ranked 4<sup>th</sup>, 'intensive cultivation of soil organic content' (2.66) and ranked 5<sup>th</sup>, 'crop residues deposition under wet condition' was ranked 6<sup>th</sup> as per the mean score (2.60), and 'decomposition of animal manure in uncovered lagoons' (2.55) was ranked 7<sup>th</sup>.

Table 1. Causes of greenhouse gases emission (N = 120)

Sr. No.	Emission causes	Total Weighted Score	Weighted Mean Score	Rank Order
1.	High use of synthetic/chemicals fertilizers	346	2.88	I
2.	Intensive tillage practices	330	2.75	II
3.	Low availability of organic fertilizers/manures	325	2.70	III
4.	Mechanization of farm practices	320	2.66	IV
5.	Intensive cultivation of soil organic content	317	2.64	V
6.	Crop residues deposition under wet condition	313	2.60	VI
7.	Decomposition of animal manure in uncovered lagoons	307	2.55	VII
8.	Clearing of natural vegetation/ Deforestation	305	2.54	VIII
9.	Non adoption of diversified agricultural practices	303	2.52	IX
10.	Burning of agricultural residues in the field	300	2.50	X
11.	Non adoption of different crop rotation	296	2.46	XI
12.	Lack of pastures in rural areas	294	2.45	XII
13.	Leach down of soil carbon, water, nutrients and fertilizers	293	2.44	XIII
14.	Exhaustive pumping up of underground water for irrigation	282	2.35	XIV
15.	Over cultivation	268	2.23	XV
16.	Intensive agricultural practices	263	2.19	XVI
17.	Conservation of grassland into cultivated lands	246	2.05	XVII
18.	Land degradation	237	1.97	XVIII
19.	Burning of fossil fuels (coal, oil and natural gas)	234	1.95	XIX
20.	Enteric fermentation in domestic livestock	228	1.90	XX
21.	Flood irrigation practices	203	1.69	XXI
22.	Early leach down of fertilizers in soil	197	1.64	XXII
23.	Urine and faeces deposition in grazed pastures	180	1.50	XXIII
24.	Rice cultivation leads to CH <sub>4</sub> and N <sub>2</sub> O	170	1.41	XIV

(Figures in parentheses in column 3 indicate total weighted score; columns 4 indicate weighted mean scores and column 5 indicate rank order)

The data also revealed that the cause ‘clearing of natural vegetation/ deforestation’ (2.54) was ranked 8<sup>th</sup>, ‘non adoption of diversified agricultural practices’ (2.52) was ranked 9<sup>th</sup>, ‘burning of agricultural residues in the field’ and ‘non adoption of different crop rotation’ were as ranked 10<sup>th</sup> and 11<sup>th</sup> as per their mean scores (2.50) and (2.46), respectively (Table 1). It was also found in the study that awareness among the farmers about the causes of GHGs emission was low to medium.

Most of the farmers in this study could know the causes, which are responsible for the emission of GHGs in agriculture. Farmers could not aware about the high uses of inorganic inputs, which are, enhance the emission of GHGs, they used inorganic farm inputs only for increased the crop production. In conformity of the results, it was also reported that deforestation for agriculture crop fields and pastures, transforming virgin soil into cultivated land and utilizing nitrogenous fertilizers, are all implicated in release of GHGs in the atmosphere [6].

Mostly farmers burned their crop resides on their fields and not interested to follow the recommended crop rotation and farm practices because they more emphasis on cash crops for high returns. Most of the farmers’

decomposes of animals’ manures in uncovered lagoons, which increased the emission of GHGs, and enteric fermentation in domestic animals were highly responsible for the emission of GHGs

#### **Farmers’ perception regarding losses occurred due to emission of GHGs**

The Table 2 revealed that the ‘crop benefit ratio decrease’ (Z score 1.23) and ‘crop damage due to adverse climatic uncertainty’ (Z score 1.07) were considered as very serious losses in agriculture due to emission of GHGs by the respondents as per the ‘Z’ score.

The data revealed that ‘crop production decreased’ (Z score 0.89) followed by ‘sowing season changed’ (Z score 0.86), ‘loss in bio-diversity (Z score 0.84), ‘less income from agriculture’ (Z score 0.81) were found serious losses as per Z score perceived by the respondents.

It is obvious from the Table 2 that ‘soil water holding capacity decreased’ (Z score 0.68), ‘deeper level of ground water table’ (Z score 0.31), ‘cropping pattern and cropping system changed’ (Z score 0.28), ‘high usages of synthetic or inorganic fertilizers’ (Z score 0.23), ‘soil fertility decreases’ (Z score 0.13) and ‘degradation of forests to barren lands’ (Z score 0.10), ‘soil erosion’ (Z score 0.07), and

'cropping intensity decreased' (Z score 0.00) were also serious losses in nature according to the respondents' responses and so on.

Due to emission of GHGs, farmers found losses in their crop production and they shifted their cropping pattern due to uncertainty of climate conditions. Environmental temperature have been raising that because of GHGs emission and affecting the crop cycle.

Crop mature earlier because of high temperature and sometime late mature due to low temperature. Cropping season changed due to GHGs emission. Soil temperature affects the rate of organic matter

decomposition and release of nutrients.

At high temperature, though nutrient availability will increase in the short term, in long run organic matter content will diminish resulting in decline in soil fertility [3].

On the same lines, have estimated that under the situation of doubling of carbon dioxide in the atmosphere the wheat yields could decrease by 28 to 68 per cent without considering the carbon dioxide fertilization effects.

Yield of C<sub>3</sub> crops like wheat, barley, rice, and potatoes may increase by 30% due to CO<sub>2</sub> fertilization [2] and [1], (Fig.1).

Table 2. Losses due to greenhouse gases emission (N = 120)

Sr. No.	Losses	Total Weighted Score	Weighted Mean Score	Z Score	Nature of Seriousness
1.	Crop benefit ratio decreased	335	2.79	1.23	VS
2.	Crop damaged due to adverse climatic uncertainty	328	2.73	1.07	VS
3.	Crop production decreased	320	2.66	0.89	S
4.	Sowing season changed	314	2.65	0.86	S
5.	Loss in biodiversity	317	2.64	0.84	S
6.	Less income from agriculture	316	2.63	0.81	S
7.	Soil water holding capacity decreased	310	2.58	0.68	S
8.	Deeper level of ground water table	293	2.44	0.31	S
9.	Cropping pattern and cropping system changed	292	2.43	0.28	S
10.	High usages of synthetic or inorganic fertilizers	290	2.41	0.23	S
11.	Soil fertility decreased	285	2.37	0.13	S
12.	Degradation of forests to barren lands	284	2.36	0.10	S
13.	Soil erosion	283	2.35	0.07	S
14.	Cropping intensity decreased	279	2.32	0.00	S
15.	Change of land for housing/industrial usage/SEZ	278	2.31	-0.02	S
16.	Quality deterioration of crop produce	275	2.29	-0.07	S
17.	Crop loss due to flood and drought	273	2.27	-0.13	S
18.	Quitting agriculture leads unemployment	270	2.25	-0.18	S
19.	Desertification due to prolonged drought	257	2.14	-0.47	S
20.	Reduction in soil carbon stocks	239	1.99	-0.86	S
21.	Frequent crop failure	227	1.89	-1.13	NSS
22.	Loss in soil organic matter	213	1.77	-1.44	NSS

$\bar{X} = 2.00$  VS Very Serious  
 S.D. 0.38 S Serious NSS Not so serious

Farmers' experiences high uses of chemical inputs to control the pest and diseases attack on the crop but they found less control on them and the amount of application of chemical inputs increases season after season. Farmers noticed that the groundwater table goes down due to low rainfall, farmers did not aware about the GHGs emission, and climate change is responsible for low rainfall. Farmers also experiences degradation of forestland into barren lands, soil productivity decreases, more soil erosion and soil salinity increases and crop loss due to adverse climate condition perhaps the major reason that farmers are quitting the agriculture. The income from the

agriculture decreased day by day and now agriculture has becoming a risky profession. Similar threats were also quoted [5] that in tropical countries even moderate warming (1<sup>0</sup> C for wheat and maize and 2<sup>0</sup> C for rice) can reduce yields significantly because many crops are already at the limit of their heat tolerance.

**Alternative measure for sequestration of greenhouse gases:-**

An analysis of the data from the Table 3 revealed that 'evolution of new crops cultivars' (2.95) was perceived as very effective alternative measures and 1<sup>st</sup> rank was given, followed by 'Crop diversification'

(2.90), ‘use zero tillage practices’ (2.81) and ‘Integrated farming system’ (2.79) and a rank order 2<sup>nd</sup>, 3<sup>rd</sup> and 4<sup>th</sup> were given, respectively.

‘Adapting cultivars against drought, pests, diseases, resistance’ (2.78) ranked 5<sup>th</sup> as per mean score.

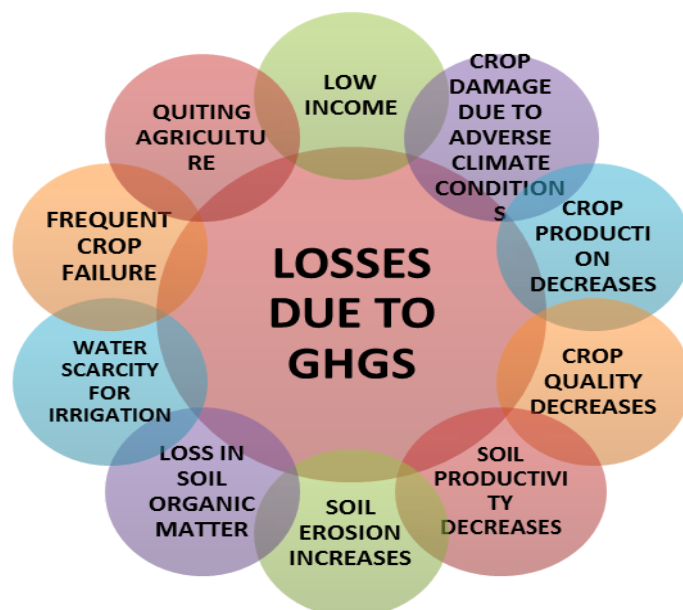

Fig. 1. Major losses due to GHGs in Agriculture

Table 3 further represents ‘soil/water testing for soil status’ (2.77) and ‘Encouraging of rice varieties that emit less CH<sub>4</sub>’ (2.73) were found very effective alternative measures for sequestration of GHGs and their rank order were assigned 6<sup>th</sup>, 7<sup>th</sup> and 8<sup>th</sup> followed by ‘campaigning for sequestration of GHGs’ (2.67) was ranked 9<sup>th</sup>. The other alternatives were found as ‘Growing intercrops/mixed cropping to compensate crop failure’ has ranked 10<sup>th</sup> with mean score 2.62 and ‘management of natural resources soil, water and biodiversity was ranked 11<sup>th</sup> with mean score 2.61 perceived by the farmers. Next suitable measures were found as ‘Soil conservation measures’ (2.57), ‘reduce tillage practices’ (2.56), and ‘use Indigenous traditional knowledge (ITK) for crop production’ (2.55), and ‘water harvesting management practices’ (2.50) ranks were given 12<sup>th</sup>, 13<sup>th</sup>, 14<sup>th</sup> and 15<sup>th</sup>, respectively. The respondents perceived that adoption micro irrigation (drip/sprinkler) (2.49), ‘Use remote sensing technologies for analysis of vegetation and soil carbon’ (2.48), ‘application of compost/FYM/Green manuring (2.47), ‘enhancing the area under agro-forestry and social forestry’ (2.45) and ‘organic farming practices’ (2.42) and their

rank order were 16<sup>th</sup>, 17<sup>th</sup>, 18<sup>th</sup>, 19<sup>th</sup> and 20<sup>th</sup>, respectively as per mean score and this type of alternative measures consider as effective alternative measures as per farmers response (Table 3).

For future prospective sequestration of GHGs is important and necessary to sustain the agriculture, environment and human also. Mitigation of GHGs is beneficial to the whole environment because GHGs amplify the climate change and global warming.

Majority of the respondents required that scientists released new or improved variety or cultivar for more production. Farmers also interested to adopt diversified agriculture practices. The findings were supported that organic and green manures as well as nitrogen from legumes can be managed very precisely due to the design of the crop rotations including cover and catch crops [8].

In conformity, another study on the integrated use of different organic fertilizers such as improved fallow and FYM provided encouraging results in increasing maize grain yield and improving soil chemical properties at eastern Ethiopia [4]. Most of the respondents had good knowledge about the sequestration of the GHGs by the adoption of farm practices. Farmers’ use their indigenous

knowledge for crop production. Farmers also aware about the hazardous effect of GHGs, climate change and global warming on human

health and environment and they want to adopt healthy agriculture practices such as organic farming.

Table 3. Alternative measures for sequestration of greenhouse gases (N = 120)

Sr. No.	Alternative Measures	Total Weighted Score	Weighted Mean Score	Rank Order
1	Evolution of new crops cultivars	355	2.95	I
2	Crop diversification	349	2.90	II
3	Use zero tillage practices	338	2.81	III
4	Integrated farming system	335	2.79	IV
5	Adapting cultivars against drought, pests, diseases, resistance	334	2.78	V
6	Soil/water testing for soil status	333	2.77	VI
7	Encouraging of rice varieties that emit less CH <sub>4</sub>	328	2.73	VII
8	Campaigning for sequestration of GHGs	322	2.68	VIII
9	Evolution of crop varieties from long duration to short duration	321	2.67	IX
10	Growing intercrops/mixed cropping to compensate crop failure	315	2.62	X
11	Management of natural resources soil, water and biodiversity	314	2.61	XI
12	Adopting soil conservation measures	309	2.57	XII
13	Reduce tillage practices	308	2.56	XIII
14	Use Indigenous traditional knowledge (ITK) for crop production	307	2.55	XIV
15	Water harvesting management practices	301	2.50	XV
16	Adoption micro irrigation (drip/sprinkler)	299	2.49	XVI
17	Use remote sensing technologies for analysis of vegetation and soil carbon	298	2.48	XVII
18	Application of FYM/ compost//Green manuring	297	2.47	XVII
19	Enhancing the area under agro forestry and social forestry	295	2.45	XIX
20	Organic farming practices	291	2.42	XX
21	Improved rice cultivation techniques	288	2.40	XXI
22	Improved nitrogenous fertilizers to restrict leaching and volatilization	286	2.38	XXII
23	Afforestation and reforestation practices	285	2.37	XXIII
24	Adoption of precision farming practices	282	2.35	XXIV
25	Suitable crop rotation and cover crops	270	2.25	XXV
26	Prevent CH <sub>4</sub> emission from manure heaps and tanks	256	2.15	XXVI
27	Shifting from food crops into perennial crops	255	2.12	XXVII
28	Production of high residue yielding crops	236	1.96	XXVIII
29	Eco-friendly agriculture	235	1.95	XXIX
30	Covered manure pits and slurry storage	222	1.85	XXX
31	Including more hay crops in annual rotations	208	1.73	XXXI
32	Reduction in fallow period between two crops for green manuring	200	1.66	XXXII

(Figures in parentheses in column 3, 4 and 5 indicate percentages; columns 7 indicate weighted mean scores and column 8 indicate ranks order)

It have been estimated reduction in wheat production by 10 % under anticipated enhancement 0.5 0C in mean temperature in the high yield States of Punjab, Haryana and Uttar Pradesh [7].

## CONCLUSIONS

The study has made a very effective an inventory of causes and losses due to emission of green house gases by farmers. Farmers were found having many constraint of serious nature and these constraints can be minimized by providing availability of proper information, training, coordinating in-between

farmers and various organizations.

Efforts should be made for providing proper guidance, training and implementation of the recommended farm practices to farmers to reducing the GHGs emission from agriculture and for sustainable development in agriculture and for providing healthy environment for better livelihood.

The following suggestions are made for improving the adoption of recommended farm practices for sequestration of GHGs and mitigate GHGs from village to district and national to international level:

(i)The study further indicated that a significant majority of the respondents had



not adopted the recommended farm practices for sequestration of GHGs for sustainable agriculture. Therefore, it would be worthwhile for the extension functionaries to organize training, demonstration and take up appropriate educational;

(ii) To improve the adoption level, extension agencies should give more emphasis on the farm practices, which required specialized skills like zero tillage, integrated farming practices, resource management, adoption of remote sensing technology adoption of micro irrigation and more application of organic compost etc;

(iii) Literature regarding recommended farm practices to reduce the GHGs should be published in local language and made available to the farmers locally;

(iv) The planner and policy maker have to take up each constraint as a challenge and have to work on scientific lines to resolve these constraints or problems;

(v) Generating leadership at all levels with clear vision, comprehensive plans and implementation strategies to meet the challenges of GHGs;

(vi) Farmers' eco-club should be involved in awareness program regarding climate change and environmental degradation;

(vi) Capacity building program should be organized to educate the field extension functionaries about safe and healthy environment;

(vii) Cross train of all efforts should be made to provide healthy food for all;

(viii) Agriculturist, environmental engineers and dietician come together for safe environment, rich nutritive food and development of nature loving agriculture.

## REFERENCES

- [1] Aggarwal, P. K., Nagarajan, S., and Shibu, M. E., 2003, Climate Change May Affect Crop Quality. Financial Express.
- [2] Attri, S. D., Rathore, L. S., 2003, Simulation of Impacts of Projected Climate Change on Wheat in India. International Journal of Climatology. Vol. 23 (6): 693-705.
- [3] Katyal, J. C., 2000, Organic matter: mainstay of soil quality. J. Indian Soc. Soil sci. Vol. 48:704-716.
- [4] Negassa, W., Getaneh, F., Deressa, A. and Dinsa, B., 2007, Integrated Use of Organic and Inorganic

Fertilizers for Maize Production. Utilization of diversity in land use systems: Sustainable and organic approaches to meet human needs.1-8.

[5] Ramaraj, A.P., Jagannathan, R. and Dheebakaran, G., 2009, Impact of climate change on rice and groundnut yield using PRECIS Regional Climate Model and DSSET crop simulation model. ISPRS Archives XXXVIII-8/W3 Workshop Proceedings: Impact of Climate Change on Agriculture. ISPRS Ahmadabad, Space Applications Centre (ISRO):17-18.

[6] Sarabdeep, K., 2008, Contribution of agriculture to GHGs effect. Rashtriya Krishi. Vol. 5(2):126-127.

[7] Sinha, S. K., Swami Nathan, M.S., 1991, Deforestation, climate change and sustainable nutrition security: A case study of India. Climatic Change. Vol. 19: 201-209.

[8] Thorup-Kristensen, K., Magid, J., Jensen, L. S., 2003, Catch crops and green manures as biological tools in nitrogen management in temperate zones. Advances in Agronomy. Vol. 79: 227-302.



## AGRICULTURAL WASTE AWARENESS AND UTILIZATION FOR HEALTHY ENVIRONMENT AND SUSTAINABLE LIVELIHOOD

P. S. SHEHRAWAT, Nitu SINDHU, Parmila DEVI

Choudhary Charan Singh Haryana Agricultural University, Department of Agricultural Extension, Hisar-125004, India, Mobile: + 91 94161, Fax +91 1662 234952, Email: psshehrawat1965@gmail.com

**Corresponding author:** psshehrawat1965@gmail.com

### Abstract

*The result have shown that majority of the farmers were of middle age group (36-50 years), educated up to metric, belonged to joint family with 4-6 members, performed only farming and had land holding up to 5 acres. Result pertaining to awareness indicated that awareness about the utilization of biogas plant waste, mushroom waste, wheat waste, mustard and horticultural waste was more than 70 percent. Awareness about utilization of paddy waste, sugarcane waste, cotton waste, floricultural wastes, poultry waste and livestock waste was between 50 to 60 percent. Thus, overall awareness about utilization of agricultural waste was very high. The result revealed that utilization of agricultural waste by the farmers was very less. None of the farmers exploited the wastes fully; waste utilization of wheat, paddy, sugarcane cotton and mustard crop, horticultural crops and floricultural crops was very low. Waste utilization of mushrooms, livestock and poultry was medium and biogas waste utilization was high. The result showed that there was a huge gap between the awareness and utilization of agricultural waste. The farmers must understand that there is nothing waste in agriculture, everything can be converted into something useful.*

**Keywords:** agricultural-wastes, awareness, healthy environment and sustainability, utilization

### INTRODUCTION

Agricultural wastes are unusable substances that may be either liquid or solid produced as result of cultivation processes such as fertilizers, pesticides, crop residues and animal waste. Agricultural waste management is part, of the ecological cycle in which everything is cycled and recycled such that an interdependent relationship is maintained in the eco-system. Waste management places all the plant wastes placed at the right place and right time for the best utilization in order to convert into useful products and pollution control. Globally, 140 billion metric tons of biomass is generated every year from agriculture. Ministry of New and Renewable Energy, Govt. of India estimated that about 500 Mt of crop residue is generated every year. These wastes are destroyed by burning or allowed to decay in public places in the open air creating environmental pollution. Thus by managing

crop wastes in a well-planned manner, we can maintain a healthy environment for ourselves and all other living creatures. This study will highlight some of the trends that

could be adopted in the agricultural waste management so that the farmers become aware and take full advantage of the various possibilities of plant waste cycling, recycling and further utilization for economic purpose.

### MATERIALS AND METHODS

The study was conducted in two districts of Haryana state, Hisar and Sonapat, purposively selected. Further six villages were selected randomly, ten farmers were selected randomly from each village, and thereby a total number of 120 farmers having multiple cropping systems were interviewed for the study.

### RESULTS AND DISCUSSIONS

**Personal profile of the farmers:-** Personal profile of the farmers indicated that most of the farmers were from middle age group (36-50 years), were educated up to metric, belonged to joint family of medium size with 4-6 members. Majority of the farmers had their main occupation as farming and land holding up to 5 acres. Among mass media exposure, utilization of newspaper among the

farmers was maximum followed by TV, radio, kisan seva Kendra and magazine. The extent of utilization of newspaper, radio and T.V. was daily and magazine and kisan seva Kendra was often. Out of 120 farmers only 55 (44.85 percent) farmers underwent training or workshop related to management of their waste. Among the contacts with extension officials, maximum contact of farmers was with progressive farmers, followed by scientist, ADO (Agricultural Development Officer), SDAO/SMS (Sub Divisional Agricultural Officer)/ Subject Matter Specialist and NGO. The frequency of contact with progressive farmers and scientists was weekly, ADO and SDAO/SMS was whenever needed and monthly with NGO (Table 1).

Table 1. Profile of the respondents.

S. No.	Variable(s)	Category	No. of Respondents	Percentage (s)
1	Age (years)	Middle (36-50)	60	50.00
2	Education	Metric	43	35.83
3	Family type	Joint	85	70.83
4	Family size	Medium (5-6 members)	48	40.00
5	Occupation of respondent	Only farming	98	81.67
6	Land holding	Up to 5 acres	36	30.00

**Facilities available with the farmers**

Facilities available with the farmers either personal or public, the study indicated that only 63.33% of farmers could easily avail to laborers/manpower, 39.16 % of farmers had transport facility for waste, 42.50% of farmers had personal composting units, 34.17% farmers had personal biogas plants, only 8.33% of farmers had the facility of community waste collection centres and farmers did not have any common waste dumping sites or block making machine in their villages.

Table 2. Facilities available with the farmers.

S. No	Particulars	No. of Respondents	Percentage
1	Compost plant	51	42.50
2	Transportation facility for waste	47	39.16
3	Biogas plant	41	34.17
4	Community waste collection centre	10	08.33
5	Common waste dumping site	0	00.00
6	Block making machine	0	00.00

**Awareness among the farmers about the products made from agricultural wastes**

Awareness: awareness among the farmers about the utilization of agricultural waste was noticed to be very high. The result was apposite as the farmers were well educated and had regular mass media contact. Radio and TV were the most common and easily accessible source of agriculture information for farmers including contact and non-contact groups [1]. Farmers had regular contact with extension officials and often visited to KVKs, and ATIC is performing excellent role of information spread [9].

One hundred twenty farmers from two districts of Haryana state, namely, Hisar and Sonipat were interviewed. It was observed that 100 percent farmers were aware regarding the use of agricultural waste to make animal feed, biogas, animal shelter and its use as energy source. Awareness regarding making compost, vermin compost and organic manure was found 97.50 percent. Awareness about making poultry litter was 96.67, for generating electricity was 90.00 percent, mulching and handicrafts was 85.00 percent, making beauty products was 80.83 percent, paper, cardboard and particle board was 75.83, making briquettes was 52.50, planting bed was 51.67 and awareness about making chemicals was 40.00 percent. Low percentage of awareness was noticed regarding making activated carbon (29.17 percent) followed by Bioplastics (24.17 percent), textile fibre (20.83 percent) and utensils 00.83 percent (Table 2).

**Overall awareness about the utilization of agricultural wastes**

The overall awareness among the farmers about utilization of different crop waste is presented in the figure 1. The figure clearly describes the awareness about the utilization of different crop waste. Awareness about utilization of wheat straw was 72.33 percent and paddy waste was observed 63.94 percent. Awareness about utilization of sugarcane waste was 62.73 percent. Awareness about utilization of cotton sticks was 61.33 percent and about utilization of mustard sticks was observed 70.08 percent.

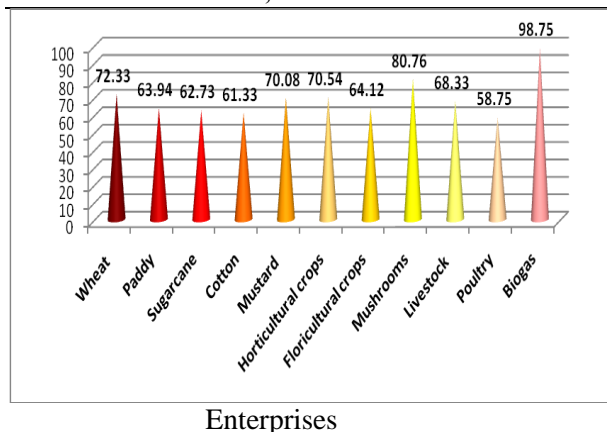

Fig.1.Overall awareness about utilization of agricultural wastes

Awareness about utilization horticultural waste was 70.54, about utilization of floricultural waste was 64.12, utilization of mushroom waste was 72.50 percent, utilization of livestock waste, biogas plant waste and poultry was 68.33, 98.75 and 58.75 percent, respectively (Figure 1).

#### Utilization of different agricultural wastes

**1. Paddy waste:** From paddy crop, the byproducts or residues are paddy straw, paddy husk and farmers are utilizing rice bran but only paddy straw. Sixty seven farmers cultivated paddy crop and all of them stored it for future use as animal feed and for making animal bed and shelter (100.00 percent), about 82.08 percent farmers sold it, 77.61 percent use it for mulching purpose, 56.72 percent used it for composting and vermicomposting and only 1.47 percent farmers used it for fuel purpose. Paddy straw can be used as a source of energy for in small-scale processing units, for carrying out various processes like washing, boiling, canning, etc. A mushroom processing unit is being run by a farmer in village Aterna of district Sonipat, his processing unit works under biomass energy. Paddy straw, cotton sticks, mustard sticks and husk is utilized as a source of energy in the processing unit.

**2. Wheat waste** Straw is a byproduct of wheat crop. Wheat straw can be used for making many products but all the farmers store it and use it for animal feed and 57.50 percent farmers sell wheat straw as feed for animals. It was reported that, 81.67 percent farmers are aware that wheat straw can used for making particle board but neither they sell

wheat straw to particle board industries nor they utilize it to make other products like briquettes, dry flowers, hats, mats, carpets and other handicrafts. Similar results were found that particle board can be made with crop residues mixed with wood from *pinus radit*, all the crop residues like wheat straw, corn and rice straw are suitable for making particle boards but best results were with wheat straw and corn stubbles[4]

**3. Sugarcane waste** From sugarcane crop, residues are sugarcane trash and bagasse. From the farmers those who cultivated sugarcane (43 farmers), 48.83 percent used the bagasse as fuel in making jaggery, 46.51 percent turned it into compost/vermicompost and only 11.62 percent sold it to paper/cardboard industry or power plant. Farmers used sugarcane trash to feed their animals (100.00), composting/vermicomposting (46.51), sell as animal feed (16.28) and use it for mulching (1.67). Apart from composting and feeding bagasse and trash to animal, bagasse can also be used as planting for growing green fodder. Beside this sugarcane bagasse has one more important use which is production of biogas; this is similar to the findings of [3], who conducted the study due to the existing difficulty of finding energy sources and reducing pollution, the use of renewable sources and highly efficient technologies for electrical energy production, the combination of these two aspects, namely, a molten carbonate fuel cell system fed with biomass derived syngas. In particular, the biogas comes from bagasse and barbojo, the sugarcane residues. So far, in developing countries they have been wasted or partly used with poorly efficient technology.

**4. Cotton waste** Seventy-five farmers cultivated cotton crop. Cotton sticks, which are left after the picking of cotton, are used as fuel and stored by all the farmers. Cotton sticks were not utilized for any other purpose. If the farmers sell the cotton sticks to power plants, plywood industries, particle board industries they can add to their income. Another way of changing the waste cotton sticks into useful material is by chipping and converting them into compost. Cotton waste

can also be used in biogas production by treating it anaerobically. This was similar to the findings of [5], who found out that cotton wastes are a good source of biogas. Approximately 65, 86 and 78 ml CH<sub>4</sub> were produced in 23 days from 1 g of cotton stalks, cotton seed hull and cotton oil cake in the presence of basal medium (BM), respectively. BM supplementation had an important positive effect on the production of biogas.

**5. Mustard waste** Mustard was cultivated by 102 farmers. Mustard sticks and husk are two major byproducts from mustard crop. Mustard sticks and husk are sold to brick industries by all the farmers who cultivate it (100.00), 90.19 percent farmers stored it for future use, percent 73.52 percent used it for burning in chulha and only 16.66 percent farmers use it for composting. A profitable way of managing mustard sticks is chipping and composting or feeding to animals after treating with ammonia. Another important material, which can be made from mustard sticks are briquettes. Mustard stalk, mixed waste of tree leaves and grasses in 3:1 proportion and wood waste along with three organic binding materials (molasses, press mud and distillers dry grain) with varying concentration of 5, 10, 15 and 20% can be used for preparing briquettes. Press mud was is a better binding agent, followed by distiller's dry grain and molasses. This was similar to the finding of the result by [2] who reported the physical characteristics like moisture content, bulk density, compression ratio and compressive strength desired for better utilization and safe handling and transportation are found to be best for briquettes made from press mud and mustard stalk at die pressure of 123.42 MPa.

**6. Horticultural waste** Horticultural crops were cultivated by 64 farmers. Damaged or spoiled fruits and vegetables, dead plants, branches, leaves and unsold fruits and vegetables are the horticultural wastes. Among these damaged fruits and vegetables are turned into compost/vermicompost or fed to animals by 70.31 percent of farmers. The dead plants, branches and leaves were fed to animal by 100.00 percent and composted by 70.31 percent of farmers. Unsold fruits and

vegetables are fed to animals by 100.00 percent, composted by 70.31 percent, and 26.56 percent farmers sold it after processing. Value added products can be made from surplus fruits and vegetables and then sold in market this will not only help the farmers avoid wastage but to earn more. Another way of preserving the unsold fruits and vegetables is drying them and then selling. Various chemical can also be extracted from waste fruits and vegetables like citric acid, lactic acid, acetic acid, etc. Manoj et al. (2012) that it can be produced through the batch & fed batch fermentation method using hydrolyzed potato starch, results from the findings of [10] concluded that potato residues could also be used for extraction of pectin-studied production of Lactic acid.

**7. Floricultural waste** Flowers were cultivated by only 14 farmers. After picking of flowers, the whole plant is a waste along with the damaged and unsold flowers. The left flowers are generally sold at least price by 100.00 percent of farmers, used in composting, vermicomposting and green manuring by 71.43 percent of flowers. The dead plants and waste flowers are used either in composting, vermicomposting or in green manuring by 8.33 percent of farmers. The left out flowers can be dried and powdered and cut flowers can be used for making dry flowers, which is an upcoming industry. The dry-flowers can be painted, coloured, dyed and various floral products such as cards, pictures, wall hangings, arrangements, pot-pouris and pomanders can be prepared out of them.

**8. Mushroom waste** Mushrooms are produced on natural materials taken from agriculture, woodlands, animal husbandry, and manufacturing industries. After mushroom crops are harvested, millions of tonnes of "spent" (used) mushroom substrate become available for other uses. The used growing medium is far from spent. It is clear from table 25 that; it is used as manure, for gardening, for making nurseries and growing vegetables by all the farmers those who grow mushrooms use the waste mushrooms for composting and vermicomposting, 16.67 percent farmers fed it to animals and used for

biogas generation. The spent compost was used for vermicomposting, manuring and planting bed by 100.00 percent of farmers. Surplus mushrooms were sold at least price by all the farmers and sold after processing by 33.33 percent of farmers. Another way of handling spent substrate from *Agaricus bisporus* production is relevant with the study conducted by [8], which is already in wide use in horticulture as a component of potting soil mixes; in agriculture or landscape trades to enrich soil; as a casing material in the cultivation of subsequent *Agaricus* crops, in vermin culture as a growing medium, in wetlands for remediation of contaminated water, in stabilizing severely disturbed soils, in the bio-remediation of contaminated soils, as a bedding for animals, as an animal feed, and to control plant diseases. Spent substrate from other mushroom species has found acceptance as food for animals, as ingredients in the cultivation of other mushroom species, as fuel, as a medium for vermin culture, to enrich soils, and as a matrix for bio-remediation.

**9. Biogas plant waste** Forty-one farmers possessed biogas plant. The farmers (100.00) as manure and for composting and vermicomposting by 78.04 percent of farmers utilize slurry thrown out of the biogas plant. This result was analogous with the findings of [7] that vermicompost can be used as manure on farm, the application of FYM + vermicompost @ 2.5t/ha along with the panchagavya 3% proved to be the best treatment as it was found to record the highest plant height (83.17cm), no. of branches (38.23) and leave (1115.87) and also recorded the mass herbage (44.81g/plant).

**10. Livestock waste.** Livestock was owned by all the farmers. All the farmers used the waste to make dung cakes this was relevant to the study conducted by [6], who reported that in Haryana all the farmers make dung cakes daily and the problems faced by the respondent in procurement of fuel were time constraint health and drudgery psychological and lastly economical problems. Only 34.17 percent of farmers used to generate biogas, 42.5 percent farmers used it for composting/vermicomposting and only 1.67

percent farmers used it for making bio insecticide. Currently the energy consumption is rising and there is need of an alternate energy source, this problem can be solved by utilizing the agriculture biomass for generating energy. Major agro-industrial wastes, animal farm waste and municipal solid waste were sources of biogas feedstock in biogas technology. Thus, a better way of producing clean energy is biogas technology.

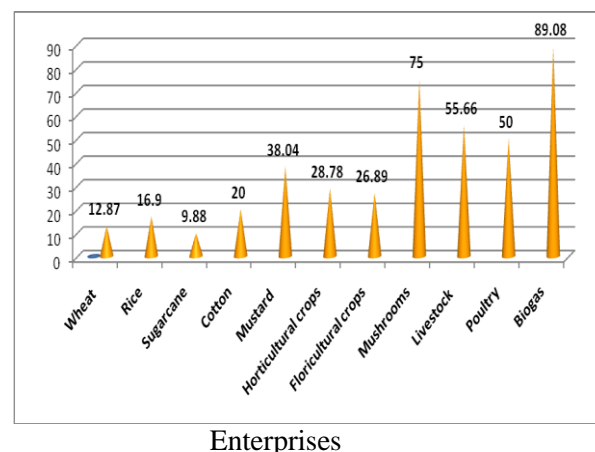

Fig.2. Overall utilization of various agricultural wastes

**Gap between awareness and utilization of agricultural wastes**

The huge gap between awareness and utilization is shown in the figure 3. The awareness about the utilization of wheat waste was 72.33 percent and utilization of wheat waste was 12.87 percent. Awareness about utilization of paddy waste was 69.94 percent and utilization was computed as 16.90 percent, awareness about utilization of sugarcane waste was 62.73 percent and utilization was 9.88 percent, awareness about utilization of cotton waste was computed as 61.33 percent and utilization as 20.00 percent, awareness about utilization of mustard waste was 70.08 percent and utilization was 38.04 percent, awareness about utilization of horticultural waste was computed as 70.54 percent and utilization was computed as 28.78 percent, awareness about utilization of floricultural waste was 64.12 percent and utilization was computed as 26.89 percent, awareness about utilization of mushroom waste was 80.76 percent and utilization was 75.00 percent, awareness about utilization of livestock waste was 68.33 percent and



utilization was 55.66 percent, awareness about utilization of poultry waste was 58.75 percent and utilization was 50.00 percent and awareness about utilization on of biogas waste was computed as 98.75 percent and utilization was 89.08 percent (Figure 3).

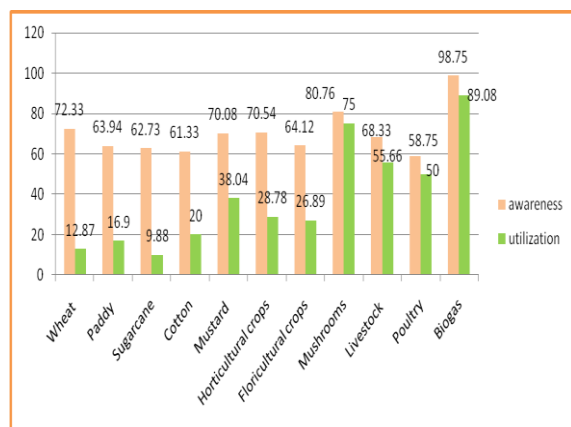

Enterprises

Fig.3. Gap between awareness and utilization

## CONCLUSIONS

The study revealed that there was a huge difference between the awareness and utilization of agricultural waste. This difference existed due to lack of interest among the framers. Thus there is need to motivate farmers which can be made possible by organizing trainings, lectures, showing films to farmers or demonstrating waste management techniques on field.

## REFERENCES

- [1]Ahemad Ajaz, Tripathi Raj Bahadur, 2009,The effective information sources for contact and non-contact farmers under T & V system of extension in Kashmir. *Asian Journal of Home Science*,Vol. 4(1): 64-66.
- [2]Andrade, A. M., Duarte, A. P. C., Belgacem, M. N., Munaro, E. R, 2001, The Production of handmade papers with mixtures of recycled fibres and virgin fibers of bamboo (*Dendrocalamus giganteus*) and sugar-cane bagasse (*Saccharum officinarum*) *Floresta-e-Ambiente*, Vol. 8(1):143-152.
- [3]Dellepiane, D., Bosio, B., and Arato, E. 2003, Clean energy from sugarcane waste: feasibility study of an innovative application of bagasse and barbojo. *Bio Resource Technology*, Vol. 73(2): 95-98.
- [4]Garay, Rose., Marie, MacDonald., Francisco, Acevedo., Maria, Luisa., Calderon, Beatriz and Araya, J. E. 2009, Particleboard making with crop residues mixed with wood from *pinus radiata*. *Bio Resource*,

Vol. 4(4):1396-1408

[5]Isci, A., Demirer, A., 2006, Biogas production potential from cotton wastes. *Renewable Energy*. Vol. 32(5):750 -757.

[6]Mehta, M., Sangwan, V., Malaviya, A., 2002, Fuel use pattern in rural Haryana. *Journal of Family Ecology*. Vol. 4 (1&2):54-59

[7]Ponni, C., Arumugan Shakila, 2007, Effect on certain organic manures and Bio-stimulants on the growth, yield of *phyllanthus niruri*. *The Asian Journal of Horticulture*. Vol. 2(2):148-150.

[8]Rinker, L. D., 2002, Handling and using spent mushroom substrate around the world. *Mushroom Biology and Mushroom Product*:43-60

[9]Shaikh, N.V., Ahire Milind, C., Sonawane, H.P., 2007, ATIC-A system of technology. *Journal of Community Sciences*. Vol. 25:81

[10]Zhahg, Chunpeng, Taihu, 2011, The optimization of pectin extraction from sweet potato residues with disodium phosphate solution by response surface method. *Engineering and Environment of Bio systems*. Vol. 46:2274-2280



## THE STRATEGIC MANAGEMENT AS A PRIMORDIAL FACTOR TO OBTAIN PERFORMANCE IN AGRONOMIC HIGHER EDUCATION IN REPUBLIC OF MOLDOVA

**Adrian SÎRBU**

The State Agrarian University of Moldova, 44, Mircești, Chișinău, Republic of Moldova, Phone: + 373 22 432 395, E-mail: a.sirbu@uasm.md

**Corresponding author:** a.sirbu@uasm.md

### **Abstract**

*In this article we perform an analysis of the key aspects of strategic management which is one of the main factors that have a direct impact on obtaining performing results or nonperforming results of teachers in the agronomic higher education in Republic of Moldova. Directly, will be highlighted the aspects of the concept of organizational strategy, the guidelines and the approaches of strategic management at all hierarchical levels of agronomic higher education in Republic of Moldova. The same will be highlighted aspects of the basic functions of agronomic higher education institutions in Republic of Moldova, and aspects of organizational culture and at the same time which is the situation of innovation and introduction of new advanced technology necessary for obtaining performing results with the aim of creating a highly competitive environment of these institutions at national and why not international level.*

**Key words:** agronomic higher education, agricultural research institutions, competitive, management, objectives, performance, pillars, strategy

### **INTRODUCTION**

Competition in the market economy requires intensive use of existing resources - financial, material, technological, human, information etc.

Therefore, any organization - economic or institutional type, involves in the current information society, solving the needs of knowledge, which is based on strategies, principles, methods and modern investigation techniques, planning and organization.

Agronomic higher education and research institutions being characterized by different types of organization, coordination and planning resources, they need in today's conditions of information society, of new knowledge that is based on the strategies, principles, methods and modern investigation techniques, planning and organization.

All these have become possibilities of managers due to the development of information technology especially necessary for substantiation of decision.

### **MATERIALS AND METHODS**

We will surprise you in this article, an

analysis of the essential ingredients of management's strategic elements, techniques and methods of identifying performing and competitive strategies of the institution of agronomic higher education and research institutions. In order to obtain a success in the era of globalization for contemporary and future professional life, taking into the alternative analysis of the effects that it has in offer services to higher agronomic education institutions quality.

The work is developed based on empirical research using the formulation of hypotheses, construction of systems theory and observation instrument. The research is also based on theoretical and scientific support using statistical methods and comparative.

### **RESULTS AND DISCUSSIONS**

The term „strategy” comes from the Greek word „Strategya”. This term was first used by the Greek army and signifies a group of activities related to the preparation and execution of the fight to ensure victory.

The French have taken the term „stratégie” also in the army with the same signification.

Table 1. The main features of performance and realistic strategies awarded to an institution of higher agronomic education and research in the country.

The content of strategy	The specific feature of
- Achievement of objectives of a strategic mission.	The objectives represents motivational basis of the strategy and action, their quality being decisive for future performance of the institution.
- The periods in the life of an institution	Usually 3 - 5 years. It follows the high degree of risk and uncertainty.
- The strategy characteristics	It summarizes the essential elements, major, for the institution.
- Activity	The whole institution, agronomic higher education institution as a whole. Even when it relates directly to certain departments, it is based on consideration of the overall problems of the institution
- The existing environment	It is always considered the external environment of the institution and provides a very strong correlation between agronomic higher education institution and environment in which it operates. This is a feature and a condition for the success of the strategy; realization of strategic objectives is not possible without taking into account the evolution of the external environment.
- The interests involved.	It is always represented the interests of all parties involved in the educational process, the rector, vice-rectors, deans, heads of departments, teachers until the students.
- Behavior of the parties	You have to consider imposition of a behavior which will ensure higher education institution agronomic greater competitiveness. This behavior reflects the culture of the institution, expressing attitudes, believes attachments, aspirations and values of managers and executors.
- The competitive advantage.	A strategy that does not concern and ensures obtaining the competitive advantage does not present utility for a higher education institution and agronomic research

Source: Own calculation.

By the middle of twentieth century the term was taken and used by American companies on the assumption that in business „any market is a war” and the competitive battle to secure the survival and development of an organization should be based on a strategy.

Any strategy must provide the framework and the general coordinates of development and the future efficiency of an institution. The quality of the agronomic higher education and research institution depends on its degree of realism. In a realistic strategy and

performance the necessity of the main specific features which are considered the most important and are presented in Table 1.

Respecting and incorporating all the features of a performance strategy in agronomic higher education and research institutions will increase the competitiveness of both the institution as well as the state.

The term of competition has theoretical connotations, but also practical aspects. We will approach the competition and its result, competitiveness, of the competitor position. The features considered to provide better grade, can be classified into two categories: the effect (maximum) or effort (minimum).

Encyclopedic Dictionary defines the competitiveness as a characteristic of a product or a company to cope with the competition of similar products or companies in a particular market, or structural competitiveness which appreciates the degree of specialization of a country or structural competitiveness appreciates the degree of specialization of a country so that to be assured a surplus or a durable trade balance.

Through coverage rate of exports and coefficient of specialization. This definition represents a viable point of view for identifying specific ways to improve competitiveness in a particular field. [7]

If we look at the conceptual approach of the Global Competitiveness Report - RGC (Global Competitiveness Report - GCR), published by the World Economic Forum, which defines, „competitiveness” as „a set of institutions, policies and factors that determine the level of productivity of a country” organized into 12 basic pillars, directly systematized for Republic of Moldova, reference year 2014, as follows, and are outlined in table 2. [5]

If we refer to the 12 pillars that contribute to competitiveness, we note that „technology” places us in position 64, being the highest position of the state in this classification, in accordance with this there is also just „macroeconomic stability” which is positioned on 77 places. It emphasized that „institutions”, „efficient on the market” and „financial market”, „market size”, „business

sophistication” and „innovations” are located on 105 place, context where „technology” and „macroeconomic stability” is already a major performance.

Table 2. The position of Republic of Moldova in 2014, on pillars that contribute to the competitiveness

Basic requirements	Position	Efficiency enhancer	Position	Innovation and sophistication factors	Position
1. Institutions	122	5. Higher education and training	90	11. Business sophistication	125
2. Infrastructure	88	6. Goods market efficiency	107	12. Innovation	138
3. Macroeconomic environment	77	7. Labor market efficiency	95		
4. Health and primary education	93	8. Financial market development	105		
		9. Technological readiness	64		
		10. Market size	124		

Source: Own calculation.

Table 3. Institutions of agronomic higher education and research in Republic of Moldova

Agronomic higher education institutions (Legal address)	Agronomic research institutions (Legal address)
The State Agrarian University of Moldova (44 Mircești, Chișinău, Republic of Moldova)	Practical Scientific Institute of Biotechnology in Animal Husbandry and Veterinary Medicine. (rayon. Anenii Noi, s. Maximovca)
Technical University of Moldova. (168, Stefan cel Mare Blvd., MD-2004, Chisinau, Republic of Moldova)	Research Institute of Field Crops „Selectia”. (28, Calea Ieșilor, Balti, Republic of Moldova)
Moldova State University (str. Alexe Mateevici, 60, Chisinau, MD-2009, Republic of Moldova)	Institute of Crop Production „Porumbeni”. (rayon. Criuleni, s. Pascani)
Moldova State University of Comrat (17, Galatana, Comrat, Republic of Moldova)	Institute of Soil Science, Agrochemistry and Soil Protection „Nicolae Dimo”. (100, Ialoveni, Chișinău, Republic of Moldova)
“Alecu Russo” State University of Balti (38, Puskin, Balti, Republic of Moldova)	Institute Scientific - Practical Horticulture and Food Technology. (59 str. Vierul, city Codru, Chișinău, Republic of Moldova)
	Institute of Agricultural Technique Institute (ITA) „Mecagro” (The Republic of Moldova, Miron Costin 7, Chișinău)
	Institute of Microbiology and Biotechnology of the Academy of Sciences of Moldova. (mun. Chișinău, str. Academiei, 1)
	Institute of Zoology, Academy of Sciences of Moldova (mun. Chișinău, str. Academiei, 1)
	The Institute of Genetics and Plant Physiology of the Academy of Sciences of Moldova (mun. Chișinău, str. Pădurii, 20)
	Institute of Plant Protection and Ecological Agriculture. (26/1, Pădurilor, Chișinău, Republic of Moldova)

Source: Own calculation.

Somewhat paradoxically, the ability of selling „labor market” have position 95 and „health and primary education” have position 93 and „higher education and training” on 90, although under the requirements and potential, but are quite good.

Analyzing the 12 pillars of competitiveness we highlight the major importance of strategic management that assumes an approach coherent of internal and external factors which affect agronomic higher education institutions

and research and hence the elaboration and implementation of rigorous and explicit strategies to enable institutions of agronomic higher education and research to reflect the susceptible changes to occur in the environment, to enable them to survive and adapt to new market conditions. [8]

Table 4. 5 key areas for establishing objectives awarded research activities, education and innovation in agronomic higher education and research in the country.

Domain - Key	The characteristic domain
- Physical and financial resources.	It needs to establish specific objectives for the rational use of physical resources materials and capital by agronomic higher education institutions and research.
- Performance management and development.	It should be set goals for developing present and future managerial talent in agronomic higher education institutions and research.
- Performance and attitude of teaching and research staff.	Objectives must be set on the performance and attitude of employees who have leadership positions;
- Innovation	Must be observed all requirements concerning quality, which is a key to success must set goals for improvement, development and improvement in terms of academic Curriculum, teaching methods, learning and innovation for students and master the material presented in many specialties and specializations that are exposed by agronomic higher education institutions;
- Public responsibility (social).	All higher education institutions must determine agronomic limit to be involved in various activities involving directly service of the interests of all citizens in society.

Source: Own determination.

The strategic dimension of agronomic university management and research should be ensured by the existence of strategic thinking and a positive organizational culture change and performance in a competitive and competitive external environment. All of agronomic higher education institutions and research practice directly impacts on the 12 pillars of increasing the competitiveness of Republic of Moldova are presented in Table 3. [6]

To achieve the objectives, agronomic higher education institutions and research from Moldova should perform a set of activities and actions. The stages of effective realization of the objectives are numerous; respectively university management must take a clear decision-making series actions, opportune and efficient in terms of how to achieve strategic

objectives. Strategy of agronomic higher education institutions and research represents the result of strategic choice of top university agronomic management on the ways they will follow the alternative means that they will use to achieve the objectives submitted.

During the development of human society, there have been numerous attempts to identify areas for which an organization must set goals; the known list of key areas was made by Peter Drucker. [2] Which identified eight key areas for setting goals across the organization, the organizations which aim making a profit much as possible, of course, if we are talking about commercial, manufacturing, service delivery and so on instead if we talk about non-profit organizations such as higher education and agronomic research we can identify the five key areas for establishing objectives directly related to research, education and innovation in these institutions, which are presented in Table 4. [1]

The role of the objectives is to produce change. They should cover all important aspects of labor (the main areas of result) and not just focus on one area or aspect at the expense of others. It is very important that objectives are SMART.

SMART is an acronym of the features considered essential for the correct formulation of a goal. The most common versions of the acronym SMART are:

S: Specific / Applicant - means that an object must be clear and unambiguous, easy to understand and apt to require existing potential;

M: Measurable - means that an object can be quantified: quantitative, qualitative, in time, in money. A measurable objective is the one „that allow the establishment exactly that has been reached or not” or „what extent was reached”. It also allows a measurable objective of achieving progress monitoring;

A: Adorable - means that an object can be difficult, but not impossible to reach by a competent person and decided to take a conscious engagement;

R: Relevant - means that contributes to achieving the overall objective so that specific

goal is aligned overall goal;

T: Temporal – sized in time that is achieved within a time limit of commonly agreed. [3]

In addition to those five basic objectives we consider it will opportunely to complete two significant objectives when deciding future development strategy within an institution of higher education and agronomic research, and respectively acronymic could be:

SMARTER. Respectively:

E: Efficient - means that achievement of the objective should aim at enhancing and rationalization of all activities and processes within the institution which will mean that objective;

R: Regulatory - the target should be within the legal parameters, to respect current legislation on the activities of the institution which will address this objective.

Strategic management is a modern form of management of agronomic higher education institutions and research, based on anticipating change of the environment, on evaluation of the internal potential of agronomic higher education and research the changes that are necessary in order to harmonize with the environment to which they belong, to performance of the tasks and objects set to ensure its survival and sustainability.

In other words, strategic management represents a quite complex process foreshadowing the future of agronomic higher education institutions, their long-term evolution in which occurs in strategy formulation, implementation and monitoring-evaluation of her permanently strategic management is not just a process of strategy formulation (which overlaps institution management system), but a new form of management based on strategy. [7]

## CONCLUSIONS

Through the implementation and management of qualitative strategic management in agronomic higher education institutions and research will be obtained a number of long-term benefits related to:

1. Adaptation of agronomic higher education

institutions and research, of rapid environmental changes, anticipating them or even their generation;

2.Generation of routing long-term agronomic activities of higher education institutions and research;

3.Allowing a consistent and accurate correlation of all agronomic higher education institutions activities and research;

4.Providing a coherent framework for action at all hierarchical levels of management;

5.The production of modifications in concept, attitude and action of top management;

6.Permanent involvement of all decision makers, at all hierarchical levels;

7.Agronomic higher education institutions and research will receive its own identity;

8.Agronomic higher education institutions and research will become more efficient and competitive. [9]

The practice of strategic management produces within an institution of agronomic higher education and research a number of changes terms of its conception, climate, its functioning mechanisms, with beneficial effects on the performance and competitiveness of these institutions.

The practice by an institution of agronomic higher education and research strategic management allows them to acquire the competitive advantage or herself compared competitors offer. [4]

The link between strategic management and competitive advantage is explained by the that the strategy always involves innovation process, either in terms of university management, human resources, information technology, financial resources and the material existent in the institutions of agronomic higher education and research, where the possibility of a competitive advantage. Therefore, as long as the strategy involves the use of innovation in one area or another, strategic management allows assimilation of competitive advantage. [7]

Competitive advantage can be temporary (when capitalize a temporary opportunity or a favorable environment) and durable (it can be sustained for a long period of time). In conclusion, the competitive advantage is

invisible component of the strategy gives ultimately, sustainability and competitiveness of agronomic higher education institutions and research in the long term. Competitiveness is the best way to improve permanent performances. Being the essence of progress, it stimulates permanently set standards of quality, increases the number of graduates in agronomic higher education institutions, support innovation, research and perfection. [7]

## ACKNOWLEDGEMENTS

This research work was carried out with the support of The State Agrarian University of Moldova.

## REFERENCES

- [1]Cornescu V., Marinescu P., Curteanu D., Toma S., 2003. Management, de la teorie la practică. București, 35-37.
- [2]The Practice of Management. 1974, New York, McGraw-Hill, p. 44
- [3]www.anssa.ropublicatii.doc
- [4]www.inventica.usm.md
- [5]http://www3.weforum.org
- [6]http://lex.justice.md/viewdoc.php?action=view&view=doc&id=351253&lang=1.
- [7]http://ebookbrowse.net/c-3-315-management-strategic-petrovici-virgil-doc-doc-d423963067.
- [8]http://cursdeguvernare.ro
- [9]www.steconomie.uoradea.roanalevolume2006management-si-marketing44.pdf



## RESEARCH ON THE ECONOMIC DEVELOPMENT OF SOUTH-WEST OLTENIA REGION

Elena SOARE<sup>1</sup>, Iuliana DOBRE<sup>2</sup>

<sup>1</sup>University of Agricultural Sciences and Veterinary Medicine of Bucharest, 59 Mărăști Blvd, District 1, 011464, Bucharest, Romania, Phone: +4021.318.25.64, Fax: + 4021.318.25.67, Email: soare.elenausamv@gmail.com

<sup>2</sup>Bucharest-Academy of Economic Studies, 5-7 Mihail Moxa Street, Bucharest, Romania, Code 010961, Phone:0213119790/112, Email: iulya\_dobre@yahoo.com

**Corresponding author:** soare.elenausamv@gmail.com

### Abstract

*Within this scientific paper is being analyzed the economy of South-West region of Oltenia, in Romania. This analysis highlights an evolution of certain indicators such as: regional gross domestic product; gross domestic product per capita; number of active companies; the staff in active local units; turnover in local active companies; gross and net investments. South-West region of Oltenia recorded a percentage of 12.3% of the country's total surface and at the same time, it has numerous landforms, along with a variety of natural economical resources. This area is both specialized in producing thermo and hydroelectric energy and in agriculture, using large plots of land. Nowadays, one could observe an increase of inter and intraregional disparities. There must be attracted massive investments all over this region in order to reduce unemployment rate. In this paper there are being introduced the main economic indicators, estimated from 2015 to 2017. In order to realize this scientific paper, there have been used data given by the National Institute of Statistics and by the National Committee of Prognosis.*

**Key words:** gross investments, regional gross domestic product, South-West region of Oltenia, turnover in local active units

### INTRODUCTION

South-West region of Oltenia consists in five counties and registers almost 12,3% of Romania's total surface. This area presents different landforms and has numerous natural resources such as: gases; coal; oil; salt; wood; mineral and thermal springs and so on. The South-West region of Oltenia has a considerable area for agriculture, but the productivity within this sector is quite reduced because there are not being used efficient equipments and developed technologies [7]. The main areas of economic concentration within South-West region of Oltenia are:

- Craiova- automotive industry and machine building one;
- Slatina- metallurgical industry;
- Râmnicu Vâlcea- chemical industry;
- Târgu Jiu- extractive industry;
- Drobeta Turnu Severin- energetic industry.

The capacity of attracting investments in this area is quite reduced, leading to a low rate of employment [11].

### MATERIALS AND METHODS

In order to realize this scientific research there were used certain indicators for characterizing the economic development level within the South-West region of Oltenia, as following: Gross Domestic Product; Regional GDP per capita; GDP by resources categories; the number of active companies; staff in local active units; turnover in local active companies; gross investments and net ones. The present research was based on data given by the National Institute of Statistics and the National Statistical Commission. With an eye on realizing a research that could picture the dynamics of South-West region of Oltenia economy, there was consulted a series of recent studies, specialized magazines; newspapers and specialized books.

### RESULTS AND DISCUSSIONS

The dynamics of economy in South-West region of Oltenia, during the analyzed period of time, was influenced by a whole series of

internal and external factors. In this context, it is necessary to remember Romania's integration in the European Union (2007) and also, the economic and financial crisis (2008). In order to develop this area, it was overwrought a Strategy of Oltenia Region for 2007-2013. The main objective of this strategy was represented by gaps reduction in comparison with other areas in Romania. Reducing disparities would directly lead to an increase of living standards in this region [9]. It is required to remember certain factors that determine the economic development at regional level, such as: current labour force and work productivity; level of capitalization; the usage of efficient technologies; distance

compared with other markets; facilities granted to entrepreneurial sector and so on [3].

The development level of a certain area is determined with a representative indicator, the Gross Domestic Product [6]. The dynamics of GDP within the South-West region of Oltenia, during 2007-2012 period is presented in table 1. In this region, the GDP recorded a growth from 33,682.6 million RON, in 2007, to 46,597.9 million RON, in 2012. In which it concerns the county's potential: 31.5% is realized in Dolj county; 23.0% in Gorj county; 18.2% in Valcea county; 17.3 % in Olt county and 9.8% in Mehedinți county

Table 1. Dynamics of Gross Domestic Product in South-West region of Oltenia, during 2007-2012 (millions RON)

Specification	2007	2008	2009	2010	2011	2012	2012/2007 (%)
SOUTH-WEST OLTENIA Region	33,682.6	40,742.1	40,401.5	42,368.6	44,583.5	46,597.9	138.3
Dolj	10,554.2	13,555.8	13,520.2	13,609.3	14,307.3	14,685.8	139.1
Gorj	7,340	8,150.5	8,876.9	9,758.2	10,242.1	10,749.4	146.4
Mehedinti	3,741.2	4,435.5	4,422.7	4,324.1	44,79.6	4,572.7	122.2
Olt	5,452.9	6,669.7	6,113.6	7,166.4	7,262	8,103.9	148.6
Valcea	6,594.3	7,930.6	7,468.1	7,510.6	8,292.5	8,486.1	128.6

Source: [14]; own calculations

In order to highlight the GDP evolution, one required it's analysis by resources categories. The dynamics of Gross Domestic Product by resources categories within the South-West region of Oltenia, during 2007-2012 period is presented in table 2. The Gross Domestic Product has been realized on the basis of activities in different economy's sectors [2]. One could observe an increase of GDP by resources categories, in 2012 in comparison with 2007. This growth is different, ranging between 2.8% and 86.5%. During the analyzed period, the most significant contribution to creating GDP was the one of services' sector, closed followed by industry, constructions and agriculture. According to specialists' opinion, the GDP/capita represents an important indicator which is

being used when one deserve to characterize the developing level of a certain area. It must not be forgotten the fact that there is a close connection between GDP/capita and population's living standard [15]. In accordance with official data given by Eurostat, Romania is on the 27<sup>th</sup> place, regarding the living standard measured through GDP/capita. In Romania, the living standard records, nowadays, a quarter of European Union's living standard at gross level [8]. It must not be forgotten that, in the situation of using GDP/capita at regional level one would identify a breach concerning the economic performance of the area in comparison with other regions [5].



Table 2. Dynamics of Gross Domestic Product by resources categories in South-West region of Oltenia from Romania, during 2007-2012 (millions RON)

Specification	2007	2008	2009	2010	2011	2012	2012/2007 (%)
Agriculture, forestry and fishing	1,873.1	3,471.9	3,240	3,394.1	4,111	3,144	167.8
Mining and quarrying; manufacturing; production and supply of electricity and heat. gas. steam and air conditioning; water distribution; sanitation. waste management. remediation activities	9,229.8	10,331.9	10,432.3	13,498	14,975	14,189.5	153.7
Construction	3,468.6	4,577.5	4,533.8	4,352.2	3,798.7	4,309.4	124.2
Wholesale and retail trade; repair of motor vehicles and motorcycles; transport and storage; hotels and restaurants	5,864.4	7,079.4	6,716.6	5,137.3	4,931.2	7,257.5	123.7
Information and communication	466.4	578.4	526.5	593.3	537	657.9	141.0
Financial and insurance	356	453.4	422	422.4	243.2	529.5	148.7
Real Estate	3,167.4	3,017.7	3,446	3,210	2,979.8	3,256.5	102.8
Professional activities. scientific and technical; activities of administrative services and support service activities	909.8	1,027.6	1,088.7	1,213.1	1,481.7	1,386.6	152.4
Public administration and defense; social security insurance; education; Health and social care	4,020.4	5,200.4	5,425.7	5,360.2	5,179.3	5,274.1	131.1
Entertainment activities. entertainment and recreation; repair of household goods and other services	504.3	589.3	617.5	757.2	886	940.8	186.5
Regional gross value added (RGVA)	29,860.2	36,327.5	36,449.1	37,937.8	39,122.9	40,945.8	137.1
Taxes on products	3,948.4	4,480.1	4,041.9	4,587.2	5,340.5	5,649.6	143.0

Source : [14]; own calculations

The dynamics of GDP/capita within the South-West region of Oltenia from Romania, during 2007-2013 is presented in table no. 3. Analyzing the data from the table, one could observe an increase of the GDP per capita in the South-West region of Oltenia, with 18.8%

in 2013 than in 2007. In 2013, in Gorj county was recorded the highest level of GDP/capita of 7,149 Euro. On the opposite site one could find Mehedinti county where it was recorded the smallest value of GDP/capita, 3,938 Euro.

Table 3. Dynamics of Gross Domestic Product per capita within the South-West region of Oltenia from Romania, during 2007-2013 (Euro/capita)

Specification	2007	2008	2009	2010	2011	2012	2013	2013/2007 (%)
SOUTH-WEST OLTENIA Region	4,524	4,842	4,190	4,264	4,741	4,851	5,376	118.8
Dolj	4,491	5,139	4,468	4,455	4,905	5,160	6,022	134.0
Gorj	5,978	5,757	5,476	5,509	6,204	6,660	7,149	119.5
Mehedinti	3,767	4,042	3,513	3,565	3,809	3,613	3,938	104.5
Olt	3,506	3,836	3,078	3,326	3,783	4,002	4,315	123.0
Valcea	4,957	5,215	4,275	4,349	4,854	4,488	4,843	97.7

Source : [12]; own calculations

Analyzing the GDP/capita, one could observe that the South-West region of Oltenia is on the last but one place through the country's areas. It is very easy to see that GDP/capita is under the national average in this region. In order to reduce disparities in comparison with the other regions in Romania, it is necessary to attract both foreign and national investors. These investments could lead to: creating new jobs; exploitation of natural resources places; exploitation of touristic potential; growth of

regional competitiveness and so on.

In table no. 4 it is presented a prognosis of GDP/capita in South-West region of Oltenia in Romania, for 2015-2017 period of time. Within this area, one could estimate an increase of 13.3%, in 2017 compared to 2015. The highest value of GDP/capita is considered to be recorded in Gorj county (9075 Euro), while the lowest one could be in Mehedinti county (4,958 Euro), in 2017.

Table 4. Assessments on the dynamics of GDP/capita within the South-West region of Oltenia during 2015-2017 (Euro/capita)

Specification	2015	2016	2017	2017/2015 (%)
SOUTH-WEST OLTENIA Region	6,047	6,412	6,854	113.3
Dolj	6,800	7,232	7,750	113.9
Gorj	8,018	8,494	9,075	113.1
Mehedinti	4,404	4,653	4,958	112.5
Olt	4,866	5,167	5,527	113.5
Valcea	5,425	5,728	6,100	112.4

Source: [13]; own calculations

The evolution of regional economy also depends on the number of active companies. The dynamics of active companies within the South-West region of Oltenia in Romania, during 2007-2013 period of time, is being presented in table no.5. One could easily

observe an oscillatory trend from a period to another one concerning the companies in this region. In 2013, in comparison with 2008, it was recorded a decrease of active companies, both at regional and county level.

Table 5. Dynamics of active companies in South-West region of Oltenia in Romania, during 2008-2013 (number of units)

Specification	2008	2009	2010	2011	2012	2013	2013/2008 (%)
SOUTH-WEST OLTENIA Region	39,780	38,967	35,956	33,258	34,849	35,360	88.8
Dolj	14,446	14,116	13,157	12,271	13,091	13,400	92.7
Gorj	6,492	6,445	5,993	5,532	5,710	5,776	88.9
Mehedinti	4,179	4,010	3,639	3,226	3,357	3,278	78.4
Olt	6,555	6,576	6,129	5,725	6,052	6,160	93.9
Valcea	8,108	7,820	7,038	6,504	6,639	6,746	83.2

Source : [14]; own calculations

The distribution of active companies at county level within the South-West region of Oltenia in 2013 is presented as follows: Dolj county (37.8%); Vâlcea county (19%); Olt county (17.4%); Gorj county (16.3%) and Mehedinti county (9.2%). The industrial activity within this area recorded an increase from 2005 to 2007, and during 2008-2009 it recorded a decrease due to the economic and financial crisis [9]. The decrease of active companies'

number shows very clear, a state of economic regress of South-West region of Oltenia [15].

The turnover represents the total incomes realized from the commercial activity of a company, during a period of time. Turnover does not comprise financial and extraordinary incomes. Turnover is an essential element when there is been realized a company evaluation. Modifying the turnover influences the main economic-financial indicators,

marking the company's efficiency degree [16]. In accordance with the speciality literature, net turnover represents an indicator of profit and loss Account, consistent in total incomes realized after trading products and services of the company's current activity, including investments subventions, after deducting trade with discounts. Turnover offers numerous

information about: companies' activities dynamics; company's placement on the market; company's self-financing capacity and so on [4].

Turnover dynamics within active companies by sectors of activity in South-West region of Oltenia, during 2008-2013 is being presented in table 6.

Table 6. Turnover dynamics within active companies by sectors of activity in South-West region of Oltenia, during 2008-2013 (millions RON in current prices)

Specification	2008	2009	2010	2011	2012	2013	2013/2008 (%)
Total	954,790	852,424	900,240	1,001,627	1,057,270	1,049,538	109.9
Industry	320,665	284,312	322,283	366,288	384,966	389,965	121.6
Construction	93,210	79,737	72,874	77,878	77,720	68,879	73.8
Wholesale and retail trade, maintenance and repair of vehicles and motorcycles	48,771	31,401	31,457	34,866	36,928	29,914	61.3
Wholesale trade excepting vehicles and motorcycles	118,183	108,515	114,962	131,244	142,631	144,609	122.3
Wholesale trade excepting vehicles and motorcycles	220,690	203,733	210,409	232,999	244,517	240,560	109.0
Market services for population	14,234	12,669	12,377	13,299	14886	14,693	103.2
Market services to enterprises	139,037	132,057	135,878	145,053	155622	160,918	115.5

Source : [14]; own calculations

In 2013 compared to 2008, turnover at regional level increased with 9.9%. Concerning the turnover realized by active companies in different activity sectors, one could observe a distinct evolution in 2013 than in 2008.

There were registered increases associated with the turnover, as following: the industrial sector (+21.6%); Market services for companies (+15.5%); Wholesale trade excepting vehicles and motorcycles (+9.0%); Market services for population (+3.2%). At the opposite side, there are being registered significant reductions, such as: Wholesale and retail trade, maintenance and repair of vehicles and motorcycles (-38.7%) and constructions (-26.2%).

Investments realized in different sectors of the national economy represent the basis of economic development. Decision of an economic agent regarding investments' realisation is based on compared analysis of a series of economic indicators, as following:

-The ratio between the current income value, which is going to be achieved through

investment and its' cost;

-The ratio between updated net income rate and real interest rate;

There is a series of factors that influence the investments size: investments demand; state policy in investments field; general situation of national economy; investors prognosis about the dynamics of trade and profit and so on [1].

Gross dynamic of investments by activity sectors in the South-West region of Oltenia, during 2008-2013 is presented in table 7.

In table 8 is presented the net investments dynamics in local units by national economy's activities within the South-West region of Oltenia, during 2008-2012.

Net investments had a different evolution, a period to another. In 2011 this area had a percentage of 8.1% of net investments.

In 2013, net investments increased by 70.4% compared to 2008, for "Agriculture, hunting and ancillary services". "Real estate, renting and service activities provided mainly to enterprises" sector declined by -6.7%) in the same analyzed period.

Table 7. Gross dynamic of investments by activity sectors in the South-West region of Oltenia, during 2008-2013 (millions RON)

Specification	2008	2009	2010	2011	2012	2013	2013/2008 (%)
Total	143,102	99,048	91,520	14,2796	119,988	109,376	76.4
Industry	53,182	40,602	41,382	83,777	54,400	51,355	96.5
Construction	24,191	16,943	12,865	17,251	25,778	22,123	91.4
Wholesale and retail trade, maintenance and repair of vehicles and motorcycles	3,486	1,735	1,405	1,113	1,397	1,303	37.3
Wholesale trade excepting vehicles and motorcycles	8,497	5,446	5,929	6,713	5,988	4,995	58.7
Wholesale trade excepting vehicles and motorcycles	11,316	7,116	5,522	5,760	5,577	5,365	47.4
Market services for population	3,872	2,110	2,460	1,968	1,992	1,497	38.6
Market services to enterprises	38,558	25,096	21,957	26,214	24,856	2,2737	58.9

Source : [14]; own calculations

Table 8. Net investments dynamics in local units by national economy's activities within the South-West region of Oltenia, during 2008-2012 (millions RON)

Specification	2008	2009	2010	2011	2012	2012/2008 (%)
Total	5,492	4,736	4,996	6,148	6,086	110.8
Agriculture, hunting and ancillary services	149	144	162	245	254	170.4
Forestry and Logging	13	8	16	15	17	130.7
Fishing and Aquaculture	0	0	2	2	7	-
Industry, construction, trade and other services	5,330	4,584	4,816	5,886	5,808	108.9
Real estate, renting and service activities provided mainly to enterprises	166	105	98	197	155	93.3

Source : [14]; own calculations

In table 9 it is presented the staff dynamics in local units by economy's activities within South-West region of Oltenia, during 2008-2012.

Table 9. Staff dynamics in local units by economy's activities within South-West region of Oltenia, during 2008-2012 (number)

Specification	2008	2009	2010	2011	2012	2012/2008 (%)
Total	358,604	319,654	299,766	309,437	312,422	87.1
Agriculture, hunting and ancillary services	6,171	6,089	6,259	6,045	6,415	103.9
Forestry and Logging	3,664	3,650	3,218	4,001	4,082	111.4
Fishing and Aquaculture	71	59	75	137	89	125.3
Industry, construction, trade and other services	348,698	309,856	290,214	299,254	301,836	86.5
Real estate, renting and service activities provided mainly to enterprises	24,339	25,049	24,146	26,266	27,839	114.3

Source: [14]; own calculations

At regional level, one could observe a decrease of staff in local units, with 12.9% in 2012 in comparison with 2008. At county level, the highest percentage is the one of staff in "Industry, construction, trade and other services" sector, while the lowest one is in "Agriculture, hunting and ancillary services;

Forestry and Logging; Fishing and Aquaculture" sector. As investments will increase within South-West region of Oltenia, number of employees will grow too.

## CONCLUSIONS

According to the analysis of main specific

indicators, one could conclude, as following:

-The GDP realized in South-West region of Oltenia increased in 2012 with 38.3 % in comparison with 2007;

-The GDP per capita that was realized in 2013 had a value of 5376 Euros, compared to 4524 Euros in 2007;

-In 2013, active companies registered a diminution than in 2008;

-The turnover at regional level increased with 9.9% (2013) compared to 2008;

-Gross and net investments oscillated one period to another, particular by the activity sector;

-Staff that took part in developing economic activities within local units was reduced in 2012 in comparison with 2008.

Profile until 2017, November 2013

[14]www.insse.ro, 2015

[15]www.progressocial.ro/bloguri/regiunea-oltenia-opportunitati-perspective-economice-6

[16]www.univstlupascu.ro/resurse/Tematica\_licenta\_2010/Analiza\_economico-financiara.pdf

## REFERENCES

[1]Angelescu, C., Ciucur, D., Dobrotă, N., Gavrilă, I., Ghiță, P.T., Popescu, C., Târhoacă, C., 2000, Economy, The 5th edition, ASE, Economic Publishing House, Bucharest, 2000, 241-243

[2]Anghelache, C., 2014, Economic state on recovery way, Economic Publishing House, 120

[3]Beciu, S., 2013, Sustainable Rural Development: Current Trends and perspectives of the Northeast Region of Romania, Ceres Publishing House, Bucharest, 25

[4]Caruntu, R.C., 2011, Theoretical aspects regarding the turnover analysis, Annals of "Constantin Brâncuși" University in Târgu Jiu, Economy series, Nr. 3/2011177,183([http://www.utgjiu.ro/revista/ec/pdf/2011-03/22\\_ROXANA\\_CORINA\\_CARUNTU.pdf](http://www.utgjiu.ro/revista/ec/pdf/2011-03/22_ROXANA_CORINA_CARUNTU.pdf))

[5]Istudor, N., 2006, Rural and Regional Development of Romania in the perspective of European Union integration, ASE Publishing House, Bucharest, 76

[6]Marin, C., Sima, I., Ruxanda, M., 2012, Sustainable development of South-West Region of Oltenia in conditions of actual economic crisis, Theoretical and applied economy, the 19th Volume, No.1 (566):54-64 (<http://store.ectap.ro/articole/678.pdf>)

[7]Oțiman, P.I., (editor), 2006, Sustainable Rural Development in Romania, Romanian Academy Publishing House, Bucharest, 237-238

[8][cursdguvernare.ro/relatia-dintre-evolutia-economiei-si-nivelul-de-trai-romania-in-context-european.html](http://cursdguvernare.ro/relatia-dintre-evolutia-economiei-si-nivelul-de-trai-romania-in-context-european.html))

[9][www.aidoltenia.ro/wpcontent/uploads/2011/08/carte-studiu.pdf](http://www.aidoltenia.ro/wpcontent/uploads/2011/08/carte-studiu.pdf)

[10][www.bnr.ro/Investitiile-straine-directe-\(ISD\)-in-Romania-3174.aspx](http://www.bnr.ro/Investitiile-straine-directe-(ISD)-in-Romania-3174.aspx)

[11][www.ccivl.ro/~ccivlro/images/documents/Geno/PDR-SV-Oltenia-2014-2020.pdf](http://www.ccivl.ro/~ccivlro/images/documents/Geno/PDR-SV-Oltenia-2014-2020.pdf)

[12]www.cnp.ro/ The projection of main economic and social indicators in Territorial Profile until 2015, June 2012

[13]www.cnp.ro/ National Prognosis Commission-The projection of main economic and social indicators in Territorial



## COMPETITIVENESS OF BULGARIAN VEGETABLE PRODUCTION AFTER THE EU ENLARGEMENT

**Teodora STOEVA**

Agricultural University – Plovdiv, 12, Mendeleev, Plovdiv, 4000, Bulgaria, Phone: Phone: (032) 654200, Fax: (032) 633157, E-mail:teodorastoeva@gmail.com

*Corresponding author:* teodorastoeva@gmail.com

### *Abstract*

*Vegetable crop production has been a traditional sub-sector of Bulgarian agricultural plant production. Bulgarian production of vegetables has faced serious changes after the accession of Bulgaria to the EU. The main aim of this article is to examine the competitiveness of Bulgarian vegetables crop production under the influence of the CAP. The increase of competitiveness of Bulgarian vegetables should be the main goal of Bulgarian agricultural policy.*

*Key words:* CAP, competitiveness, development, vegetable crop production

### INTRODUCTION

Ever since the accession of Bulgaria to the European Union, Bulgarian vegetable production has been facing a number of challenges: strict application of the rules of the Common European market, harmonization of the quality standards for agricultural production, strong competition from other European countries, access to the European Union's markets. The application of the common rules, in line with the Common Agricultural Policy, reveals new opportunities for stimulating the producers of high-quality agricultural production and increases the competitiveness of Bulgarian fruits and vegetables.

After the reforms in the agricultural sector Bulgaria has lost its leading positions in the production and export of vegetables. The negative trend in the status and development of vegetable production started back in 1990s and now it is characterized by a constant reduction of the area planted with vegetables, as well as by a significant decrease in the number of vegetable producers.

Our country has lost its position of a traditional vegetable producer and exporter. According to Koteva (2010) the main reasons for the negative trends are the lack of targeted agricultural policy in the pre-accession period, lack of support and incentives for development of the sub-sector.[1]

### MATERIALS AND METHODS

To achieve the objective pursued, the statistical yearbooks and reference books of the National Statistical Institute (NSI) have been used as well as the agricultural reports of the Ministry of agriculture and food, newsletters of the Agrostistics Directorate to the Ministry of agriculture and food, and own researches. Below are presented the main factors that influence the status and competitiveness of vegetable production. The dynamics of the harvested areas, the average yields and the production of the main vegetable crops in Bulgaria are reviewed and analyzed.

### RESULTS AND DISCUSSIONS

The analysis of competitiveness as a part of the issues in vegetable production sector is directly connected with its sustainable development. Bulgarian vegetable production lags behind and is unable to satisfy the consumption. According to data provided by the National Statistical Institute, for the period 2002-2012 the consumption of vegetables by Bulgarian households has been growing, the most significant being the increase in the consumption of cabbage – by 29% and mushrooms - 75%. Vegetable crops are a major part of the diet of Bulgarians due to their rich content of vitamins and nutrients.[4]

The fresh vegetables that define the structure of Bulgarian import are tomatoes, peppers, cucumbers, potatoes and onions. A negative trend is observed in all these vegetables: the export is significantly lower than the import. Among the main reasons undoubtedly are the competitive prices of these products as well as the fact that Bulgarian vegetable producers cannot satisfy the needs of the market.[2] The deficiency in the domestic production of vegetables is compensated by the import of vegetables – mainly from Turkey which is the main competitor of Bulgaria. Nearly 73% of the fresh vegetable import – tomatoes, peppers, cucumbers, onions, garlic, etc., is carried out by neighbouring Turkey.

Vegetable production is heavily dependent on the natural and climatic conditions in our country and in some cases the varieties used are not resistant to the changes of the natural conditions (drought, high humidity). The natural factors largely determine the regional specificities in the sub-sector. The variety of climatic and soil conditions contributes to the development of vegetable production, given the fact that most of the crops are grown in the plains and lowlands of Bulgaria.

The status and competitiveness of vegetable production is affected by a number of socio-economic factors such as the demographic resources, agricultural equipment for processing vegetable crops, markets for realization, the policy of our country, the condition of transportation and others.

A typical feature of the outdoor vegetable production is the involvement of a lot of manual work and a relatively limited capacity for mechanization of the production processes. In this connection, the most disadvantaged vegetables are those that ripen at different periods since a lot of labor force is required for their harvesting - such vegetables are the early tomatoes, green peppers, cucumbers, eggplants, etc. This characteristic leads to an increase in the production cost while some vegetables suffer a significant drop in profitability - early tomatoes, green peppers and others. This circumstance imposes these crops to be grown in the most suitable soil and climatic conditions, in order to use the natural factors and it requires

proper zoning and territorial specialization of vegetable crops. It is necessary to introduce new technologies which will allow to increase the level of mechanization of work processes - this will sharply reduce the use of manual labour and will lead to increase of labour productivity and reduction of production cost. Thus, the involvement of manual work will be reduced significantly - mechanized labour will substitute it by means of assimilating new, more perfect, means of production. This can be realized in the following areas:

- Increase of the relative share of vegetables for which there are technological solutions for limited input of manual labour and of vegetables that are mainly used for raw material in the canning industry;

- Implementation of industrial technologies; The implementation of industrial technologies for outdoor production of vegetables requires qualitative changes not only in the varieties used but also in the agricultural equipment, irrigation methods, methods of crop harvesting, mechanization of the different work processes. The requirements for the selection of new vegetable varieties to meet the criteria for the utilization of industrial production methods are as follows:

- A high degree of stability in the average yields;

- Resistance to diseases and pests;

- High quality of production;

- Optimal utilization of the intensive factors in vegetable production – agricultural equipment, irrigation, pest and disease control, mechanized harvesting of production etc.

In this connection, it is essential to determine the correct guidelines for research in the selection of vegetable crops such as expansion of the genetic resources of vegetable species and improvement of the methods of hybridization. This will lead to the creation of new varieties for industrial production with good suitability.

For the period 2007 – 2013, the harvested areas of the studied vegetable crops tend to change - the areas plated with tomatoes, potatoes and green pepper are decreasing while there is an insignificant increase of the areas planted with the rest of the vegetable crops.



Table 1. Size and dynamics of harvested areas (dca) planted with some vegetable crops in all categories of farms in Bulgaria, for the period 2007-2013

Crop	2007	2008	2009	2010	2011	2012	2013
Tomatoes	48,280	34,740	30,070	29,240	38,600	34,010	32,420
Cucumbers	4,960	1,250	3,690	7,490	5,500	5,660	5,920
Pepper	54,970	37,505	50,130	47,035	46,205	30,130	40,350
Onions	12,620	12,813	11,792	16,664	14,988	12,790	12,250
Cabbage	22,460	20,928	15,958	26,157	25,542	20,840	19,030
Potatoes	224,270	217,108	140,016	138,050	162,187	149,060	127,650
Water-melons	33,830	35,071	38,590	33,022	37,935	30,910	30,620
Melons	11,890	12,423	17,343	9,909	15,044	12,670	11,190

Source: Ministry of agriculture and food, Agrostatics Directorate

Table 2. Differences of harvested surfaces cultivated with some vegetable crops, 2007-2013, 2007=100, (%)

Crop	2007	2008	2009	2010	2011	2012	2013
Tomatoes	100	-28.1	-37.8	-39.5	-20.1	-29.6	-32.9
Cucumbers	100	-74.8	-25.7	51	10.0	14.1	19.3
Pepper	100	-31.8	-8.9	-14.5	-16.0	-45.2	-26.6
Onions	100	1.5	-6.6	32	18.7	1.3	-2.9
Cabbage	100	-6.8	-28.9	16	13.7	-7.2	-15.3
Potatoes	100	-3.2	-37.6	-38.5	-27.7	-33.5	-43.1
Water-melons	100	3.6	14	-2.4	12.0	-8.6	-9.5
Melons	100	4.5	45.8	-16.7	26.5	6.6	-5.9

Source: Ministry of agriculture and food, Agrostatics Directorate

The dynamics and level of average yields are a factor that has a major influence on the status, development and competitiveness of Bulgarian vegetables. When analyzing the levels of the average yields, it is notable that

they are too low for the vegetables mentioned above. The specific weather conditions have a direct impact on the average yields, but it can be strongly argued that these yields do not meet the potential of the varieties.

Table 3. The average yields (kg/dca) of the main vegetable crops in all categories of farms in Bulgaria for the period 2007 – 2012

Crop	2007	2008	2009	2010	2011	2012	2013
Tomatoes	1,970.9	2,834.5	2,418.2	2,854.5	1,757.6	2,166.6	2,391.8
Cucumbers	1,148.8	1,528.1	1,433.5	2,520.9	2,073.4	1,000.2	1,809.5
Pepper	1,439.5	1,512.4	1,364.8	1,401.4	1,371.7	1,524.2	1,472.5
Onions	839.6	1,248.5	697.3	1,148.9	1,117.5	809.1	1,044.4
Cabbage	2,205.5	3,095.7	2,463.6	3,012.4	1,746.4	2,267.4	2,375.5
Potatoes	1,331.7	1,625.8	1,653.9	1,819.3	1,432.0	1,015.0	1,569.1
Water-melons	2,273.5	2,271.9	2,302	1,876.3	1,792.6	1,802.0	2,101.2
Melons	1,564.8	1,095.5	1,249.6	889.3	1,007.4	1,393.4	1,307.7

Source: Ministry of agriculture and food, Agrostatics Directorate

Table 4. Differences of average yields of the main vegetable crops, 2007-2013, 2007=100, (%)

Crop	2007	2008	2009	2010	2011	2012	2013
Tomatoes	100	43.8	22.7	44.8	-10.8	9.9	21.3
Cucumbers	100	33	24.8	119.4	80.5	-12.9	57.5
Pepper	100	5.1	-5.2	-2.6	-4.7	5.9	2.3
Onions	100	48.7	-16.9	36.8	33.1	-3.6	24.4
Cabbage	100	40.4	11.7	36.6	-20.8	2.8	7.7
Potatoes	100	22.1	24.2	36.6	7.5	-23.8	17.8
Water-melons	100	-0.1	1.3	-17.5	-21.2	-20.7	-7.6
Melons	100	-30.0	-20.1	-43.2	-35.6	-11.0	-16.4

Source: Ministry of agriculture and food, Agrostatics Directorate

One of the most significant issues and a major factor for the low average yields is the application of old-fashioned, more extensive technologies. Another significant reason is the deteriorated hydro-ameliorative system in Bulgaria which makes vegetable production highly dependable on weather conditions.

Taking into account Bulgaria's good opportunities and traditions in the sphere of vegetable production, the average yields of the main vegetable crops are relatively low, but they somehow manage to keep their cost

at a lower level than the prices at which the production is realized.

The analysis of the total vegetable production for the period 2001 – 2013, as well as the production of the main vegetable crops, illustrates that the total production of vegetables follows the unfavorable trend of permanent decrease in production output. There is a clear lasting trend of decline in production, average yields and the areas planted with the major crops.

Table 3. Production of main vegetable crops for Bulgaria, in total and in crops (in thousand tons)

Year	Total vegetables	Tomatoes	Pepper	Cucumbers	Potatoes	Onions	Cabbage
2001	1,567.4	272.6	141.3	62.5	600.4	36.0	138.5
2002	1,583.5	221.4	164.6	73.5	627.3	38.0	109.4
2003	1,834.5	398.0	208.6	56.1	450.1	42.2	138.0
2004	1,590.0	238.0	125.9	87.0	573.0	45.0	117.0
2005	872.6	126.4	72.1	44.7	375.5	14.3	69.3
2006	1,182.9	212.9	156.7	61.5	386.0	20.2	72.6
2007	803.5	133.2	81.7	57.2	298.7	10.6	50.0
2008	874.3	134.1	59.5	62.6	353.6	16.1	64.9
2009	734.9	104.2	71.5	78.0	231.7	8.22	39.4
2010	356.5	114.6	69.1	65.7	251.2	19.1	78.9
2011	368.0	103.1	66.3	58.6	232.3	16.6	44.6
2012	275.8	94.0	47.1	33.7	151.3	10.3	47.3
2013	260, 2	77.7	59.3	11, 1	197.8	13.4	44.9

Source: Ministry of agriculture and food, Agrostatistics Directorate

For the period 2001-2013 the status of vegetable production was constantly deteriorating thus showing the deep crisis in this traditional sector of Bulgarian agriculture. The production of vegetables is far below the level of the years preceding 2007 when it created a value of about and over BGN 1 billion. The high technological costs and the lack of skilled labour also contribute to the worsening of the indicators characterizing the production of vegetable crops in Bulgaria.

## CONCLUSIONS

The reasons for the low level of competitiveness of the vegetable production observed after the accession of Bulgaria to the EU in 2007 are rooted in the failure of the land reform. As a result of this reform, small-sized farms which are ineffective due to the low degree of specialization, insufficient availability of agricultural equipment and

modest level of production organization, dominate the structure of specialized vegetable outdoor farms.[2]

The strong competition of vegetable production from other European countries after the accession of Bulgaria to the Common European market in 2007 and the imports of fresh vegetables have pressed further Bulgarian vegetable production.

The increase of competitiveness of Bulgarian vegetables should be the main goal of Bulgarian agricultural policy.

## REFERENCES

- [1]Koteva, N., 2010, The vegetable production in Bulgaria – status and problems, “Economy and management of agriculture“, Vol.1, p. 14
- [2]National strategy for sustainable development of agriculture in Bulgaria for the period 2014-2020, Ministry of agriculture and food.
- [3]Nikolov, D., Yovchevska, P., Chopeva, M., Koteva, N., Mladenova, M., Kirovski, P., 2014, Institute of agricultural economics, city of Sofia, Analysis of

sectors and coupled support, p. 15-16;

[4]Terziyska, K., 2011, Competitiveness of Bulgarian vegetables on the international market



## **PREREQUISITES AND CONDITIONS FOR THE DEVELOPMENT OF BULGARIAN AGRICULTURE AND VEGETABLE PRODUCTION – CURRENT SITUATION, ISSUES AND PRIORITIES IN THE CONTEXT OF THE CAP**

**Teodora STOEVA**

Agricultural University – Plovdiv, 12, Mendeleev, Plovdiv, 4000, Bulgaria, Phone: (032) 654200, Fax: (032) 633157, E-mail:teodorastoeva@gmail.com

*Corresponding author:* teodorastoeva@gmail.com

### **Abstract**

*Bulgaria has many years of experience, well-established traditions and vast opportunities in the sphere of agriculture and particularly in vegetable production. Vegetable production has been a traditional sub-sector of Bulgarian plant production. The development of this sub-sector is determined by the favorable natural, soil, climatic and geographical conditions in the country as well as by the rich production experience and national traditions of Bulgarian people over the years. Vegetable production forms 15% of the gross output of Bulgarian agriculture, which determines its importance for the agricultural sector in Bulgaria. The evaluation and analysis of the contemporary situation for the development of vegetable production are issues of current importance for Bulgarian agriculture in the context of the Common agricultural policy. The purpose of this article is to examine the prerequisites, conditions, status and issues associated with the development of agriculture and vegetable production in Bulgaria with a view to improving the economic performance.*

**Key words:** agriculture, current situation, development, issues, vegetable production

### **INTRODUCTION**

Vegetable production has been a traditional sub-sector of plant production in Bulgaria. The presence of favourable natural and climatic conditions, the longstanding traditions, wealth of experience, the development of new technological solutions, the use of modern varieties with high biological potential outline the prerequisites and conditions for the development of Bulgarian vegetable farms. The good prerequisites for the development of vegetable production in Bulgaria determine the diversity of vegetables grown.

The membership of Bulgaria in the EU has made the CAP a key factor for the development of Bulgarian agriculture and more particularly, of vegetable production.[5] The purpose of this article is to present the prerequisites as well as modern condition and opportunities for the development of vegetable production in Bulgaria in the context of the Common agricultural policy.

### **MATERIALS AND METHODS**

To achieve the objective pursued, the statistical yearbooks and reference books of the National Statistical Institute (NSI) have been used as well as the agricultural reports of the Ministry of agriculture and food, newsletters of the Agrostatistics Directorate to the Ministry of agriculture and food, and own researches.

The accession of Bulgaria to the Common European market has revealed a number of prerequisites and opportunities for development in the agricultural sector. According to Bencheva [Bencheva,2012] Bulgarian farmers have access to the Single market of the European Union and therefore they benefit from its relatively stable prices and direct payments.[1]

In the conditions of the financial crisis, Bulgarian agriculture faces a difficult choice – farmers have to make serious investments in order to be able to meet the European requirements and standards related to food quality and environmental protection.

The application of the Common agricultural

policy puts the competitiveness of Bulgarian agricultural production to a serious test - now it has to compete with the European production, which is relatively cheaper and more attractive in appearance. The import of fruits and vegetables affects the structure and volume of Bulgarian agricultural production. Therefore, Bulgarian agricultural policy should have clear priorities for the development of the sector and its transformation into a competitive and highly effective branch of Bulgarian economy.

Although in recent years the positive effect for the industry has found expression in significant support with European funding and increasing amount of national funds, in general, the agricultural production in

Bulgaria is characterized by comparatively low competitiveness and insufficient market orientation caused to a great extent by the problems in the sector accumulated during the years of transition. Vegetable production is heavily dependent on the natural and climatic conditions in our country and in some cases the varieties used are not resistant to the changes of the natural conditions (drought, high humidity). Undoubtedly, the variety of climatic and soil conditions are good prerequisites for the development of vegetable production, having in mind that most crops are grown in the plains and lowlands of Bulgaria.

Table 1. Production of main vegetable crops in Bulgaria, in total and in crops, 2001-2013, (thousand tons)

Year	Total vegetables	Tomatoes	Pepper	Cucumbers	Potatoes	Onions	Cabbage
2001	1567.4	272.6	141.3	62.5	600.4	36.0	138.5
2002	1583.5	221.4	164.6	73.5	627.3	38.0	109.4
2003	1834.5	398.0	208.6	56.1	450.1	42.2	138.0
2004	1590.0	238.0	125.9	87.0	573.0	45.0	117.0
2005	872.6	126.4	72.1	44.7	375.5	14.3	69.3
2006	1182.9	212.9	156.7	61.5	386.0	20.2	72.6
2007	803.5	133.2	81.7	57.2	298.7	10.6	50.0
2008	874.3	134.1	59.5	62.6	353.6	16.1	64.9
2009	734.9	104.2	71.5	78.0	231.7	8.22	39.4
2010	356.5	114.6	69.1	65.7	251.2	19.1	78.9
2011	368.0	103.1	66.3	58.6	232.3	16.6	44.6
2012	275.8	94.0	47.1	33.7	151.3	10.3	47.3
2013	260, 2	77.7	59.3	11, 1	197.8	13.4	44.9

Source: Ministry of agriculture and food, Agrostatistics Directorate 2001-2012

The analysis of the total vegetable production for the period 2001 – 2013, as well as the production of the main vegetable crops, shows that the total production of vegetables follows the unfavorable trend of decrease in production output. (Table1). The drastic reduction in production is due to a number of factors. The drop in production volumes can be explained not only with the reduced planted areas, but also with the strong competition in the sector.

## RESULTS AND DISCUSSIONS

Vegetable production also faces a number of issues such as lack of good production organization which is presently characterized

by low technological level, large production costs, including high prices of seeds, fertilizers, plant protection products, irrigation water, lack of mechanization and use of human labor in harvesting. The low degree of organization among producers, lack of commercial arrangements between producers and traders regarding the realization of production, low purchase prices of the finished products, lack of manpower in production and use of low-skilled workers - all these are among the pressing issues of the sub-sector awaiting to be solved for years.[4] These are therefore the main reasons why the problems, status and development of the sub-sector have become a subject of scientific interest. In their studies, a number of authors

reveal the reasons for the negative trend of development and they also outline some opportunities for its overcoming. According to Bogoev and Paskalev [Bogoev; Paskalev,2003] the present production and marketing system of vegetable products is highly fragmented and leads to chaotic marketing and price structure.[2]

According to Masheva [Masheva,2012] the development of vegetable production requires the creation of such production structures that will comply with both the national characteristics and traditions of Bulgarian people and with the European requirements and standards for food quality and safety, which will enable Bulgarian producers to take their worthy place on the European market.[3] The main trends in the selection of vegetable crops that to a great extent are good preconditions for increasing the competitiveness of field vegetable production can be summarized as follows:

-Breeding of varieties which have high overall resistance to diseases and pests, with opportunities for application of mechanized cultivation and harvesting of production, with excellent technology and taste;

-Creating varieties with a high biological value and valuable technological qualities;

All vegetable crops to be grown on irrigated areas with a lot of agricultural activities and the water to be unconditional cost for the production of vegetables. In order to take the utmost advantage of the natural resources – solar energy, soils, rainfall, as well as to increase the efficiency of land use, the following is necessary:

-Preservation of soil fertility by means of introducing an appropriate structure and crop

rotation, correct content of irrigation regulations in accordance with the biological peculiarities of the crops;

-The areas planted with vegetables should be designed so that they are in accordance with the irrigation method, irrigation equipment and other agricultural machinery in order to ensure high labour productivity;

The ways and methods for irrigation of vegetable crops are closely connected with the technical level of irrigation systems and implementation of industrial technologies.

The human factor is an essential resource for the production of vegetables. More than 50% of the people employed in the production and cultivation of vegetables are over the age of 55. The workforce which is a basic prerequisite for the development of the sub-sector is low-qualified and insufficient in number. The low profitability of those employed in vegetable production is another reason for the weak employment in this sub-sector. The technical security of vegetable producers is an important prerequisite and condition for the sustainable development of the activity. It contributes to the increase of labour productivity, improvement of product quality and decrease of costs and losses. An aggravated age structure and insufficient degree of technical security is observed in the majority of vegetable producers.

As a whole, there is a significant decrease in the number of people working in agriculture. In 2010 they were 738 thousands and their number is decreasing by 21 % in comparison with 2007. 88% of them are small family farms. The decrease in the number of family farms is associated mainly with the demographic problems in rural areas.

Table 2. Workforce - total for Bulgaria and for Plovdiv region

Workforce	Bulgaria			Plovdiv Region		
	Workforce total	Family workforce	Non-family workforce	Workforce total	Family workforce	Non-family workforce
Number of people working in farms	738,634	681,466	57,168	65,835	60,856	4,979
Labour invested in Annual Work Units (AWU)	389,107	336,766	52,341	34,102	29,587	4,515

Source: Ministry of agriculture and food, Agrostatics Directorate

Manual labor is indispensable in outdoor vegetable production, with a high degree of mechanization of the work processes – manual earthing, gravity irrigation, cleaning, sorting and loading of production and others. The high labour intensity and the lower degree of mechanization in most vegetable crops are among the reasons why low-qualified seasonal workforce, not interested in the final economic results, is used during the tensest periods.

Bulgarian vegetable production has been experiencing considerable difficulties in adapting to the new market situation ever since 2007 and it finds it difficult to develop its economic and industrial potential.

## CONCLUSIONS

The presence of a great number of small-scale producers, the lack of production planning, insufficiently effective marketing and distribution of agricultural production, weak professional organizations - all these are prerequisites that create difficulties for the development of vegetable production. By establishing associations and organizations vegetable producers would have much greater opportunities for market research as well as for better realization of their production.[4]

The reduced market consumption in Bulgaria, low-qualified and aging workforce and the growing share of informal sector are among the major issues of vegetable production that impose the need to perform a research, analysis and evaluation of its condition as a whole and its degree of readiness for implementing the Common agricultural policy as well as the need of agricultural policy for sustainable development of this traditional Bulgarian sub-sector.

## REFERENCES

- [1]Bencheva, N., 2012, Status, issues and development of agricultural sector of Bulgaria within the framework of the Common agricultural policy, mag. Agricultural sciences, No.9, city of Plovdiv  
[2]Bogoev, G., Paskalev, P., 2003, Organizational and economic problems of outdoor vegetable production, Fifth National Conference of the Union of Bulgarian agricultural economists, City of Sofia

[3]Masheva, S.,2012, Perspectives for the development of vegetable production, 2012 bulletin of the Agricultural Academy

[4]National strategy for sustainable development of agriculture in Bulgaria for the period 2014-2020, Ministry of agriculture and food.

[5]Nikolov, D., Yovchevska, P., Chojeva, M., Koteva, N., Mladenova, M., Kirovski, P., 2014, Analysis of sectors and coupled support, Institute of agricultural economics, city of Sofia, p.15



## AT THE BEGINNING OF A NEW REGIONAL STRATEGY BASED MOSTLY ON GROWTH. 2020 EUROPE STRATEGY- TARGET ON POVERTY

Roxana STOIAN

Bucharest University of Economic Studies, Faculty of Agrifood and Environmental Economics, 5-7, Mihail Moxa Street, Bucharest, Romania, Email: roxanaistoian@gmail.com

*Corresponding author:* roxanaistoian@gmail.com

### Abstract

*In the attempt to understand how does the European Union want to develop in the following decade, it is important to find that all its plans took the shape of a new strategy, called The 2020 Europe Strategy. This paper aims to analyze the fifth target of the strategy, poverty and social exclusion and to see how does it is applied for Romania and how can the country diminish this indicator, leaving the last but not one place of the statistics regarding poverty, followed only by Bulgaria. In this respect, it is made a short analysis of the most important social indicators over the population at poverty or social exclusion, at risk of financial poverty, severe material deprivation or from very low work intensity households. The main conclusions were that Romania will continue to have a poor population as it is stated by the European indicators at more than 50% with less and less chances to target the 20% of the population in risk of poverty and social exclusion by the end of 2020.*

**Key words:** goals, objectives, poverty, strategy, targets

### INTRODUCTION

Europe 2020 is the European Union's ten-year growth and jobs strategy that was launched in 2010. It is about more than just overcoming the crisis from which our economies are now gradually recovering. It is also about addressing the shortcomings of our growth model and creating the conditions for a smart, sustainable and inclusive growth[2].

Five headline targets have been set for the EU to achieve by the end of 2020. These cover employment; research and development; climate/energy; education; social inclusion and poverty reduction. These are the following:

**Employment**-75% of the 20-64 year-olds to be employed;

**R&D**-3% of the EU's GDP to be invested in R&D;

**Climate change and energy sustainability:** greenhouse gas emissions 20% (or even 30%, if the conditions are right)lower than 1990; 20% of energy from renewables; 20% increase in energy efficiency;

**Education**- Reducing the rates of early school leaving below 10%; at least 40% of 30-34-year-olds completing third level education;

**Fighting poverty and social exclusion**- at least 20 million fewer people in or at risk of poverty and social exclusion.

All these established targets have the main purpose to see how it will look the European Union in 2020. They are also translated into country targets, in order to be easier to understand and check the progress of each country. What is the most important fact, is that they are obeying the European functioning principle, meaning that are common goals for all members and also involve interrelated and mutual reinforcement because the education helps the labour market, results of R&D investments raises the competitiveness and create jobs and the greener environment keeps clean the planet and creates new opportunities of green businesses or jobs.

Together with targets, the new strategy brings also new objectives based on smart, sustainable and inclusive growth, such as:

-Digital agenda for Europe;

-Innovation Union;

-Youth on the move;

-Resource efficient in Europe;

-An industrial policy for the globalization area;

-An agenda for new skills and jobs;  
-European platform against poverty.

Europe 2020 does not forget about its main priorities as innovation, the digital economy, employment, youth, industrial policy, poverty, and resource efficiency and continues to use the European single market, the EU budget and the EU external agenda to achieve the goals from above.

Fighting poverty and social exclusion is one of the targets where Romania has one of the most highest percentage of people at risk of poverty and social exclusion according to the State of play and progress at national level [4], being followed only by Bulgaria.

Managing to low the poverty and social exclusion is one of the strategy' targets placed before any other industrial investment or economic growth because it is considered to be smart, durable and inclusive growth of the next decade.

## **MATERIALS AND METHODS**

The materials used in this paperwork include European legislation, European statistical information from headline indicators of the 2020 Strategy, Romanian databases from INSSE in order to compare the information, and also the European timeline, The European Semester regarding the moments and duties of the institutions responsible for the implementation of the Strategy. Least, but not last, the research will involve a short analysis of the two European important instruments, Annual Growth Survey (AGR) and Alert Mechanism Report (AMR).

The methods applied will be empirical analysis and comparison, critical remarks and personal opinions about the changes of Romania to point the targets established by the strategy.

## **RESULTS AND DISCUSSIONS**

The target set by the EU corresponds to a situation where 96.4 million people are at risk of poverty or social exclusion in 2020. When referring to the number of people at risk of poverty or social exclusion, the indicator includes the number of people affected by at

least one of the three types of poverty, namely income poverty (people at risk of poverty after social transfers), material poverty (severely materially deprived people) and people living in households with very low work intensity[1].

The years until 2009 were marked by a steady decrease in the number of people exposed to poverty or social exclusion. The lowest level was reached in 2009, with around 114 million people at risk of poverty or social exclusion, against more than 124 million in 2005. However, the crisis offset these positive developments and led to a rise in the values of the EU-28 aggregates, with the number of people at risk of poverty or social exclusion increasing to more than 118 million in 2010, more than 121 million in 2011 and more than 124 million in 2012. Monetary poverty affects the highest number of people and severe material deprivation has increased most rapidly, by 7.1 million people since 2010.

Based on recent trends and according to the latest projections, the EU target of reducing the number of people at risk of poverty or social exclusion to 96.4 million by 2020 is unlikely to be met and the indicator might remain close to 100 million[5].

Compared to the European target of lifting 20 million people out of poverty and social exclusion, the aggregated national targets are less ambitious and correspond to reducing the number of people at risk of poverty or social exclusion by around 12 million. As a result of the crisis, vulnerability to poverty and social exclusion has increased in most Member States. Therefore, in 2012, only two countries, Germany and Latvia had met their targets. Poland is very close to achieving its target while Bulgaria, Lithuania, Czech Republic and Finland are moving in the right direction. Italy, Hungary, Greece and Spain are furthest from their respective targets[6].

The crisis has not affected all Member States to the same extent nor with the same intensity and has exacerbated the differences between Member States. In 2008, the distance between the two extremes, namely the Netherlands with 14.9 % of the population at risk of poverty or social exclusion and Bulgaria with

44.8%, amounted to almost 30 percentage points.

People at risk of poverty or social exclusion and its sub-indicators, 2005-2020\*

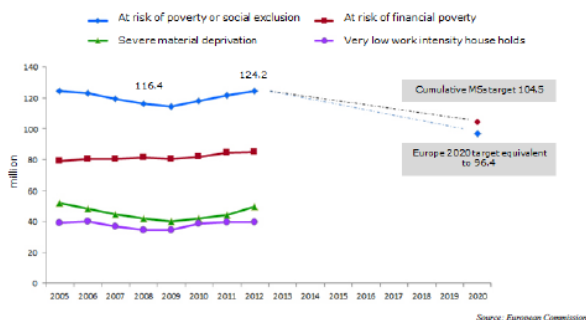

Fig.1. People at risk of poverty or social exclusion and its sub-indicators, 2005-2020  
Source: European Commission

This gap rose to 34.3 percentage points in 2012, from 15% in the Netherlands to 49.3% in Bulgaria. [3].

People at risk of poverty or social exclusion in EU Member States\* (% of population)

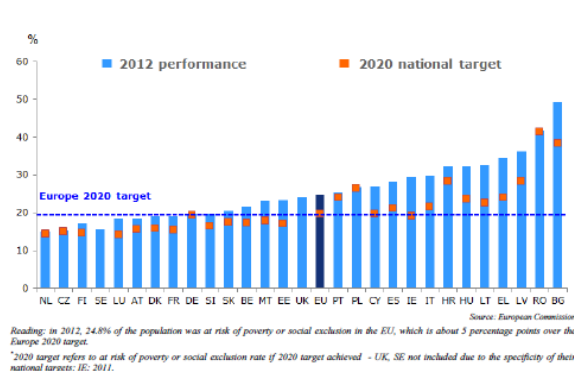

Fig.2. People at risk of poverty or social exclusion in the EU member states  
Source: European Commission

Regarding Romania, Fig.2 shows that the percentage of population in poverty risk is at 40% in 2012 and the national target for this indicator is established at the approximately same value, placing the country on the before last position, only in front of Bulgaria. This fact is serious proof of the low living level of the population and the existence of wealth disparities in the country.

Romania's poverty level evolution had a linear evolution from 2008 to 2012, its significant increase being registered in 2009 due to an economic raise.

Fig.3. emphasized after 2009 a slight evolution, but keeping the same trend.

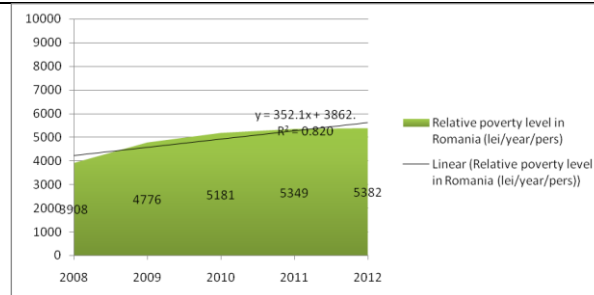

Fig.3. Relative poverty level in Romania, 2008-2012  
Source: data processing over Living level- Relative poverty level, INSSE- TEMPO online

Deepening our analysis, the national statistics show, as emphasized in the Fig.4., that the relative poverty rate had a same overall trend both on main developed regions as in total, registered the usual economic and not new gaps between Bucharest-Ilfov region, but county in reality, and East or West regions.

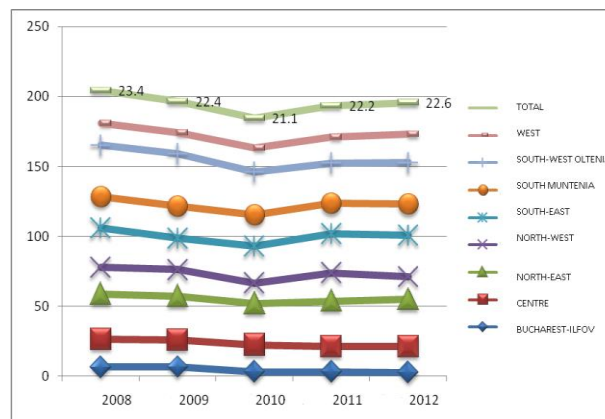

Fig.4. Relative poverty in Romania by macro-region, 2008-2012  
Source: data processing over Living level- Poverty relative rate on regions, INSSE- TEMPO online

If it were to measure the poverty relative rate on regions, it is clear that major discrepancies are undoubtedly high, and all eight regions follow the same trend.

Analysing the same poverty indicator from another economic perspective, emphasizes that in 2012, more than 6% of people had more than 5 economic problems, approximately 20% had no problems and the difference of more than 70% had between 1 and 5 economic problems which highlights the urge of this social situation.

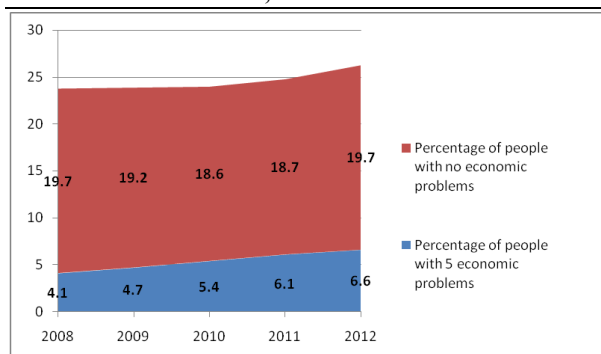

Fig.5. Percentage of people with economic problems compared to people without economic problems

Source: data processing over Living level- Poverty relative rate on regions, INSSE- TEMPO online

[4]Nikolka Till, 2013, Risk of poverty and social exclusion in the European Union, DICE Report, winter 2013, pp. 48-49;

[5]Oxford Analytica Daily Brief Service, European Union: EU poverty levels are bound to rise, Oxford Analytica Ltd, Aug 08, 2012

[6]Piachaud David, 2000, Comment & Analysis: Analysis: Poor relations: In the next two waves of European Union enlargement, the relative poverty of central and eastern Europe will bring drastic changes, The Guardian, Dec 1, 2000

## CONCLUSIONS

Having an overview on the poverty and social exclusion indicators, even stated on an European strategy helps designing the actual living level and its perspectives.

Regarding Romania in this indicators, national targets are even lower than Bulgaria and the population with serious economic problems is increasing year by year.

To fight against this problem, the Government should take correct decisions not only on social measures, but also on education, but this is the subject of a future research.

## ACKNOWLEDGMENTS

This research work was co-financed from the European Social Fund through Sectoral Operational Programme Human Resources Development 2007-2013, project number POSDRU/159/1.5/S/142115 „Performance and excellence in doctoral and postdoctoral research in Romanian economics science domain”.

## REFERENCES

[1]Communication from the Commission, Taking stock of the Europe 2020 strategy for smart, sustainable and inclusive growth [http://ec.europa.eu/europe2020/pdf/europe2020stocktaking\\_annex\\_en.pdf](http://ec.europa.eu/europe2020/pdf/europe2020stocktaking_annex_en.pdf), pp.23

[2]Europe 2020 in a nutshell, European Commission website, [http://ec.europa.eu/europe2020/europe-2020-in-a-nutshell/index\\_en.htm](http://ec.europa.eu/europe2020/europe-2020-in-a-nutshell/index_en.htm)

[3]Jezek Filip, 2014, Measuring Welfare and Poverty in the European Countries, Journal of Eastern Europe Research in Business & Economics, pp. 1-9.

## TRENDS TO PROMOTE EXPORT OF LOCAL AGRICULTURAL AND FOOD PRODUCTS UNDER THE CONDITIONS OF EUROPEAN ECONOMIC INTEGRATION

Elena TIMOFTI<sup>1</sup>, Ghenadie TIMOFTI<sup>2</sup>

<sup>1</sup>State Agrarian University of Moldova, 44, Mircesti St., MD – 2049, Chisinau, Republic of Moldova, Phone: +373 767 15 222, Fax: (+373 22)31-22-76, Email:e.timofti@uasm.md

<sup>2</sup>European Institute of Scientific Research “IMPACT”, 6A, Vasile Harea Street, Chisinau, Republic of Moldova, Phone: +373.680.841.27, Email: ghtimofti@mail.ru

Corresponding author: ghtimofti@mail.ru

### Abstract

*This paper deals with the trend to promote export of local agricultural and food products from the Republic of Moldova. We have analyzed the dynamics and structure of the trade balance, the development and the trend to change exports and imports of the Republic of Moldova depending on the partner countries as well as the evolution of exports by the type of agricultural and food products in 2009 - 2013. Research by the authors is based on statistical analysis methods of time series and the application of statistical methods for estimating trends in exports and imports of food products in Moldova. Thus, the authors concluded that reorientation is required to producers of agricultural products to other markets than the traditional, while improving product quality and review marketing strategies, targeting in particular the Russian Federation.*

**Key words:** economic integration, export, import, promotion, quality, trends

### INTRODUCTION

The economy of each country depends on the connection with the external world by the mechanism of external trade changes with goods and services. The capacity of a state to ensure its “economic sovereignty” can be appreciated through development angle of external trade with goods and services. The impact of exports and imports on domestic prices, exchange rates, interest rates, including on macroeconomic balance on a whole is crucial for economic growth and sustainable development [7].

Based on the decisive role that agriculture plays in economic and social aspect for any state, addressing issues that prevent its development presents an interest of great topic and importance. Currently, agriculture and food industry in the Republic of Moldova are the most important sectors, designed to contribute greatly to the economic growth of the country. About 24.3% of working population is employed in agricultural sector and the share of agriculture to gross domestic product in 2013 was of 12.3% [6]. It is

obvious that the agro-food sector of the Republic of Moldova needs to promote in future export. Only sustainable development of the country shall give the opportunity to develop these industries and to increase export potential of the Republic of Moldova.

External trade is important for the Republic of Moldova. Being part of a complex system of socio-economic and political relations, external trade is sensitive to changes of certain wide range of factors with direct or indirect impact [3].

Relatively tighten local market, domestic stocks of raw materials and energy resources insufficient to cover the country's needs - both for intermediate consumption (production of goods and services), and for final consumption (households, public and private administration consumption), determines a high level of dependence on imports of the Republic of Moldova, fact that makes it vulnerable to market shocks of financial goods.

The structure of external trade is an important factor capable directly and indirectly to influence in general not only on the level of

economic development, but also on the life quality of country's citizens [4]. In 2013 export was focused on markets of the Russian Federation (in measure of about 47%) and EU countries - 38%.

Currently, the Republic of Moldova needs a well-balanced policy focused on overcoming the financial crisis, ensuring the competitiveness of Moldovan products in accordance with the trends and requirements manifested on global markets.

## MATERIALS AND METHODS

In the research, the authors used materials of the National Bureau of Statistics of the Republic of Moldova, reports of Chamber of Commerce and Industry of the Republic of Moldova. In the process of scientific research were applied the following research methods: comparison method, table method and graphical presentation of the studied phenomena, medium size, relative method, the leveling process of chronological series based on linear equation of first degree.

## RESULTS AND DISCUSSIONS

Evolution of the value of imports suggests the fact that the Republic of Moldova was and also is an active importer on the background of acute state of deficit of local products satisfying the demand for similar products of import. Low added value of exports of the Republic of Moldova constitutes an element of low competitive and insufficient tech of production processes, especially of those associated with traditional export industries: food industry, alcoholic beverages, soft drinks, tobacco, etc.

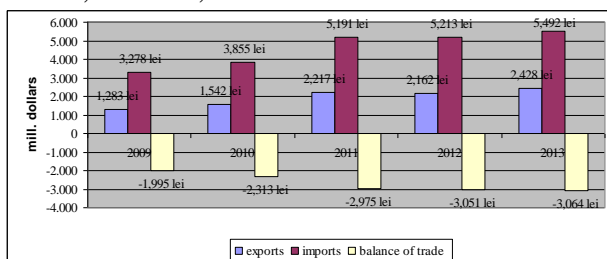

Fig. 1. The evolution of external trade of the Republic of Moldova during 2009-2013, mill. dollars.

Source: processed by the authors based on data of the National Bureau of Statistics.

The analysis of external trade of the Republic of Moldova during 2005 - 2013 (Fig. 1) shows an increased trend with higher rates of imports with a negative balance of trade balance.

The trade deficit is a primary problem of macroeconomic policies of the Republic of Moldova. In this regard, an argument is the fact demonstrated by international practice, that a country with a negative balance of trade balance, which is maintained for a long time, presents the risk of losses of its economic sovereignty.

The trade balance deficit increased from 1202, USD 3 million in 2005 to USD 3,307.7 million in 2008 and since 2009 the balance deficit essentially decreased and reached 1995 million dollars. Starting with 2010 essentially was increased imports that have caused increasing trade deficit to USD 3,064 million in 2013. A positive balance is satisfied only on name of exports of fruits, cereals, alcoholic and soft drinks, fats and vegetable oils.

It shall be mentioned that in recent years was increased the share of exports of wheat grains, sunflower oil, honey to Italy. In some countries like Switzerland, Bulgaria, Spain, Austria, Germany, Israel, Hong Kong, Mongolia shall be exported nuts, honey, dried fruit, jams, marmalades. Also, there has been a decrease of export of products to Poland, Hungary, and Czech Republic.

This fact indicates that it can be penetrated new sale markets but for this is needed appropriate quality products and intense promotion. For instance, the company "Orhei Vit" Joint Stock Company acts based on implementation of modern facilities of BuckerUnipeKtin Company (Switzerland) of 10 million Euros with the purpose to satisfy high quality of products through processing annually 100 thousand tons of fruit. The company produces natural concentrate juice, high quality fruit puree for children from, cherries and grapes, that meet international requirements and is exported to 30 countries of the world [2].

The data of figure 2 demonstrates a share of import of 2-3 times higher than export which in 2013 represents the ratio of 69.4% compared to 30.6 of the export of the Republic of Moldova This situation is



considered negative.

The largest gap between the share of imports and exports has been certified since 2006, the period when the growth rate of exports of goods was restricted essential for well known reasons: the embargo imposed by the Russian authorities to import meat, vegetable products and wine from the Republic of Moldova.

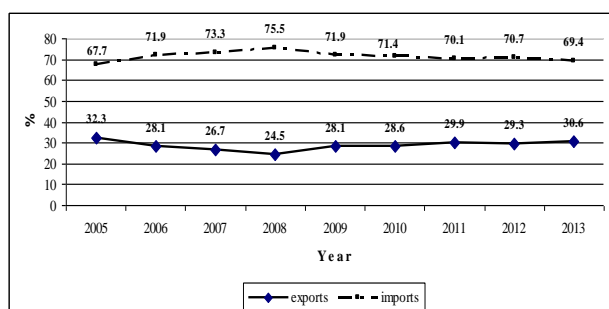

Fig. 2. The share of exports and imports in the external trade of the Republic of Moldova during 2005 – 2013. Source: processed by the authors based on data of the National Bureau of Statistics

The coverage level of imports through exports is also pointed out against unfavorable evolution of external trade, which from 2005 does not respect the minimum limits (60%) for ensuring economic security of the state, being continuously decreasing.

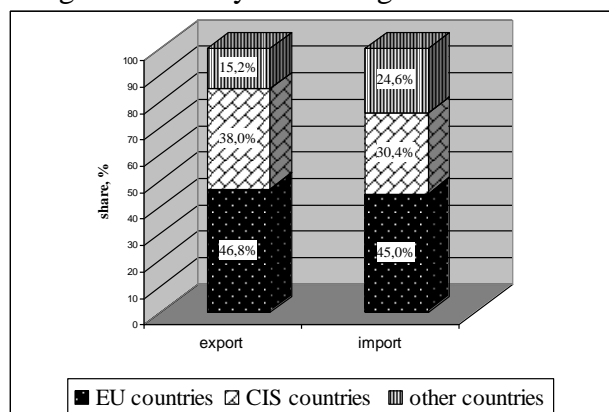

Fig. 3. The structure of exports and imports of the Republic of Moldova on groups of countries, 2013. Source: processed by the authors based on data of the National Bureau of Statistics.

The analysis of evolution of export and import structure demonstrates that the share of exports to CIS countries until 2008 including was more than 52%, with EU countries - up to 40% and other countries - 8-9%. Starting with 2009 was increased the share of exports and imports to EU countries, which already in

2013 (Fig.3) decreased the export and import with CIS countries to 30-38% and the EU countries and other countries increased to 45-46% and to 15-24.6% accordingly. Such a situation is explained by the fact that in 2006, 2011, 2012, 2013, 2014 were introduced embargoes to wine and other agro-food products (meat, vegetables, fruit, grain and flour, sunflower seeds, sugar, canned etc.) by the Russian Federation, being invoked inadequacy cases of phyto-sanitary requirements for quality products that actually refers to products inconsistency in international requirements of homogeneity products by size of fruit, vegetables, packaging etc.

The establishment by the Russian Federation of embargo on imports of meat, vegetable products (in May 2005) and wine (in March 2006) from the Republic of Moldova has stimulated Moldovan exporters' efforts to penetrate alternative markets for concerned products, including the markets of EU countries, countries - members of the multilateral free trade Agreement between countries of Central and Eastern Europe (CEFTA) and on the market more "nontraditional" as China, Japan etc.

The consequences of the embargo in wine industry were analyzed in 18 large companies operating on the Russian market. After the first embargos, the number of companies producing wine was decreased from 189 in 2005 to 141 in 2013. The embargo introduced in 2013 decreased the forecast incomes with 18.3 million dollars, and that of 2014 complicated the situation even worse, because on the Russian market the enterprises of this companies in export portfolio share of exports to Russian Federation was from 20% to 95%.

In the first quarter of 2014 missed incomes reached USD 15 million or 82% [5].

The data of table 1 demonstrates that the export of the Republic of Moldova from the main partner countries is dependent firstly of the Russian Federation, Romania, Italy, Ukraine, United Kingdom and Turkey. In external trade until 2011 was observed an improvement with the following countries: Ukraine, Russian Federation, Italy, France, Hungary, and Greece when export prevailed

import, influencing positive to reducing the trade balance of the country.

Table 1. Dynamic of export of the Republic of Moldova on some of the main partner countries, million dollars

Partner countries	Year				
	2009	2010	2011	2012	2013
<b>Total Export</b>	<b>1,283.0</b>	<b>1,541.5</b>	<b>2,216.8</b>	<b>2,161.8</b>	<b>2,428.3</b>
of which:					
Russian Federation	286.5	404.0	625.5	655.0	631.9
Romania	239.6	246.4	376.4	356.7	411.1
Italy	135.7	147.4	215.2	202.4	185.2
Ukraine	81.3	91.6	153.0	122.4	140.4
United Kingdom	60.3	82.1	101.7	83.9	105.5
Belarusi	80.7	80.3	75.6	80.7	90.3
Poland	33.9	46.7	85.9	74.2	85.3
Germany	75.5	75.4	106.4	70.2	113.1
Turkey	31.8	67.5	73.4	56.1	127.2
Kazakhstan	26.5	30.5	45.5	50.3	39.2

Source: processed by the authors based on data of the National Bureau of Statistics

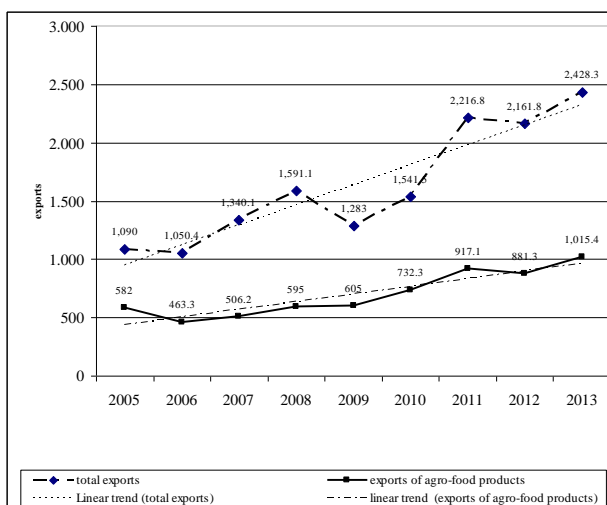

Fig. 4. The evolution and linear trend of total exports and exports of agro-food products from the Republic of Moldova, period 2005-2013.

Source: processed by the authors based on data of the National Bureau of Statistics

The analysis of evolution of export (Fig.4) and import (Fig.5) during 2005 - 2013 demonstrates an essential increase both for total exports and total imports, as well as agrarian and agro-food products.

The data presented in Figure 6 shows that the share of agro-food products in exports is significant, owning in the last period about 42 percent, which decreased compared to 2005 with about 11 percentage points.

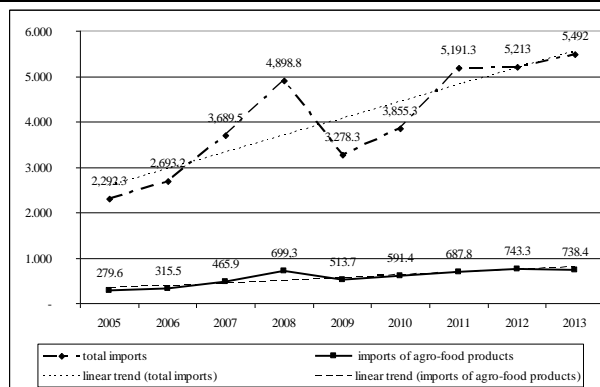

Fig. 5. The evolution and linear trend of total imports and imports of agro-food products in the Republic of Moldova, period 2005-2013.

Source: processed by the authors based on data of the National Bureau of Statistics

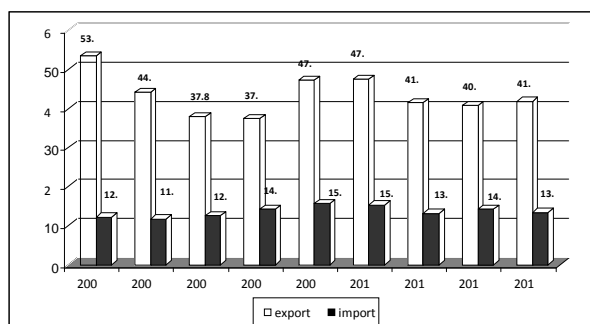

Fig. 6. The share of agrarian and agro-food products in total exports and imports of the Republic of Moldova, period 2005-2013.

Source: processed by the authors based on data of the National Bureau of Statistics

Once the share of agro-food products is decreasing in exports also was decreased their share in imports compared to 2009 from 15.3% to 13.4% - in 2013.

A retrospective view on the evolution of external trade of the Republic of Moldova (Tab. 2) highlights a 2.2 increase of exports in 2013 compared to 2005, including increase of agro-food exports - by 74%.

The growth rates of imports are higher than export growth. It shall be mentioned about a significant increase of import of agrarian and agro-food products, more that 2.1-2.6 times in the last four years of the analyzed period. Such a situation can be considered as a negative factor for an agrarian country like the Republic of Moldova.



Table 2. The growth rates (decrease) of imports and exports of the Republic of Moldova in the period 2005-2013

Indicator	Year								
	2005	2006	2007	2008	2009	2010	2011	2012	2013
Total exports	100	96	122	145	117	141	200	192	220
inclusive: exports agro-food products	100	79.4	87	102.2	104	125	157	151	174
Total imports	100	117	160	210	140	168	220	230	240
inclusive: imports agro-food products	100	112.8	166	250	184	210	250	260	264

Source: processed by the authors based on data of the National Bureau of Statistics

Further was determined the linear trend of the evolution of import and export (Tab.2) using first degree linear function.

Table 3. Trend of the evolution of import and export of the Republic of Moldova in the period 2005-2013

Indicator	Linear trend equation $\bar{N}_t = a_0 + a_1t$	The average level for the period 2005-2013	The forecasted level of 2018	The data 2018 year in% from the average for the period 2005-2013
Total exports	$\bar{N}_t = 1634 + 175.4t$	1,634	3,211	196
Including: exports agro-food products	$\bar{N}_t = 700 + 65.7t$	700	1,288	183
Total imports	$\bar{N}_t = 4066 + 372t$	4,066	7,414	182
Including imports agro-food products	$\bar{N}_t = 560 + 57.6t$	560	1,078	192

Source: authors' calculations

The analysis of the results of Table 3 demonstrates that both export and import has an increasing trend during 2005-2013 as follows:

-Total export annually increases in average with 175.4 million dollars, including 75.7 million dollars due to the contribution of agrarian and agro-food products. If this trend shall be kept, by 2018 the forecast level of exports shall be 321.1 million dollars, an increase of 96% and 83% respectively;

-Total import annually increases in average with 372 million dollars, including that of agro-food products – with 57.6 million dollars. By keeping these growth rates, by 2018 the forecast level shall be around 741.4 million dollars, exceeding about 3 time the forecast level of export.

## CONCLUSIONS

The analysis of evolution of external trade of the Republic of Moldova during 2005-2013 demonstrates an increasing trend with higher rates of import of agro-food products to their export and with a negative balance of trade balance.

The results of annual average evolution for 2005-2013 regarding the external trade followed the trends of previous years towards deterioration of trade balance of balance. Thus, in 2013, the external imbalance derived from the report between exports and imports of goods and services exceed the threshold of 3.064 billion, exceeding with 54% the level of 2009, but an insignificant increase (0.4%) compared to previous year.

In paper was performed the analysis of external trade of the Republic of Moldova with main groups of countries (EU, CIS and other countries). From this perspective, the evolution of the share of these groups of countries in structure of total volume of external trade of the Republic of Moldova registered during the last decade important structural “mutations”. In this regard, the main trend is that of continuous diminishing of the share of CIS countries in favor of other groups, especially those from European Union and other countries. Moreover, starting with 2008, it can be seen from EU side (from CIS countries) taking the position of leader in “ranking” of main trading partners of the Republic of Moldova.

According to these conditions, the reorientation/diversification in geographical profile of exports of the Republic of Moldova, especially providing a certain effective jump (quantitative and qualitative) thereof to EU and other countries from the world, is a priority concern both for producers and for the Government of the Republic of Moldova.

## REFERENCES

- [1]Ackerman, F., Stanton, E. A., 2013, Climate Impacts on Agriculture: A Challenge to Complacency? Global Development and Environment Institute, Tufts University, Working Paper nr. 13-01, 2013
- [2]Agricultural and rural policy: standards development. European Experiences for Moldova,

Asociația ProRuralInvest, Republica Moldova, Centrul de Consultanță, 2012. 110 p.

[3]Conway, G., Toenniessen, G.2003, Science for African Food Security. Science, 2003, No.299 (5610), pp. 1187 – 1188.

[4]Eastwood, R., Lipton M., Newell A., 2010, Farm Size. In Handbook of Agricultural Economics, Vol. 4, ed. Robert Evenson and Prabhu Pingali. Amsterdam: North Holland

[5]Statistical Yearbook of the Republic of Moldova. – Ch.: Statistica, 2013

[6]The contribution of economic activities in the formation of production volume  
<http://statbank.statistica.md/pxweb/Dialog/varval.asp?ma=CNT0102&ti=%2C++19952013&path>

md/pxweb/Dialog/varval.asp?ma=CNT0102&ti=%2C++19952013&path

[7]Turek Rahoveanu, A., Turek Rahoveanu, M. M., 2013, Socio-economic development prospects of rural areas in the context of application of leader program in Romania. Scientific Papers. Series "Management, Economic Engineering in Agriculture and rural development", Vol. 13(4): 295-302.

## THE SPATIAL CONCENTRATION AND SPECIALIZATION OF AGRICULTURAL PRODUCTION IN EU

Agnieszka TLUCZAK

Opole University, Faculty of Economics, 46 a, Ozimska Str., Opole, 45-058, Poland, Phone: +48 692921133, Email: atluczak@uni.opole.pl

*Corresponding author:* atluczak@uni.opole.pl

### *Abstract*

*Agriculture is a very specific sector of the economy, significantly different from other economic activities. One of the main distinguishing characteristics of agricultural production is its surface character and strong dependence on environmental conditions, especially the nature. These conditions determine to a large extent on the structure of crops and livestock, but it is not completely determined. Therefore, it seems reasonable, taken in this article, an attempt to show concentration and specialization of agricultural production in the EU. The aim of this article is to attempt to identify the main trends in the spatial concentration of agricultural production in the EU. Another objective is to determine the specialization of individual member states in types of agricultural production. The study used location factor (LQ), which can also be used to study the concentration and specialization of region. The main results show there is a concentration of agricultural production in the EU and there are the countries specializing in a particular types of agricultural production. The analysis will be conducted on the basis of data taken from the Central Statistical Office of Poland. The analysis is conducted for the years 2005, 2010, 2012.*

*Key words:* agriculture production, concentration, specialisation

### INTRODUCTION

EU membership means that agriculture of each country is influenced by Common Agricultural Policy and is subject of competition by other countries. At the same time, agriculture in each country retains its identity and specificity. This is reflected in the natural conditions of agricultural production, the role of agriculture in the economy, as well as factors of production resources and their performance [10]. Currently it can be noted the general trends of changes in the direction of reducing the number of farms. In this same time the growth of surface production units, can be observed. This changes are slow processes and mechanisms are required to start the stimulus so at EU level and at national level [2]. The regional diversity of agriculture in European Union is discussed by Tłuczak, where the issues of similarities the level of development of agriculture are discussed [16, 17, 18,19, 21].

The subject of this study is related to the analysis of spatial concentration and specialization of agricultural production in the European Union. The main aim of this study

is therefore to answer the following questions:

(1) Whether there is and how strong is the concentration of individual major types of agricultural production in the EU; (2)What is the nature of this production in the distinguished spatial units. The analysis will be conducted on the basis of data taken from the Central Statistical Office of Poland. The analysis is conducted for the years 2005, 2010, 2012.

The specialization and the concentration sometimes are treated as connected processes and even identical. If at the theoretical level their connection depends on theories which we take into account, at the empirical level the analysis of the diverse economic activities use the same data for the specialization and the concentration. Most of the empirical studies treat both processes as parallels, that is the dynamics of the specialization is always accompanied with the same dynamics of the concentration [3].

The phenomenon of the regional specialization generated a considerable interest among the economists, the geographers and the historians. Since Adam Smith's major work the specialization was

connected with the regional development and the economic growth [5].

The theoretical literature on location theory and the spatial consequences of economic integration has by now become very voluminous, encompassing elements of trade theory, growth theory, urban economics and economic geography [13].

Economic theories are far from being able to explain or even predict the changing specialisation and concentration patterns. Different models from (new) trade, (new) growth and (new) economic geography come to distinct conclusions, depending on their assumptions, a possible change of parameters in time, mobility patterns, transaction costs and the extent to which variables are endogenous. Consequently, empirical work should shed some more light on the European economic landscape [11, 12].

Specialization of countries in particular sectors and concentration of economic phenomena in regions or countries have long been treated as closely related economic phenomena, if not identical [1]. In Polish literature the subject of spatial concentration and specialisation is considered i.a. by Szewczyk, Łobos, Thuczak [8, 9, 15, 16, 20].

The definitions of both regional specialisation and geographic concentration are based on the same production structures, reflecting the same reality. Regional specialisation expresses the territorial perspective and depicts the distribution of the shares of the economic activities in a certain region, usually compared to the rest of the country, while geographic concentration of a specific economic activity reflects the distribution of its regional shares [6]. Although the bulk of the literature on specialization and concentration implicitly or explicitly treated these two phenomena as interrelated, there are some empirical outcomes suggesting they would rather be considered as independent processes since they “might not in all cases move in the same direction, and are probably going to take place at different speeds”. Furthermore, the model in Rossi-Hansberg [1] was used for empirically proving that specialization and concentration may even go in opposite directions when transport costs

change. More specifically, as transport costs lower the degree of concentration tend to increase, while the level of specialization decrease [1].

## MATERIALS AND METHODS

There are many standard statistical indices of dispersion which might be employed to measure the specialization and concentration. Location quotients can be interpreted as a local measure of geographical concentration of industries. They are calculated as the quotient between the local share of value of specific agriculture production and the local share of global value of specific agriculture production. Location quotients is given by formula:

$$LQ = (E_{i,r} / E_i) / (E_r / E)$$

where  $E_{i,r}$  is the value of agriculture production sector  $i$  region  $r$ ,  $E_i$  is the value of agriculture production in sector  $i$ ,  $E_r$  is the value of agriculture production in region  $r$  and  $E$  is the value of agriculture production in EU.

A value of 1 means that region  $r$  has the same share of agriculture production in sector  $i$  as its share of global value of agriculture production.

A value greater than 1 means that region  $r$  has a higher share of value of agriculture production in sector  $i$  than its share of global value of agriculture production [8, 9, 15, 19, 20, 21].

Location quotients can also be interpreted as a local measure of sector specialisation for local areas. They compare for each sector of agriculture production the sector's share of local area value of agriculture production with its share of global value of agriculture production. In this case location quotient is given by this same formula as in the case of the concentration, but the interpretation is slightly different:

$$LQ = (E_{i,r} / E_r) / (E_i / E)$$

where  $E_{i,r}$  is the value of agriculture production in sector  $i$  region  $r$ ,  $E_r$  is the value of agriculture production in region  $r$ ;  $E_i$  is the value of agriculture production in sector  $i$ , and  $E$  is the global value of agriculture production in EU.

A value of 1 means that an sector's share of value of agriculture production in region r is the same as its share of global value of agriculture production in EU. A value greater than 1 means that sector i makes up a larger share of value of agriculture production in the local area than at the global (EU) level [8, 15]. The research hypotheses can be stated as follows:

H1: there is a concentration of agricultural production in the EU;

H2: there are the countries specializing in a particular direction of agricultural production;

H3: CAP intervention's instrument conducive to concentration and specialisation of agriculture production. The analysis will be conducted on the basis of data taken from the Central Statistical Office of Poland. The analysis is conducted for the years 2005, 2010, 2012.

## RESULTS AND DISCUSSIONS

The employment in sectors is the most frequently used in research of specialisation and concentration. In this study the value of agricultural production in euro per 1 dt for crops or animal for slaughter were used to determine the specialization of agricultural production in the member states of the European Union. The agricultural production were considered broken down by crop and animal. The crop production for the production of wheat, rye, barley, potatoes, sugar beets and animal production - beef, pigs and poultry.

LQ ratios were calculated for each the European Union countries, taking as a reference area the whole Union. This made it possible to determine the spatial diversity of concentration and specialisation in the various sectors of agricultural production in the EU. LQ index using an analysis of the concentration local agricultural production across the EU. Data on the degree of concentration of individual countries in separate sectors of agricultural production present table 1.

Due to the crop production the smallest concentration was observed in the case of Portugal and the Netherlands.

Table 1. Location quotient results for sectors of agricultural production\*

		LQ <1	LQ > 1
2005	crop	PT, MT, CY, SI, ES, IE, NL, BE, IT, DK, AT, LU	DE, HR, PL, HU, UK, FI, SE, EE, FR, RO, EL, CZ, SK, T, BG, LV
	animal	LV, BG, LT, SK, CZ, EL, RO, FR, EE, SE, FI, UK, HU, PL, HR, DE	LU, AT, DK, IT, BE, NL, IE, ES, SI, CY, MT, PT
2010	crop	PT, CY, IE, SI, MT, IT, BE, ES, NL, AT, DK, DE	PL, HR, HU, FI, LU, UK, SE, EE, EL, RO, FR, SK, CZ, LT, LV, BG
	animal	BG, LV, LT, CZ, SK, FR, RO, EL, EE, SE, UK, LU, FI, HU, HR, PL	DE, DK, AT, NL, ES, BE, IT, MT, SI, IE, CY, PT
2012	crop	PT, CY, NL, IE, MT, BE, ES, SI, IT, AT, DK, DE	PL, LU, HU, UK, FI, EL, RO, HR, SE, FR, EE, CZ, SK, LT, LV, BG
	animal	BG, LV, LT, CZ, SK, FR, RO, EL, EE, SE, UK, LU, FI, HU, HR, PL	DE, DK, AT, IT, SI, ES, BE, MT, IE, NL, CY, PT

\* due to the limitations of the work, instead of the full names of countries the codes were used on the basis of <http://publications.europa.eu/code/pl/pl-370100.htm>

These are countries that reach one of the highest values LQ in animal production. After all, these are the countries which are experiencing a continuous growth of production in this area. When analyzing the distribution of crop production in wheat, barley, rye, potatoes and sugar beet we can say that Poland, Hungary and Austria are the countries where the greatest concentration of production of rye and sugar beet. Hungary and Italy have specialized in the production of wheat, and Spain in the production of barley. Considering livestock production in order to split the production of beef, pork and poultry should be noted that Portugal and Ireland are the countries where the greatest concentration of modality and thus specialization, beef and pork.

Breeding pigs in Europe and the market for pork is one of the least controlled using the

mechanisms of the Common Agricultural Policy. There is no surcharge direct market intervention and instruments are used occasionally. Besides, technological characteristic of this type of production (mainly the high fertility of sows and fattening relatively short period of time) are conducive to significant fluctuations in the level of production, which in turn translates into fluctuations in pricing. Therefore, both in the EU countries predominate numerically relatively small holdings keeping the herd with this is that new countries are mainly entities with 1 or 2 pieces (in 2010 there were almost 70%). This should be associated with a greater role of self-supply in countries where agriculture standing on the lower level of development, characterized by both lower marketable. As with other fields of animal production, the number of holdings with sheep decreased between 2005 and 2010. Only in Ireland, there was a 35% increase. Despite the reduction in the number of holdings with cattle (about 30% in the EU-27), in 2005-2010 the number of cattle in the Member States only reduced by less than 3%, with similar trends in new and old Member States, which in itself indicates the processes of concentration. These reasons connected with the need to meet the standards have contributed to the reduction of entities with small-scale farming, and consequently to reduce the number of stocks held by them. This process of concentration is also evident in the case of changes in the average herd of cattle, which has increased in almost every country (except in Ireland, where it remained almost unchanged, although a high level).

## CONCLUSIONS

Almost all the EU member states have increased the value of agricultural production. The highest dynamics occurred in Poland, Estonia, the Czech Republic and Romania. In the years 2005, 2010, 2012, the share of countries adopted in 2004, the EU plant and animal production. Trends that occur in the structure of production in the EU are reflected in agricultural production in each country separately. Note the decrease in the

production of cereals, sugar beet and potatoes. The subordination of agriculture in all countries the rules of the CAP, as well as the processes of globalization causes the changes in the level and structure of agricultural production are member countries coincide. There is a tendency to specialize in agricultural production of selected EU countries. In countries where growing environmental requirements of fattening animals, and land prices are high (Denmark, the Netherlands, Belgium), the focus on the production of piglets. In turn, in the central and eastern parts of Europe (including Poland and Germany) expands specialization in fattening pigs. Concentration of pig production varies considerably at EU countries. Highest occurs in Denmark, the Netherlands and Belgium, by far the lowest in Poland. At the same time in all the countries surveyed, there was a increase in the concentration of production, although the pace of this process is different.

## REFERENCES

- [1]Aiginger K., Rossi-Hansberg E., 2004,Specialization versus concentration: A note on theory and evidence, [http://karl.aiginger.wifo.ac.at/fileadmin/files\\_aiginger/publications/2004/esteban.pdf](http://karl.aiginger.wifo.ac.at/fileadmin/files_aiginger/publications/2004/esteban.pdf)
- [2]Babiarz J., 2010, Zmiany w strukturze rolnictwa krajów Unii Europejskiej, Rocznik Integracji Europejskiej, no 4/ 2010.
- [3]Ceapraz, I. L., 2008, The concepts of specialisation and spatial Concentration and the process of economic Integration: theoretical relevance and statistical measures. The case of Romania's regions. The Journal of the Romanian Regional Science Association, Vol. 2, No. 1.
- [5]Dunn, E.S., Lampard, E.E., Muth, R.F., Perloff, H.S., 1960, Regions, Resources and Economic Growth, Lincoln: University of Nebraska Press, 1960.
- [6]Goschin, Z. et al., 2009, Specialisation and concentration patterns in the Romanian economy, Journal of applied quantitative methods, vol. 4 no. 1
- [7]Goschin, Z., Constantin, D., Roman, M., Ileana B., 2009,Regional specialization and geographic concentration of industries in Romania, South-Eastern Europe Journal of Economics 1
- [8]Łobos K., Szewczyk M., 2013, Dystrybucja efektów koncentracji sektora piwowarskiego wśród dużych i małych przedsiębiorstw operujących na rynku polskim w latach 2004-2011. Journal of Agribusiness and Rural Development, Zeszyt 4 (3)
- [9]Łobos, K., Szewczyk, M., 2014, The Sugar Market in Poland: the Economic Results of Sugar Producers in

the Years 2006-2012, GV-Conf 2014, EDIS - Publishing Institution of the University of Zilina.

[10]Nowak, A., 2011, Zmiany wydajności rolnictwa Polski i innych krajów Unii Europejskiej, Problemy Rolnictwa Światowego, Vol. 11(26), Issue 1, 130-132

[11]Schütz, U., 2003, Regional specialisation and sectoral concentration: an empirical analysis for the enlarged EU, Trier University, Germany

[12]Stierle, M., 2003, European Commission, Brussels, Belgium, <https://www.jyu.fi/ersa2003/cdrom/papers/317.pdf>

[13]Suedekum, J., 2004, Concentration and Specialisation Trends in Germany since Reunification, HWWA DISCUSSION PAPER, Hamburg Institute of International Economics No. 285, European Regional Science Association 2003 Congress

[14]Szewczyk, M., 2014, High-Growth Enterprises in Poland: A Regional Comparison with Special Emphasis on Opolskie Voivodship, GV-Conf 2014, EDIS - Publishing Institution of the University of Zilina.

[15]Szewczyk, M., Tłuczak, A., 2012, Economic Base of Opolskie Voivodship, 2008-2010, [w:] Ad Alta, Journal of Interdisciplinary Research, Issue 1, vol. III

[16]Tłuczak, A., 2013a, The analysis of the phenomenon of spatial autocorrelation of indices of agricultural output, Metody Ilościowe w Badaniach Ekonomicznych, vol. XIV, No 2.

[17]Tłuczak, A. 2013, Spatial autocorrelation of indices of agricultural output in EU, QUAERE vol. III

[18]Tłuczak, A., 2014, Regionalne zróżnicowanie cen żywności w skupie w Polsce w latach 2005-2012, Journal of Agribusiness and Rural Development, nr 1(31).

[19]Tłuczak, A., 2014, Zastosowanie modelu potencjału w analizie zróżnicowania regionalnego rolnictwa w krajach Unii Europejskiej, Metody Ilościowe w Badaniach Ekonomicznych, Tom XV/4, 2014.

[20]Tłuczak, A., 2010, Market Concentration – methods of measurement on the basis of telecommunication market in Poland. in: Market concentration and economy. Red. T. Bernat. Wyd. Uniwersytetu Szczecińskiego, Szczecin.

[21]Tłuczak, A., 2014, Zróżnicowanie przestrzenne dynamiki produkcji rolnej w krajach Unii Europejskiej, [in:] Problemy społeczno-ekonomiczne w relacjach międzynarodowych. Analiza modelowa rozwoju regionów, Uniwersytet Ekonomiczny.





## IMPROVING THE SYSTEM OF PUBLIC SUPPORT AND MECHANISMS TO STIMULATE INNOVATION IN AGRICULTURE

Liudmila TODOROVA

State Agrarian University of Moldova, 42 Mircesti Str., sector Rascani, Chisinau, MD-2049, Republic of Moldova, Phone: +373 22 432387, E-mail: liudmila.tod@gmail.com

### Abstract

*In most countries and regions in the scientific community is increasingly a question about the level of economic development of the primary and secondary branches of national economy. Here the degree involvement in the innovation process is no less important aspect of sustainable development of small and medium-sized enterprises, in particular, engaged in agricultural production, which is now regarded as generators of the most innovative ideas, implementing successful innovation projects. But, most of the financing of innovative projects in the Republic of Moldova at the expense of public funds, and to a lesser extent with additional private or foreign investments. Therefore, is required a deep analysis of the composition and structure of the innovation environment in the country and develop a mechanism for enhancing innovation through the effective interaction of significant economic and political instruments. The article draws on statistical and economic research methods. The main methods of processing and analyzing statistical data are: economic grouping, comparison and analysis of variance. Research results indicate the need for the formation of venture investment in the innovation process through the development and adoption of the corresponding legal and regulatory framework, and the establishment of closer ties between private entrepreneurship and the scientific community.*

**Key words:** economic development, enhancing innovation, innovation projects, venture financing.

### INTRODUCTION

The innovation process is of vital importance for the socio-economic development of the country under the current conditions of economic globalization. Therefore, the economic development, the level of competitiveness and social welfare in the Republic of Moldova is highly dependent on the social ability to innovate.

In order to support the innovation process in Moldova there have been created certain prerequisites necessary for the innovation development by establishing and improving the legal framework that regulates innovation activity and ensures the strategic basis of the innovation concept and technology transfer as well as other accompanying activities. There have been established the corresponding mechanisms to implement innovation projects, to transfer and develop new technologies, products and services.

### MATERIALS AND METHODS

The documentary basis of these studies is legislative and regulatory acts of the Republic of Moldova. To regulate the scientific,

research and innovation activity there was adopted the Code on Science and Innovations of the Republic of Moldova no. 259-XV of July 15, 2004 [4]. A new vector in the development of the Innovation Policy of the Republic of Moldova was the Innovation Strategy 2013-2020 “Innovations for competitiveness” no. 952 of November 27, 2013 [6], developed to implement the Program on the Government Activity “European Integration: Freedom, Democracy, Welfare” 2013-2014 and the Plan on the Government Activity of the Republic of Moldova no. 289 of May 7, 2012 (Official Monitor no. 93-98, 2012, p. 330) [5]. The strategy defines the basic directions and factors of the innovation development of the Republic of Moldova till 2020. Hence, the main implementation objective of this document is to improve the economic, political and social competitiveness of the country at the international level.

The research methodology is based on the use of analytical and mathematical tools of analysis. To prove the ideas stated in the article there have been used the methods of dialectical, systematic, functional, static

(correlative and regressive) and comparative analysis.

## RESULTS AND DISCUSSIONS

In 2004 there was established the Agency for Innovations and Technology Transfer, part of the Academy of Sciences of the Republic of Moldova, at the initial stage of the process of the national innovation system development in order to stimulate, coordinate and implement the necessary mechanisms and to use the corresponding tools in the field of innovations and technology transfer. The main objective of this institution is to be a link

between the scientific environment, authorities and business - their engagement is necessary to make the innovation system function efficiently and to ensure the competitiveness of the country's economy at the international level [7].

The Agency is the significant part of the national innovation infrastructure that should play an important role in the innovation economy development, ensuring the country's competitiveness at the international market. Innovation infrastructure also includes hi-tech parks, innovation incubators, scientific and research centres and economic agents [8].

Table 1. The main performance indices of hi-tech parks (HTPs) and innovations incubators (InnIncs) in the Republic of Moldova in 2013

The name of the HTP/InnInc	The number of IPs implemented within HTPs/InnInc	The number of working places		The total amount of wages within the project (Lei thou)	Investments (Lei thou)	including:		the cost of realized products (Lei thou)	including : Export (Lei thou)	The number of residents	
		Total	New			from the state budget (Lei thou)	from abroad (Lei thou)			Total	New
HTP "Academica" (together with InnInc Inovatorul)	6	166	14	1,047	422	18	0	23,833	2,500	15	-
HTP "Inagro"	-	-	-	-	-	-	-	-	-	13	1
HTP "Micronanoteh"	4	41	23	321.60	1,703.6	367.65	0	0	0	3	2
InnInc "Politehnica"	-	-	-	-	-	-	-	-	-	-	-
InnInc "Inventica-USM"	-	-	-	-	-	-	-	-	-	-	-
InnInc "Itech"	-	-	-	-	-	-	-	-	-	-	-
InnInc "Nord"	-	-	-	-	-	-	-	-	-	-	-
InnInc "Innocenter"	3	17	9	134.6	570.0	225.3	0	473.76	0	2	2
InnInc "Antreprenorul Inovativ"	0	61	44	544.2	2,636.8	1,123.6	0	2,646.0	0	6	3
<b>Total</b>	<b>13</b>	<b>285</b>	<b>90</b>	<b>2,047.4</b>	<b>5,332.4</b>	<b>1,734.55</b>	<b>0</b>	<b>26,952.76</b>	<b>2,500</b>	<b>39</b>	<b>8</b>

Source: developed by the author based on the AITT data.

At present there are 3 hi-tech parks and 7 innovation incubators in the Republic of Moldova, which improve the efficiency of research results implementation, provide consumers with competitive industrial products, work and services, based on innovation. They include 39 resident companies, selected on the competitive base and approved by the High Council for Science and Technology Development of the Academy of Sciences of the Republic of Moldova. In spite of the fact that there are 8 clusters within the innovation infrastructure of the Republic of Moldova, the first scientific and research cluster in the field of modern technologies "Elchim-Moldova" was

established in 2013. Ten partners have concluded the association agreement: 4 universities, 3 scientific and research institutions, the factory "Topaz", AITT and the Academy of Sciences of the Republic of Moldova in order to ensure the cooperation between businessmen and scientists [1]. The cluster in the field of nanotechnologies and IT was founded in 2014 and is at the stage of development. This proves that scientists are interested in the improved innovation process in the country, but the business society should be more interested in the implementation of the corresponding partnership.

Yearly the Agency for Innovations and Technology Transfer of the Academy of

Sciences organizes a competition on innovation projects and technology transfer; the state funds up to 50% of the total project cost. Implementation of innovations or new technologies is the mandatory condition of project realization. The period of innovation and technology transfer project implementation is no more than 2 year. Research shows that the number of projects varies from year to year. In 2007 and 2010 there were registered the greatest numbers of implemented projects, but there was observed gradual reduction, which is related to the decreased funds of innovation projects, the unstable economic and political situation both in the country and abroad. There were selected 40 projects on innovations and technology transfer on the competitive base in 2013, 22 of them were funded (Lei Million 6.82 from the state budget and Lei million 9.58 from the private sector) and implemented.

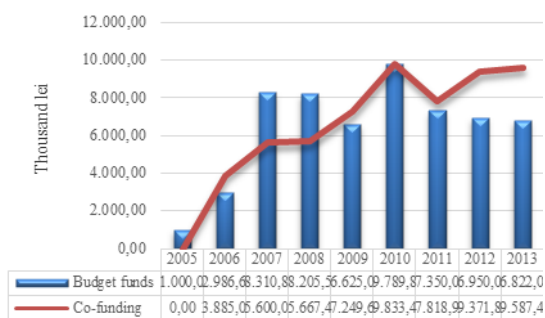

Fig. 1. The funding dynamics of innovation projects in 2005-2013

Source: developed by the author based on the AITT data.

The structural vision of the general situation regarding the funding of the innovation development of the country is formed based on the provided data. One can notice that the share of private funds was being gradually increased and reached its maximum value in 2010. At the same time, public funds for innovations and technology transfer are significantly decreased.

The structural dynamics of the number of funded projects industry-wise changes every year, depending on the existing conditions at the country's internal market.

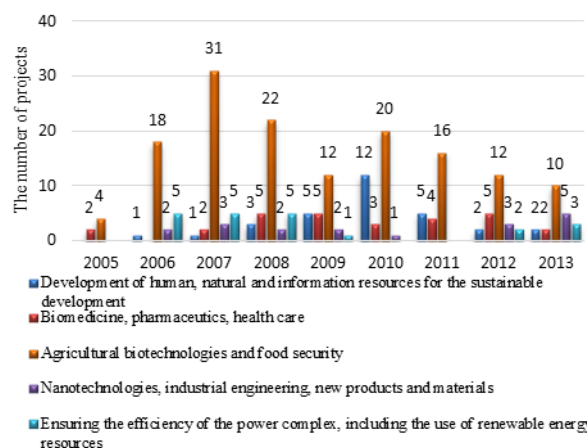

Fig. 2. The dynamics of implemented innovation projects industry-wise in 2005-2013, units.

Source: developed by the author based on the AITT data.

The number of projects in agriculture has significantly decreased over the past 4 years since 2010, which is the consequence of the decreased public funds and agriculture is the branch of the economy that directly depends on public funds. At the same time one can notice the increased number of projects on nanotechnologies, industrial engineering, new products and materials. Taking into account that there were no projects in this field in 2011, their number increased to 5 in 2013.

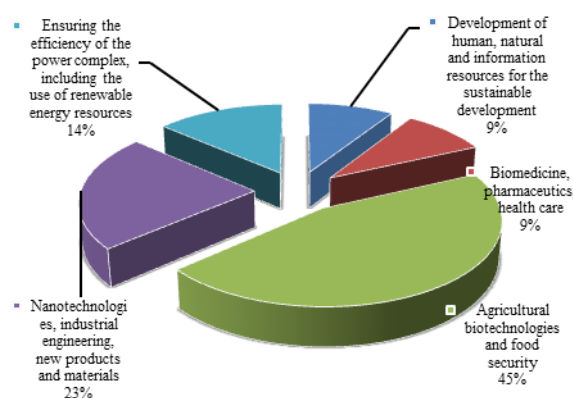

Fig. 3. The funding structure of innovation projects industry-wise in the Republic of Moldova in 2013

Source: Own determination.

The biggest share of innovation and technological projects funding is observed in agriculture, where the average funding is more than 50% of the total funded projects in 2005-2013. In 2013 there were allocated 45% of the total funds for the projects in this field. The next strategic development in 2013 is

“Nanotechnologies, industrial engineering, new products and materials”, then goes the direction “Ensuring the efficiency of the power complex and power security, including the use of renewable energy resources”, afterwards – the direction “Biomedicine, pharmaceuticals, health care” and the least funded direction is “Development of human, natural and information resources for the sustainable development”.

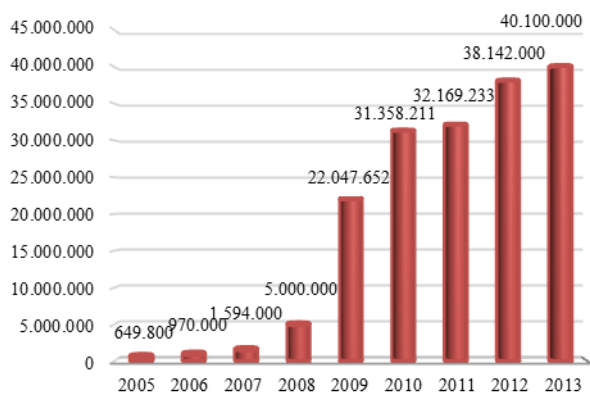

Fig. 4. The volume of realized innovation products in 2005-2013 by innovation projects and technology transfer.

Source: Own calculation.

Funding and project implementation result in innovation products that are introduced into the market; they influence the level of social and economic development of the country. Despite the decreased public funds in 2010-2013, the rate of production and implementation of innovation products is constantly increasing in the country during the studied period. At the same time external funding of the innovation activity is yearly increased, though the state’s engagement in this activity funding is still more stable in the Republic of Moldova.

One should measure the interconnection between the funding of innovation processes as a result of the project implementation and the amount of revenues received from innovation products sale to determine the earnings gain from investments.

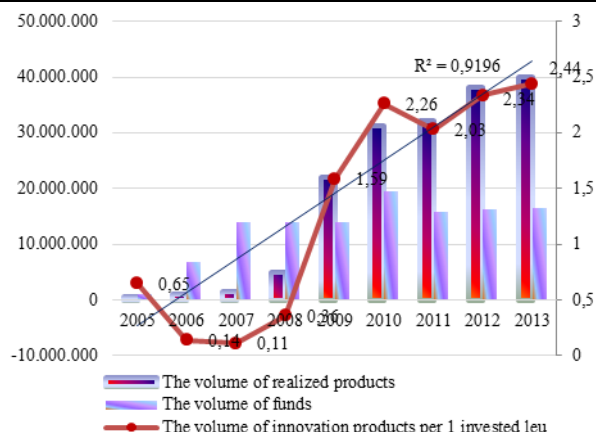

Fig. 5. The dynamics of public funds, output and realization of innovative products, MDL.

Source: Own calculation.

So, we have:

$V$  – specific volume of innovation products;  
 $V^{(m)}$  – the most possible specific volume of innovation products;

$\frac{\partial V}{\partial t}$  – the increased specific volume of innovation products per unit of time (the intensity of innovation products growth through time).

It is not identified that the increased specific volume of innovation products per unit of time ( $\frac{\partial V}{\partial t}$ ) depends directly on the achieved specific volume of innovation products ( $V$ ) and with the possible potential ( $V^{(m)} - V$ ). Formally this dependence may be expressed as a differential equation with separable variables [3]:

$$\frac{\partial V}{\partial t} = AV(V^{(m)} - V) \tag{1}$$

To solve this equation one needs to find:

$$V = \frac{V^{(m)}}{1 + e^{AV^{(m)} \cdot t \cdot V_0}}; \tag{2}$$

$$P(x, y) dx + Q(x, y) dy = 0 \tag{3}$$

According to N. Kremer, if the equation (2) after transformation can be presented as the equation (3), then it is the equation of separable variables [2]. We exclude the points where the functions  $\varphi_1(y) = 0$  and  $f_2(y) = 0$ . Then, by dividing both sides of equation (3) on  $\varphi_1(y)f_2(y)$ , we obtain the following equation:

$$\frac{f_1(x)}{\varphi_1(x)} dx + \frac{\varphi_2(y)}{f_2(y)} dy = 0 \tag{4}$$

The variables in this equation are reduced and

the general solution of the equation is the following:

$$\int \frac{f_1(x)}{\varphi_1(x)} dx + \int \frac{\varphi_2(y)}{f_2(y)} dy = C$$

We use this method to solve the differential equation (1), that is we are going to divide both parts of the equation by  $V(V^m - V) \neq 0$ :

Afterwards, we receive:

$$\frac{dV}{V(V^{(m)} - V)} = Adt \tag{5}$$

where:

A- the proportionality coefficient.

Then we have to transform the left part of the differential equation (5):

$$\frac{1}{V^{(m)}} \cdot \left( \frac{dV}{V} + \frac{dV}{(V^{(m)} - V)} \right) \tag{6}$$

The general integral of this differential equation is:

$$\int \frac{dV}{V} + \int \frac{dV}{V^{(m)} - V} = AV^{(m)} \int dt$$

The general solution of the differential equation:

$$\ln V - \ln |V^{(m)} - V| = AV^{(m)} t + C$$

Therefore:  $\frac{V}{V^{(m)} - V} = e^{AV^{(m)}t} \cdot e^C$

Further we find the partial solution of the equation which complies with the initial conditions, that is if  $t = 0, V$  is defined as  $V_0$ :

$$\frac{V_0}{V^{(m)} - V_0} = e^{AV^{(m)} \cdot 0} \cdot e^C \Rightarrow e^C = \frac{V_0}{V^{(m)} - V_0};$$

Therefore:

$$\frac{V}{V^{(m)} - V} = e^{AV^{(m)} \cdot t} \cdot \frac{V_0}{V^{(m)} - V_0};$$

$$V = \frac{e^{AV^{(m)} \cdot t} \cdot \frac{V^{(m)} \cdot V_0}{V^{(m)} - V_0}}{1 + e^{AV^{(m)} \cdot t} \cdot \frac{V_0}{V^{(m)} - V_0}}; \tag{7}$$

Then, we transform the equation (7) by dividing on  $e^{AV^{(m)} \cdot t} \cdot \frac{V_0}{V^{(m)} - V_0} \neq 0$ :

$$V = \frac{V^{(m)}}{1 + \frac{1}{e^{AV^{(m)} \cdot t} \cdot \frac{V_0}{V^{(m)} - V_0}}} = \frac{V^{(m)}}{1 + \frac{V^{(m)} - V_0}{e^{AV^{(m)} \cdot t} \cdot V_0}}$$

The volume of innovation products per 1 invested leu in 2006 is  $V_0=0.14$ , that is if in 2006 the initial  $t=0, V=0,14$ . So,

$$V = \frac{V^{(m)}}{1 + \frac{V^{(m)} - 0.14}{0.14 \cdot e^{AV^{(m)} \cdot t}}}; \text{ if } t \rightarrow \infty V = V^{(m)} = 3.$$

Further, we have to calculate the sums to find out the linear regression coefficient when determining the dependence degree of the innovation processes funding volume and the output of innovation products:

**Table 2.** The value calculation to determine the parameters of the linear regression equation

Years	The volume of funds $X_i$	The volume of realized products $Y_i$	$X_i^2$	$X_i Y_i$	$Y_i^p$
2005	0.1	0.65	0.01	0.065	7.64
2006	6.9	0.97	47.61	6.693	21.59
2007	13.9	1.59	193.21	22.101	35.96
2008	13.9	5.00	193.21	69.5	35.96
2009	13.9	22.05	193.21	306.5	35.96
2010	19.6	31.36	384.16	614.6	47.66
2011	15.8	32.17	249.64	508.3	39.86
2012	16.3	38.14	265.69	621.7	40.89
2013	16.4	40.10	268.96	657.6	41.09
	$\sum x_i = 116.8$	$\sum y_i = 172.03$	$\sum x_i^2 = 1,795.7$	$\sum xy = 2,807.06$	-

Source: Own calculation.

The empiric line of regression is identified as result of the following function:

$$Y^p = a_0 + a_1 x \tag{8}$$

To define the parameters of the regression equation we calculate:

$$a_1 = \frac{n(\sum y_i x_i) - \sum y_i \sum x_i}{n(\sum x_i^2)}; \tag{9}$$

$$a_1 = \frac{25,263.54 - 20,093.104}{16,161.3 - 13,642.24} = 2.052$$

$$a_0 = \frac{1}{n} (\sum y_i - a_1 \sum x_i); \tag{10}$$

$$a_0 = 0.11 * (172.03 - 2.052 * 116.8) = 7.44$$

Thus, the sought regression dependence looks like:  $y^p = 7.44 + 2.052x$

The correctness of the developed linear regression equation, if necessary, may allow us forecasting the level of production and costs in the innovation activity. Moreover, one should identify the value of the changed elasticity of the studies indicators based on the equation of correlated regression:

$$E_x(y^{(p)}) = \frac{dy^{(p)}}{dx} \cdot \frac{x}{y^p} = \frac{2.052x}{7.44 + 2.052x};$$

The given elasticity coefficient shows that if indicator  $x$  is increased by 1%, and then indicator  $y^{(p)}$ , will be increased by  $\frac{2.052x}{7.44+2.052x}$  %.

To calculate the elasticity coefficient we should transform the equation:

$$\frac{2.052x}{7.44+2.052x} = 1 - \frac{2.052x}{7.44+2.052x} = E_x(y^{(p)});$$

If  $x=0$ , then  $E_x(y^{(p)})=1-1=0$ ;

If  $x \rightarrow 0$ , then  $E_x(y^{(p)}) \rightarrow 1$ .

## CONCLUSIONS

Conclusions of the author's study are the following:

Indicator  $y^{(p)}$  relatively to the indicator  $x$  is not elastic, ie there is no alternatives for public funding of innovative production in the Republic of Moldova in this phase of economic development.

Based on the value recorded in 2013, we conclude the following: for every 1 leu invested by public funds for innovative projects and technology transfer it was obtained 2.4 lei of innovative products.

Comparing the output and sales of innovative products in 2013 and 2005, we can conclude that with the growing of innovative products, at the same time increases the interest of the private sector in the financing of innovative projects and as a result increases the innovative potential of the national economy.

It is necessary to encourage innovation in the country with the following measures:

- tax incentives for research, public funding of research in agricultural enterprises;
- promoting linkages between science and the public sector enterprises;
- the agreement with industry and agriculture on training through research.

## REFERENCES

- [1]Agency for Innovation and Technology Transfer, 2014, www.aitt.md.
- [2]Kremer, N. S., 2012, Higher Mathematics for Economists. Practical work. Moscow: Unity Dana.
- [3]Maximilian, S., Gribincea, A., Todorova, L., 2014, Justificarea perspectivelor de dezvoltarea a activității inovative. Chișinău: Economie și Sociologie. No.3
- [4]Monitorul Oficial al Republicii Moldova, no.1, 2004, Codul Nr. 259-XV din 15.07.2004 cu privire la știință și inovare al Republicii Moldova.
- [5]Monitorul Oficial al Republicii Moldova, No.9, 2012, Programul de activitate al Guvernului RM „Integrarea Europeană: Libertate, Democrație, Bunăstare” 2013-2014.
- [6]Monitorul Oficial, No.2, 2013, Strategia inovativă a RM pentru perioada 2013-2020 „Inovații pentru competitivitate”.
- [7]Todorova, L., Gribincea, A., 2012, The importance of competitiveness of the country to counter the economic crisis. Scientific Papers. Series "Management, Economic Engineering in Agriculture and rural development", Vol. 12.
- [8]Todorova, L., Gribincea, A., 2013, Effects of innovation development on the international competitiveness of European countries. Tbilisi: International Collection of the Scientific Works. International business in the world economic system. Publishing House "Universal".



## STRUCTURAL CHANGES AND ECONOMIC RESILIENCE IN ROMANIAN AGRICULTURAL MANAGEMENT

Monica Mihaela TUDOR

Romanian Academy – Institute of Agricultural Economics, Casa Academiei, Calea 13 Septembrie, 13, District 5, 050711, Bucharest, Romania, Phone/fax: +4021.318.24.11, Email:monik\_sena@yahoo.com

*Corresponding author:* monik\_sena@yahoo.com

### *Abstract*

*The main socio-economic tendencies of farm management in the Romanian agriculture in recent years reveal structural changes: rejuvenation of managerial body, acceleration of the transfer of land resource operation to younger managers; diminution of the consumption of labour force in the Romanian agriculture; increased productivity of labour involved in agricultural activities. Agricultural systems operate in a dynamic and complex environment, in a continuous change and subject to constant pressure generated by external shocks as economic and financial crisis, BSE crises, Foot and Mouth Disease and Bluetongue etc. 'Resilience' is a developing concept, which has been empowered to examine economic performance and responsiveness to exogenous shocks. In this context, the aim of this study is to examine the relationship between economic resilience and the changes in Romanian farm management under the impact of recent economic crises. The article concludes that the rejuvenation of farm management body is the adaptive answer of Romanian farm system to the current economic challenges.*

*Key words:* farm management, structural changes, economic resilience, Romania

### INTRODUCTION

Even since the '80s the research on the determining factors of the economic performance in the primary sector of the economy (agriculture) focused on the socio-professional characteristics specific to farm managers. The multiple case studies conducted on the human capital in agriculture proved that a high formal educational level leads to the increase of farmers' activity efficiency. Furthermore, it was found out that education entails higher performance gains for the farmers who are acting in environments subject to change and modernization compared to those coming from a static traditional context [6]. Most studies conducted so far relate the different inefficiency levels of farm managers to their access to information and to their managerial skills [1]. Taking these arguments into consideration, we shall focus our study on the body of managers from the Romanian agriculture, as the economic performance of this sector decisively depends on their skills and capacity to efficiently use the resources they manage.

In the modern era, characterized by greater economic dynamism, the private entrepreneurship is an important engine of economic growth and competitiveness [5], [7]. Rural enterprises, as well the farms, are currently experiencing times of change, exacerbated by the global interdependency and integrated economies [4]. As a result of the challenges, difficulties and rapid changes within the economy and society, the identification and strengthening of those skills required for solving, and overcoming those challenges turned increasingly important [10]. If economic resilience means identifying the ways and manners of solving the issues related to increasing the capacity of averting or recovering the negative effects of external shocks [2], it follows that entrepreneurship will in turn serve as basis of economic resilience [11].

The questions to which this study attempts to answer is whether this rejuvenation process has positive effects upon the economic performance of the farm system in Romania and under what conditions it should be encouraged? The second question is if rejuvenation of farm management represents a

resilient answer to the economic changes of Romanian agriculture?

## MATERIALS AND METHODS

To provide a comprehensive image of the managerial body from the Romanian agriculture, our paper correlates the socio-demographic characteristics of farmers (as human capital aspects of farm management) with the economic performance of the farm. The main demo-social dimensions of Romanian farm managers according to which the farm performance was analysed in the present paper are:

- *The structure by age of farm managers* provides significant signals with regard to the *potential innovating capacity* of the representatives of primary sector. A younger age structure is associated with greater willingness to accept innovation, to internalise new ideas of business management, new technical and technological procedures and to generate innovative ideas due to greater openness towards risk assumption [9]. The openness to innovation also stems from the fact that young people usually have higher educational capital compared to older people and their social independence permits them a much higher mobility.

- *Structure of farm managers by their agricultural training level* reflects their ability to access and use innovations with a high-tech level, new farm management tools, etc.

The conclusions of this article are based on

the analysis of secondary statistical information (national and Eurostat database statistics) on the quantitative and qualitative demo-educational characteristics of the farm managerial body, in order to capture their influences on the farm economic performances as reflection of their resilient capacity.

## RESULTS AND DISCUSSIONS

Today, Romania recorded the *highest number of farms* of all 27 EU countries (3.7 mil. holdings that represents 32% of total EU-27 holdings) and in term of the average size of farm, our country registered one of the smallest utilized agricultural area (UAA) per holding (3.6 ha), four times smaller than the European average (14.6 ha) [12].

In recent years we have noticed a rejuvenation process in the managerial body from Romania's farming sector, which is a similar process to that experienced in other EU New Member States (Poland, Czech Republic, Slovakia and Bulgaria). Thus, according to Eurostat data, in the period 2005-2010, in Romania, the share of farm managers aged less than 45 years increased from 17.4% to 23.1%, while in Poland, the EU country with the youngest agricultural managers, the increase was from 34.7% to 39.2% and in the Czech Republic from 27.2% to 32.4% (Figure 1)

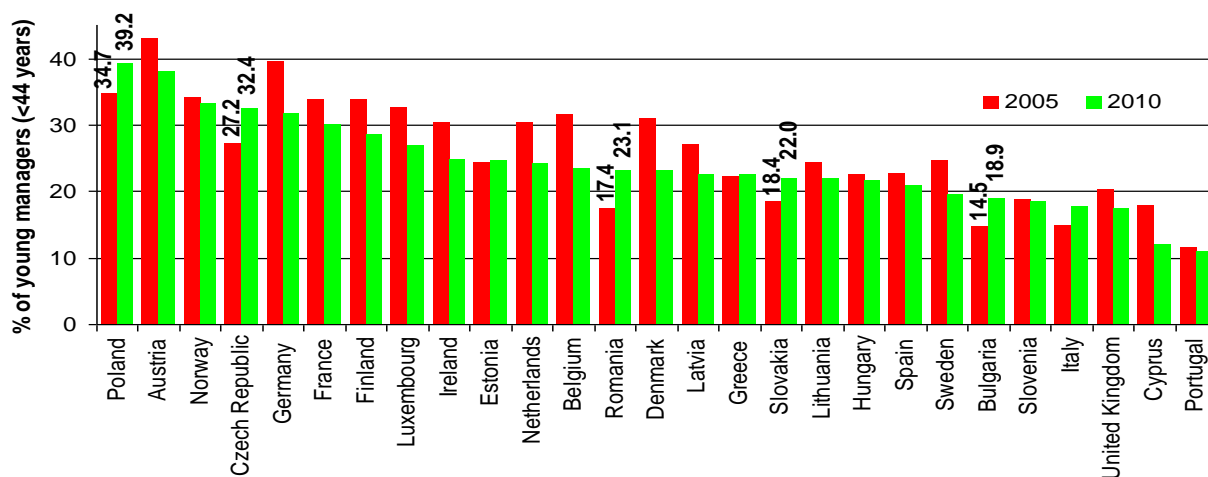

Fig. 1. Dynamics of agricultural managerial body by age in the EU countries  
 Source: Own calculations based on EUROSTAT data.



In the EU Old Member States, no rejuvenation process of the managerial body has taken place, and by comparison this can represent an asset for the EU New Member States as regards the openness to technological innovation in agriculture and to the economic performance increase in the primary sector.

The age structure of managers in the Romanian agriculture corresponds to a “reversed pyramid” (in conformity with the demographic language) in which the most weakly represented is the age group under 35 years old, while the elderly managers (aged 65 years and over) represent the group with the highest frequency (37.9%). While the greatest part of farms is administered by managers who exceeded the retirement age, the largest part of the utilized agricultural areas (50.3%) is managed equally by the two groups of managers who reached their active life maturity (aged from 45 to 54 and 55 to 65 years). Although the old managers (65 years or over) farm only 22.1% of UAA, in the year 2010 they had the largest number of livestock herds on their farms (27.3% of total LSU<sup>9</sup> at national level). High consumption of labour demanded by livestock animal raising activities, together with the conservatism in agricultural production practices<sup>10</sup>, that are specific to managers over 65 years old, make these use the greatest part of the annual work units (36.6%) in the entire Romanian agriculture.

The younger managers, under 55 years old, seem to have a larger opening to innovation in the management techniques of the farm

<sup>9</sup> The *livestock unit*, abbreviated as *LSU*, is a reference unit which facilitates the aggregation of livestock from various species and age as per convention, via the use of specific coefficients established initially on the basis of the nutritional or feed requirement of each type of animal (see table below for an overview of the most commonly used coefficients). The reference unit used for the calculation of livestock units (=1 *LSU*) is the grazing equivalent of one adult dairy cow producing 3000 kg of milk annually, without additional concentrated feed

<sup>10</sup> Conservatism – use of old agricultural techniques and technologies, which imply a higher labour input; weak opening towards technical and technological innovation

activity. A proof in this respect is the fact that these have an increased interest in the maximization of the economic effects of the agricultural work, the contribution of farms with managers under 55 years to the consumption of annual work units<sup>11</sup> being smaller than their percentage share in the agricultural land area or livestock herds.

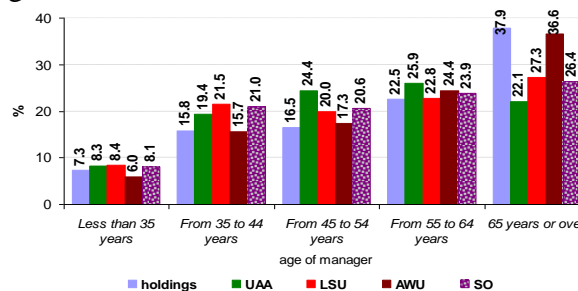

Fig. 2. Structure of the Romanian farms by managers' age in the year 2010 – main economic characteristics  
Source: Own calculation.

The contribution to the total value of the standard output<sup>12</sup> (SO) of farms grouped by managers' age directly depends on the production structure adopted at farm level, on the manager's experience or attitude in relation to change. Thus, the higher integration of crop production with animal husbandry generates higher incomes on the farm level than the sale of crop production. Based on the higher value-added obtained by using the crop products in animal feeding, the farms run by managers aged 35–44 years have a bigger contribution to the creation of the national standard output for agricultural sector (21%) than the percent of lands which they

<sup>11</sup> One *annual work unit*, abbreviated as *AWU*, corresponds to the work performed by one person who is occupied on an agricultural holding on a full-time basis. Full-time means the minimum hours required by the relevant national provisions governing contracts of employment. If the national provisions do not indicate the number of hours, then 1800 hours are taken to be the minimum annual working hours: equivalent to 225 working days of eight hours each

<sup>12</sup> The *standard output* of an agricultural product (crop or livestock), abbreviated as *SO*, is the average monetary value of the agricultural output at farm-gate price, in euro per hectare or per head of livestock. There is a regional SO coefficient for each product, as an average value over a reference period (5 years). The sum of the entire SO per hectare of crop and per head of livestock on a farm is a measure of its overall economic size, expressed in euro

manage (15.8%). A weaker development of the livestock sector in the case of farms managed by persons aged 45–65 years results in a lower contribution to the creation of standard output than the UAA share of these farms.

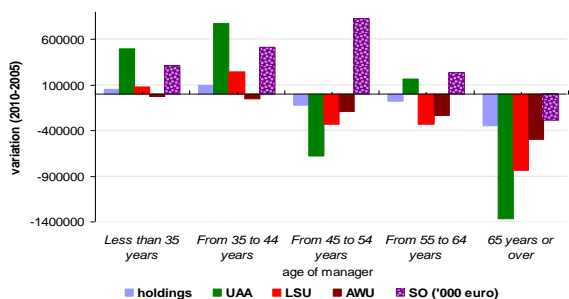

Fig. 3. Variation of the main socio-economic characteristics depending on the managers' age (2010 compared to 2005)

Source: Own determination.

In Romania, in the period 2005-2010, was manifested the tendency of rejuvenation of the managerial body in agriculture. It is worth mentioning the increase in the number of farms managed by young people under 35 years of age (by 54220 in absolute figures, which represents a 24% increase compared to 2005), as well as of those managed by persons in the age category 35–44 years old (by 95900 farms, equivalent of a 19% increase in the investigated period), accompanied by a transfer of the land areas from older managers to young managers (Fig. 3). It seems that after Romania's accession to the EU, there is an increased interest of the young people in agriculture, which began to be perceived as an attractive business with a significant growth potential. This is also proved by the successful implementation of Rural Development Measure 112 for setting up young farmers, for which over 22000 funding applications were submitted, and the European funds dedicated to it were fully contracted before the first half of the year 2013. With younger farm managers, we can hope for an improvement of the farm practices and a bigger opening towards technological innovation which together will bring about an increase in the competitiveness of the Romanian agricultural sector. At the other extreme, of elderly managers (over 65 years old), in the period 2005/2010 we could notice a diminution in their number and importance

in the operation of agricultural areas, which was largely due to the life annuity scheme application to the land owners over 62 years old who gave up working their land areas by themselves and transferred land use or ownership to other farmers. The application of this scheme was possible in the period 2005-2009 (after this year, as it was considered state aid, it was no longer allowed by the EU legislation); this resulted in the transfer of 329620 ha UAA [3] from the old farmers (that is 7.7% of the area owned by them in 2005) to other farms, leading to the adjustment of the farm structure both by ages and by the size of utilized agricultural area.

In the same period (2005-2010) we can notice an increased tendency of decoupling the animal production from crop production in the managers over 45 years old, who owned the greatest part of the livestock herds. The causes of the decrease in importance of the livestock sector in Romania's agriculture are multiple, on one hand stemming from the absence or diminution of the financial support to livestock production through Common Agricultural Policy or national support schemes, the severe sanitary-veterinary restrictions (i.e. those applied in the case of products of animal origin, milk, etc.), the restrictions to the exports to EU imposed, for instance, by the swine fever. However, the domestic livestock production is far from covering the national consumption needs and the self-sufficiency level from domestic resources decreases with the diminution of livestock herds. As a result, the domestic supply of animal products is deficient (in the year 2010, for instance, Romania's imports of live animals and products of animal origin totalled 984 million euro, the trade balance at this chapter being negative: -551 million euro [8]). This uncovered market niche could represent a strong incentive for the medium-sized farms to get oriented towards livestock production. However, the younger managers do not increase the number of animals at the same rate at which the farms run by old farmers give up animal raising. In Romania this contradictory trend would probably continue, with negative effects upon the total value of agricultural production.



Fig 4. Romanian farm managers' agricultural training level (a) by age categories and (b) on total, 2005-2010  
Source: Own calculations based on EUROSTAT data.

According to the last Agricultural Census, in 2010 most managers in Romania's agriculture have only practical experience<sup>13</sup>.

Only 2.5% graduated an agricultural school (generally *basic agricultural training*). The new young managers (under 35 years and between 35 and 44 years), who got involved in agricultural business in the period 2005-2010, unfortunately are not among those who attended an agricultural training.

Furthermore, out of the managers aged over 45 years, who exited from the farming activity in the period 2005 – 2010, more than one-fourth had agricultural education. These two processes resulted in the decrease of the educational level of the body of managers from Romanian agriculture. In 2010 the share of managers who have only practical experience reached 97.5%, compared to 92.6% in the year 2005.

On the farms managed by persons without

specialized agricultural training (97.5% of total farms in 2010), 72.4% of Romania's UAA is farmed, these utilizing 93% of the agricultural labour force and contributing by 78% to the standard output. Almost in their entirety (95%), these farms can be classified as being subsistence or semi-subsistence farms because the standard output value per holding obtained from their agricultural activity amounts to under 8000 euro (Fig. 5).

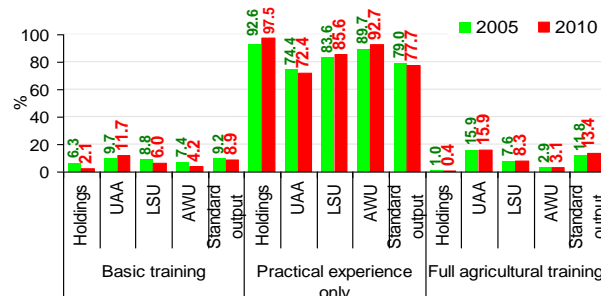

Fig. 5. Structure of agricultural farms by economic size and manager's training level  
Source: Own calculation.

<sup>13</sup> Agricultural training level:

- *practical experience only*: experience acquired through practical work on an agricultural holding
- *basic agricultural training*: any training courses completed at a general agricultural college and/or an institution specialized in certain subjects (including horticulture, viticulture, silviculture, pisciculture, veterinary science, agricultural technology and associated subjects); a completed agricultural apprenticeship is regarded as basic training
- *full agricultural training*: any training course continuing for the equivalent of at least two years full-time training after the end of compulsory education and completed at an agricultural college, university or other institute of higher education in agriculture, horticulture, viticulture, silviculture, pisciculture, veterinary science, agricultural technology and associated subjects

At the other extreme, the managers with *full agricultural training* represent only 0.4% of the number of farms, but they farm 15.9% from UAA, utilize only 3.1% of the labour force and contribute by 13.4% to the national standard output creation. Out of them, one in five administers farms for which the annual value of the standard output exceeds 50000 euro. Generally, the managers with vocational specialized training manage farms with larger land areas (about 20% of Romania's UAA), with production structures specialized in crops, an intensive utilization of the labour force and strong commercial orientation. Younger farmers (under 45 years old) show

higher levels than the Romanian average for the following characteristics: 26% more in terms of standard output per holding, 20% more hectares of UAA and 30% more LSU/holding. Likewise, their labour productivity in terms of economic output per full-time equivalent worker is higher than the average, as is the number of hectares managed per AWU.

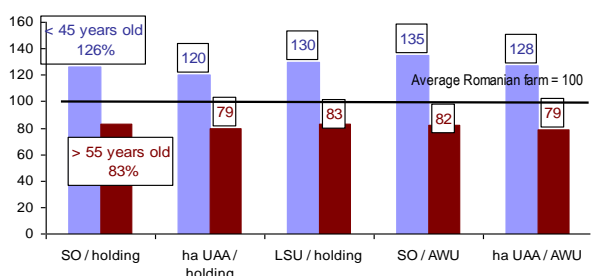

Fig. 6. Performance of young and elderly managers in Romania, 2010

Source: Own calculation.

Farmers older than 55 years perform below the average for all indicators: 17% fewer in standard output value, 21% fewer hectares of UAA and 17% less in LSU per holding. They produce less economic output and manage fewer hectares per full-time equivalent worker than the average, with values significantly below those of young farmers.

## CONCLUSIONS

Generally speaking, the *young farmers perform better than the older ones*, and the farm economic performance, evaluated in terms of labour productivity and land resources, is greater as far as the farm managers' agricultural training level increases. It seems that, *in Romania, younger farmers show a greater ability to adapt to change and to cope with the economic crisis*. This could be interpreted through the fact that the farm system's adaptive response to current economic environment challenges is represented by the management body rejuvenation. To increase the economic resilience of Romanian agriculture, it is necessary to encourage the managers' rejuvenation tendency supported by active measures to improve their specialized training

and access to finance.

## ACKNOWLEDGEMENTS

This work was supported by the project "Excellence academic routes in the doctoral and postdoctoral research – READ" co-funded from the European Social Fund through the Development of Human Resources Operational Programme 2007-2013, contract no. POSDRU/159/1.5/S/137926.

## REFERENCES

- [1]Ali, M., Byerlee, D., 1991, Economic efficiency of small farmers in a changing world: A survey of recent evidence. *Journal of International Development*, 3(1),1-27
- [2]Briguglio, L., Cordina, G., Tarrugia, N., Vella, S., 2008, Economic Vulnerability and Resilience. Concepts and Measurements, UN University WIDER World Institute for Development Ec. and Research May
- [3]Ghib, M.-L., Luca, L., 2011, Cum putem resuscita Renta viageră – ca o măsură compatibilă cu Politică Agricolă Comună, Bucharest, CRPE
- [4]Hudson, R., 2010, Resilient regions in an uncertain world: Wishful thinking or practical reality. *Cambridge Journal of Regions, Economy and Society* 3(1): 11–25
- [5]Lafuente, E., Driga, O., 2007, 1st Report on Entrepreneurial Activities in Romania. Centre for Entrepreneurship & Business Research, CEBR working paper series, WP 01/2007
- [6]Lockheed, M. E., Jamison, T., Lau, L. J., 1980, Farmer education and farm efficiency: A survey. *Economic development and cultural change*, 37-76.
- [7]Naude, W., 2008, Entrepreneurship in Economic Development, Research paper no. 20/2008. United Nations University: UNU-WIDER
- [8]Steriu, V., Otiman P.I. (coord.), 2013, Cadrul național strategic pentru dezvoltarea durabilă a sectorului agroalimentar și a spațiului rural în perioada 2014-2020-2030. Romanian Academy, Bucharest
- [9]Jung, T., Ejeremo, O., 2014, Demographic patterns and trends in patenting: Gender, age, and education of inventors. *Technological Forecasting and Social Change* 86, 110-124
- [10]Zaman, Gh., Vasile, V., 2014, Conceptual framework of economic resilience and vulnerability at national and regional levels, *Romanian Journal of Economics*, Institute of National Economy, vol. 39(2(48)), 5-18
- [11]Williams, N., Vorley, T., Ketikidis, P., 2013, Economic resilience and entrepreneurship: A case study of the Thessaloniki City Region. *Local Economy*, 28(4), 399-415
- [12]\*\*\* EUROSTAT database



## COMPETITIVENESS AND PROFITABILITY OF SUDANESE GUM ARABIC IN NORTH KORDOFAN STATE

Ghada A. M. YASSEEN, Adil Y. ELJACK, Mohhamed E. D. AHMED,  
Aladdin E. HAMAD

University of Dalanj, Dalanj, Sudan, Phone: +249634837022, Mobile: +249912123553, Emails: gadayasseen@yahoo.com, adelneel@yahoo.co.uk, drmoh70@yahoo.com, draladdin.1992@hotmail.com

**Corresponding author:** gadayasseen@yahoo.com

### Abstract

*Sudan is the world's largest producer of gum Arabic. Which is a natural forest product; produced from Acacia senegal and Acacia seyal trees. Sudan is considered as a key supplier of raw gum Arabic in the world as it used to provide more than 80% of high quality gum Arabic in the world market. The product is used primarily in the food industry but has medicinal and technical uses as well. This study investigates the main reasons behind the fluctuation in Sudanese gum Arabic export, as well as specifying the main importers of Sudan's gum Arabic during (2000-2013). In addition the study investigates the competitiveness of the Sudanese gum Arabic in the world market during (2000-2013). Data were collected from different sources that relevant to the field of the study. The analysis was done using descriptive statistic and Policy Analysis Matrix (PAM). The findings of the study have shown that the major reasons behind the decline and fluctuations of the Sudanese gum Arabic the increase in the production cost. Furthermore, exporting gum Arabic is financially and economically profitable. Also Sudan has high competitive ability to export gum Arabic. The study also refers to the negative impact of taxes on gum Arabic. The study recommended that: the government should design a specific policy through reducing the taxes and fees for gum Arabic export in order to increase its comparative advantage.*

**Key words:** Sudan, gum Arabic, PAM

### INTRODUCTION

Sudan is a vast country located in north east Africa with an area of 1.9 million square kilometres. It is land stretches between latitudes  $23^{\circ} 8'$  and  $8^{\circ} 45'$  north and longitudes  $21^{\circ} 49'$  and  $38^{\circ} 34'$  east. The great length gives the Sudan a unique range of ecological systems, and extends along the maritime border on the Red Sea coast, and penned two Arab countries are (Egypt and Libya) and 5 African countries, (Fig 1.) show the Sudan location. This vast area of land covers a number of different ecological and climatic zones, from the desert in the north to the tropics in the south with the Nile crossing the country from south to north. Agriculture generally provides the livelihood for the great majority of the population.

Sudan is the world's largest producer of gum Arabic, which is one of the four important agricultural export commodities, along with livestock, cotton and sesame.



Fig 1. Sudan position on the map

Gum Arabic is "The dried exudation" produced from the trunk and branches of the genus Acacia; namely Acacia senegal and Acacia seyal locally known in Sudan as Hashab and Talha respectively [2] and [9].

The two acacias are found in Sub-Saharan Africa in a belt widely known as the gum belt. The gum belt refers to an area situated at latitude of between 12° and 16° north stretching across Sub-Saharan Africa [5]. In Sudan it stretches from the western border with Chad to the eastern border with Ethiopia (Fig 2.), it covers an area of about 500 thousand square km, and home to roughly one fifth of the population of Sudan.

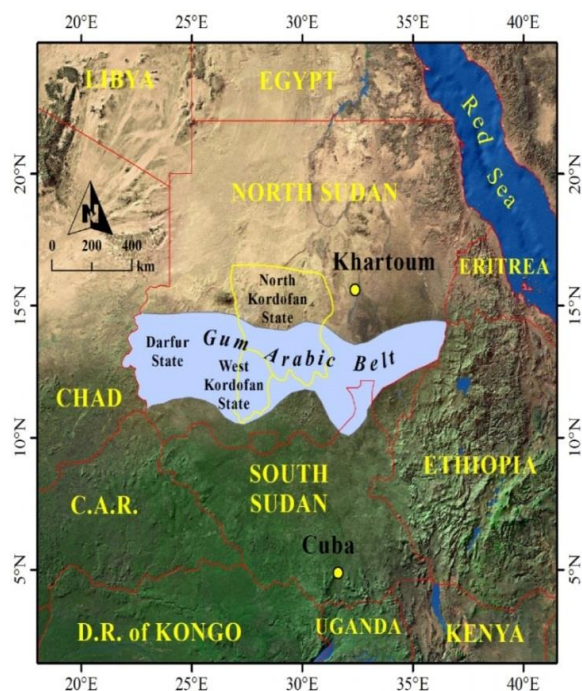

Fig 2. Gum Arabic belt in Sudan

Sudan gum Arabic total production and distribution have undergone changes between different producing areas, but it concentrated in North Kordofan State, in the central of Sudan and accommodates a big gum Arabic market in the world (Elobeid), which has been selected to the study (Fig 2.).

Sudan is considered as a major supplier of raw gum Arabic in the world as it used to provide more than 80% of high quality gum Arabic in the world market [3], [4] and [5], it is exports fluctuated due to unstable production and unstable policies of gum Arabic (Fig 4.).

As a result of the poor performance of the exports of this strategic commodity in the world market and the need for improving it in the future, the government of Sudan undertook positive steps towards deregulation of the gum Arabic company concession rights

in 2009 to provide incentives to producers to reactivate their production in favour of increased exports.

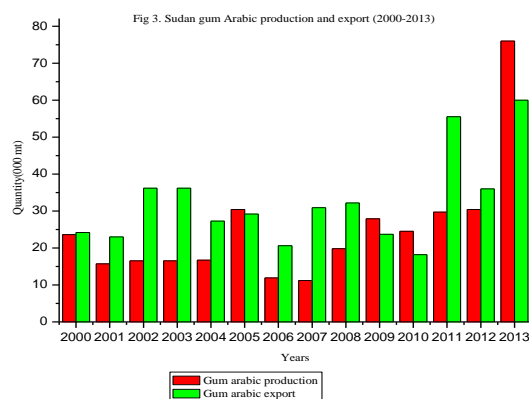

Fig.3.Sudan gum Arabic production and export (2000-2013)

Source:[1]

The government established the Gum Arabic Council for free gum Arabic trade in domestic and export markets. The recent switch in gum Arabic sector policy came as normal continuation of the 1992 liberalization policy of the economy of Sudan and the attempts of Sudan to access to the membership of the World Trade Organization (WTO). That policy is expected to rearrange Sudan gum Arabic production and trade based on its comparative advantage. The actual challenge that the Sudan will face is how to reduce the costs of gum Arabic production and increase its competitiveness in the world market.

## MATERIALS AND METHODS

This study aimed to measure the competitiveness, profitability and incentives of gum Arabic production in North Kordofan state, Sudan. It depended mainly on primary data, which was collected through questionnaire directly towards producers for the seasons 2010/11 – 2013/14 in North Kordofan State, while secondary data was obtained from official sources, covered the period (2000-2013). The data was analysed using policy analysis matrix (PAM), which designed to measure the divergence between actual market prices and efficiency prices. Efficiency prices are prices that have to exist if all markets perfectly competitive and the

economy in a state of general equilibrium.

The PAM is a tool for quantitative policy analysis developed by Monke and Pearson [6]. It is a product of two accounting identities; the first identity defines profitability as the difference between revenue and costs (rows), whereas the second measures the effects of divergences due to distorting policies and market failures - difference between observed parameters and parameters that would exist if the divergences were removed - (columns). In this way, the matrix allows us to compute the effects of a particular policy or the adoption of a new technology on income, costs and profits. The PAM depends on a simple accounting identity stated as follows:

$$\text{Profits} = \text{Revenues} - \text{Costs}$$

Profits are defined as the difference between total sales revenues and costs of production. Costs are defined in two columns as tradable inputs and domestic factors (essentially land, labour and capital). Tradable inputs are those available at the international market level, while those available domestically [6]. In the PAM, profitability is measured horizontally, across the columns of the matrix, as demonstrated in (Table 1), it shown in the right hand columns and found by the subtraction of costs, given in the two middle columns, from revenues, indicated in the left hand column.

Table 1. Policy Analysis Matrix

Item	Total Revenue	Total costs		Profit
		Tradable inputs	Domestic factors	
Private prices	A	B	C	D
Social prices	E	F	G	H
Effects of divergences	I	J	K	L

Source: [6]

The rows of the matrix respectively represent:

- Private profitability ( $D=A-B-C$ )
- Social profitability ( $H=E-F-G$ )

The columns respectively represent:

- Output transfers ( $I = A-E$ )
- Input transfers ( $J = B - F$ )
- Factor transfers ( $K = C - G$ )

Effects of divergences ( $L= D - H = I -J - K$ )

Revenues, costs (tradable and non-tradable inputs) and profits are calculated using two

sets of prices:

First row is the private prices; these are the prices which private agents actually face in the market.

The second row is the social prices, these prices are designed to measure the opportunity cost to the economy of using a resource or domestic factors. The social efficiency prices for domestic factors of production (land, labour and capital) are estimated also by application of the social opportunity cost principle. Because domestic factors are not tradable internationally and thus do not have world prices, their social opportunity costs are estimated through observations of rural factor markets. [7]

The third row of the matrix represent, effects of divergences, which estimate the difference between the private and social values of revenues, costs and profits, which can be explained by policy interventions.

Private, Economic Profitability, international value added (IVA) and Domestic Resources Cost (DRC) is represented as measures of competitiveness.

Private profitability (D): the term private refers to observed revenues and costs reflecting actual market prices received or paid by producer, merchants or processors in the agricultural system [6]. For the government, private profitability means the boarder value of the product, minus production and marketing costs, all taxes and subsidies are excluded in computing public profitability, as they are merely transfer payments, but in the producer it means farm gate price less the production cost [6]. The private profitability calculations show the competitiveness of the agricultural system, given current technologies, output values, input costs and policy transfers. If private profits are negative ( $D < 0$ ), it indicates that producers are losing and expected to stop production unless something changes to increase profits to at least a normal level ( $D=0$ ). Otherwise, positive private profits ( $D > 0$ ) are an indication of gaining return and should lead to future expansion in the production system [6].

The Economic or social Profitability (H): these estimation measures comparative

advantage or efficiency in the agricultural commodity system [6]. The economic profitability obtained is the economic value of the product, less production and marketing costs valued at shadow prices. Economic Profitability is computed as:  $H = E - F - G$ .

For each entry in the matrix measured vertically any divergence between the observed private price and the estimated social price for revenues, costs and profits, must be explained by the effects of policy or by the existence of market failure [6].

Profitability coefficient (PC): the ratio of private and social profits is  $PC = (A - B) / (E - F - G)$  or  $D/H$ , the PC measured the incentive effects of all policies and thus services as a proxy for the net policy transfer, since  $L = (D - H)$ . Its usefulness is restricted when private or social profits are negative, since the signs of both entries must be known to allow clear interpretation [6].

The net transfer caused by policy and market failures ( $L$  in the matrix) is the sum of the separate effects from the product and factor markets,  $L = (I - J - K) = D - H$ .

International Value Added (IVA): is a measure of absolute international competitiveness, measured as the value of revenue less costs of tradable inputs in US\$. A positive IVA implies a net foreign exchange earnings and the competitiveness of the product.

Domestic Resource Cost (DRC): measure the efficiency of domestic production relative to international markets. It indicates whether the use of domestic factor is socially profitable ( $DRC < 1$ ) or not ( $DRC > 1$ ). It is calculated as  $G / (E - F)$ . If  $DRC > 1$ , it means that the opportunity cost of using domestic resources exceeds the value added at social prices, and the product will not be internationally competitive. It is better in this case, to reallocate resources to an alternative product. The reverse hold for  $DRC < 1$  indicates that the economy saves foreign exchange from local production, because the opportunity cost of using domestic resources is less than the net foreign exchange it gains (in export) or saves (in substituting for imports).  $DRC < 1$  also indicates efficiency and international competitiveness.

The nominal and effective protection

coefficients (NPC and EPC) are the most popular measures of agricultural incentives.

Nominal Protection Coefficient (NPC) is a ratio of commodity revenue at market prices to its world value. This ratio indicates the impact of policy that causes a divergence between the two prices. In the PAM, is computed for output as  $NPCO = A/E$  and for tradable input as  $NPCR = B/F$ . Since the inputs cost in gum Arabic production is minimal, only NPCO is dealt with here considered as just NPC. If  $NPC > 1$ , it indicates that the private price of output is greater than its parity price, which means protection measures provide positive incentives to produce the commodity, If  $NPC < 1$ , it indicates that the product returns to the producers are less than the social returns that means the product implicitly taxed. When  $NPC = 1$ , it indicates a neutral situation (returns to producers are the same as returns from selling in a free market system using international prices). A basic defect of NPC is that, no accounts are taken for the subsidies and levies on imported inputs. EPC is an indicator of incentives, it measures the degree policy transfer from product market – output and tradable – input-policies, is the ratio of value added in private prices ( $A - B$ ) to value added in world prices ( $E - F$ ), or  $EPC = (A - B) / (E - F)$  [6]. EPC is used to correct the main defect of the nominal protection coefficient of neglecting taxes and subsidy elements on inputs. The EPC, however, takes the effect of taxes and subsidies on traded inputs only, while domestic inputs are excluded. If EPC value greater than one, at the existing exchange rate, means that government policies provide positive incentives to producers to produce the commodity, while EPC value less than one indicates that producers are not protected through policy interventions and taxed.  $EPC = 1$  implies either no intervention or the net impact of various distortions in both the input and product markets results in a neutral effect on value added.

## RESULTS AND DISCUSSIONS

Private and economic profitability, international value added and domestic



resources cost were used as measures of competitiveness.

Table 2 shows both private and social profitability, which were positive at farm level. These results indicated a relatively favorable farm gate pricing policies being encourage domestic production of gum Arabic.

From the results in the table, it is noted that in all seasons except 2011/12 private profitability is more than social profitability, this is an indication that gum Arabic production in North Kordofan State enjoys subsidy in form of a new technology or any facilities that will lead to an increase in production. From the results as the private profitability was less than social profitability in season 2011/12, clear that the gum Arabic has been taxed by the government, in form of direct fees or indirectly like deterioration of exchange rate.

Table 2. Private and social profitability of gum Arabic in North Kordofan state – Sudan

Season	Private profitability	Social profitability	Profitability coefficient
2010/11	251	79	3.177
2011/12	166	221.5	0.749
2012/13	940	433	0.749
2013/14	1047	823	1.272

Source: Own calculation

From (Table 3.), the positives values of International Value Added (IVA) per unit, for the period under consideration, indicated positive foreign exchange earnings and absolute competitiveness.

In relative terms, it is more competitive in seasons 2012/13 and 2013/14 than the other seasons.

This means that the opportunity cost of using domestic resources, measured at world prices or in foreign currency, is less than the value added generated by the product measured at world prices or in foreign currency.

DRC values less than one, which means the opportunity cost of using domestic resources less than value added at social prices, so the product will be internationally competitive, the decreasing trend in DRC values, indicate the increasing in competitiveness.

Table 3. IVA and DRC of gum Arabic in North Kordofan state – Sudan

Season	IVA (US\$/feddan)	DRC
2010/11	374	0.79
2011/12	631.5	0.65
2012/13	833	0.47
2013/14	1243	0.34

Source: Own calculation

Nominal Protection Coefficient (NPC) and Effective Protection Coefficient (EPC) are used to measures government intervention. From (Table 4.) NPC and EPC values greater than one except in season 2011/12, indicates positive intervention of the government in the gum Arabic production, and subsidized in form of new technology or any facilities can increase the incentives of producing it. But in season 2011/12, there is a negative intervention of the government in the product in form of different fees.

Table 4. Nominal Protection Coefficient and Effective Protection Coefficient

Season	NPC	EPC
2010/11	1.46	1.46
2011/12	0.92	0.91
2012/13	1.61	1.61
2013/14	1.20	1.20

Source: Own calculation

## CONCLUSIONS

In general gum Arabic production system in Sudan is profitable and competitiveness. Domestic Resources Cost for all seasons shows that gum Arabic is internationally competitive and progressing trend in competitiveness can be made by continue of devaluation. Reducing direct and indirect tax can increase the incentives of producing gum Arabic. Subsidize the product in form of technology or any facilities can increase the incentives of production.

## REFERENCES

- [1]Bank of Sudan, 2000-2013, various annual reports.
- [2]Food and Agriculture Organization, 1999, Production Yearbook, Vol. 53, Rome, Italy.
- [3]Food and Agriculture Organization, 2005, "Forest Resource Assessment, 2005" Rome Italy.
- [4]Larson, B. A., 1991, Natural Resource Prices, Export Policies and Deforestation: The Case of Sudan. World-Development, Vol. 19, No. 10: 1289-1297.
- [5]Macrae, J., Merlin, G., 2002, "The prospects and constraints of development of gum Arabic in Sub-

Saharan Africa". Washington, D.C., World Bank.

[6]Monke, Eric A., Pearson Scott R., 1989, The Policy Analysis Matrix for Agricultural Development, Cornell University Press Ithaca and London.

[7]Pearson Scott, Gotsch Carl, Bahri Sjaiful, May 2003, Applications of the Policy Analysis Matrix in Indonesian Agriculture.

[8]Yasseen, Ghada A. M. 2001, Constraints of Gum Arabic Production and Exports: A case study of North Kordofan State. M.Sc. Thesis, University of Khartoum, Sudan.

---

## MIGRATION FROM RURAL AREAS - ITS IMPACT AND PROSPECTS

---

**Silvia ZAHARCO**

The State Agrarian University of Moldova, 44 Mircesti, 2049, Chişinău, The Republic of Moldova, Phone: +373.22.432.387, Email: silviazaharco@mail.ru

*Corresponding author:* silviazaharco@mail.ru

### **Abstract**

*The present work is a study of migration phenomenon from national rural areas as well as of the social, demographic and economic effects caused by migration. There was analyzed the impact of migration on rural areas under general migration trends of the country and the peculiarities of the rural sector in the Republic of Moldova. Migration from rural areas is caused by lack of jobs, poor living standards, rising unemployment. Migration is an attractive opportunity, particularly for the rural population and remittances continue to be an essential support for the Moldovan economy. For these reasons, it is necessary to elaborate the ways to strengthen the development potential of migrants to their home country and to overcome the social consequences of migration.*

**Key words:** migration, remittances, rural area, rural population

### **INTRODUCTION**

The migration of rural population is one of the most complex demographic phenomena, which exerts a considerable influence on the economic and social development of rural areas, on population distribution and human resources, on the development of human habitat.

The share of rural population in Moldova is higher compared to other countries in this region, it constitutes 58.7%.

In rural areas there are recorded lower incomes, higher rates of poverty, low employment level and lower indicators of health and education, which has spurred much of the rural working population to seek a job abroad.

The high rate of migration strongly influences the economic activity in the Republic of Moldova, particularly in rural areas.

Taking into account that a significant part of migrants is interested in returning to their home, the Government should provide the migrants, who return home, with the necessary information and help them fit in the society. This is the first and the most essential step. The migrant also needs information regarding employment opportunities [4].

In this context, the aim of this article is to examine the impact of migration on the rural sector in the Republic of Moldova and to

highlight the ways to minimize the migration flows.

### **MATERIALS AND METHODS**

In order to characterize the evolution of the migration process in the Republic of Moldova there was taken into account the number of persons working or seeking work abroad by age groups, by area (urban, rural), by country of destination.

The data were collected from the National Bureau of Statistics. The period of the analysis of the study covered the years 2009-2013.

To analyze the migration process we used statistical method by providing data on the migration of population; socio-demographic method by researching issues related to migratory population diversity in economic and social development; economic approach by representing the number of migrant workers and how to reduce migration flows.

### **RESULTS AND DISCUSSIONS**

One of the main objectives of the state is to ensure full employment of labor force. In the Republic of Moldova the labor market faces a number of problems that require both short-term and long-term solutions. We can mention the following existing problems:

- Large share of employees in agriculture;
- Low labor costs;
- Population ageing;
- Long-term unemployment among young people;
- The reduction in the number of economically active population;
- Growing number of migrants.

The last element, related to population migration, has been and continues to be caused by the social and economic crisis in the country, as well as by the lack of well-structured state programs on employment policy and labor remuneration.

People continue going abroad to find a job, especially the people from rural areas (Table 1).

Table 1. The evolution of labor migration in the Republic of Moldova (thousand persons)

Specification	2009	2010	2011	2012	2013
Urban	89.5	90.6	92.7	90.2	94.4
Rural	205.4	220.5	224.2	238.1	238.0
Total per country	294.9	311.0	316.9	328.3	332.5

Source: National Bureau of Statistics, Labour Force Survey (without data from Transnistria).

According to statistics data and opinion polls, there is an increase in the number of migrants in 2013 compared to 2009 by 12.8%. The highest share belongs to the people from the rural areas in 2013 and account to 71.6% of total migrants. This number is constantly growing, increasing in 2013 compared to 2009 by 15.9%, while in urban areas this increase is not as significant, constituting only 5.5%.

The causes of increased migration in rural areas are: lack of employment opportunities to better paid jobs, low income, unemployment.

The failure of employment in the labor market in rural areas is dramatic. Compared to urban areas, villages lose their qualified potential due to migration. Also here it is recorded a significant difference between the sexes. Migrant women from villages are more prepared professionally, 25.7% of them have higher education and speciality, while among men only 12.2% have these characteristics. Annually, the number of highly educated women who go to work abroad is constantly

increasing. Among the rural migrant men, the highest share belongs to the men with vocational and secondary schools, 32.1% and 20.8% respectively.

Another aspect that deserves to be highlighted is that not the poorest people migrate. The decision to leave is often made for fear of becoming poor. In most cases, going abroad is related to an event that happens in the family and needs additional financial expenses that most people don't have: children's education, important family event, household expenses, real estate purchase, material support for young families [3].

Referring to official statistics, according to the last census (2014) we can see that 11.3% of the population is abroad. In the most cases the young population of the country is involved in the migration process. The most mobile are the age groups of 15-44 years. In rural areas, people of this age constitute more than 3/4 of the total number of rural migrants (Table 2).

Table 2. The distribution of rural labor migrants by age groups (thousand persons)

Specification	2009	2010	2011	2012	2013
15-24 years old	57.7	57.3	56.1	60.2	58.2
25-34 years old	57.0	70.5	74.3	78.2	79.8
35-44 years old	46.9	48.9	47.6	52.3	51.6
45-54 years old	38.0	37.3	38.6	40.3	39.4
55-64 years old	5.9	6.4	7.5	7.1	9.0
65 years old and over	0.1	-	-	0.1	0.2
Total	205.4	220.5	224.2	238.1	238.0

Source: National Bureau of Statistics, Labour Force Survey (without data from Transnistria).

The active involvement of young people in the migration process is obvious, moreover, there is a tendency to its increase. The intensity of the continuous migration of young people demonstrates the low efficiency of the policies pursued in the field of employment, especially for the youth.

The migration of the population of the Republic of Moldova is now quite diverse in form, types and trends. By the early 90s of the XXth century the emigration was predominantly oriented to the ex-USSR area.

Today, beside the East direction, the West direction took shape. The priority direction is represented by Russia, especially Moscow and St. Petersburg cities [1].

The distribution of migrants by destination countries reveals that most migrants work in Russia (68.1%). This happens because of the relatively low cost of travel, knowledge of Russian language, etc. For the most part, in this country people from rural areas work (77.4%), especially men.

In the European Union countries, where the access is difficult due to high cost and little knowledge of language, 25.5% of migrants work (Figure 1).

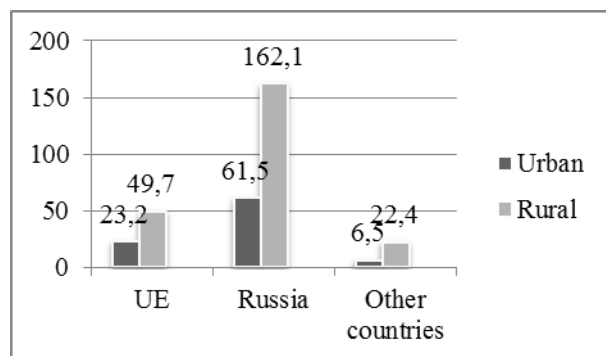

Fig.1. The distribution of migrants by destination countries and areas, thousand persons  
Source: National Bureau of Statistics (without data from Transnistria).

Among the EU countries the most popular destination is Italy, where 5.1% of migrants from urban area and 10.2% of rural area work.

Unlike the migrants in Russia, those working in the EU are older, have a higher level of education, and most of them had a job before going abroad.

Regardless of the medium, there is the feminization of migration flows by constantly increasing female migration. The women determine the host country according to their studies and professional training.

A negative aspect of the migration process is the increase of the number of children left without parental care, their parents working abroad. With a parent or both abroad for a longer period of time children may risk social, psychological, emotional deprivation. Official data show that approximately 170,000 children in Moldova have one or both parents

working abroad, mostly from rural areas. Today, the migrants who leave to work abroad are required to submit at the border crossing a document proving that they delegated guardianship over the child to somebody. However, most Moldovans go abroad in order to work illegally. In their case, this requirement can not be applied.

The children of migrants are the group the most predisposed to enter the second wave of migration, either through the processes of family integration or through the effects of habit and appearance of " the migrational culture ", when migration becomes a norm [2].

The factors that determine people to work abroad are mostly economic, represented by the lack of opportunities to obtain adequate income for life. The majority of migrants indicate as the main reason for going abroad low salaries in Moldova. The other reasons invoked are lack of jobs according to skills/qualification and bad working conditions (Figure 2).

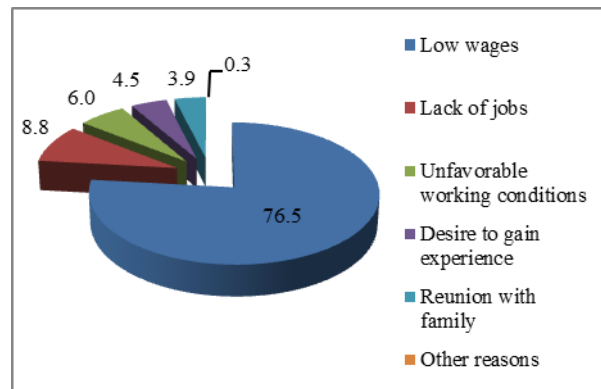

Fig. 2. Reasons for going abroad, %  
Source: National Bureau of Statistics

In general, in the Republic of Moldova, especially in rural areas, migration is determined mainly by push factors, such as poverty and lack of employment opportunities. Later, when the first migrants returned with stories about a better life elsewhere and family networks were created, pull factors began to play their role. However, poor economic situation in the country remains the dominant factor that keeps the migrants away from home. It is also true that about 15% of migrants do not plan to return

home (in rural areas), but intend to move to live in urban areas.

The migration of the population from rural areas strengthens the negative impact of migration on the demographic processes from rural areas by its indirect consequences: ageing of the population, decreased birth, skilled workforce reduction etc.

At the same time, returning migrants encounter various difficulties, such as:

- The domestic labor market has limited capacity to absorb returning migrants;
- The domestic labor market does not provide sufficient employment opportunities for young people;
- Migrants do not invest in the economy due to unfavorable business environment etc.

Because of the substantial difference between wages in the country and abroad, the motivation to migrate will not diminish. Migration continues to be an attractive opportunity. For these reasons, the efforts to consolidate the development potential of migrants for their country of origin and overcoming social consequences of migration are imperative. It is necessary to form among people the education of a migrational culture, the awareness of risks and the importance of making personal contribution to social, medical etc. funds to ensure their future.

In terms of the decrease of migration expansion it is necessary to implement a strategic policy capable of regulating and creating jobs with optimal wages.

The implementation of a social policy to support unemployed young people, who are looking for a job, would be another important step in reducing migration process.

The level of information and its accessibility among the rural population is significantly reduced, that's why it would be appropriate to implement some social programs to improve people's access to services, especially health and education .

The low level of the minimum wage relative to inflation rate requires redesigning the remuneration system and the inflation adjustment to public accessibility.

## CONCLUSIONS

The migration from the rural areas is increasing, being generated by the lack of jobs, low living standards, rising unemployment, economic changes in the distribution of productive forces.

The total number of migrants from rural areas of the Republic of Moldova cannot be determined exactly, but the fact is that it is steadily growing.

The results of the migration flow over general population ratio are strong and have long lasting effects. The negative aspects of migration are related to creating such problems as: family destruction, the low level of education of children, unbalanced relationships between family members.

Migration also has some positive aspects, such as helping to increase household incomes, rising living standards, lower unemployment. Finally, the cooperation and integration of migrants in different cultures gives them the opportunity to form new values and beliefs, and besides remittance migrants may send home new methods, projects, ideas and techniques acquired by working abroad.

## REFERENCES

- [1] Matei, C., Paladi, Gh., Sainsus, V., Gagauz, O., 2009, The Green Book of the population of the Republic of Moldova. „Nova-Imprim” Publishing House, Chişinău, Chap. 3, 13-18
- [2] Paladi, Gh., Gagauz, O., Buciuceanu-Vrabie, M., Penina, O., 2013, Rural area under the incidence of demographic changes. Akademos no. 3/2013, ASM Publishing House, Chişinău, 57-66
- [3] Postolachi, V., Poalelungi, O., Moşneaga, V., Gonţa, V., 2007, The Republic of Moldova – migrational problems. „CRIO” Publishing House, Chişinău, Chap. 2-5, 27-67
- [4] Vreşiş, M., Vladicescu, N., 2012, The social impact of emigration and rural-urban migration in Central and Eastern Europe. Executive Summary. [www.ec.europa.eu/social](http://www.ec.europa.eu/social), 1-3

## ASSERTIONS ON THE CHARACTER OF NASCENT MANAGERS AND ENGINEERS WITHIN THE PERSONALITY'S INVESTIGATION BY THE WELTANSCHAUUNG – EGO QUESTIONNAIRE

Iuliana ZAHARIA<sup>1</sup>, Elena COFAS<sup>1</sup>, Dana Maria CONSTANTIN (OPREA)<sup>2</sup>

<sup>1</sup>University of Agricultural Sciences and Veterinary Medicine of Bucharest, Faculty of Management, Economical Engineering in Agriculture and Rural Development, 59 Mărăști Blvd, District 1, 011464, Bucharest, Romania, Phone: +4021.318.25.64, Fax: +4021.318.25.67, Emails: iulia.zaharia@gmail.com, cofasela@yahoo.com

<sup>2</sup>University of Bucharest, Faculty of Geography, Meteorology – Hydrology Department, 1 Nicolae Balcescu Blvd, District 1, 010041, Romania, Phone: 004.0723389970, Email: danamartines@yahoo.com

**Corresponding author:** iulia.zaharia@gmail.com

### Abstract

*The research “Personality and Weltanschauung” is a complex topos which includes chapters like the present article and requires various and complementary investigative tools. This paper presents a statistical analysis and approach of some significant data regarding the axiological and self-control sub-system of the personality reflected in attitudes and traits of character - data served by the personality questionnaire Weltanschauung – Ego especially conceived for this research, described in a former article. The test sample included 100 matriculates of the Faculty of Management, Economical Engineering in Agriculture and Rural Development within the University of Agronomic Sciences and Veterinary Medicine of Bucharest (they are attending license studies within 2012 – 2016), aged 19-22, coming from both urban and rural areas and both genders almost in equable distribution. Among the character notes of this generation of students we recorded: prevalent (80%) is the extrovert, sociable, confident type, therefore with positive self-image, practical and pragmatic; the favourite leisure behaviour/ consuming is mainly passive rest, closely followed by the option for active rest; among the personal goods with key-role in self-control, the smartphone is by far the favourite; on top of the needs is the emotional need; with reference to aspirations and ideals, the prior direction for the investment of the resources goes to job, career, money, self-financing; the majority presents modest abstract-speculative spirit; 47% of subjects are mercantile.*

**Key words:** adolescent subjects (nascent managers and engineers), educational management, personality test, inter/trans-disciplinary questionnaire

### INTRODUCTION

This article presents partial results of the ongoing interdisciplinary research *Personality and Weltanschauung* (Psychology – Philosophy) to investigate the adolescents' personality [12] – the trait being *self-image*, focusing on the system of beliefs, values and symbols [1] [14], interpreted as an indicator for features, trends and potential of the ego. This part introduces significant data related to character as a subsystem of personality and their interpretation. The data were served by the questionnaire *Weltanschauung – Ego* (abbreviated questionnaire *WE*) which is an investigative tool designed specifically for this personality research [9], described and

justified in a previous article [15].

The motivation of the paper is rooted in the didactic process where we, the authors, are academics and researcher for more than ten years. The progress of knowledge, which partly resulted in remarkable technological progress, along with the ongoing social policies that generate mutations in the mindsets, attitudes and human behavior (as exogenous factors) and our own making based on life experience (as endogenous factor), determined us to increasingly concern about our students as typical subjects of the new generations. The aim of the research is both cognitive and ameliorative because knowing someone means to determine its cardinal character traits, attitudes and values – and this

knowledge is, in practical terms, an instrument for the behavior's prediction in various social situations and a potential gate if intervention is needed [5].

## MATERIALS AND METHODS

From the beginning we record fundamental considerations regarding the psychology of personality, which are the common substratum of the definitions, theories and approaches of this domain, in order to outline the theoretical framework to insert the study's results.

**Personality**, in psychological sense, is a theoretical construct which assumes the specific mode of organization of the psychophysical and psychosocial traits of a person. It is a bio-psycho-socio-historical and cultural synthesis, axiological and teleological oriented, which ensures the subject's original adaptation to the natural and social environs, with a functional core that mediate the development of the social behaviours which joins values–attitudes–ideals [10].

Personality incorporates the dynamic organization of the individual's cognitive, affective, volitional, physiological and morphological aspects, the content of self-awareness and the ego's image in another's consciousness (Sheldon & Allport cited by Țuțu) [13] – ensuring the continuity and the mental consistency in terms of individual history, functioning of fundamental mechanisms for original adaptation, as well as dynamic setting of the behaviours and conservation of its own structures.

If broadly personality consists of *all psychic phenomena*, narrowly it is *a set of psychological traits or characteristics (those constant aspects of the mental life)* [13]. Knowing the personality involves not only to reveal its traits (as parts), but also to identify linkages and relationships between them in order to integrate them into an indivisible ensemble (which is the personality).

Considering the structural-systemic point of view, *personality is a “dynamic, open, hyper-complex and probabilistic system”*, with dynamic structures that ensures consistency and integration for the *temper, skills and character*, i.e. the dynamic-energetic

component, the instrumental component, the relational component centred in values.

The **character** is that personality's subsystem reflected in the person's general psycho-moral profile, considered in the light of ethical norms and values, including the worldview based on socio – moral beliefs and feelings and the content and the purposes of activities which include aspirations and ideals. All these related components are integrated into a unified functional structure by mechanisms of selection and assessment. Briefly, the character is a system of *attitudes* and *traits* that determine one's relatively stable function and constant guidance to adapt to the external world and to his inner self.

**Attitude** is the internal specific position that a person has unto reality or unto a group of problems from it – position that allows to the individual to selectively orient himself and preferentially to self-regulate himself, as it brings together cognitive, affective and volitional *polarized* elements [10]; the harmonization and coordination of these elements prints pithiness and efficiency to the attitude. Defining for attitude is its permanent, implicit or explicit, relating to *values*, the attitude reflecting the recognition of values, their internalization by the individual and so the attitudes regulate the behaviour. When attitudes are consistent with social norms, they become values, forming what Linton called “*the attitudes – values system*” that *stands in the core of a person. The basic attitudes are: the attitude towards other human beings, the attitude towards the social system, the attitude towards profession, the attitude towards the own self.*

*Gaining stability, pithiness and significance, the attitudes become characteristic for the individual, turning into **character traits** which 1. are essential, defining, unique, unrepeatable and irreducible, differing from one individual to another, formed by the personal history of each individual; 2. they are stable, durable (which determines the behaviour's prediction); 3. they are consistent with the other; 4. they have ethic or moral value (they are not neutral). Character traits are systematized by twos in polar pairs (e.g. lazy-worker, unselfish-selfish, coward-brave,*



etc.), each person integrating the entire palette of pairs, but with different weights, mainly to the positive (positive character) or mainly to the negative (negative character); the mutual balancing of the polar features is considered to be an ambiguous character.

M. Golu, cited by Țuțu [13] distinguishes two types of character traits:

1. **global character traits** – they are: the character's *unit* (the constancy and identity of one's conduct, beyond the situational/accidental changes); the character's *expressiveness* (the predominant development of one or several features that give to the whole a specific note); the character's *originality* (the distinguishing mark of a person in relation to another: authenticity in the assimilation of values, their internal coherence, their moral force, their varying stages of development and integration); the character's *richness* (the diversity of one's relations regarding other, work, etc.); the character's *stability* (it is given by the attitudes and character traits that determine a constant behaviour); the character's *plasticity* (the reorganization of its elements to ensure accord with new social realities, development of character and self-adjustment depending on the circumstances); the character's *strength* or *integrity* (its resistance to negative influences and outside pressures, resistance to various temptations);

2. **particular character traits**, differentiated by mental components valued by the individual and involved in determining his attitude towards the object of reference: *cognitive* traits (reflexivity, objectivity, critical thinking and their opposites); *affective-motivational* traits (sentimentality, shyness, greed, avarice, commercialism and their opposites); *volitional* traits (courage, independence, perseverance, firmness, determination, consistency, selfcontrol and their opposites); *intersubjective* features (solicitude, cooperative spirit, the spirit of mutual aid, altruism and their opposites); *moral* traits (honesty, kindness, fairness, dignity, modesty and their opposites).

G. Allport ranks the individual character traits (which he calls "personal dispositions"):

1. *cardinal traits* – one or two, the "root of life", which dominate and control the all

others, with significance for the individual and they put their mark on every act of conduct;

2. *central traits*, circa 10-15, which can be easily recognized as they are characteristic and control everyday situations;

3. *secondary or peripheral traits*, in large number, less active, which express unessential aspects of the individual behaviour, with episodic existence, latent and sometimes even their owner denies them (cited by Țuțu) [13].

The **ego** is the central structure of the personality, its higher integrative level, the core which develops, aligns and adjusts attitudes, behaviours and activities that voluntarily and consciously relate the individual to its self and to the outside world.

The ego creates the sense of identity, continuity and unity of the own existence, it is the ultimate form of our consciousness. It includes cognitive, emotional-motivational and attitudinal elements organized in a coherent, stable although dynamic structure. Ego's main forms of manifestation are the *self-image* and the *self-awareness*, which are in a dialectical relationship of conditioning and mutual involvement. Within personality, the ego fulfils cognitive, axiological, motivational, mediation and regulation functions [6].

After the theoretical framework, we mention that the research method used for this study is questionnaire *WE* – a personality questionnaire which measures the axiological system through two scales: scale *W*, with 33 items, investigates the ego in symbolic expression and scale *E*, with 50 items, investigates the ego in the behavioural expression and serves to control, to complete the first one for the idiographic profile. We applied this tool on a group of 100 subjects and through the analysis of data we aim to observe in objective manner parts of their frame of reference, with primary focus on the optimization of the educational process.

## RESULTS AND DISCUSSIONS

General characteristics of the experimental group<sup>14</sup>:

<sup>14</sup> We record here the same "General characteristics of the experimental group" as in the paper *Analysis and*

- 100 subjects matriculates of the Faculty of Management, Economic Engineering in Agriculture and Rural Development USAMV B, who are attending license studies within 2012 – 2016 and who chose as facultative/ optional subjects Philosophy and History of Culture (both subjects are normed with syllabus, courses and seminars for one semester);

- the students interviewed are aged from 18 to 26 years: 18 years 2%, 19 years 42%, 20 years 33%; 21 years 17%; 22 years 5%; 26 years 1%;

- there are 44 male subjects, 56 female subjects;

- 55 subjects are coming from urban areas, 45 from rural areas;

- religious influence in the family (directly or indirectly): atheism 1%; theism (dominant is the Orthodox Christian cult) 88%; atheist and theist mixed families 7%; other categories 4%;

- degree of exposure declared by the subject while filling in the questionnaire *WE*: “the responses represent me as usually” 66%; “the responses partially represent me; there are aspects I don’t want to disclose” 14%; “the responses reflect my actual disposal” 20%.

In this part of the paper we introduce the idiographic and nomothetic analysis for certain *lots of items* that measure character traits and characteristics of the attitudes-values system, outlining a partial profile of character for the generation of teenagers who are currently enrolled as students of the faculty.

The structure of this section: 1. synthetic investigation of certain premises related to significant life experience, temperament traits (openness) and skills; 2. characteristics of the attitudes-values system; 3. character traits: cognitive (reflexivity, objectivity, critical thinking) and affective-motivational (mercantilism).

**1.Synthetic investigation of certain premises related to significant life**

*Approach of Nascent Managers’ Worldviews within the Personality’s Investigation through the Weltanschauung – Ego Questionnaire* (q.v. I. Zaharia 2015) because it is the same lot of subjects

**experience, temperament traits (openness, self-confidence) and skills (pragmatism):**

**1.1.Significant life experiences:** through the lot with semi-open items we recorded 72% subjects who responded and exemplified, 4% subjects who selected “I do not have significant life experiences” and 24% subjects who selected “I don’t answer”. Table 1 enlists the centralized the answers of those 72% subjects who responded and exemplified, noting that one subject recorded *one or more* of the following experiences:

Table 1. Significant life experience

Significant life experience	No. of subjects
<b>Success achieved by work, deliberate effort and practice:</b> - passed exams: the educational process, high school bachelor, college admission, driving licenses (38 subjects) - jobs and volunteering (4 subjects) - sports, extreme sports (3 subjects) - music, dance, photography (3 subjects) - formative journey (3 subjects) - physical recovery (1 subject) - friendship (1 subject)	53
<b>Trauma, loss</b>	11
<b>Love</b>	7
<b>Family’s environment</b> (comfort or trauma)	3
<b>Freedom</b>	2
<b>Faith in God</b>	1
<b>Failure</b>	1

Source: Own determinations.

*The most formative experience is considered to be the own work completed successfully.*

The option of the 24% subjects who chose to abstain from exposure of significant experiences can be interpreted as introversion, vulnerability and/ or discretion, caution to self-disclosure; not to respond is a form of opponency. Regarding the subjects who believe that their first 20 years of life didn’t include significant experience(s), their answer can be interpreted as they have a value-threshold they didn’t achieved yet.

**1.2.Temperament traits and skills: openness, pragmatism, self-confidence**

*Prevalent (about 80%) is the extrovert, sociabil, confident type, therefore with positive self-image, also practical and pragmatic, with risk in the (self) analytical*

and (self) critical potential, potential which condition the development of the *inner space* as personal operating space and feedback of the ego; dominant practical intelligence related with social intelligence [3] [4].

Approximately 15% subjects are dominant introvert, partly emotional and intuitive (with intrapersonal communication exercise that enhances the inner space inside and opens the perspective of empathic understanding of others), more defensive and idealistic, possibly reserved on self-disclosure, potential risk at self-confidence and derived affirmation behaviours.

This category of subjects is found / was largely anticipated by the percentage of respondents who selected “I do not answer” to the items relating to significant life experiences.

Circa 5% of subjects chose to answer fully personal and the idiographic analysis of their responses indicates that they perceive themselves as balanced related to extraversion – introversion, they are more or less spontaneous and have developed both the practical operating capacity as well as the abstract level.

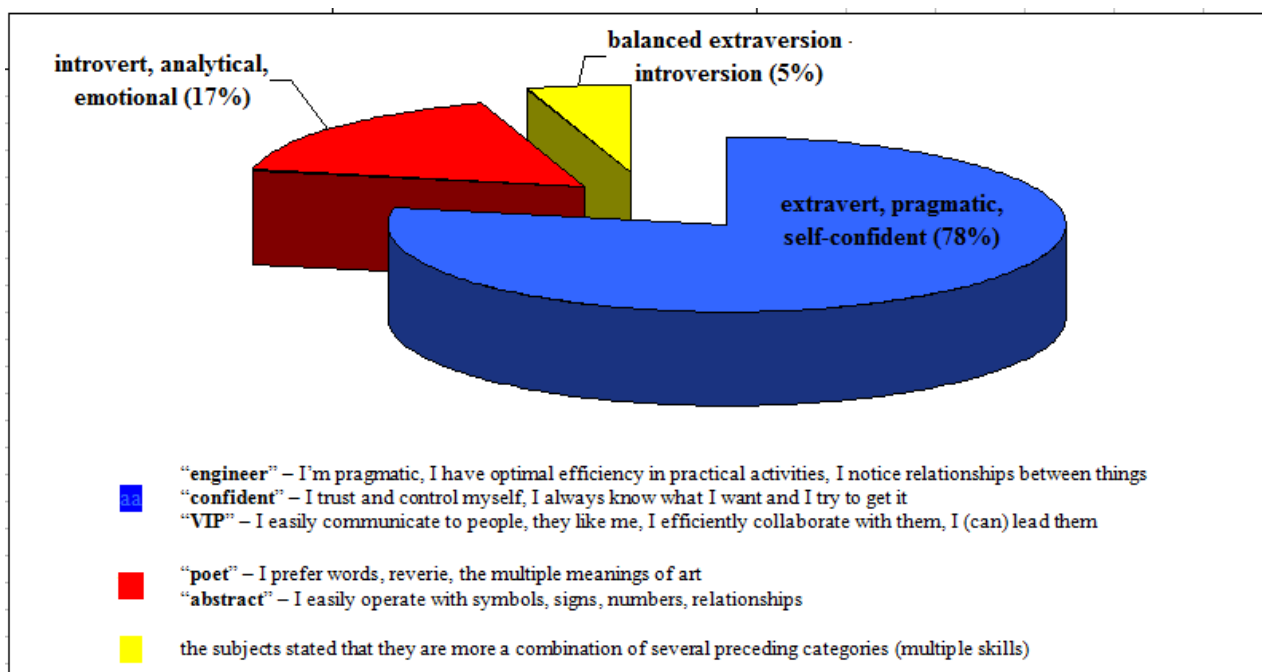

Fig. 1. Openness, pragmatism, self-confidence.  
 Source: Own determinations.

## 2. Characteristics of the attitudes-values system

**2.1. The significance of values “sacred” [2], “happiness”, “love” [4],** investigated by repertory grids (semi-open items) and the place of these values in the subjects’ axiological system are presented in Tables 2, 3 and 4.

Since this item belongs to the questionnaire WE/ scale W, its responses was checked/ correlated with the results of the other ontological items and on this basis we established that it predominates theists subjects (81%), but the concept/ the representation that they have about God is

discontinuous if related to Christianity and we did not even notice to comply with any other religious doctrines, except for about 15% of subjects whose idiographic ontological analysis reflects coherence and consistent representation of the Christian God.

The remaining 19% are dominant subjects adhering to materialism and relativism.

The concept of “happiness” has meanings that vary according to the characteristics of the subjects’ personality: for 31% of subjects the happiness translates into/ results from an assessment, confirmation coming from outside, indicating that happiness is conditioned by external positive feedback; for

27% of subjects happiness is synonymous with successful assertion of their ego, self-initiated or external challenges accepted, and it is conditioned by positive internal and external feed-back, unless the subject aims inner and undemonstrative transformation (the individual is in competition with himself) and then determinant is positive internal feed-back; for 21% of subjects happiness is to have satisfied the need of affection as external positive feedback (confirmation from the other); for 11% of subjects happiness is an internal dominant positive state, as a result of constant positive internal/ external feedback or efficient self-control; for 7% of subjects happiness lies in satisfying at least two of the previous needs (possibly all simultaneously): the need for external assessment, the need to assert, the need for affection – so it is conditioned by positive internal and/ or external feedback; 3% of subjects opposed to self-disclosure.

Table 2. Repertory grid for “God”

Meanings proposed by the item (“God” means...)	Subjects’ options
The creator, the preserver, the educator, the judge of the world	48%
More than I can think and express: perfection, omnipotence, absolute, eternity	33%
A (questionable) hypothesis for the genesis of the world, an ideal	7%
A human contrivance	4%
I do not know what to think, although I reflected and researched the topic	6%
I’m not interested in the subject, I do not know	2%

Source: Own determinations.

Table 3. Repertory grid for “happiness”

a) Meanings proposed by the item (I feel happiness when...)	Subjects’ options
when I count, whenever I am valued	31%
when I win (I reach important goals)	27%
when I feel loved	21%
usually, even without specific reasons	11%
seldom	2%
I do not answer	1%
Never	-
b) Answers fully personal: combination of the first three categories (twos or all three)	7%

Source: Own determinations.

In conclusion, *for more than half of the subjects, happiness is conditioned by exogenous factors.*

“Love” stands for 51% of subjects in inner experience and moral – rational acting; for 40% (39% + 1%) of subjects it is profound emotional experience, related to the sensorial level; for 8% of the subjects love means to bind together the rational, moral, emotional and sensorial dimensions of the self.

Table 4. Repertory grid for “love”

a) Meanings proposed by the item (“I love” means ...)	Subjects’ options
respect, commitment, responsibility	51%
deep emotion	39%
intense pleasure	1%
b) Answer fully personal: combination of the first three categories (twos or all three) 8% “gradual self-destruction” 1%	9%

Source: Own determinations.

## 2.2 Self-control

2.2.1. *Favourite leisure behaviour/ consuming:* they are energetic self-regulating behaviours to maintain the functional state.

Table 5. Favourite leisure behaviour/ consuming

Leisure behaviour/ consuming (denomination)	Subjects’ options
Passive rest (sleep and audio-visual: movies, news, entertainment)	46%
Active rest - Sports 14% - Artistic pursuits 9% - Shopping 9% - Housework 4% - Games with friends, socializing 3% - scientific pursuits 1%	40%
Active or passive rest dependent on context	14%

Source: Own determinations.

*Passive or passivating rest* has the main share (46%) in order to meet the need of rest possibly related to the subconscious need for “a bit anaesthesia” of consciousness, directly through sleep or indirectly through audio-visual consumption as evasion in a virtual dimension parallel with the passivation of the attitude and sensorial/ emotional overstimulation [8]. It follows the option for

*active rest* (40%) and 14% subjects who chose contextual active or passive rest (dependent on weather, environment, available time etc.).

2.2.2 *Valued personal things* [11], *involved in self-control*: we recorded 93% subjects that confirmed that they are inseparable from certain object(s) and exemplified, and 7% subjects who selected “I do not answer”.

Table 6. Personal objects (multifunctional and/ or with symbolical value and/ or sentimental value)

Objects	No. of subjects
mobile phone (smartphone)	80
needments (wallet / money / keys / documents)	27
computer/ internet/ TV/ mp3 player	19
car	10
Jewellery	7
cosmetic	6
clothes	5
photos	3
Books	3
glasses	1
Bicycle	1
House	1

Source: Own determinations.

The idiographic analysis and the subsequent nomothetic centralization of the responses indicate that 93% of subjects individually recorded *one or more* of the following, and the objects of their choices are interpreted as things that they are addicted to, in varying degrees.(Table 6).

2.2.3. *Key-value for self-control*: at the semi-open item “Whatever it is, I do not give up to...”, we recorded 94% respondents who answered by exemplification and 6% of subjects who selected “I do not answer” or left blank the item. The 94% of respondents individually recorded *one or more* as shown in Table 7.

Prioritizing the options, the percentage decreasingly recorded shows:

- the prevalence of emotional need for inter-bond, safety, self-affirmance and confirmation by maintaining a positive self-image in small group (family, other significant people, pets);
- the need to develop, maintain and promote the identity through beliefs and values embedded or not in an axiological system: theism or atheism, responsibility, respect, dignity, humanity, patriotism, freedom,

knowledge;

- the need for fun and comfort through consumer goods from the IT zone (smartphone, computer, television) or functional area (car);

- the need for vocational self-assertion (education, career, money).

Table 7. Priority value

Value (denomination)	No. of subjects
family	45
identity beliefs and values	33
fun and comfort	20
significant persons outside the family	16
vocational affirmance	10
Pet	1

Source: Own determinations.

In one way or another and to varying degrees from individual to individual, these data indicate addictions.

2.2.4 *Aspirations and ideals*: regarding the semi-open item “The meaning of my life is...” we recorded 51% fully personal answers, 28% answers “I do not know (yet)”, 21% answers “I do not answer” and no option for the response options “It doesn’t exist”, nor for “I am not interested in this topic”.

The 51% of respondents who answered individually recorded *one or more* of the following, and their answers are interpreted as acute needs of the development phase in which they lie, needs that generate the directions to invest the personal resources (table 8).

Table 8. Aspirations and ideals

Value (denomination) “The meaning of my life is ...”	No. of subjects
Social affirmance and confirmation (work, career, money, self-financing)	33
Knowledge, development	20
Family (starting a family and/ or protecting the present one)	17
Love, emotion	6
Transfinite	5
Primary needs	1
Pleasure	1
“Spending time”	1

Source: Own determinations.

To note the 28% of subjects who selected “I do not know (yet)”; they have not yet established a guideline value, which in part can be found in the peculiarities of

adolescence (unfinished personality system). In their case it would be interesting to study the type and the degree of motivation as motivation is correlated with the will and attention (factors responsible for resource mobilization and efficiency). We find again about 20% of subjects introverted or at least reluctant to exhibit their referential value vector.

Table 9. Cognitive traits: *reflexivity, objectivity, critical*

Item: "At the start / genesis of the cosmos stands ..."	
a) Meanings proposed by the item	Subjects' options
Matter shaped by different forces (e.g. particles, atoms, Big Bang)	22%
Idea (e.g. "Word, and the Word was God")	44%
I do not know what to think, although I reflected and researched the topic	18%
Energy in various forms	10%
I'm not interested in the subject, I do not know	5%
<b>b) Answer fully personal</b>	1%
Item: "The world, in its ensemble (inorganic, organic, biological) as substrate is ..."	
a) Meanings proposed by the item	Subjects' options
Matter	44%
Spirit, consciousness	36%
Energy	9%
I still do not know, although I reflected and researched the topic	9%
I'm not interested in the subject, I do not know	2%
<b>b) Answer fully personal</b>	-
Item: "Basically I am ..."	
a) Meanings proposed by the item	Subjects' options
Children of God, made by His icon and resemblance (36%) <i>or</i> I am my wholly feelings, emotions, thoughts (31%)	67%
a social animal, highly complex biologically and psychologically, creator and consumer of culture (18%) <i>or</i> a mind in a body (7%)	25%
a universe from a universes' network	2%
I still do not know, though I searched	2%
I'm not interested in the subject, I do not know	1%
<b>b) Answer fully personal</b>	3%
Item: "Who decides what is good and what is bad?"	
a) Meanings proposed by the item	Subjects' options
my conscience, my heart <i>or</i> God	38%
my reason, based on the context's specific/ social norms	36%
"God beyond us and the moral law within me"	20%
I do not know what to think, although I reflected and researched the topic	3%
I'm not interested in the subject, I do not know	1%
<b>b) Answer fully personal</b>	2%

Source: Own determinations.

### 3. Character traits

#### 3.1. Character cognitive traits: *reflexivity, objectivity, critical*

The nomothetic analysis of semi-open set of items – and of the traits behind – is complicated and uncertain; the idiographic analysis has greater validity, especially if it is controlled/ supplemented with results from the other test applied on subject.

We note, however, disparity by comparing the results/ item: initially materialistic or idealistic self-declared subjects seem to "reconvert" later, while answering to another item from this lot.

These differences translated into incoherence between "the original substance" and "the substances derived from the original substance" (a monistic materialism and idealism designates ontological principles irreducible to each other) can be interpreted as superficialism, logical inconsistency or at least inattention to record.

Correlating with the previous results, if a subject expressed antagonistic responses on same problem, it may involve low analytical and critical spirit, reduced availability to reflexivity, proclivity to irrational.

Also, a unilateral approach tends to focus the ego on the "inner world" (to "assimilate" the world into the own values) or to melt it into the "external world", depersonalising the individual – a balanced ego, in fact, is built by the equilibrated symbiosis of the two dimensions.

Table 10. Affective-motivational character traits: *mercantilism*

Item: "As for the money ..."	
a) Meanings proposed by the item	Subjects' options
better rich emigrated than poor in my country, I cannot be happy without money <i>or</i> rather rich, anywhere	47%
better poor in my country than rich emigrated	37%
<b>b) Answer fully personal</b>	16%

Source: Own determinations.

#### 3.2. Affective-motivational character traits: *mercantilism*

The responses to this item indicate that 47% of subjects require satisfaction of needs by

purchasing power and those needs are insufficiently fed, and their gratification conditions the individual's comfort with himself.

For 37% of respondents, the need for purchasing power is not a priority and it is not a sine qua non constraint of the ego's affirmance. Thus, almost 50% of the subjects are mercantile.

## CONCLUSIONS

By linking the data above, we recorded certain character notes of the generation of students currently enrolled as students of the faculty.

The most formative experience is esteemed to be the own work, efforts, completed successfully.

Regarding temperament traits and skills, prevalent (80%) is the extrovert, sociable, confident type, therefore with positive self-image, practical and pragmatic.

Among beliefs theism is prevalent (81%), but most of the subjects have a discontinuous Christian representation of God;

Regarding values, the concept of "happiness" was described by four categories of meanings which shows that for more than half of the subjects happiness is conditioned by exogenous factors; "love" means for 51% of subjects inner experience and moral – rational acting, for 40% of subjects it is a profound emotional experience related to the sensorial level and for 8% of the subjects love means to bind together the rational, moral, emotional and sensorial dimensions of the self.

Self-control: the favourite leisure behaviour/consuming is mainly *passive or passivating rest* (46% of subjects chose sleep and audiovisual consumption), followed by the option for *active rest* (40% of subjects chose sports, artistic or scientific pursuits, shopping, housekeeping, socialization) and a 14% of subjects set on contextual choice (active or passive rest depending on weather, environment, available time etc.).

Among the personal goods with key-role in self-control, the smartphone is by far the favourite.

In this stage of personality's development, we

recorded the prevalence of emotional needs for networking, affective security, self-affirmance and confirmation within family or other significant groups, seconded by the need to develop, maintain and promote the own beliefs and values embedded in an axiological system, and after that comes the need for fun and comfort through consumer goods (computers, television, car), and the last is the need for vocational self-assertion.

On medium and long term, with reference to aspirations and ideals, the declared three directions for the investment of the resources are:

1. job, career, money, self-financing;
2. personal development by knowledge;
3. starting a family.

There are a 28% of subjects who have not yet outlined a value guideline which prioritizes their resources.

Cognitive character traits: the majority presents modest abstract-speculative spirit; tendency to irrational, subjective.

Affective-motivational character traits: 47% of subjects are mercantile.

To complete and to test these results, we shall continue to analyse the data obtained by the other methods of personality's investigation applied to the same subjects: the Smiescheck questionnaire for pronounced tendencies [9], a test for mental flexibility and the projective test DAT [7].

## REFERENCES

- [1]Aerts, D., D'hooghe, B., Note N., 2005, Introduction: Worldviews, Science and Us, Global Perspectives, <http://www.vub.ac.be/clea/aerts/publications/2005introduction.pdf>
- [2]Cole, Graham, Do Christians have a Worldview? <http://www.theologynetwork.org/world-religions/getting-stuck-in/do-christians-have-a-worldview.htm>
- [3]Gardner, H., 2007, Inteligențe multiple. Noi orizonturi pentru teorie și practică, Editura Sigma
- [4]Goleman, D., 2001, Inteligența emoțională, Editura Curtea Veche, București
- [5]Georgescu, M., 2004, Introducere în consilierea psihologică, Editura Fundației România de Măine, București
- [6]Georgescu, M., 2009, Introducere în psihologia comunicării, Editura Fundației România de Măine, București
- [7]Georgescu, M., 2005, Vademecum în psihologie

proiectivă, editura Oscar Print, București

[8]Gheorghe, V., 2008, Efectele televiziunii asupra minții umane (ediția a II-a), Editura Prodomos

[9]Minulescu, M., 2004, Psihodiagnoza modernă. Chestionarele de personalitate, Editura Fundației România de Măine, București

[10]Popescu-Neveanu, P., 1978, Dicționar de psihologie, Editura Albatros, București

[11]Pretch, R.D., 2012, Cine sunt eu? o călătorie prin mintea ta, Editura Litera, București

[12]Sion, G., 2007, Psihologia vârstelor, Editura Fundației România de Măine, București

[13]Țuțu, M.C., 2008, Psihologia personalității, Editura Fundației România de Măine, București

[14]Vidal, C., 2012, Metaphilosophical Criteria for Worldview Comparison. *Metaphilosophy* 43 (3): 306–347.

<http://homepages.vub.ac.be/~clvidal/writings/Vidal-Metaphilosophical-Criteria.pdf>

[15]Zaharia, I., 2014, *Weltanschauung* – from Concept to a Rough Guide on Personality. *International Journal of Academic Research in Business and Social Sciences*, Vol.4, no.2, 434-442.