

PAPER • OPEN ACCESS

## Development of an Automatic Mini-Conveyor System for Product Monitoring

To cite this article: J. E. Bassey and K. C. Bala 2018 *IOP Conf. Ser.: Mater. Sci. Eng.* **413** 012021

View the [article online](#) for updates and enhancements.



**IOP | ebooks™**

Bringing you innovative digital publishing with leading voices to create your essential collection of books in STEM research.

Start exploring the collection - download the first chapter of every title for free.

# Development of an Automatic Mini-Conveyor System for Product Monitoring

J. E. Bassey\*, K. C. Bala

Department of Mechanical Engineering, School of Infrastructure, Process and Engineering Technology, Federal University of Technology, Minna. Nigeria  
Corresponding author email: [pajoebanet.jb@gmail.com](mailto:pajoebanet.jb@gmail.com)

**Abstract-** This thesis presents the development of an automatic mini-conveyor system for product monitoring. It is aimed at solving relative industrial and manufacturing problems such as product pilferage, inefficient supervision, monitoring and workmanship. It is also to improve production management system, using ICT based platform to enhance monitoring control and data acquisition (MCDA) system in manufacturing process. ASSEMBLY programming language was used on a programmable logic controller (Atmel 89C52) microcontroller for control and monitoring protocol. The method includes; simulation, hardware development; to include; sensing, counting and signalling wireless system containing sensors and a wireless radio frequency transmitter and receiver. Design calculation analysis, fabrication and operational tests were carried out on the developed mini-conveyor. The operational and test result shows that, the time the product travels along the conveyor through a distance of 0.8m between entrance and exit point sensors was between 15.7sec to 16.3sec. At a distance of 0.096metres between sensors, the response to display time on LCD is approximately 1.0 second. The developed mini-conveyor system is able to remotely monitor a product on a communication distance of 22 metres in which the required information is displayed on computer screen on a telnet hyper-terminal platform, through a baud rate of 1200. Therefore, the developed machine has open opportunities for product monitoring control and data acquisition in material handling systems in the industries for more accountability.

**Keywords:** Mini-conveyor, Automatic, LCD, Wireless system, Sensors, Industries

## 1. Introduction

Material handling is a field involving the transportation, storage, and control of goods and products throughout the processes of manufacturing, distribution, consumption and disposal of all related materials [1]. The focus of the material handling industry is on the methods, mechanical equipment, systems and related controls used to achieve necessary functions. The use of conveyors in material handling has been in practice since the early 20<sup>th</sup> century and is known to be the back bone of material handling [2]. Conveyors is commonly known as a piece of equipment that moves material from one place to another and are specifically for quick and efficient transportation of wide variety of materials of all shapes and sizes [3,4]. In a production system where, large quantities of products are produced with high production rates, the products are to be transported with material handling system that is sophisticated yet safe and reliable. According to [5], “material handling looks at the problems of moving, transporting, storing materials and product; improvement of handling methods”. Automated materials handling can be referred to as the management of material handling system by use of automated machineries and electronic equipments to reduce or eliminates the need for humans to do certain or all the activities in a material handling process manually. It also helps to increase the efficiency and speed by which materials or products are shipped, stored, and handled. This can significantly cut down on costs, human error or injury, and lost man hours [6, 7]. Wireless network may be referring to any type of computer network



that is connected without cables of any kind. Nevertheless, Wireless telecommunications networks are adopted and administered using a transmission system which is called radio waves [8].

This work explores the adoption of ASSEMBLY programming language instead of C++, JAVA, and FORTRAN on a Programmable Logic Controllers (PLC); Atmel 89C52 (AT89C52) microcontroller for control and monitoring protocol for the mini-conveyor. The system is developed on the back drop that in the future many production systems will need to adopt ICT in its operations with a choice to pick and adopt monitoring, control and data acquisition systems (MCADS) in the mist of diverse ICT base wireless production monitoring system that is effective, efficient and at low cost of implementation. A conveyor machine is developed on which products can be monitored during production run. There are several literatures concerning belt design with more focus on structural modification, maintenance efficiency, safety and some other research focuses on the automation area of maintenance, inspection and monitoring using different wireless sensor network (WSN) system and programmable logic controllers (PLC) structure and devices [13, 14]. There are many WSN system, PLC algorithm structural unit design and devices that are yet to be fully tested within a semi or full automated conveyor system as an alternative to the already implemented ones [20, 21]. The emphasis in recent time is on the application of ICT in manufacturing and industrial process to help improve production process and increase productivity.

## **2 Materials and Method**

### **2.1 Materials**

The materials used for this work includes:

Mild steel square pipes, angle iron, flat sheet, sprockets, chain and steel rollers. Other materials are PVC flexible (leather), electrical sensors, infra-ray (IR) transmitters, photodiodes, and quarter wave whip antennas.

### **2.2 Method**

In this project, consideration was made concerning the program language adopted and the basic essential electronic and electrical devices for the development of the wireless systems used. The conveyor is developed using essential mathematical engineering models, equations, design data from belt conveyor manuals and required material properties.

The development of this project involves the following methods;

1. Electrical-electronic circuit design for the automatic counting system.
2. Simulation of electrical-electronic circuit based on the assembly language as to evaluate its performance in real life and making necessary adjustment where necessary.
3. Hardware development
4. Design analysis
5. Fabrication
6. Testing

### **2.3 Design analysis**

The design analysis of the major components of the mini belt conveyor to achieve a functional structure as shown in Figure 1, were considered and hereby presented.

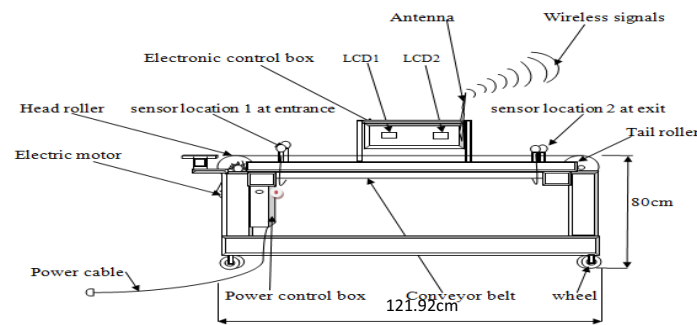

**Figure 1: Machine structure**

**2.3.1 Conveyor Belt Design**

The following are design parameters needed for conveyor machine development.

Belt capacity, C is obtained from equation (1).

$$C = 3.6 \times A_l \times V_b \times \rho_b \tag{1}$$

Where  $A_l$  = Load cross section perpendicular to belt;

$V_b$  = Belt speed;

$\rho_b$  = Density of conveyed material.

The belt width ( $W_b$ ) as given by [14] is:

$$W_b = \frac{T_l}{\sigma_b} \tag{2}$$

Where  $T_l$  = belt carrying side tension

$\sigma_b$  = (allowable design stress of belt material)

The belt thickness ( $t_b$ ) is as given from equation (3 and 4) by [13] as:

$$P_A = A_b \left( \bar{\sigma} - \frac{\rho_b \times V_b^2}{10^6} \right) \left( 1 - \frac{1}{e^{\mu \bar{\theta}}} \right) V_b \tag{3}$$

Where  $P_A$  = Absorbed power required by the system

$A_b$  = belt area

$\bar{\sigma}$  = Design stress for the belt material

$\rho_b$  = belt material density

$V_b$  = Belt speed;

$\theta$  = angle of contact

$\mu = 0.30$  (coefficient of friction for bare roller under dry condition) Fenner Dunlop conveyor manual, 2009.

$$A_b = W_b \times t_b \tag{4}$$

Where  $t_b$  = Belt thickness.

**2.3.2 Belt Friction and Tension**

The frictional and tension factors on the conveyor belt are obtained from effective tension ( $T_e$ ) from equation (4) as given by [13] are as follows:

$$T_e = F_{t\theta} + F_l + T_{LS} \tag{5}$$

Where  $F_e$  = total empty friction;  
 $F_l$  = load friction.

Similarly, the return side friction ( $F_r$ ) [14] is given as:

$$F_r = (F_e \times M_Q \times L_{cd} \times 0.4 \times g \times 10^{-3}) \text{ kN} \tag{6}$$

Where:  $F_e$  = 0.020 (for horizontal conveyor equipment friction factor)

$M_Q$  = Mass of moving parts per metre length

$L_{cd}$  = Centre to centre distance of rollers

$g$  = acceleration due to gravity

Therefore, total empty friction ( $F_{te}$ ) is:

$$F_{te} = (F_e \times (L_{cd} + t_f) \times M_Q \times (g \times 10^{-3})) \text{ kN} \tag{7}$$

Where  $F_e$  = 0.020 (for horizontal conveyor equipment friction factor)

$t_f$  = 45 (Fenner Dunlop conveyor manual, 2009)

Also the load friction ( $F_l$ ) is given as [14]:

$$F_l = (F_t (L_{cd} + t_f) \times \frac{C}{3.6V_b} \times (g \times 10^{-3})) \text{ kN} \tag{8}$$

Where  $F_t$  = 0.025 for horizontal and elevating conveyor

$C$  = Transport or capacity of the belt conveyor

Load slope tension ( $T_{LS}$ );

The slope tension is the product of the belt weight and the vertical lift and has its maximum value at the highest point (height) of the conveyor.

$T_{LS}$  can be calculated thus as [14]:

$$T_{LS} = \frac{CH}{3.6 \times V_b} (g \times 10^{-3}) \text{ kN} \tag{9}$$

The effective tension from equation (4) is:

$$T_e = F_{te} + F_l + T_{LS} \tag{10}$$

(The values of  $F_{te}$ ,  $F_l$  and are substituted to get the right relation for  $T_e$ )

Carrying side tension,  $T_1$

$$T_1 = T_e \left[ \frac{\xi}{e^{\mu\alpha} - 1} + 1 \right] \tag{11}$$

Where:

$\xi$  = 1.66 (Drive coefficient), [15]

$\mu$  = 0.30 (coefficient of friction for bare roller under dry condition) [15].

$\alpha$  = 180 = (angle of belt wrap or contact)

Return/slack side belt tension,  $T_2$

$$T_2 = T_1 - T_e \quad [13, 14] \tag{12}$$

### 2.3.3 Absorbed Power Required by the System

Power ( $P_A$ ) of the system is calculated from effective tension thus [15]:

$$P_A = T_e \times V_b \text{ (kW)} \tag{13}$$

Where  $V_b$  = Velocity of conveyor belt

Power requirement of the driving motor power ( $P_m$ ) is given by [16] as:

$$P_m = \frac{P_A}{\eta} \tag{14}$$

**2.3.4 Design of Chain Length**

The length (L) of chain for an open chain drive connecting two sprockets is obtained from the equation (11) [17] thus;

$$L = \frac{P}{2}(T_1 + T_2) + 2X + \frac{[\frac{P}{2} \text{Cosec}(\frac{180}{T_1}) - \frac{P}{2} \text{Cosec}(\frac{180}{T_2})]^2}{X}$$

15

Where P = Pitch

T<sub>1</sub> = Number of teeth on driving sprocket

T<sub>2</sub> = Number of teeth on driven sprocket

X = Centre to centre between sprocket

**3 Experimental Analysis on sensors**

**3.1 Analysis of Effect of Distance between Sensors on power Density between Sensors**

Sensors distance analysis is based on power transmitted and/or power density across sensors and magnitude of the incident current generated at the photodiode. The table 1 below shows the data obtained for the effect of distance between sensors on power density between sensors.

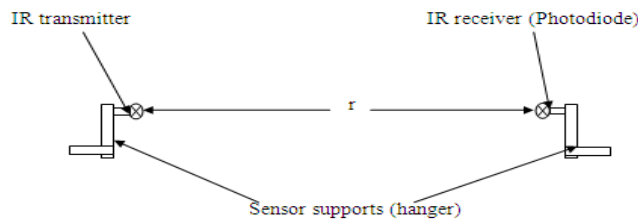

**Figure 2:** Distance between sensors

P<sub>t</sub> is the power transmitted by the IR sensor, which comes with the manufacturer specification. The data for P<sub>d</sub> is gotten from the formula;

$$P_d = \frac{P_t}{4\pi r^2}$$

[18] for charge carrying points 16

**3.2 Effect of Distance between Sensors on Response Display time on LCD**

Test was carried out to know the shortest time to display on LCD 2 as the product between the IR and photodiode sensor at the exit sensors point with reference to distance between the sensors, before signalling the data to the computer. Data obtained were tabulated and analyzed.

**4 Results and Discussion**

**4.1 Simulation of Designed Circuit**

Simulation was done on the ISIS professional animation platform, using a virtual circuit designed containing AT89C52 PLC microcontroller, on proteus 7.0 shown in figure 3 [19,20]. The components in the designed circuit layout are shown in figure 4.

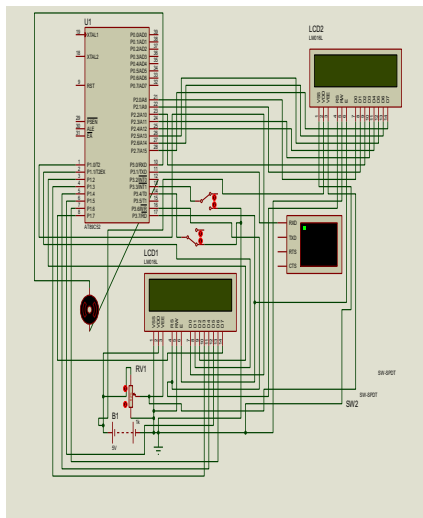

**Figure 3:** Circuit design on ISIS professional IR (Proteus 7.0 software)

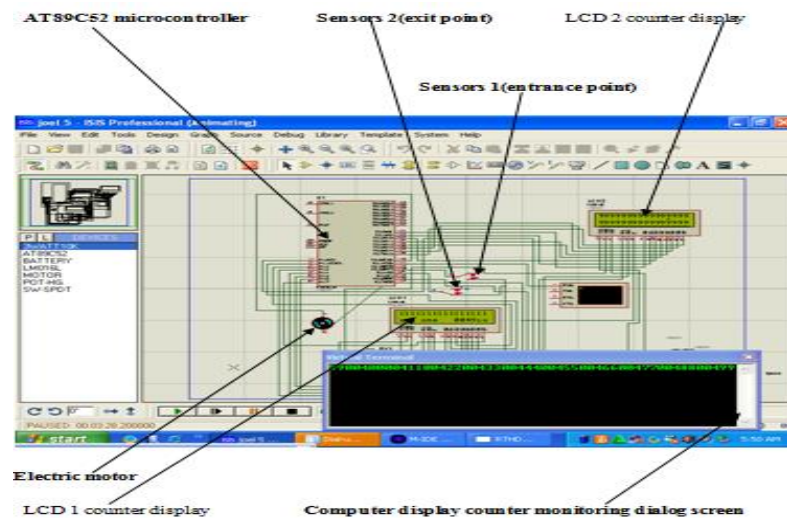

**Figure 4:** Simulation layout (Products through first sensors (entry) on conveyor-system counting)

**4.2 Design Results Used in the Development of the Mini-conveyor**

The table1 shows essential parameters obtained from design calculations and used for the development of the mini-conveyor.

**Table 1:** Essential parameters used in the development of the conveyor

S/N	ESSENTIAL DESIGN PARAMETERS	VALUES
1	Conveyor length ( $C_L$ )	1.2192
2	Belt length ( $L_b$ )	2.41m
3	Center to centre distance Between pulleys/rollers( $L_{cd}$ )	1.1252m
4	Belt width ( $W_b$ )	200mm
5	Belt thickness ( $t_b$ )	2.0mm
6	Pulley/roller Width ( $R_w$ )	230mm
7	Pulley/roller diameter ( $D_R$ )	50.8mm
8	chain length ( $L$ )	452mm
9	Belt mass ( $M_R$ )	1.64kg
10	Angle of contact or wrap ( $\alpha$ )	180degree
11	Mass of roller ( $M_R$ ) x 2	3.3kg
12	Motor power ( $P_m$ )	10Watts
13	Motor speed ( $N_i$ )	0.005m/s
14	Belt speed ( $V_b$ )	0.05m/s
15		379.4N
16		194.9N

17	Carrying side tension ( $T_1$ )	0.8m
18	Return side tension ( $T_2$ )	
	Conveyor height (H)	14
19	Driven sprocket number of teeth ( $N_2$ )	24
	Driving sprocket number of teeth ( $N_1$ )	

### 4.3 System Performance Results

Plate I and II shows the conveyor on off and on mode. Plate III shows product between sensors at the entrance point, at this point the product block the photodiode from the light emitted by the IR sensor, this blockage is seen as an interruption by the photodiode sensing system and it is transformed into counting sequence by the micro-controller and is reflected as a number on the LCD 1(yellow coloured).

Plate IV shows the object or product in between the sensors at the exit point. At this point also, the product blocks the photodiode from the light emitted by the IR sensor, this blockage is seen as an interruption by the photodiode sensing system and it is transformed into counting sequence by the micro-controller and is reflected as a number on the LCD 2 (blue coloured). At this point the second microcontroller compares the count between the two sensors, and sends the count data or count imbalance error data (inform of a code number 5) through the data transmitting wireless signalling unit to the MAX 232 interfacing wireless data receiver modem.



**Plate I:** conveyor after fabrication and finishing



**Plate II:** conveyor with counting electronic un with power on and Product on takeoff tray on conveyor



**Plate III:** Product between sensors at the entrance Point



**Plate IV:** Product between sensors at the exit point

The modem is connected to computer by means of a DB9 (COM 1 port) to USB conversion cable. The links that leads to the display of the monitoring dialog box on the telnet hyper terminal connectivity, on which the data received by the modem is displayed on the computer screen with window XP operating system, is as follows: Plate V shows the links and path taken to open the telnet hyper terminal







depending on the power in the motor from the power source. The distance between the entrance sensors and the exit sensor is 0.8m; it therefore means that the product is moving at the speed of 0.05m/s. This is the speed at which the conveyor belt is moving.

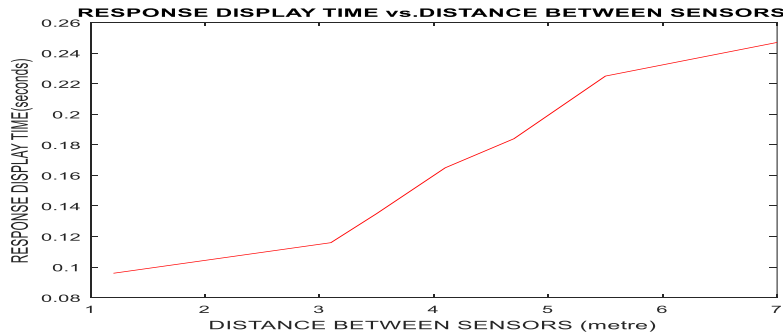

**Figure 7:** A graph of response display time vs. distance between sensors

**4.4.3 Test Distance**

During the test, the modem placed on the computer and connected to it was moved away from the conveyor machine and far away from the building in which the conveyor machine is stationed. The maximum distance at which there is no loss of connection signal was measured using tape. The distance measured is 22metres. This test reveals that, the wireless system developed will be operational at a maximum distance of at least 22metres between the factory location and the management or administration departments where the monitoring and collection of production data is carried out.

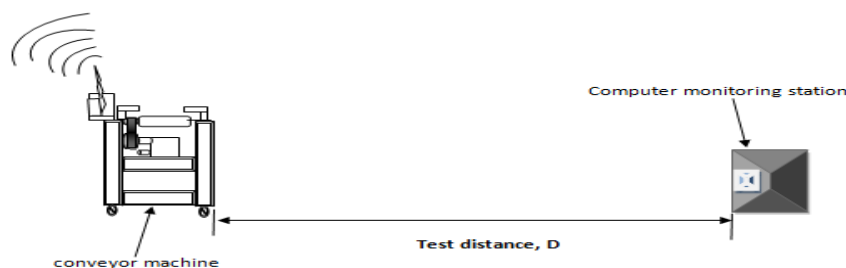

**Figure 8:** Distance between conveyor machine and the computer monitoring system

It was pointed out by [21], that SCADA was developed on an internet based protocols to enable monitoring and optimization of the process through the web system. However, the main objective of establishing an internet based system is to enhance rather than to replace computer based process control systems. Also, though SCADA and other systems shown in Table 4, are been used as solutions in controlling and managing processes in a wide range of industrial application. This X-system developed is a typical MCDA system and is more advantageous, because of the adoptability of an RFID module architectural structure with counter system in its wireless protocol design platform and is for a typical manufacturing based sector for monitoring, data acquisition and feedback, to reduced error in human intervention, theft reduction and elimination.

**4.5 Comparison of MCDA System and other Data Acquisition Systems**

The features of X-System developed with a typical MCDAS and other data acquisition systems are presented on Table 3.

**Table 3:** Comparison of X-System developed and a typical MCDA system and other data acquisition system

System Name	Embedded RFID and WSN software and hardware modification of	Web-based system	Low cost	Automatic monitoring compared	M2M wireless communication	communication range	standard time, target
SCADA	x	√	x	x	-	√	
ABACUS	x	√	x	x	-	x	
BARCO	x	x	x	x	15m	x	
MCDAS	√	√	√	√	50m to 200m	√	
X-SYSTEM	√	√	√	√	22m	√	

Table 4, shows a simplified comparison of few data acquisition systems renowned with the MCDA system developed. SCADA is widely known to provide monitoring and data acquisition system; it is mostly adopted in the gas and piping industry. BARCO, is known for supplying system monitoring to the industries especially for carpet manufacturing company, it uses the Bluetooth technology and has limited accessibility communication distance of about 15metres. The MCDA system is more flexible, robust and gives room to both software and hardware modification, lower cost, longer range of distance of communication and operates on a web base internet protocol using WSN system and embedded RFID than other known monitoring system. The communication distance tested for the wireless monitoring system developed X-system is 22metres. It is greater than the communication distance recorded for BARCO system. Although, the distance is less than that recorded for a typical MCDA system, it is still a typical MCDA system due to similarity in feature adaptation production line output monitoring system application in the industries.

## 5. Conclusion

This wireless-based monitoring control, data acquisition system, MCDAS, enable immediate update of the detail of production line activities as the production runs are being initiated from one production shift to another. For every production run, information is gathered, therefore, with this system there is no downtime in data reporting and transmission and this data can be printed at the end of every production shift. And also has data log, where previous data can still be assessed. It was also found from experimental analysis that the time it takes the product to move from the entrance sensor to the exit sensor covering a distance of 0.8m is between 15.7second to 16.3second. At a distance of 0.096metres between IR and photodiode sensors the response time to display on LCD is approximately 1.0 second. Therefore, showing that the belt round the rollers is running at a speed of 0.05m/s, which is the designed speed.

Therefore, with rapid advance in wireless information technologies, many solutions are emerging and its application in industries have been researched and developed. It can be concluded that this system which merges four technology that is; mini-conveyor, sensing and counting and signalling wireless network system into one solution is highly compatible and suitable to meet the requirement of any production line layout output monitoring system application in the manufacturing industries.

## References

- [1] Kay M. G., (2012). Material handling equipment. North Carolina State University. USA.

- [2] Conveyor Equipment Manufacturer Association (CEMA). Belt Conveyor Calculations. Retrieved from [http://www.kmg.agh.edu.pl/sites/default/files/pdf\\_BeltConveyorsCalculationsCEMA5\\_eng.pdf](http://www.kmg.agh.edu.pl/sites/default/files/pdf_BeltConveyorsCalculationsCEMA5_eng.pdf).
- [3] Austin Trusty. (2014). Choosing the right conveyor. Retrieved from <https://www.bastiansolutions.com/blog/index.php/2014/02/13/choosing-the-right-conveyors-for-your-system/#.V-AHOFsrJdg.com>. On the 27th September 2016, by 2.00am
- [4] Sanket, P and Thakur, A. G. (2015). A review Paper on Redesign of Gravity Roller Conveyor System for Weight Reduction through Optimization. *International Journal of Scientific and Engineering Research*. Vol 6(2). ISSN 2229-5518. <http://www.ijser.org>
- [5] Abu, J. O. (2011). Manufacturing Engineering and Production Management. Markurdi, Benue State, Nigeria. Aboki Publishers. 223-228.
- [6] Wise Greek (2010). What is Automated Materials Handling? <http://www.wisegeek.com/what-is-automated-materialshandling.html>. Accessed: 14th April 2010.
- [7] Salawu, E. Y., Okokpujie, I. P., Afolalu, S. A., Ajayi, O. O., & Azeta, J. (2018). Investigation of production output for improvement. *International Journal of Mechanical and Production Engineering Research and Development*, 8(1), 915-922.
- [8] Madhav and Anagha (2012). Wireless Sensor Network: A Promising Approach for Distributed Sensing Tasks. *Excel Journal of Engineering Technology and Management Science*.
- [9] Swartz, R.A., Iyunch, J. P., Sweetman, R., Rolfes, R. and Zerbts, S. (2008). Structural Monitoring of Wind Turbine Using Wireless Sensor Networks. *Environment*, 6(3), 1-8.
- [10] Jiang, X., Dawson-Haggert, S., Dutta, P. and Culler, D. (2009). Design And Implementation of a High-fidelity ac Metering Network. International Conference on Information Processing in Sensor Networks, IPSN (09), *IEEE Computer Society*, Washington, DC, USA, 253-264.
- [11] Dijwaard, Kleumen, Havinga, Kheiboer and Bijl. (2011). Industry: Using Dynamic WSNs In Smart Logistics For Fruits And Pharmacy. *In Sense System*, 218-231.
- [12] Kanmani, M., Nivedha, J. and Sundar, G. (2014). Belt Conveyor Monitoring and Fault Detecting Using PLC And SCADA. *International Journal of Advanced Research in Electrical Electronics and Instrumentation Engineering, (IJAREEIE)*, 3(4), 234-248. Retrieved on October, 2016 from [www.ijareeie.com](http://www.ijareeie.com)
- [13] Kaushal, P. S., Priyanka S. (2014). Design of an Automated sorting of object rejection and counting machine. *International Journal of Emerging Trends in Engineering and Development*, 3(4), 252-264. Retrieved from [http://www.rpublication.com/ijeted/ijeted\\_index.htm](http://www.rpublication.com/ijeted/ijeted_index.htm), October 2016.
- [14] Okokpujie, K. O., Odusami, M., Okokpujie, I. P., & Abayomi-Alli, O. (2017). A Model for Automatic Control of Home Appliances using DTMF Technique. *International Journal of Scientific & Engineering Research*, 8(1), 266-272.
- [15] Deshmukh, P. M., Trikal, S. P., (2015). Design, Analysis and Failure of Actual Charging Belt Conveyor System Used in the Industry to Set the Optimum Results. *International Conference on Recent Trends in Engineering Science and Management*, 2377- 2382. Retrieved from <http://www.conferenceworld.in>. October, 2016
- [16] Fenner Dunlop conveyor hand book (2009). Retrieved from [http://www2.hcmuaf.edu.vn/data/dangnh/file/5\\_Fenner%20Dunlop\\_%202009\\_%20Conveyor%20Handbook.pdf](http://www2.hcmuaf.edu.vn/data/dangnh/file/5_Fenner%20Dunlop_%202009_%20Conveyor%20Handbook.pdf).
- [17] Ananth, K. N., Rakesh, V. and Visweswarao P. K. (2013). Design and Selecting the Proper Conveyor-Belt. *International Journal of Advanced Engineering Technology (IJAET)*. Vol. 5(2). 43-49.
- [18] Okokpujie, I. P., Okokpujie, K. O., Ajayi, O. O., Azeta, J., & Obinna, N. N. (2017). Design, Construction and Evaluation of a Cylinder Lawn Mower. *Journal of Engineering and Applied Sciences*, 1254-1260.
- [19] Khurmi, R.S., Gupta, J.K. (2012). Theory of Machines. Ram Nagar, New Delhi. S. Chand and Company Publishing Ltd.

- [20] Adediran, Y. A. (1997). Telecommunication Principles and System. Minna, Nigeria. Finom Associates Publisher.
- [21] Okokpujie, I. P., Okokpujie, K. O., Nwoke, O. N., & Azeta, J. (2018). Development of A 0.5 Kw Horizontal Axis Wind Turbine. *Journal of Engineering and Applied Sciences*, 13(8), 2202-2208.
- [22] John J. (2016) Proteus PCB Design and Simulation Software: Introduction. <http://www.circuitstoday.com/proteus-softwares-introduction>. Retrieved 16<sup>th</sup> February, 2017.