

EXPERIMENTAL DETERMINATION OF THE EFFECT OF ENGINE SPEED AND RUN TIME OF THE TIMING BELT GEOMETRY OF PEUGEOT 307

Y. Tanimu¹, A. B. Hassan² and B. Alkali², M. M. Muhammadu² and Clifford O. Ogheneme³.

¹Department of Mechanical Engineering, Federal Polytechnic, Bida, Niger State.

²Department of Mechanical Engineering, Federal University of Technology, Minna.

³Department of Mechatronics Engineering, Federal University of Technology, Minna.

⁴Department of Mechanical Engineering, Waziri Umaru Federal Polytechnic, Birnin Kebbi, Kebbi State.

*Corresponding Email: *tanson3006@yahoo.com*

ABSTRACT

The operation of the timing belt is very critical to the performance of an automobile engine and the behavioural function is largely unpredictable especially on a poor road pavement and poor maintenance services. During operation timing belt are subjected to excessive elongation and wear. These detonation properties contribute to the timing belt running life and quality. The failure of the timing belt for some engine especially 307 means that apart from replacing the time belt, some part of the engines can be damage that is bent valves. In this Paper, the effect of the engine speed, run times on the timing belt geometry were investigated. The results obtained shows that the Pitch and groove thickness of the belt were more affected than the width and the total height and also that the engine speed has a positive correlation with the Pitch while the groove thickness has a negative correlation with the engine speed and that means failure will occur from these factors.

Keywords: Timing belt, Engine speed, Run time, Pitch, Groove thickness

1.0 INTRODUCTION

The auto-industry is one of the important sector of any economy. From past two decades optimum vehicle design is a prime concern in front of automobile industry. The timing drive system of an automobile is one of the most important system of an engine. The function of a timing drive is to transfer the rotation of crankshaft to camshaft and fuel Injection Pump (FIP) and other connected accessories so as to achieve proper timing at valves and the timing for fuel injection. Timing drive consisting of timing belts, timing belt/chains and timing gear drives.(Aniket and mulik, 2016) . A timing belt is located on the front side of the vehicle's engine and behind the plastic cam belt covers. It is designed to reduce the friction as well as generate more horsepower in an engine. The belt helps to keep the engine in check, preventing the valves from reaching and hitting the pistons.

Older belt have trapezoid shaped teeth leading to high rates of tooth wear. Newer manufacturing techniques allow for curved teeth that are quieter and last longer. Aftermarket timing belts may be used to alter engine performance. Original equipment manufacturer (OEM) timing belts may stretch at high revolution per minute, retarding the cam and therefore the ignition. (Simmens, 2009). Stronger, aftermarket belts, will not stretch and timing was preserved (Goodyear, 2010). In terms of engine design, 'shortening the width of the timing belt reduces weight and friction' (Mitsubishi, 2005).

Timing belts are typically covered by metal or polymer timing belt covers which require removal for inspection or replacement. Engine manufacturers recommend replacement at specific intervals (Gates, 2010). The manufacturer may also recommend the replacement of other parts, such as the water pump,

when the timing belt is replaced because additional cost to replace the water pump is negligible compared to the cost of accessing the timing belt. Indicators that the timing chain may need to be replaced include rattling noise from the front of the engine. (Siegel, 2007).

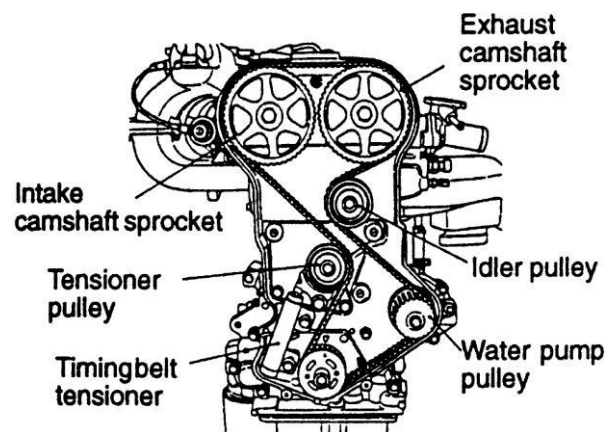

Figure 1: Engine timing system parts identification (www.autozone.com).

2.0 MATERIALS AND METHODS

2.1 Materials

Engine timing systems utilize the following components: idler or pulley, tensioner, hydraulic damper pivot arm and water pump as shown in Figure 2 below



Figure 2: Timing components (www.autozone.com)

2.2 Experimentation

The experimental setup comprises of a Peugeot 307 vehicle, a timing belt and a digital vernier calliper. It is desire to measure the timing belt wear as it run over a time period. Therefore, the table used to conduct the experiment were presented in the table 1. The Vanier calliper was used to record the geometric defects on the timing belts as it run over the time period, the speedometer on the dash board were used to record and set the engine speed of the at 1000rpm, 1500 rpm and 2000rpm for a period of four (4) hrs each. The images taken during the experimentation are presented in figure 3.

The timing belt used in this study has 140 teeth with a width of 24.76 mm and a pitch of 13.46 mm. Crank shaft pulley with 20 teeth drives two cam shaft pulleys with 40 teeth each through the timing belt.

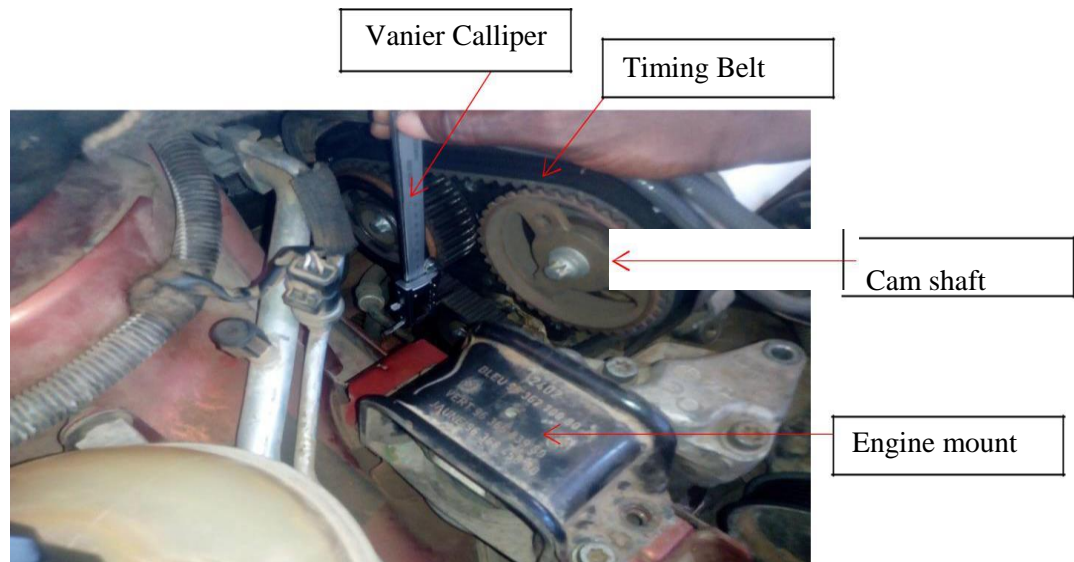

Figure 3: Image of experiment

2.3 Digital Vanier Calliper

The digital calliper used for measuring the variation in belt geometry is shown in Figure 4 below; it is portable and has up to four (4) decimal digits.



Figure 4: The Vanier Calliper.

3.0 Results and Discussion

The variation of the Timing belt Geometry obtained from the result of Experimental analysis was tabulated as shown in the table 1.

Table 1: Experimental results of analysis of timing belt geometry of Peugeot 307

ENGINE SPEED (RPM)	OPERATION TIME (Hrs)	PITCH (mm)	WIDTH (mm)	GROOVE THICK.(mm)	TOTAL HEIGHT (mm)
0	0	13.46	24.76	2.56	5.92
	0.5	13.475	24.76	2.480	5.92
	1	13.480	24.76	2.440	5.91
	2	13.488	24.76	2.390	5.91
	4	13.490	24.76	2.340	5.90
1000	0.5	13.477	24.76	2.475	5.90
	1	13.482	24.76	2.430	5.90
	2	13.492	24.76	2.370	5.90
	4	13.495	24.76	2.310	5.90
	1500	0.5	13.479	24.76	2.470
1		13.485	24.76	2.400	5.90
2		13.494	24.76	2.340	5.90
4		13.496	24.76	2.290	5.90

The graph of timing belt Pitch wear against run time was plotted as shown in Figure 5 below. (P = Pitch)

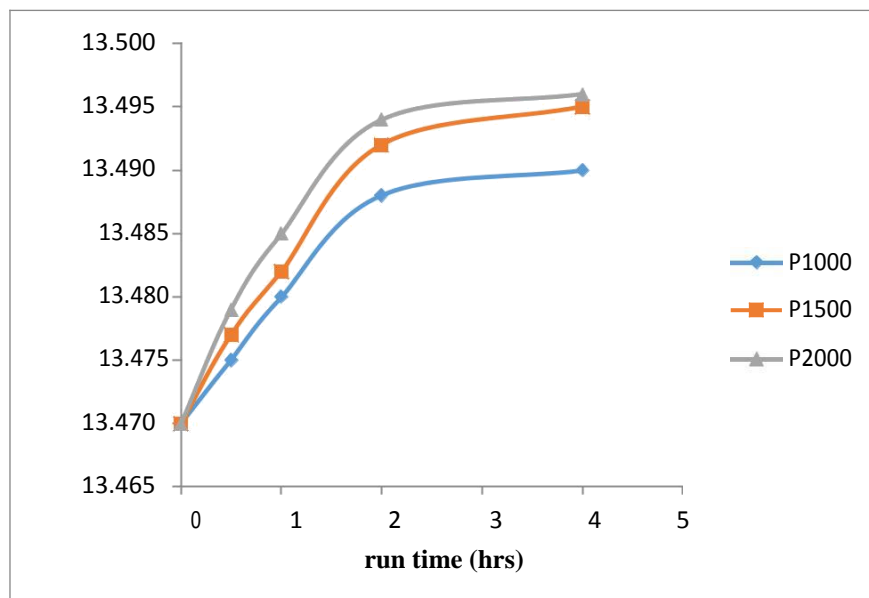

Figure 5: Effect of pitch against run time

The Figure 6 below represents the plotted graph showing the effect of belt Pitch against Engine speed.

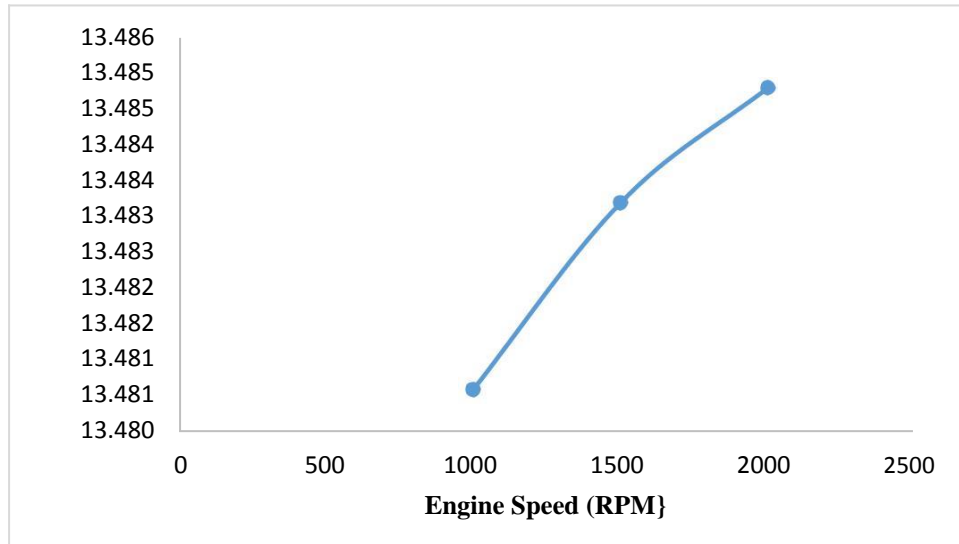

Figure 6: Effect of belt Pitch against Engine speed

The graph showing the relationship between belt groove thickness and run time was plotted as shown in figure 7 below. (T= Groove thickness)

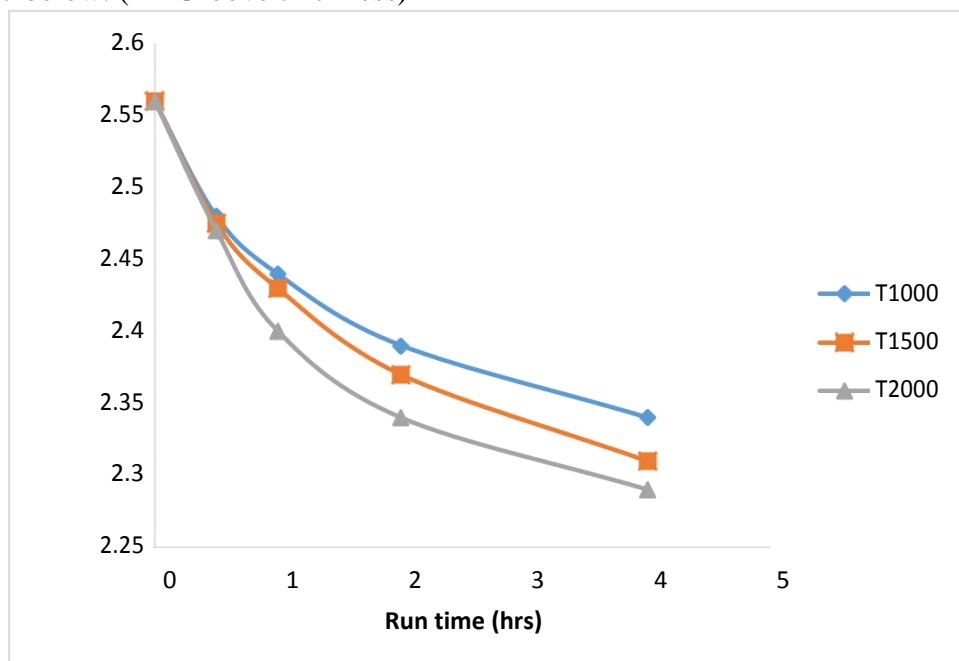

Figure 7: Effect of belt groove thickness against run time

The figure 8 below represents the plotted graph showing the effect of belt groove thickness against Engine speed

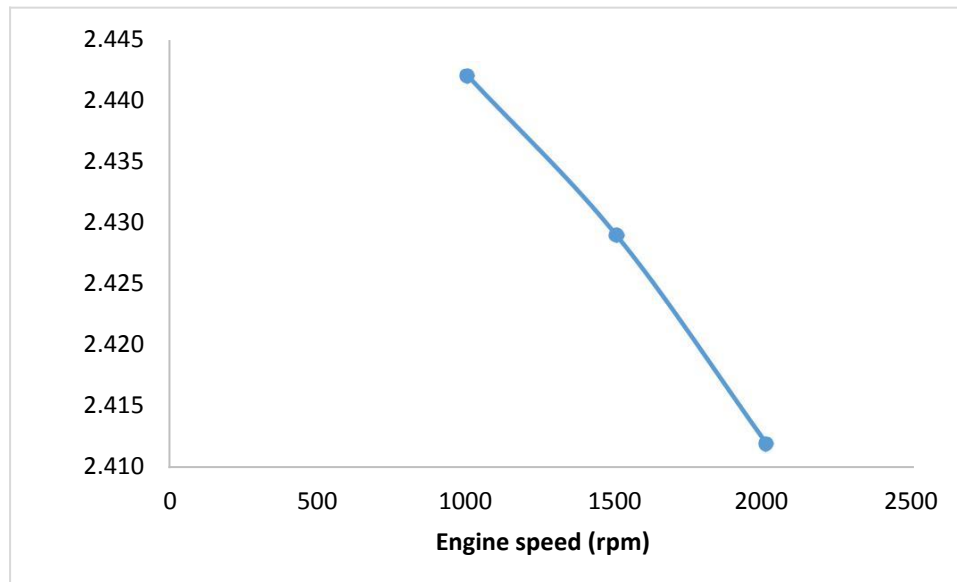

Figure 8: The effect of belt groove thickness against Engine speed

By monitoring the parameters in the period of working out, Figure 5 and 6 shows that the pitch and the thickness wear were more pronounced between 0-2 hours of operation after which they becomes approximately linear. It was also observed from Figure 7 that there is a linear relationship between the Engine speed and the belt pitch. Increase in speed will cause the pitch wear to increase accordingly, whereas from Figure 8 increasing the speed reduces the groove thickness.

4.0 Conclusions

The research studied the effects of run time and speed on the timing belt geometry. The result reveals that the run time and engine speed affects the belt pitch and the groove thickness, but the pitch is more affected than the belt width and the total height of the belt. Therefore all the common culprits of failure in timing belt analysis deeply focused on the variable effects performed under all the common culprits. Also with this paper it can be conclude that the lifetime dependency and influenced factors of timing belt drives will help us to provide guidance while occurring on those damages of belts and also the study of various effects on failure analysis steps of common study resulting on a decreasing performance that further lead to help for saving our money and valuable time of maintenance.

References

- Aniket, V., & Gujar, A. (2016). Literature review on simulation and analysis of timing belt of an automotive engine. *International journal of Engineering research and application*, Vol 6, Issue 8, (part 1) pp.17-21.
- Dolan, J. A. (1971). *Motor vehicle technology and practical work: parts 1 and 2*. Heinemann Educational Publishers.
- Gates. (2010, may 12). *Gates 2010 Timing belt installation manual*. Retrieved may 16, 2018, from www.autoserviceworld.com
- Goodyear. (2010). *Good year introduces Timing belt tools*. Retrieved from www.autoserviceworld.com
- Krumi, R. S., & Gupta, J. K. (2008). *A Textbook of Machine Design*. New Delhi: Euroshia.
- Norbye, J. p. (1984). Expanding on Excellence. *The 5-Series and 3-Series". BMW - Bavaria's Driving Machines*. Skokie, IL, USA: Publications International, p. 192. ISBN 0-517-42464-9.

The Nigerian Institute of Mechanical Engineers, Minna Chapter, 3rd National Conference.

- Ritch, O. (2014). *Small bore big pull*. Retrieved from <https://web.archive.org>
- Siegel, i. (2007, April 5). *Rattling noise could be from worn timing belt*. Retrieved from Chicago sun times: <https://web.archive.org>
- Simmons, K. (2009, February). *Timing to win ignition timing for maximum performance*. Retrieved from Circle track magazine: www.hotrod.com
- Steven H. (2012), *Safety Considerations in Optimal Automotive Vehicle Design*, A phd Thesis, The University of Michigan.
- Stojanovic, B., Ivanovic, L., & Blagojevic, M. (2011). Failure Analysis of the timing belt drives. *International Conference on Tribology in Serbian Tribology Society*, Vol. 21 pp.210-215.
- Stojanovic, B., Tanasijevic, N., & Miloradovic, N. (2009). Tribomechanical systems in Timing belt drives. *Journal of balkan tribological association*, Vol 15, No. 4 465-473.
- Temple, S. (2004). *Behold your timing belt: keeping the camshaft and crankshaft in sync*. Retrieved from Know how advance auto parts: <https://web.archive.org>
- Kost F. (2014). *Basic principles of vehicle dynamics*. In: Reif K. (eds) *Fundamentals of Automotive and Engine Technology*. Bosch Professional Automotive Information. Springer Vieweg, Wiesbaden. Retrieved from https://link.springer.com/chapter/10.1007%2F978-3-658-03972-1_10#citeas
-

