

# FOOD SECURITY IN NIGERIA: AGRICULTURAL DIVERSIFICATION AS A PANACEA

1st

## International Conference of Agriculture and Agricultural Technology {ICAAT 2019}

**VENUE:** Federal University of Technology, Minna  
School of Agriculture and Agricultural Technology

**DATE:** 23rd to 26th April, 2019



### EDITED BY

❖ Dr. C. E. Chinma  
❖ Mr. A. Ibrahim  
❖ Prof. J. N. Nmadu

❖ Prof. S. O. E. Sadiku  
❖ Prof. R. S. Olaleye  
❖ Prof. A. S. Gana  
❖ Dr. M. A. Ojo

❖ Prof. A. Aremu  
❖ Dr. A. J. Jirgi  
❖ Dr. S. O. Olayimika  
❖ Dr. B. A. Alimi



ICAAT 2019

©School Agriculture and Agricultural Technology  
Federal University of Technology, Minna, Nigeria.

All rights reserved. This proceeding or any portion thereof may not be reproduced or used in any manner whatsoever without the express written permission of the publisher except for the use for non-commercial purposes



**DEAN**

Prof. A. J. Odofin

**HEADS OF DEPARTMENTS**

Dr. A. J. Jirgi	Agricultural Economics and Farm Management
Dr. J. H. Tsado	Agricultural Extension and Rural Development
Prof. A. Aremu	Animal Production
Dr. M. S. Salaudeen	Crop Production Technology
Dr. O. B. Ocheme	Food Science and Technology
Dr. P. A. Tsado	Soil Science and Land Management
Prof. M. S. Tsado	Water Resources, Aquaculture and Fishery Technology

**EDITORIAL BOARD OF JOURNAL OF AGRICULTURE AND AGRICULTURAL TECHNOLOGY**

Prof. J. N. Nmadu	Editor-in-Chief
Dr. C. E. Chinma	Editorial Manager
Dr. M. A. Ojo	Business Manager
Dr. A. Usman	Member
Dr. L. Y. Bello	Member
Dr. A. M. Orire	Member
Dr. P. A. Tsado	Member
Dr. O. J. Ajayi	Secretary

**LOCAL ORGANISING COMMITTEE (LOC)**

Prof. J. N. Nmadu	Chairman
Dr. L. Y. Bello	Member
Dr. C. E. Chinma	Member
Dr. A. Usman	Member
Dr. M. A. Ojo	Member
Dr. A. M. Orire	Member
Dr. P. A. Tsado	Member
Dr. O. J. Ajayi	Member

**TECHNICAL SUB-COMMITTEE**

Dr. C. E. Chinma	Chairman
Prof. S. O. E. Sadiku	Member
Prof. R. S. Olaleye	Member
Prof. A. S. Gana	Member
Prof. A. Aremu	Member
Dr. A. J. Jirgi	Member
Dr. S. Olayimika	Member
Dr. B. A. Alimi	Member



### **FUND-RAISING SUB-COMMITTEE**

Dr. P. A. Tsado	Chairman
Prof. J. O. Oyero	Co-Chairman
Dr. A. A. A. Coker	Member
Dr. A. Usman	Member
Dr. Zubairu Yakubu	Member

### **ENTERTAINMENT SUB-COMMITTEE**

Dr. M. A. Ojo	Chairman
Dr. Mrs. S. Ibrahim	Member
Dr. Mrs. A. O. Ojo	Member
Mrs. O. A. Addiran	Member
Mrs. S. T. Azeez	Member
Mrs. A. Banjo	Member

### **PUBLICITY AND PROTOCOL SUB-COMMITTEE**

Dr. L. Y. Bello	Chairman
-----------------	----------

### **LOGISTICS SUB-COMMITTEE**

Dr. Usman Abdulkadir	Chairman
----------------------	----------

### **SCHOOL OF AGRICULTURE AND AGRICULTURE TECHNOLOGY**

The School of Agriculture and Agriculture Technology was established in January 1986 with two Departments (Animal Production and Crop Production) and four pioneer academic staff (Dr. Z. Stecki, Dr. S. Plonka, Mr. E. K. Tsado and Mr S. L. Lamai). With subsequent development, four more departments (Soil Science and Land Management, Water Resources, Aquaculture and Fisheries Technology and Agricultural Economics and Farm Management and Agricultural Extension and Rural Development) were created.

The Department of Soil Science started as a Unit under the Department of Crop Production in 1987 and attained full status as a Department in 1988 and name was changed to Department of Soil Science and Land Management. The Department of Fisheries Technology, now known as Department of Water Resources, Aquaculture and Fisheries Technology started in 1987 as a Unit in the department of Animal Production which transformed to the Department of Animal Production and Fisheries Technology in 1989 and was split into department of Animal Production and Department of Fisheries Technology in 1991. The Department was repackaged and renamed Department of Water Resources, Aquaculture and Fisheries Technology in 2006. A new Unit, Agricultural Economics and Extension Technology was created during the 1997/1998 section under the Department of Crop Production. The Unit was separated from the mother Department and upgraded to a full-fledge Department in 2002. Approval has also been given for creation of Department of Agricultural Extension and Rural Development while the mother Department will henceforth bear Department of Agricultural Economics and Farm Management.

In 1997, the proposed Department of Food Science and Nutrition took off as a Unit in the Department of Animal Production and became a full-fledged Department of Food Science and Technology. Similarly, the Horticulture unit has emerged in the Department of Crop Production and it is hoped that, in due course, a separate Department of Horticulture will be created.

The student intake into the School at inception in 1986 stood at two (one student each for Department Of Animal Production and Department Of Crop Production), and these graduated in 1989. Since then, the school has witness tremendous progress in terms of staff recruitment and development, infrastructural development and student enrolment. Today, the staff and student population stand at 107 and 1,444 respectively.

Dr. Z. Stecki was the first Coordinator for the school (1986 September 1988). Dr. E.A. Salako took over as School Coordinator from October 1988 to 1990 and served later as Acting Dean until he became the only Professor in the School when he was made the Dean. After his tenure, the School reverted to the position of Acting Deanship since no Professor was on ground then. These were Dr. J.A. Oladiran (1995-1998) and Dr. S.L. Lamai (1998-2001). By September 2001, with more Professors on ground portraying the extent of development, the Board of School Of Agriculture And Agricultural Technology, in accordance with the University regulations, elected Prof.O.O.A. Fasanya as the Dean of the School for a two-year term. Since then, the Deanship position in the School has been filled by election. Prof. E.A. Salako took over from Prof O.O. A. Fasanya in 2003 and Prof. S.L. Lamai took over from Prof. E.A. Salako in 2005. In January 2008, following the appointment of Prof. S.L. Lami as the dean of postgraduate school, Prof. K.M. Baba assumed Deanship of the School. In February 2012, Prof. M.G.M. Kolo succeeded Prof. K.M. Baba who had completed his second two-year term. Professor Kolo was re-elected another term of two years from February, 2014. While servicing the second term, he was appointed Dean of Postgraduate School which necessitated another election leading to the emergence of Prof. R.J. Kolo the new Dean in March 2015. Following the completion of the second term of Prof. Kolo, elections were conducted and Prof. A. J. Odofin emerged as the Dean as from 9<sup>th</sup> of April, 2019.

## **INTERNATIONAL CONFERENCE OF AGRICULTURE AND AGRICULTURAL TECHNOLOGY**

The Committee of the 1st International Conference of Agriculture and Agricultural Technology (ICAAT 2018) is pleased to announce the conference. This conference is an avenue to disseminate innovative research results and latest development in technologies related to agriculture which are aimed at fighting food insecurity. The conference will bring together leading researchers and scientists in agriculture and allied fields, and even commoners in the domain of interest from around Africa and the world. This international conference brings together experts, intelligentsia and potential researchers from various fields of agriculture to cross-fertilize ideas and ponder on the recent innovations and techniques for the sustainable development aimed at fighting food insecurity in Africa. Therefore, during the three-day conference, all participants will have plenty of opportunities for exchanging ideas, findings and

the latest research results and exploring the rich culture of the Nupe and Gbagyi kingdoms in central Nigeria.

### PROGRAMME OF ACTIVITIES

<b>DAY 1: TUESDAY, APRIL 23</b>			
<b>Time</b>	<b>Activity</b>		
7.00-6pm	Arrival		
<b>DAY TWO: WEDNESDAY, APRIL 24</b>			
8.00 am-	Registration of Participants		
8.00 -9.00	BREAKFAST		
9.00-11.00	<p align="center"><b>PLENARY SESSION</b></p> <p align="center">Paper 1 Seed yield and physiological seed quality of cowpea varieties sown at different planting dates in Minna, Southern Guinea Savanna of Nigeria by Mrs. O.A. Adediran</p> <p align="center">Paper 2 Performance of soybean genotypes under <i>Rhizobia</i> inoculation across three Agro ecologies of Nigeria by Dr. K.D. Tolorunse</p>		
11.00-1.00	<b>TECHNICAL SESSION 1</b>		
	<p align="center"><b>Hall 1</b></p> <p align="center">Prof. A.S. Gana (Chairman) Dr. B. A. Alimi (Rapporteur) Abstract no.: 1,2,3,4,5,6,7,8,9,10</p>	<p align="center"><b>Hall 2</b></p> <p align="center">Prof. E.K. Tsado (Chairman) Dr. E. Daniya (Rapporteur) Abstract no.: 11,12, 15,16,17,18,19,20,21,90</p>	<p align="center"><b>Hall 3</b></p> <p align="center">Prof. K.M.Baba (Chairman) Dr. O. J. Alabi (Rapporteur) Abstract no.: 22,23, 25,26,27,28,29,31, 76, 103</p>
1.00-2.00	<b>BREAK/LUNCH</b>		
	2.00-3.30	<b>TECHNICAL SESSION 2</b>	
	<p align="center"><b>Hall1</b></p> <p align="center">Prof. S.O.E. Sadiku (Chairman) Dr. S.S.A.Egena (Rapporteur) Abstract no: 32 .35,36,37,38,39,40,41,42, 75</p>	<p align="center"><b>Hall 2</b></p> <p align="center">Prof. A. Aremu (Chairman) Dr. C.O.Adebayo (Rapporteur) Abstract no: 43,44,45,47,48,49,50,51,52, 104</p>	<p align="center"><b>Hall 3</b></p> <p align="center">Prof. B.A.Ayanwale (Chairman) Dr. M. Ibrahim (Rapporteur) Abstract no: 53,54,55,56,57,59,60,61,62, 102</p>
<b>DAY THREE: THURSDAY, APRIL 25</b>			
8.00-9.00	BREAKFAST		
8.00-10.00	Arrival of Guests and Dignitaries		
10.00-10.15	National Anthem/Prayer		
10.15-10.30	Introduction of Guests		

10.30-10.45	Opening Address by Chairman of the Occasion		
10.45-11.15	Keynote Address		
11.15-12.00	Goodwill Messages		
	12.00-1.30 Break/Lunch		
	1.30-3.00	<b>TECHNICAL SESSION</b>	
	<b>Hall 1</b> Prof. R.S. Olaleye(Chairman) Dr. E.Z. Jiya (Rapporteur) Abstract no: 30, 33 46, 65,66,67,68,69,70,71,72,73,7 4	<b>Hall 2</b> Prof. A.T. Ijaiya (Chairman) Dr. A.A.A. Coker (Rapporteur) Abstract no:77,78, 79,80,81,82, 83,84,85,86,87,88,89	<b>Hall 3</b> Prof. J.O.Oyero (Chairman) Dr. K.D. Tolorunse (Rapporteur) Abstract no: 24,91,92,93,94,95,96,97,98, 99,100,101
3.00-4.15	Communique and Formal closing		
4.30 – 6.00	Cocktail		





## TABLE OF CONTENTS

TABLE OF CONTENTS	i
EFFECTS OF KNOWLEDGE OF HAND WASHING, SOURCES OF WATER AND ENVIRONMENTAL HYGIENE OF FARMING HOUSEHOLDS ON SUSTAINABLE AGRICULTURE IN NORTH-CENTRAL NIGERIA	1
Salihu, I. T. <sup>1</sup> , G.B. Adesiji <sup>2</sup> , A. Abdullahi <sup>1</sup> and H.U. Muhammed <sup>1</sup> .	1
FARMERS' PERCEPTION ON CLIMATE CHANGE ADAPTATION ON MAIZE PRODUCTION: A CASE STUDY OF AGAIE LGA OF NIGER STATE	13
Mohammed <sup>1*</sup> , S., I. Usman <sup>2</sup> , A. A. Oke <sup>3</sup>	13
COMPARATIVE EVALUATION OF THE EFFICIENCY OF TRADITIONAL AND MODIFIED MALIAN TRAPS IN CAPTURE FISHERIES	20
J.Yusuf <sup>1*</sup> , S.L. Lamai <sup>2</sup> ,	20
MOLECULAR IDENTIFICATION OF VIRUSES INFECTING CASSAVA IN SELECTED LOCAL GOVERNMENT AREAS OF OYO STATE, NIGERIA	28
Salaudeen*, M. T., Adeleke, I. A., Adama, C. J. and Muhammad, A. N.	28
OCCURRENCE AND DISTRIBUTION OF PEPPER ( <i>Capsicum spp.</i> ) VIRUSES IN NIGER STATE, NIGERIA	36
Adama*, C. J., Salaudeen, M. T. and Bello, L. Y.	36
EFFECT OF EGG WEIGHT AND HATCH WEIGHT ON GROWTH PERFORMANCE AND LINEAR BODY MEASUREMENTS OF FULANI ECOTYPE CHICKENS	44
Falowo , O. A., Y. Sulaiman., Ayoola, A., Adama, T. Z., Egena, S.S.A., Banjo*, A.A	44
FACTOR ANALYSIS OF FARO 44 TECHNOLOGIES ADOPTION AMONG FARMERS UNDER FADAMA III AF IN NIGER STATE. NIGERIA	49
Ibrahim <sup>1</sup> , M. and Mohammed <sup>1</sup> , U. S.	49
AGRONOMIC PERFORMANCE OF CHICKPEA ( <i>CICER ARIETINUM L.</i> ) VARIETIES UNDER VARIED PHOSPHORUS LEVELS AT EJERSA LAFO DISTRICT, WEST SHOWA ZONE, CENTRAL ETHIOPIA	58
Chala Chalchissa <sup>1</sup> , Habtamu Ashagre <sup>2</sup> , Ibrahim Hamza <sup>3*</sup>	58
INTRODUCTION	58
METHODOLOGY	59
TREND ANALYSIS AND THE DETERMINANTS OF RICE CONSUMPTION IN NIGERIA (1970 – 2016)	72
Elega*, J. O., L. Tanko, M.A. Ojo	72

EXPOLATORY ANALYSIS OF CONSTRAINTS TO LIVELIHOOD DIVERSIFICATION AMONG IFAD-VCDP FARMERS IN BENUE STATE, NIGERIA	78
Sallawu <sup>1*</sup> , H., Nmadu <sup>1</sup> , J. N., Coker <sup>1</sup> , A. A. A. and Mohammed <sup>1</sup> , U. S.	78
GROWTH AND SURVIVAL OF WILD <i>SAROTHERODON GALILAEUS</i> AND <i>COPTODON ZILLII</i> RAISED IN A HAPAS-IN-POND SYSTEM	88
<sup>1*</sup> Ibrahim, A., <sup>2</sup> S. L. Lamai, <sup>3</sup> S. M. Tsadu, <sup>4</sup> S. J. Oniye.	88
DEVELOPING INTELLIGENT WEED COMPUTER VISION SYSTEM FOR LOW-LAND RICE PRECISION FARMING	94
Olaniyi, O. M. <sup>1,a</sup> , Daniya, E. <sup>2,b</sup> , Abdullahi, I.M <sup>1</sup> , Bala, J. A <sup>3</sup> ., Olanrewaju, A. E <sup>1</sup> .	94
ARIMA MODELLING OF COCOA PRODUCTION IN NIGERIA: 1900-2025	107
Joshua Olusegun Ajetomobi <sup>1*</sup> and Adesola Olutayo Olaleye <sup>2</sup>	107
SEED YIELD AND PHYSIOLOGICAL SEED QUALITY OF COWPEA VARIETIES SOWN AT DIFFERENT PLANTING DATES IN MINNA, SOUTHERN GUINEA SAVANNA OF NIGERIA.	117
O. A. Adediran <sup>1*</sup> , H. Ibrahim <sup>1</sup> , J. A. Oladiran <sup>1</sup> , U. Yakubu <sup>1</sup> and O. A. Adesina <sup>1</sup>	117
EFFECT OF ROASTED SENNA <i>OCCIDENTALIS</i> SEED MEAL ON THE CARCASS CHARACTERISTICS ,MEAT TO BONE RATIO AND ORGAN PROPORTION OF INDIGENOUS GUINEA FOWLS ( <i>NUMIDEA MELEAGRIS GALLEATA</i> ) UNDER INTENSIVE SYSTEM	127
Kudu, Y.S., Ayanwale, B.A., A.Aremu, A.T. Ijaiya, A.A. Malik and M.J. Ibrahim	127
EFFECTS OF BUTYLATED HYDROXY TOLUENE ON THE KEEPING QUALITY OF <i>KULIKULI</i> , A NIGERIAN SNACK.	133
James <sup>1*</sup> , S., L. Nwokocha <sup>2</sup> , L. Akinsoji <sup>1</sup> , A. I. Baba <sup>1</sup> , Y. Audu <sup>1</sup> , Y. M. O. Maxwell <sup>1</sup>	133
EFFECT OF STORAGE TEMPERATURE ON SEEDLING GROWTH OF OKRA ( <i>Abelmoschus esculentus</i> [L.] Moench) CULTIVARS	138
Joseph*, E. C., Tolorunse, K. D. and Adama, C. J.	138
RELATIONSHIP BETWEEN WATER VOLUMES, SHAPES, GLASS THICKNESSES AND WATER HOLDING CAPACITY OF 40 LITRES GLASS AQUARIA	146
Olayimika, S. O. A*, Lamai, S. L**, Olugboji, O. A*** and Garkida, A. D.****	146
AGRICULTURAL DIVERSIFICATION FOR FOOD SECURITY IN SUB-SAHARAN AFRICA: EMPIRICAL EVIDENCE AND POLICY PROVISIONS UNDER NIGERIA'S AGRICULTURE PROMOTION POLICY	152
Coker <sup>1*</sup> , A. A. A., A. A. Ogundeji <sup>2</sup> , B. Khadijat <sup>1</sup> , A.J. Jirgi <sup>1</sup> , H. Sallawu <sup>1</sup> and B. A. Sule <sup>3</sup>	152
EFFECT OF SCARIFICATION AND DIPPING DURATION ON THE SEEDLING EMERGENCE AND GROWTH OF GOLDEN SHOWER TREE ( <i>Cassia fistula</i> LINN)	169



H. M. Ibrahim <sup>1*</sup> , Z. O Jubril <sup>1</sup> , B.K. Ameh <sup>1</sup> , R. O. Oyewale <sup>1</sup> , O. M. Olosundes <sup>2</sup> , L. A. Hammed <sup>2</sup> , M. A. Adebisi <sup>2</sup> ,	169
MACROECONOMIC POLICY MANAGEMENT FOR SUSTAINABLE FOOD SECURITY OUTCOME IN NIGERIA	178
UKPE, U. H.* <sup>1</sup> , C. R. F. DJOMO <sup>2</sup> , S. A.OLAYIWOLA <sup>1</sup> and AUDU, I. A.. <sup>1</sup>	178
SEED QUALITY STUDY IN PEPPER ( <i>Capsicum annuum</i> Linn.) USING SEEDLING EMERGENCE AND ELECTRO-CONDUCTIVITY AS INDICES	186
Ibrahim <sup>1</sup> , H., Yusuf <sup>1</sup> , S.T., Adediran <sup>1*</sup> , O.A., Muhammad <sup>1</sup> , A.N and Adewumi <sup>1</sup> , O.A.	186
GROWTH AND YIELD RESPONSE OF MAIZE ( <i>Zea mays</i> L.) VARIETIES TO DIFFERENT LEVELS OF NITROGEN FERTILIZER APPLICATION IN MINNA, NIGERIA.	196
Saidu <sup>1*</sup> A., Mamudu, <sup>1</sup> A.Y., Oladele <sup>1</sup> E. R. <sup>2</sup> Ndagana Muhammed Kolo	196
GROWTH PERFORMANCE OF POP CORN AS INFLUENCED BY NITROGEN FERTILIZER RATE AND INTRA-ROW SPACING AT BADEGGI, NIGERIA	202
M.K Ndagana <sup>1</sup> and Adamu Saidu <sup>2</sup>	202
PRICE BEHAVIOUR OF LOCAL AND IMPORTED RICE IN RURAL AND URBAN MARKETS OF NIGER STATE, NIGERIA	210
Bako <sup>1*</sup> , R.U., F.D. Ibrahim <sup>1</sup> , C.O. Adebayo <sup>1</sup> and U.S. Mohammed <sup>1</sup>	210
TOWARDS AN INTELLIGENT FARMLAND INTRUSION DETECTION AND VANDALIZATION PREVENTION SYSTEM USING DEEP LEARNING AND RASPBERRY PI	218
Abdullahi, I.M <sup>1</sup> , Olaniyi, O. M <sup>2</sup> ., Maliki D <sup>3</sup> , Ayansina, E. A <sup>4</sup> , Ijah, J. U <sup>5</sup>	218
EFFECTS OF BIOCHAR DERIVED FROM DIFFERENT FEEDSTOCK ON COWPEA PRODUCTIVITY IN MINNA, SOUTHERN GUINEA SAVANNA OF NIGERIA.	227
*Adekanmbi, <sup>1</sup> A.A., Afolabi, <sup>1</sup> S.G., Umar, <sup>1</sup> A.O., Fagbenro, <sup>2</sup> J.A., Bala, <sup>1</sup> A. and Osunde, <sup>1</sup> O.A.	227
PREDICTION OF INFILTRATION RATES OF FALLOW AND CULTIVATED SOILS IN MINNA, SOUTHERN GUINEA SAVANNA ZONE OF NIGERIA	238
Eze, P. C.	238
EFFECT OF METHOD AND RATE OF APPLICATION OF RICE HUSK-RESIDUE ON MAIZE PLANT HEIGHT AND YIELD IN MINNA, NIGERIA.	245
Eze <sup>1*</sup> , P. C., I. N. Onyekwere <sup>2</sup> , I. A. Balogun <sup>1</sup> , P. A. Tsado <sup>1</sup> and C. E. Azuatalam <sup>3</sup>	245
A REVIEW OF THE CONSTRAINTS OF THE USAGE OF E-AGRICULTURE AND OPPORTUNITIES IN CEREAL CROP FARMING IN AFRICA	251
*Mshelizah R.J., *Ajayi, O. J., *Tsado, J. H., & * M.Ibrahim	251

A REVIEW OF THE CHALLENGES INVOLVED IN CEREAL CROP FARMING AND SUGGESTED ACTIONS ON THE WAY FORWARD IN CEREAL CROP FARMING IN AFRICA	258
*Mshelizah R.J., *Ajayi, O. J., *Tsado, J. H., & * M.Ibrahim	258
PERFORMANCE OF SOYBEAN GENOTYPES UNDER RHIZOBIA INOCULATION ACROSS THREE AGRO ECOLOGIES OF NIGERIA	273
Tolorunse <sup>1*</sup> , K. D., Gana <sup>1</sup> , A.S., Sangodele <sup>2</sup> , E. A. and Ngwu , C. H.	273
MARKET INTEGRATION OF SESAME SEEDS IN SOUTH ASIA	282
*Sadiq, M.S <sup>1</sup> ., Singh, I.P <sup>2</sup> ., Lawal, M <sup>3</sup> . and Muhammad, H <sup>4</sup> .	282
NATURAL FEED ADDITIVES FOR SUSTAINABLE ANIMAL PRODUCTION: BAKER'S YEAST ( <i>SACCHAROMYCES CEREVISIAE</i> ) SUPPLEMENTED-DIET IMPROVED NITROGEN (N) ABSORPTION IN RABBITS	294
Shehu <sup>1*</sup> , B. M. and Ayanwale <sup>2</sup> , B. A.	294
RESPONSE OF COWPEA TO RHIZOBIAL INOCULATION IN SOILS OF SOME COWPEA GROWING AREAS OF NIGER STATE	298
Tanko, F., D.T Ezekiel-Adewuyin., A. O. Osunde, and A. Bala	298
BODY COMPOSITION AND NUTRIENT UTILIZATION OF <i>Clarias gariepinus</i> FINGERLINGS FED COOKED <i>Albizia lebbek</i> SEED MEAL	309
Orire <sup>1*</sup> , A. M., O.J. ESTHER <sup>1</sup>	309
AGROCHEMICAL SAFETY AND HEALTH INFORMATION USAGE AMONG FARMERS IN NIGERIA.	315
Jibrin, S. <sup>1</sup> , O.J.Ajayi <sup>1</sup> , I.T. Salihu <sup>1</sup> , L. Y. Bello and A. Umar <sup>3</sup>	315
GROWTH PERFORMANCE AND NUTRIENT DIGESTIBILITY OF BROILER CHICKENS FED DIETS CONTAINING SHEA BUTTER CAKE FERMENTED WITH <i>Aspergillus niger</i>	323
Ewa <sup>1*</sup> , E. C., E. Z. Jiya <sup>2</sup> , O. A. Amao <sup>3</sup> , A. D. Ojo <sup>4</sup>	323
CARCASS CHARACTERISTICS, CARCASS COMPOSITION AND MEAT QUALITY OF BROILER CHICKENS FED DIETS CONTAINING SHEA BUTTER CAKE FERMENTED WITH <i>Aspergillus niger</i>	330
Jiya <sup>1</sup> , E. Z., E. C. Ewa <sup>2*</sup> , M. B. Tihamiyu <sup>3</sup>	330
EFFECT OF RURAL YOUTHS MIGRATION ON MAIZE PRODUCTION IN KONTAGORA LOCAL GOVERNMENT AREA OF NIGER STATE, NIGERIA	338
Abdullahi <sup>1</sup> , A., Baba <sup>2</sup> , K.M. and Salihu <sup>1</sup> , I. T.	338
PROXIMATE COMPOSITION, MICRONUTRIENT AND SENSORY PROPERTIES OF COMPLEMENTARY FOOD FORMULATED USING SOME SELECTED CEREALS	346

Okwori, E.,	346
PALATABILITY AND ACCEPTABILITY STUDY OF SPROUTED SORGHUM AS AN IMPROVED CEREAL CROP FOR HOUSEHOLD USE	352
<sup>1</sup> Okwori, E., <sup>2</sup> Gaminana. Z. <sup>1</sup> Onu, R.O., and <sup>1</sup> Mustapha, A.K	352
NUTRIENT DIGESTIBILITY AND CARCASS CHARACTERISTICS OF WEANER RABBITS ( <i>Oryctolagus cuniculus</i> ) FED GRADED LEVELS OF BOILED PELLETED NEGRO COFFEE ( <i>Senna occidentalis</i> ) SEED MEAL.	359
Kudu, Y.S., M.J. Ibrahim, A. O. Abdulmalik and A. A. Malik.	359
OCCURRENCE AND DISTRIBUTION OF MAIZE STEM BORERS IN SOME SELECTED LOCAL GOVERNMENT AREAS OF NIGER STATE, NIGERIA	364
Oyewale <sup>1</sup> , R.O., Salaudeen <sup>1</sup> , M.T.,Bamaiyi <sup>2</sup> ,L.J.,Bello <sup>1</sup> , L.Y., Usman <sup>1</sup> , M.B. &Adeyemo <sup>1</sup> , J.M.	364
UTILIZATION OF POST HARVEST TECHNOLOGIES AMONG YAM FARMERS IN SELECTED LOCAL GOVERNMENT AREAS OF NIGER STATE, NIGERIA	369
Hassan <sup>1*</sup> , S., Salihu <sup>2</sup> , I. T., Abdullahi <sup>2</sup> , A., and Aliyu <sup>1</sup> , A.	369
EFFECT OF TILLAGE AND WEED CONTROL METHODS ON THE GROWTH AND YIELD OF MAIZE ( <i>Zea mays</i> L)	378
Adesina, O. A. <sup>1*</sup> A.P. Ajakpovi <sup>2</sup> . H.A Ibrahim <sup>3</sup>	378
MAPPING OF PHYTOPLANKTON COMPOSITION AND ABUNDANCE IN TAGWAI DAM RESERVOIR NIGER STATE, NIGERIA	387
Ibrahim <sup>1*</sup> , S. U., A. T. Yisa <sup>2</sup> , A. Ibrahim <sup>3</sup> , I. H. Abah <sup>4</sup>	387
INTERACTIONS BETWEEN CROP GENOTYPIC DIVERSITY AND TILLAGE	393
* Adekanmbi A.A. <sup>1,2</sup> and D. Johnson <sup>1</sup>	393
DEVELOPMENT AND ASSESSMENT OF ROUND BOTTOM FERROCEMENT CANOE FOR ARTISANAL FISHERY IN KAINJI LAKE BASIN.	403
* Ibrahim. A, **R.J Kolo and ** S.O.E Sadiku	403
RESPONSE OF COWPEA ( <i>Vigna unguiculata</i> L. Walp) TO APPLICATION OF STARTER NITROGEN IN MINNA, NIGERIA	409
Afolabi*, S.G., Adeboye, M.K.A. and Ohiare, N.M.	409
MEAT QUALITY AND SENSORY PROPERTIES OF BROILER CHICKENS FED COMMERCIAL DIETS	416
Shadawo. Y.J., Jiya, E. Z., Kudu, Y.S.and Adigun, U.O.	416
WILLINGNESS TO PAY FOR SAFE BEEF CONSUMPTION IN KONTAGORA LOCAL GOVERNMENT AREA OF NIGER STATE, NIGERIA	422



Oseghale <sup>1*</sup> A. I., S. Akinsola <sup>1</sup> , T.O Olarewaju <sup>2</sup>	422
DIETARY PROTEIN REQUIREMENT FOR GROWTH PERFORMANCE AND NUTRIENT DIGESTIBILITY OF FUNAAB ALPHA BROILER CHICKENS	429
Olawuyi, D.O., Alabi, O.J., Jiya, E.Z., Egena S.S.A. and Alemede, I.C.	429
GROWTH PERFORMANCE AND NUTRIENT DIGESTIBILITY OF BROILER CHICKENS FED WOOD ASH BASED DIETS AT BOTH STARTER AND FINISHER PHASES	435
Alabi, O.J., Alemede, I.C. Egena S.S.A, Obari, O.C. Ewa, E.C, and Oyinloye, J.O.	435
AN ASSESSMENT OF FARMERS AWARENESS AND PERCEPTION ON USE OF SOIL INFORMATION IN NIGER STATE	446
Abdurasak <sup>1*</sup> , Y. L., B. A. Lawal <sup>1</sup> , B. A. Raji <sup>2</sup> ., M. Yakubu <sup>3</sup> ., A. A. Panti <sup>4</sup>	446
ARTIFICIAL IMMUNE SYSTEM (AIS) ALGORITHMS FOR CROPS CLASSIFICATION USING PRINCIPAL COMPONENTS ANALYSIS	453
* <sup>1</sup> Akinwande, O.T and <sup>2</sup> Abdullahi, M.B	453
INTERNET OF THINGS (IOT): EMERGING TOOL FOR FOOD SECURITY IN AGRICULTURE	462
Bamigboye <sup>1*</sup> , F. O., E. O. Ademola <sup>2</sup>	462
CHEMICAL COMPOSITION, PHYSICAL AND SENSORY PROPERTIES OF CAKES PREPARED FROM FLOUR BLENDS OF WHEAT AND CASHEW NUT KERNELS.	467
Yakubu, C. M.*, James, S., Maxwell, Y. M. O., Joseph F., Ocheme, O. B. and Zubair B. A.	467
MICROBIAL EVALUATION OF BOILED EGGS SOLD IN RETAIL OUTLETS IN ZARIA, NIGERIA	477
Kolo <sup>1*</sup> , H. N., E. C. Okolocha <sup>2</sup> , F. U. Samuel <sup>3</sup> , P. S. Kolo <sup>1</sup> , A. A. Banjo <sup>1</sup> , C. E. Ewa <sup>1</sup> and S. O. Azeez <sup>4</sup>	478
INFLUENCE OF WATTLE ON HAEMATOLOGY AND SERUM BIOCHEMISTRY OF RED SOKOTO BUCKS KEPT SEMI-INTENSIVELY IN NIGER STATE, NIGERIA	484
Kolo <sup>1*</sup> , P. S., Alemede, I.C., Egena, S. S. A. and Adama, J. Y.	484
INFLUENCE OF CLIMATE CHANGE ON THE LENGTH OF GROWING SEASON IN MINNA, NIGER STATE (2006-2016)	488
Rita Edoga and Lukman Animashaun	488
PERFORMANCE OF FUNAAB ALPHA BROILER CHICKENS FED DIFFERENT DIETARY ENERGY LEVELS UNDER A SINGLE PHASE FEEDING	494
Akigbogun*, K.I., Alemede, I.C. and Egena, S.S.A.	494
CLIMATE ADAPTATION MEASURES BY IFAD-VCDP RICE FARMERS IN WUSHISHI LOCAL GOVERNMENT AREA, NIGER STATE, NIGERIA.	497
Jirgi, A. J. <sup>1</sup> , J. G. Tuedogheye <sup>1</sup> , A. O. Simon <sup>1</sup> , A. I. Oseghale <sup>1</sup>	497

SOCIOECONOMIC DETERMINANTS OF ADOPTION LEVELS OF ADAPTIVE YAM MINISSETT TECHNOLOGY BY FARMERS IN FEDERAL CAPITAL TERRITORY, NIGERIA	505
Otene <sup>1*</sup> , N. U., J. H. Tsado <sup>1</sup> , I. T. Salihu <sup>1</sup>	505
LIVELIHOOD DIVERSIFICATION AND INCOME INEQUALITY AMONG HOUSEHOLDS IN MINNA METROPOLIS NIGER STATE	512
*Ogaji, A., Adewumi, A., Ibrahim, M. and Ocheja, F. A.	512
CHARACTERIZATION AND SUITABILITY CLASSIFICATION OF SOME PLINTHIC LANDSCAPES FOR OIL PALM PRODUCTION IN NIGER STATE, NIGERIA	520
Lawal*, B. A., A. I. Kolo, M. K. A. Adeboye, P. A., Tsado, A. Mohammed.	520
ANALYSIS OF ARTISANAL AND CULTURED FISH PRODUCTION IN NIGER STATE, NIGERIA	526
Tsado, J.H., Nmadu J.N., Baba K.M., Jirgi A.J., Ebiloma G.C.	526
EFFECT OF CLIMATE CHANGE ON FOOD SECURITY AND WELL-BEING OF RICE FARMERS IN KEBBI AND NASARAWA STATES, NIGERIA	534
Fatoki <sup>1*</sup> , P. O., J. H. Tsado <sup>2</sup> , O. J. Ajayi <sup>3</sup> I. T. Salihu <sup>4</sup>	534
ANALYSIS OF THE DETERMINANTS OF PROFIT EFFICIENCY OF SMALL-SCALE MAIZE FARMERS IN SOME SELECTED LOCAL GOVERNMENT AREA OF OSUN STATE, NIGERIA	541
Ojo A.O., Akande, N.O. and Ojo, M.A	541
SILAGE QUALITY AND PROXIMATE COMPOSITION OF <i>PANICUM MAXIMUM</i> (GUINEA GRASS) ENSILED WITH GRADED LEVELS OF HONEYCOMB WASTE	553
Bamigboye <sup>1*</sup> , F. O., T. A. Ogunnusi <sup>2</sup>	553
BREEDING OF <i>Clarias gariepinus</i> (BURCHELL, 1822) USING WATER LILY LEAF AS SUBSTRATE FOR INCUBATION	560
Gana <sup>1*</sup> , A. B., S. M. Tsadu <sup>2</sup> , R. Ibrahim <sup>3</sup> , T. Iriobe <sup>4</sup>	560
INFLUENCE OF MINERAL NITROGEN-LEVELS AND FOLIAR FERTILIZER ON INOCULATED SOYBEAN NODULATION, GROWTH AND YIELD	566
Ezekiel.-Adewoyin D. T. <sup>1</sup> , Tanko F <sup>1</sup> ., Shokalu A. O. <sup>2</sup> , Emmanuel C. O. <sup>2</sup> , Kayode C. O. <sup>3</sup> ., Makinde A. I. <sup>3</sup>	566
ADOPTION OF SOIL HEALTH PRACTICES BY SMALL-SCAL FARMERS IN NIGER STATE, NIGERIA	577
Tsado, J. H <sup>1</sup> ., Olaleye, R. S <sup>1</sup> ., Tyabo, I. S <sup>1</sup> ., Mohammed, Y <sup>1</sup> ., Agwo, K <sup>1</sup> . and E. Mamman <sup>2</sup>	577
EFFECT OF DIFFERENT PROCESSING METHODS ON THE CHEMICAL COMPOSITION OF WATER HYACINTH LEAVES	582

Ibrahim R.*, A.B. Gana, T. Iriobe and S. B. Mustapha	582
GROWTH AND HAEMATOLOGICAL RESPONSES OF <i>Clarias gariepinus</i> (BURCHELL, 1822) FINGERLINGS FED PROCESSED BAOBAB SEED MEAL BASED DIETS	589
Alatise *, S. P., F. O. A. George **, O. Ogundele*	589
EFFECTS OF BIOCHAR AND NITROGEN FERTILIZER ON SELECTED SOIL PHYSICAL PROPERTIES AND MAIZE YIELD AT MINNA, NIGERIA	598
Azeez <sup>1*</sup> , B. A., A. J. Odofin <sup>1</sup> , M. O. Kareem <sup>1</sup> And B. M. Musa <sup>1</sup>	598
EFFECTS OF RAINFALL ON FISH COMMUNITY STRUCTURE IN AGAIE-LAPAI DAM RESERVOIR OF NIGER STATE, NIGERIA	606
Yakubu, U. P <sup>1</sup> , Yusuf, J <sup>1</sup> and Yusuf, M <sup>2</sup> .	606
DETERMINATION OF PROXIMATE, MICRONUTRIENTS AND SENSORY QUALITIES OF NON-ALCOHOLIC BEVERAGE (KUNUN GYADA) PRODUCED FROM SORGHUM ( <i>Sorghum bicolor</i> ) groundnut ( <i>Arachis hypogea</i> ) BLENDS	611
Maxwell <sup>1*</sup> , Y. M. O., B. A. Oyetunji <sup>2</sup> , O. B. Ocheme <sup>3</sup> , F. A. Femi <sup>4</sup> , J. Samaila <sup>5</sup> and C. M. Yakubu <sup>6</sup>	611
0.60±0.20 <sup>c</sup>	615
COMPARATIVE ANALYSIS OF NIGERIA AND INDIA ESSENTIAL MACRO-ECONOMIC INDICES	618
Job Nmadu <sup>1</sup> , Kpotun Baba <sup>1</sup> , Taye Amos <sup>2</sup> , Ezekiel Yisa <sup>1</sup> , Usman Mohammed <sup>1</sup> , Halima Sallawu <sup>1</sup>	618
GROWTH AND YIELD PERFORMANCE OF SOYBEAN ( <i>Glycine max</i> [L.] Merrill) GENOTYPES IN MINNA, NIGER STATE	627
Joseph*, E.C., K.D. Tolorunse, A., S. Gana	627
ADOPTION OF COWPEA PRODUCTION TECHNOLOGIES AMONG FARMERS IN DEKINA LOCAL GOVERNMENT OF KOGI STATE, NIGERIA.	632
Emeje Hassan Mohammed, Odoma Micheal Ojodale, Olajide Kolawole	632
GROWTH RESPONSE OF FOUR NEMATOPHAGOUS FUNGI IN DIFFERENT GRAIN AND BRAN MEDIA	644
Bello <sup>1*</sup> , L. Y., M. T. Salaudeen <sup>1</sup> , P. S. Chindo <sup>2</sup> , N. O. Agbeni <sup>2</sup> , M. D. Alegbejo <sup>2</sup> , A. S. Paiko <sup>3</sup>	644



## EFFECTS OF KNOWLEDGE OF HAND WASHING, SOURCES OF WATER AND ENVIRONMENTAL HYGIENE OF FARMING HOUSEHOLDS ON SUSTAINABLE AGRICULTURE IN NORTH-CENTRAL NIGERIA

Salihu, I. T.<sup>1</sup>, G.B. Adesiji<sup>2</sup>, A. Abdullahi<sup>1</sup> and H.U. Muhammed<sup>1</sup>.

<sup>1</sup>Department of Agricultural Economics and Extension Technology,  
Federal University of Technology, Minna, Niger State, Nigeria

<sup>2</sup>Department of Agricultural Extension and Rural Development, Faculty of Agriculture,  
University of Ilorin, Ilorin, Kwara State, Nigeria

Corresponding Author's email: [ibrahimtyabo @ yahoo.com](mailto:ibrahimtyabo@yahoo.com). GSM: 08069098599

### ABSTRACT

*The study assess the knowledge of hand washing, sources of water and environmental hygiene practices of farming households in North-Central Nigeria. Multi- stage simple random sampling technique was used to select 256 farming households in the study area. Interview schedule was used to elicit data from the respondents. The responses were analyzed using frequency counts and mean score. The result of the study shows that 38% of the respondents are in the age range of 31 – 40 years with a mean of 36.7 years, they had low level of education and the mean number of number of visits of health service workers to farming households is 3 times/per annum. The results revealed that majority (73.80%) of the respondents are aware of the need to always wash hands after using the toilet but the knowledge on the use soap to wash hand before eating ( 36.30%), preparing food/cooking (20.30%), changing baby's wear ( 24.20%), after defecating (19.10% ) and before feeding children (18.40%) is low in the study area. Majority of the respondents go their water for household purposes from unprotected sources such as dug well (57%) and bore holes (52%) and the majority (84%) treat their water by allowing it to stand and settle before drinking or before using it for other household purposes which is inadequate and may endanger the farming households to the vulnerability of food and water borne diseases. The use of bush and pit latrine are the major means of defecation in the households and dumping of household waste in a nearby bush is the system of waste disposal always adopted by majority (63.70%) of the households. Health extension workers and the local authorities should establish joint participatory committees to sensitize, motivate and organize food safety promotion programmes on the need to enforce some crucial food safety practices especially hand washing with soap/ash, on the danger of open defecation and poor system of waste disposal.*

**KEYWORDS:** Knowledge, Hand washing, Sources of Water, Waste disposal.

### INTRODUCTION

Much of the social and economic welfare of farmers, farm workers, and their local communities depend upon farming and therefore farming must be economically viable to be sustainable. However, health and safety of food, water and environment are of important concern for those involved in farming operations in order to ensure sustainable operation and productivity.

Incidents of food-borne diseases have become a global phenomenon; every person is at risk of food born-illness emanating from consumption of unsafe food, poor hygiene and bad source of water. Even in developed countries, one out of three consumers contract disease from food-borne pathogens each year which results to death of up to 20 persons per million (FAO, 2001). In African region, the number of consumers including farming households who are

highly vulnerable to food borne illness is growing, the high incidence of diarrhea diseases among newborns and young children are serious indications of poor food hygiene situation. Most children in the region experience five episodes of diarrhea per year and close to 800,000 children die each year from diarrhea and dehydration (Centre for Science in the Public Interest (CSPI), 2005).

Good levels of knowledge especially on hand washing towards food safety practices among farming households' food handlers and the effective use of such knowledge in food handling are imperative in ensuring the safe production, processing and preparation of food in any household. Aarnisalo *et al.* (2006) reported that, the practice of self-hygiene especially hand hygiene is crucial because hand is the major agent that transmits microorganisms and intestinal parasites to foods.

Hand washing with soap saves more lives than any simple vaccine or medical intervention. It is among the most effective and inexpensive ways to prevent diarrhoea diseases and pneumonia, which together are responsible for the high children mortality rate especially in developing countries. Yet, despite its lifesaving potentials, it is seldom practiced by many people in the world (UNICEF, 2008). The use of only water to wash hands is not an effective means to remove the filth and pathogenic microorganisms from it thereby exposing the individuals to the imminent danger of food borne diseases (Bizatu and Negga, 2010).

Improved sanitation and waste management is a critical issue in the worldwide. Proper waste disposal is essential to sustain healthy living conditions in any environment and helps to insulate the inhabitants from the threat of infectious diseases that can be transmitted especially through flies and mosquitoes which can be detrimental to the living standard of the people. The uses of open unregulated system of dumping wastes around the households are still the predominant methods of waste disposal in most developing countries including Nigeria and globally, about 2.6 billion people or 39 percent of the world population do not use improved sanitation system (William *et al.*, 2005). UNICEF/WHO (2008) reported that 44% of rural population in Africa practice open defecation. In a similar vein, Gbadegesin and Olorunfemi (2007) also reported that almost half of the rural households in Nigeria used bush/field for defecation. Improved sanitation can lead to reduction of risk of diarrhea by 36% and good hygiene practices improve overall health through reduced rates of vulnerability to food borne diseases such as pneumonia, influenza, scabies, skin and eye infections (Cairncross *et al.*, 2010 and UNICEF, 2010). Individual households' ability to use flush toilet and latrine promotes cleanliness of the environment, free it from odor and protect the inhabitants from diseases. On the contrary, the use of bush as place of excretion in the house is likely to expose them to vulnerability of diseases.

However, low income statuses of the households, poor living condition, low literacy level, unhygienic living environment and absence of infrastructural development such as poorly built houses, poor access to electricity and good/affordable water supply and have negative consequences on the living standard of the households and also hindered the adoption of hygienic food safety practices (Phaswana-Mafuya and Shukla, 2005).

Improved and better access to infrastructures like water is expected to enhance better practices, reduce

vulnerability to risks of exposure to diseases, increase farm productivity and improved standard of living of farming households. A safe and convenient water source is of paramount importance to human health and the well-being of any society. According to the report of UNESCO -WWAP (2003), rural Africans have the lowest level of access to clean water and sanitation facilities compared to other developing areas of the world. African population without access to improved sources of drinking water has increased from 280 million in 1990 to 341 million in 2006 (UNICEF/WHO, 2008). Hence, increase in access to improved affordable sources of water is not keeping pace to population growth. Phaswana-Mafuya and Shukla (2005) reported that high cost of water is among the factors hindering the adoption of hygienic food safety practices. According to UNICEF/WHO (2008), more than half (about 58%) of rural population in Africa got their water for drinking and other household purposes from unimproved sources which put them to the risks of threat of diseases and other economic consequences such as reduction in supply of farm labour as result of disability caused by water borne diseases. Absence of adequate affordable sources water either in quantity or quality can be a limiting factor in poverty alleviation and economic recovery, resulting in poor health and low productivity, food insecurity and constrained economic development (Gbadegesin and Olorunfemi, 2007). The Food Security Analysis Unit (FSAU) (2007) reported that most households especially from rural areas rely on water from unprotected sources including dug wells, bore holes and rivers. A source of water is an important determinant of safety of households' health and vulnerability of households to the risk of outbreak of food borne illnesses.

An increase in rate of awareness and implementation of proper food safety practices in many homes may help in preventing food borne illness out breaks (Adejero, 2013). Hence, food safety education of farming households will play an important role in preventing food- borne illness. Knowledge about hand washing, proper sanitation and good sources of water for households purposes especially cooking are key factors in driving change that can lead to improvement in household food safety practices (Warnock, 2007; Liu, 2007). Good levels of knowledge towards food safety among farming households and the effective practices of such knowledge in food handling helps in ensuring that safe food is produced, prepared and consumed in any household (Nee and Sani, 2011). Since most of the activities involving food handling and food preparation are mostly carried out by females, there is need to investigate the level of knowledge on hand



washing, systems of waste disposal and sources of water of farming households in order to minimize food borne disease outbreak especially at home. It is important to obtain the baseline information on food safety practices especially the aspects of knowledge of hand washing, sources of water and environmental hygiene practices of the rural farming households so that strengths and deficiencies can be noted and appropriate educational intervention can be planned. It is against this back drop the research initiative raises the following objectives to assess the knowledge of hand washing, sources of water and environmental hygiene practices of farming households in North-Central Nigeria. The specific objectives are to: describe the socio – economic characteristics of farming households in the study area; examine the level of knowledge of farming households on hand washing in the study area; assess the knowledge of farming households on importance of hand washing in the study area and assess the methods of disposal of waste, excreta and sources of water for farming households in the study area.

#### METHODOLOGY

The study was conducted in the North-central region of Nigeria which comprises six states. The region has a total land area of 296, 898 km<sup>2</sup> representing about 32% of the total land area of the country. It is located between latitude 6°30'N to 11° 20'N and longitude 2°30'E to 10°30'E. The research design was a descriptive survey method and the population of the study comprised farming households in the study area. The respondents were rural women who are in charge of the responsibility of preparing foods for the entire household. Multi stage sampling technique was employed for the study. The first stage involves random selection of two States from the North – central Nigeria which comprises of six States. The second stage involved random selection of one agricultural zone from each of the selected States. In the third stage, simple random sampling technique was also applied to select four (4) Local Government Areas (LGAs) from each of the selected agricultural zone. Furthermore, simple random sampling was equally applied to select four (4) rural areas in each of the selected LGAs and lastly, 8 farming households were randomly selected from each of the selected rural areas through simple random sampling technique. In all, a total of 256 farming households were selected for the study. Interview schedule was used to elicit data from the respondents. The responses were analyzed using frequency counts, charts and mean score.

#### RESULTS AND DISCUSSION

##### Socio-economic characteristics of the respondents:

**Age of respondents:** Age is often assumed that as human age increases the rate of experience on various activities also increases and it is most often used to classify rural population into targetable groups (Tyabo *et al.*, 2014). The result in Table 1 shows that about 38% of the respondents are in the age range of 31 – 40 years. The mean age of the respondents is 37 years which is an indication that most of the food preparers of farming households are young adults who are still strong and capable of undertaking rigorous activities in the households. This means that, the respondents are in their active age, have the ability to supply the labor required to carry out activities for food preparation for the entire farming household and this can influence their food safety practices or behaviours (Rahman *et al.*, 2012; Mohammed, 2013). This finding agrees with the report of Safefood (2002); Sanlier (2009) and Nee and Sani (2011) that food safety knowledge tends to increase with age and practice; and there was a significant difference between food safety knowledge and food preparation practices of young and adult consumers (in favour of adult consumers).

**Level of education of respondents:** This refers to the educational attainment of respondents which is not only an important determinant of adoption of new practices and but also an instrument for successful implementation of new practices that equips individuals with the required knowledge of how to make a living. Result in Table 1 reveals that most (43%) of the respondents had no formal education and only 24% of the respondents had secondary education. This implies that the educational level of the respondents was relatively low in the study area. This can be related to a similar study conducted by Musa and Akande (2003) who reported that majority of the food vendors in Ilorin had no formal education. The trend of the results may lead to low knowledge level of hand washing and environmental hygiene practices and this may increase the tendency of their exposure to the risk of food borne diseases in the study area. Low education among farming households' food handlers will lead to inadequate information on food safety practices such as hand washing and environmental hygiene that will lead reduction of incidences of outbreak of diseases (CSPI, 2005). Bizatu and Negga (2010) also reported that the habit of hand washing after defecation is significantly associated with the educational status of the respondents ( $P < 0.01$ ).

**Number of health service workers' visit or contact with farming households:** The result in Table 1 is a response of number of times the farming households have personal contact with health service workers in

the last 12 months. The result in Table 3 reveals that most (41.40%) of the respondents in the study area had 3 – 4 times contact with health service workers. The mean number of contacts between health service workers and farming households is 3 times in a year. This implies that the number of contact is low. This will have a negative impact on creation of awareness and education of farming households on food safety measures to adopt at home especially the sanitation of their environment; and on the need to use pure sources of water and to educate them on the best way to treat water for household purposes to safeguard against occurrence of food borne diseases.

The result in Table 2 indicated that majority (73.80%) of the respondents are aware of the need to always wash hands after using the toilet, while 14.80% and 11.30% of the respondents respectively gave a negative response towards knowledge of hand washing after using the toilet. This implies that majority of the respondents are aware of the need to wash hands after using toilet although this may not translate into practices or change in attitudes. Nee and Sani (2011) reported that, increase in the level of awareness or knowledge of food safety practices by households does not always produce a positive change in food handling attitudes. However, this finding is contrary to the report of Gul (2012) who reported that a great number of food handlers are not aware and do not wash their hands before handling food, after touching their body parts and after the use of toilets. From Table 2, the results also revealed that only 30.01% of the respondents indicated that it is enough just by washing hands under running water to remove dirt before touching food. In addition, 34.80% of the respondents denied the statement while, 35.20% of the respondents indicated they don't know. This implies that the knowledge level on the inadequacy of washing hand under running water to remove dirt before touching food is not enough. Washing hands only with water is not an effective means to remove the filth and pathogenic microorganisms from it (UNICEF, 2008; Bizatu and Negga, 2010).

**Knowledge of when it is important to wash hands:**

The result in Figure 1 shows that higher proportion (99.60%) or almost all of the respondents indicated that the knowledge of importance of washing hands before and after eating is crucial to food safety practices in the study area. Similarly, 89.50% of the respondents indicated their knowledge of importance of washing hands after defecating. Good levels of

knowledge towards food safety among farming households and the effective practices of such knowledge in food handling helps in ensuring that safe food is produced, prepared and consumed in any household (Nee and Sani, 2011). However, only 34.00% and 29.30% of them respectively indicated that it is important to wash hands after cleaning or changing baby wears and before preparing food or cooking. This implies that the knowledge on this aspect of food safety practices is low in the study area. This may have negative influence on sustainable farming and productivity in the study area. This may expose the farming households to the threat of diseases and also influence sustainable agricultural production especially in the supply of farm labour as result of disability caused by food borne diseases, increased in cost of health care services and diversion of attention to other non – farm activities such as taking care of sick family members. The practice of self-hygiene especially hand hygiene is crucial because hand is the major agent that transmits microorganisms and intestinal parasites to foods (Aarnisalo *et al.*, 2006).

**Knowledge of when soap is used to wash hands:**

From the result presented in figure 2, it can be deduced that only small proportions of the respondents are aware of when to use soap to wash hands. The result indicated that 36.30% of the respondents use soap to wash hand before eating, 24.20% use it after cleaning or changing baby wears, 20.30% use it before preparing food or cooking. Similarly, only 19.10% and 18.40% of them use it after defecating and before feeding children respectively. This implies that, the knowledge on the use soap on these food safety practices is low in the study area. This to say only small proportion of the rural community households' practice washing hands with soap or ash (Warnock, 2007). This has serious negative consequence on the safety of food consumed by the households which can increase their level of vulnerability to food borne disease, contaminations and reduction in farming activities. Washing hands only with water is not an effective means to remove the filth and pathogenic microorganisms from it (UNICEF, 2008; Bizatu and Negga, 2010). Hand washing with soap/ash although seldom practiced by majority of people saves more lives than any simple vaccine or medical intervention. It is among the most effective and inexpensive ways to prevent diarrhoea diseases and pneumonia, which together are responsible for the high children mortality rate



especially in developing countries (UNICEF, 2008). Personal hygiene of farming households' food preparers is a critical step in preventing food borne diseases and this can be enhanced through compulsory washing of hands with soap/ash before handling raw ingredients or foods, especially after using toilet, changing babies wear, sneezing or coughing (Abd Patah *et al.*, 2009).

**Knowledge of why it is important to wash hands with soap:** On the importance of hand washing with soap/ash, the results revealed that high proportion (95.30%) of the respondents indicated that washing of hands with soap is important in order to prevent diseases, because is a good hygiene (71.90%) and to prevent dirt from getting into mouth and food. Similarly, only about 45.70% of the respondents considered importance of washing hands with soap just for hands to smell good. The result implies that, there is high rate of awareness on the importance of hand washing with soap in the study area. This can be related to the study of Campbell (2011) who reported that washing hands with soap is important to be cleaned and reduce vulnerability to food borne diseases. In a similar vein, Cairncross *et al.* (2010) also reported that hand washing with soap reduces the risk of diarrhoea by 48%. Although hand washing with soap/ash after using toilet, after changing children's nappies and before eating or handling food saves more lives than any simple means of medical intervention (UNICEF, 2008), but increase in the level of awareness or knowledge of food safety practices by households does not always produce a positive change in food handling attitudes of the households' food preparers (Nee and Sani (2011).

**Sources of drinking water for members of the households:** The results in Table 3 show that slightly above half (57%) and (52%) of the respondents got their drinking water for members of the households through dug well and bore holes respectively. Similarly, about 38.70% use lake/pond/stream as sources of water for drinking in the households. The trend of the result is an indication that, most households rely on water from unprotected sources. FSAU, 2007; KIRDARC, 2009 reported that most households especially from rural areas rely on water from unprotected sources including dug wells, bore holes and rivers. This results to improper water quality which causes major public health problems affecting mortality rates in highly susceptible people especially in children and immune compromised patients which may lead to lower

income problems due to diseases resulting to nonproductive time (Jens *et al.*, 2009). Unimproved sources of water put the farming households to the risks of threat of diseases and other economic consequences such as reduction in supply of farm labour as result of disability caused by water borne diseases (UNICEF/WHO, 2008).

**Methods of treating water used by households to make it safe for drinking:** The result in Table 3 revealed that majority (84.00%) of the respondents only allow the water to stand and settle before drinking or before using it for other household purposes. The result further revealed that only 2.70% and 11.70% of the respondents respectively treat their water through boiling and straining through cloth. This implies that, large proportion of the respondents do not give adequate treatment to the water to make it safe for drinking in the study area. The inadequacy of treating the water as required may endanger the farming households to the vulnerability of food and water borne diseases. Hence, there is need for sensitization of farming households in the study area on how to improve their knowledge and encouragement on some feasible methods of treating water (such as boiling and cloth filtration) to make it safe for drinking and other household purposes.

**Types of toilet facility use in the households:** The results in Table 4 shows that 41.80% and 41.40% of the respondents respectively used bush and pit latrine as their means of defecation in their households while only 19.10% of the respondents have their toilets in the house. This study can be supported by the report of UNICEF/WHO (2008) that 44% of rural population in Africa practice open defecation. In a similar vein, Gbadegesin and Olorunfemi (2007) also reported that almost half of the rural households in Nigeria used bush/field for defecation. Poor sanitation, hygiene and unsafe water are responsible for high cases of diarrhea in the world especially developing countries which results to high children mortality rate (UNICEF, 2008). The use of bush for defecation by some proportion of the respondents cannot be unconnected with their poor knowledge on its effect on their health and the hazards of exposing the farming households to the vulnerability of food borne diseases through faces in the study area.

**System of waste disposal adopted by the households:** From the result in the Table 5, the system of waste disposal adopted by majority of the respondents includes "wastes are always dumped in a

nearby bush” (mean = 2.51), followed by “waste are dumped around the farm to decompose” (mean = 1.84) and “waste are dumped on the open waste collection site or open land” (mean = 1.66). The result further revealed that majority (mean = 1.27) “never dumped their waste in a pit”. This implies that majority of respondents in the study area do not always observe the proper system of waste disposal through dumping them in the pit or using/dumping them around the farm to decomposed to serve as manure. Hence, there is high tendency of farming households to be exposed to the risk of diseases especially diarrhea. Proper disposal of household wastes and improved sanitation attributes to 36% reduction in risk of diarrhea (Cairncross *et al.*, 2010). This result implies that only small proportion of the rural households properly manage their household waste by using it as fertilizer through making a compost pit. Hence, open unregulated dumps are still the predominant methods of waste disposal in most developing countries Nigeria inclusive (William *et al.*, 2005; KIRDARC, 2009).

#### **CONCLUSION AND RECOMMENDATIONS**

From the result of the study it can be inferred that majority of food preparers of farming households are young adults with low level of education and the number of visits of health service workers to farming households is also low. The knowledge level of hand washing and importance of this practice is high in the study area but the knowledge on the use of soap to wash hands before eating, preparing food/cooking, changing baby’s wear, after defecating and before feeding children is low in the study area. Majority of the households rely on water from unprotected sources which is inadequately treated to make it safe for drinking and this can endanger the farming households to the vulnerability of water borne diseases. Most of the households use bush and pit latrine as their means of defecation and waste are mostly dumped in a nearby bush in the study area. Health extension workers and the local authorities should establish joint participatory committees to sensitize, motivate and organize food safety promotion programmes on the need to enforce some crucial food safety practices especially hand washing with soap/ash, on the danger of open defecation and poor system of waste disposal. This will help to change their behaviours, perception and reduce vulnerability to diseases. The use of households’ wastes for economic benefits such as manure through composting which can serve as a good source of

organic manure should also be encouraged in the study area.

#### **AKNOWLEDGEMENTS**

I express my profound gratitude to ALLAH. “The Sustainer”, for the assistance, wisdom and guidance given to me and for seeing to the completion of this research work. My profound gratitude goes to Prof. G. B. Adesiji, my parents and family for their immeasurable contribution towards the successful contribution of this task, I remain grateful.



**Table 1: Socio-economic characteristics of respondents in the study area (n = 256)**

Characteristics	Frequency	Percentage
<b>Age (Years)</b>		
19 – 30	62	24.20
31 – 40	98	38.30
41 – 50	55	21.50
51 – 60	34	13.30
>60	7	2.70
<b>Mean = 37</b>		
<b>Total</b>	<b>256</b>	<b>100</b>
<b>Levels of education</b>		
No formal education	111	43.40
Quranic education	53	20.70
Adult education	6	2.30
Primary education	18	7.00
Secondary education	62	24.20
Tertiary education	6	2.30
<b>Total</b>	<b>256</b>	<b>100</b>
<b>Number of visits by health service workers to farm households per annum</b>		
<3 times	91	35.50
3 – 4 times	106	41.40
>4 times	59	23.00
<b>Mean = 3 times</b>		
<b>Total</b>	<b>256</b>	<b>100</b>

Source: Field survey, 2016.

**Table 2: Distribution of respondents on level of knowledge on hand washing (n = 256)**

Knowledge level on hand washing	Yes	No	I don't know	Total
	Freq.(%)	Freq.(%)	Freq.(%)	Freq.(%)
Do you know, you should always wash your hands after using the toilet?	189(73.80)	38(14.80)	29(11.30)	<b>256(100)</b>
Is it enough just by washing your hands under running water to remove dirt before touching food?	77(30.01)	89(34.80)	90(35.20)	<b>256(100)</b>

Source: Field survey, 2016.

**Table 3: Distribution of respondents according to sources of drinking water for members and methods of treating water used by households to make it safe for drinking (n = 256)**

Source (s) of water	Frequency	Percentage*
Bottle water	4	1.60
Pipe borne water	-	-
Dug well	146	57.00
Spring/river	65	25.40
Bore hole	133	52.00
Lake/pond/stream	99	38.70
Tanker/truck	1	0.40
<b>Methods of treating water</b>		
Boil	7	2.70
Strain through cloth	30	11.70
Filter for water	10	3.90
Let it stand and settle	215	84.00
Add alum	45	17.60
Don't do anything to it	13	5.10

\*Multiple responses

Source: Field survey, 2016.

**Table 4: Distribution of respondents according to type of toilet facility use in the household (n = 256)**

Types toilet facilities	Frequency	Percentage*
Pit latrine	106	41.40
Toilet inside the house	49	19.10
Bush	107	41.80

\*Multiple responses

Source: Field survey, 2016.

**Table 5: Distribution of respondents according to system of waste disposal adapted in the household (n = 256)**

Methods of disposing waste in the households	Always	Sometimes	Never	Mean (Std)	Rank
	Freq. (%)	Freq. (%)	Freq. (%)		
Waste are dumped in a nearby bush	163(63.70)	60(23.40)	33(12.90)	2.51 (0.714)	1 <sup>st</sup>
Waste are dumped around the farm to decompose	43(16.80)	130(50.80)	83(32.40)	1.84 (0.685)	2 <sup>nd</sup>
Waste are dumped on the open waste collection site or open land	52(20.30)	66(25.80)	138(53.90)	1.66 (0.795)	3 <sup>rd</sup>
Waste are used as manure on the farm	13(5.10)	144(56.20)	99(38.70)	1.66 (0.571)	4 <sup>th</sup>
Waste are dumped in the pit	-	70(27.30)	186(72.70)	1.27 (0.447)	5 <sup>th</sup>

Source: Field survey, 2016.

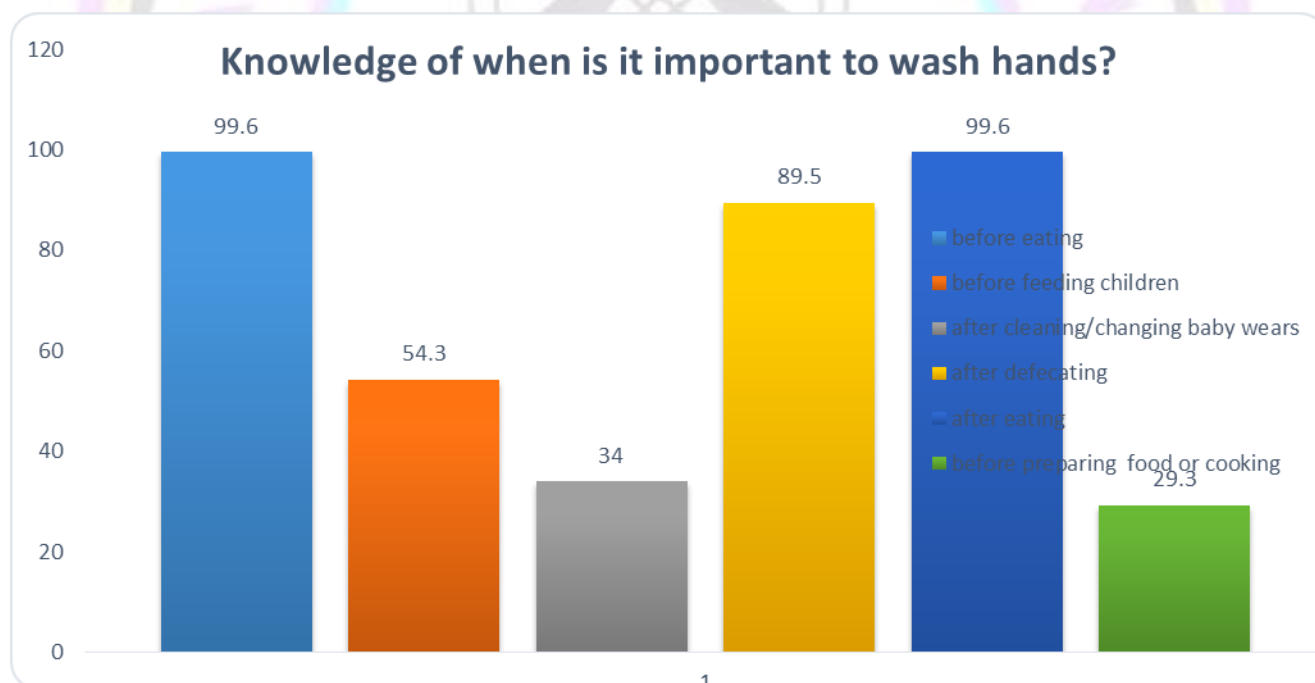


Figure1: Knowledge of when is it important to wash hands?

Source: Field survey, 2016.

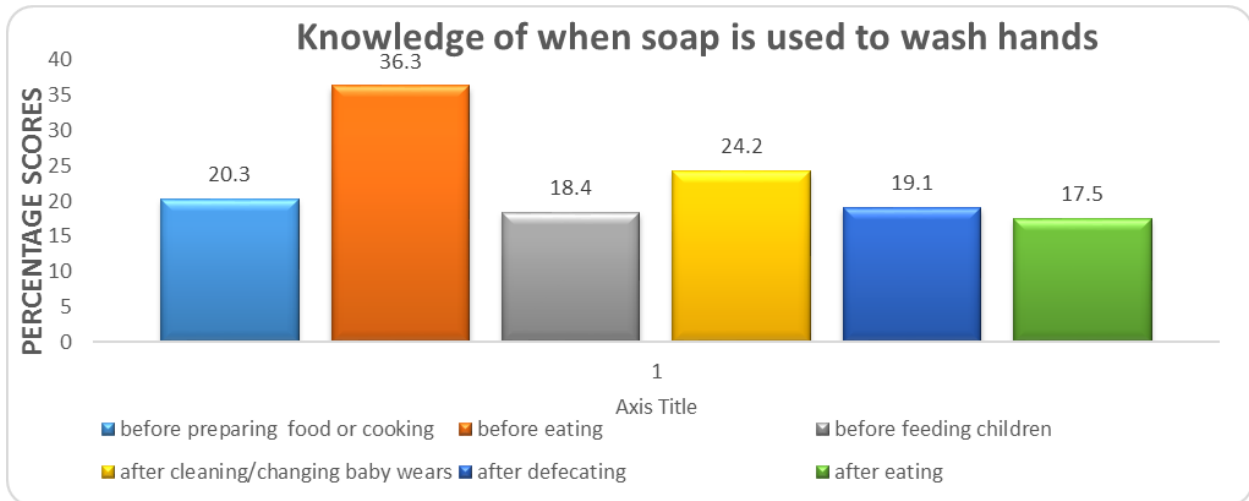


Figure 2: Knowledge of when soap is used to wash hands

Source: Field survey, 2016.

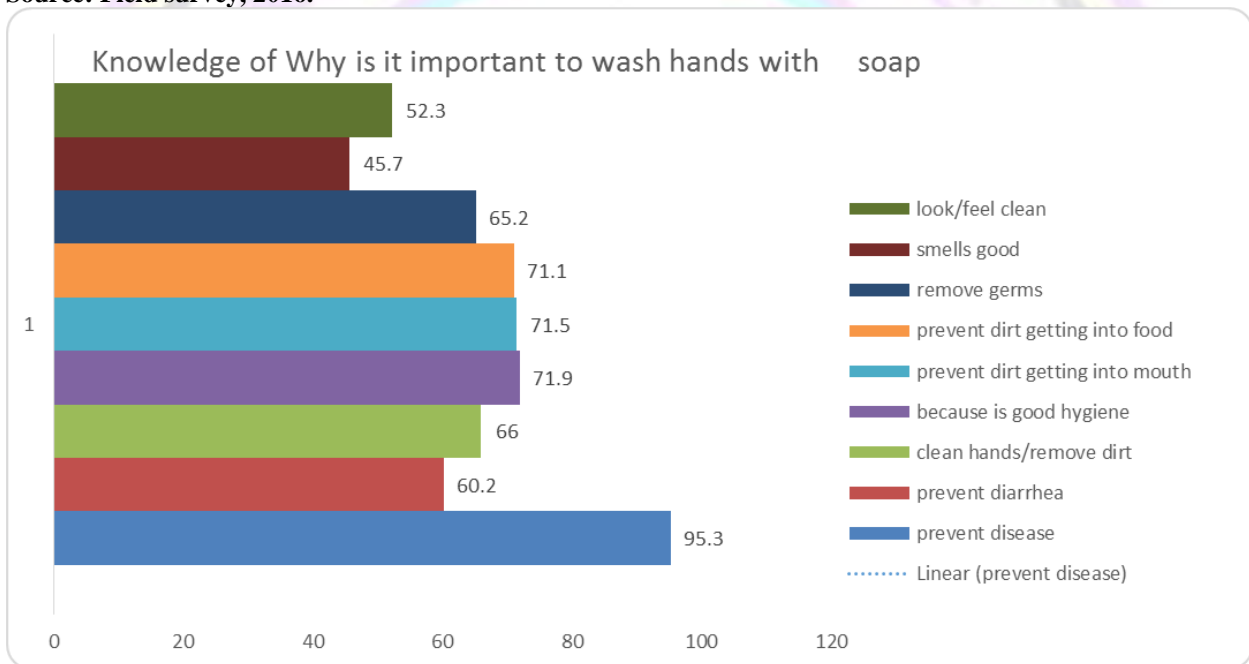


Figure 2: Knowledge of why is it important to wash hands with soap

Source: Field survey, 2016.

## REFERENCES

- Aarnisalo, K., Tallavaara, K., Wirtanen, G., Maijala, R. and Raaska, L. (2006). The hygienic working practices of maintenance personnel and equipment hygiene in the Finnish food industry. *Journal of Food Control* 17: 1001-1011.
- Abd Patah, M. O. R., Issa. Z. M. and Nor, K. M. (2009). Food safety Attitude of Culinary Arts Based Students in Public and Private Higher Learning Institutions (IPT). *International Education Studies* 2(4): 168 – 178. Available online at [www.ccsenet.org/journals.html](http://www.ccsenet.org/journals.html)
- Adejero, L. (2013). Proper Food Safety Practices and Hand Washing Prevent Food Borne Diseases. Daily Times of 3<sup>rd</sup> December, 2013. Retrieved on 3<sup>rd</sup> March, 2014 from [www.dailytimes.com.ng](http://www.dailytimes.com.ng)
- Bizatu, M and Negga B. (2010). Community based assessment on household management of waste and hygiene practices in Kersa Woreda Eastern Ethiopia. *Ethiopia Journal of Health Development*. 24(2):103 - 109.
- Cairncross, S. Hunt, C. Boisson, S. Bostoan, K. Curtis, V. Fung, I. and Schmidt, W.P. (2010) Water, sanitation and hygiene for the prevention of diarrhoea. *International Journal of Epidemiology*. 39(1): 193-205.
- Campbell, P.T. (2011). Assessing the Knowledge, Attitude and practice of Street Food Vendors in the City of Johannesburg regarding Food Hygiene and Safety. A mini-thesis submitted in partial fulfillment of the requirements for the degree of Masters in Public Health at the School of Public Health, University of the Western Cape.
- Center for Science in the Public Interest (CSPI) (2005). Global and Local Food Safety around the World. Pp 4-28 Retrieved June 10, 2113, from [www.safefoodinternational.org](http://www.safefoodinternational.org)
- Food and Agriculture Organization of the United Nations (FAO), (2001). Consultative Group on International Agricultural Research Technical Advisory Committee. Report from the Standing Committee on Priorities and Strategies (SCOPPAS): A Status Note on Food Safety retrieved 12<sup>th</sup>/09/2013 from <http://www.fao.org>:1-30
- Food Security Analysis Unit (FSAU) (2007). Knowledge, Attitude and Practice Study (KAPS): Infant and young child feeding and health seeking practices of Somalia (Report). Retrieved on 25<sup>th</sup>/8/2013 from <http://www.fsausomali.org>: 5- 45
- Gbadegesin, N. and Olorunfemi, F. (2007). Assessment of Rural Water Supply Management in Selected Rural Areas of Oyo State, Nigeria. ATPS Working Paper Series 49: 1 – 64. A publication of African Technology Policy Studies Network (ATPS), P.O. Box 10081, 00100 General Post office, Nairobi, Kenya.
- Gul, R. (2012). Hand washing practices of food handlers in the hospitality establishments of Peshawar city. *Journal of Medical Science* (Peshawar, Print), 20(1): 22-25.
- Jens, V., Monika, T., Rainer, L., Ibrahim, B., Sibel, S., Aynur, K., Alexendra, U., Farouk, M. and Herbert, P. (2009). Detection of Adenoviruses and Rotaviruses in Drinking Water Sources Used in Rural Areas of Benin, West Africa. *Applied and Environmental Microbiology*. 75 (9): 2798–2801.
- Karnali Integrated Rural Development and Research Centre (Mission East/KIRDARC) (2009). Knowledge, Attitude and Practices “Clean water, improved sanitation and hygiene promotion in rural villages of Humla and Mugu, Mid-West Nepal” ECHO/NPL/BUD/2008/01005 Final report. Pp 8 – 22.
- Liu, P. (2007). Potentially Unsafe Food Safety Behaviours Related to Gardening in Southeast Ohio. A Master Degree Thesis presented to the Faculty of the College of Health and Human Services of Ohio University: 86 – 96.
- Mohammed, S. G.S (2013). Food Safety Knowledge among Women in Selected Areas in Khartoum City. *International Journal of Science and Research (IJSR), India*, 2 (2): 519-525.
- Musa, O. I. and Akande, M. T. (2003). Food Hygiene Practices of Food Vendors in Secondary Schools in Ilorin. *The Nigerian Postgraduate Journal*, 10 (3): 192-196.
- Nee, S.O.I. and Sani, N.A. (2011). Assessment of Knowledge, Attitude and practice (KAP) Among Food Handlers at Residential Colleges and Canteen Regarding Food Safety. *Sains Malaysiana* 40 (4): 403-410
- Phaswana – Mafuya, N. and Shukla, N. (2005). Factors that could motivate people to adopt safe hygienic practices in the Eastern Cape Province, South Africa. *Africa Health Sciences*, 5 (1):21 – 28.



Rahman, M. M., Taha Arif, M., Bakar, K., and Tambi, Z. (2012): Food Safety Knowledge, Attitude and Hygiene Practices among the Street Food Vendors in Northern Kuching City, Sarawak . Borneo Science. 31: 95 - 103.

Safefood (2002). Top improper Food Handling Practices and Common Job Hazard. Retrieved May 12, 2013, from [www.foodsafety.com](http://www.foodsafety.com)

Sanlier. N. (2009). The knowledge and practice of food safety by young and adult consumers. *Journal of Food Control*. 20:538-42.

Tyabo, I.S., Ibrahim, M., Ndanista, M. A. and Umar, I.S. (2014). Assessment of participation of Rural Women in Farming Activities in Shiroro Community of Niger State, Nigeria. *International Journal of Physical and Social Sciences* 4(4): 573-586.

UNICEF/WHO (2008), A Snapshot of Drinking Water and Sanitation in Africa: A regional perspective based on new data from the WHO/UNICEF Joint Monitoring Programme for Water Supply and Sanitation retrieved 23<sup>rd</sup>/12/2014 from [www.wssinfo.org](http://www.wssinfo.org).

UNICEF (2008). Global Hand Washing Day – Planners guide. Retrieved on 8<sup>th</sup>/10/2015 from [www.unicef.org](http://www.unicef.org)

UNICEF (2010). Water, Sanitation and Hygiene. Retrieved from: <http://www.unicef.org/wes/index.html>. on 23<sup>rd</sup>/12/2014.

United Nations Educational, Scientific and Cultural Organization - World Water Assessment Programme (UNESCO-WWAP) (2003). Water for People, Water for Life: The United Nations World Water Development Report. UNESCO and Berghahn Books, Barcelona, Spain.



## FARMERS' PERCEPTION ON CLIMATE CHANGE ADAPTATION ON MAIZE PRODUCTION: A CASE STUDY OF AGAIE LGA OF NIGER STATE

Mohammed<sup>1\*</sup>, S., I. Usman<sup>2</sup>, A. A. Oke<sup>3</sup>

<sup>1</sup> Niger State Agricultural Mechanization and Development Authority, Minna, Niger State, Nigeria

<sup>2</sup> Niger State Agricultural Mechanization and Development Authority, Minna, Niger State, Nigeria

<sup>3</sup> Dept of Quantity Surveying, Federal University of Technology Minna, Niger State, Nigeria

\*Corresponding Author's E-mail: [babavadi84@gmail.com](mailto:babavadi84@gmail.com) GSM: 07039614626

### ABSTRACT

*Agriculture is one of the sectors most vulnerable to climate change impact in Africa. Perceptions of climate change and its threats to rural communities are among the major challenges faced by farmers. The study was set out to investigate and determine the impact of climate change and variability on maize production in Agaie Local Government Area of Niger State and evaluates farmer's perception and farming practices. Primary data were collected through structured questionnaire, personal oral interview and focus group discussion. The survey was carried out in 231 households from 11 districts, with 21 households selected from each district. Simple descriptive statistics involving frequency counts, mean, percentages and chi-square was used for testing research hypothesis. Findings revealed among others that maize farmers in Agaie LGA are aware of climate change with its impact to include increase in temperature and amount of rainfall, and its impacts on food production. With these impacts, they have developed coping strategies to deal with the impacts of climate change. The study revealed that socio-economic characteristics of maize farmers influenced their perception of climate change. Also, there is correlation between climate change and the production of maize in Agaie LGA such as decrease in maize production during dry season due to the effects of climate change. Based on the findings, the following recommendations among others are proffered; early warning systems and disaster risk management strategies should be established to enhance the coping capacity of local farmers, irrigation farming should be encouraged by agencies such as River Basin Development Authority.*

**KEYWORDS:** Climate change, coping strategies, maize, rainfall, temperature

### INTRODUCTION

Climate change is one of the most serious environmental threats facing mankind worldwide. Agriculture is one of the sectors most vulnerable to climate change impact in Africa (Falaki *et al.*, 2013). It affects agriculture in several ways, including its direct impact on food production. Climate change, which is attributable to the natural climate cycle and human activities, has adversely affected agricultural productivity in Africa (Ziervogel *et al.*, 2006). Impact of climate is observed more where agriculture is rain-fed and essential for the daily subsistence such as in Nigeria. Across Nigeria, millions of people are already experiencing changing seasonal patterns of rainfall and increased heat. Available evidence shows that climate change is global, likewise its impacts; but the most adverse effects will be felt mainly by developing countries, especially those in Africa, due to their low level of coping capabilities (Nwafor 2007; Jagtap 2007) such as Nigeria (Odjugo, 2010). The agricultural sector contributes some percentage of the Nigerian Gross National Product and majority of the rural populace are employed in this sector. The dominant role of agriculture makes it obvious that

even minor climate deteriorations can cause devastating socioeconomic consequences. A study in Nigeria applied the Erosion Productivity Impact Calculator (EPIC) crop model to give projections of crop yield during the 21st century. The study modeled worst case climate change scenarios for maize, sorghum, rice, millet and cassava (Adejuwon, 2006). The indications from the projections are that in general, there will be increases in crop yield across all lowland ecological zones as the climate changes during the early parts of the 21st century. However, towards the end of the century, the rate of increase will tend to slow down. This could result in lower yields in the last quarter than in the third quarter of the century. The decreases in yield could be explained in terms of the very high temperatures which lie beyond the range of tolerance for the current crop varieties and cultivars.

Nigeria's high population of over 150 million people depends primarily on their physical environment for food, livelihoods and survival. Unfortunately, Nigeria lacks the political will, financial capacity and technological resources to address the postulated negative impacts of current and predicted climate

change and has not yet fully established an institutional and legal framework, systematic approach or policies targeted at mitigating and adapting to the impacts of climate change. Given the above factors, it is clear that Nigeria's long-term development goal of poverty reduction and economic growth will be severely constrained if sufficient attention is not given to the issues of climate change in Nigeria.

Climate change has serious consequences on food security, the success of which is dependent on the age long ability of farmers to predict when to plant their crops. Unpredicted changes in the onset of rains in the last 20 to 30 years have led to situation where crops planted with the arrival of early rains get smothered in the soil by an unexpected dry spell that can follow early planting.

Perceptions of climate change and its threats to rural communities are among the major issues researched by scientists. A few studies prove that these communities are aware of change in climatic conditions and their impacts on people's livelihoods (Quang Nam People's Committee, 2008; 2009). However, it is reported that rural communities' perceptions of climate change are centered on variations in temperature and rainfall patterns (Quang Nam People's Committee, 2010) manifested as rising temperature trends and scarce rainfall (Quang Nam People's Committee, 2008). Rural communities are aware that devastating changes in their living conditions such as malnutrition, poverty, water and air contamination, increased risks of disease, floods, soil erosion and depletion of biodiversity are as a result of climate and environmental variability (Quang Nam People's Committee, 2010; Department of Agriculture and Rural Development of Quang Nam, 2009). These farmers' observed changes in rainfall and temperature patterns are supported by annotations of a drastic increase in temperatures with negative impacts on the livelihood patterns of rural communities (Department of Agriculture and Rural Development of Quang Nam, 2010). This type of understanding of climate change is crucial in planning the adaptation and mitigation measures to address the effects of increased temperature and scarce rainfall for sustainable livelihood (Quang Nam People's Committee, 2010).

The problem of this study is the need to examine the issues of climate change and increased awareness of the impact of climate change. In this regard, the study is an attempt to gain as much information as possible about the positions of rural farmers and their needs, in order to offer adaptation practices that meet these needs. The objectives of this study were to investigate impact of climate change and variability on maize production in Agaie LGA of Niger State as

well as to evaluate farmer's perception and farming practices as it relates to climate change. Two hypotheses were formulated for testing by the study:

**Ho<sub>1</sub>:** There is no significant relationship between the socio-economic characteristics of maize farmers and the level of awareness of the impact of climate change.

**Ho<sub>2</sub>:** There is no significant relationship between Climate change and maize production in Agaie LGA.

## METHODOLOGY

The study was conducted in Agaie Local Government Area of Niger State. Agaie is made up of 11 political districts which were adopted for the study. The instrument for the collection of primary data was structured questionnaire, personal oral interview and focus group discussion. The target population for the study was made up of the arable farmers in the selected districts of the LGA. The farm household survey was carried out in 231 households from the 11 districts, with 21 households selected from each district. Purposive sampling method was used for the selection of households. Series of focus group discussion and key informants' interview discussions were conducted about climate change impacts on maize production, adaptation, and mitigation strategies with members of the community and local government extension workers. Simple descriptive statistics involving frequency counts, mean and percentages was used in the analysis of the data, while chi-square was used for testing of the research hypotheses.

## RESULTS AND DISCUSSION

**Demographics of Respondents:** As presented in Table 1, majority representing 69.70% are males, while 30.30% are females which could be attributed to the fact that males are more involved in tedious work. Results further reveals that 4.76% are below 30 years, 7.79% are between 31-5yrs, 15.59% are between 36-40yrs, 20.78% are between 41-45yrs, 24.24% are between 46-50yrs and 26.84% are between 51 years and above. This implies that majority are in their active and productive years, so they could provide relevant information on climate change. Majority (57.58%) of the respondents have formal education. This implies that they could understand the issues on impact of climate change on crop production.

**Climate Change Information Channels:** Findings revealed the major channels of information through which respondents received information on climate change as majority (58.44%) of them is through radio; 22.08% through services of extension workers; 16.45 % through television; 1.73% through print media and 1.30% through agricultural shows. None



of the respondents obtained information through conferences/workshops/Seminars and Entrepreneurship Centers. This implies a lack of training programmes for rural farmers in the study area.

**Perception on Climate Change:** The perception of farmers on climate change in the study area shown in Table 2 revealed that 45.45% perceive the impact of climate change to reflect delayed rainfall, 33.33% as unusual heavy rainfall, 14.72 % as higher temperature, 6.50% indicated unusual early rains that are followed by weeks of dryness while, 2.60% perceive it as reoccurring flood with devastating impact. Result from this study is similar to Farauta *et al.* (2011) and Ayanwuyi *et al.* (2010) who reported that delayed rainfall, intense rainfall, higher temperature and early rains followed by weeks of dryness as perception of climate change by farmers.

**Effect of Climate Change on Maize Production:** Findings revealed that majority (31.60%) of the respondents are of the opinion that climate change has caused increase in incidences of flood during raining season, 26.41% stated that it has caused increased incidences of prolonged dry season, 21.21% indicated shortage of maize during dry season, 18.62% indicated increase in cost of maize, and 2.16% indicated crop infestation and diseases. This implies that the effects of climate change is seen in problems of flood, drought and prolonged dry seasons which has resulted to shortage of maize grains in the dry season and increase its cost. The study further revealed that the infestation of maize crop caused shortage in production and subsequent high cost.

**Coping Strategies:** The findings of the study as shown in Table 3 revealed that the farmers employed multiple coping strategies in response to climate change. The major strategies include planting of different crops (60.17%), planting of different varieties (75.32%), mulching (54.55%), changing cropping pattern (60.17%), usage of chemical fertilizers and pesticides (68.40%), and application of improved technologies (89.61%). Another strategy used includes shading and shelter (46.75%). This implies that the coping strategies were used complementarily and therefore justifies the review of Kurukulasuriya and Mendelsolhn (2006) which stated that adequate adaptation strategies significantly reduce the effects of climate change on crop production. The results also agree with findings of Molua (2008); Rudolf and Hermann(2009); and Apata *et al.* (2009) who stated that the major strategies for the reduction of the impacts of change is the diversification of production, livelihood systems like soil and water management measures, as

well as plant protection measures that varied to maintain adequate crop yields.

**Hypotheses Testing:** The first hypothesis  $H_{01}$  stated that 'there is no significant relationship between the socio-economic characteristics of maize farmers and the level of awareness of the impact of climate change'. Findings from Table 4 revealed the relationship between the socio-economic characteristics of maize farmers and their level of awareness of the impact of climate change. The result revealed that  $X^2_{cal}$  (914.51) is greater than the  $X^2_{Tab}$  (46.19) which implies that there is significant relationship between the socio-economic characteristics of maize farmers and their level of awareness of the impact of climate change. Furthermore, the null hypothesis  $H_{01}$  is rejected and alternative hypothesis is accepted.

Findings from Table 5 revealed the relationship between Climate change and maize production in Agaie LGA. The result revealed that  $X^2_{cal}$  (93.49) is greater than the  $X^2_{Tab}$  (26.30) which implies that there is significant relationship between climate change and maize production in Agaie LGA. The null hypothesis  $H_{02}$  is therefore rejected.

## CONCLUSION AND RECOMMENDATIONS

The study concludes that maize farmers in Agaie LGA have awareness of climate change with their perception of some of its effects as increase in temperature and amount of rainfall, as well as its impacts on food production. With these, they have developed strategies to cope with the impacts of climate change. The socio-economic characteristics of maize farmers such as age, sex, and educational status among others influenced their perception of climate change. Also, there is correlation between climate change and the production of maize in Agaie LGA such as decrease in maize production during dry season due to the effects of climate change.

The following recommendations are proffered based on the findings of the study:

1. Farmers in Agaie LGA should be encouraged to have alternative sources of income, to enable diversification of their economy and cushion effect during times of low crop yield.
2. Irrigation farming should be encouraged by agencies such as River Basin Development Authority.
3. Policies should be designed to enhance coping strategies of farmers at local levels through the establishment of early warning systems and disaster risk management strategies.
4. Government policies and researches geared towards addressing the impact of climate change should consider socio-economic characteristics of farmers.

5. Effective channels of information dissemination should be introduced to farmers for effective information dissemination.





Table 1: Demographic characteristics of respondents

Category	Options	Frequency	Percentage (%)
Gender	Male	161	69.70
	Female	70	30.30
Age	Less than 30yrs	11	4.76
	31-35yrs	18	7.79
	36-40yrs	36	15.59
	41-45yrs	48	20.78
	46-50yrs	56	24.24
	51 and above years	62	26.84
Highest Qualification	Uneducated	98	42.42
	Primary	31	13.42
	Secondary	72	31.17
	Tertiary	20	8.66
	Others (Quranic, Adult education, etc.)	10	4.33

Source: Author's Field Work (2017)

Table 2: Perception of respondents on climate change in Agaie LGA

Perception	Frequency	Percentage
Delayed Rainfall	102	45.16
Unusual Heavy Rainfall	74	32.03
Higher Temperature	34	14.72
Unusual early rains followed by weeks of dryness	15	6.50
Recurring flood with devastating impact	6	2.60
Undefined seasons	0	0
Fast water evaporation from the ground	0	0
Later fruiting of tree crops	0	0
Longer days than nights	0	0

Source: Author's Field Work (2017)

Table 3: Coping strategies to climate change by farmers in Agaie LGA

Coping Strategies	Yes		No	
	Frequency	%	Frequency	%
Shading and Shelter	108	46.75	123	53.25
Planting of different crops	139	60.17	92	39.83
Planting of different varieties	174	75.32	57	24.68
Mulching	126	54.55	105	45.45
Changing cropping pattern	139	60.17	92	39.83
Usage of chemical fertilizers and Pesticides	158	68.40	73	31.60
Application of improved technologies	207	89.61	61	10.39

Source: Author's Field Work (2017)

Table 4: Maize farmers' socio-economic characteristics and level of climate change impact awareness in Agaie LGA

Perception	SA	A	U	SD	D	Total
Delayed Rainfall	102	84	34	5	6	231
Unusual Heavy Rainfall	79	131	17	3	1	231
Higher Temperature	97	103	22	6	3	231
Unusual early rains that are followed by weeks of dryness	142	78	7	2	2	231
Recurring flood with devastating impact	88	103	25	7	8	231
Undefined seasons	0	41	89	76	25	231
Fast water evaporation from the ground	23	71	52	40	45	231
Later fruiting of tree crops	47	93	29	21	41	231
Longer days than nights	17	31	44	72	67	231
Total	595	735	319	232	198	2079
<i>Expected value</i>	<i>66.11</i>	<i>81.67</i>	<i>35.44</i>	<i>25.78</i>	<i>22.0</i>	

Source: Author's Field Work (2017)

SA= Strongly Agree; A=Agree; U=Undecided; SD=Strongly Disagree; D=Disagree

DF = 32, level of significance = 0.05,  $X^2_{cal} = 914.51$ ,  $X^2_{Tab} = 46.19$

**H<sub>02</sub>:** There is no significant relationship between Climate change and maize production in Agaie LGA.

Table 5: Relationship between climate change and maize production in Agaie LGA

Perception	SA	A	U	SD	D	Total
Increase in cost of maize	113	83	20	7	8	231
Shortage of maize during dry season	139	66	19	6	1	231
Increase incidences of flood during raining season	157	56	11	0	7	231
Crop infestation and diseases	79	117	20	8	7	231
Increase incidences of drought during dry season	87	123	14	3	4	231
Total	575	445	84	24	27	1155
<i>Expected value</i>	<i>115</i>	<i>89</i>	<i>16.8</i>	<i>4.8</i>	<i>5.4</i>	

Source: Author's Field Work (2017)

DF = 16, level of significance = 0.05,  $X^2_{cal} = 93.49$ ,  $X^2_{Tab} = 26.30$

## REFERENCES

- Adejuwon J. O. (2006). Food crop production in Nigeria. II :Potential effects of climate change. *Climate Research*, 32(1), 229-245.
- Apata T. G., Samuel, K. D. & Adeola, A. O. (2009). Analysis of Climate change perception and adaptation among arable food crop farmers in South Western Nigeria paper presented at the conference of International Association of Agricultural Economics pp. 2-9.
- Ayanwuyi, S., Kuponiyi, E., Ogunlade, F.A. & Oyetero, J.O. (2010). Farmers perception of impact of climate changes on food crop production in Ogbomosho Agricultural Zone of Oyo State, Nigeria. *Global Journal of Human Social Science*, 10(7), 33-39.
- Department of Agriculture and Rural Development of Quang Nam (2009). Agricultural statistics 2003-2008 and plan to 2020 in Quang Nam.
- Department of Agriculture and Rural Development of Quang Nam (2010). Report on the agricultural production (2000 to 2010), The archival document.
- Falaki, A. A., Akangbe, A. A. & Ayinde, O. E. (2013). Analysis of climate change and rural farmers' perception in North Central Nigeria. *Journal of Human Ecology*, 43(1), 133-140.
- Farauta, B.K., Egbule, C.L., Idrisa, Y.L. & Agu, V.C. (2011). Farmers' Perceptions of Climate Change and Adaptation Strategies in Northern Nigeria: An Empirical Assessment. *African Technology Policy Studies Network*, Research Paper No. 15.
- Jagtap, S. (2007). Managing vulnerability to extreme weather and climate events: Implications for agriculture and food security in Africa. *Proceedings of the International Conference on Climate Change and Economic Sustainability* held at Nnamdi Azikiwe University, Enugu, Nigeria. 12-14 June 2007.
- Kurukulasuriya, P. & Mendelsohn, R. (2006). Crop Selection: Adapting to Climate Change in Africa. CEEPA Discussion Paper No. 26. Pretoria, South Africa: Centre for Environmental Economics and Policy in Africa.
- Molua, E. L. (2008). Turning up the heat on African Agriculture: The impact of climate change on Cameroon's agriculture. *African Journal of Agriculture and Resource Economics*, 2(1), 45-64.
- Nwafor, J. C. (2007). Global climate change: The driver of multiple causes of flood intensity in Sub-Saharan Africa. Paper presented at the *International Conference on Climate Change and Economic Sustainability* held at Nnamdi Azikiwe University, Enugu, Nigeria, 12-14 June 2007.
- Odjugo, P. A. O. (2010). General overview of climate change impacts in Nigeria. *Journal of Human Ecology*, 29(1), 47-55.
- Quang Nam People's Committee (2008). Plan aimed at national strategies for natural disaster prevention, control and decrease by 2020 in Quang Nam.
- Quang Nam People's Committee (2009). Summary report on annual flood prevention from 1997 to 2009.
- Quang Nam People's Committee (2010). Implementation plan of the project "Raising community awareness of and managing natural disaster risks based on communities in Quang Nam by 2020".
- Rudolf, W. & Hermann, W. (2009). *Climate risk and farming Systems in Rural Cameroon*. Institute of Development and Agricultural Economics. Germany: University of Hannover pp. 21-24.
- Ziervogel, G., Nyong, A., Osman, B. Conde, C., Cortes, S. & Dowing, T. (2006). Climate variability and change: implications for household food security. Assessments of Impacts and Adaptations to Climate Change (AIACC) Working Paper No. 20, January 2006. The AIACC Project Office, International START Secretariat, Washington DC, USA.



## COMPARATIVE EVALUATION OF THE EFFICIENCY OF TRADITIONAL AND MODIFIED MALIAN TRAPS IN CAPTURE FISHERIES

J.Yusuf <sup>1\*</sup>, S.L. Lamai <sup>2</sup>,

Federal University of Technology Minna, Niger State

<sup>2</sup> Federal University of Technology Minna, Niger State

\*Corresponding Author's E-mail: [j.yusuf@futminna.edu.ng](mailto:j.yusuf@futminna.edu.ng) GSM: [08136161501](tel:08136161501)

### ABSTRACT

An evaluation to comparatively determine the efficiency of a modified and traditional Malian traps in capture fisheries was carried out in Dan-Zaria Dam, Niger State. The traps were designed and constructed with the following wooden frame dimensions:- the traditional trap which was cone shaped, had a base diameter of 135cm, middle diameter of 115cm and terminal diameter of 77cm and height of 75cm; while that of the modified trap which was rectangular-shaped, had a base length of 100cm, width of 50cm and height of 40cm both were enclosed in a netting materials of 3.75cm mesh size. The traditional traps had two non-return valve while the modified had three non-return valves with recovery opening at top of each. They were both designed and constructed simultaneously at site. The traps were both introduced into the water and set unbaited in pairs at three different location in the Dam. To aid both stability and permanence, stone weights and wet grass were placed on top of the traps and stick pegged closed to them for easy identification during monitoring visits. Collection of catch was carried out twice weekly for a period of six weeks. At each visit, the location of traps were alter to create wider sampling area. The catches were each brought into the laboratory for analysis. A total of twelve visits were made and analysis of catches showed that a total of 146 fishes and turtles were caught by both traps. The comparative catches analysis of the total showed that traditional Malian trap caught 82 fishes only, comprising of 45 *Clarias gariepinus*, 25 *Clarias anguillaries* and 12 *Oreochromis niloticus* representing 54.87%, 30.48%, and 14.63% respectively; While the modified traps caught 50 fishes, comprising 28 *Clarias gariepinus*, 15 *Clarias anguillaris* and 7 *Oreochromis niloticus* representing 43.73%, 23.43% and 10.93% respectively and 14 turtles (*Testudinidae*). The species diversity index for the traditional and modified Malian traps were 0.023 and 0.027 respectively. Based on the results, it was concluded that while the traditional traps had higher caught than modified traps there was no significant difference ( $P>0.05$ ) between the two, hence in terms of catch efficiency the traditional trap is more efficient than the modified trap, however, modified trap had the advantage of trapping other aquatic living resources (Turtles) than fish.

**KEYWORDS:** Traditional Malian Trap, Dan-Zaria Dam, Modified malian Trap, Turtles

### INTRODUCTION

The fishing gear and techniques used in artisanal fisheries, such as in the inland freshwater of Nigeria, are known to be labour intensive with low catch per unit effort and low income to the fishermen. Therefore, improvement on the fishing gears, particularly the traditional ones, or development of new and more efficient gear, is highly required. Therefore, the improvement or development of a new gear should be made in such a way that the materials are locally available to the artisanal fishermen, the design and

construction should be easy and cheap. It should also be More efficient and, at the same time, ensure conservation of fisheries resources unlike the conventional ones being used (Agbelege and Ipinjolu 2004)

Fishing gear generally undergoes a lot of modifications and fisher improvements in consonance with advances in modern technology, The technology of fish exploitation under small-scale fisheries, as in Nigerian inland fisheries, is characterised by the use of simple fishing gears and techniques. The designs, types and mode of



operations of the traditional and modern fishing gears used in inland and coastal waters in Nigeria have been fairly described. Agbelege and Ipinjolu (2004) Malian trap is one of the most widely used, in combination with other traditional and modern fishing gears. Agbelege and Ipinjolu (2001) reported in their studies that 70 to 100 % of the fishermen sampled in Lake Chad, used Malian trap in combination with other traps. Also a survey conducted along River Rima in North Western Nigeria also showed that 30-90% and 30 – 50 % of the fishermen used Malian and Ndurutu traps, Respectively.

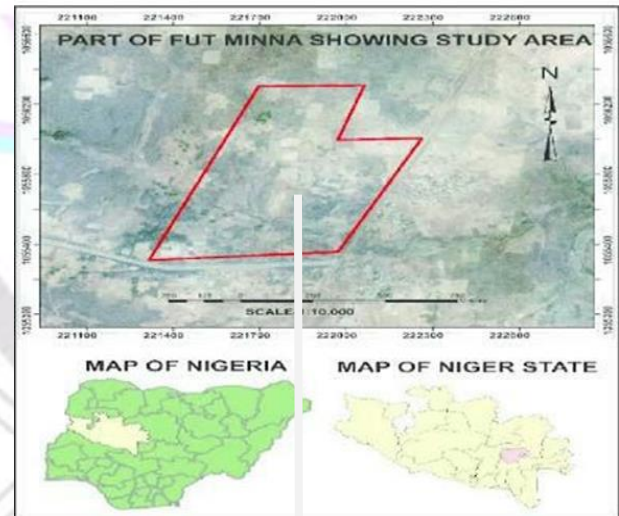
The Malian trap was introduced to Kainji Lake area by immigrating fishers from the Republic of Mali (Ipinjolu *et al.*, 2004). The trap is known to be gaining ground among the artisanal fisher folks of the Kainji Lake basin. Popularly known as gura in the area, it is a wicker trap essentially made of wood-cane either from 2cm diameter branches of a tree locally named taura or a shrub identified as the giant sensitive plant, *Mimosa pigra* and *Mimosa invisa* (Akobundu and Agyakwa, 1987; du Feu, 1993 and Ahmed *et al.*, 2004). reported that the frame of the trap is covered with 25.4mm mesh polyamide netting material with mean height of 0.71m (range 0.36-1.37m) and the base width mean of 0.52m. The diameter of the fish entry holes at the base is 0.10m on the average.

(Lamai and Kolo, 2003) studied biodiversity and abundance of fish and plankton using cast net, fleet of gill net of various sizes from one inch to seven inches in Dan-zaria Dam for a period of one year and caught a total of 2,010 fishes. The species caught were *Clarias gariepinus*, *Oreochromis niloticus*, *Tillapia zilli*, *Aleste nurse* and *Lebeo senegalensis*

Ago *et al.* (2012) studied the comparative performance of the newly developed Malian trap and the traditional Malian trap in lake

kainji and caught a total of 1,885 fishes belonging to 19 species of 10 families with a total weight of 72,235 grams. During dry season a total of 203 fish weighing 4, 685 grams were caught with the PVC trap while the Malian trap caught 868 fish, weighing 18, 335 grams.

## METHODOLOGY



Map of the Study Area

Wooden stick of giant sensitive plant (*Mimosa pigra*) was used as wooden frame for the construction. The diameters of the stick were 3cm to 4cm respectively. The

sticks were cut and dressed with the aid of cutlass. They were soaked in water for 2 weeks for its offensive odour to escaped. Thereafter, the sticks were dried. The dried sticks were bent to form round shape of different diameters 135cm, 115 cm and 77cm respectively, and tied strongly with rope Number 9, to prevent loosening. 6 wooden frames of 75cm height were mounted and tied on the round bottom. The same procedure was repeated for the middle and the tops. Thereafter, the structure was enclosed in polyamide netting material of 3.75cm mesh size. Space for non-return valves were carved out and the non-return valves were finally fixed. All in all 3 traditional Malian traps were constructed.

**2.2.2 Modified (Semi-circular) Malian trap**  
Similarly too the giant sensitive plant (*Mimosa pigra*) was also used for the construction of modified Malian trap. The wooden sticks from the giant sensitive plant passed through the same process as explained in (2.1.2). 110cm length, and 64cm width of the wooden stick were tied together to formed rectangular shape. This was followed with the mounting of bent wooden frame of 46cm height. The frame was supported with straight wooden sticks strongly

tied together. Thereafter the structure was also enclosed in polyamide netting material of 3.75cm mesh size. Space for non-return valves were carved out and the non-return valve were finally fixed. All in all, three modified Malian traps were constructed.

### 2.3 Trap setting procedure

After construction, the traps were set in Dan-zaria Dam. 12 fishing visits were conducted in different locations and depth of the water at different times. Both the traditional and modified traps were set in pairs in three different locations on every fishing visit. They were set un-baited with a stone and wet grasses placed on the top for stability of the traps. Sticks pegged close to

the trap for easy identification during monitoring visits.

### 2.4 Inspection and Data collection on trapped fishes and turtles

The trap were inspected for collection of trapped fishes and tortoise twice a week for six weeks. At each visit the traps were lifted out of water and the trapped fishes and tortoise were retrieved. They were then collected into a cooler jug and transported to the Laboratory for analysis by measurement of length, weight, and identification to species level.

A 30cm Ruler was used to measured the total length of each fish while monograph of Olaosebikan and Raji (1998) was used to identify the species caught. Citizen sensitive weighing balance was also used to determine weight of the fish and tortoise

### Statistical analysis

Data obtained were subjected to t- test, in order to test for the significant difference between efficiency of the traditional with modified Malian traps. Also, species diversity index was calculated using the formula below-

### Determination of Species Diversity Index

The species diversity index was calculated using Shanon-Wiener index 1963:

$$H = - \sum_{i=1}^n \left( \frac{n_i}{N} \left[ \log_2 \left( \frac{n_i}{N} \right) \right] \right)$$

Where:

H = Shannon-Wiener index of diversity

$n_i$  = Total No. of individuals of a species

N = Total No. of individuals of all species

Species diversity index (SDI) =

$\frac{\text{Total number of individual of species}}{\text{Total numbers of individual of all species}}$

## RESULTS AND DISCUSSIONS



Both the traditional and modified Malian traps caught 3 species of fish. The species were *Clarias gariepinus*, *Clarias anguillaries* and *Oreochromis niloticus*. Only the modified Malian trap caught 14 turtles (*Testudinidae*). The total species, numbers and percentage of organism caught by the traps is shown in Table 1. A total of 82 fishes were caught with the traditional Malian trap, these include *Clarias gariepinus*, *Clarias anguillaries* and *Oreochromis niloticus* accounting for 45, 25 and 12 with a percentage of 54.87%, 30.48%, and 14.63% respectively. While a total of 64 fishes and turtles were caught with modified Malian trap. 14 accounted for turtles with 21.87% while *Clarias gariepinus*, *Clarias anguillaries* and *Oreochromis niloticus* accounted for 28, 15, 7 with percentage of 43.73%, 23.43%, and 10.93% respectively. Species diversity index for the traditional and modified Malian trap were 0.023 and 0.027 respectively. The mean total for the

species of fish and tortoise for the traditional and modified Malian traps were (Mean 27.3) and (Mean 21.2) respectively. The statistical analysis carried out for the species caught using t-test showed no significant difference ( $P>0.05$ )

Table 2 showed the total weight of the fishes and turtles caught. A total of 146 fishes and tortoise were caught with total weight of 29,756.7gram (29.7 kg). 14,449.7gram (14.4 kg) of the weight accounted for traditional Malian trap, while 15,307gram (15.3 kg) was the total weight of fishes and turtles caught with modified Malian trap. 10,160 gram (10.1 kg) and 5,147 gram(5.1 kg) accounted for weight of fish and turtles respectively. Statistical analysis for the weight of fish and turtles caught with modified and traditional Malian trap using independent t- test showed no significant difference ( $P>0.05$ )

Table 4. 1: Species of organism caught with the traditional and modified Malian traps

Species	Traditional Malian				Modified Malian trap				
	Number	Mean	%	Mean %	Number	Mean	%	Mean %	
<i>Turtles</i>	-	0	-	0	14	4.6	21.8	7	
<i>Clarias gariepinus</i>	45	15	54.87	9.7	28	9.3	43.7	15.7	
<i>Clarias anguillaries</i>	25	8.3	30.48	10.1	15	5	23.4	7.8	
<i>Oreochromis niloticus</i>	12	4	14.63	4.8	7	2.3	10.93	3.6	
Total	82	27.3	100	24.6	64	21.2	100	34.1	
Diversity index	20.5				16				

The mean values are the replicate value for the catch. Traditional Malian traps 3 replicate.  
Modified Malian traps. 3 replicate

Table 2: Biomass of fish and turtles caught with the Traditional and Modified Malian traps.

	Traditional Malian Trap			Modified Malian Trap		
	Weight(g)	Mean	%	Weight(g)	Mean	%
1	4,773.7	1591.2	33.03	-	0	-
2	2,544.7	973.8	17.61	2,767	922.3	18.07
3	-	0	-	766.8	255.5	5.00
4	2,921.4	973	20.21	5,607	1869	36.63
5	2,193.3	731.1	15.17	215	71.6	1.40
6	228.4	76.13	1.58	97.2	32.4	0.63
7	282.9	94.3	1.95	-	0	-
8	355	118.3	2.45	665.2	221.7	4.34
9	54.1	18	0.37	1,366	455.3	8.92
10	395.5	131.8	2.73	1,460	486.3	9.53
11	429.2	214.6	2.97	1,731	577	11.30
12N	271.5	90.5	1.87	630.3	210.1	4.11
Total	14,449.7		100		5101.2	100
Total Average mean	5012.7		115,307		425.1	



## DISCUSSIONS

Different aquatic organisms were caught with traditional and modified Malian traps. Traditional Malian trap caught only fish, while modified Malian trap caught both fish and tortoise. The fish caught with the 2 traps differ in shape, feeding habit, and ecological niches Holden and Reed 1972. The fish comprised of pelagic fish (*Tillapia*) and mid water fish (*Clarias*). The differences in organism caught could be attributed to the feeding habit of the tortoise and absolute immersion of the modified Malian trap when set for fishing at the lithoral part of the water. Because tortoise feed on plants, insect, worm and snail at the lithoral part of the water. This is in consonant with what Muoneke *et al.* 1993 reported that the capture efficiency of passive gear depends on a variety of factors including shape of the gear, species, habitat, size, behaviour and gear attributes. Neither fish nor tortoise were caught with the modified Malian trap during the first visits while traditional Malian trap caught a total of 24 fishes. The reason for this could be as a result of the structure of the modified trap which appeared unfamiliar to the fish and tortoise. However, subsequent visit yielded record of catch after gradual familiarity of the fish to the modified trap. Ahmed *et al.* (2010) studied the effect of 3 fishing baits on catch composition of traditional Malian trap in Kainji Lake and caught a total of 218 fish, weighing 8.66 kg. Also Ago *et al.*, 2012 caught 203 fish weighing 18.5kg during dry season in Kainji Lake using PVC Malian trap. Agbelege *et al.*, 2004 and Ogunfowora *et al.*, 2011, all reported fish in their catch when compared to the catch in this study. None have reported tortoise or other aquatic organism in their catch. Though catch of several species such as *Lates niloticus*, *Hemichromis fasciatus*, *Labeo coubei*, *Chrisichthys nigrodigitatus*, *Tillapia zilli*, *Oreochromis niloticus*, *Bagrus bayad*,

*Clarias gariepinus*, *Clarias anguillaries* and *Malapterus electricus* were reported in their studies. The differences in species, numbers and their weight with this study could be attributed to location, duration of studies and season of the year. The bait employed in their studies could also be one of the contributing factors. As this study was conducted during the flood season and over a short period of time, precisely September to October. Also, no bait was employed in the study.

The large number of *Clarias gariepinus*, *Clarias anguillaries* and *Oreochromis niloticus* caught with traditional and modified Malian in this study is an indication of their dominance over others species in Dan-zaria dam. This differed with what Lamai and Kolo 2003 reported in their studied of biodiversity and abundance of fish and plankton in Dan-zaria Dam. Where *Tillapia zilli* was among the dominance species in their catches. Also, *Lebeo senegalensis* and *Alestes nurse* were among the species reported in their catches. In comparison with the result of this study, it indicates either rapid decline in population or seasonal fluctuation of these species (*Lebeo senegalensis* and *Alestes nurse*) since non of these 2 species were caught during this study.

Higher numbers of fish were recorded from Traditional Malian trap while higher biomass of fish and turtles were recorded from modified Malian trap as shown in (Table 2)

T-test statistical analysis for the numbers of fish and tortoise caught with the traps showed no significant difference ( $P > 0.05$ ). No significant difference ( $P > 0.05$ ) was also observed in biomass of fish and tortoise caught with traditional and modified Malian traps. Higher species diversity index of 0.027 was calculated for the traditional Malian trap as compared to the modified one of 0.023

The mean total for the species calculated were 27.3 and 21.2 for the traditional and modified Malian traps respectively.

## CONCLUSION AND RECOMMENDATIONS

Modified Malian trap was constructed in this work to determine increase in catch efficiency of fish in capture fisheries and to overcome the problem of poaching and stealing of traditional Malian trap due to its protrusion when set by the fishermen for fishing in Nigeria inland water bodies. The modified trap can be set with complete immersion at the lithoral part of water. The fishing visits conducted proved both traps in trapping similar species of fish of different size, and weight in Dan-zaria Dam. The species caught were (*Clarias gariepinus*, *Clarias anguillaries* and *Oreochromis niloticus*). Based on the result of species caught, it can be deduced that there is a decline or that some species like *Alestes nurse*, *Tillapia zilli* and *Lebeo senegalensis* which were earlier reported to be present in the Dam could not be trapped due to seasonal fluctuation. Only the modified trap caught turtles. Therefore, in terms of comparative efficiency between the traps, the Modified Malian trap proved to be efficient in trapping both fish and reptile. This indicates that a modified Malian trap of this type can be used efficiently to trap reptiles like turtle either for food or research purpose.

## RECOMMENDATIONS

Based on the result, the modified Malian trap can be recommended to fishermen who have the intention of not only trapping fish but also turtles. The trap can be set with absolute immersion in the lithoral part of the water body to overcome poaching.

More studies should be carried out on the appropriate mesh size and number of non-return valves that will be efficient as this study is a preliminary research based on comparative efficiency between traditional and modified Malian trap in capture fisheries.

Aside the dominance species discovered in this study, additional species of fish should be stocked in the Dam. During the course of the fishing visits there was an incident of poaching and stolen of one traditional Malian trap which was later recovered with the intervention of the University security. It is on the basis of this fact that the Department should further explore a means of securing the Dam in order to curb these challenges occasioned by some of the villagers dwelling around the vicinity of the Dam. The study was conducted during the flood season over a short time frame, September to October to be precise. Subsequent study on the modified Malian trap should be conducted over a longer period of time that will cover both wet and dry seasons.

## REFERENCES

- Agbelege, O.O. and J.K. Ipinjolu (2001). An assessment of the exploitation and management techniques of the fishery resources in the Nigerian portion of Lake Chad. *Journal of Arid Zone Fisheries, Vol. 1: 137p.*
- Agbelege O. O., J. K. Ipinjolu and W. A. Hassan. 2004. Evaluation of a new fishing pot trap (Lege) in River Rima, North Western Nigeria. In: P. A.
- Ago N.D, J. K. Balogun J.K., Auta and Ogunfowora O.O (2012) Comparative performance of Newly Developed Fish trap and the Malian trap in Kainji Lake, Nigeria. Vol 7(6)
- Ahmed Y. B., A. B. Adimula and E. F. Agbontaele 2004. Study on the Effects of three Fishing Baits on the Catch Composition of Malian Traps in Lake Kainji, Nigeria. In:
- Akobundu I.O. and C.W. Agyakwa. 1987. A handbook of West African weeds. IITA, Ibadan, Nigeria. pp. 312-317. Barbour M. G., Craig R. B., Drysolale F. R. and Ghiselen
- Du Feu T.A. 1993. Fishing gear survey of Kainji Lake, Nigeria, West Africa, September. Unpublished report. Nigerian - German (GTZ) Kainji Lake Fisheries Promotion Project. p. 24.
- Holden. M. and W Reed 1972 West African Freshwater Fishes West African Nature Handbooks. Longman\_ 68p.
- Ipinjolu J.K. Agbelege O.O and Hassan W.A 2004 exploratory survey of malian and N'durutut traps in river rima, north Western Nigeria. In: P. A. Araoye. *Proceedings of the 19th Annual Conference of the Fisheries Society of Nigeria (FISON), Ilorin 29th November - 3rd December 2004. pp.341-348.*
- Lamai S.L and Kolo R.J 2003 Biodiversity and abundance of and plankton of Dan-zaria Dam. *Journal of Aquatic sciences Niger State, Nigeria Volume 18. (2)*
- Muoneke et al.. 1993. Comparative capture efficiencies of frame and hoop nets for white crappie (*Pomoxis annularis Rafinesque*). *Fisheries Resources*. 18: 231-240. ,222:51p
- Ogunfowora, O. O.; Yem, I. Y.; Ojo, S.O.; Ogunfowora, S.A 2011 The performance of Malian trap using four bait types, Lake Kainji, Nigeria. Sciences, University of Florida.
- Olaosebikan B. D. and A. Raji. 2004. Field Guide to Nigerian Freshwater Fishes. 2nd Edition. Federal College of Freshwater Fisheries Technology, New Bussa, Nigeria. p. 111.
- Reed, W., Burchard, J., Hopson, A. J., Jennes, J. and Yaro, I. (1967). Fish and Fisheries of Northern Nigeria. Ministry of Agriculture, Northern Nigeria, Zaira.
- Shannon, C.E. and W. Weaver, 1963. The Mathematical Theory of Communication. University of Illinois Press, Urbana, pp: 36
- SPSS, (2007). Statistical Package for the Social Sciences. SPSS for Windows. Release Version 16.
- Umar, K.A. (2001) Studies on the Types and Catch Efficiency of Pot Fishing Traps in Sokoto



## MOLECULAR IDENTIFICATION OF VIRUSES INFECTING CASSAVA IN SELECTED LOCAL GOVERNMENT AREAS OF OYO STATE, NIGERIA

Salaudeen\*, M. T., Adeleke, I. A., Adama, C. J. and Muhammad, A. N.

Department of Crop Production, School of Agriculture and Agricultural Technology, Federal University of Technology, P. M. B. 65, Minna, Niger State, Nigeria

\*Corresponding Author's E-mail: [mtsalaudeen.fut@gmail.com](mailto:mtsalaudeen.fut@gmail.com); GSM 08063330183

### ABSTRACT

*Cassava is one of the most important food crops in Nigeria in terms of production and utilization. However, low productivity of the crop is associated with major virus diseases. A survey was conducted to identify the viruses infesting cassava in five Local Government Areas (LGAs) of Oyo State Nigeria. Twenty-five cassava fields were surveyed in February 2018 during which 75 symptomatic cassava leaves were collected. Total nucleic acid extraction of the samples was done using Cetyl Trimethyl Ammonium Bromide (CTAB) extraction protocol followed by multiplex Polymerase Chain Reaction (PCR) for African cassava mosaic virus (ACMV) and East African cassava mosaic virus (EACMV) identification. Symptoms observed included leaf curling, mosaic and “candle-like” sticks. Both ACMV and EACMV were detected in single infections at Akinyele LGA, whereas only ACMV was found in Atiba, Egbeda and Ikereku LGAs. Conversely, none of the samples from Afijio LGA tested positive for both viruses. Of the total leaf samples, 22.7 % were positive for ACMV, whereas 2.7 % tested positive for EACMV. The highest ACMV disease incidence was encountered in Akinyele (6.7 %), Egbeda (6.7 %) and Ikereku (6.7 %) LGAs while 2.7 % of the total samples were positive for ACMV in Atiba LGA. The low incidences of ACMV and EACMV implied that cassava production is not threatened by these viruses in the surveyed areas. However, adoption of resistant cassava cultivars should be intensified as a precautionary measure.*

**KEYWORDS:** African cassava mosaic virus, Disease incidence, East African cassava mosaic virus, Polymerase chain reaction, Survey

### INTRODUCTION

Cassava (*Manihot esculenta* Crantz) originated in South America but is an important root crop in sub-Saharan Africa. In Nigeria, it is grown in all agro-ecological zones and plays a vital role towards food security. In 2016, about 277.1 million tonnes of cassava were produced worldwide (FAO, 2016). In Africa, its production stood at 157.3 million tonnes. The top ten cassava producing countries were Nigeria (57.1 million tonnes), Thailand (31.2 million tonnes), Brazil (21.1 million tonnes), Indonesia (20.7 million tonnes), Ghana (17.8 million tonnes), Democratic Republic of Congo (14.7 million tonnes), Viet Nam (11 million tonnes), Cambodia (10.2 million tonnes), Angola (9.9 million tonnes) and Mozambique (9.1 million tonnes). Besides food for human consumption, cassava is used for several other domestic and industrial purposes in sub-Saharan Africa. It can be processed into *gari*, *lafun*, starch, bread or boiled with beans (Samura *et al.*, 2014). Low cassava yield has been attributed to several factors. It is mostly cultivated by smallholder resource poor farmers. In addition, insect pests and diseases are responsible for low output. In addition to African cassava mosaic virus (ACMV), several species of *Begomovirus* viruses inducing severe cassava yield losses have been confirmed. These are

South African cassava mosaic virus (SACMV), East African cassava mosaic virus (EACMV), East African cassava mosaic Cameroon virus (EACMCV), East African cassava mosaic Zanzibar virus (EACMZV), East African cassava mosaic Malawi virus (EACMMV), East African cassava mosaic Kenya virus (EACMKV), African cassava mosaic Burkina Faso virus (ACMBFV), Cassava mosaic Madagascar virus (CMMV) and Cassava brown streak virus (CBSV) (Bull *et al.*, 2006; Tiendrébéogo *et al.*, 2012).

Single and mixed infections of ACMV and EACMV occur in nature. For instance, while Eni and Fasasi (2013) reported sole infection of ACMV in Southern Nigeria, dual infections of ACMV and EACMV has been reported in Nigeria, Sierra Leone, Tanzania and Zambia (Harrison *et al.*, 1997; Chikoti *et al.*, 2013; Ogebe *et al.*, 2003; Samura *et al.*, 2014). *Begomoviruses* are transmitted by various species of whitefly (*Bemisia tabaci* Genn.). However, in addition to virus transmission, whiteflies cause injury to cassava through direct sucking of fluid from the cells of infested plants. Cassava mealybug (*Phenacoccus manihoti*) and cassava green mite (*Mononychellus tanajoa*) are also economic pests that cause severe damage to cassava (Évila *et al.*, 2012;



Yonow *et al.*, 2017). *African cassava mosaic virus* and *East African cassava mosaic virus* in singly infected plants can account for 100 % yield loss depending on virus strain and susceptibility of the cassava variety. Partial control of these viruses can be achieved through application of insecticides to suppress their insect vectors. However, adoption of resistant cultivars is the most sustainable strategy. The objective of this study was to determine the incidence and distribution of viruses infecting cassava in selected Local Government Areas of Oyo State, Nigeria.

## METHODOLOGY

### *Survey and Sample Collection*

Five Local Government Areas (Afijio, Akinyele, Atiba, Egbeda and Ikereku) of Oyo State were surveyed. Oyo State is located in the Southern part of Nigeria where a lot of cassava is cultivated. The survey was conducted in February, 2018 in popular cassava growing communities. In each Local Government Area (LGA), five cassava fields were visited. Leaf samples were collected from symptomatic cassava plants for ACMV and EACMV indexing. Three samples were collected from each field, making 15 samples in one LGA and a total of 75 samples from the five LGAs. The coordinates of each farm were recorded using Geographical Positioning System (GPS) device. Source of planting materials where available, size of the field, crops in adjacent fields and cropping history of each field were recorded. Symptomatic samples were detached from cassava stem and stored in the refrigerator at the temperature of 4 °C to avoid degradation pending the time of total nucleic acid extraction.

### *Total Nucleic Acid Extraction*

The leaf samples were analyzed at the Virology and Molecular Diagnostics Laboratory, International Institute of Tropical Agriculture (IITA), Ibadan, Oyo State. Samples were macerated at the rate of 0.50 mg mL<sup>-1</sup> of Cetyl Trimethyl Ammonium Bromide (CTAB) DNA extraction buffer containing monothioglycerol (1 µL/mL) in sterile mortars and pestles (Kumar, 2009). The extract was transferred into 1.5 mL eppendorf tubes and incubated in waterbath at 65 °C for 10 minutes. Tubes were brought to room temperature and 600 µL of phenol, chloroform and isoamyl in the ratio of 25:24:1 was added. The tubes were vortexed and centrifuged at 12000 g for 10 minutes. Thereafter, 450 µL of the supernatant was carefully transferred into new autoclaved 1.5 mL eppendorf tubes and 2/3 volumes of cold isopropanol/isopropyl alcohol was added to

the supernatant. The contents were mixed gently, incubated for one hour at -20 °C and then centrifuged at 12000 g for 10 minutes in order to sediment the nucleic acid. After this, the supernatant was carefully decanted. Then 500 µL of 70 % ethanol was added to the pellets and centrifuged at 12000 g for five minutes. The ethanol was carefully decanted and the DNA pellet was dried at 37 °C for 15 minutes. Thereafter, the DNA pellet was suspended in 50 µL of sterile distilled water and stored at -20 °C for further laboratory analysis.

### *Quantification of Extracted Samples and Integrity Testing by Agarose Electrophoresis*

Sample quantification was done using 1 µL of the suspended DNA stock with a NanoDrop spectrophotometer (Model 2000, ThermoScientific). DNA concentration was determined; protein purity was quantified at 260/280 and other impurities at 260/230. Integrity (quality) of the quantified samples was analysed using 5 µL of the DNA stock mixed with 3 µL of loading dye in a loading plate. Then, 7 µL of the mixed sample was run on ethidium bromide stained 1.5 % agarose gel in tris acetic ethylene diamine tetra acetic acid (EDTA) buffer (TAE buffer) at 120 V for 50 minutes. The result was obtained by exposing the gel to ultraviolet light (UV) using BIO RAD Gel Doc EZ imager.

## RESULTS AND DISCUSSION

Cassava was cultivated on 2 – 3 hectares in most of the fields visited. Symptoms such as leaf chlorosis, mosaic, curling and stunting were observed. The mosaic symptoms observed are in agreement with those reported by Samura *et al.* (2014) in some cassava producing zones of Sierra Leone. The diverse symptoms are in consonance with the observations of Patil and Fauquet (2009) who stated that different cassava viruses elicit different symptoms in susceptible cassava varieties. Whiteflies (*B. tabaci*) and cassava green mites were also rampant in most fields. The prevalence of whiteflies observed in this study agreed with the result obtained by Chikoti *et al.* (2015) in cassava mosaic disease (CMD) infected farms in Zambia. Whiteflies are important insects associated with numerous economic crops and are capable of transmitting several viruses including *Cassava mosaic virus*.

The incidence of CMD was generally low in all the surveyed locations. Of the 75 samples collected, five (6.7 %) from Akinyele LGA tested positive for ACMV (Fig. 1 and Table1). These samples were collected from Forobi, Ehin Oke and Otun Agbaakin. Within Akinyele LGA, three (4 %) samples collected from Ehin Oke were found positive for ACMV; one

(1.3 %) sample each was positive for ACMV at Forobi and Otun Agbaakin. Additionally, two (2.7 %) samples collected from Akinyele LGA were positive for EACMV and both were collected from Ehin Oke community (Fig. 1 and Table 1). The location (Ehin Oke) where both ACMV and EACMV were found is one of the major cassava-producing areas in Akinyele LGA. The incidence of the viruses could partly be attributable to the sources of planting materials. Based on the interview conducted during the survey, some of the farmers did not cultivate improved cassava varieties. Occurrence of ACMV and EACMV in the same location, as observed in the present study is consistent with the findings of Ogbé *et al.* (2006) during an extensive survey of some cassava growing States in Nigeria.

None of the samples from Afijio LGA tested positive for ACMV and EACMV (Table 1). This could be attributable to the level of adoption of improved cassava varieties. Thus, all the farmers interviewed confirmed that they normally obtained planting materials from the International Institute of Tropical Agriculture (IITA), Ibadan, Oyo State. In Atiba LGA, two (2.7 %) samples tested positive for ACMV only and both samples were collected from Soro Osunyin (Fig. 1 and Table 1). In Egbeda LGA, five (6.7 %) samples tested positive for ACMV and all of them were collected from Egbeda community. Similarly, in Ikereku LGA, five (6.7 %) samples tested positive for ACMV. In this LGA, the highest incidence of ACMV was found at Odebode which had three (4 %) ACMV positive samples while two (2.7 %) samples were positive at Aba Oluode (Table 1). Some of the cassava plants that elicited reduced leaf size, mosaic and “candle stick” tested negative to ACMV and EACMV, suggesting that the symptoms were possibly induced by insect vectors or other pathogens (Chikoti *et al.*, 2015).

#### **CONCLUSION AND RECOMMENDATIONS**

This study revealed low incidence and distribution of ACMV and EACMV in Akinyele LGA, ACMV alone in three LGAs (Atiba, Egbeda and Ikereku) and none in Afijio LGA. In spite of the low occurrence of these viruses, adoption of resistant cultivars should be intensified by cassava farmers as a precautionary measure against the diseases.

#### **ACKNOWLEDGEMENTS**

Authors are grateful to the Virology and Molecular Diagnostics Unit, International Institute of Tropical Agriculture (IITA), Ibadan for the technical support.

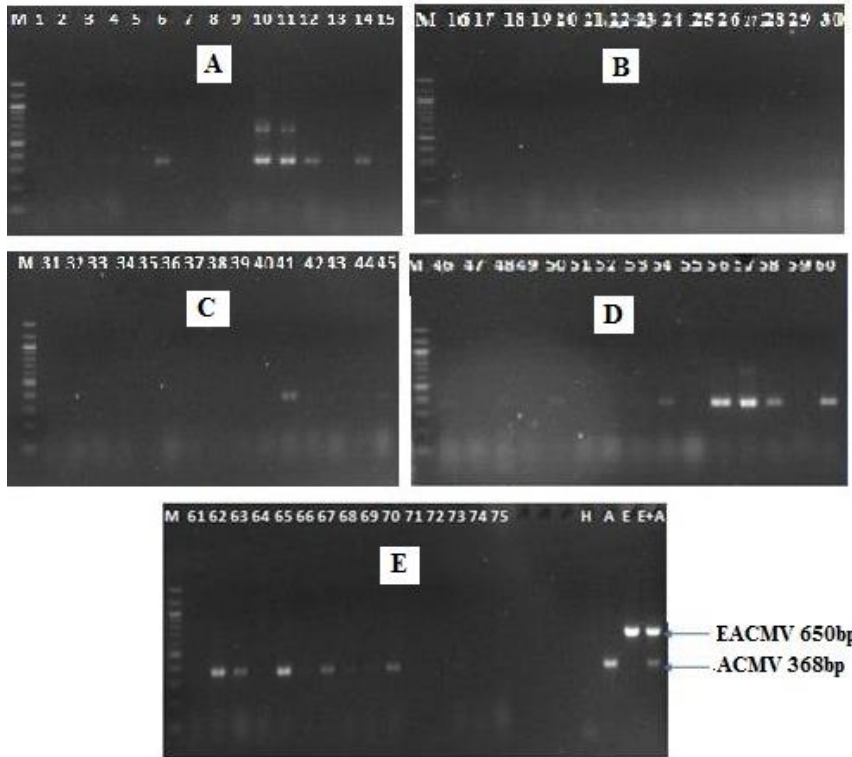


Fig. 1: Gel picture of the *African cassava mosaic virus* (ACMV) and *East African cassava mosaic virus* (EACMV) bands from cassava leaves sampled from (A) Akinyele, (B) Afijio, (C) Atiba, (D) Egbeda and (E) Ikereku Local Government Areas of Oyo State

1 -75 = Leaf samples ID from the various locations



**Table 1:** Incidence of *African cassava mosaic virus* and *East African cassava mosaic virus* in selected Local Government Areas (LGAs) of Oyo State, Nigeria in 2018

LGA	Location	Longitude (°E)	Latitude (°N)	Altitude (masL)	Virus Primer	
					ACMV	EACMV
Akinyele	Aba odo	3.91747	7.56951	267	-	-
	Aba odo	3.91747	7.56951	267	-	-
	Aba odo	3.91747	7.56951	267	-	-
	Forobi	3.92600	7.57077	268	-	-
	Forobi	3.92600	7.57077	268	-	-
	Forobi	3.92600	7.57077	268	+	-
	Ehin Oke	3.92567	7.50066	289	-	-
	Ehin Oke	3.92567	7.50066	289	-	-
	Ehin Oke	3.92567	7.50066	289	-	-
	Ehin Oke	3.92543	7.50045	213	+	+
	Ehin Oke	3.92543	7.50045	213	+	+
	Ehin Oke	3.92543	7.50045	213	+	-
	Otun Agbaakin	3.92442	7.50144	225	-	-
	Otun Agbaakin	3.92442	7.50144	225	+	-
	Otun Agbaakin	3.92442	7.50144	225	-	-
Afijio	Alaaka	3.91528	7.79877	305	-	-
	Alaaka	3.91528	7.79877	305	-	-
	Alaaka	3.91528	7.79877	305	-	-
	Jobele	3.91719	7.76487	272	-	-
	Jobele	3.91719	7.76487	272	-	-
	Jobele	3.91719	7.76487	272	-	-
	Jobele	3.91587	7.76104	284	-	-
	Jobele	3.91587	7.76104	284	-	-
Healthy control					-	-
ACMV Disease control					+	-
EACMV Disease control					-	+++
ACMV+ EACMV Diseased control					+	++

masl=metres above sea level

**Table 1 Continued:** Incidence of *African cassava mosaic virus* and *East African cassava mosaic virus* in selected Local Government Areas (LGAs) of Oyo State, Nigeria in 2018

LGA	Location	Longitude ( <sup>0</sup> E)	Latitude ( <sup>0</sup> N)	Altitude (masL)	Virus Primer	
					ACMV	EACMV
Afijio	Jobele	3.91587	7.76104	284	-	-
	Jobele	3.91171	7.74915	291	-	-
	Jobele	3.91171	7.74915	291	-	-
	Jobele	3.91171	7.74915	291	-	-
	Alaaka	3.91189	7.92740	284	-	-
	Alaaka	3.91189	7.92740	284	-	-
Atiba	Alaaka	3.91189	7.92740	284	-	-
	Obakayeja	3.91130	7.92740	281	-	-
	Obakayeja	3.91130	7.92740	281	-	-
	Obakayeja	3.91130	7.92740	281	-	-
	Obakayeja	3.91189	7.92740	284	-	-
	Obakayeja	3.91189	7.92740	284	-	-
	Obakayeja	3.91189	7.92740	284	-	-
	Obakayeja	3.91189	7.92740	284	-	-
	Obakayeja	3.91116	7.92664	276	-	-
	Obakayeja	3.91116	7.92664	277	-	-
	Obakayeja	3.91116	7.92664	278	-	-
	Soro Osunyin	3.92292	7.92123	262	-	-
	Soro Osunyin	3.92292	7.92123	262	+	-
	Soro Osunyin	3.92292	7.92123	262	-	-
	Soro Osunyin	3.93550	7.87220	289	-	-
Soro Osunyin	3.93550	7.87220	289	-	-	
Soro Osunyin	3.93550	7.87220	289	+	-	
Egbeda	Iyana Ajia	3.92000	7.55608	254	-	-
	Iyana Ajia	3.92000	7.55608	254	-	-
	Iyana Ajia	3.92000	7.55608	254	-	-
	Iyana Ajia	3.92033	7.55662	258	-	-
	Iyana Ajia	3.92033	7.55662	258	-	-
	Iyana Ajia	3.92033	7.55662	258	-	-
	Egbeda	3.92043	7.55669	256	-	-
	Egbeda	3.92043	7.55669	256	-	-
Healthy control					-	-
ACMV Disease control					+	-
EACMV Disease control					-	+++
ACMV+ EACMV Disease control					+	++

masl=metres above sea level

**Table 1 Continued:** Incidence of *African cassava mosaic virus* and *East African cassava mosaic virus* in selected Local Government Areas (LGAs) of Oyo State, Nigeria in 2018

LGA	Location	Longitude (°E)	Latitude (°N)	Altitude (masL)	Virus Primer	
					ACMV	EACMV
Egbeda	Egbeda	3.92043	7.55669	256	+	-
	Egbeda	3.92102	7.55624	252	-	-
	Egbeda	3.92102	7.55624	252	+	-
	Egbeda	3.92102	7.55624	252	++	-
	Egbeda	3.92013	7.55639	259	+	-
	Egbeda	3.92013	7.55639	259	-	-
	Egbeda	3.92013	7.55639	259	+	-
Ikereku	Odebode	3.92798	7.57683	291	-	-
	Odebode	3.92798	7.57683	291	++	-
	Odebode	3.92798	7.57683	291	+	-
	Odebode	3.92756	7.57612	288	-	-
	Odebode	3.92756	7.57612	288	++	-
	Odebode	3.92756	7.57612	288	-	-
	Aba Oluode	3.92553	7.57551	300	+	-
	Aba Oluode	3.92553	7.57551	300	-	-
	Aba Oluode	3.92553	7.57551	300	-	-
	Aba Oluode	3.92782	7.57674	292	+	-
	Aba Oluode	3.92782	7.57674	292	-	-
	Aba Oluode	3.92782	7.57674	292	-	-
	Olukitibi	3.92727	7.57214	272	-	-
	Olukitibi	3.92727	7.57214	272	-	-
Olukitibi	3.92727	7.57214	272	-	-	
Healthy control					-	-
ACMV Disease control					+	-
EACMV Disease control					-	+++
ACMV+ EACMV Disease control					+	++

masl=metres above sea level



## REFERENCES

- Bull, S. E., Briddon, R. W., Sserubombwe, W. S., Ngugi, K., Markham, P. G. and Stanley, J. (2006). Genetic diversity and phylogeography of cassava mosaic viruses in Kenya. *J Gen. Virol.*, 87:3053-3065.
- Chikoti, P. C., Tembo, M., Chisola, M., Ntawuruhunga, P. and Ndunguru, J. (2015). Status of cassava mosaic disease and whitefly population in Zambia. *Afr. J. Biotech.*, 14: 2539 – 2546.
- Chikoti, P. C., Ndunguru, J., Melis, R., Tairo, F., Shanahan, P. and Sseruwagi, P. (2013). Cassava mosaic disease and associated viruses in Zambia: occurrence and distribution. *Int. J. Pest Manag.*, 59: 63-72
- Eni, A. O. and Fasasi, D. K. (2013). Molecular detection of two cassava *Begomoviruses* in some parts of Southern Nigeria. *Afr. J. Agric. Res.*, 8:1350 – 1353.
- Évila, C. C., Adenir, V. T. O., Rêgo, A. S., Anilde, G. S. M. and Renato, A. S. (2012). Population structure and dynamics of the cassava green mite *Mononychellus tanajoa* (Bondar) and the predator *Euseius ho*(DeLeon) (Acari: Tetranychidae, Phytoseiidae). *Arthropods* 1:55-62.
- FAO (Food and Agriculture Organization). (2016). Cassava production. Available at <http://www.fao.org/faostat/en/#data/QC/visualize>
- Harrison, B. D., Zhou, X., Otim-Nape, G. W., Liu, Y. and Robinson, D. J. (1997). Role of a novel type of double infection in the geminivirus-induced epidemic of severe cassava mosaic in Uganda. *Ann. Appl. Biol.*, 131:437-448.
- Kumar, P. L. (2009). Methods for the Diagnosis of plant virus diseases: Laboratory manual. International Institute of Tropical Agriculture (IITA), Ibadan, Nigeria. Pp. 90.
- Ogbe, F. O., Thottappilly, G., Dixon, A. G. O., Atiri, G. I. and Mignouna, H. D. (2003). Variants of East African cassava mosaic virus and its distribution in double infections with African cassava mosaic virus in Nigeria. *Plant Dis.*, 87:229-232.
- Ogbe, F. O., Dixon, A. G. O., Hughes, J. d'A., Alabi, O. J., and Okechukwu, R. (2006). Status of cassava begomoviruses and their new natural hosts in Nigeria. *Plant Dis.*, 90:548-553.
- Patil, B. L. and Fauquet, C. M. (2009). Cassava mosaic geminiviruses: actual knowledge and perspectives. *Mol. Plant Pathol.*, 10:685-701.
- Tiendrébéogo, F., Lefeuvre, P., Hoareau, M., Harimalala, M. A., De Bruyn, A., Villemot, J., Traoré, V. S. E., Konaté, G., Traoré, A. S., Barro, N., Reynaud, B., Traoré, O. and Lett, J. M. (2012). Evolution of *African cassava mosaic virus* by recombination between bipartite and monopartite begomoviruses. *Virol. J.*, 9:67.
- Samura, A. E., Massaquoi, F. B., Mansaray, A., Kumar, P. L., Koroma, J. P. C., Fomba, S. N. and Dixon, A. G. O. (2014). Status and diversity of the cassava mosaic disease causal agents in Sierra Leone. *Int. J. Agric. Forestry*, 4(3): 246 – 25.
- Yonow, T., Kriticos, D. J. and Ota, N. (2017). The potential distribution of cassava mealybug (*Phenacoccus manihoti*), a threat to food security for the poor. *PLoS One*, 12(3): e0173265. doi:10.1371/journal.pone.0173265.

## OCCURRENCE AND DISTRIBUTION OF PEPPER (*Capsicum* spp.) VIRUSES IN NIGER STATE, NIGERIA

Adama\*, C. J., Salaudeen, M. T. and Bello, L. Y.

Department of Crop Production, School of Agriculture and Agricultural Technology,  
Federal University of Technology, P.M.B. 65, Minna, Niger State, Nigeria

\*Corresponding Author's E-mail: [cinwonj@gmail.com](mailto:cinwonj@gmail.com) GSM: 07065598936

### ABSTRACT

Pepper is an important global food crop for the supply of vitamins and minerals for proper human growth. Virus diseases are responsible for huge losses in crop production and quality all over the world. Therefore, there is need for continuous survey in order to identify the virus types within a particular area which can be used by plant breeders to develop resistant cultivars. The objective of the study was to determine the incidence and distribution of pepper viruses in some Local Government Areas of Niger State. Surveys were carried out during the 2018 dry and wet seasons in selected Local Government Areas (Bida, Bosso, Mashegu, Mokwa and Wushishi) of Niger State, Nigeria. One hundred symptomatic leaf samples of pepper plants were collected randomly from 20 fields and were analyzed for viruses using Double Antibody Sandwich Enzyme-Linked Immunosorbent Assay (DAS-ELISA) with three polyclonal antibodies (PABs) for Cucumber mosaic virus (CMV), Pepper vein mottle virus (PVMV) and Potato virus Y (PVY). Symptoms observed on fields included leaf chlorosis, mosaic, mottling, leaf and fruit deformation and stunting. All the tested samples reacted negatively to Potato virus Y (PVY) PAB. In all, 5 % of the samples collected from Bosso Local Government Area (LGA) reacted positively to CMV PAB. However, 65 % of the samples collected from Bida LGA tested positive for PVMV. This was closely followed by 25 % positive reaction to PVMV in Mashegu LGA. Moreover, 10 % positive reaction to PVMV was found in the samples collected at Bosso LGA. The study revealed the prevalence of PVMV and the presence of CMV in the study area. In order to prevent severe yield losses, pepper farmers should adhere to proper sanitation, use of clean seeds and rouging of infected plant stands. The inocula of these viruses can be used for breeding available CMV and PVMV resistant pepper cultivars.

**KEYWORDS:** Pepper viruses, DAS-ELISA, Niger State, CMV, PVMV

### INTRODUCTION

Pepper (*Capsicum* spp.) originated from South and Central America and is a member of the Solanaceae family. It is one of the world's most popular vegetables which can be consumed fresh or processed and used mainly as a spice and condiment. In 2016, the world production of peppers was estimated at 546.3 million tonnes. Nigeria was the largest producer in Africa with about 67, 000 tonnes (FAO, 2016). Virus diseases annually reduce yield and quality of pepper. Symptoms of virus infection vary widely in expression and severity including mild mottle, mosaic, vein banding, ring spots, necrosis, leaf discoloration, deformation and blistering and severe stunting of the whole plant.

Studies have shown that about 40 viruses infect peppers (Kim *et al.*, 2009). The genus *Potyvirus* (family *Potyviridae*) containing about 200 species accounts for almost 25 % of known plant viruses. Species belonging to this genus can share many common properties. Arogundadeet *al.* (2012) has reported high incidence of *Pepper vein mottle*

*virus* (PVMV) and *Cucumber mosaic virus* (CMV) in Nigeria. Other studies have also revealed the occurrence of *Potato virus Y* (PVY), *PotatovirusX* (PVX), *Pepper mild mottle virus* (PMMV), *Tobacco mosaic virus* (TMV), *Tobacco etch virus* (TEV) and *Tomato mosaic virus* (ToMV) (Arogundadeet *al.*, 2015). *Cucumber mosaic virus* is a single-stranded RNA virus, tripartite and 29 nm in diameter. Virions contain 18 and 82 % nucleic acid and protein, respectively. Particles are found in all parts of the host specifically in the cytoplasm and inclusion bodies are present in infected cells (Roossinck, 2013). *Cucumber mosaic virus* has a wide host range and can cause complete crop loss. *Pepper vein mottle virus* is transmitted by several species of aphids. It can also be transmitted mechanically. Leaves of infected plants show chlorotic vein banding, mottling mosaic and distortion with puckering. Losses could be as high as 90 %. Similarly, *Potato virus Y* (PVY) also induces severe crop losses in pepper production. Symptoms of PVY disease include plant stunting, systemic vein-clearing, leaf mosaic or mottling, and dark green vein-banding



of the leaves. Necrosis in the veins and petioles often develop. This may be followed by stem necrosis and defoliation, death of the top bud and plant death. Affected fruit may be smaller, deformed, and with a mosaic pattern. *Potato virus Y* symptoms may be masked by symptoms of other viruses (AVRDC, 2004).

Identification of the viruses infecting pepper in Niger State would be useful for designing control measures. This can be achieved by using identified viruses infecting pepper for screening against the available locally adapted pepper accessions. Identification of high virus resistant and high yielding accessions would in turn lead to increased production and food security (Elvis *et al.*, 2014). Therefore, the objective of the study was to determine the incidence and distribution of pepper viruses in some Local Government Areas of Niger State.

## METHODOLOGY

### Survey

Surveys were carried out to determine the occurrence and distribution of pepper viruses during the 2018 dry and wet season in selected Local Government Areas of Niger State (Bida, Bosso, Mashegu, Mokwa and Wushishi). A total of 100 leaf samples were collected from 20 pepper fields from infected plants showing symptoms such as chlorosis, mosaic, mottling, leaf and fruit deformation and stunting. Young leaf samples of infected plants were collected and stored in vial bottles containing self-indicating silica gels and non-absorbent cotton wool until analyzed. The coordinates of each farm were captured using the Geographical Positioning System (GPS) equipment (GPS- 4300; Ethrex Garmin GPS, Taiwan). Concise information including date and time of visit, farm size, cropping system, crops in neighbouring fields, fertilizer applications, insect pest and disease management strategies was recorded.

### Virus Identification and Data Analysis

Leaf samples were tested for the presence of CMV, PVMV and PVY using Double Antibody Sandwich Enzyme-Linked Immunosorbent Assay (DAS-ELISA). DAS-ELISA was performed in accordance with the manufacturer's instructions using CMV, PVMV and PVY specific polyclonal antisera purchased from Leibniz-institut, Deutsche Sammlung von Mikroorganismen und Zellkulturen Braunschweig, Germany.

For DAS-ELISA, the wells of polystyrene microplates (Corning, NY 14831, USA) were coated with 200  $\mu$ L of the corresponding antiserum diluted to 1000-fold (1:1000) in coating buffer (0.05 M

sodium carbonate, pH 9.6) and incubated at 37 °C for 2 hours. Incubated plates were washed three times with PBS-Tween (phosphate-buffered saline-Tween containing PBS and 0.5 ml Tween 20 per litre). Plates were blotted by tapping upside down on tissue paper. Samples were extracted (1:20 w/v) in extraction buffer [containing PBST and 2 % PVP (e.g. Serva PVP – 15 polyvinyl pyrrolidone)]. Two hundred  $\mu$ L aliquots of each sample were added to duplicate wells, covered and incubated overnight at 4 °C. Extraction buffers were used as negative controls. The incubated plates were washed three times, followed by addition of 200  $\mu$ L alkaline phosphatase (AP) conjugated IgG at 1:1,000 dilution in conjugate buffer (phosphate-buffered saline, pH 7.4, containing 0.05 % Tween 20 and 0.2 % egg albumin). The plates were covered and again incubated at 37 °C for 2 hours. Thereafter, the plates were washed three times as described above and blotted on tissue paper. The alkaline phosphatase substrate tablets (Sigma-Aldrich, St. Louis, MO, USA) were prepared in the substrate buffer (9.7 % di-ethanolamine, pH 9.8) to a final concentration of 1 mg mL<sup>-1</sup>. One hundred microliters of *p*-nitrophenyl phosphate substrate was added to each well and the plates were incubated for 60 minutes at 37 °C. Absorbance values were read at 405 nm using a microplate reader (iMark Microplate Absorbance Reader (Bio-Rad), Germany). Samples were considered to be positive when the mean of the absorbance values at 405 nm ( $A_{405}$ ) was twice the negative controls. Disease incidences were calculated as percentage of total number of infected samples that tested positive for the viruses.

## RESULTS AND DISCUSSION

Pepper in the surveyed areas was grown on not less than one hectare of land for sale and also for family consumption. Farmers cultivated pepper twice a year both during the dry and wet seasons. Pepper cultivation during the dry season is made possible with irrigation and proximity to source of water usually rivers. Pepper was grown in mixtures with other principal food crops such as maize, cassava, cowpea, millet, rice, okra and groundnut. The farmers interviewed stated that they usually buy seeds from the market or from previous harvest. Similarly, weeds were controlled manually and pesticides were used to control insect pests and diseases. Inorganic fertilizers such as NPK and urea were the main source for soil improvement. The presence of some diseased conditions was attributed to the late arrival of rain. The farmers were willing to source seeds and other agricultural inputs from reliable sources like the Research institutes, Ministries of Agriculture and Agricultural Development Projects (ADPs).



The symptoms observed on the pepper fields were mosaic, yellowing and leaf mottling. About 5 % of the samples exhibited strong positive reaction to CMV antibody (Fig. 1 and Table 1). The incidence of CMV was observed at Dokumgba in Bida LGA. *Cucumber mosaic virus* was not detected in Bosso, Wushishi, Mokwa and Mashegu LGA. Ten percent of the indexed samples collected in Bosso LGA showed strong positive reaction to PVMV antibody (Fig. 1 and Table 2). The samples that tested positive for PVMV were collected at Angwan-Gwari and Chanchaga. Furthermore, 20 % of the samples collected from Wushishi LGA exhibited strong positive reaction to PVMV antibody. The PVMV incidence in Wushishi was observed at Bogi and Mailema with higher incidence at Mailema. In Mokwa LGA, 15 % PVMV disease incidence was observed. Incidence of PVMV was highest at Muwo (5 %); this was closely followed by Mokwa township (5 %) and Bokani (5 %). Additionally, 25 % of the samples were positive for PVMV antibody (Table 2) in Mashegu LGA. The positive samples were collected from Makera (5 %) and Manigi (20 %). In Bida LGA, 65 % of the samples tested positive for PVMV PABs. The incidence of PVMV was wide spread across all the farms visited in Bida LGA at Dokumgba (60 %), and Kuchi (5 %). All the samples reacted negatively to PVY antibody (Table 3).

The serological method used revealed the occurrence of two viruses in pepper farms across the surveyed areas as single infections. *Pepper veinal mottle virus* was the most occurring virus followed by CMV. The higher incidence of PVMV observed in Bida LGA implied that it was a hotspot of the virus. *Pepper veinal mottle virus* (PVMV) has been previously reported as one of the most prevalent viruses infecting pepper in south west Nigeria (Fajinmi, 2010). The high occurrence of PVMV could be attributed to its ability to survive in weed hosts for relatively long period of time (Agrios, 2005) and other vegetables. This confirms the findings of Alegbejo (2015) who reported that the nearness of pepper plants to certain important weed hosts also has contributed greatly to the spread of virus diseases of pepper. The wide spread of PVMV within crops could occur due to mechanical transmission by farmers ranging from contaminated hands, clothing, and tools during routine farm operations such as transplanting, pruning, grafting, and other farm activities. Fajinmi *et al.* (2011) suggested that the incidence and severity on susceptible cultivars can be reduced or eliminated with the knowledge of the ecology and distribution of aphid vectors within a particular area.

## CONCLUSION AND RECOMMENDATIONS

Adoption of early planting, integrated pest management, good field sanitation, weeding, and rouging of infected pepper stands will serve as other management techniques (Fajinmi *et al.*, 2012). The inocula of the identified CMV and PVMV could be used for screening some available pepper cultivars for resistance and breeding purposes.

**Table 1: Serological reactions of pepper leaves to *Cucumber mosaic virus* (CMV) antibody**

Sample ID	CMV Antibody	Sample ID	CMV Antibody	Sample ID	CMV Antibody
BO 1.1	0.154	WU 7.5	0.161	MS 14.3	0.163
BO 1.2	0.135	WU 8.1	0.145	MS 14.4	0.155
BO 1.3	0.106	WU 8.2	0.146	MS 14.5	0.153
BO 1.4	0.157	WU 8.3	0.143	MS 15.1	0.142
BO 1.5	0.115	WU 8.4	0.156	MS 15.2	0.143
BO 2.1	0.157	WU 8.5	0.131	MS 15.3	0.141
BO 2.2	0.149	MO 9.1	0.129	MS 15.4	0.149
BO 2.3	0.114	MO 9.2	0.143	MS 15.5	0.181
BO 2.4	0.176	MO 9.3	0.142	MS 16.1	0.157
BO 2.5	0.148	MO 9.4	0.115	MS 16.2	0.171
BO 3.1	0.096	MO 9.5	0.097	MS 16.3	0.192
BO 3.2	0.124	MO 10.1	0.144	MS 16.4	0.166
BO 3.3	0.125	MO 10.2	0.111	MS 16.5	0.158
BO 3.4	0.147	MO 10.3	0.217	BD 17.1	0.155
BO 3.5	0.138	MO 10.4	0.176	BD 17.2	0.170
BO 4.1	0.157	MO 10.5	0.138	BD 17.3	0.172
BO 4.2	0.132	MO 11.1	0.185	BD 17.4	0.347*
BO 4.3	0.153	MO 11.2	0.155	BD 17.5	0.171
BO 4.4	0.168	MO 11.3	0.157	BD 18.1	0.161
BO 4.5	0.149	MO 11.4	0.148	BD 18.2	0.150
WU 5.1	0.115	MO 11.5	0.152	BD 18.3	0.192
WU 5.2	0.132	MO 12.1	0.175	BD 18.4	0.168
WU 5.3	0.132	MO 12.2	0.17	BD 18.5	0.170
WU 5.4	0.134	MO 12.3	0.191	BD 19.1	0.172
WU 5.5	0.154	MO 12.4	0.170	BD 19.2	0.174
WU 6.1	0.154	MO 12.5	0.215	BD 19.3	0.146
WU 6.2	0.161	MS 13.1	0.168	BD 19.4	0.153
WU 6.3	0.151	MS 13.2	0.132	BD 19.5	0.163
WU 6.4	0.128	MS 13.3	0.148	BD 20.1	0.170
WU 6.5	0.140	MS 13.4	0.152	BD 20.2	0.143
WU 7.1	0.151	MS 13.5	0.181	BD 20.3	0.150
WU 7.2	0.156	MS 14.1	0.157	BD 20.4	0.184
WU 7.3	0.158	MS 14.2	0.157	BD 20.5	0.137
WU 7.4	0.148				

Positive control = 0.272; Buffer control = 0.136; \*Positive reaction;  
 BO = Bosso; WU = Wushishi; MO = Mokwa; MS = Mashegu; BD = Bida

**Table 2: Serological reactions of pepper leaves to *Pepper veinal mottle virus (PVMV)* antibody**

Sample ID	PVMV Antibody	Sample ID	PVMV Antibody	Sample ID	PVMV Antibody
BO 1.1	0.250	WU 7.5	0.192	MS 14.4	0.128
BO 1.2	0.164	WU 8.1	0.184	MS 14.5	0.118
BO 1.3	0.202	WU 8.2	0.143	MS 15.1	0.093
BO 1.4	0.246	WU 8.3	0.155	MS 15.2	0.163
BO 1.5	0.168	WU 8.4	0.114	MS 15.3	0.120
BO 2.1	0.216	WU 8.5	0.104	MS 15.4	0.125
BO 2.2	0.187	MO 9.1	0.076	MS 15.5	0.137
BO 2.3	0.229	MO 9.2	0.081	MS 16.1	0.155
BO 2.4	0.297*	MO 9.3	0.086	MS 16.2	0.706*
BO 2.5	0.173	MO 9.4	0.117	MS 16.3	0.813*
BO 3.1	0.208	MO 9.5	0.144	MS 16.4	0.300*
BO 3.2	0.152	MO 10.1	0.130	MS 16.5	0.576*
BO 3.3	0.107	MO 10.2	0.124	BD 17.1	0.467*
BO 3.4	0.100	MO 10.3	0.353*	BD 17.2	0.633*
BO 3.5	0.143	MO 10.4	0.089	BD 17.3	0.782*
BO 4.1	0.196	MO 10.5	0.124	BD 17.4	0.185
BO 4.2	0.226	MO 11.1	0.140	BD 17.5	0.785*
BO 4.3	0.162	MO 11.2	0.042	BD 18.1	0.504*
BO 4.4	0.305*	MO 11.3	0.086	BD 18.2	0.156
BO 4.5	0.243	MO 11.4	1.086**	BD 18.3	0.322*
WU 5.1	0.345*	MO 11.5	0.135	BD 18.4	0.211*
WU 5.2	0.201	MO 12.1	0.107	BD 18.5	0.471*
WU 5.3	0.102	MO 12.2	0.117	BD 19.1	0.446*
WU 5.4	0.317*	MO 12.3	0.096	BD 19.2	0.731*
WU 5.5	0.160	MO 12.4	0.441*	BD 19.3	0.359*
WU 6.1	0.171	MO 12.5	0.133	BD 19.4	0.440*
WU 6.2	1.053**	MS 13.1	0.453*	BD 19.5	0.151
WU 6.3	0.210	MS 13.2	0.111	BD 20.1	0.157
WU 6.4	0.085	MS 13.3	0.148	BD 20.2	0.177
WU 6.5	0.169	MS 13.4	0.128	BD 20.3	0.142
WU 7.1	0.538*	MS 13.5	0.160	BD 20.4	0.445*
WU 7.2	0.213	MS 14.1	0.130	BD 20.5	0.110
WU 7.3	0.222	MS 14.2	0.140		
WU 7.4	0.134	MS 14.3	0.119		

Positive control = 0.270; Buffer control = 0.135; \*Positive reaction;  
 BO = Bosso; WU = Wushishi; MO = Mokwa; MS = Mashegu; BD = Bida



**Table 3: Serological reactions of pepper leaves to *Potato virus Y* (PVY) antibody**

Sample ID	PVY Antibody	Sample ID	PVY Antibody	Sample ID	PVY Antibody
BO 1.1	0.141	WU 7.5	0.140	MS 14.4	0.144
BO 1.2	0.126	WU 8.1	0.133	MS 14.5	0.145
BO 1.3	0.139	WU 8.2	0.128	MS 15.1	0.139
BO 1.4	0.134	WU 8.3	0.112	MS 15.2	0.126
BO 1.5	0.107	WU 8.4	0.101	MS 15.3	0.130
BO 2.1	0.130	WU 8.5	0.085	MS 15.4	0.145
BO 2.2	0.111	MO 9.1	0.111	MS 15.5	0.166
BO 2.3	0.150	MO 9.2	0.102	MS 16.1	0.166
BO 2.4	0.166	MO 9.3	0.101	MS 16.2	0.158
BO 2.5	0.167	MO 9.4	0.121	MS 16.3	0.153
BO 3.1	0.101	MO 9.5	0.117	MS 16.4	0.139
BO 3.2	0.107	MO 10.1	0.139	MS 16.5	0.142
BO 3.3	0.091	MO 10.2	0.116	BD 17.1	0.150
BO 3.4	0.112	MO 10.3	0.122	BD 17.2	0.137
BO 3.5	0.121	MO 10.4	0.113	BD 17.3	0.144
BO 4.1	0.105	MO 10.5	0.124	BD 17.4	0.153
BO 4.2	0.116	MO 11.1	0.144	BD 17.5	0.160
BO 4.3	0.105	MO 11.2	0.153	BD 18.1	0.149
BO 4.4	0.134	MO 11.3	0.143	BD 18.2	0.174
BO 4.5	0.131	MO 11.4	0.157	BD 18.3	0.180
WU 5.1	0.116	MO 11.5	0.171	BD 18.4	0.142
WU 5.2	0.131	MO 12.1	0.156	BD 18.5	0.160
WU 5.3	0.124	MO 12.2	0.174	BD 19.1	0.141
WU 5.4	0.126	MO 12.3	0.207	BD 19.2	0.150
WU 5.5	0.156	MO 12.4	0.205	BD 19.3	0.142
WU 6.1	0.147	MO 12.5	0.187	BD 19.4	0.152
WU 6.2	0.145	MS 13.1	0.163	BD 19.5	0.152
WU 6.3	0.135	MS 13.2	0.130	BD 20.1	0.214
WU 6.4	0.104	MS 13.3	0.149	BD 20.2	0.200
WU 6.5	0.135	MS 13.4	0.140	BD 20.3	0.151
WU 7.1	0.122	MS 13.5	0.147	BD 20.4	0.223
WU 7.2	0.122	MS 14.1	0.153	BD 20.5	0.139
WU 7.3	0.131	MS 14.2	0.148		
WU 7.4	0.124	MS 14.3	0.144		

Positive control =0.266; Buffer control = 0.133; \*Positive reaction;  
 BO = Bosso; WU = Wushishi; MO = Mokwa; MS = Mashegu; BD = Bida

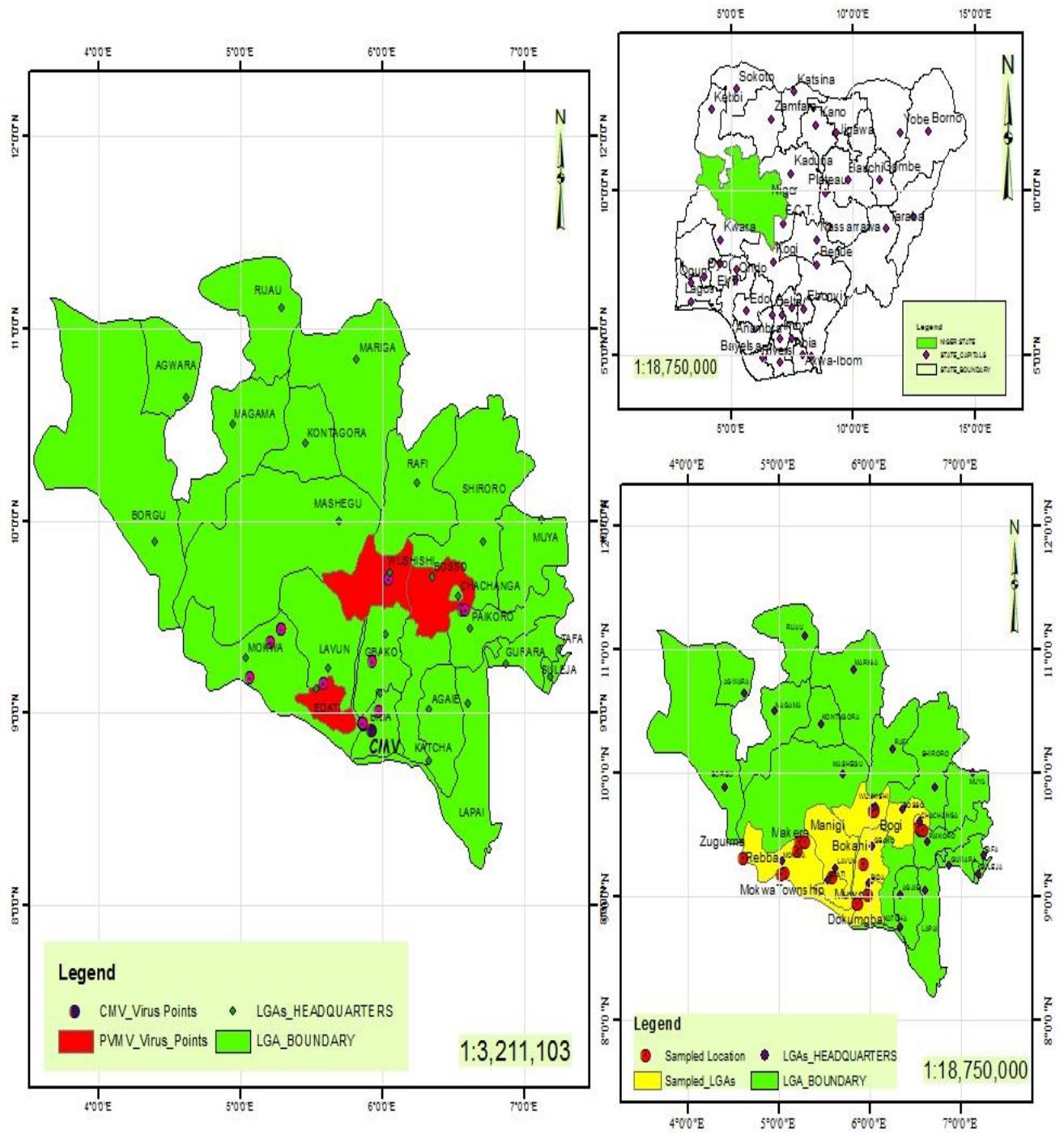


Fig. 1: Maps showing sampling points and distribution of *Cucumber mosaic virus* (CMV), *Pepper vein mottle virus* (PVMV) and *Potato virus Y* (PVY) in Niger State, Nigeria

## REFERENCES

- Agrios G. N. (2005). *Plant Pathology*. Fifth Edition. Elsevier Academic Press. 30 Corporate Drive, Suite 400, Burlington, MA 01803, USA 525 B Street, Suite 1900, San Diego, California 92101-4495, USA 84 Theobald's Road, London WC1X 8RR, UK.
- Alegbejo, M. D. (2015). Virus and virus-like diseases of crops in Nigeria. *Zaria, Nigeria, Ahmadu Bello University Press*, 12, 89-91.
- Arogundade, O., Balogun, O. S. and Kareem, K. T. (2012). Occurrence and distribution of *Pepper veinal mottle virus* and *Cucumber mosaic virus* in pepper in Ibadan, Nigeria. *Virology Journal*, 9:79.
- Arogundade, O., Balogun, O. S., Akinyemi, S. O. S. and Kumar, P. L. (2015). Surveys of virus diseases on pepper (*Capsicum* spp.) in South-west Nigeria. *African Journal of Biotechnology*, 14(48): 3198-3205.
- Asian Vegetable Research and Development Center (AVRDC). (2004). Fact Sheet; *Peppermottlevirus*. Asian Vegetable Research and Development Center (AVRDC) Publication.
- Elvis, A., Albert, A. and Appiah, B. (2014). Comparative Efficacy of Phytopesticides in the management of *Podagrica SPP*. And Mosaic Disease on Okra (*Abelmoschus esculentus* L.). *American Journal of Experimental Agriculture*, 4(8): 879-889.
- Food and Agriculture Organization (FAO). (2016). Tomato production statistics. Available at <http://faostat.fao.org/site/567/DesktopDefault.aspx?PageID=567#anchor> Accessed on May 1, 2017.
- Fajinmi, A. A. (2010). Agro-ecological incidence and severity of *Pepper veinal mottle virus*, genus *Potyvirus*, Family Potyviridae, on cultivated pepper (*Capsicum annuum* L.) in Nigeria. 21st International Conference on Virus and other Graft Transmissible Diseases of Fruit Crops. Julius-Kühn-Archiv, 427. pp. 314-322.
- Fajinmi, A. A., Odebode, C. A. and Fajinmi, O. B. (2011). Incidence and distribution of aphid vectors of *Pepper veinal mottle virus* on bell pepper. *International Journal of Entomology*, 1(1): 1-12.
- Fajinmi, A. A., Popoola, A. R. and Fajinmi, O. B. (2012). Incidence and epidemiology of *Pepper veinal mottle virus* (PVMV), a Potyvirus disease of pepper. *Archives of Phytopathology and Plant Protection*. DOI:10.1080/03235408.2012.694250.
- Kim M., Suh, H., Cho, E. J. and Buratowski, S. (2009). Phosphorylation of the yeast Rpb1 C-terminal domain at series 2, 5, and 7. *Journal of Biological Chemistry*, 284(39): 264-271.
- Roossinck, M. J (2013). Plant Virus Ecology. *PLoS Pathology*, 9(5): 134-139.



## EFFECT OF EGG WEIGHT AND HATCH WEIGHT ON GROWTH PERFORMANCE AND LINEAR BODY MEASUREMENTS OF FULANI ECOTYPE CHICKENS

Falowo , O. A., Y. Sulaiman., Ayoola, A., Adama, T. Z., Egena, S.S.A., Banjo\*, A.A

Department of Animal Production, Federal University of Technology, Minna,  
Niger State, Nigeria

\*Corresponding Author's E-mail: [banjo.adenike@futminna.edu.ng](mailto:banjo.adenike@futminna.edu.ng) GSM: 08027535481

### ABSTRACT

*The study was conducted to determine the effect of egg weight and hatch weight on growth performance and linear body measurements of Fulani ecotype chicken. A total of 320 eggs were used for this study. The birds were divided into 3 equal groups according to their hatch weight. T1 were chicks of weight 0- 25 g, T2 were chicks of 26 – 30 g while T3 were chicks of 31 – 35 g of weight. Egg weight, hatch weight, body weight, body weight gain and linear body measurements such as body length, body girth, wing length, shank length and thigh length. Linear body measurements were measured at the end of week 4, 8 and 12 of the experiment. Positive and significant ( $p < 0.0001$ ) correlation was observed between egg weight and hatch weight. Overall birds hatched from egg weighing 31 – 35g (T3) had better ( $P < 0.05$ ) mean body weight (269.84 g) followed by those hatched from eggs weighing 26 – 30 g (T2) with a mean body weight of 257.78 g. The overall body weight gain from week 1 -12 was significantly ( $p < 0.05$ ) affected by the hatch weight of the chickens with chicks hatched from egg weighing 0 – 25 g (T1) having the lowest (37.22 g). There were positive and significant ( $p < 0.05$ ;  $p < 0.01$ ) correlation between hatch weight and body weight, body length, wing length and shank length at the 4<sup>th</sup> week of the experiment. There were positive and significant ( $p < 0.05$ ) correlation between hatch weight and body weight, shank length and thigh length at the 8<sup>th</sup> week. Also a significant and positive ( $p < 0.05$ ;  $p < 0.01$ ) correlation between hatch weight and body weight, wing length, shank length was observed at the 12<sup>th</sup> week of the experiment. It was concluded from the result that the correlation between egg weight and hatch weight is significant and positive. It was recommended that the better the hatched weight the better the body weight and body weight gain.*

**KEYWORDS:** Fulani, Ecotype, Chicken, eggs, hatching

### INTRODUCTION

Indigenous chickens are raised in most of the developing countries regardless of the traditions, climate, life standard or religious taboos (Tadelle, 2003). Indigenous chickens in Africa are hardy, survive on little or no inputs and adjust to fluctuations in availability of feed. The indigenous chickens are part of 80% of one hundred and twenty million type of poultry raised in the rural areas of Nigeria (Ajayi, 2010). Fulani ecotype chicken is native to the Fulani tribe in the Northern parts of Nigeria which are superior in live weight than any other type of ecotype chicken in Nigeria (Olawunmi., 2008). Egg weight is one of the chief determinant factors required for satisfactory hatching of chickens while hatch weight is used as an indicator for chicks development (Meijerhof, 2005). Smaller egg size tends to hatch earlier and leads to smaller hatched chicks than the standard eggs while extra-large egg size tend to hatch later. Selection of moderately size eggs for poultry

breeding is suggested (Atteh, 2004). There is, thus, scarce information on the relationship between egg and hatch weight with growth parameters particularly of the Fulani ecotype chicken. Therefore, the objective of this study was to determine the effect of egg weight and hatch weight on growth performance and linear body measurements of Fulani ecotype chicken.

### METHODOLOGY

The experiment was carried out at the Teaching and Research Farm of the Federal University of Technology, Minna, Niger State. Three hundred and twenty (320) eggs were collected from the Fulani Ecotype Chickens that were raised on semi-intensive system of management from different Fulani settlement in Niger State. The eggs were numbered and weighed. The eggs were later sent to a standard commercial hatchery in Ibadan for incubation. After the eggs were set in the incubator, fumigation of the incubator and the eggs were done with potassium

permanganate (KMnO<sub>4</sub>) and formalin for 20 mins. The incubator was set at a temperature of 38.5<sup>o</sup> C and relative humidity of 85 %. On the 17 day of incubation, all eggs were candled and those with evidence of living embryos transferred from the turning trays to hatcher basket. At hatching, the chicks were weighed using an electronic scale (SF- 400) to know the hatched chick weight. They were tagged at the winged web and later transferred back to Minna where they were brooded together for a week before been separated based on their hatch weight.

**Data collection:** The egg weight, hatch weight, body weight, body weight gain and linear body measurements were measured. Data on the effect of egg weight and hatch weight on growth performance and linear body measurements of Fulani ecotype chicken was analyzed using Excel and Duncan Multiple Range Test which was used to separate the means. Correlation of analysis was done using the same software.

## RESULTS AND DISCUSSION

Correlation between egg weight and hatch weight of Fulani Ecotype chicken is positive and significant (P>0.001). Hatch weight was significantly (P<0.05) influenced by body weight. Chickens hatched from eggs weighing 0 – 25 g had lower body weight at the first six weeks while those eggs hatched at 31- 35 g had better (P<0.05) body weight. Hatch weight was significantly affected by body weight and body weight gain. However, chickens hatched from eggs weighing 0- 25 g, 26 – 30 g and 31 – 35 g were not found to be significant with body weight gain at 2, 4, 5, 7, 9, 11 and 12 weeks. Meanwhile, the overall body weight gain from week 1 -12 was significantly (P<0.05) affected by the hatch weight of the chickens with chicks hatched from eggs weighing 0 - 25 g had the lowest weight.

There were positive and significant (P<0.05) correlation between hatch weight and body weight, shank length and thigh length in week 4, 8 and 12. Meanwhile, there are positive but not significant (P>0.05) correlation between hatch weight and body girth in week 4 and 8 and only positive correlation between hatch weight and body weight, wing length, shank length and thigh length in week 8.

The egg weights used in the present study ranged from 0- 35 g. Correlation coefficients show the power of linear relationship between the characters and thus provide valuable information about the characters involved for the purpose of breeding and improvement plan. Egg weight had significant positive correlation with hatch weight of Fulani ecotype chicken. This is in line with what was

reported by Nahm (2001) and Abiola *et al.*, (2008) that small chicks hatch from small eggs while large chicks hatched from large eggs in Anak broiler breeders, thus, there are strong and positive correlation between pre- incubation egg weight and hatch weight. Hatch weight significantly influenced the body weight of Fulani ecotype chickens from week 1 – 12. Chicks that have the hatched weight of 31 – 35 g have the best mean body weight (269.84 g) in this study followed by chicks of hatch weight 26 – 30 g (257.78 g). This is not in agreement with Farook *et al.*, 2001, who found a negative correlation between egg weight and hatchability in crossbred chickens. As shown in their studies, heavier eggs tended to result in lower hatchability. On the other hand, heavier chicks at hatching were also observed to have better weight gain. Taking this further might also mean that feed intake is being improved by the size of chick at hatching. Results of the present study indicate that large – sized eggs produced chicks with higher chicks hatch weight than medium and small-sized eggs. This observation is expected since it is known that there is a strong and positive correlation between egg size and chick hatch weight in chickens (Abiola *et al.*, 2008).

Correlation between hatch weight and body measurements of Fulani ecotype chicken at 4, 8 and 12 shows that they're significant and positive. The correlation between the mentioned parameters and hatch weight shows that relationship exists between them. So improvement of hatch weight can be used to improve any of the body measurements as an increase in hatch weight is expected to lead to a corresponding increase in body weight and the measured linear body measurements.

## CONCLUSION AND RECOMMENDATIONS

The range of egg sizes used in this study had a significant effect on fertility rate and hatchability of Fulani ecotype chickens. However, large sized eggs produced chicks with higher hatch-weight than medium and small – sized eggs.

It is recommended that eggs of Fulani ecotype chickens of big size should be set for hatching. Heavy and medium size day old chickens of Fulani ecotype chickens are recommended for rearing because they tend to have higher feed intake, body weight, body weight gain and better feed conversion ratio.

**Table 1: Correlation between egg weight and hatch weight of Fulani ecotype chickens**

	Ew
Ew	1.000
Hw	0.874***

**Table 2 Effect of hatch weight on body weight (g) of Fulani ecotype chickens**

	T1	T2	T3
1	40.57b± 1.96	52.93a± 1.34	57.00a± 1.64
2	52.00b± 3.57	69.07a± 2.44	70.90a± 2.99
3	74.00b± 6.43	99.13a± 4.07	97.40a± 4.98
4	104.17b± 8.28	126.87a± 5.23	126.20a± 6.41
5	140.67± 11.73	166.73± 7.42	166.80± 9.08
6	172.17b±16.22	212.00a± 10.26	218.20a± 12.56
7	218.17b± 20.86	264.20ab±13.19	276.90a± 16.16
8	264.80b± 25.00	322.86ab± 0.04	340.89a± 18.64
9	316.40b± 29.35	379.43ab± 17.54	400.44a± 21.87
10	380.00b± 31.50	430.71ab± 18.83	471.56a± 23.48
11	429.00b±35.16	493.79ab± 21.01	530.22a± 26.20
12	474.60b± 37.14	533.71ab± 22.19	578.89a± 27.68
1- 12	206.19b± 20.38	257.78a±12.80	269.84a± 15.79

Key: a, b, ab means with different superscripts are significantly different, SEM: standard error of mean, FEC: Fulani Ecotype Chicken, T1: chicks hatch from egg weighing 0- 25 g, T2: chicks hatch from eggs weighing 26- 30 g, T3: chicks hatch from eggs weighing 31- 35 g

**Table 3 Correlation between hatch weight and body Measurements of Fulani ecotype chicken at week 4**

	HW	BW	BL	BG	WL	SL	TL
HW							
BW	0.372*						
BL	0.470**	0.808***					
BG	0.18	0.689***	0.552**				
WL	0.452*	0.831***	0.679***	0.599***			
SL	0.417*	0.810***	0.694***	0.458**	0.738***		
TL	-0.394	0.128	-0.015	0.053	0.086	0.117	

key: HW =Hatch weight, BW= Body weight, BL= Body length, BG= Body girth, WL = Wing length, SL= Shank length, TL= Thigh length.

\*significant at p<0.05, \*\*significant at p<0.01, \*\*\*significant at p<0.001



**Table 4 Correlation between hatch weight and body measurements of Fulani ecotype chicken at week 8**

	HW	BW	BL	BG	WL	SL	TL
HW							
BW	0.519*						
BL	0.241	0.678***					
BG	0.185	0.646**	0.446*				
WL	0.147	0.587**	0.244	0.502**			
SL	0.432*	0.803***	0.493**	0.614***	0.565**		
TL	0.497*	0.809***	0.369*	0.481**	0.624***	0.697***	

key: HW =Hatch weight, BW= Body weight, BL= Body length, BG= Body girth, WL = Wing length, SL= Shank length, TL= Thigh length.

\*significant at  $p < 0.05$ , \*\*significant at  $p < 0.01$ , \*\*\*significant at  $p < 0.001$

**Table 5 Correlation between hatch weight and body measurements of Fulani ecotype chicken at week 12**

	HW	BW	BL	BG	WL	SL	TL
HW	1						
BW	0.534**						
BL	0.304	0.804***					
BG	-0.154	0.474*	0.460*				
WL	0.468*	0.867**	0.670**	0.283			
SL	0.499*	0.871**	0.785**	0.339	0.782**		
TL	0.594*	0.736**	0.609*	0.026	0.667**	0.702**	

key: HW = Hatch weight, BW= Body weight, BL= Body length, BG= Body girth, WL = Wing length, SL= Shank length, TL= Thigh length.

\*significant at  $p < 0.05$ , \*\*significant at  $p < 0.01$ , \*\*\*significant at  $p < 0.001$

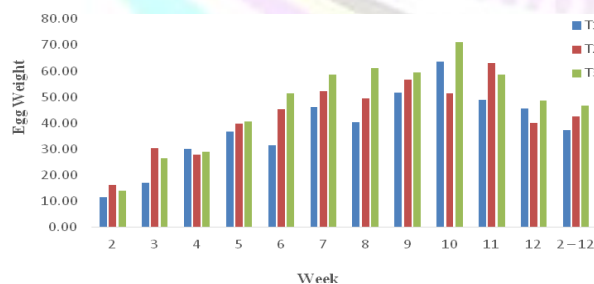


Figure 1: Effect of hatch weight on body weight gain (g) of Fulani ecotype chicken

## REFERENCES

- Abiola, S. S., Meshioye, O. O., Oyerinde, B.O and Bamgbose, M. A. (2008). Effect of egg size on hatchability of broiler chicks. *Arch Zootech.*, 57: 83 – 86
- Ajayi, F. O. (2010). Nigerian Indigenous Chicken: A valuable Genetic Resource for Meat and Egg production. *Asian J. Poult. Sci.* 4: 164 – 172.
- Atteh, J. O (2004). Theory and Practice of Poultry Production. World Scientific News 2016: 53(3), 343 – 353.
- Farooq, M., Mian, M. A., Murad, A., Durrani, F.R., Asghar, A and Muqarrab, A. K., (2001b). Egg traits of Fayumi birds under subtropical conditions. *Standard Journal of Agriculture* 17(2): 141 – 145.
- Meijerhof, R. (2005). What counts for chick quality? Hybro B.V.P.O.Box 30, 5830 A.A Boxmeer, The Netherlands. <http://www.hybro.com>.
- Nahm, K. H., (2001). Effects of storage length and weight loss during incubation on the hatchability of ostrich eggs (*Struthio camelus*). *Poultry Science* 80: 1667 – 1670.
- Olawunmi, O.O., Salako A. E., and Afuwape, A. A. (2008). Morphometric differentiation and assessment of function of the Fulani and young ecotype indigenous chickens of Nigeria. *International Journal of Morphol.* 26 (4): 975 – 980.
- Tadelle, D. S (2003). Phenotypic and genetic characterization of local chicken ecotypes in Ethiopia. PhD thesis, Humboldt - University in Berlin, Germany.

## FACTOR ANALYSIS OF FARO 44 TECHNOLOGIES ADOPTION AMONG FARMERS UNDER FADAMA III AF IN NIGER STATE, NIGERIA

Ibrahim<sup>1</sup>, M. and Mohammed<sup>1</sup>, U. S.

<sup>1</sup>Department of Agricultural Extension and Rural Development, Federal University of Technology, Minna, Niger State, Nigeria

<sup>1</sup>Department of Agricultural Economics and Farm Management, Federal University of Technology, Minna, Niger State, Nigeria

gausubrahama@yahoo.com 0806 5725 897

### ABSTRACT

*Non Strictly adherence of technological package led to low turnover among fadama users' groups. The strictly adherence of the package is expected to increase farmer's income and improve their standard of living. The study therefore examines factor analysis of FARO 44 adoption among fadama users group. A multistage sampling technique was used to select 336 fadama III AF famers from three agricultural zones. Validated questionnaires with reliability coefficient of 0.76 were used to elicit data. Data collected were analyses using adoption scale and factor analysis as well as frequency and percentages. Majority (64.3%) of male were within the active age of (19-36years); married (98.2%); with farming experience of 16-20 years having 0.5-1ha of rice plot while only (41.7%) of their female counterpart were in this category; majority (92.3%) of female respondents were married with only few (12.0%) had farming experience of (16-20years). Technologies such as improved seed (FARO 44)  $\bar{x}=4.0$ ; recommended spacing (20cm by 20cm)  $\bar{x}=3.8$ ; seed per hole (3-4 seed)  $\bar{x}=3.0$ ; use of granular fertilizer ( $\bar{x}=3.9$ ) were production technologies adopted by male respondents. Processing technologies adopted by male were only threshing ( $\bar{x}=3.7$ ) and bagging ( $\bar{x}=3.8$ ) while for female respondents false bottom ( $\bar{x}=3.2$ ) and destoner ( $\bar{x}=3.8$ ) was adopted. For storage technologies male respondents adopted jute bags ( $\bar{x}=3.4$ ); rhombus ( $\bar{x}=3.2$ ) and silos ( $\bar{x}=3.0$ ) while for female respondents was only jute bags ( $\bar{x}=3.0$ ) because it is cheaper and easy to handle. Factor constraining adoption were communication gap between farmers and facilitators (agein value=0.796); untimely delivery of inputs (agein value = 0.783); transplanting too tedious (agein value= 0.413); high cost of false bottom (agein= 0.486). It was concluded that majority of the technologies were at evaluation and trial stage for both male and female respondents. It was recommended that communication process needed to be strengthened.*

**KEYWORDS:** Fadama, rhombus and FARO

### INTRODUCTION

"FADAMA" Is a Hausa name for irrigable land-usually low-lying plain underlay by shallow aquifers found along Nigeria's major rivers system. The fadama III Additional Financing a collaborative project of the world bank Federal and State Government has been of immense benefit to farmers in Niger State. The project has greatly enhanced the capacity of farmers, increased their income, boosted their economy and made life more worthy of living (Ibrahim, 2016). Niger State has implemented World Bank/FG assisted project under the agricultural sector namely Bida Agricultural Development Project, Multi-State Agricultural Development Project, National Agricultural Technology Support Project, fadama I and II, III and Presently implementing fadama III AF which have helped to develop farmers-managed irrigation scheme.

Rice has long become a staple food in the Nigeria food chain. Nigeria no doubt, has natural endowment to be self-sufficient in rice production in less than 5years but has been impeded all long by conflicting policies and import waivers which permitted large foreign owned rice processing mills to import brown rice from South East Asia there by exporting badly needed jobs to those countries of import and increasing unemployment locally. Farming is not just an option to us in Niger State but a necessity, considering the vast fertile land and other resources, the state can feed the entire West Africa (Ibrahim, 2016).

The most important determinants of the effectiveness of research results is the level of adoption of innovation that it generates, and on their profitability (Caswell, 2001). In addition, the faster the research can be completed, the higher the turnover of benefits.



Moreover, the more evidence research results are, the easier it is to justify the implementation of and continues investment in research programmes. A common problem for many individual and organization is how to speed up the rate of diffusion of a research program's innovations (Roger, 1995). The main objective of the study is to examine the factor analysis of FARO 44 adoption of *fadama* users group (FUGs).

The Specific Objectives are to: describe the socio-economic characteristics of the *fadama* user groups; examine factor analysis of FARO 44 adoption level among beneficiaries; identify constraining factors hindering adoption of FARO 44 adoption.

## METHODOLOGY

The study was conducted in Niger State Nigeria. Out of twenty-five local governments that made up the state, three local governments namely Katcha (Zone 1), Shiroro Zone (II) Wushishi (III) were purposively selected for the study. Their selection were based on the preponderance of Fadama User Groups (FUGs). Multi-stage sampling techniques were adopted for the study. In the first stage two (2) production clusters were selected from each of the zones. In the second stage seven (7) production groups were randomly selected from each of the production cluster and finally four (4) female and four (4) male were interviewed from each of the production groups. This gave a total of 336 respondents. Data were collected from the respondents using structured interview scheduled. Data collected were analyze using descriptive statistics like mean, percentages. Adoption scale analysis was employed to analyses the level of adoption of FARO-44 technologies. Seven point likert scale was adopted to ascertain level of adoption. The scale are as follows; un aware (0), aware (1), interest (2), evaluation (3), trial (4), accept (5), reject (6).

Each item will therefore be computed by multiplying the frequency of each response pattern with its appropriate nominal value and dividing the sum with the number respondents to the item. This is summarized with equation below.  $XS = \sum \frac{fn}{nr}$

Where XS= Mean score

$\sum$ = Summation

f=frequency

n= likert nominal value

nr= number of respondents

Any respondents that had means score of three (3) or greater than mean score is said to adopt FARO 44 Technology for that item while any score below three (3) is said to reject the technology in question.

Factor analysis procedure using factors with varimax rotation. The constraints were grouped using principal component analysis with iteration and varimax rotation method developed by Kaiser 1958. The cut-off point constraint loading was within the range of 0.3-0.5. variables that load in more than one constraint will be discarded following Akinnagbe (2013) and Ibrahim (2016).

The Model is presented in equation..... (1)

$$Y_1 = a_{11}X_1 + a_{12}X_2 + \dots + a_{1n}X_n$$

$$Y_2 = a_{21}X_1 + a_{22}X_2 + \dots + a_{2n}X_n$$

$$Y_3 = a_{31}X_1 + a_{32}X_2 + \dots + a_{3n}X_n$$

\* \* \* \* \*

$$Y_n = a_{n1}X_1 + a_{n2}X_2 + \dots + a_{nm}X_n$$

Where;

$Y_1, Y_2, \dots, Y_n$  = Observed variable/ constraints to linkage / practice

$a_1 - a_n$  = Constraints to correlation coefficients;

$X_1, X_2, \dots, X_n$  = Unobserved underlying factors constraining linkage practice

## RESULTS AND DISCUSSION

Table 1. Shows that (64.3%) of male were within the age bracket of 19-36years which is active stage of life which make it possible to withstand the rigor associated with the farming activities while only (41.7%) of the female counterpart were within that age bracket. About 62.5% of the male respondents had secondary education while only 30.4% of the female counterpart had same. This means that most of the female respondents were not allowed to continue with their secondary education because of marriage. More so. About 83.4% of male respondents had farming experience of 11-20years while only 32.8% of the female counterpart had same. This implies that with more experience in farming activities, farmers become less averse to the risk. All (100%) respondents were a member of one cooperative or the other this was plausible because the sample of the respondent were drawn from

production clusters. Almost all 98% of the two categories of the respondents cultivated one hectare of land, this may probably be as a results of the *fadama* III AF package. Majority (68.5%) of male respondents had the house hold size of 6-10 persons while only (35.7%) of their female counterpart had same, this disparity may probably be because of the polygamy been practice in most of the rural farm families in the rural communities. Effiong (2005) reported that a relatively large house hold size enhances the availability of labour. Majority of the respondents cultivate 1ha. This implies that adoption cost, risk perception labour requirement and human capital requirements are definitely reduced.

Level of FARO 44 adoption technologies. The results show that recommended improve rice seed had the highest frequency of adoption (93) for the male famers with the mean ( $\bar{x}$  = 4.0) followed by recommended spacing of 20cm by 20cm (66) with the mean of (3.8) This means that male respondents want to optimized the space and maximized outputs. Recommended quantity of granular fertilizer application had (79) with the mean value of ( $\bar{x}$ =3.9). This implies that respondents attach value to granular fertilizer than any other production inputs in the study area apart from improve rice seed. This may probably attributable to the fact the role fertilizer plays in increasing the output of the farmers.

Furthermore, seed per hole had only (43) by male respondents with the mean of ( $\bar{x}$ =3.0). This depict that with the minimum number of seed per hole, the rice plant stands the chance of tillers while only (10) of their female counterpart tried seed per hole with the mean value of ( $\bar{x}$ =2.7). This means that female respondents are not willing to adopt seed per hole as a technology.

Water management had (58) with the mean value of ( $\bar{x}$ =3.6). This attributable to the fact that rice is water loving plant. Harvesting method had mean value of ( $\bar{x}$ =3.1). this mean that timely harvest reduces loss while for female respondents, improved seed, transplanting, recommended spacing, and water management had the mean value of 3.4, 3.1, 3.8 and 3.1. this means that only four out of 17 production technologies were adopted by the female respondents.

For the processing technologies (75) of the female were at evaluation stage in term of false bottom usage with the mean of ( $\bar{x}$ =3.2) while only (25) of their

male counterpart were in this stage. De-stoner had (80) adoption with the mean value of ( $\bar{x}$ =3.8) while only 18 of their counterpart were in this category. This implies that females were more interested in trying processing technologies then their male counterpart in the study area. This may probably be because, processing of agricultural product is purely a woman job. But for bagging male were at adoption stage with mean of  $\bar{x} = 3.8$ .

Storage technologies, Jute bag was the only storage technology adopted by both male and female. with the mean of ( $\bar{x}$ =3.4) and ( $\bar{x}$ =3.0) respectively. This may probably be because it is cheaper and lighter for handling. Rhumbus had mean value of ( $\bar{x}$ =3.2) for male respondents. The technologies that suffer set back from female respondents in term of rejection were post emergence herbicide with the mean value ( $\bar{x}$ =1.9), liquid fertilizer (1.8%), puddling and bunding (1.2). These to them were not effective and may be additional cost if put in use. In conclusion that female farmers were receptive to processing technologies although male respondent accept most of technologies than their female counterpart. Generally, the finding depict that majority of the technologies were at evaluation and trial stage for both male and female respondents.

I.S (Improve seed) 25kg of FARO 44/ha; T.P (Time of planting) (June) D. P (Depth of planting) 3-4cm T.D (Touch down) (pre-emergence herbicide) S (Solito) (post emergence herbicides); R.S (Recommended spacing) 20cm by 20cm SPH (Seed per hole) 4-5 seed P. B (Puddling and bonding FAG (Fertilizer application "granular") first dose (NPK 15: 15: 15: 4 bags); FA (Fertilizer application) second dose (Urea 46:0:0 2bags); W.C (weed control measure) MBS (Methods of bird scaring) WM (Water management) FA (Fertilizer application) "liquid" first dose (NPK 2liters, Boron 2liters; FA (Fertilizer application second dose (Urea liquid 2liters); H. (Harvesting) R. (Recoup) 25%

### Processing Technologies

T (Threshers) UFB (Use of False bottom) for per boiling; DS. (Drying slabs) D. (De-stoner) MG. (Measurement gauge)B. Bagging.

### Storage Technologies

23. JB (Jute bag) R. (Rhumbus) WH (Ware house) Sale 85% to off takers.

### **Factors analysis constraining adoption of FARO 44 among respondents**

Table 4. Showed factor matrix on adoption constraints. Factors base on variable loading were used; four factors were identified and named. Factor one (1) were economic related factors, (2). policy related factor; cultural related factors (3) and attitude related factors (4). Items that loaded high in factor 1, (economics related constraints), included Poor relationship between farmer/facilitator and desk officers (agein value=.373); Poor monitoring and evaluation (agein value =.327); Difficulty in raising counterpart fund (agein value=.354); In ability to recoup 25% of the total harvest (agein value=.301); Farmers cum hersdmen clash (agein value = .302), High cost of false bottom (agein value=.486); Items that loaded high in factor 2, (policy related constraints), is Untimely delivery of inputs (agein value= .783). while for cultural related factors were; Transplanting is too tedious (agein value= .413); poor saving culture (agein values.335); while for attitude related factors are wide commutation gap between the famers and facilitators (agein values.796) and Liquid fertilizer not effective (agein values.460).

### **CONCLUSION AND RECOMMENDATIONS**

It was concluded that male farmers attached more value to production technologies than processing technologies while female respondents adopted most of the processing technologies than production technologies. More so recommended spacing of 20cm by 20cm had the highest percentage (74%) of adoption from the male respondents while solito (post emergence herbicide) had the highest percentage (28%) of rejection from female respondents. It was concluded that majority of the technologies were at evaluation and trial stage for both male and female respondents. It was recommended that communication process needed to be strengthened.



Table 1: Distribution of respondents according to socio-economics characteristics n=336

Socio-economics characteristics	Male		Female		Pooled	
	F	%	F	%	F	%
<b>Age (years)</b>						
1-18	-	-	3	1.8	3	0.9
19-36	108	64.3	70	41.7	178	53.0
37-54	50	29.8	90	53.6	140	41.7
>54	10	6.0	5	3.0	15	4.5
<b>Marital status</b>						
Single	3	1.8	5	3.0	8	2.4
Married	165	98.2	155	92.3	320	95.2
Separated	-	-	4	2.3	4	1.2
Divorce	-	-	4	2.3	4	1.2
<b>Educational level</b>						
No schooling	3	1.8	25	14.9	28	6.0
Primary	55	32.7	90	53.6	145	43.1
Secondary	105	62.5	51	30.4	156	46.4
Tertiary	5	3.0	2	1.2	7	2.1
<b>Membership of cooperative</b>						
Member	168	100	168	100	336	100
Non-member	-	-	-	-	-	-
<b>Farming experience</b>						
<5	-	-	7	4.2	7	2.1
5-10	20	11.9	89	53.0	109	32.4
11-15	50	29.8	35	20.8	85	25.3
16-20	90	53.6	20	12.0	110	32.7
21-25	6	3.6	15	9.0	21	6.3
26-30	2	1.2	2	1.2	4	1.2
<b>Farm size</b>						
0.5-1.0	165	98.2	166	98.8	331	98.5

1.1-1.5	3	1.8	2	1.2	5	1.4
<b>House hold size</b>				-		-
0-5	50	29.8	105	62.5	155	46.1
6-10	115	68.5	60	35.7	175	52.0
11-15	3	1.8	3	1.8	6	1.8
>15	-	-	-	-	-	-
<b>Occupation</b>						
Full time famer	165	98.2	128	98.2	293	87.2
Part time farmer	3	1.8	40	23.8	43	12.8

Source; Field Survey; 2017

Table 2: Frequency distribution of male and female respondents by stages of adoption of FARO 44 rice production, processing and storage technologies. Tables well-presented look beautiful

TEC	Unaware		Aware		Interest		Evaluation		Trial		Adoption		Rejected		Adoption Mean Score	
	M	F	M	F	M	F	M	F	M	F	M	F	M	F	M	F
IS	0	0	12	19	20	38	13	25	30	32	93	54	0.0	0.0	4.0	3.4
TP	12	0	25	29	26	26	25	43	50	41	30	29	0.0	0.0	2.4	3.1
DP	31	0	35	25	37	39	30	53	35	30	0.0	21	0.0	0.0	2.0	2.9
TD	0	0	30	15	25	25	20	22	44	25	49	44	0.0	0.0	3.3	2.7
S	45	36	38	45	27	29	33	44	20	14	5	0.0	0.0	0.0	1.8	1.9
RS	0	0	7	6	20	15	35	45	40	35	66	67	0.0	0.0	3.8	3.8
SPH	0	0	45	58	25	35	27	25	28	20	43	10	0.0	20	3.0	2.7
PB	45	50	54	60	25	30	24	28	20	0.0	0.0	0.0	0.0	0.0	1.4	1.2
FAG	0	0	12	30	17	25	25	45	35	33	79	35	0.0	0.0	3.9	3.1
FAS	0	0	35	45	47	44	42	37	25	27	19	15	0.0	0.0	2.7	2.5
WCM	0	45	35	40	27	33	47	22	33	28	26	0.0	0.0	0.0	2.9	1.7
MBS	45	40	35	25	25	37	20	27	15	19	28	20	0.0	0.0	2.1	1.5
WM	0	0	15	17	25	47	30	38	40	34	58	32	0.0	0.0	3.6	3.1
FAL	0	38	45	40	40	39	30	27	23	24	10	0.0	20	0.0	2.6	1.8
FAS	0	44	55	36	45	45	25	21	10	22	13	0.0	20	0.0	2.3	1.6
H	0	45	35	38	28	40	45	32	33	13	7	0.0	20	0.0	3.1	1.7
R	0	32	35	41	45	34	37	27	31	34	20	0.0	0.0	0.0	2.7	1.9

### Processing Technologies

T	0	0	25	29	15	35	25	82	20	12	83	10	0.0	0.0	3.7	2.4
FB	45	0	25	20	35	15	15	75	25	35	10	23	13	0.0	2.2	3.2
DS	42	0	35	35	25	25	27	70	19	20	20	18	0.0	0.0	2.0	2.3
D	30	0	45	15	25	18	30	25	20	30	18	80	0.0	0.0	2.1	3.8
MG	0	0	45	47	35	40	25	33	20	19	15	17	28	12	2.9	2.6
B	0	0	12	55	18	25	25	35	45	28	68	15	0.0	10	3.8	2.4

### Storage Technologies

JB	0	0	27	30	29	38	15	37	37	30	60	33	0.0	0.0	3.4	3.0
R	0	0	20	38	35	20	32	30	43	45	38	35	0.0	0.0	3.2	2.6
WH	30	30	35	25	30	28	20	20	25	18	18	20	10	27	2.4	2.8
S	30	38	25	20	20	26	15	22	30	29	20	19	28	14	3.0	2.5

Source; Field survey, 2017

Where;

TEC= Technologies ranging from 1-26

Production Technologies

Table 3: Factors constraining adoption of FARO 44 technologies (0.30)

Variables	Factor 1	Factor 2	Factor 3	Factor 4	Rank
Business plan not in line with farmers demand	-	-	-.032	.025	D
Poor relationship between farmer/facilitator and desk officers	.373*	.134	.242	.040	S
Poor monitoring and evaluation	.327*	.109	.282	.204	S
Wide Communication gap between the famers and facilitators	.149	.035	.065	.796*	S
Untimely delivery of inputs	.161	.783*	.039	.077	S



Germination percentage is low	-.431*	.041	.192	.042	S
Difficulty in raising counterpart fund	-.354*	.020	.204	.045	S
Liquid fertilizer not effective	-.079	.050	.045	.460*	S
Transplanting is too tedious	.164	.066	.413*	.158	S
Insufficient rain fall	-.066	-	-.126	-	D
Problem of qualee bird	.014	-	.163	-	D
Incidence of gall midge	.175	-	.168	-	D
Problem of iron toxicity	.290	.0665	.107	-.145	NS
In ability to recoup 25% of the total harvest	.301*	.261	.061	-.032	S
Low pricing by the off takers	.080	.049	.159	.007	NS
Language barrier	.025	.103	.060	.298	NS
Poor saving culture	.103	.055	.335*	-.137	S
Farmer cum herdsman clash	.302*	.079	.078	.058	S
High cost of milling machine	-	.276	-	.007	D
High cost of threshers		.032	.717	-	D
Incidence of rodents in the store	.032	.297	.043	.014	NS
Wrong view of famers incapable of taking rational decision	.080	-.303	.065	.239	NS
High cost of false bottom	.486*	.0400	.163	.107	S

Key: D= Discarded, S=Significant NS= Not significant

Method: Principal Component Analysis.

Rotation Method: Varimax with Kaiser Normalization.

\*Sig

Extraction

- overlap

Field Survey, 2017

## REFERENCES

Akinnagbe, O.M. (2010). Constraints and strategies towards improving cassava production and processing in Enugu North Agricultural Zone of Enugu State, Nigeria. *Bangladesh Journal of Agricultural Recourses*, 35 (3): 387-397.

Ibrahim. M. (2016). Good Agronomic Practice for Rice Production Cluster. Niger State Fadama Coordination Unit. Technical report of Louma Rice Production Cluster. Pp 36. [www.nigerfadama.co.uk](http://www.nigerfadama.co.uk).

Ibrahim. M. (2016). Best Practice for Rice Production. Niger State Fadama Coordination Unit. Technical report of Tukurji Rice Production Cluster. Pp 39. [www.niger@fadama.net](http://www.niger@fadama.net)

Ibrahim. M. (2016). Linkage Practice Among Agricultural Research Institute and Universities for Agricultural Innovation Transfer in North Central Nigeria. Unpublished Ph.D Thesis. Submitted to the Department of Agricultural Extension and Rural Development. University of Ilorin Kwara State. Nigeria. Pp145

Casswell, K. Fuglic., C.Ingram., S. Jans., C. Kasca (2001). Adoption of Agricultural Production Practice: lesson learnt from the U.S, Department of Agriculture area studies Project. WashintongsDC. US Department of Agriculture. Resource Economics Division, Economics Research service. Agricultural Economics report NO. 792, January,2001

Effiong. E.O. (2005). Efficiency of production in livestock enterprise in Akwa. Imo State. Nigeria. Unpublished Ph.D Dissertation. Department of Agricultural Economics. Micheal Okpara University of Agriculture, Umudike. Pp167.

# AGRONOMIC PERFORMANCE OF CHICKPEA (*CICER ARIETINUM* L.) VARIETIES UNDER VARIED PHOSPHORUS LEVELS AT EJERSA LAFO DISTRICT, WEST SHOWA ZONE, CENTRAL ETHIOPIA

Chala Chalchissa<sup>1</sup>, Habtamu Ashagre<sup>2</sup>, Ibrahim Hamza<sup>3\*</sup>

<sup>1</sup>Ethiopian Institute of Agricultural Research, Ambo Plant Protection Research Center, Ambo, Ethiopia

<sup>2</sup>Ambo University, College of Agriculture and Veterinary Sciences, P.O.Box 19, Ambo, Ethiopia

<sup>3</sup>Federal University of Technology Minna, Department of Crop Production Technology, School of Agriculture and Agricultural Technology, Corresponding Author E-mail Address: haiayi@yahoo.com

## ABSTRACT

Chickpea is one of the most important staple pulse crop cultivated in Ethiopia. However, its productivity is constrained by a number of factors, out of which fertilizer rates and varieties are the most important ones. Therefore, a field experiment was conducted in 2016 cropping season to determine the performance of different chickpea varieties under varied phosphorus levels in Ejersa Lafo district, West Showa Zone, Central Ethiopia. Treatments consisted of a factorial combination of four chickpea varieties (Dalota, Teketay, Natoli and Local check) and four phosphorus rates (0, 23, 46 and 69 kg P<sub>2</sub>O<sub>5</sub> ha<sup>-1</sup>) arranged in a randomized complete block design with three replications. The results revealed that main effect of both phosphorus rates and varieties were highly significant ( $P < 0.01$ ) on days to 50% flowering, days to 90% maturity, number of primary branches, number of secondary branches, nodule per plant, root length, number of pods per plant and hundred seed weight. Statistically significant interaction effect of phosphorus rates and varieties was recorded for plant height, number of seeds per pod, biological yield, seed yield and harvest index. Significantly high seed yield (2945 kg ha<sup>-1</sup>) and biological yield (7991 kg ha<sup>-1</sup>) were obtained for Teketay variety with the application of 46 kg P<sub>2</sub>O<sub>5</sub> ha<sup>-1</sup>, while the local variety with zero application recorded the lowest seed and biological yield. Optimum net benefits of EB 53703ha<sup>-1</sup> was recorded on Teketay variety with application of 46 kg P<sub>2</sub>O<sub>5</sub> ha<sup>-1</sup>. Therefore, Teketay variety with 46 kg P<sub>2</sub>O<sub>5</sub> ha<sup>-1</sup> fertilizer application was found to be economically beneficial compared to the other treatments and hence suggested for farmers in the study district.

**KEYWORDS:** Fertilizer rates, Chickpea varieties, Grain yield, Net benefit

## INTRODUCTION

Chickpea (*Cicer arietinum* L.) is the third most important pulse crop in the world, after dry bean and field pea. Africa contributes about 3.87% to the global chickpea in terms of area and about 4.9% in terms of production (FAOSTAT, 2014). Ethiopia is also considered as the secondary centre of diversity for chickpea (Yadeta and Geletu, 2002). Chickpea is an important staple pulse crop in Ethiopia, and leads in production and area under cultivation next to faba bean and haricot bean. It is mainly cultivated in the central highlands and some lowlands areas. Oromia National Regional State share 43% from the total national's chickpea in area coverage, and 48%

production (CSA, 2015). The crop contributes 17% of the total pulse production in the country. It provides substantial economic merits for many smallholder farmers as a source of protein for human and livestock. Chickpea also fetches good price when sold in local market and hence generates cash for farmers. Moreover, it is being exported to Asia and Europe contributing positively to Ethiopia foreign exchange earnings. Chickpea served as a break crop since it improves soil fertility through biological nitrogen fixation. The *desi* type of chickpea is the most commonly grown. Chickpea is consumed in different forms such as *kollo* (roasted seed), *nifiro* (boiled seeds), *shiro* and *bukulti* (sprouts) and the



seeds consumed during the green pod stage as a vegetable (MOA, 2011). According to Ejersa Lafo district production annual report (EJDA, 2015) chickpea is the fourth most important crop grown in the district after Teff, wheat and barley, and ranks first from pulses main cropping seasons.

In Ethiopia, the average potential seed yield is estimated to be 1.9 ton ha<sup>-1</sup> (CSA, 2015) which is less than half of the global chickpea production potential (5 ton ha<sup>-1</sup>). In most chickpea growing areas of Ethiopia, the main constraints reported to affect chickpea production includes: lack of high yielding varieties, abiotic (poor soil fertility, drought and extreme temperatures) and biotic (*Ascochyta blight*, *Fusarium wilt* and Pod borer) stresses (Upadhyaya *et al.*, 2011). Lack of improved varieties and poor soil fertility are among the major limiting factors in West Showa Zone and in particular, Ejersa Lafo District (EJDA, 2015). Therefore, the objective of the study was to evaluate the performance of different chickpea varieties under varied phosphorus levels in Ejersa Lafo district.

## METHODOLOGY

### Description of the study area

The study was conducted in Cheleka Bobe kebele, Ejersa Lafo district, West Showa Zone, Oromia National Regional State of Ethiopia in 2016/2017 cropping season. Ejersa Lafo is one of the 22 districts of West Showa Zone, located at about 65 km from Addis Ababa to the Western part of the country, 47 km from Ambo town to the East. The study area is situated at 09°33'412"N, and 038°14'697"E at an altitude of 2154 meters above sea level (m.a.s.l). The soil is predominantly Vertisols (EARO, unpublished) with pH values of 7.15 - 7.6. The study area has a bimodal rainfall pattern, with the main rain from June to September and short rain from February to April. The 2016 year average annual rainfall, maximum and minimum temperatures were 1339.8 mm and, 24.4 and 8.7°C respectively, with 56.4% average RH.

### Treatments and experimental design

The treatments consisted of a factorial combinations of four Desi type chickpea varieties (Dalota, Teketay,

Natoli which are improved varieties and one local cultivar (*Mucha lame*)) with four Phosphorus fertilizer rates (0, 23, 46 and 69 kg P<sub>2</sub>O<sub>5</sub> ha<sup>-1</sup>) which were laid down in a randomized complete block design in three replications. Nitrogen fertilizer in the form of urea was applied as starter dose at the rate of 20 kg N ha<sup>-1</sup> and Triple super phosphate (46 kg P<sub>2</sub>O<sub>5</sub>) as source of phosphate to all the treatments. Seeds were sown in rows with spacing of 10 cm between plants and 30 cm between rows in a 2.4m x 3 m (7.2m<sup>2</sup>) plot. The spacing between plots and blocks were 0.5 m and 1 m respectively. Each plot has 8 rows and the central 4 rows were considered as net plot. The 2<sup>nd</sup> and 7<sup>th</sup> rows of each plot were used for nodule measurement, while the outer most rows on both sides of each plot was considered as border. All improved varieties were obtained from Debre Zeit Agricultural Research Center (DZARC)

### Soil sampling and analysis

A composited initial soil sample before planting was taken at 0-30 cm soil depth from the experimental site. The soil was processed following standard procedures and analyzed in Ambo University Chemistry department laboratory for organic matter content following the procedure Walkley and Black (1934), total nitrogen by the Kjeldahl method (Bremner and Mulvaney, 1982). Soil reaction (pH-H<sub>2</sub>O) using a pH meter with 1:2.5 soil to solution ratio via a glass electrode attached, and Cation Exchange Capacity (CEC) leaching the soil with neutral 1 N ammonium acetate (FAO, 2008). Available phosphorous by Olsen *et al.*, (1954); exchange able potassium by the use of flame photometer. The particle size analysis was done using the hydrometer method as outlined by Anderson and Ingram (1993).

### Agronomic management of the experiment

All agronomic practices were implemented in accordance with the given recommendation of the crop. The experimental field was ploughed by oxen, and land leveling done manually prior to planting. The seed was treated with Apron star before planting on the 15<sup>th</sup> of September 2016. Basal application of Phosphorus was carried out at planting for all plots and treatments. Hand weeding was carried out twice; first weeding at 32 days after sowing (DAS) and the second weeding at 60 DAS. Dimethoate (40 % EC) and Endosulfan (35% EC) at 2 liters per hectare was sprayed for the control of cutworms and pod borer

*Helicoverpa armigera*) respectively during the early growth and pod development stage of the crop. Harvesting and threshing were manually done. The chickpea was cut close to the ground when the foliage, stem and pods color had all changed to golden brown and fully dried.

#### Data collection

Phenological, growth, yield and yield components data were collected. The parameters were days to 50 % flowering, days to 90 % physiological maturity, Plant height (cm), Number of primary branches per plant, Number of secondary branches per plant, Stand count, Nodule and Root length, Number of pods per plant (NPPP), Number of seeds per pod (NSPP), Thousand seed weight (TSW), Biomass yield (BY), Seed yield (SY) and Harvest index (HI).

#### Statistical analysis

All collected data were subjected to analysis of variance (ANOVA) using statistical application software (SAS) version 10 (SAS, 2004) and interpretations were made following the procedure of Gomez and Gomez (1984). Where significant differences exist among treatments, the least significance difference (LSD) test was used for the separation of means. The partial budget analysis technique was applied to determine the cost and benefit of the treatments.

## RESULTS AND DISCUSSION

The soil physico-chemical properties of the experimental site

The result of laboratory analysis of the soil sample showed that the soil textural class is silty clay according to the soil textural triangle classification with 15% sand, 51% silt and 34% clay particle size distribution (Table 1). High clay content in the soil might indicate better water and nutrient holding capacity of the soil. The soil pH of the experimental site was 7.57, which is slightly alkaline (Landon, 1991). Chickpea specifically grows well under the pH range of 6.0 to 8.0 (ICRISAT, 2010). Hence, the soil pH of the experimental site is ideal for chickpea production. The CEC of the experimental soil was 57.38 cmol (+)/kg (Table 1) which lies in the very high range according to Landon (1991) classification.

The soil of the study site had a low organic carbon content based on Netherlands commissioned study by Ministry of Agriculture and Fisheries of Ethiopia (1995) that classify soils with OC contents with (%) >3.50, 2.51-3.5, 1.26-2.50, 0.60-1.25 and <0.60 as very high, high, medium, low and very low, respectively, indicating low potential of the soil to supply N as corroborated by the record total per cent N (0.08%) and available phosphorus which are all in the low category according to Landon (1991) classification. Generally, the soil of the study site can be described as low in fertility which indicates the need for fertilization.

Phenological, growth and yield parameters of chickpea

Days to 50 % flowering and 90 % physiological maturity

The result showed that both days to 50% flowering and days to 90 % physiological maturity were significantly ( $P < 0.01$ ) and ( $P < 0.05$ ) affected by the main effect of varieties and phosphorus rates. The main effect of variety showed that local variety flowered earlier than the three improved varieties as it attain 50 % flowering at 50 days after planting (DAP) (Table 2). Natoli, one of the improved varieties flowered late (56.4 DAP) when compared to Taketay and Dalota. This could be due to varietal differences in their genetic makeup (Addisu, 2013). The main effect of phosphorus also showed that the longest (53.8) number of days to 50 % flowering was recorded with zero P application (control) and the shortest (51.6) with a non-significant difference between 46 and 69 kg  $P_2O_5$  ha<sup>-1</sup> (Table 2). Days to flowering decreased with increment of phosphorus up to 46 kg  $P_2O_5$  beyond which no further increase or change was observed in number of days to flowering. This might be attributed to the association of phosphorus with early maturity of crops. This finding corroborates Brady and Weil (2002) who reported that phosphorus application could decrease days to flowering since it promotes rapid cell division and growth. Tessema and Alamayehu (2015) had also reported that phosphorus is important for flowering and seed formation as well as advances crop maturity.

The analysis of variance for days to 90 % physiological maturity was also significantly ( $P < 0.05$ ) affected by the main effect of chickpea varieties and phosphorus rates. The variety Natoli



matured significantly late with 120.4 days compared to other varieties (Table 2). The shortest (115.3) days to maturity was recorded with the local variety (Table 2). This might be attributed to the inherent genetic difference among the varieties of chickpea and the high variability in adapting to the environment. The main effect of Phosphorus rates indicated that the shortest day to physiological maturity was obtained with application of phosphorus at all levels showing no significant differences and the longest days (120.4) was recorded on the control (Table 2). The probable reason might be that phosphorus hastens maturity of plant. This is in agreement with Dotaniya (2014b) who reported that phosphorus stimulates flowering and hastens maturity.

#### Number of primary and secondary branches per plant

The numbers of primary and secondary branches per plant were significantly ( $P < 0.05$ ) affected by the main effect of phosphorus rates and varieties. The main effect of variety indicated that Teketay produced significantly higher number of primary branches per plant (5.33) than all the other varieties, while the local variety produced significantly higher (14.57) secondary branches (Table 3). Moreover, Natoli variety produced significantly lower number of secondary branches per plant (11.46). Dalota, Natoli and local varieties did not varied significantly among themselves on the number of primary branches per plant (Table 3). All varieties varied significantly among themselves for number of secondary branches per plant. Sarker (2005) had reported a high variability in the number of branches in legumes which is in line with the findings in this study.

The main effect of phosphorus showed that significantly lower (4.34) and higher (5.56) number of primary branches per plant was recorded in control and 46 kg  $P_2O_5$  ha<sup>-1</sup> respectively (Table 3). The mean number of primary branches per plant increased by 18, 28 and 20% for 23, 46 and 69 kg  $P_2O_5$  ha<sup>-1</sup> respectively in comparison with control (Table 3). This might probably be due to the cumulative effect of phosphorus on the processes of cell division and balanced nutrition. Meseret and Amin (2014) reported that application of P significantly increased the branches plant<sup>-1</sup> over control. The number of secondary branches also showed same trend (Table 3). The mean secondary branch was increased by 7,

24 and 10 % with the application of 23, 46 and 69 kg  $P_2O_5$  ha<sup>-1</sup>, respectively when compared to control. Similarly Guriqbal *et al.* (2011) reported that secondary branches per plants of chickpea increases with increasing level of nutrient supply.

#### Root length and Number of nodule per plant

The analysis of variance for root length, showed a highly significant ( $P < 0.01$ ) effect due to the main effect of varieties and phosphorus rate. The highest mean number of root length was recorded for Natoli (14.45) and Teketay (13.94), whereas the lowest was obtained for variety Dalota (13.18) and local variety (13.13) (Table 3). This might be due to the presence of genetic variability. Root length increased significantly with the increase in applied phosphorus rates from zero (control) to 46 kg  $P_2O_5$  ha<sup>-1</sup>, beyond which there was no significant change noticed. Moreover, the longest root length was obtained with 46 kg  $P_2O_5$  ha<sup>-1</sup> (Table 3). It was observed that with incremental supply of phosphorus, there was likely an improvement in available phosphorus in the soil which might have helped improved the root length. This result was in line with the finding of Dotaniya (2014a) who reported phosphorus stimulates early crop root development.

#### Number of nodule per plant

The analysis of variance result of number of nodule per plant indicated a significant ( $P < 0.05$ ) main effect of both varieties and phosphorus rates and a non significant interaction effect. Higher number of nodule per plant (62.48) was obtained for the variety Natoli and least number of nodules per plant (32.08) was recorded for local variety (*Mucha lame*) (Table 3). There was no significant difference observed between Dalota and Teketay varieties. The application of phosphorus also significantly ( $P < 0.05$ ) affected number of nodules plant<sup>-1</sup> (Table 3). Highest (52.38) number of nodules plant<sup>-1</sup> was produced with the application of 46 kg  $P_2O_5$  ha<sup>-1</sup>, while lowest (44.15) number of nodules plant<sup>-1</sup> was recorded from the control. Generally, the number of nodules per plant increased with increment of Phosphorus fertilizer. This might be attributed to the role of phosphorus as an essential element for the development and function of nodules in pulses. This result was in line with the finding of Ripudaman *et al.* (2014) who reported that number of nodules per plant increased with increasing level of phosphorus



significantly up to 50 kg P<sub>2</sub>O<sub>5</sub> ha<sup>-1</sup>. The result also agrees with that of Adissu (2013) who reported that application of phosphorus produced significantly high number of nodules per plant and nodule weight.

#### Nodule dry weight per plant

The dry weight of nodules was significantly (P<0.001) affected by interaction effect of chickpea varieties and phosphorus rate (Table 4). Higher nodule dry weight (7.26 g) was observed at 46 kg P<sub>2</sub>O<sub>5</sub> ha<sup>-1</sup> with Natoli variety, while lower nodules dry weight (2.13g) was observed at control with local variety. The interaction effect shows that Natoli was more responsive to phosphorus application in terms of nodule dry weight at 46 kg P<sub>2</sub>O<sub>5</sub> ha<sup>-1</sup> beyond which a decrease was also observed. This could be due to the genetic makeup of the variety in the use of available phosphate. Phosphorus had been reported to have a stimulating effect on nodule growth and nitrogenase activity in nodules of legumes (Tang *et al.* 2001).

#### Plant height

The analysis of variance showed a significant (P < 0.01) interaction effect of varieties and phosphorus rates on the plant height of chickpea. Significantly taller plants 52.1 and 51.53 cm were obtained for varieties Teketay and local varieties respectively with application of 46 kg P<sub>2</sub>O<sub>5</sub> ha<sup>-1</sup>(Table 5). All P<sub>2</sub>O<sub>5</sub> rates gave significantly taller plants than the control for all varieties. Plant height increased as P<sub>2</sub>O<sub>5</sub> applied rate increased from zero (control) to the highest level for all varieties. The differences in height can only be attributed to varietal differences. Moreover, Erdemci *et al.* (2016) reported that difference in plant height could be due to variation in genetic make-up or the hormonal balance and cell division rate that result in changes in the plant height of the different varieties.

#### Number of seeds per pod

Number of seed per pod was significantly (P < 0.05) affected by the interaction effects of different rate of Phosphorus applications and chickpea varieties. Significantly lower (1.12) seed number was recorded for Natoli variety (Table 6). Teketay with the application of 46 kg P<sub>2</sub>O<sub>5</sub> ha<sup>-1</sup> gave the highest average seed number (1.62). Overall all varieties perform better with phosphorus application on this parameter. This finding is in line with that of Erdemci *et al.* (2016) who reported that number of

seeds plant<sup>-1</sup> of chickpea was significantly affected by the interaction effects of varieties and phosphorus fertilizer levels.

#### Number of pods per plant and thousand seed weight

The number of pods per plant and thousand seed weight were significantly (P < 0.05) affected by the main effect of varieties of chickpea and phosphorus rates. No significant interaction effect was observed on these parameters. Moreover, significant differences were observed among the four chickpea genotypes in number of pods per plant. The local variety produced highest (122) number of pods plant<sup>-1</sup>, while the lowest (67) number of pods plant<sup>-1</sup> was recorded for Natoli variety (Table 7). Genotypic variation might have played significant role in producing the varied number of pods per plant. The main effect of phosphorus showed that Phosphorus level at 46 kg P<sub>2</sub>O<sub>5</sub> ha<sup>-1</sup> resulted in maximum (92) pods plant<sup>-1</sup> while minimum (70) pods plant<sup>-1</sup> was recorded in control treatment (Table 7). The result shows that increasing phosphorus levels simultaneously increased the number of pods plant<sup>-1</sup>. There was an increase of 30.9 % in the mean number of pods per plant when 46 kg P<sub>2</sub>O<sub>5</sub> ha<sup>-1</sup> was applied compared to zero application (control). This might be due to improved availability of plant nutrients which stimulated the plants to produce more pods per plant as phosphorus encourages flowering and fruiting. This finding is in line with Kumar *et al.* (2009) that reported application of phosphorus at 50 kg P<sub>2</sub>O<sub>5</sub> ha<sup>-1</sup> significantly increased number of pods per plants in chickpea over control. Similarly it agrees with Meseret and Amid (2014) who reported that application of phosphorus fertilizer had significantly increased number of pods per plant in common bean. Thousand seeds weight also showed same trend as with number of pods per plant. Significantly (P < 0.05) higher (302g) hundred seed weight was recorded for Dalota variety and lowest (118 g) for the local variety, though there was non-significant difference between Teketay and Natoli varieties (Table 7). The main effect of phosphorus application shows that 1000-seed weight increases with increase in levels up to 46 kg P<sub>2</sub>O<sub>5</sub> ha<sup>-1</sup> which recorded the maximum weight (248g) that was at par with the application of 69 kg P<sub>2</sub>O<sub>5</sub> ha<sup>-1</sup>(Table 7). Increase in 1000-seed weight might be due to favorable climatic condition during grain filling stage as well as the formation of starch and albumin. This agrees with the findings of Amare *et al.* (2014) and Ripudaman *et al.*

(2014) who reported that increasing phosphorus rates increases 1000 seed weight.

#### Seed yield

The analysis of variance indicated a highly significant ( $P < 0.01$ ) interaction effects of phosphorus rates and varieties on seed yield of chickpea (Table 8). Significantly higher seed yield ( $2945 \text{ kg ha}^{-1}$ ) was obtained for Teketay with application of  $46 \text{ kg P}_2\text{O}_5 \text{ ha}^{-1}$ , while lower seed yield ( $1418 \text{ kg ha}^{-1}$ ) was recorded for local variety without P application. Seed yield increased as rate of  $\text{P}_2\text{O}_5$  applied increased from zero (control) to  $46 \text{ kg P}_2\text{O}_5 \text{ ha}^{-1}$ . Mean seed yield ranged from  $1728 \text{ kg ha}^{-1}$  for the control treatment to  $2509 \text{ kg ha}^{-1}$  for  $46 \text{ kg P}_2\text{O}_5 \text{ ha}^{-1}$ . Abdur *et al.* (2013) reported a significant interaction effect of chickpea varieties and phosphorus fertilizer levels on number of seed plant<sup>-1</sup>, grain yield, biological yield, seed protein content as well as net income in chickpea. This result is further supported by Erdemci *et al.* (2016) who reported that grain yield of chickpea was significantly affected by the interaction effects of varieties and phosphorus fertilizer levels.

#### Biological yield

The analysis of variance result showed a highly significant ( $P < 0.01$ ) interaction effect of variety and phosphorus rate on dry biomass yield of chickpea (Table 9). Significantly higher biological yield was obtained from Teketay ( $7991 \text{ kg/ha}$ ) and Natoli ( $7767 \text{ kg/ha}$ ) with application of  $46 \text{ kg P}_2\text{O}_5 \text{ ha}^{-1}$ , while the lowest ( $3787 \text{ kg ha}^{-1}$ ) was recorded with the local variety at zero application (Table 9). The findings of Abdur *et al.* (2013) and Erdemci *et al.* (2016) had also reported significant interaction effects of chickpea varieties with phosphorus fertilizer application rates on biological yield of chickpea.

#### Harvest index

Harvest index is the measure of physiological efficiency of a crop plant to convert photosynthates into economically important parts of the plant, that is ratio of grain to above ground dry biomass are important indicators in seed yield (Rahman *et al.*, 2013). The result showed that harvest index of chickpea was significantly ( $P < 0.05$ ) affected by the interaction of chickpea varieties and phosphorus fertilizer rates. The application  $46 \text{ kg P}_2\text{O}_5 \text{ ha}^{-1}$  in combination with local variety gave significantly

higher (43.4%) harvesting index than the rest treatments (Table 10), while Dalota with no P application recorded the lowest harvest index. The performance of the local variety over the improved varieties in terms of harvest index might partly be attributed to its adaptation to the environment. Hussain *et al.* (2002) reported that chickpea cultivars differed significantly from one another regarding to harvest index. Likewise, Chiezey *et al.* (1992) reported that lower harvest index at low level of phosphorus application might be due to poor development of plants at different growth stages.

#### Economic feasibility of chickpea production with phosphorus application

The highest net benefit of  $55,703 \text{ EB ha}^{-1}$  (Ethiopian Birr) and a 1547 % marginal rate of return was obtained with the application of  $46 \text{ kg P}_2\text{O}_5 \text{ ha}^{-1}$  followed by  $48,126 \text{ EB ha}^{-1}$  and 773 % marginal rate of return with application of  $23 \text{ kg P}_2\text{O}_5 \text{ ha}^{-1}$  (Table 11). The value to cost ratio ranged from 4 EB to 13EB per unit of investment for application of recommended  $46 \text{ kg P}_2\text{O}_5 \text{ ha}^{-1}$  fertilizer rate and non-fertilized. Therefore, the use of Teketay variety combined with  $46 \text{ kg P}_2\text{O}_5 \text{ ha}^{-1}$  fertilizer application was economically feasible for chickpea production compared to the other treatments.

#### CONCLUSION AND RECOMMENDATION

Based on the study results, it is concluded that the application of phosphorus significantly influenced the performance of the chickpea varieties. Days to 50% flowering, days to 90 % maturity, number of pod per plant, and thousand seed weight were affected by the main effects of varieties and phosphorus. Moreover, plant height, number of seeds per pod, nodule dry weight, grain yield, biomass yield and harvest index were all affected by the interaction effect of both varieties and phosphorus rate. Teketay variety was found to have performed better among the varieties with application of  $46 \text{ kg P}_2\text{O}_5 \text{ ha}^{-1}$  and a net benefit of  $55,703 \text{ EB ha}^{-1}$ . Hence, Teketay variety with  $46 \text{ kg P}_2\text{O}_5 \text{ ha}^{-1}$  was suggested for economic chickpea production and productivity in the study district.

#### REFERENCES

Abdur R., M., Isheque, K. H., Muhammad, S. and Muhammad A. (2013). Growth and yield response of



- three chickpea cultivars to varying NPK levels. *Asian Journal of Agri. Biol.* 1(3):95-99.
- Addisu A. (2013). Response of Chickpea (*Cicer Arietinum* L.) varieties to rates of nitrogen and phosphorus fertilizer at Debre Zeit, Central Ethiopia. M.Sc. Thesis. Haramaya University.
- Amare, G., Assaye, D. and Tuma, A. (2014). The response of haricot bean varieties to different rates of phosphorus at Arba Minch, Southern Ethiopia. *ARPJN Journal of Agric. Biol. Sci.* 9: 344-350.
- Anderson, J. M. and Ingram, J. S. I. (1993). Tropical soil biology and fertility. A handbook of methods. 2<sup>nd</sup> Edition pp. 93-95. CAB International U.K
- Brady, N. C. and Weil, R. R. (2002). The Nature and Properties of Soils (13<sup>th</sup> ed). Pearson Education Ltd., USA. 156-198 pp.
- Bremner, J. M. and Mulvaney, C. S. (1982). Nitrogen-total, in methods of soil analysis. Page, A. L. (Ed). Methods of soil analysis. Agronomy Monography 9. American Society of Agronomy. Madison, WI. 595-624 pp.
- Chiezey, U. F., Yayock, J. and Shebayan, A. Y. (1992). Response of soybean to N and P fertilizer levels. *Journal of Tropical Science*.32: 361-368.
- Central Statistical Agency (CSA). 2015. The Federal Democratic Republic of Ethiopia, Agricultural Sample Survey. Report on Area and Production of Major Crop. Volume 1, Addis Ababa, 18 pp.
- Dotaniya, M. L., Datta, S.C., Biswas, D.R., Meena, H.M. and Kumar, K. (2014a). Production of oxalic acid as influenced by the application of organic residues and its effect on phosphorus uptake by wheat (*Triticum aestivum* L.) in an inceptisol of North India. *Nat. Acad. Sci. Lett.* 37(5):401-405.
- Dotaniya, M.L., Datta, S.C., Biswas, D. R. and Kumar, K. (2014b). Effect of organic sources on phosphorus fractions and available phosphorus in typic Haplustept. *Indian Journal of Soc. Soi Sci.* 62(1): 80-83.
- Ejersa Lafo district production annual report (EJDA). (2015). Annual Report. PP. 16
- Erdemci, I., Aktas, H. and Nadeem, M.A. (2016). Effect of fertilization and seed size on nodulation, yield and yield components of chickpea (*Cicer arietinum* L). *Applied Ecology and Environmental Research.* 15(1): 563-571.
- Food and Agricultural Organization (FAO). (2008). Statistical databases and data-sets of the Food and Agriculture Organization of the United Nations. <http://faostat.fao.org/default.aspx>, Accessed on September, 2016.
- Food and Agriculture Organization Statistics (FAOSTAT). (2014). Food and Agriculture Organization Statistics Data Base, Agricultural production indices, Roma, Italy. <http://faostat.fao.org/default.aspx>, Accessed on September, 2016.
- Gomez A and Gomez, A. (1984). Statistical Procedure for Agricultural Research. 2<sup>nd</sup> Edition. John Wiley and sons. Inc.
- Guriqbal, S., Hari Ram., Sekhon, H.S., Navneet, Aggarwal. and Veena, Khanna. (2011). Effect of nutrient management on nodulation, growth and yield of Lentil (*Lens culinaris* Medik.) genotypes. Department of Plant Breeding and Genetics, Punjab Agricultural University, Ludhiana 141004, Punjab, India.
- Hussain, M., Shah, S. H. and Nazir, M. S. (2002). Differential genotypic response to phosphorus application in lentil (*Lens culinaris* M.). *Pakistan Journal of Agricultural Sciences.* 39: 193-196.
- International Crops Research Institute for the Semi-Arid Tropics (ICRISAT). (2010). Chickpea Seed Production Manual, Andhra Pradesh, India.
- Kumar, V., Dwivedi, V. N and Tiwari, D. D. (2009). Effect of Phosphorus and Iron on yield and mineral nutrition in chickpea. *Ann. Plant Soil. Res.* 11:16-18.
- Landon, J. R. 1991. Booker Tropical Soil Manual: A Handbook for Soil Survey and Agricultural Land Evaluation in the Tropics and Subtropics. Longman Scientific and Technical, Essex, New York, 474 pp.
- Meseret T. and Amin M. (2014). Effect of different phosphorus fertilizer rates on growth, dry matter, yield and yield components of common bean (*Phaseolus vulgaris* L). *World Journal of Agricultural Research.* 2(3): 88-92.
- Ministry of Agriculture of Eritrea (MoA). (2011). Annual Report, Asmara, Eritrea.



Olsen, S.R., Cole, F.S. and Dean, L.A. (1954). Estimation of Available Phosphorus in Soils by Extraction with Sodium Bicarbonate. USDA Circ. No. 939, Washington DC.

Rahman, M.H., Wajid, S.A., Afza, M., Ahmad, A., Awais, M. Irfan and Ahmad, A.U.H. 2013. Performance of promising lentil (*Lens culinaris medik.*) cultivars at different nitrogen rates under irrigated conditions of faisalabad, Pakistan

Ripudaman, S., Dharmendra, S., Hemant, K., Shweta, A. K., Yadav, B.K. and Sinjay, K. (2014). Performance of chickpea (*Cicer arietum L.*) under different levels of phosphorus and sulphure application. *Journal of plant archives*. 14(2):1115-1117.

Sarker, D.K.R. (2005). Study on the growth, yield and yield attributes of advanced mutants of lentil. Master's Thesis. Department Crop Botany, BAU, Mymensingh.

Statistical Analysis System (SAS). (2008) SAS institute version 9.20 Cary, NC, USA.

Tang, C., Hinsiger, P.J. Drevonn, J. and Jailard, T. (2001). Phosphorus deficiency and early nodule formation for enhance proton release in roots of *Medicago truncatula L.* *Ann. Bot.*, 88:131-138.

Tessema, T. and Alemayehu, B. (2015). Effect of phosphorus application and varieties on grain yield and yield component of common bean (*Phaseolus vulgaris L.*). *American Journal of plant nutrition and fertilization technology*. 5:79-84.

Upadhyaya, H.D., Thudi, M., Dronavalli, N., Gujaria, N., Singh, S., Sharma, S. and Varshney, R. K. (2011). Genomic Tools and Germplasm Diversity for Chickpea Improvement. *Plant Genetic Resource: Characterization and Utilization*. 9 (1): 45-58.

Walkely, A. and Black, I.A. (1934). The Degitiareff Method for Determining Soil Organic Matter and a Proposed Modification of the Chromic Acid Titration Method. *Soil Sciences*, 34: 29-38.

Yadeta, A. and Geletu, B. (2002). Evaluation of Ethiopian chickpea landraces for tolerance to drought. *Genetic Resources and Crop Evolution*. 49:557-564.

Table 1. Soil physical and chemical analysis result of the experimental site before planting in 2016

Analysis result	Depth (cm)	p <sup>H</sup> 1:2.5 (H <sub>2</sub> O)	EC ds/m	Total N %	AVP ppm	K Cmol(+)/kg	OC %	CEC Cmol(+)/kg
Before sowing	0-30	7.57	0.53	0.08	3.3	1.08	0.88	57.38

OC= organic Carbon; TN= Total Nitrogen; AVP=Total Available Phosphorus; CEC= Cation Exchange Capacity; EC=Exchangeable Cation; K= Potassium

Table 2. Main effect of varieties and phosphorus level on the phenology of chickpea in 2016

Treatment	Days to 50% flowering	Days to 90 % Physiological maturity
Varieties		
Dalota	51.5 <sup>b</sup>	117.6 <sup>c</sup>
Taketay	51.6 <sup>b</sup>	118.3 <sup>b</sup>
Natoli	56.4 <sup>a</sup>	120.4 <sup>a</sup>
Local	49.9 <sup>c</sup>	115.3 <sup>d</sup>
LSD (5%)	0.45	0.57
Phosphorus level (P <sub>2</sub> O <sub>5</sub> Kg ha <sup>-1</sup> )		
0	53.8 <sup>a</sup>	120.4a
23	52.4 <sup>b</sup>	117.4b
46	51.6 <sup>c</sup>	116.9b
69	51.6 <sup>c</sup>	116.9b
LSD (5%)	0.45	0.57
CV (%)	1.02	2.58

Means within the same column followed by the same letter are not significantly different at 5 % probability level.

Table 3. Main effects of varieties and phosphorus rates on growth, nodule and root length of chickpea

Treatment	Primary branches per plant	Secondary branches per plant	Root Length (cm)	Nodule per plant
Varieties				
Dalota	4.91b	12.41c	13.18b	48.55b
Taketay	5.33a	12.78b	13.94ab	50.75b
Natoli	4.95b	11.46d	14.45a	62.48a
Local	5.04b	14.57a	13.13b	32.08c
LSD (0.05)	0.145	0.27	0.97	2.51
Phosphorus level (P <sub>2</sub> O <sub>5</sub> Kg ha <sup>-1</sup> )				
0	4.34c	11.63d	12.71c	44.15c
23	5.12b	12.4c	13.38bc	48.3b
46	5.56a	14.38a	14.44a	52.38a
69	5.21b	12.82b	14.16ab	49.04b
LSD (0.05)	0.145	0.27	0.97	2.51
CV (%)	3.43	2.50	8.52	6.22

Means within the same column followed by the same letter are not significantly different at 5 % probability level.

Table 4. Interaction effect of phosphorus rates and varieties on nodule dry weight (g) of chickpea

Phosphorus rates (kg P <sub>2</sub> O <sub>5</sub> ha <sup>-1</sup> )	Varieties (V)				
	Dalota	Taketay	Natoli	Local	Mean
0	2.63 <sup>i</sup>	3.13 <sup>h</sup>	4.83 <sup>e</sup>	2.13 <sup>j</sup>	3.18
23	3.86 <sup>g</sup>	4.43 <sup>f</sup>	6.1 <sup>c</sup>	2.96 <sup>hi</sup>	4.34
46	4.56 <sup>ef</sup>	5.8 <sup>cd</sup>	7.26 <sup>a</sup>	3.73 <sup>g</sup>	5.34
69	4.36 <sup>f</sup>	5.53 <sup>d</sup>	6.73 <sup>b</sup>	3.23 <sup>h</sup>	4.96
Mean	3.85	4.72	6.23	3.01	
LSD (5%) PR*V=0.39				CV (%) = 5.37	

Means within the same column and row followed by the same letter are not significantly different at 5 % probability level.

Table 5. Interaction effect of phosphorus rates and varieties on the plant height of chickpea

Phosphorus rates (kg P <sub>2</sub> O <sub>5</sub> ha <sup>-1</sup> )	Varieties(V)				
	Dalota	Taketay	Natoli	Local	Mean
0	43.4g	45.81f	41.28h	48.18de	43.5
23	46.04f	48.2de	43.81g	49.33dc	46.85



46	50.33bc	52.1a	47.71e	51.53ab	50.42
69	48.12de	50.3bc	45.23f	50.06c	48.43
Mean	46.97	49.1	44.51	50.31	

LSD (5%) PR\*V=1.38;

CV (%) =1.74

Means within the same column and row followed by the same letter are not significantly different at 5 % probability level.

*Table 6. Interaction effect of phosphorus rates and varieties on number of seed per pod of chickpea*

Phosphorus rates(PR) (kg P <sub>2</sub> O <sub>5</sub> ha <sup>-1</sup> )	Varieties(V)				
	Dalota	Taketay	Natoli	Local	Mean
0	1.16kj	1.28gh	1.12k	1.24ih	1.2
23	1.28gh	1.46c	1.21ij	1.36ef	1.33
46	1.38ed	1.62a	1.28gh	1.47c	1.44
69	1.32gf	1.54b	1.23i	1.41d	1.38
Mean	1.29	1.48	1.21	1.37	

LSD (5%) PR\*V=0.048; CV (%)=2.15

Means within the same column and row followed by the same letter are not significantly different at 5 % probability level

*Table 7. Main effect of Varieties and Phosphorus rates on yield attributes of chickpea*

Treatment	Number of pods per plant	Thousand seed weight (gm)
<b>Varieties</b>		
Dalota	69c	302a
Taketay	75b	277b
Natoli	67d	274b
Local	122a	118c
LSD (0.05 %)	1.36	0.81
<b>Phosphorus level (Kg/ha)</b>		
0	70d	235b
23	84c	242ab
46	92a	248a
69	87b	245a
LSD (0.05 %)	1.36	0.81
CV (%)	1.95	4.01

Means within the same column followed by the same letter are not significantly different at 5 % probability level.

Table 8. Interaction effect of phosphorus rates and varieties on grain yield of chickpea

Phosphorus rates(PR) (kg P <sub>2</sub> O <sub>5</sub> ha <sup>-1</sup> )	Varieties (V)				
	Dalota	Teketay	Natoli	Local	Mean
0	1618 <sup>h</sup>	1929. <sup>f</sup>	1949 <sup>f</sup>	1418. <sup>i</sup>	1728.3
23	2301 <sup>e</sup>	2530 <sup>bcd</sup>	2384 <sup>de</sup>	1560 <sup>hi</sup>	2193.8
46	2612 <sup>b</sup>	2945 <sup>a</sup>	2671 <sup>b</sup>	1809 <sup>fg</sup>	2509.3
69	2414 <sup>cde</sup>	2663 <sup>b</sup>	2556 <sup>bc</sup>	1686 <sup>gh</sup>	2329.8
Mean	2236.2	2516.7	2390	1618	
LSD (5%) PR*V= 154.8;				CV (%)= 4.43	

Means within the same column and row followed by the same letter are not significantly different at 5 % probability level

Table 9. Interaction effect of phosphorus rates and varieties on biological yield of chickpea

Phosphorus rates (kg P <sub>2</sub> O <sub>5</sub> ha <sup>-1</sup> )	Varieties				
	Dalota	Taketay	Natoli	Local	Mean
0	6240 <sup>f</sup>	6373 <sup>f</sup>	6868 <sup>e</sup>	3787 <sup>h</sup>	5817
23	6866 <sup>e</sup>	7296 <sup>d</sup>	7148 <sup>de</sup>	3783 <sup>h</sup>	6273
46	7711 <sup>abc</sup>	7991 <sup>a</sup>	7767 <sup>ab</sup>	4235 <sup>g</sup>	6929
69	7347 <sup>cd</sup>	7483 <sup>bcd</sup>	7444 <sup>bcd</sup>	4348 <sup>g</sup>	6656
Mean	7041	7286	7307	4838	
LSD (5%) PR*V= 404.4;				CV (%)= 3.77	

Means within the same column and row followed by the same letter are not significantly different at 5 % probability level

Table 10. Interaction effect of phosphorus rates and varieties on harvest index of chickpea

Phosphorus rates (kg P <sub>2</sub> O <sub>5</sub> ha <sup>-1</sup> )	Varieties
---	-----------

	Dalota	Teketay	Natoli	Local	Mean
0	25.9 <sup>h</sup>	30.5 <sup>fg</sup>	28.4 <sup>hg</sup>	37.4 <sup>bcd</sup>	30.6
23	33.5 <sup>def</sup>	34.7 <sup>cdef</sup>	33.4 <sup>def</sup>	41.1 <sup>ab</sup>	35.7
46	33.9 <sup>def</sup>	36.9 <sup>bcde</sup>	34.4 <sup>cdef</sup>	43.4 <sup>a</sup>	37.2
69	32.9 <sup>efg</sup>	35.6 <sup>cde</sup>	34.3 <sup>cdef</sup>	38.8 <sup>bc</sup>	35.4
Mean	31.5	34.4	32.6	40.2	
LSD (5%) PR*V=4.5				CV (%) = 7.76	

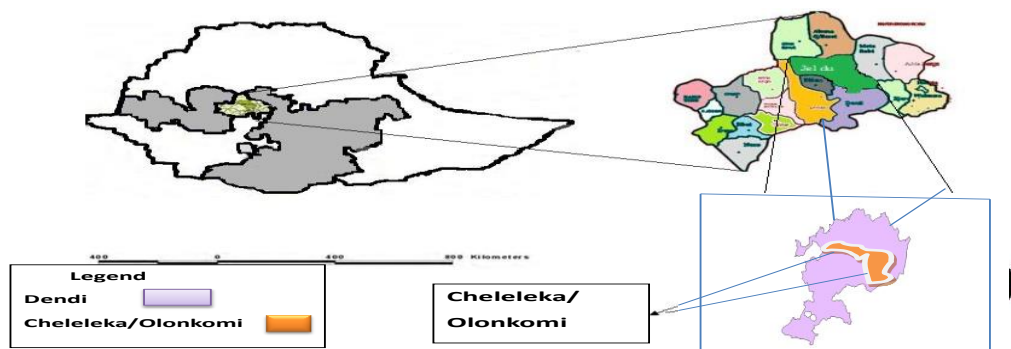
Means within the same column and row followed by the same letter are not significantly different at 5 % probability level

Table 11. Effect of phosphorus fertilizer application to economic feasibility of chickpea production.



Treatment(Variety *P <sup>2</sup> O <sup>5</sup> (kg ha <sup>-1</sup> ))	Seed		Net			Value	Marginal Rate return (%)
	yield kgha <sup>-1</sup>	Adjusted yield	GNB EB ha <sup>-1</sup>	TVC EB	benefit EB ha <sup>-1</sup>	cost ratio	
Natoli x control	1949	1754	40342	2875	37467	13	
Dalota x Control	1618	1456	33488	2990	30498 <sup>D</sup>	10.2	
Local X Control	1418	1276	25520	3000	22520 <sup>D</sup>	7.5	
Taketay X Control	1929	1736	39928	3220	36708 <sup>D</sup>	11.4	
Natoli X 23	2384	2146	49358	3900	45458	11.7	780
Dalota X 23	2301	2071	47633	4015	43618 <sup>D</sup>	10.9	
Local X 23	1560	1404	28080	4025	24055 <sup>D</sup>	6	
Tekatey X 23	2530	2277	52371	4245	48126	11.3	773
Natoli X 46	2671	2404	55292	4925	50367	10.2	330
Dalota X 46	2612	2351	54073	5040	49033 <sup>D</sup>	9.7	
Local X 46	1809	1628	32560	5050	27510 <sup>D</sup>	5.4	
Tekatey 46	2945	2651	60973	5270	55703	10.6	1547
Natoli X 69	2556	2300	52900	5950	46950 <sup>D</sup>	7.9	
Dalota X 69	2414	2173	49979	6065	43914 <sup>D</sup>	7.2	
Local X 69	1686	1517	30340	6075	24265 <sup>D</sup>	4	
Tekatey X 69	2663	2397	55131	6295	48836 <sup>D</sup>	7.8	

Where, SY=Seed Yield, GNB=Gross net benefit, TVC= Total variable cost, NB=Net benefit, MRR=Marginal Rate return, 1 kg chickpea (V) =23 EB, 1kg chickpea (Local) =20 EB and 1 kg TSP = 20.5EB.



Map of study area

Figure 1: Map of the study area

## TREND ANALYSIS AND THE DETERMINANTS OF RICE CONSUMPTION IN NIGERIA (1970 – 2016)

Elega\*, J. O., L. Tanko, M.A. Ojo

Department of Agricultural Economics & Farm Management, Federal University of Technology, Minna, Niger State, Nigeria

\*Corresponding Author's E-mail: [juliuselega@gmail.com](mailto:juliuselega@gmail.com), GSM: [07032577066](tel:07032577066)

### ABSTRACT

*This study analyzed the trend and determinants of rice consumption in Nigeria from 1970 – 2016 with the aim of providing empirical results of the trend and determinants of rice consumption in the country. Time series data were collected and tested for stationarity using ADF test and analyzed using trend and regression analyses and the error correction model. The ADF test showed that only per capita income was stationary at level, I (0), other variables were stationary at first difference, I (1) while population was stationary at second difference, I (2). The trend analysis showed that rice consumption was generally on the increase over the period of study. The coefficients of price of rice was statistically significant at 5% probability level and was found to be negatively related to rice consumption while population, rice production and rice importation were positively related to rice consumption. Population and rice importation were statistically significant at 1% probability level while rice production was significant at 5%. The ECM result shows that the coefficient (-0.8880) was negative and statistically significant at 1% probability level ( $P < 0.01$ ) which is an indication that there is a long run relationship between the variables used in the model while the short run coefficient (0.2358), shows a low speed of adjustment of the variables towards equilibrium; which implies 23.58% speed of adjustment of rice consumption towards equilibrium. The study concludes that, there was a general increasing trend in rice consumption over the period of study and that the major determinants of rice consumption were exchange rate, rice importation, price of rice as well as rice production. Based on the research findings, this study therefore recommended that the on-going anchor borrower's programme should be sustained and improved upon in order to increase rice production in the country. This will reduce the price of the product as well as the level of importation and thereby achieving the rice self sufficiency goal of the nation.*

**KEYWORDS:** Consumption, Rice, Stationarity, Trend, Unit root test.

### INTRODUCTION

Food is a basic necessity for life and all people need it for survival. Agriculture is the activity most essential for human survival as it produces the necessary food for the world's population under both rain fed and irrigated conditions (Appelgren and Klohn, 2001). The agricultural sector of Nigeria provides food for the growing population and income for millions of smallholders. Agriculture feeds people, produces basic commodities for society and provides gainful employment for the majority (Ojemade, 2007). It provides employment for about 65 percent of the labour force for industrial development and also raw materials for industries (Muhammed *et al.*, 2013).

Rice is the most consumed staple food by Nigeria's over 174 million people across States and geopolitical zones (Bamidele *et al.*, 2010). Nigeria has a rich history of rice production and consumption, as indigenous rice species (local rice) have been grown in Nigeria for years (WARDA, 2003). Rice has overtime developed into a major staple crop in the Nigerian diet,

with a demand profile cutting across all regions. A variety of other factors have also contributed to this increased demand including rapid urbanization, acceleration in the population growth rate, increase in per capita income, and changes in family occupational structures. (Akpokodje *et al.*, 2001; Akande, 2002; United Nations Environmental Programme (UNEP), 2005).

However, inadequate planning of Nigeria's agricultural sector to cope with the growing population has led to wide spread food shortage in the country (Akande, 2002). In spite of the leading position of Nigeria in the rice production, the country depends greatly on importation of rice to meet its growing demand. This is because agriculture has not really played the role of supplying adequate raw materials to the industrial sector. The impact of this act on development has been low welfare capacity, low employment, high inequality and hence high multidimensional poverty. Rising consumer preference for rice has increased demand at a faster rate. As demand for rice has risen in Nigeria to about 6 million metric tons with the level of production of

about 2.7 million metric tons and importation of about 3 million metric tons, it is clear that production has failed to keep pace while the gap has been bridge by growing imports (Wudl *et al.*, 2015). It was against this backdrop that this study sought to analyze the trend and determinants of rice consumption in Nigeria from 1970 – 2016 and the specific objectives were to: (i) analyze the trend in rice consumption in Nigeria, (ii) analyze the determinants of rice consumption in Nigeria and (iii) estimate the long run and short run effects of economic variables on rice consumption in Nigeria from 1970 – 2016.

## METHODOLOGY

### The Study Area

The study was conducted in Nigeria. Nigeria is one of the Sub-Saharan African (SSA) countries in the Western part of Africa which is located between Latitude 4°14' North of the equator and Longitude 2° 15' East of the Greenwich meridian line, with a land area of about 923769km<sup>2</sup>; a North South length of about 1,450km and a West – east breadth of about 800km. It is comprised of 36 States and the Federal Capital Territory, located in Abuja. It is the most populous country in Africa accounting for approximately one – sixth of Africa's people with an estimated population of about 182.2 million people in 2015 which was projected to be about 196.2 million people in 2018 at 2.5% growth rate (National Bureau of Statistics (NBS), 2015). The common cash crops and food products in Nigeria are yam, rice, cassava, millet, sweet potato, groundnuts, palm oil, sheep, cattle, pig, shea butter, cotton, gum, rubber and cocoa.

### Methods of Data Collection

The longitudinal survey design was adopted for this study. Time series data spanning from 1970 to 2016 was collected on population, quantities of domestic and imported rice, price of domestic rice, per capita rice consumption and per capita income. The data was accessed in the month of April, 2018.

### Data Analytical Technique

Both descriptive and inferential statistics were used to analyze the data in line with the stated objectives. Objectives i, ii and iii were analyzed using trend analysis, regression analysis and the error correction model respectively.

### Model Specification

#### Augmented Dickey – Fuller (ADF) Unit Root Test

$$\Delta Y_t = \alpha_0 + \alpha_2 t + \beta_1 Y_{t-1} + \sum_{i=1}^p \beta_2 \Delta Y_{t-1} + e_t$$

(1)

Where:  $Y_t$  = current value of consumption of rice,  $t$  = time trend variable,  $\Delta$  = change operator,  $P$  = optimal lag length,  $\alpha_0$  = constant,  $\alpha_2$ ,  $\beta_1$ ,  $\beta_2$  = coefficient to be estimated and  $e$  = error term.

**Decision Rule:** Stationarity is confirmed if the ADF statistic is greater than the critical value at a specified level of significance, otherwise the series is non-stationary.

### Regression Analysis

To analyze the determinants of rice consumption in Nigeria, a regression model specified as a consumption function was estimated as in equation 2:

$$C = \beta_0 + \beta_1 \text{POR} + \beta_2 \text{PCI} + \beta_3 \text{EXC} + \beta_4 \text{TRI} + \beta_5 \text{TRP} + \beta_6 \text{POP} + u$$

(2)

Where:  $C$  = Quantity of rice consumed (tons),  $\text{POR}$  = Price of rice (₦/ton),  $\text{PCI}$  = Per capita income (₦),  $\text{EXC}$  = Exchange rate (₦/\$),  $\text{TRI}$  = Total quantity of rice imported (tons),  $\text{TRP}$  = Total quantity of rice produced (tons),  $\text{POP}$  = Population (number) and  $u$  = error term.

### Error Correction Model (ECM)

The Error Correction Model (ECM) is specified as:

$$\Delta \ln C = \beta_0 + \sum_{i=1}^p \beta_1 \Delta \ln \text{POP}_{t-1} + \sum_{i=1}^p \beta_2 \Delta \ln \text{PCI}_{t-1} + \sum_{i=1}^p \beta_3 \Delta \ln \text{POR}_{t-1} + \sum_{i=1}^p \beta_4 \Delta \ln \text{TRP}_{t-1} + u_t$$

(3)

Where:  $\ln$  = natural log,  $\beta_0$  = constant,  $\beta_1 - \beta_4$  = coefficients to be estimated,  $\Delta$  = change operator,  $p$  = optimal lag length,  $C$  = quantity of rice consumed (tons),  $\text{POP}$  = population (number),  $\text{PCI}$  = per capita income (₦),  $\text{POR}$  = price of rice (₦/ton),  $\text{TRP}$  = total quantity of rice produced (tons) and  $u$  = error term.

## RESULTS AND DISCUSSION

### Determination of Time Series Properties of Data Employed for Analysis

As a first step in the analysis involving the use of time series data, the stationarity of the variables is required. The properties of the time series data were tested using Augmented Dickey Fuller (ADF) test to determine the stationarity of the variables under consideration as presented in table 1. The ADF test shows that only rice per capital consumption was stationary at level with order of integration 0,  $I(0)$  while other variables were non stationary at levels but became stationary at first difference with order of integration 1,  $I(1)$ . However, population was not



stationary at first difference but only became stationary at second difference with order of integration 2, I (2). Also, rice consumption and rice per capita consumption were both significant at 5% probability level while other variables were significant at 1% probability level.

### **Trend of Rice Consumption in Nigeria (1970 – 2016)**

The result of the trend of rice consumption in Nigeria from 1970 to 2016 as presented in figure 1 shows that there was a general increase in rice consumption during this period. The increasing growth in rice consumption could be attributed basically to population growth. The annual consumption of rice rose from 1970 to 1985 with a drop from 1986 to 1990. This was followed by a steady increase from 1991 to 2014. However, rice consumption has been on the fall since 2015 and this could be attributed to the rising price of the product as a result of the ban on rice importation. This is in line with the findings of Oyinbo *et al.* (2013) who found an increasing trend in rice demand in Nigeria. Also, Tihamiyu *et al.* (2014) found a positive and increasing trend in rice consumption in Nigeria from 1960 to 2013.

### **Determinants of Rice Consumption in Nigeria**

Table 2 presents the result of the determinants of rice consumption in Nigeria from 1970 to 2016. The result shows a coefficient of determination,  $R^2$  of 0.9844; this is an indication that the explanatory variables explained about 98% of the variation in rice consumption while the remaining 2% was explained by the error term and other variables not included in the model. The F-ratio (438.31) was found to be statistically significant at 1% probability level. This shows a goodness of fit for the model and an indication that the entire model was significant; and that the explanatory variables jointly predicted the variations in rice consumption. The coefficient of the price of rice was statistically significant at 5% probability level and was found to be negatively related to rice consumption; this is an inverse relationship which implies that a unit increase in the price of rice will decrease rice consumption by 1778.645 units and vice versa. Also, population, rice production and rice importation were positively related to rice consumption, but while population and rice importation were significant at 1% probability level, rice production was significant at 5%. Therefore, the major determinants of rice consumption in Nigeria within the period of study were population growth, price of rice, rice production and importation. This is in line with the findings of Tihamiyu *et al.* (2014) who studied trend analysis of rice consumption in Nigeria and concluded that the

increase in milled rice consumption was due to population growth and rice availability.

### **Johansen Co-integration Test**

The result of Johansen co-integration test shows a trace statistic of 72.2477 which is greater than the critical value of 69.8188 at 5% level of significance ( $P < 0.05$ ); this implies that there was one co-integration equation among the variables. Therefore, based on the decision rule, the null hypothesis of no co-integration among the variables; rice consumption, population, per capita income, price of rice and rice production was rejected. This shows that there is a long run relationship among the variables.

### **Error Correction Model (ECM)**

In the long run, the results of the Error Correction Model (ECM) for rice consumption show that the ECM coefficient (-0.8880) was negative and statistically significant at 1% probability level ( $P < 0.01$ ) which is an indication that there is a long run relationship between the variables used in the model (population, per capita income, price of rice and rice production) and rice consumption during the period under study. The results also show that the coefficient of population (0.3128) and rice production (2.5311) were found to be positively related to rice consumption and statistically significant at 10% ( $P < 0.10$ ) and 1% ( $P < 0.01$ ) probability level respectively. This is a direct relationship which means that a unit increase in population and rice production will result in 0.31 and 2.35 unit increase in rice consumption respectively and vice versa. This result is in line with the findings of Onu *et al.*, (2015) who studied the empirical assessment of the trends in rice production and imports in Nigeria (1980 – 2013) and asserted that Population growth and urbanization were the principal factors driving increased rice demand in Nigeria.

In the short run, the ECM coefficient for rice consumption as presented in table 3 was 0.2358, which indicates a low speed of adjustment of the variables towards equilibrium which implies 23.58% speed of adjustment of rice consumption towards equilibrium.

### **CONCLUSION AND RECOMMENDATIONS**

The study analyzed the trend and determinants of rice consumption in Nigeria from 1970 to 2016 and concludes that there was a general increasing trend in the consumption of rice over the period of study and that the major determinants of rice consumption were population growth, per capita income, exchange rate, rice importation, price of rice and rice production. It was therefore recommended that the on-going anchor

borrower's programme should be sustained and improved upon in order to increase rice production in the country. This will reduce the price of the product

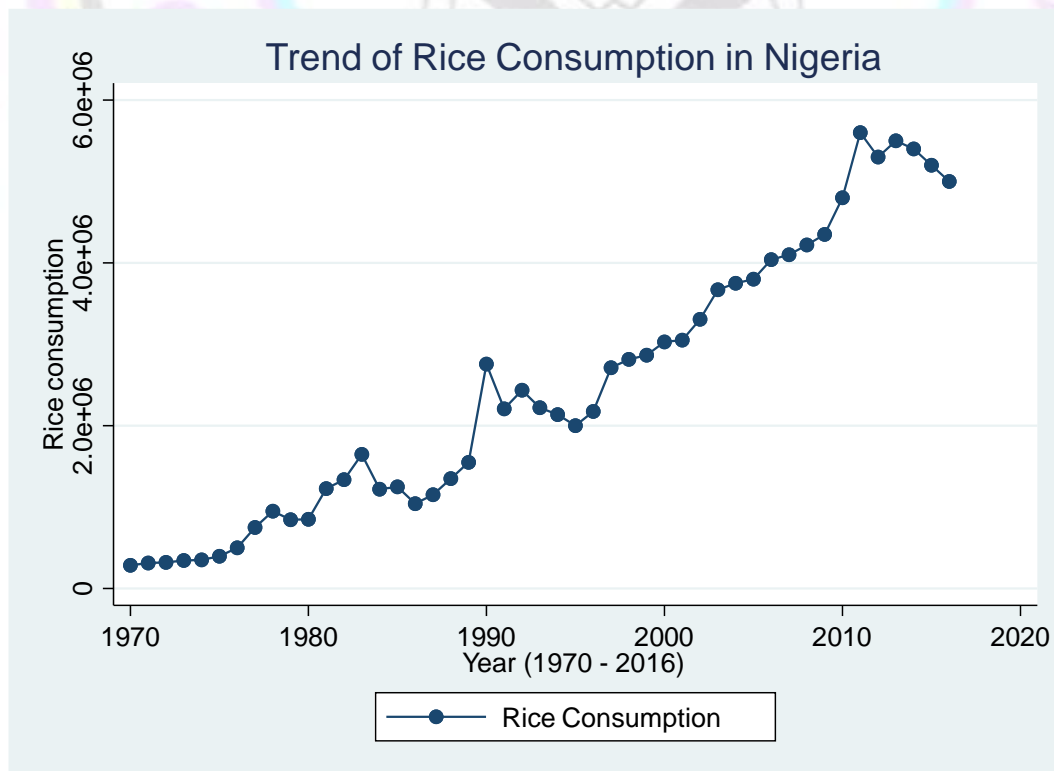
as well as the level of importation and thereby achieving the rice self sufficiency goal of the nation.

**Table 1: Augmented Dickey Fuller (ADF) Unit Root Test of Variables**

Variable	1 <sup>st</sup>		2 <sup>nd</sup>	Order of Integration	Critical Value (5%)
	Level	Difference	Difference		
Exchange rate	-0.725 (0.9715)	-4.486*** (0.0050)		I(1)	-3.524
Per capita income	-2.020 (0.5906)	-4.513*** (0.0014)		I(1)	-3.524
Per capita consumption (rice)	-3.815** (0.0158)			I(0)	-3.524
Population	7.678 (1.0000)	-2.876 (0.1704)	-12.047*** (0.0000)	I(2)	-3.524
Rice production	-2.387 (0.3866)	-5.636*** (0.0000)		I(1)	-3.524
Rice consumption	-3.089 (0.1088)	-4.197** (0.0045)		I(1)	-3.524
Rice importation	-2.058 (0.5694)	-5.228*** (0.0001)		I(1)	-3.524
Price of rice	-1.137 (0.9226)	-6.220*** (0.0000)		I(1)	-3.524

Source: Author's computation from E-views, 2018.

\*\*\* and \*\* implies significant at 1% and 5% probability levels respectively



**Figure 1: Trend of rice consumption in Nigeria (1970 – 2016)**

**Table 2: Determinants of rice consumption in Nigeria**

Variable	Coefficient	Std. Error	t – statistics
Constant	-1382554	378228.2	-3.655345***
Price of rice	-1778.645	796.3383	-2.233529**
Population	27.99814	7.075649	3.956971***
Per capita income	45.73402	62.92320	0.726823
Rice production	0.413525	0.163800	2.524571**
Exchange rate	1523.051	2405.955	0.633034
Rice importation	0.416238	0.110633	3.762344***
R – squared	0.9844		
F – statistics	419.3680***		

**Source:** Author's computation from E-views, 2018.

\*\*\*, \*\* and \* implies significant at 1%, 5% and 10% probability level respectively.

**Table 3: Estimates of the Vector Error Correction Model for Rice consumption**

Variable	Coefficient	Standard Error	t-statistics
<b>Long Run</b>			
ECM (-1)	-0.8880	0.2841	3.13***
POP (-1)	0.3128	0.1854	1.69*
PCI (-1)	-0.0029	0.0028	1.03
POR (-1)	-0.0767	0.0254	3.02***
RPRO (-1)	2.5311	0.9263	2.73***
Constant	-4.58e-06	4.49e-06	1.02
<b>Short Run</b>			
ECM (-1)	0.2358	0.1056	2.23***
POP (-1)	-11139.61	9680.488	1.15
POP (-2)	7.10e-08	3.0e-08	2.39***
PCI (-1)	89.8096	198.132	0.45
PCI (-2)	-150.1664	148.8084	1.01
POR (-1)	-106.4565	1325.417	0.08
POR (-2)	282.6698	116.0669	2.44***
RPRO (-1)	0.0533	0.2343	0.22
RPRO (-2)	447.7704	255.525	1.87*
Constant	33.1532	42.1365	0.78
R-squared	0.6615		
Adj. R-squared	0.5521		
F-statistics	181.11***		
AIC	26.8424		
HQIC	37.6127		
SC	39.9313		

**Source:** Output from data analysis, 2018.

\*\*\*, \*\* and \* implies significant at 1%, 5% and 10% probability level respectively.

**RCON** = Rice consumption; **POP** = Population; **PCI** = Per Capita Income; **POR** = Price of Rice; **RPRO** = Rice production.



## REFERENCES

- Akande, S.O. (2002). *An Overview of the Nigerian Rice Economy*. Nigeria Institute for Social and Economic Research (NISER), University of Ibadan press, Oyo state Nigeria.
- Akpokodje, G., Loncon, F. & Erenstein, O. (2001). Nigeria's rice economy: State of the art. A Paper presented at the NISER/WARDA Nigeria Rice Economy Stakeholders Workshop Ibadan, 8 – 9 November, 2001. Boake WARDA.
- Appelgren, B. & Klohn, W. (2001). From Water to Food Security: Water and Ethics. EGS General Assembly, Nice, March, 2001.
- Bamidele, F. S., Abayomi, O. O., & Esther, O. A. (2010). Economic Analysis of Rice Consumption Patterns in Nigeria. *Journal of Agricultural Science Technology*, 12, 1–11.
- Chukwuji, C.O, Inoni, O.E & P.C. Ike (2007). Determinants of Technical Efficiency in Garri Processing in Delta State, Nigeria. *Journal of Central European Agriculture*. 8(3): 327-336.
- Food and Agricultural Organization Statistics (FAOSTAT) (2015) Trend of Cassava Production in Nigeria, from 1980- 2013.
- International Fund for Agricultural Development (IFAD) (2004). The Global Cassava Development Strategy: A cassava industrial revolution in Nigeria The potential for a new industrial crop. In: Philips, T.P; Taylor, D.S; Sani, L & Akoroda M.O. (eds). International Fund for Agricultural Development.
- International Institute for Tropical Agriculture (IITA) (2001). Cassava in Malawi: from Drought to Food Security, Annual Report. 2001. Ibadan Nigeria.
- International Institute for Tropical Agriculture (IITA) (2004). Nigerian's Cassava Industry: Statistical Handbook.
- Muhammed L.A, Omotesho A.O & Oyedemi F.A (2013). An Assessment of the Economics of Cassava Production in Kwara State, Nigeria. A paper presented at the 4th International Conference of the African Association of Agricultural Economists, September 22-25, 2013, Hammamet, Tunisia
- Nigerian Institute of Social and Economic Research (NISER) (2013). Reducing Food Crop Losses through Post Harvest Management in Nigeria, NISER Unpublished Research Study, NISER, Ibadan Oyo State, Nigeria.
- Onyemauwa C.S. (2010). Analysis of Household Consumption of Cassava Products in Ohaozara, Ebonyi State, Southeast Nigeria. *Researcher's Journal*, 2(6):1-6.
- Oyinbo, O., Damisa, M.A & Rekwot, G.Z (2013). Growth trend of rice demand and supply in Nigeria: An investment opportunity for youth and women empowerment. *Russian Journal of Agriculture and Socio – Economics* 4(16):31-34.
- Sanusi, L.S (2012). Industrial Agricultural Raw Materials: Critical Issues in Processing, Marketing and Investment.
- Tiamiyu, M.S.A (2014). Trend analysis of milled rice consumption in Nigeria. *International Journal of Agricultural Policy and Research*. 2(10): 352-356
- United Nations Environmental Programme (UNEP) (2005). "Integrated assessment of the impact of trade liberalization: A Country Study on the Nigerian Rice Sector." United Nations Environmental Program (UNEP), Geneva, Switzerland.

# EXPOLATORY ANALYSIS OF CONSTRAINTS TO LIVELIHOOD DIVERSIFICATION AMONG IFAD-VCDP FARMERS IN BENUE STATE, NIGERIA

Sallawu<sup>1\*</sup>, H., Nmadu<sup>1</sup>, J. N., Coker<sup>1</sup>, A. A. A. and Mohammed<sup>1</sup>, U. S.

<sup>1</sup>Department of Agricultural Economics and Extension Technology, Federal University of Technology, Minna, Nigeria.

\*Corresponding Author's E-mail: [halima.sallawu@futminna.edu.ng](mailto:halima.sallawu@futminna.edu.ng) GSM: [08034532845](tel:08034532845)

## ABSTRACT

*This study investigated the constraints to livelihood diversification among IFAD-VCDP farmers in Benue State, Nigeria. A two-stage sampling technique was employed in the selection of respondents. A total of 240 respondents were selected for this study. Descriptive statistics and principal component analysis (PCA) were the analytical tools engaged in this study. The study revealed that mean age and household size were 7 and 46 respectively. The PCA result revealed that the most severe constraints the farmers faced in livelihood diversification hierarchically were public and institutional constraint; educational and training constraint; climate and production constraint; trade, norms and religious beliefs constraint; and time and skilled labour constraint. It was therefore recommended that there is need for both the government and non-government organizations to intensify efforts on public, institutional, educational and climate policies so as to increase livelihood opportunities in the study area.*

**KEYWORDS:** Livelihood diversification, Constraints, IFAD-VCDP, Factor analysis

## INTRODUCTION

Livelihood is an idea that has been gaining increasing currency in recent years and is now seen as fundamental to poverty and climate risk reduction approaches around the world. For most households, and especially for poor farm households assets are deployed in a series of livelihood activities: that is, the means through which a household gains an income and meets its basic needs (Mabe *et al.*, 2014). Livelihoods are dynamic and people adapt and change their livelihoods with internal and external stressors. Ultimately, successful livelihoods transform assets into income, dignity and agency, to improve living conditions, a prerequisite for poverty alleviation (Sallawu *et al.*, 2016). Livelihood diversification is defined as a process by which household members construct a diverse portfolio of activities and social support capabilities in their struggle for survival and in order to improve their standards of living (Ellis, 2000). Accordingly, in this study, livelihood diversification refers to the attempts by individuals and households to find new ways to raise incomes and reduce vulnerability to different livelihood shocks.

The Value Chain Development Programme (VCDP) is a six-year development initiative of the Federal Government of Nigeria (FGN) and International Fund for Agricultural Development (IFAD) programme that focuses on supporting cassava and rice value chains for small farmers in the six states of Anambra, Benue, Ebonyi, Niger, Ogun and Taraba. Within each state, the programme is being implemented in five (5) Local Government

Areas (LGAs) selected on the basis of objective criteria. VCDP is well anchored in Nigeria government's vision for agricultural transformation through commodity value chain approach, with emphasis on enhancing productivity and access to markets for rice and cassava smallholder farmers.

Climate change and extreme weather events present severe threats and erode essential needs, capabilities and rights more especially for the poor farm households and marginalized thereby redesigning their livelihoods (IPCC, 2014). A number of livelihoods are directly climate sensitive, such as rain fed agriculture, seasonal employment in agriculture and tourism (IPCC, 2014). That is, almost all sectors in agriculture (crop, livestock, pastoralism, fishery) depend on weather and climate whose variability have meant that rural farmers who implement their regular annual farm business plans risk total failure due to climate change effects (Ozor *et al.*, 2010). Livelihood diversification among farm households is very important due to population growth, the subsequent progressive shrinking of land holdings size and climate variability. The findings of the study are expected to indicate the policy interventions that might improve farmers livelihoods to raise incomes and help guide investment priorities in the study area. Researchers will also find the body of literature useful in their quest to extend frontiers of knowledge. The objectives of this study were to describe the socio-economic characteristics of farmers and constraints to livelihood diversification among farmers under IFAD-VCDP in Benue State.

## MATERIALS AND METHODS

The study was conducted in Benue State, Nigeria which was created from the former Benue-Plateau State in 1976. The State lies in the North Central Nigeria between Latitudes 6°25' and 8° 8' North of the Equator and Longitudes 7°47' and 10° 0' East of the Greenwich meridian, with total landmass of 34,059 square kilometers. The State shares boundaries with Nassarawa to the North, Taraba to the East, Ebonyi and Cross River to the South, Enugu to the South West, Kogi to the West. It also shares an international boundary with the Republic of Cameroon to the South East (Figure 1). Going by the population growth rate in Nigeria of 2.8% (World Bank, 2016), the 2006 population of the State (NPC, 2006) is projected to 5,552,212 as at 2017. Benue state comprises of 23 LGAs divided into three Agricultural Development Project zones.

It is inhabited predominantly by the *Tiv* and *Idoma* people. Other ethnic groups include *Igede*, *Etulo*, *Abakwa*, *Jukun*, *Hausa*, *Igbo*, *Akweya*, and *Nyifon*. The State experiences two distinct seasons, the wet season and the dry season with mean temperature of 28°C. Benue State has abundant human and material resources, most of the people in the State are farmers while inhabitants of the riverine areas engage in fishing as their primary or secondary occupations. Benue State is acclaimed the nation's food basket because of its diverse rich agricultural produce which includes yams, rice, beans, cassava, soya beans, benniseed, maize, millet, tomatoes and a lot of fruits. Poultry, goat, sheep, pigs and cattle are the major domestic animals kept (Benue State Agricultural and Rural Development Authority (BSARDA), 1998).





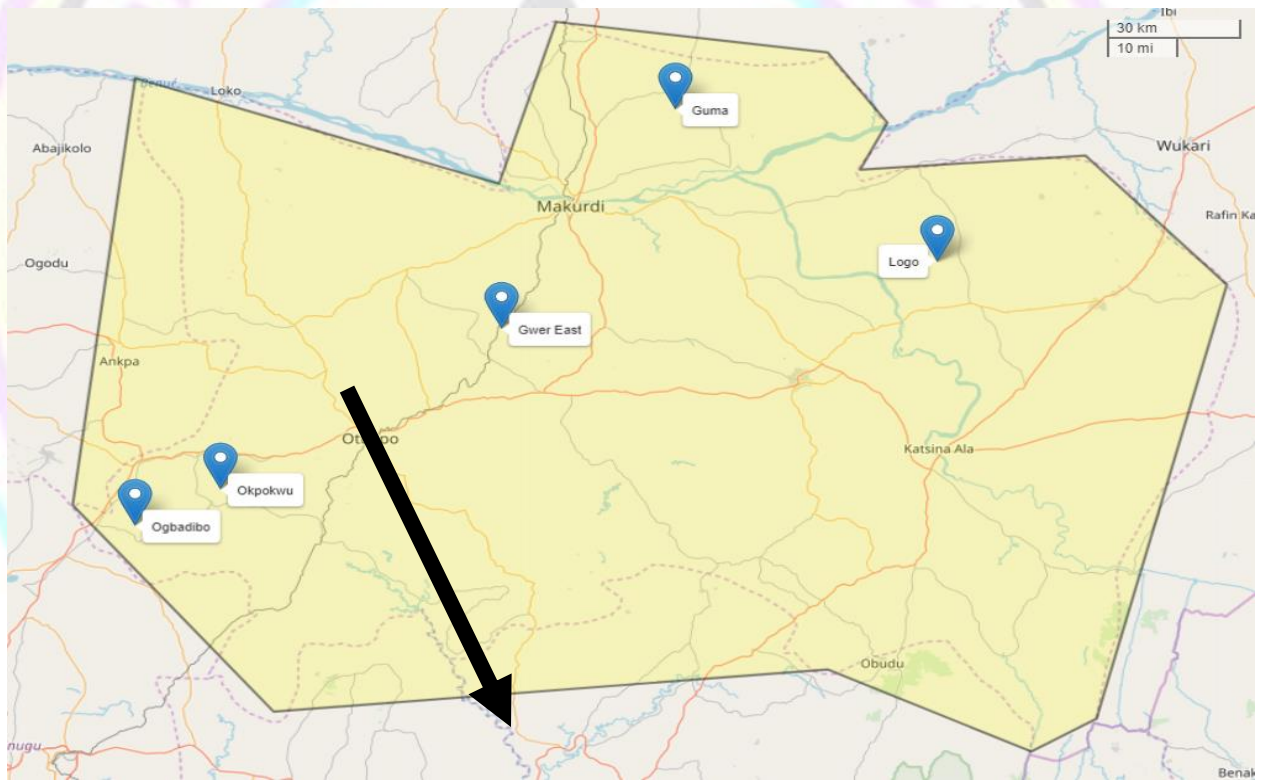
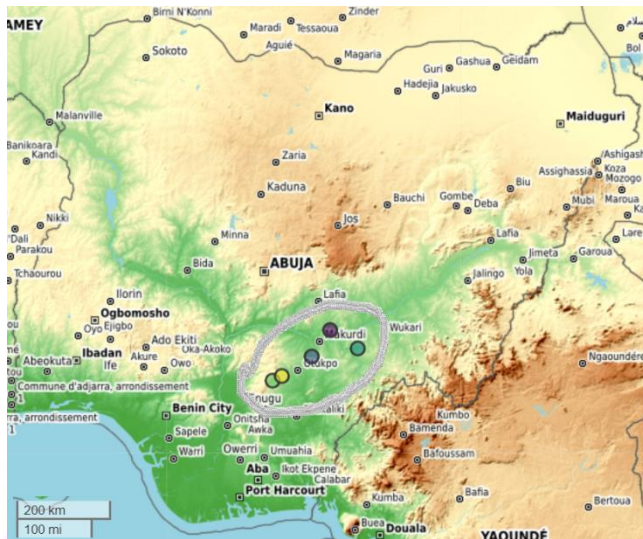


Figure 1 Map of Nigeria showing the participating Local Government Areas in IFAD-VCDP in Benue State, Nigeria<sup>1</sup>

<sup>1</sup>The maps are produced using a combination of some R packages i.e. Pebesma (2018), Cheng, Karambelkar & Xie (2018), Appelhans, Detsch, Reudenbach & Woellauer (2018), Kahle & Wickham (2013), Wickham, H. (2017)

A two-stage sampling technique was employed in the collection of primary data for this study. In the first stage, all the five (5) participating Local Government Areas (LGAs) in the State were selected. In the second stage, sampling of farm households in each community was determined proportionately using Krejcie and Morgan (1970) formula and adopted by Ardakani *et al.* (2012). The formula is presented in eqn. (1)

$$S = \frac{\chi^2 NP(1-P)}{d^2(N-1) + \chi^2 P(1-P)} \quad (1)$$

Where:

- S = The required sample size,
- $\chi^2$  = Table value of chi-square for 1 degree of freedom at the desired confidence level (1.96),
- N = Population size,
- P = Population proportion (assumed to be 0.80),
- $d^2$  = Degree of accuracy squared expressed as a proportion (0.05) and
- 1 = Constant

A total of 240 respondents were selected for this study. The data was collected using interview schedules with the aid of trained enumerators. The data were analyzed using descriptive statistics and principal factor model. Factor analysis is a data reduction technique used to reduce a large number of variables to a smaller set of underlying factors that summarize the essential information contained in the variables. The constraints were grouped using principal factor method with varimax orthogonal rotation method developed by Kaiser (1958). The factor solution should explain at least half of each original variable's variance, so the communality value for each variable should be 0.30 or higher. The criterion of eigen value or characteristic root (Eigen value) greater than 1.0 was used for defining the number of the factors that were retained (Chong *et al.*, 2013). Model acceptance was based on three criteria: each variable, in order to be included in the variable cluster of a factor, must load to it more than 0.4, each factor must have more than two variables and variables that load in more than one constraint were discarded following Akinlagbe (2010); Anselm and Taofeeq (2010); Mohammed *et al.* (2013). The model is presented in eqn. (2) as:

$$\begin{aligned} Y_1 &= a_{11}X_1 + a_{12}X_2 + \dots + a_{1n}X_n \\ Y_2 &= a_{21}X_1 + a_{22}X_2 + \dots + a_{2n}X_n \\ Y_3 &= a_{31}X_1 + a_{32}X_2 + \dots + a_{3n}X_n \end{aligned}$$

(2)

\*

\*

$$Y_n = a_{n1}X_1 + a_{n2}X_2 + \dots + a_{nm}X_n$$

Where:

$Y_1, Y_2, \dots, Y_n$  = Observed variables/ constraints to livelihood diversification;

$a_1 - a_n$  = Constraint loading or correlation coefficients;

$X_1, X_2, \dots, X_n$  = Unobserved underlying factors constraining farm households to diversify livelihood.

To judge the sampling adequacy and the factorability of the matrix as a whole, Bartlett's test of sphericity and the Kaiser-Meyer-Olkin (KMO) was used. Bartlett's test of sphericity relates to the significance of the study and therefore shows the validity and suitability of the responses collected. If the KMO is greater than 0.8 (meritorious) then factorability is assumed. High values Kaiser-Meyer-Olkin (KMO) between 0.8 and 1.0 indicate factor analysis is appropriate (Chong *et al.*, 2013).

## RESULTS AND DISCUSSION

**Socio-economic characteristics of IFAD-VCDP farmers in Benue State:** Figure 1 presents the age distribution of the farmers which revealed that the average age of the respondents was 46 years. Most of the respondents are within the age range of 30-59 years which accounted for over 80%. This implies that livelihood diversification is common among the households headed by the young who are more energetic and could afford to take the risks associated with livelihood diversification. This agrees with the findings of Awoniyi and Salman (2012) which pointed out that majority of the households that are engaged in livelihood diversification are still in their productive years. They are able to engage themselves in multiple income generating activities that can enhance the households' purchasing power and consequently their welfare status.

Finding in figure 2 below revealed that an overwhelming majority of the farmers were male representing over 70%. This is an indication that the males dominated agricultural activities. This agrees with the findings of Sallawu *et al.* (2016) who revealed that the males dominated the work force in Nigeria's agricultural communities.

Findings in figure 3 below revealed that majority of the farmers have family sizes ranging from 1-10 which accounted for over 80%. From the analysis, household size in the study area is fairly large with an average of 7 members. This is in line with the finding of Okere and Shittu (2012) who affirmed that larger households may have to depend



on more income generating activities for sustainable livelihood than smaller sized households.

Majority of the respondents were married which accounted for over 70% as depicted in Figure 4. This in line with the findings of Atagher and Okorji (2014) who revealed that majority of the farmers in Benue State were married which accounted for over 70% of the respondents.

In terms of level of education as depicted in figure 5, 25% of the farmers have completed secondary school education, 21% are still undergoing programmes in colleges of education, 13% have completed university education and 11% have completed primary education in the study area. It can be seen that the literacy level of farm households in the study area was fairly low. This is in line with the findings of Awoniyi and Salma (2012) who pointed out that low educational level among farming households undoubtedly affect their livelihood diversification patterns and that generally, there is a low level of education among the rural farming households and this has implications for their income-earning capacity as the respondents may lack the required skill to secure well paid jobs. Also, farmers may find it difficult to adopt modern improved techniques of production or operations because of their lack of education. Education enhances the technical competence and entrepreneurial spirit.

**Exploratory Factor Analysis:** The factorability of the 22 constraint variables was examined. Several well-recognized criteria for factor analysis were used. Firstly, it was observed that all the 22 variables correlated at least 0.3 with at least one other variable which shows that the variables are correlated but not highly correlated, indicating that there is relationship between the variables and also uniquely contributing to explaining the data matrix of the variables scale, suggesting reasonable factorability. Secondly, the Kaiser-Meyer-Olkin (KMO) measure of sampling adequacy was 0.836 which is meritorious based on the KMO classification. The KMO provides an overall measure of the overlap or shared variance between pairs of variables. Since the study tried to identify variables that are related but yet provide unique information to the factors, higher values indicate overlap but not to the point of hindering the analysis due to multicollinearity. The Bartlett's test of sphericity was significant ( $\chi^2(231) = 2905.957$   $P < 0.001$ ), which shows that the matrix is significantly different from zero (0), that is, the matrix is significantly different from identity matrix. This indicated that there are sufficient inter-correlations to conduct the factor analysis. Given all the above indicators, factor analysis was deemed to be suitable with all 22 variables.

Table 1 showed the varimax-rotated principal component analysis (PCA) of constraints to livelihood diversification of farmers under (IFAD-VCDP) in Benue State, Nigeria. From the result, five factors were extracted based on the responses of the farmers. The Kaiser criterion (1960) as used by Mohammed *et al.* (2013) and Chong *et al.* (2013) was used for selecting the number of underlying factors or principal components to be retained. Typically, what was considered in terms of what factors to retained are the eigen values, the uniqueness of each variable, communality and the number of individuals that are in the analysis. In this study, the number of factors was decided by leaving out components with corresponding Eigen values (a measure of explained variance) of less than one. Only variables with factor loadings of  $\pm 0.40$  and above at 10% overlapping variance were used in naming the factors. Variables that loaded in more than one constraint were also discarded. The communality which is the percentage of variance for the variable that is explained by the common factors for all the variables are above 0.30. Uniqueness could be pure measurement error or it could represent something that is measured reliably in that particular variable, but not by any of the others. If the uniqueness is high, then the variable is not well explained by the factor. The eigen values and the proportion of eigen values explained in terms of the variability of 18 variables were retained are presented in Table 1.

After the factor analysis, the first combination of variables in the first factor explained about 31% of the variance, the second factor component explained about 16% of the variance, the third factor explained about 7.8% of the variance, the fourth factor explained about 5.6% of the variance and the fifth factor explained about 4.6% of the variance in the 18 variable scale. The true factors that were retained explained 65% of the variance in the 18 constraining factor or variable components.

To make the structural factor more interpretable, the factors were rotated using varimax orthogonal rotation. This is done to maximize the distance between the factors orthogonally. These factors are: 1: Public and institutional constraint, 2: Educational and training constraint, 3: Climate and production constraint, 4: Trade, norms and religious believes constraint and 5: Time and skilled labour constraint.

**Public and institutional constraint:** The variables that load high in factor 1 are: inadequate infrastructure (0.831), inadequate access to capital (0.825), unstable price of transportation cost (0.791), government policy (0.785), inadequate credit facilities (0.771), no urban centre in proximity (0.638), inadequate input delivery system (0.637),



lack of access to market (0.581) and poor transportation system (0.529). This is in line with the findings of Ewebiyi and Meludu(2013) which revealed that there are various challenges to livelihood diversification among the rural dwellers which includes lack of infrastructural facilities, inadequate livelihood assets and, poor transportation system. Lending credence to this, Zigale (2016) pointed out that several constraints act as obstacles to livelihood diversification, and main constraints faced by the households were poor asset base, lack of financial facilities, lack of infrastructure, and lack of opportunities in non-farm activity.

**Educational and training constraint:** The variables that load high in factor 2 are: lack of skill training and ability (0.853) and limited education (0.852). This is in accordance with the findings of Hussein and Nelson (2004) which revealed that constraints to livelihood diversification are low population, no urban center in proximity, market access, government policy that extract surplus, limited availability of education and skill training. This is also in line with the findings of Zigale (2016) which pointed out that constraints to livelihood diversification are poor asset base, lack of financial facilities, lack of awareness and training facilities and lack of opportunities in non-farm activity.

**Climate and production constraint:** The variables that load high in factor 3 are: rainfall variability (0.882), declining farm size (0.770) and shortage of animal feed (0.624). This is in line with the findings of Ayele (2008) who pointed out that rainfall variability, declining farm size, lack of draught power and institutional deficiencies in credit and input delivery are the major constraints to livelihood endeavours.

**Trade, norms and religious believes constraint:** The variables that loads high in factor 4 are: restriction on trade and movement (0.796) and norms and religious believes (0.585). This is in line with the findings of Hussein and Nelson (2014) revealed that constraints to livelihood diversification are restriction on trade and movement, government policy that extract surplus, terms of trade, norms and religions.

**Time and skilled labour constraint:** The variables that loads high in factor 5 include: shortage of time (0.662) and inadequate skilled labour (0.650). This is in accordance with the findings of Hussein and Nelson (2014) who revealed that constraints to livelihood diversification are availability of infrastructure, skilled labour availability and shortage of time.

By utilizing factor rotation, it was established that there are five constructs that consists of more than one variable. Meanwhile, it is important to calculate the internal consistency reliability for

coefficient alpha for the whole scale and for each factor retained. Cronbach's alpha test was used to test the consistency between the items in the entire scale and for each factor. The Cronbach's alpha is based on the average inter-item correlation. According to Pallant (2015), a scale with a Cronbach's alpha higher than 0.7 is required in order to create a reliable construct of exploratory studies. Based on the results of the reliability consistency presented in Table 2 revealed that coefficient alpha for the overall scale was 0.877 which is very good. The internal consistency reliability for factor 1 was 0.906 which is excellent, coefficient alpha for factor 2 was 0.826 which is very good, coefficient alpha for factor 3 was 0.806 which is also very good, coefficient alpha for factor 4 was 0.756 which is good and coefficient alpha for factor 5 was 0.749 which is also good. This implies that the most severe constraint is public and institutional, followed by educational and training, followed by climate and production, then trade, norms and religious believes constraint and the least constraint is time and skilled labour. This implies that opportunities to diversity vary among households, with differences in resource endowments (land, labour, capital) and access to markets and institutions playing a central role in the extent to which diversification occurs. The livelihood diversification of the farm household portfolio of activities is determined not only by asset portfolios but also having the skills, location, capital, credit and social connections.

## CONCLUSION

In conclusion the study has validated empirical findings of many studies by revealing the principal constraints that the farmer faced in diversifying their livelihood which are public and institutional constraint; educational and training constraint; climate and production constraint; trade, norms and religious believes constraint; and time and skilled labour constraint. The livelihood diversification of the farm household portfolio of activities is determined not only by asset portfolios but also having the skills, location, capital, credit and social connections. It was therefore recommended that there is need for expansion of rural infrastructure such as schools, pipe born-water, rural electrification and wireless telecommunication services by government and non-governmental organizations to achieve the goal of farm household livelihood security as well as rural development, need for establishment of Farmers' Training Centers in IFAD-VCDP Zonal offices so as to develop skills and ability of the farmers, Government and donor agencies should assist in connecting rural communities with all-weather roads in order to facilitate rural-urban

linkages and its economic implications by constructing and maintaining feeder roads, and also the government and non-government organizations

should intensify efforts on public, institutional, educational and climate policies so as to increase livelihood opportunities in the study area.

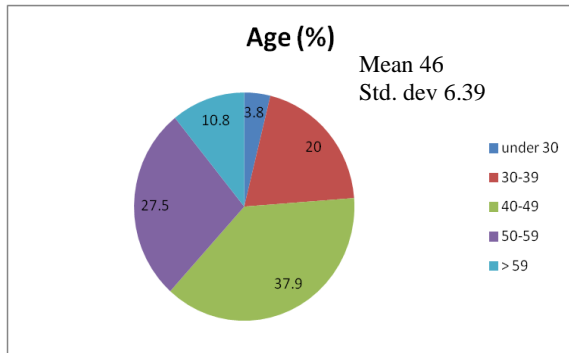


Figure 1: Age distribution of the farmers

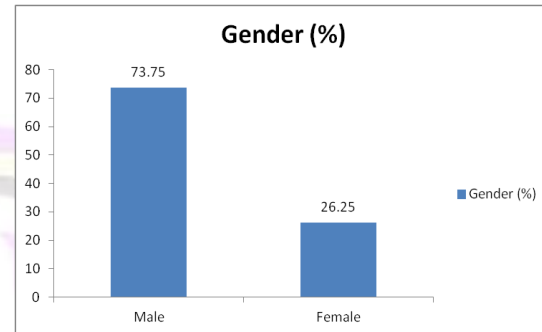


Figure 2: Gender distribution of the farmers.

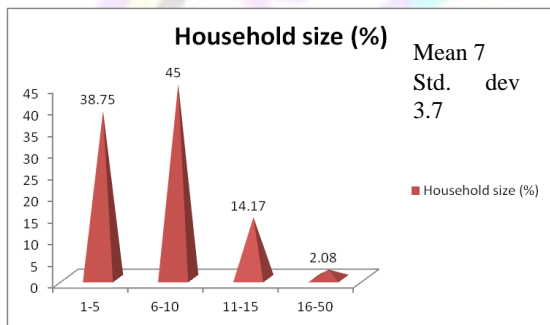


Figure 3: Household size of the farmers.

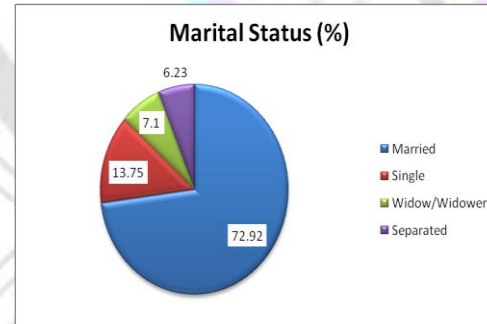


Figure 4: Marital status of the farmers

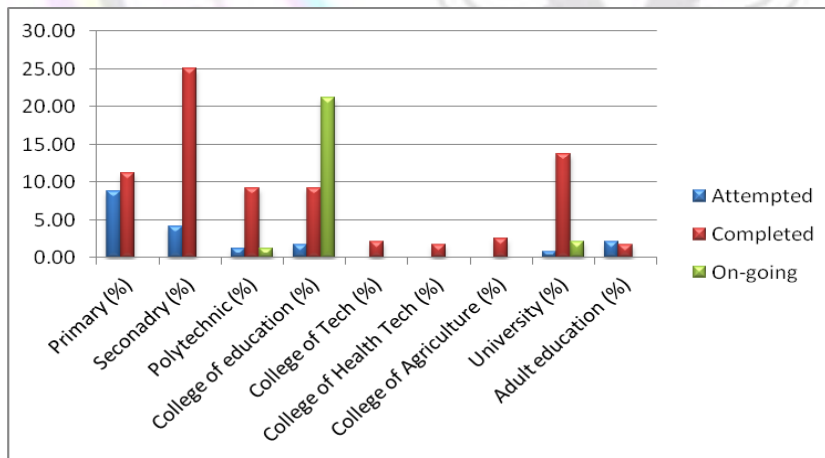


Figure 5: Educational attainment of the farmers

Table 1: Principal component analysis on constraints to livelihood diversification in Benue State

S/No	Constraints	Components*					Community
		Factor 1	Factor 2	Factor 3	Factor 4	Factor 5	
1	Inadequate infrastructure	0.831					0.729
2	Inadequate access to capital	0.825					0.747
3	Unstable price of transportation cost	0.791					0.663
4	Government policy	0.785					0.689
5	Inadequate credit facilities	0.771					0.731
6	No urban centre in proximity	0.638					0.693
7	Inadequate input delivery system	0.637					0.549
8	Lack of access to market	0.581					0.613
9	Poor transportation system	0.529					0.554
10	Lack of skill training and ability		0.853				0.793
11	Limited education		0.852				0.788
12	Rainfall variability			0.882			0.818
13	Declining farm size			0.770			0.717
14	Shortage of animal feed			0.624			0.568
15	Restriction on trade and movement				0.796		0.720
16	Norms and religious believes				0.585		0.546
17	Shortage of time					0.662	0.594
18	Inadequate skilled labour.					0.650	0.503
	Percentage (%) of total variance	31	16	7.8	5.6	4.6	

Source: Field survey, 2018.  
Extraction method: Principal Component Analysis,  
Rotation method: varimax with Kaiser Normalization.

**Table 2. Reliability analysis for the scale and factors retained**

Construct	Number of variables	Cronbach's alpha
Overall scale	18	0.877
Factor 1	9	0.906
Factor 2	2	0.826
Factor 3	3	0.806
Factor 4	2	0.756
Factor 5	2	0.749

Source: Field survey, 2018.

## REFERENCES

- Akinagbe, O. M. (2010). Constraints and strategies towards improving cassava production and processing in Enugu North Agricultural Zone of Enugu State, Nigeria. *Bangladesh Journal of Agricultural Resources*, 35(3), 387-394.
- Anselm, A. E., & Taofeeq, A. A. (2010). Determinants of Women's contribution to farming decision in cocoa based agroforestry households of Ekiti State, Nigeria. *Field Action Science Reports*, 4(1), 1-7.
- Appelhans, T., F. Detsch, C. Reudenbach & S. Woellauer (2018). mapview: Interactive Viewing of Spatial Data in R. R package version 2.5.0. <https://CRAN.R-project.org/package=mapview>
- Ardakani, S. R., Ansari, A., & Ardakani, M. R. (2012). Organizational Climate and Commitment. *Research*, 4(12), 1-3.
- Atagher, M. M., & Okorji, E. C. (2014). Factors that enhance or reduce productivity among



- cassava women farmers in Benue State, Nigeria. *Journal of Agriculture and Veterinary Science*, 7(5), 7-12.
- Awoniyi, O. A. & Salman, K. K. (2012). Non-Farm Income Diversification and Welfare Status of Rural Households in South West Zone of Nigeria. International Food Policy Research Institute (IFPRI) Paper. Pp. 1-14.
- Ayele, T. J. (2008). Livelihood adaptation risks and vulnerability in rural Wolaita, Ethiopia. PhD Thesis submitted to Department of International Environment and Development Studies, Norwegian University of life Science, Norway.
- Benue State Agricultural & Rural Development Authority (BNARDA) (1998). Impact of Benue State Agricultural and Rural Development Authority on Agriculture and Rural Development in Benue State, BNARDA, Makurdi, Nigeria.
- Cheng, J., B. Karambelkar & Y. Xie (2018). leaflet: Create Interactive Web Maps with the JavaScript 'Leaflet' Library. R package version 2.0.1. <https://CRAN.R-project.org/package=leaflet>
- Chong, K. R., Yap, B. C., & Mohammed, Z. (2013). A study on the application of factor analysis and the distributional properties of financial ratio of Malaysian companies. *International Journal of Academic Research in Management(IJARM)*, 2(4), 83-95.
- Ellis, F. (2000). *Rural livelihoods and Diversity in developing countries*. London: Oxford University Press. Pp. 1-10.
- Ewebiyi, I. O., & Meludu, N. T. (2013). Constraints to livelihood diversification among rural households in Southwestern Nigeria. *Global Approaches to Extension Practice: A Journal of Agricultural Extension*, 9(1)11-20.
- Hussein, K., & Nelson, J. (2014). 'Sustainable Livelihoods and Livelihood Diversification' IDS Working Paper 64.
- Intergovernmental Panel on Climate Change (IPCC) (2014). Climate variability, Impacts, Adaptation, and Vulnerability. Working Group II, Fifth Assessment Report Phase I Report Launch, 31 March 2014.
- Kahle, D. & H. Wickham (2013). ggmap: Spatial Visualization with ggplot2. *The R Journal*, 5(1), 144-161. URL <http://journal.r-project.org/archive/2013-1/kahle-wickham.pdf>
- Kaiser, H. F. (1958). 'The Varimax criterion for analytic rotation in factor analysis'. *Psychometrika*, 23(1), 187-200.
- Krejcie, R. V. & Morgan, D. W. (1970). Determining Sample Size for Research Activities. *Educational and Psychological Measurement*, 30(1), 607-610.
- Mabe, F. N., Sienso, G., & Donkoh, S. (2014). Determinants of choice of climate change adaptation strategies in Northern Ghana. *Research in Applied Economics*, 6(4), 75-94.
- Mohammed, S. C., Rabiul, I., & Zahurul, A. (2013). Constraints to the development of small and medium sized enterprises in Bangladesh: An empirical investigation. *Australian Journal of Basic and Applied Sciences*, 7(8), 690-696.
- National Population Commission (NPC) (2006). Population Data in Nigeria. Retrieved on 20<sup>th</sup> February, 2017 from <http://www.population.gov.ng/population-data-in-Nigeria>
- Okere, C. P., & Shittu, A. M. (2012). Patterns and Determinants of Livelihood Diversification among Farm Households in Odeda Local Government Area, Ogun State, Nigeria. Paper Presented at the Nigerian Association of Agricultural Economist Conference held at Obafemi Awolowo University, Ile-Ife between 25-27 September, 2012. Theme: Agriculture in the National Transformation Agenda: The Policy Mix.
- Ozor, N., Madukwe, M. C., Onokala, P. C., Enete, A., Garforth, C. J., Eboh, E., Ujah, O. & Amaecchina, E. (2010). A framework for agricultural adaptation to climate change in Southern Nigeria. A development partnership in higher education (DeIPHE) 326 project executive summary supported by DFID and implemented by British Council, Enugu: African Institute for Applied Economics.
- Pallant, J. (2005). *SPSS survival manual: a step by step guide to data analysis using SPSS for Windows (Version 12)*. Open University Press.
- Pebesma, E. (2018). sf: Simple Features for R. R package version 0.6-3. <https://CRAN.R-project.org/package=sf>
- Sallawu, H., Tanko, L., Coker, A. A. A., & Sadiq, M. S. (2016). Livelihood and income diversification strategies among rural farm households in Niger State, Nigeria. *Asian Journal of Agricultural Extension, Economics & Sociology*, 11(4), 1-11.
- Wickham, H. (2017). tidyverse: Easily Install and Load the 'Tidyverse'. R package version 1.2.1. <https://CRAN.R-project.org/package=tidyverse>

Zigale, T. T. (2016). Constraints of pastoral and agro-pastoral livelihood diversification in Eastern Ethiopia: The case of Mieso District, Oromia Regional State. *International Journal of Sciences: Basic and Applied Research*, 26(3), 110-119.



# GROWTH AND SURVIVAL OF WILD SAROTHERODON GALILAEUS AND COPTODON ZILLII RAISED IN A HAPAS-IN-POND SYSTEM

By

<sup>1\*</sup>Ibrahim, A., <sup>2</sup>S. L. Lamai, <sup>3</sup>S. M. Tsadu, <sup>4</sup> S. J. Oniye.

<sup>1\*,2,3</sup>Department of Water Resources, Aquaculture and Fisheries Technology, Federal University of Technology, Minna, Niger State, Nigeria.

<sup>4</sup> Department of Biological Science, Faculty of Science, Ahmadu Bello University, Zaria, Nigeria.

\*Corresponding Author: [a.ibrahim@futminna.edu.ng](mailto:a.ibrahim@futminna.edu.ng), GSM: 08124081135; 08060494372.

## ABSTRACT

*Growth and survival of the Cichlids: S. galilaeus and Tilapia zillii (weighing: 14.10 -110.00 g and 71.10 - 80.70 g) recruited from Tagwai dam were studied in a hapas-in-concrete pond culture system for 24 week, with a view to adapting the wild specimens for aquaculture. Thirty samples of S. galilaeus and C. zillii (15 samples for each species) were studied. The species had no significant difference ( $p>0.05$ ) in survival rates (27% and 33% for S. galilaeus and C. zillii). Growth patterns were positively allometry ( $b>3.0$ ) with correlation coefficients ( $r$ )  $> 0.9$  for both species, indicating strong length-weight relationship. Also, K. factor was  $> 3.0 \text{ g/cm}^3$  for both species. The study identified the stress sensitivity of the species to handling and pond condition. The positive allometry growth pattern exhibited by the specie is ideal for their fusiform shape. However, greater growth performance (weight gain) was recorded with S. galilaeus at 5% confidence level ( $p<0.05$ ). Furthermore, the growth responses are indices of their differential aquaculture potentials for sustainable fisheries. Nevertheless, the need to devote researches to effective management of natural fishery resource as well as a holistic management study of the growth, survival, breeding and feeding of the species under pond condition were recommended to provide comprehensive information on the species .*

**KEYWORDS:** Growth, Survival, wild, *Sarotherodon galilaeus*, *Coptodon zillii* and Hapa-in pond System

## INTRODUCTION

Tilapias are indigenous to Africa, however, interest in their aquaculture potentiality made their distribution virtually worldwide in the last five decades. Initial enthusiasm for the species was due to their suitable for subsistence fish farming in developing countries: several species are herbivorous, easily breed in small ponds, for their all-devouring feeding habit and for being sufficiently sturdy species for culture and are highly resistant to poor water quality variation (Meyer, 2002; Atama, *et al.*, 2013). They have however, become important components in subsistence fisheries for hundreds of decades, and are being reported as the most important aquaculture species in the world today, next only to carps, and also as the most important aquaculture species of the twenty-first century (Shelton, 2002; WorldFish, 2003; Gupta and Acosta, 2004). Furthermore, Tilapias are regarded as mouldable fish species because their growth and maximum obtainable size can be seriously influenced by the physical and biological composition of their environment (Olurin and Aderibigbe, 2006).

Several works have explored the Cichlid species including the aspects of the ecology and biology (Ikomi and Jessa, 2003; Olukolajo and Ayo-Olalusi, 2009) growth, mortality and age (Faunce *et al.*, 2002), ponderal index (Fagade, 1983; Arawomo, 1982; Anene, 2005) among others. Nevertheless, the growth and survival of wild *S. galilaeus* and *C. zillii* in pond (especially those from the Tagwai dam) has remained a dream to be realized. According to Telethon (2014), the emerging acceptance of tilapia among people and the ever-growing need for increased food production, calls for alternative in inter-specific diversification of aquaculture through the incorporation of wild native tilapia species in aquaculture. moreover, the declining supply from capture fisheries and the ever-increasing demand for fish have further buoyed the need for inquest into the cultural potentials of these species from the local river system. On this note therefore, this study was an attempt to bridge the knowledge gap with regard the growth and survival of native *S. galilaeus* and *C. zillii* from Tagwai Dam Reservoir in pond so as to provide useful information for proper management of the strains.



## Materials and Methods

**Recruitment site:** Fish samples were recruited from Tagwai dam (Figure 1), in Tagwai village, Niger State, northcentral Nigeria. The dam lies between latitudes 9° 33'N and 9° 37'N and longitudes 6° 39'E and 9°42'E (Akinrinmade, *et al.*, 2012). It is an earth filled dam, initiated by the Niger State Government to augment the source of raw water supply for the Chanchaga water treatment plant (Minna Water Supply Scheme, 1992). The dam has a crest height of 25m and it is 1.8km long with 28.3 million cubic meter volume, and serves for fisheries, recreation, wild life conservation and social upgrading purposes. Inhabitants around the Dam are predominantly artisanal Fishermen.

### Experimental site, facilities and design:

The experiment was conducted at the Water Resources, Aquaculture and Fisheries Technology, Department Teaching and Research Farm, Federal University of Technology, Minna, Nigeria. It was conducted in hapas-in-concrete pond system. The system comprised a concrete pond and six (6) net hapas made of 0.5" mesh size net woven on a square cylindrical plastic pipe. The pond and hapas were of 10 x 5 x 1.5m and 1 x 1 x 1m dimensions respectively.

The study was conducted using a completely randomized block design. The design comprised two experimental units: *S. galilaeus* and *C. zillii* and each combination of a single factor was repeated in triplicates.

**Pond fertilization:** This was done in accordance with the methods adopted by the National Agricultural Extension Liaison Services (2003) and Adigun (2005) to stimulate the production of natural fish food, using organic manure (poultry droppings) in pond at 0.1kg/m<sup>2</sup>. Thereafter, the same rate was applied for weekly fertilization throughout the 24-week experimentation.

### Recruitment and transportation of experimental fishes

A total of thirty (15 samples each for *S. galilaeus* and *T. zillii*) were recruited in the morning from Tagwai Dam, using Malian trap. The fishes were held in two separate hapas in the dam: one Hapa for each species until evening when they were removed and transferred to the experimental site. The samples were transported to the experimental site in oxygenated transparent polythene bags with water. Transportation water was prepared with addition of 8 g/L (0.8 %) salt as adopted by (William, 2014).

### Analysis of water quality parameters

Water samples collected from Tagwai dam during recruitment and the biweekly samples from the experimental pond were analyzed for temperature, dissolved oxygen (DO) concentration, pH and conductivity using mercury-in-glass Mercury bulb thermometer (Gallenkamp, England) 0-100, DO meter (Model YSI 54A), pH meter (Hannah model) and Conductivity Meter (WPACMD200) respectively. The transparency of the water samples was also monitored using secchi disc as adopted by Adigun (2005).

### Stocking of experimental fish samples

Stocking of the experimental fishes was done between 17:30 hrs and 18:30 hrs. Thirty tilapia samples (fifteen specimens for each species) were randomly distributed into six hapas in triplicates each (five specimens per hapa).

### Feeding of experimental fishes

Supplemental feed: "MULTI FEED" was provided by manual feeding at 10 % body weight twice daily (morning and afternoon) throughout the 24week study.

### Cumulative survival

The cumulative survival and survival rate were calculated as follows:

Cumulative survival was computed as:

$$\text{Survival} = N_0 - N_1$$

Where  $N_0$  = Number alive initially (at time  $t_0$ ) and  $N_1$  = Number alive at time  $t$

### Morphometric measurement of the experimental fishes

Morphometric parameters of the experimental fishes were measured on alternate weeks (every 2week). Samples from each hapa were sampled by taking their body weight, total length and standard length. The total length of each fish (distance from the tip of snout to the tip of the caudal fin) and the standard length (distance from the tip of snout to the posterior end of the caudal peduncle) were read to the closest 0.1 cm with a meter rule. Weight of each sample was read to the closest 1.0 g using top-loading Metler balance.

### Growth performance of experimental fishes

Growth performance of the experimental fishes were determined through: growth rate, growth pattern and condition factor as indices.

### Growth

The growth rate of the specimen was calculated as:

$$\% \text{ GR} = \frac{WF - W1}{W1} \times 100$$

Where, % GR = percentage growth rate, WF = final weight and W1 = initial weight

### **Growth pattern and condition factor**

Growth pattern was estimated by the equation:

$$W = aL^b \text{ (Pauly, 1983)}$$

Where, W = weight (g), L= standard length (cm).

The length-weight relationship (LWR) was expressed by the equation:

$$\text{Log weight} = \text{Log } a + b \text{ Log length}$$

Where 'a' and 'b' are constants of regression.

The condition factor was computed applying the Formula:

$$K = [100 W] / L^3 \text{ (Bannister, 1976).}$$

Where K = condition factor, W =weight (g), and L = standard length (cm)

### **Data analysis**

Weight gain, increase in lengths were analyzed via paired T-Test analysis with IBM SPSS Statistics 23. The relationship between pairs of variables (length-weight relationship) and their linear equation were analyzed with Linear regression for each species. The significance of the relationship was determined with regression table.

## **RESULTS**

### **Water quality parameters of Tagwai dam reservoir and the experimental pond**

The results of the quality parameters of water samples taken from Tagwai Dam during recruitment and the experimental pond during stocking and sampling are presented in table 1. In the results, the temperature and dissolved oxygen of water samples from Tagwai dam and the experimental pond vary slightly. The variations were however, not significant ( $P > 0.05$ ) between the sites. Only pH in the experimental was significantly higher ( $p < 0.05$ ).

### **Growth performance and survival of *S. galilaeus* and *C. zillii***

Introduction of wild samples of the species into captivity caused low weight gain, although, their lengths continued to increase (Table 1). Analysis of variance revealed no significant difference in initial weight ( $P > 0.05$ ), weight gain ( $p > 0.05$ ) standard length ( $P > 0.005$ ) and mean percentage survival ( $p > 0.05$ ) between the species. Nevertheless, after 24 weeks in pond condition (hapas-in-pond), the mean final weights of the fishes were observed to be significantly different ( $P > 0.05$ ) (Table 1).

### **Growth pattern and condition factor of *S. galilaeus* and *C. zillii***

The growth pattern of *S. galilaeus* and *C. zillii* inferred from the regression of natural logs of the weights plotted against the natural log of the lengths showed positive allometric exponent 'b' ( $b > 3.0$ ) values 5.5044 and 3.19 with correlation co-efficient values: 0.93 and 0.97 for *S. galilaeus* and *C. zillii* respectively (Table 3). The correlation coefficient ( $r^2$ )

indicated strong length-weight relationship of the both species.

The table also showed 3.07 and 3.45 as values of the condition factor which are positive allometric values for *S. galilaeus* and *C. zillii*, indicating positive conditions of the species.

### **Discussion**

The dissolved oxygen, pH, conductivity, transparency and temperature of water in Tagwai dam and the experimental pond were found to be within the benchmark standard ranges for fish culture (Costa-Pierce, 2003; Fish Base, 2008; Bhatnagar and Devi, 2013). Despite significant variability ( $P < 0.05$ ) in the quality parameters water samples from the two sites, the levels remain within acceptable ranges (Bhatnagar and Devi, 2013). This emphasis is crucial in the face of verifiable assertions such as the one of Bhatnagar and Devi (2013), who maintained that Fishes are not resistant to every change in their surroundings. A sudden fluctuation above or below allowable levels would have physiological consequences. Such fluctuation makes fish vulnerable to stress and, the greater and faster the intensity, the greater the stress.

The low percentage survival of the experimental fishes is an index of the stress sensitivity of the species. This is evident in the occurrence of mortality just few days after introduction of the samples into the experimental facility. This agrees with Liao and Huang (2000), in their report that, some sensitive species are not easily adaptable to culture environment because, a composite of nutritional, immunity and endocrine disorder may cause serious stress and eventual death of sensitive species. However, the degree of susceptibility to stress varied amongst the species. In this regard *C. zillii* performed better than *S. galilaeus* and this may be attributed to restiveness of the *S. galilaeus* during introduction to the pond. Restiveness, as reported by Zeder (2012), has the greatest and general impact on domestic animals selected for manipulation to increase adaptability of wild species to artificial conditions.

Growth in fish is a trait of economic importance in aquaculture. Hence, growth was taken as a major factor of comparison of the two species. In this regard the species showed differential responses to pond condition. This is expressed in the mean weight gain of *S. galilaeus* ( $76.62 \pm 26.48$ ) and *C. zillii* ( $43.92 \pm 17.08$ ) and may attributable to genetic variation, response to feed and differential response to pond environment.

The growth pattern of *S. galilaeus* and *C. zillii* in this study were positive correlation coefficient ( $r = 0.93$ ,  $r = 0.97$  and  $r = 0.98$  and  $0.95$ ). That is, weight increase was positively correlated to length. Exponents of regression ( $b > 3.0$ ) shows allometric growth pattern for *S. galilaeus* and *C. zillii*. This signifies that,



the tilapias got heavier for their length as they grow (Oniye, *et al.*, 2006). Positive allometric growth was considered an ideal growth pattern for the tilapia species owing to their fusiform body shape. It is ideal, when isometric value of  $b=3$  for fishes that maintain three-dimensional equivalences (Oniye, *et al.*, 2006). The variation in the regression exponent  $b$  of the species has confirmed the report of Saha, *et al.*, (2009) that 'b' value dissimilarities between fishes is dependent on their species, sex, food habits and level of maturity.

Variation in the values of condition factor (K) between *S. galilaeus* and *T. zilli* indicated that the species responded somewhat differently to the same condition. The variation may have been influenced by the species genetic variability in response to the pond environment. Atama, *et al.* (2013) noted that condition factor is not constant for species or population over a time interval and might be influenced by both biotic and abiotic factors such as phytoplankton abundance, predation, water temperature and dissolve oxygen concentrations, feeding regime and state of gonadal development among others which may not equally favour the survival of all the species in the ecosystem.

#### **Conclusion**

Sequel to the findings of the study, the following conclusions were drawn:

*S. galilaeus* and *C. zillii* survived below average in the experimental facility. Comparatively, *C. zillii* showed better adaptability with respect to survival in captivity. In growth performance (weight gain), the species recorded varying degrees of successes with *S. galilaeus* showing better response. The index for the well being of the samples showed that the experimental condition was favourable to both species.

Therefore, the research established that both *S. galilaeus* and *C. zillii* from Tagwai dam adapted to the pond culture environment at varying degrees of successes in growth (weight gain and growth pattern) and survivorship.

#### **Recommendation**

This study only assessed the growth performance and survival of wild *S. galilaeus* and *C. zillii* strains from Tagwai Dam Reservoir under pond condition. It may be interesting if further study is conducted to also include their feeding behaviours (with respect to artificial feeds) and breeding. More researches towards effective management of the natural fisheries resources should be encouraged to safeguard the resource and enhance sustainability of production, supply and availability of fish to local consumers.

#### **REFERENCES**

- Adigun, B. A. (2005). Water quality management in aquaculture and freshwater Zooplankton production for use in fish hatcheries. 1<sup>st</sup> Edition, Alabi Printing Production Ltd. Ilorin, pp 26.
- Akinrinmade, A. O. Ibrahim, K. O. and Abdurrahman, A. (2012). Geological investigation of Tagwai Dams using Remote Sensing Technique, Minna Niger State, Nigeria.
- Anene, A. (2005). Condition factor of four cichlid species of a man-made in Imo state, south eastern Nigeria. *Turkish Journal of Fisheries and Aquatic Science*. 5, 43 - 47.
- Arawomo, G. A. O. (1982). The growth of *Sarotherodon niloticus* (L): the plankton and fishes of a tropical creek in South-West Nigeria. *Turkish Journal of Fisheries and Aquatic Science*. 7 (2), 105 - 114.
- Atama, C. I., Okeke, O. C. Ekeh, F. N. Ezenwaji, N. E. Onah, I. E. Ivoke N. And Eyo, J. E. (2013). Length-weight relationship and condition factor of six cichlid (cichlidae: perciformis) species of Anambra river, Nigeria. *Journal of Fisheries and Aquaculture*. 4 (2), 82-86.
- Bannister, J. V. (1976). The length-weight relationship, condition factor and gut contents of the dolphin fish *Coryphaena hippurus* (L) in the Mediterranean. *Journal of Fish Biology*. 9, 335 – 338.
- Bhatnagar, A. and Devi, P. (2013). Water quality guidelines for the management of pond fish culture. *International Journal of Environmental Sciences*. 3(6), 1980-2009.
- Costa-Pierce, B. A. (2003). Use of Ecosystems Science in Ecological Aquaculture. Bull. Aquaculture Association. Canada pp.103.
- Fagade, S. O. (1983). The biology of *Chromidotilapia guntheri* from a small lake. *Archiv fur Hydrobiologie*. 97, 60 - 72.
- Faunce, C. H. Patterson, H. M. and Lorenz, J. J. (2002). Age, growth and mortality of the Mayan cichlid (*Cichlasoma urophthalmus*) from the South-eastern everglades. Fishery Bulletin. 100, 42 - 50.
- FishBase (2008). Ecology of *Coptodon zillii*. National Biological Information Infrastructure (NBII) & IUCN. ManaakiWhenua-Landcare Research and the University of Auckland.



- Retrieved on March 30, 2015 from FishBase website: [www.fishbase.org](http://www.fishbase.org)
- Gupta, M. V. and Acosta, B. O. (2004). A review of global tilapia farming practices. In: Wilkinson, S. (ed), Aquaculture – an ecologically sustainable and profitable venture, NACA, Bangkok pp. 7 – 12.
- Ikomi, R. B. and Jessa H. O. (2003). Studies on aspects of the biology of *Tilapia mariae* (Boulenger, 1899) (Osteichthyes Cichlidae) in Ethiopie River, Niger delta, Nigeria. *African Journal of Agricultural Research*. 38(2): 255 - 264.
- Journal of Environment*. 1 (1), 26-32.
- Liao, I. C. & Huang, Y. S., (2000). Methodological approach used for the domestication of potential candidates for Aquaculture. Recent advances in Mediterranean Aquaculture Finfish Species Diversification. Zaragoza, CHEAM: pp 97-107.
- Meyer, D. E. (2002). Technology for successful small-scale tilapia culture. CRSP in: D. (ed), 6to Simposio oamericano de acuacultura Proceedings: Tilapia Sessions, Tegucigalpa, Honduras, pp. 97-106.
- Minna Water Supply Scheme, (1992). Minna Water Supply – long term studies. Niger State Water and Sanitation Board. Report prepared by Prime Service Engineers, Enugu.
- National Agricultural Extension Liaison Services (2003). Fish pond fertilization techniques. Extension Bulletin No. 153, Fisheries Series No. 8. Ahmadu Bello University, Zaria.
- National Agricultural Extension Liaison Services (2003). Fish pond fertilization techniques. Extension Bulletin No. 153, Fisheries Series No. 8. Ahmadu Bello University, Zaria.
- Olukolajo, S. O. and Ayo-Olalusi, C. I. (2009). Aspects of ecology and biology of the cichlid, *Tilapia mariae* from two adjacent low-brackish water lagoons in Nigeria. *African Journal of Agricultural Research*. 4 (5), 474-483.
- Olurin, K. B. and Aderibigbe, O. A. (2006). Length-Weight Relationship and condition factor of pond reared juvenile *Oreochromis niloticus*. *Journal of Zoology*. 1, 82-8.
- Oniye, J., Adebole, D. A., Usman S. K. and Mapo, J. k. (2006). Some aspects of biology of *Protopterus annectens* (Owen) in Jachi dam near Katsina, Katsina state, Nigeria. *Journal of Fisheries and Aquatic Sciences*. 1 (2), 136 – 141.
- Pauly, D. (1983). Length-converted catch curves, a powerful tool for fisheries research in the tropics. *Part 1. ICLARM Fishbyte* 192, 9 – 13.
- Saha, S. N. Vijayanand, P. and Rajagopal, S. (2009). Length-weight relationship and relative condition factor in *Thenus orientalis* (Lund, 1793) along east coast of India. *Current Research Journal of Biological Sciences*. 1 (2), 11-14.
- Shelton, W. L. (2002). Tilapia culture in the 21st century. In: Guerrero, R. D. III and Guerrero-Del Castillo, M. R. (Eds.). Proceedings of the International Forum on Tilapia farming in the 21st Century, Philippine Fisheries Association Inc. Los, Banos, Laguna, Philippines, 1-20 pp.
- Telethon, F. (2014). Levels of domestication in fish: implications for the sustainable future of aquaculture. *Fish and Fisheries Journal*. 15 (2), 181–195.
- William, A.W. (2014). Using salt to reduce handling stress in channel catfish. *World Aquaculture*. 26 (3), 80 - 81.
- WorldFish (2003). A selected bibliography on tilapia (Pisces: Cichlidae). WorldFish centre. Jutaprint, Penang, 3 (1), 200 - 209.
- Zeder, M. A. (2012). Pathways to animal domestication. In: Bettinger, *et al.* (eds), Biodiversity in Agriculture, Cambridge University Press, Cambridge pp. 227-229.

**Table 1: Mean water quality parameters of Tagwai dam and the experimental pond**

Site	DO (mg/L)	pH (mg/ L)	Con. (µmhos/cm)	Transp. (cm)	Temp. (°c)
Tagwai Dam	8.04±0.11 <sup>a</sup>	6.79±0.10 <sup>a</sup>	58.50±8.24 <sup>a</sup>	36.00±2.00 <sup>a</sup>	26.00±1.26 <sup>a</sup>

Experimental pond	7.65±0.39 <sup>a</sup>	7.99±0.04 <sup>b</sup>	163.33±4.36 <sup>a</sup>	28.00±0.46 <sup>a</sup>	26.67±0.82 <sup>a</sup>
-------------------	------------------------	------------------------	--------------------------	-------------------------	-------------------------

Means within a row with the same letter script are not significantly different at 5 % probability.

Con. = conductivity, Transp. = transparency, Temp. = temperature

**Table 2: Growth parameters of wild *S. galilaeus* and *C. zillii* in hapas-in-concrete pond system**

Growth parameter	Species	
	<i>S. galilaeus</i>	<i>C. zillii</i>
Initial length (cm)	13.00±1.15 <sup>a</sup>	13.28±0.29 <sup>a</sup>
Final length (g)	15.50±2.10 <sup>a</sup>	12.55±2.50 <sup>a</sup>
Initial weight (g)	43.20±0.26 <sup>a</sup>	40.96±0.19 <sup>a</sup>
Final weight (g)	107.35±20.15 <sup>a</sup>	66.75±15.52 <sup>b</sup>
Mean weight gain (g)	64.15± 19.29 <sup>a</sup>	25.79±3.08 <sup>b</sup>
Mean survival (%)	33.33±0.33 <sup>a</sup>	40.00±0.33 <sup>a</sup>

Means within a row with the same letter script are not significantly different at 5 % probability.

**Table 3: Length-weight relationship and condition factor of *S. galilaeus* and *C. zillii***

Sample	No. of samples	a	b	b (SE)	r	K (±SD)
<i>S. galilaeus</i>	4	-10.421	5.5044	2.49	0.9302	3.07±0.28
<i>C. zillii</i>	5	-3.8918	3.1945	1.80	0.9673	3.38±0.11

# DEVELOPING INTELLIGENT WEED COMPUTER VISION SYSTEM FOR LOW-LAND RICE PRECISION FARMING

Olaniyi, O. M<sup>1,a</sup>., Daniya, E.<sup>2,b</sup>., Abdullahi, I.M<sup>1</sup>, Bala, J. A<sup>3</sup>., Olanrewaju, A. E<sup>1</sup>.

<sup>1</sup>Department of Computer Engineering, Federal University of Technology, Minna, Nigeria

<sup>2</sup>Department of Crop Production, Federal University of Technology, Minna, Nigeria.

<sup>3</sup>Department of Mechatronics Engineering, Federal University of Technology, Minna, Nigeria

<sup>a</sup>[mikail.olaniyi@futminna.edu.ng](mailto:mikail.olaniyi@futminna.edu.ng),

## ABSTRACT

Weeds infestation is one of the major problems facing rice production in Africa. Losses of rice caused by weeds yearly have been estimated at 2.2 million tons in Sub-Saharan Africa, the losses which are estimated at \$1.45 billion. Weeds reduce the economic value of rice by causing an increase in the cost of production. Concerns have been raised on the health implication of herbicides, weeds seed in food crop and their effect on the environment, therefore, leading to the need for site-specific means of herbicide application to target only the weeds and ensure minimal seed contamination. This paper addresses these problems by the use Faster Regions with Convolution Neural Network (faster R-CNN) and Fuzzy Logic Controller (FLC) to develop an intelligent weed recognition system for better yield and return of investment in rice production in Sub-Saharan Africa. Faster R-CNN is a type of Artificial Neural Network (ANN) which uses convolutional features to map obtained features from an input image in order to identify the region of interest from the bounding box drawn around the weed image. As of the time of this research, the faster R-CNN method provides a faster means for real-time recognition as compared to other methods of ANN. The result of the recognition will be fed into the FLC to control the volume and time of spraying of the herbicides in low-land rice precision farming. The successful development and pilot testing of the anticipated intelligent computer vision system for rice weed control is expected to provide a faster and more efficient means of weed management for low-land precision farming for better food security in Sub-Saharan Africa.

**KEYWORDS:** *Weed, Site-specific, Artificial neural network, Deep learning, Faster R-CNN, Fuzzy logic control, Food Security*

---

## INTRODUCTION

Rice (*Oryza sativa*), a plant species, is a seed of grass species grown as an annual plant. Rice is one of the world's three leading food crops and provides twenty per cent of the calories consumed worldwide by humans. It is one of the most consumed staple food among Africans and Asians, far more than half of the population of the world (Maclean, Hardy, & Hettel, 2013). Rice is an important staple food consumed by Nigerians. Rice is farmed in about 1.7 million hectares of the estimated 4.6 million to 4.9 million hectares' potential land for its production. The production environment for rice in Nigeria is the rain-

fixed (Warda, 2015). There are different constraints which affect rice productivity such as weed infestation, poor extension system, low yield, poor milling, and poor drainage (Nwilene *et al.*, 2008).

fed lowland, rain-fed upland, irrigated lowland, deep water/floating and mangrove swamp (Nwilene *et al.*, 2008).

There is three important periods of rice growth. The first is the vegetative phase in which foundation is laid and most farm operations are accomplished. The second is the reproductive phase which deals with building up stores, the panicles of the rice and the leaves develop to flowers. The third stage is the maturity phase when the flowers are fully matured and rice is ready for harvest. The difference in all the rice varieties of the world is the vegetative phase as the other two phases reproduction and maturity are

Weed is any plant that grows in an unwanted place. Akobundu *et al.* (2016) suggested that human disturbance of natural way of vegetation to meet recreational and agricultural activities led to the idea of weed. Civility and increase in knowledge of the nature of weeds have led to the identification, study



and seeking of ways to control this notorious crop pest. No one weed is known by same local name so the botanical name was adopted to describe leaf form. The weed does not only affect yield but also affects the farmers by proportionate decrease and low return on investment in rice production, if not properly managed.

Weeds in rice plantation reduce the yield and quality of rice production by competing with the rice crop for nutrients, light and moisture needed for growth. Weeds, when not properly managed can cause an increase in harvesting, drying and cleaning costs. It can also lead to contamination of the seedling, therefore, undermining the profit which ought to be made on the rice (Odero and Rainbolt, 2011). To wrestle with this menace there is a need for these weeds to be identified, studied and control mechanism applied to them.

There is a need to remove the weed with minimum damage to the crop. Hand weeding is laborious and costly (Hansson and Ascard, 2002). The cost of labourers for a large farm takes a toll on the farmer. Labour shortages, illiteracy, ignorance, inputs and credits are major constraints for African farmers (Rodenburg and Johnson, 2009). Herbicides usage is one of the main ways which is adapted to weeds aside manual weeding. Celen *et al.* (2008) suggested that excessive use of these chemicals to control weed can cause environmental contamination which could lead to losses at harvest. Accurate information is needed to effectively remove or treat weeds in rice plantation. Precision farming (PF) is considered the best practical approach to achieve sustainable agriculture (Amin *et al.*, 2011). The necessity to meet the demand of the current population of the country at the least cost and having a high output for rice is the main focus of this paper's precision agricultural approach.

Computer vision is a branch of artificial intelligence based on the theory of machine learning, image processing and pattern recognition. It involves equipping the computer with cognitive ability to acquire, process, analyse, understand digital image acquired through cameras, extract features from it and make valid decisions based on the acquired images. Images acquired are enhanced, segmented and features extracted from the images are classified using classifiers such as Artificial neural networks,

servo vector machine or clustering methods (Rafael and Gonzalez, 2002).

Artificial Neural Network (ANN) is inspired by biological neural systems and learns over time based on prescribed data-set using processes like geospatial, multispectral techniques, and image processing techniques. While defining computing functions and distribution, the ANN sets out to look for the cost-effective and ideal way of arriving at a solution to a task (Technopedia, 2018). The Fuzzy Logic Controller is a type of fuzzy logic control based on verifiable observation of conventional statements of the system under control instead of quantitative terms. The relationship between input and output of the system under control is monitored by fuzzy logic. Fuzzy logic allows the emulation of human response and applies best-fit intelligence to the control data (Omega, 2018). It is applied in this study due to its inherent robustness to make the right decision in a precise scenario and its adaptability to changes in the environment like the presence of weed in rice farm production.

This research seeks to combine ANN, precisely Faster Regions with Convolution Neural Network (faster R-CNN), as a classifier and Fuzzy Logic Controller to develop an intelligent computer vision system, precisely, weed recognition and control system for managing weed infestation in low-land rice precision farming. The rest of this paper is organized as follows. Section II presents a review of related fundamental concepts and works, Section III discusses the proposed methodology, while Section IV concludes and opens the next directions of the research.

## LITERATURE REVIEW

This section reviews the different methods that have been adopted for weed recognition and control by researchers in literature.

## RICE DISTRIBUTION IN NIGERIA

Rice is a seed of grass species *Oryza sativa* or *Oryza glaberrima*. Rice is the third highest worldwide produced after sugar cane and maize and the world's second most important cereal crop after maize (AgroNigeria, 2014a). Rice provides 20% of the calories consumed worldwide by a human. Rice is monocot which is grown as an annual plant. About 480.3 million tons of rice is produced yearly, with

China being the largest producer in the world with a production of 206.51 million tons yearly (Statista, 2017). Nigerian rice is grown on 1.77 million hectares of lands. Rated on a social scale, rice can be ranked first because it is a global staple of most urban and rural area homes. Rice can be grown in every ecological zone, thereby making Nigeria great potential for its production (Ajala and Gana, 2015). Rice production has been relatively low in Nigeria due to ever-increasing the cost of fertilizers, tractor

use, insecticides, manual labour, herbicides, transportation of produce and manual labour (Ajala and Gana, 2015).

There are six ecological growing environments for rice which is shown in Table 1. These growing environments are upland, hydromorphic, rain fed lowland, irrigated low land, deep inland water and mangrove swamp (Rodenburg *et al.*, 2011). Figure 1 shows the characteristics of the rice-growing environment in Nigerian and Agro-ecological zones.

**Table 1: Summary of the rice-growing environment (Longtau, 2003).**

Type	Characteristics	Geographical spread
<b>Upland</b>	Rain-fed rice grown on free-draining fertile soils.  This is also called dry uplands.	Widespread, except coasts, high rain forests and Sahel.
<b>Hydromorphic</b>	Rain-fed rice grown on soils with shallow ground water table or an impermeable layer. This is also called wet uplands.	Very widespread at the fringes of streams and intermediate zone between upland and swamps of rivers in the Savannah.
<b>Lowland</b>	Rain-fed or irrigated rice in aquatic conditions or medium groundwater table. Water covers the soil completely at some stage during the cropping season. These are called shallow swamps or fadama	Very widespread from high rain forest to the the Sahel.
<b>Deep Inland Water</b>	Rain-fed rice grown on soils with deep water tables. The rice crop floats at some stage and harvesting may be done from a canoe. These are also called deep fadamas or flood plains	Found in the Sokoto-Rima Basin and Chad Basin, floodplains of the Niger, Benue, Kaduna, Gbako, Hadejia and Komadugu-Yobe.

<b>Mangrove Swamps</b>	Rice is grown at the coast or swamps of the high rain forest.	Coastal areas and Warri area in Delta state.
------------------------	---	--

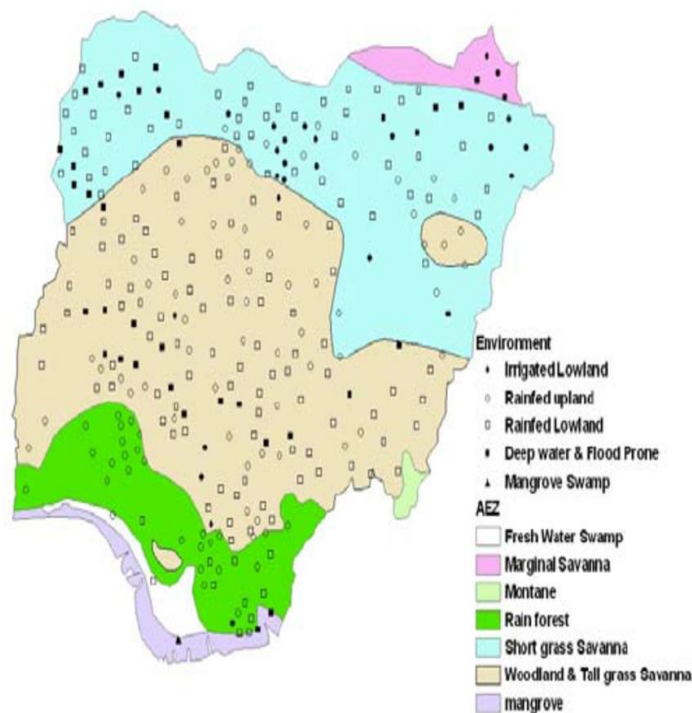


Figure 1: Map of Nigeria showing RGE and AEZ (Olaleye and Ogunkunle, 2009)

## WEED MANAGEMENT TECHNIQUES

Various techniques have been reported in literature for managing weeds as shown in Figure 2. The available techniques can be grouped into:

- i. Manual Techniques
- ii. Semi-Automated Technique
- iii. Automated Technique

### Manual Technique

This technique consists of physical control that is ecologically friendly. It involves the use of hand or hoes to manually remove weeds from rice farms. The technique also includes cultural methods which involve proper seedbed preparation, mulching, maintaining clean reapers and tools, planting good quality seeds, planting varieties that suit growing condition, fire clearance, early flooding, bush

following and shifting cultivation or combination of these methods (Odero and Rainbolt, 2011).

### Semi-Automated Technique

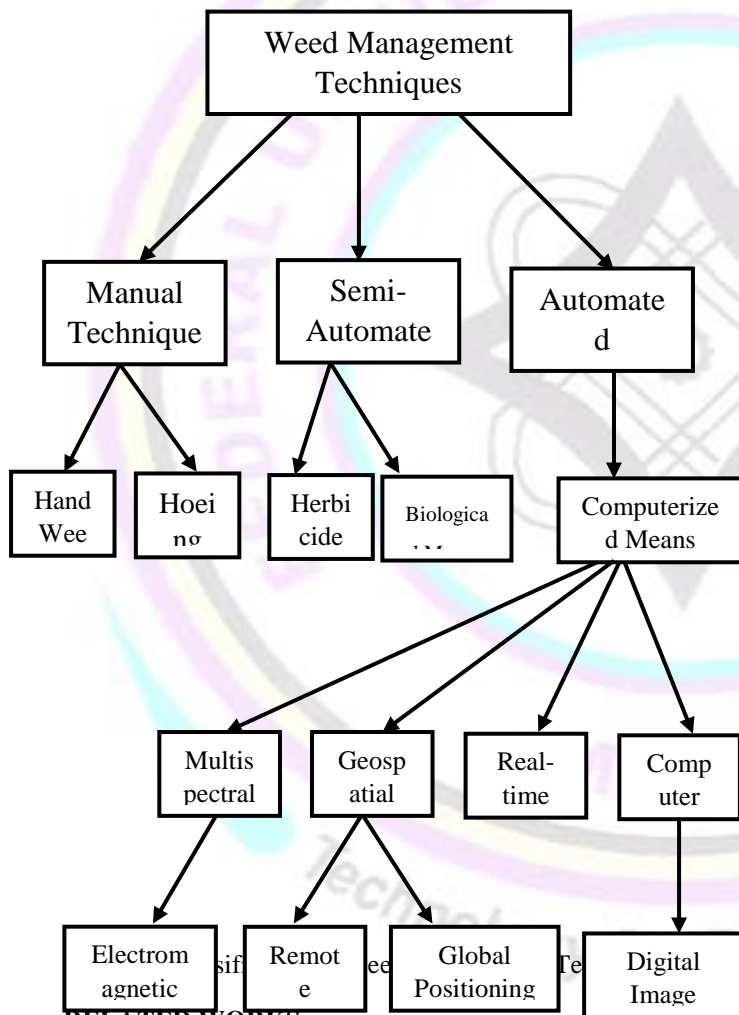
This technique consists of herbicide application and biological means of weed management. Though the Chemical method dominates this process, it involves the use of herbicides as another alternative to the cultural method in manual techniques (AgroNigeria, 2014b; Matloob *et al.*, 2014). Examples of herbicides used are Butachlor, Propanil, Tamarice TMPL, Ronstar TMPL and Risane as stated by IRRI. IRRI suggested that some of these herbicides be applied to farm 2-3 weeks after transplanting the rice while others applied as post-herbicide control. The type of herbicides applied depends on either it is pre-planting (before planting), pre-emergent (before weed come up in plants) or post-emergence (after weeds have grown with rice).



## Automated Technique

This technique consists of the use of computerized means to identify and control weeds on farmlands. The method involves, gathering information about the farms, storing the information, extracting features from them and then using the extracted features to make spraying decisions on the farmland. The devices from this approach can be mounted on tractors, drones or mini robots which are used on the farmland for weed control. These devices can be used inter-rows or intra-rows on the farmland. Automated method uses knowledge from machine

vision based on digital image processing techniques, real-time differential spraying, which uses near-infrared channels (Feyaerts and Van Gool, 2001; Gerhards and Oebel, 2006); geospatial and information technologies based on remote sensing and global positioning systems (Christensen, 2006), normalization vegetation index from near infrared, use of colour indices (Ribeiro *et al.*, 2005), visible spectrum image processing, broad-spectrum image processing and other methods of site-specific spraying based on use of optical sensors, such as detect spray (Felton and McCloy, 1992), and Spray vision (Felton, 1995) among others.



## RELATED WORKS

Tian (2000) proposed a method based on machine vision to recognise tomatoes seedlings from weed using environmental adaptive segmentation technique and knowledge-based vision system. Even though the system was able to accurately identify 65% to 78% of

the target crops and wrongly identify 5% of the weeds, it provides no means of control for the weeds identified. Similarly, Yang (2000) proposed a method based on back propagation **Artificial Neural network (ANN) model using colour indices features to distinguish young corn plants from weeds. The system was able to successfully**

**recognize 80% of the weeds but it does not provide the method for the weed removal.** Tellaeche *et al.* (2008) developed a vision-based method for weed identification based on Bayesian decision theory. The authors used a computer vision approach to detect and differentially spray weeds in the cornfield. The system used two main strategic processes; image segmentation and decision making based on Bayesian framework. Though the system was implemented on a tractor that does the differential spraying it does not provide means of continuous learning on the farmland.

Similarly, Odero and Rainbolt, (2011) used a well-prepared seedbed and cultural method to manage weeds in rice. By majorly using early flood, the system was able to suppress some non-aquatic weeds leaving the aquatic weeds to survive. The non-selective spraying of the farm can lead to herbicide wastage and incur more production cost. Also, Griepentrog *et al.* (2006) designed an autonomous intra row weeder for weed control based on GPS. The system simulated in MATLAB® has an accuracy of 80% and the field operation has an accuracy of 88% in weed removal. The system which was designed for upland with well-spaced crops to prevent damage from rotor blade which will not be applicable to low-land Rice farming. Pusphavalli and Chandraleka, (2016) proposed a robotic system that classifies weeds based on visual texture. The system uses knives for removing the weeds and this can damage the plant. The system consumes a lot of power and the weeds can regrow since they are not uprooted.

It is also imperative to review literature that works to reduce herbicide usage. Some of these methods that are based on site-specific spraying of weed infested areas include methods like detecting spray (Felton and McCloy, 1992), and spray vision (Felton, 1995) among others. These methods are based on optical sensors to reduce herbicide use by using reflectance to distinguish plants from the soil but these system does not differentiate between weeds and crops. Bossu *et al.* (2007) proposed a precision sprayer based on machine vision to distinguish weeds from plants using blob detection and Garbor filter but does not detect weeds in between rows. There are also

other existing methods that detect weeds in wheat, soya beans and maize with less accuracy in real life field application.

Based on the problems identified in the reviewed papers, which are inability to tackle aquatic weeds, high power consumption, herbicides wastage, non-removal method and inability to learn on the farmland, this paper proposes an intelligent weed recognition and control system for low-land precision rice farming using a faster R-CNN for real-time recognition of weeds and FLC for spraying decision making. The system identifies the weeds and applies the appropriate quantity of herbicide on the weeds.

## METHODOLOGY

### System Overview

Electronic components to be used for the development of the system are, raspberry pi3, Pi-Camera module, DC liquid pump, LEDs, buzzer, 2-way relay module, Switch button and the power supply. The camera module, push a button and power supply shall act as input to the microcontroller (Raspberry pi3) while the buzzer and liquid DC pump act as the output. After the data set has been obtained and the features of images of the weeds have been extracted for recognition, a Faster region with convolution neural network algorithm, a type of artificial neural network, which is a form of the deep neural network will be used for training the dataset. The trained network is stored within the programmed Raspberry pi3. The designed system which will be attached to a knapsack sprayer. The camera to be attached to the other components will be attached to the body of the knapsack. When the switch button is pushed to start the system, the system starts taking a real-time image of the farmland and discards them as soon as it discovers it is not a weed. Once the camera sees a weed it will draw a bounding box around it and signal the farmer via a buzzer to allow him to wait for spraying. The raspberry sends message to the pump, the message consists of the quantity of herbicide to spray and the time for the spraying based on a fuzzy logic calculation derived from the input of the size of the bounding box and the faster R-CNN calculation. The proposed architecture of the system and block diagram is shown in Figure 3 and Figure 4.

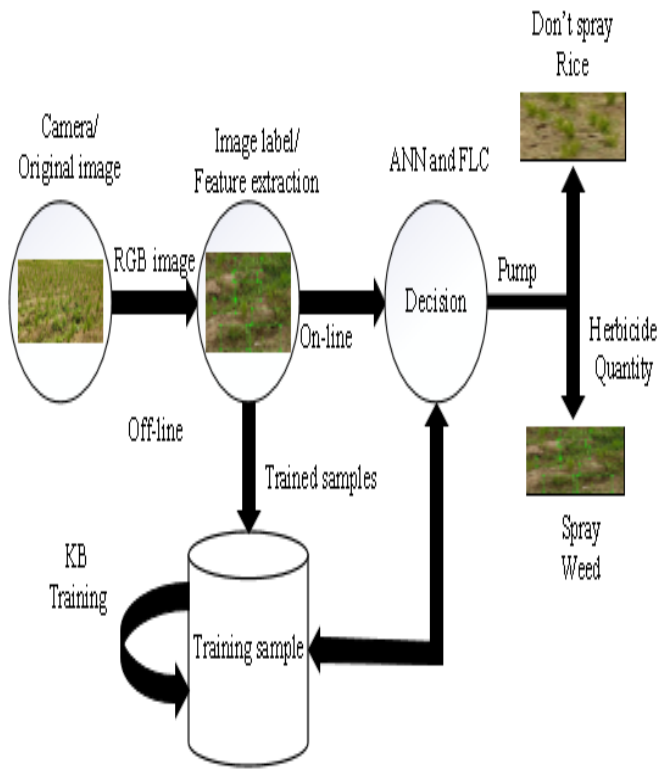


Figure 3: The Proposed architecture of intelligent weed recognition and control system

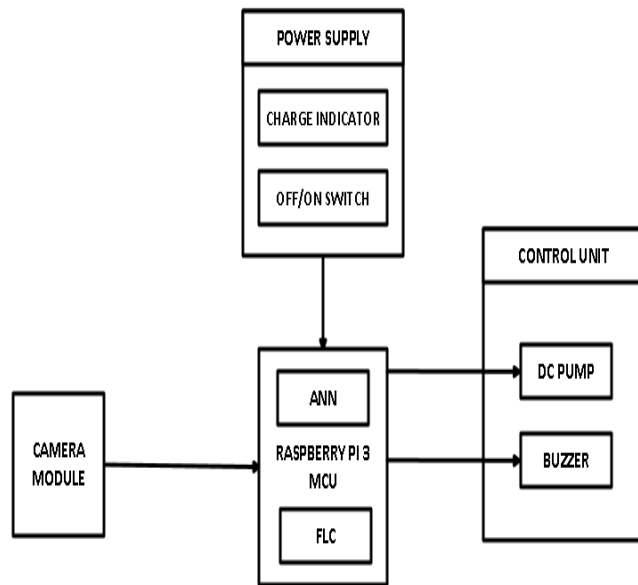


Figure 4: Block diagram of intelligent weed recognition and control system

### Image acquisition system

Images of sixteen (16) different most common weeds of low-land rice were acquired from Google server

and from the FUT Minna rice farm. Using the fatkum image downloader, an add-on on Google chrome



browser to download image batches from Google server. The images obtained were carefully scanned and any non-weed images were deleted from the ones downloaded. Two hundred images of rice with weed was taken from FUT Minna Farm. Figure 4 shows an

image of a FUT Minna rice farm with weed. The images from the school farm were taken with a 13 Megapixel tecno camon cx air camera with a resolution of 4160 X 3120 pixel with focus of 0.15 seconds.



Figure 4: Weed infested rice plantation obtained from Teaching and Research Field, FUT, Minna 18/05/2018.

### Data Preparation

This is the process of putting the data into a suitable form which makes it easier for the data to be used. This process is important so that the images can be in a suitable format which can be used as a data set to train an artificial neural network for image recognition. The images of weeds obtained from Google server were resized to the same size of 250 by 250 pixels to reduce the size, using Adobe Photoshop. A tool for data preparation called label image

(Labelling) was used to draw a rectangular bounding box around the weeds in the image and was labelled as a weed. The process is shown in Figure 5. The labelled image was saved in XML file format as a dataset for the training. A separate rectangular bounding box was drawn on the rice and labelled as rice, as many rice plants sighted in the image was labelled. The labelled image was saved in XML format as a dataset for rice.

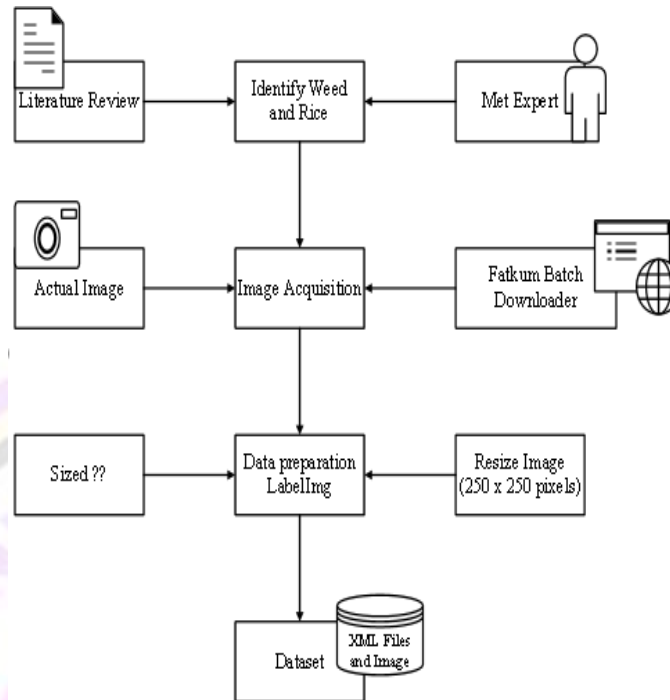


Figure 5: Dataset acquisition

### Training the Intelligent Weed Recognition m

#### Model

An online Graphics Processing Unit (GPU) (Paper Space) was obtained for training the model. In training the dataset, eighty per cent would be used for the training, ten per cent for testing and ten per cent for validation. Paper Space is an online platform that

gives limitless computing power in the cloud. The platform is used for deep learning, data exploration and gaming. GPU's are necessary for training deep learning models because they require a lot of computational power to run on, considerable hardware to run efficiently (Jenny, 2018). A deep neural network is an algorithm, the algorithm flow for training for creating a model for recognition is shown in Figure 6.

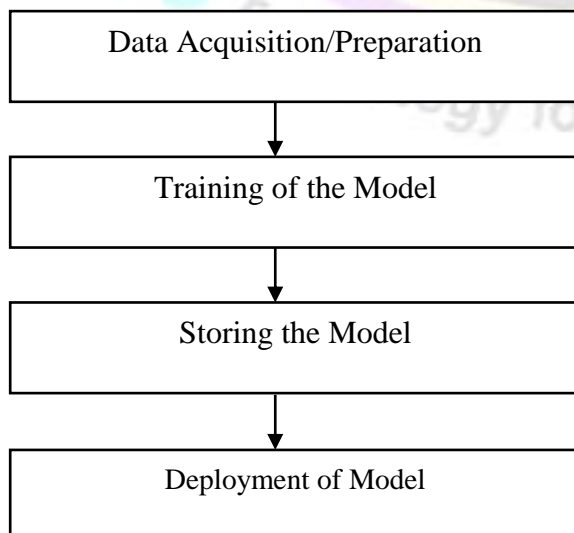


Figure 6: Weed recognition model using deep learning.

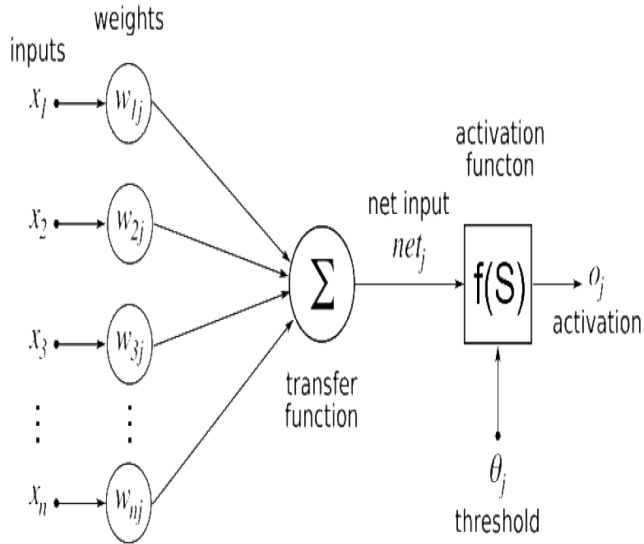


Figure 7: Typical Neural Network process (Shaikh, 2017).

In the algorithm training, two basic operations are performed, the forward and backward pass operations. Weights of the neural network are updated on the basis of the error obtained in the forward pass as shown in Figure 7. These operations are matrix multiplications. For a typical convolution neural network of 16 hidden layers. It has about 140 million parameters which are the weights and bias. Thinking of the number of multiplication applications, it would take typical system years to completely train the model (Shaikh, 2017). Thus, using the GPU can enable the model to be trained at once.

### Electronic Circuit diagram of the system

Figure 8 shows the circuit diagram of the proposed intelligent system. In the circuit, the 15V direct current from the step-down transformer is passed through the bridge rectifier and regulated to 12v by the 7812-voltage regulator, the 12v is used for charging the battery which acts as a power source to the entire system. A transistor is connected across the

12v and 2k resistors connected across to act as a voltage divider. The charge and voltage control are used to enable the raspberry controller to stop charging once the battery is full.

Once the switch is pressed to connect the circuit, 7805 voltage-regulator is used to step the voltage down from 12v to 5v to power the other components (raspberry, camera, buzzer etc.) aside from the pump that taps voltage directly from the battery. The camera supplies real-time images which will be used for decision making by the raspberry pi. Once the weed has sighted the buzzer which is connected to the raspberry via a transistor and a resistor will alert the farmer to stop for spraying. The pump control connected to the raspberry then sends information to the pump which contains permission to spray and the time of spraying based on the size of the bounding box and the Faster R-CNN calculations. The pump module comprises a brushless DC 12V pump, relay, diode to prevent flash back and a transistor to act as a switch to the pump.



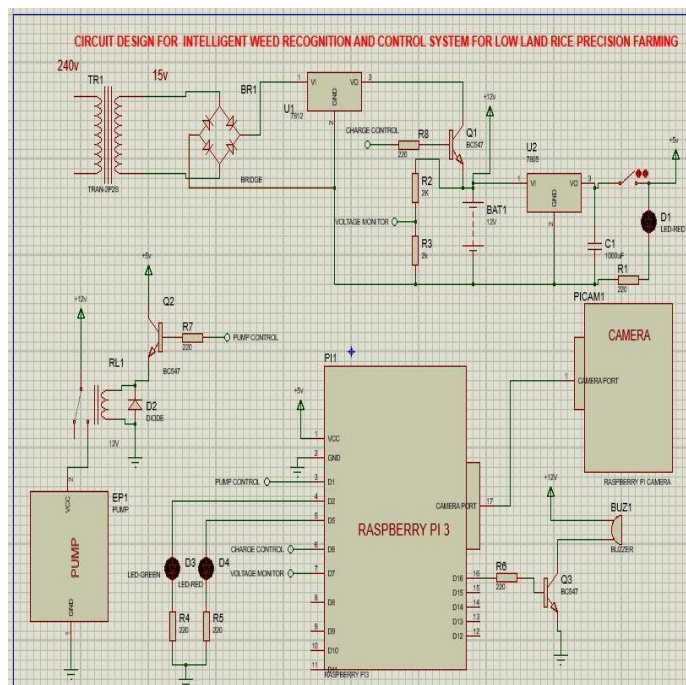


Figure 3.4 Electronic Circuit diagram of the anticipated intelligent system

## CONCLUSION AND RESEARCH DIRECTIONS

In this paper, a critical study of rice distribution in Nigeria, various weed management techniques in literature has been studied. Similarly, papers have been reviewed on computer vision, precision farming. Consequently, weed data has been acquired and prepared for the training of the intelligent computer vision system for rice weed control. The effort is in progress to train acquired weed dataset image on paper space with Google Tensor Flow library using the faster region for convolution neural network, using python3 programming language and opencv2. The trained algorithm and corresponding programming code will be deployed in the raspberry terminal. After the recognition has been achieved with the picamera. The pump will be programmed with raspberry pi to give spraying with the recognized weed. Rigorous qualitative pilot testing shall be carried out at the Teaching and Research Field, FUT, Minna to determine the effectiveness of the anticipated computer vision system to address salient weed infestation rice production to enhance its yield. At this stage, the research is open to criticisms and recommendations.

## REFERENCES

- AgroNigeria. (2014a). Rice Farming: What you need to know. Retrieved May 29, 2018, from <http://agronigeria.com.ng/rice-farming-what-you-need-to-know/>
- AgroNigeria. (2014b). Weed Control : All You Need to Know About Using Simazine. Retrieved May 30, 2018, from <https://agronigeria.com.ng/weed-control-need-know-using-simazine/>
- Ajala, A. S., & Gana, A. (2015). Analysis of Challenges Facing Rice Processing in Nigeria. *Journal of Food Processing, 2015*.
- Akobundu, I. O., Ekeleme, F., Agyakwa, C. W., & Ogazie, C. A. (2016). *West African Weeds*. Ikeja: AfKAR Printing and Publishing Company Limited, Plot 151, Acme Road, Ogba, Ikeja, Nigeria.
- Amin, M. S. M., Rowshon, M. K., & Aimrun, W. (2011). Paddy water management for precision farming of rice. In *Current Issues of Water Management*. InTech.
- Bossu, J., Gée, C., & Truchetet, F. (2007). *Development of a machine vision system for a real-time precision sprayer*. Paper presented at the Eighth International Conference on Quality Control by Artificial Vision.

- Celen, I., Kilic, E., & Durgut, M. (2008). Development of an automatic weed control system for sunflower. *Applied engineering in agriculture*, 24(1), 23-27.
- Christensen, R. G. S. (2006). Site-specific weed management *Handbook of Precision Agriculture* (pp. 215-236): CRC Press.
- Felton, W. (1995). *Commercial progress in spot spraying weeds*. Paper presented at the BRIGHTON CROP PROTECTION CONFERENCE WEEDS.
- Felton, W., & McCloy, K. (1992). Spot spraying. *Agricultural Engineering*, 73(6), 9-12.
- Feyaerts, F., & Van Gool, L. (2001). Multi-spectral vision system for weed detection. *Pattern Recognition Letters*, 22(6-7), 667-674.
- Gerhards, R., & Oebel, H. (2006). Practical experiences with a system for site-specific weed control in arable crops using real-time image analysis and GPS-controlled patch spraying. *Weed Research*, 46(3), 185-193.
- Griepentrog, H.-W., Nørremark, M., & Nielsen, J. (2006). *Autonomous intra-row rotor weeding based on GPS*. Paper presented at the Proceedings of the CIGR World Congress Agricultural Engineering for a Better World, Bonn, Germany.
- Hansson, D., & Ascard, J. (2002). Influence of developmental stage and time of assessment on hot water weed control. *Weed Research*, 42(4), 307-316.
- IRRI. Steps to successful rice. Rice Production Manual, Los Baños (Philippines): International Rice Research Institute (IRRI) Retrieved May 29, 2018, from [www.knowledgebank.irri.org](http://www.knowledgebank.irri.org)
- IRRI. Herbicides. Retrieved June 6, 2018, from <http://www.knowledgebank.irri.org/step-by-step-production/growth/weed-management/herbicides>.
- Jenny. (2018). Paperspace: Overview. Retrieved from <https://paperspace.zendesk.com/hc/en-us/articles/2160323-paptgerspace-overview>
- Longtau, S. R. (2003). Multi-agency partnerships in West African Agriculture. *A Review and Description of Rice Production System in Nigeria. Ecosystem Development Organization (EDO). Report*.
- M.S.M. Amin, M. K. R. a. W. A. (2011). *Paddy Water Management for Precision Farming of Rice*: InTech.
- Maclean, J., Hardy, B., & Hettel, G. (2013). *Rice Almanac: Source book for one of the most important economic activities on earth*: IRRI.
- Nwilene, F., Oikeh, S., Agunbiade, T., Oladimeji, O., Ajayi, O., Sié, M., . . . Touré, A. (2008). Growing lowland rice: a production handbook. *Africa Rice Center (WARDA)* Retrieved from [http://www.fao.org/fileadmin/user\\_upload/ivc/docs/Growin%20lowland%20rice\\_%20production%20handbook\\_prepress%20final%20version\\_19-05-08\\_low%20res.pdf](http://www.fao.org/fileadmin/user_upload/ivc/docs/Growin%20lowland%20rice_%20production%20handbook_prepress%20final%20version_19-05-08_low%20res.pdf).
- Odero, D., & Rainbolt, C. (2011). Weed management in rice. *Agronomy Department, Florida Cooperative Extension Service, Institute of Food and Agricultural Sciences, University of Florida: Gainesville, FL, USA*.
- Olaleye, A. O., & Ogunkunle, A. (2009). Morphology, Organic Carbon and Dissolved Nutrients in Groundwater Table in Two Benchmark Wetlands Sites in Nigeria, (March).
- Omega (Producer). (2018, March 08). How does a Fuzzy Logic Controller work? Retrieved from <https://www.omega.co.uk/technical-learning/pid-fuzzy-logic-adaptive-control.html>
- Pusphavalli, M., & Chandraleka, R. (2016). Automatic Weed Removal System using Machine Vision. *International Journal of Advanced Research in Electronics and Communication Engineering (IJARECE)*, 5(3), 503-506.
- Rafael C. Gonzalez, R. E. W. (2002). *Digital Image Processing*. prentice hall upper saddle river, new jersey 07458: Tom Robbins.
- Ribeiro, A., Fernández-Quintanilla, C., Barroso, J., García-Alegre, M., & Stafford, J. (2005). Development of an image analysis system for estimation of weed pressure. *Precision agriculture*, 5, 169-174.
- Rodenburg, J., & Johnson, D. E. (2009). Chapter 4 - Weed Management in Rice-Based Cropping Systems in Africa. In D. L. Sparks (Ed.), *Advances in Agronomy* (Vol. 103, pp. 149-218): Academic Press.
- Rodenburg, J., Meinke, H., & Johnson, D. E. (2011). Challenges for weed management in African rice systems in a changing climate. *The Journal of Agricultural Science*, 149(4), 427-435.
- Shaikh, F. (2017). Why are GPUs necessary for training Deep Learning models? Retrieved February 8,
- Statista. (2017). Rice - Statistics & Facts | Statista. Retrieved June 4, 2018, from <https://www.statista.com/topics/1443/rice/>

Technopedia (Producer). (2018, March 08). Artificial Neural Network(ANN). *Technopedia Inc.* Retrieved from <https://www.technopedia.com/definition/5967/artificial-neural-network-ann>

Tellaache, A., Burgos-Artizzu, X. P., Pajares, G., & Ribeiro, A. (2008). A vision-based method for weeds identification through the Bayesian decision theory. *Pattern Recognition*, 41(2), 521-530.

Tian L., S. D. C., Norris R.F. (2000). Machine vision identification of tomato seedlings for automated weed control.

<http://citeseerx.ist.psu.edu/viewdoc/download?doi=10.1.1.42.6500&rep=rep1&type=pdf>  
Warda, N. Y. (2015). *Doing good business with quality irrigated dry season lowland rice*. Nigeria: Deutsche Gesellschaft für Internationale Zusammenarbeit (GIZ) GmbH

Yang C.C., P. S. O., Landry J.A., Ramaswamy H.S. And Ditommaso A. ( 2000). Application of artificial neural networks in image recognition and classification of crop and weeds. *Canadian Agricultural Engineering*, 42(3).





## ARIMA MODELLING OF COCOA PRODUCTION IN NIGERIA: 1900-2025

Joshua Olusegun Ajetomobi<sup>1\*</sup> and Adesola Olutayo Olaleye<sup>2</sup>

Department of Agricultural Economics and Management, University of Swaziland, Swaziland 2

Department of Agronomy, University of Swaziland, Swaziland \*

Corresponding Author: joajetomobi@uniswa.sz

### Abstract

*A major target crop in Nigeria's export diversification strategies is cocoa. Over the last century, the production has experienced significant rise and fall in the face of diverse institutional and climate changes. Using production data which varies from 1900 to 2017, this study attempts to forecast Nigerian cocoa production between 2018 and 2025 using Auto-regressive Integrated Moving Average (ARIMA) model. The automated analytical procedure implemented in R shows that ARIMA (1, 1, 0) is the combination with the least AIC and BIC and hence, the most appropriate for the forecast. The results reveal that cocoa production is projected to fall by more than 20% in 2025 when compared to 2017 figure.*

Keywords: Forecast, Cocoa Production, ARIMA, Nigeria

JEL Code: P24, P44, C53. **Introduction**

Cocoa is a major agricultural commodity that has gained the interest of many consumers across the world due to increased demand for chocolate. Currently, about 90% of global cocoa beans produced are utilized for production of chocolate based products such as chocolate bars, cocoa beverages, cocoa powder and cake (Beg et al., 2017; Malhotra and Apshara, 2017). The supply side of cocoa market over the past three decades has been dominated by African countries, notably, Cote d'Ivoire, Ghana, Cameroon and Nigeria. Other major players in the supply side are Brazil and Indonesia (Anga, 2014). The crop is a major source of income for small scale farmers in those

countries. About 70% of the world supply is produced in Africa and the crop provides livelihood for between 40 and 50 million people in the region (Nkamleu, Nyemeck, & Gockowski, 2010). A summary of the annual production in Nigeria and other West African countries between 1984/85 cropping seasons to 2013/2014 is as shown in Fig 1 (Wessel et al., 2015; Vanhove, Vanhoudt and Van Damme, 2016). The rise in production across the countries has been attributed to increase in the land area allocated to cocoa production as it has been observed that the average yields have been declining as a result of changes in climate as well as increasing age of the cocoa trees (Vanhove, Vanhoudt and Van Damme, 2016).

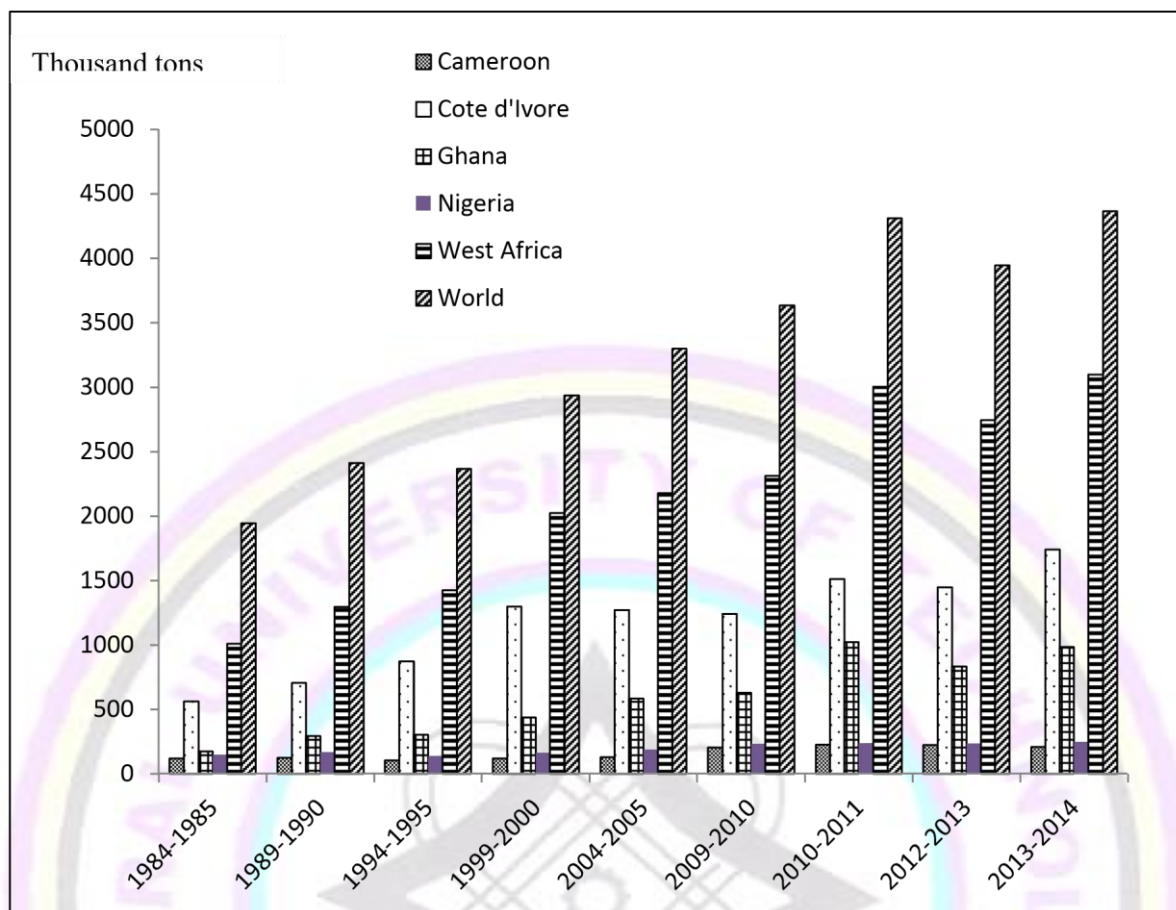


Fig 1: Cocoa Production in West Africa and world

Source: (Wessel and Quist-Wessel, 2015)

Given recent high volatility in the prices of crude oil, the federal government of Nigeria is currently making frantic efforts to revive the agricultural sector so as to make it a principal generator of foreign exchange to support and facilitate economic development. A major target crop in the nation's export diversification strategies is cocoa. The historical development of the crop in Nigeria is summarized in Table 1. The crop was introduced into the country in 1870 and within two decades, the production had spread across major cities in the southern and eastern part of the country. The boom in cocoa trade led to establishment of several institutions and processing plant between 1940 and 1970. These include Cocoa Marketing Board (CMB) in 1947, Cocoa Research Institute of Nigeria in 1964, and Cocoa Industries Limited in 1967. Due to disincentive effects of CMB, the board was abolished in 1986 leaving the crop export and pricing strategies in the hand of private entrepreneurs who now interface between cocoa

farmers and importers of the commodity. In order to ensure quality control and speedy revival of Nigerian cocoa sector, the federal government set up the National Cocoa Development Committee in 1999. The committee set a short-term production target of 320,000 tonnes per annum and a long-term target of 600,000 tonnes. At present, none of this target has been achieved.

A long list of challenges responsible for slow pace of the cocoa revival is evident from previous studies. These include pests and diseases, soil fertility, limited access to finance, ageing of cocoa trees and farmers, fertilizer politics, recent dwindling demand for chocolate, inconsistency and/or discontinuity of various government policies due to political instability, power outage, collapse of cocoa processing firms in the country and child labour (Binuomote & Ajetomobi, 2012; Fold, 2001; Samuel, 2017, Asare et al., 2017). At the international Cocoa Summit held in Abuja in

2017, the federal government of Nigeria highlighted few reforms to re-position the cocoa sector (Export Digest, 2017). These include implementation of the ease of doing business reform, provision of incentives for youth that are interested in cocoa farming, and re-launching of cocoa production in South-western Nigeria.

Table 1: Timeline History of Cocoa Development in Nigeria

Year	Development	Remark
1870	Establishment of the first cocoa farm in Bonny and Calabar	The area was not the best suitable place for cocoa cultivation
1880	Establishment of cocoa farm in Lagos and its immediate environment	The area was found to be suitable for cocoa propagation
1890	Planting of cocoa spread from Lagos to other parts of South Western region	Ondo state in the southwestern region is currently the highest producer of the crop
1886	Cocoa beans was exported from Nigeria for the first time	25 cwt was exported
1887	Government Botanical Garden was established in Ebute Metta, Lagos	The organization started cocoa seed distribution in 1893
1947	Establishment of Cocoa Marketing Board	
1964	Cocoa Research Institute of Nigeria (CRIN) was established	The basic aim of CRIN is to carry out research in cocoa, kola, and coffee and provide a platform and quality facilities for teaching and research with these agricultural commodities
1967	The first cocoa processing firm (Cocoa Industries Limited, Ikeja Lagos) was established	It is now moribund but discussions are on-going for its rejuvenation
1985	Cocoa Marketing Board was abolished	Cocoa market became liberalized
1986	Cocoa Association of Nigeria was established	Since abolition of marketing board, the organization has been the private sector representative of Nigeria in all international organizations involved in cocoa,



1999	National Cocoa Development Committee established	(NCDC) was	NCDC is made up of 14 cocoa producing states in Nigeria
------	--	------------	---

Given the important position of cocoa as a cash crop and the attention it currently commands in the economic diversification strategies of Nigerian government, it is worthwhile to provide some insight into the production of the crop in the nearest future. With availability of more than a century past production figures (1900 – 2017), the main objective of this study is to use the historical production figures to forecast cocoa production up to 2025 using Auto-regressive Integrated Moving Average (ARIMA) model.

### Methodology

#### The ARIMA Model

ARIMA is a model developed by Box and Jenkins in 1970. The rationale behind the model is to identify, estimate and diagnose a time series model where time is the main explanatory variable (McCleary, Hay, Meidinger, & McDowall, 1980). Most of the time, the use of the model is limited to forecasting long time series of high frequency (Kostić, Lepojević, & Janković-Milić, 2016). Annual data on cocoa production between 1900 and 2017 is used for the analysis in this study. Therefore, non-seasonal ARIMA model is employed. ARIMA is usually specified by three order parameter,  $p, d, q$ . The autoregressive component of the model refers to the use of past values to predict the observed values. The autoregressive parameter,  $p$ , refers to the number of lags allowed in the model. For example ARIMA( $n, 0, 0$ ) is represented by

$$Y_t = \mu + \phi_1 Y_{t-1} + \phi_2 Y_{t-2} + \dots + \phi_p Y_{t-p} + \epsilon_t$$

Where  $\mu$  to  $\phi_p$  are the model parameters

The  $d$  component of the model specification indicates the degree of differencing in the integrated ( $I$ ) component.

The moving average component of the model,  $q$ , represents the error of the model as a function of previous error terms

$$Y_t = \mu + \phi_1 Y_{t-1} + \phi_2 Y_{t-2} + \dots + \phi_p Y_{t-p} + \epsilon_t$$

Autoregressive, differencing and moving average are the three components of a non-seasonal ARIMA model which can be written in linear form as:

$$Y_t = \mu + \phi_1 Y_{t-1} + \phi_2 Y_{t-2} + \dots + \phi_p Y_{t-p} + \epsilon_t$$

Where  $d$  is differenced times and  $\mu$  is the constant term.

The model work best on long stable time series, approximate historical pattern but do not explain the structure of the underlying data mechanism. In this study,  $Y_t$  is cocoa production measured in tonnes from 1900 to 2017. The data were compiled from the archives of Cocoa Research Institute of Nigeria and annual abstracts of statistics from the National Bureau of Statistics. The analysis of the data involves the use of the following R packages: forecast, urca, and ggplot2.

### Results and Discussion

#### Trend Analysis of Cocoa Production

The time series data on cocoa production is plotted in Figure 1 and the density plot is shown in Figure 2. A cubic function of time was included in the production model to take into account some level of fluctuation in the production of cocoa over the analysis period. The coefficient of determination shows that technological progress accounts for more than 80% variation in cocoa production in the country. Some of the innovations include development of F3 Amazon cocoa hybrid which reach maturity between 3 and 4 years, discovery of better soil for cocoa production, development of pest and disease resistant cocoa varieties, and other productivity increasing phenomena.

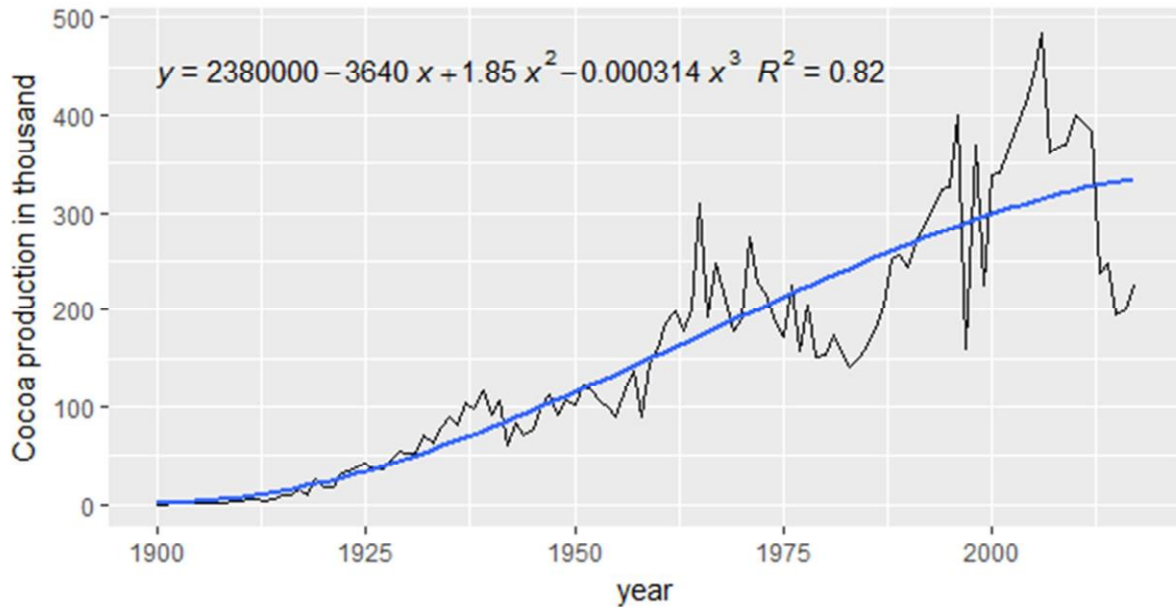


Figure 1: Trend of Cocoa Production: 1900-2017

Figure 1 shows that the trend exhibits a considerable increase from 1900 up to early 1970s. Following abolition of marketing board and liberalization of the commodity market in the 1980s, substantial fluctuation in the production becomes increasingly evident. In 1977, the production dropped to about 160000 tonnes but rose to about 205000 in 1987. The value declined to 160000 in 1997 and increased by more than 100% in the next year. There is a need to address two main methodological issues with Figure 1. One,

there is a need to (i) remove the unequal variances and (ii) address the trend component. The case of unequal variances is addressed by using the logarithmic transformation of the series while the trend component is removed by taking the first difference of the cocoa production series. The evolution of the logarithmic form of the series is shown in Figure 2. The graph indicates that about 90% variation in the log of cocoa production is explained by quadratic trend.

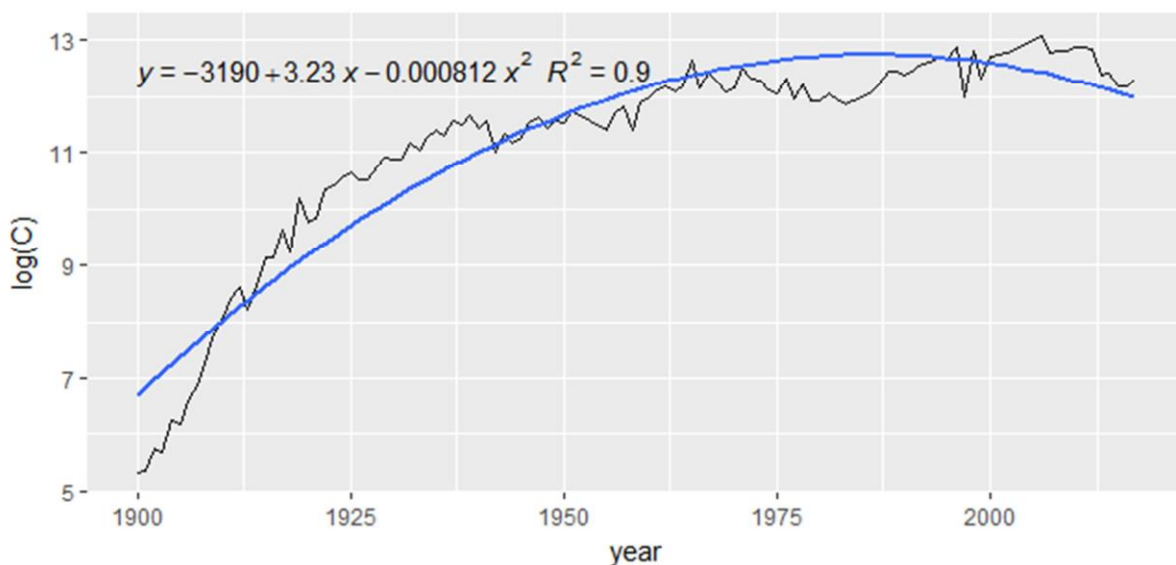


Figure 2: The Trend of the Log of Cocoa Production: 1900 - 2017

#### The ARIMA Model

A basic requirement for fitting an ARIMA model is that the series should be stationary. The stationarity

of the log of cocoa production series was formally tested with Augmented Dickey Fuller (ADF) test

(Dickey & Fuller, 1979). The results are presented in Table 1. The variable is non-stationary at levels. This confirms the visual inspection of Figure 2.

However, the series is stationary after first differencing. This implies that the component of the ARIMA model is 1.

Table 1: Results of Augmented Dickey Fuller Unit Root Test

Series	Model	ADF Lags	ADF $\tau$
Log of cocoa production			
Levels	Trend and intercept	1	-3.7825
First difference	Trend and intercept	1	-9.1547***

\*\*\* Statistically significant at 1% level

Auto-correlation Function (ACF) and Partial Auto-correlation Function for the differenced series are used to determine the orders of the moving average ( ) and auto-regression ( ) components of ARIMA model respectively. The results are shown in Figures 2 and 3. Significant auto-correlation and

partial auto-correlation occur at lags 1 and 2. This suggests that the ARIMA model can be tested with autocorrelation or moving average of order 1 and 2. The optimal , , components of the ARIMA model is determined automatically using auto.arima command in R forecast package.

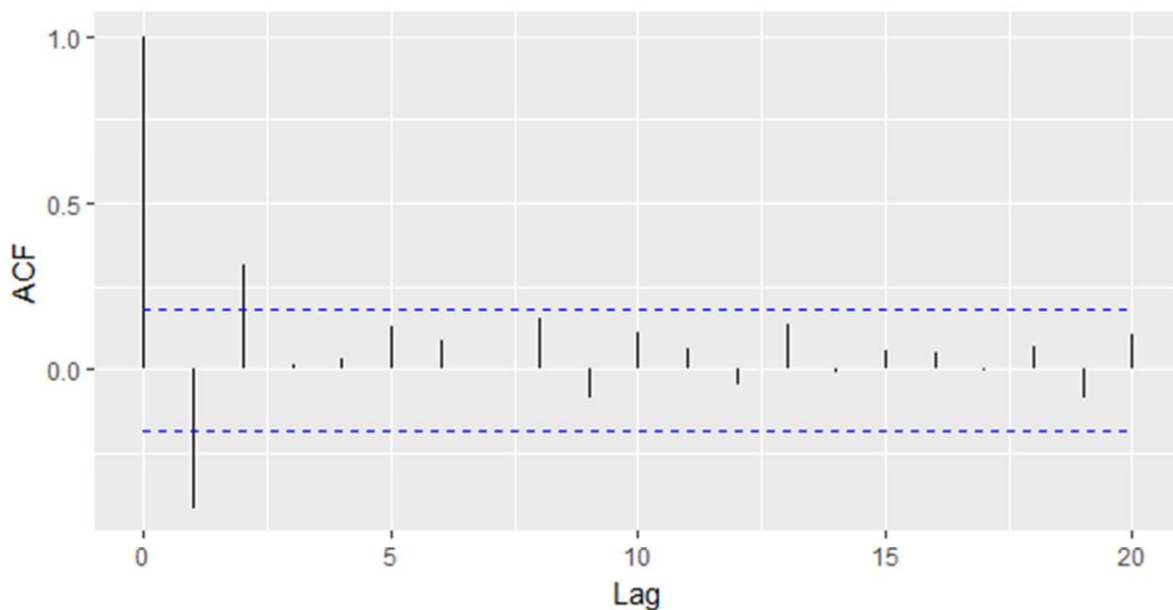


Figure 3: ACF for Log Differenced Cocoa Production Series



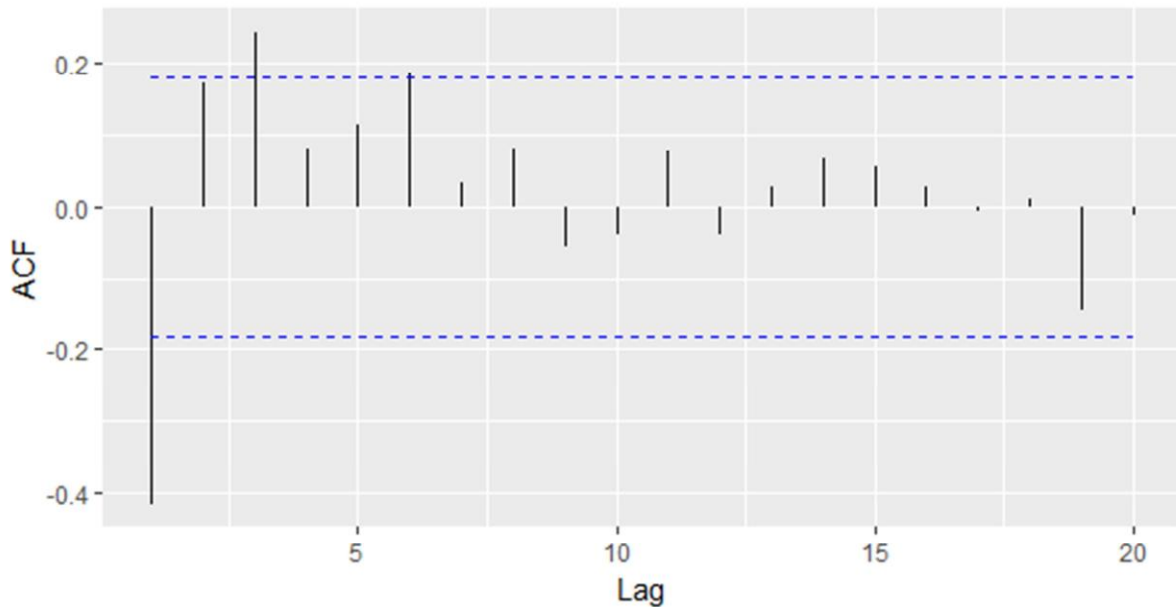


Figure 4: PACF for Log Differenced Cocoa Production Series

The automated procedure shows that the best parameters for the ARIMA model are 1, 2, 1. This agrees with the expectation already derived from visual inspection of the ACF and PACF. The model involves auto-regressive and moving average terms of 1 and 0 while a differencing of order 1 is incorporated in the model. The fitted model is as shown in equation 1.

$$\begin{aligned}
 &0.5704 \quad 0.0752 \quad \text{"\#\$"%\& \text{"\%'\#\#} \\
 &1402.72) * 2809.55 \quad - \quad * \\
 &2814.97
 \end{aligned}$$

The coefficient of the first order auto-regression, -0.5704 implies that the next value in the series is

taken as dampened value by a factor of -0.5704. In order to verify the correctness of the order of parameters and the structure of the model, the ACF and PACF plots of the residual are examined. The results are summarized in Figure 4. The graphs show that there is no significant auto-correlation present. Therefore, it can be concluded that the model is correctly specified. The model is used to forecast cocoa production in thousand tonnes up to 2025. The result is presented in Figure 5 and Table 3. The forecast values (Table 3), clearly indicates that cocoa production in Nigeria may decline to about 74000 tonnes by 2025, *ceteris paribus*. This is lower than the figure recorded in 1945.

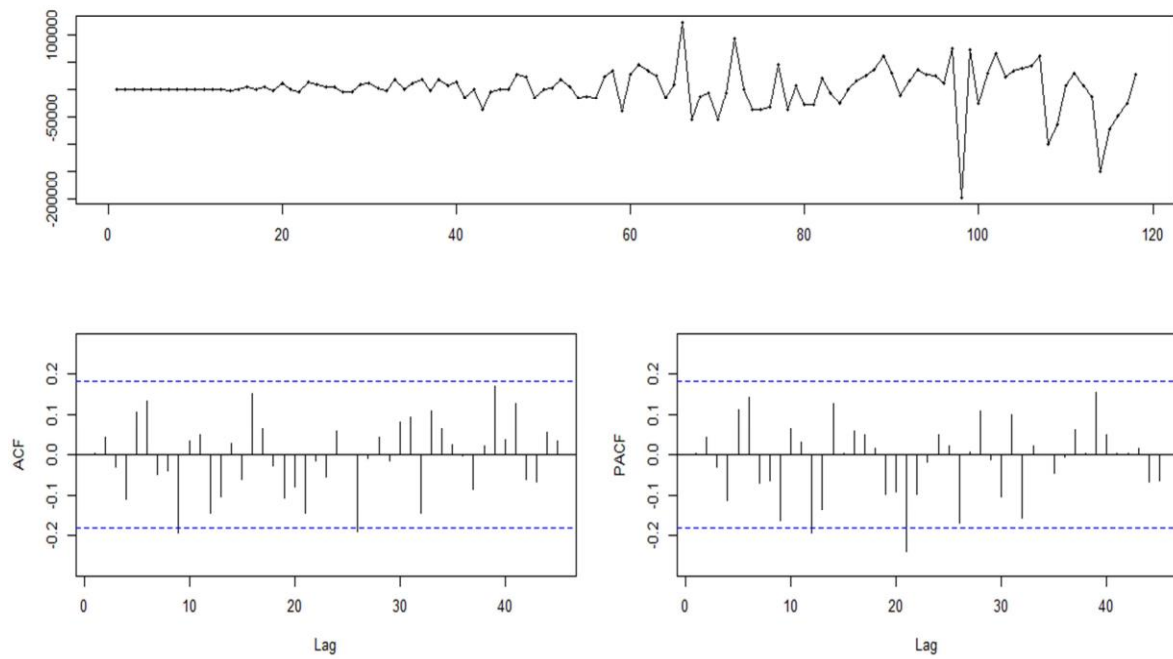
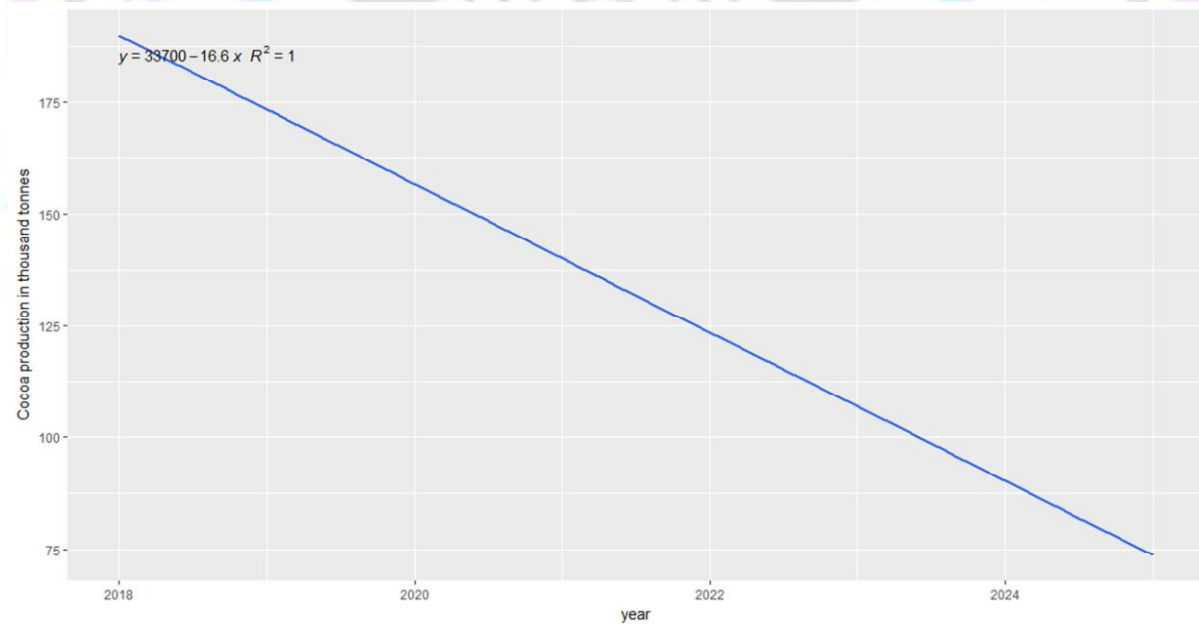
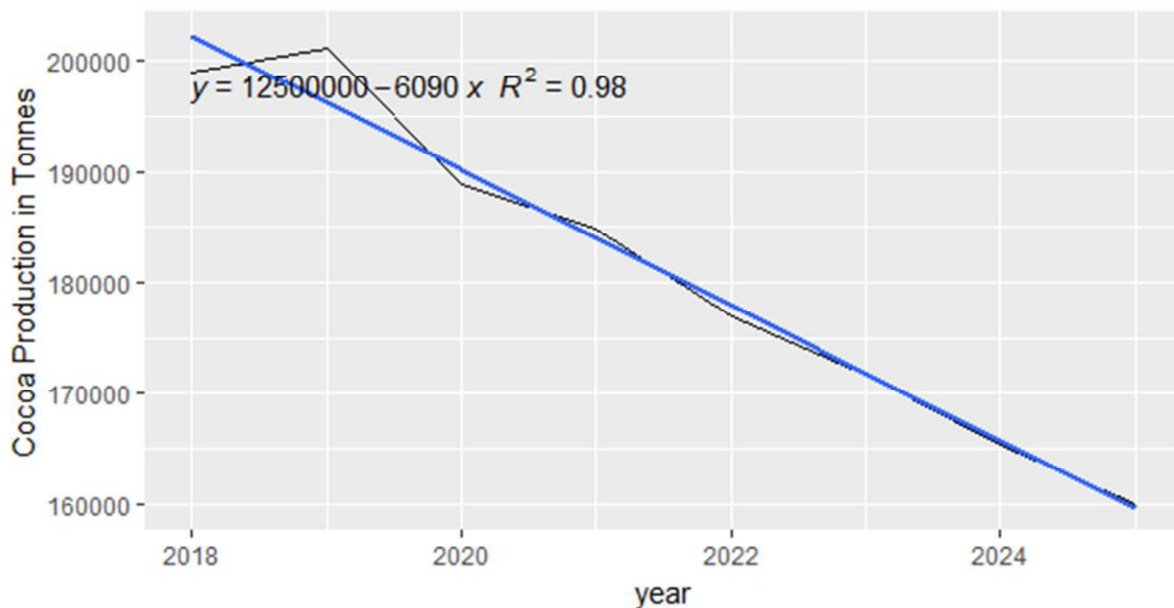


Figure 5: ACF/PACF of Residual



Year	Forecast	Lower 80%	Upper 80%	Lower 95%	Upper 95%
2018	198955.8	147399.2	268545.7	125758.9	314756.3
2019	201123.4	142549	283766.4	118802.2	340487.1

2020	188909.7	121514.6	293683.9	96202.84	370954.5
2021	184910	111300.9	307200.8	85073.31	401909
2022	177012.3	98219.33	319014.3	71908.65	435738.6
2023	171649.4	88389.51	333337.1	62203.51	473663.1
2024	165359.7	78618.76	347803	53038.52	515546.9
2025	159969.8	70276.94	364135.7	45468.35	562816.6



### Conclusion

This study shows that production of cocoa beans has a tendency to decline steadily in the next 8 years in Nigeria. The following recommendations are suggested to avert the trend:

National Cocoa Development Committee should develop feasible agenda to attract unemployed graduates into cocoa industry, particularly in viable producing states

Cocoa Research Institute of Nigeria should work closely with the various agricultural extension services (national and private) in the country to disseminate new cocoa hybrid

Local investors and private participants in cocoa production and those interested in entering into the business should be incentivised by government through provision of adequate access to credit at reasonable interest rate and reducing the bottlenecks involved in land acquisition and/or cocoa contract farming and

Cocoa Association of Nigeria should ensure that their members supply high quality cocoa to the market.

Anga, J.-M. (2014). The world cocoa economy: Current status, challenges and prospects. *Development*, 9, 10.

Asare, R. et al. (2017) 'Influences of shading and fertilization on on-farm yields of cocoa in Ghana', *Experimental Agriculture*, 53(3), pp. 416–431.

Beg, M. S. et al. (2017) 'Status, supply chain and processing of cocoa - A review', *Trends in Food Science & Technology*, 66(Complete), pp. 108–116. doi: 10.1016/j.tifs.2017.06.007.

Binuomote, S. O., & Ajetomobi, J. O. (2012). The effects of structural breaks on cocoa yield response in Nigeria (1961–2007). *International Journal of Applied Agriculture and Apiculture Research*, 8(1), 46–58.



- Dickey, D. A., & Fuller, W. A. (1979). Distribution of the estimators for autoregressive time series with a unit root. *Journal of the American Statistical Association*, 74(366a), 427–431.
- Fold, N. (2001). Restructuring of the European chocolate industry and its impact on cocoa production in West Africa. *Journal of Economic Geography*, 1(4), 405–420.
- Kostić, Z., Lepojević, V., & Janković-Milić, V. (2016). Modeling monthly inflation in the Republic of Serbia, measured by consumer price index. *Facta Universitatis, Series: Economics and Organization*, 145–159.
- Malhotra, S. K. and Apshara, S. E. (2017) ‘Genetic resources of cocoa (*Theobroma cacao* L.) and their utilization-An Appraisal’, *Indian Journal of Genetics and Plant Breeding (The)*, 77(2), pp. 199–213.
- McCleary, R., Hay, R. A., Meindinger, E. E., & McDowall, D. (1980). *Applied time series analysis for the social sciences*. Sage Publications Beverly Hills, CA.
- Nkamleu, G. B., Nyemeck, J., & Gockowski, J. (2010). *Technology gap and efficiency in cocoa production in West and Central Africa: Implications for cocoa sector development*. African development bank.
- Samuel, A. O. (2017). Problems and Prospects of Cocoa Production in Nigeria Economy: A Review. *International Journal of Social Sciences*, 11(2).
- Vanhove, W., Vanhoudt, N. and Van Damme, P. (2016) ‘Effect of shade tree planting and soil management on rehabilitation success of a 22-year-old degraded cocoa (*Theobroma cacao* L.) plantation’, *Agriculture, Ecosystems & Environment*, 219, pp. 14–25.
- Wessel, M. and Quist-Wessel, P. F. (2015) ‘Cocoa production in West Africa, a review and analysis of recent developments’, *NJAS-Wageningen Journal of Life Sciences*, 74, pp. 1–7.

## SEED YIELD AND PHYSIOLOGICAL SEED QUALITY OF COWPEA VARIETIES SOWN AT DIFFERENT PLANTING DATES IN MINNA, SOUTHERN GUINEA SAVANNA OF NIGERIA.

O. A. Adediran<sup>1\*</sup>, H. Ibrahim<sup>1</sup>, J. A. Oladiran<sup>1</sup>, U. Yakubu<sup>1</sup> and O. A. Adesina<sup>1</sup>

<sup>1</sup> Department of Crop Production, Federal University of Technology, Minna, Nigeria.

\*Corresponding author's Email- [o.adediran@futminna.edu.ng](mailto:o.adediran@futminna.edu.ng) GSM: - 234 7030596623

### ABSTRACT

*Cowpea is the most important grain legume in Nigeria but its yield has remained low. Inappropriate sowing date as well as use of poor quality seeds by farmers have been identified as part of the factors responsible for the low yields obtained on farmers' fields. A field and laboratory study was conducted to determine the yield and quality of seeds harvested from cowpea varieties planted at different dates within the growing season of 2017. The study was a two factor experiment consisting of nine planting dates (planting at 2 weekly intervals from 19<sup>th</sup> May to 8<sup>th</sup> September, 2017) and three cowpea varieties (IT93K-452-1, Oloyin and Kanannado). Data were collected on seed yield, 100-seed weight, germination percentage, germination speed, seedling weight and seedling vigour index. Data collected were subjected to analysis of variance and the treatments means were separated using least significant difference at 5% level of probability. Results revealed that Oloyin variety had the highest seed yield when sown on 19<sup>th</sup> May. The value was however at par with the seed yield of plants sown on 11<sup>th</sup> August. Kannanado variety had the highest seed yield when sown on 28<sup>th</sup> July which was equally at par with the yield obtained when sown on 11<sup>th</sup> August. IT93K-452-1 equally had the highest seed yield when sown on 19<sup>th</sup> May which was similar to value obtained in plants sown on 1<sup>st</sup> July followed by the seed yield obtained in plants sown on 14<sup>th</sup> June and 11<sup>th</sup> August which had similar values. Seeds obtained from plants sown on 11<sup>th</sup> and 25<sup>th</sup> of August had significantly higher germination percentage, germination speed, seedling weight and seedling vigour index before and during storage than the seeds sown earlier or later in the three varieties. Among the varieties, Kanannado produced the heaviest seeds followed by Oloyin but IT93K-452-1 had the highest seed yield followed by Oloyin and the least seed yield was recorded in Kanannado variety. Though Kanannado variety had significantly higher germination percentage and seedling weight at early storage, IT93K-452-1 had significantly higher germination speed, seedling vigour index and stored better. Oloyin variety had the least values of all the quality indices measured. Therefore, for maximum seed yield and quality, planting around 11<sup>th</sup> of August is recommended for farmers in the study area and among the varieties tested, IT93K-452-1 is recommended for higher seed yield and quality.*

**KEYWORDS:** planting date, cowpea varieties, seed yield, germination percentage, seedling vigour,

### INTRODUCTION

Cowpea (*Vigna unguiculata* L. Walp) is the most economically important grain legume in Nigeria. Its seeds are consumed as the major source of protein in most homes in Nigeria. It is a major staple food crop in sub-Saharan African, especially in the savanna regions of West Africa (Dudge *et al.*, 2009). Despite the importance of this crop, the yield obtained on farmers' fields is very low with an average of 450 kg ha<sup>-1</sup> (Omosho, 2014). This yield value is very low compared to the potential yield of 2-3 t ha<sup>-1</sup> recorded in South Africa (Pule-Meulenber *et al.*, 2010). Use of poor quality seeds by farmers is one of the factors responsible for the low grain yield obtained on farmers' fields. Seed is the most crucial input for agricultural production. The response of other input

in agricultural production depends on the quality of the seeds used. Seed quality is an important factor for increasing yield. It is estimated that good quality seeds can contribute about 20-25% increase in yield. Viability and physiological vigour are the two most important factors required for high seed quality (Odindo, 2007). Seed vigour has been known as a comprehensive characteristic affected by many factors, such as the genetics of the seeds, environmental factors during seed development and storage (Sun *et al.*, 2007). The environmental conditions prevalent during seed formation affect the quality of the resultant seeds. This could be aggravated when crops are planted at the wrong time. Water is one of the most important climatic factors for crop production. Both its shortage and excess affect the growth and development of plants directly, and consequently its yield and quality. Plant water

stress resulting from agronomic drought (lack of sufficient water to meet the demand of the crop) has been reported by many workers to affect seed yield and quality by reducing seed size, seed number and shortening the grain filling period (De-Souza *et al.*, 1997). Smith and Zou (2016) reported that abiotic stresses, such as heat, cold, and drought, commonly affect floral organ development and fertility. The authors further reported that sterility is induced by abiotic stresses mostly in male floral organ development, particularly during meiosis, tapetum development, anthesis, dehiscence, and fertilization leading to reduced yield and quality of crops. Given the current scourges that threaten the world (food insecurity and water scarcity); many researchers urge to maximize crop yields with minimum possible water consumption. This involves several practices, including the selection of planting time that matches the crop species throughout the entire growing season (Elsnesr *et al.* 2013). Seed producers must often compromise between maximum seed yield and quality when selecting a planting date. Small holder farmers in Nigeria hardly buy seeds. They use seeds obtained from previous harvests. This small holder farmers account for the production of over 90% of the food consumed in Nigeria. There is therefore the need to inform farmers on the appropriate time to plant cowpea to obtain maximum seed yield of high quality. This study therefore aimed to determine the effect of planting date on the seed yield and quality on three cowpea varieties.

## METHODOLOGY

The field trial was conducted on a farmer's field in Minna, Southern Guinea savanna of Nigeria with the geographical positioning system value of N 09°31.203 and E 06°27.678. It was a factorial combination of three cowpea varieties viz: Kanannado (late maturing), Oloyin (medium maturing) and IT93K-452-1 (early maturing), and nine planting dates (planting at two weeks interval) viz: 19<sup>th</sup> May, 2<sup>nd</sup> June, 16<sup>th</sup> June, 1<sup>st</sup> July, 14<sup>th</sup> July, 28<sup>th</sup> July, 11<sup>th</sup> August, 25<sup>th</sup> August, and 8<sup>th</sup> September. These were arranged in a randomized complete block design. Plants received 20 kg P and 20 kg K ha<sup>-1</sup> at planting using single super phosphate and muriate of potash as source. There were four ridges per treatment plots and yield data were obtained from the 2 inner ridges. Intra and inter-row spacing of 20 x 75 cm was maintained except for Kanannado variety in which 30 x 75cm was maintained because it was a prostrate variety. At mass maturity (end of seed filling period), the seeds were harvested and the quality of the seeds were

tested in the Department of Crop Production, Federal University of Technology Laboratory. Four replicates of hundred seeds were counted for each treatment and weighed on a Mettler balance to determine the 100-seed weight and means were recorded. The seeds were stored in the incubator in open plastic plates at 42<sup>o</sup>C and 81% relative humidity for 8 weeks to accelerate the ageing. The physiological quality indices tested were the following:

**Germination percentage (GP):** Three replicates of 25 seeds from each treatment combination were counted and placed in paper towels moistened with distilled water. The paper towels were placed inside the germination chamber at 30<sup>o</sup>C. A seed was considered to have germinated when radicles significantly emerge. Germinated seeds were recorded every day for 7 days. Germination percentage was calculated according to the formula:

$$GP = \frac{\text{Number of normal seedlings}}{\text{Total seeds tested}}$$

**Speed of germination** was determined using the formula:

$$\frac{\text{Number of germinated seeds at first count} + \text{Number of germinated seeds at final count}}{\text{Days of first count} \quad \quad \quad \text{Days of final count}}$$

**Seedling weight:** At 7 days, the fresh weight of the normal seedlings were determined on a Mettler balance after which they were oven dried at 70<sup>o</sup>C for 48 hours to obtain the dry weight. The value was divided by the number of seedlings to obtain the seedling weight per plant

**Seedling vigour index(SVI):** Ten normal seedlings were randomly selected from each replicate and the plumule length measured. Seedling vigour index were calculated using the formula:

$$SVI = \frac{\text{Seedling plumule length} \times \text{germination\%}}{100}$$

(Akintobi *et al.*, 2017)

Data collected on all parameters were subjected to analysis of variance using statistical analysis system (SAS) and means were separated using least significant difference (LSD) at P=0.05. Data in percentages were transformed to arcsin values before statistical analysis. Where the interaction between planting date and variety was significant throughout the storage period, the table of interaction showing the performance before storage and late storage were presented.



## RESULTS

Table 1 shows the 100-seed weight of the cowpea varieties sown at different planting date. Seeds harvested from Oloyin plants sown on August 11<sup>th</sup> and 25<sup>th</sup> were significantly heavier (24.72 and 24.01 g respectively) than the seeds obtained from plants of the same variety sown on other dates (20.94 – 22.13 g). Kanannado plants produced the heaviest seeds when sown on 1<sup>st</sup> July (28.59 g). The weight was however similar to the values obtained in plants sown on 19<sup>th</sup> May, 16<sup>th</sup> June and 14<sup>th</sup> July. The lightest Kanannado seeds were obtained in plants sown on 8<sup>th</sup> September (25.27 g). In IT93K-452-1 variety, plants sown on 19<sup>th</sup> May had the heaviest seeds (22.18 g) and the value was at par with the seeds obtained in plants sown on 1<sup>st</sup> July (21.18 g). Generally, Kanannado seeds were the heaviest (25.27 - 28.59 g) followed by Oloyin (21.27 – 24.72 g) and IT93K-452-1 had the lightest seeds (19.27 - 22.18g).

Kannanado variety sown on 28<sup>th</sup> July had the highest seed yield (997.99 kg ha<sup>-1</sup>). The value was at par with the seed yield of plants sown on 11<sup>th</sup> August (637.34 kg ha<sup>-1</sup>) (Table 2). The least seed yield in Kanannado variety was obtained in plants sown on 14<sup>th</sup> July (114.94 kg ha<sup>-1</sup>) which was at par with the seed yield of plants sown on 19<sup>th</sup> May, 1<sup>st</sup> July, 25<sup>th</sup> August and 8<sup>th</sup> September. Oloyin variety sown on 19<sup>th</sup> May had the highest seed yield (1506.11 kg ha<sup>-1</sup>) and the value was at par with the seed yield obtained in plants sown on 1<sup>st</sup> July, 14<sup>th</sup> July, 11<sup>th</sup> August and 16<sup>th</sup> June, (1447.23, 1155.44, 1066.35 and 1042.09 kg/ha respectively). The least seed yield in Oloyin variety was obtained in plants sown on 8<sup>th</sup> September (365.15 kg ha<sup>-1</sup>) which was at par with the value obtained in plants sown on 25<sup>th</sup> August (429.67 kg ha<sup>-1</sup>). In IT93K-452-1 variety, plants sown on 19<sup>th</sup> May had the highest seed yield (2013.50 kg ha<sup>-1</sup>) which was at par with the value obtained in plants sown on 1<sup>st</sup> July (1927.11 kg ha<sup>-1</sup>). The least seed yield in IT93K-452-1 variety was obtained in plants sown on 25<sup>th</sup> August and 8<sup>th</sup> September (486.79 and 570.82 kg ha<sup>-1</sup> respectively).

Seeds obtained from plants that were sown in August (11<sup>th</sup> and 25<sup>th</sup>) generally germinated significantly higher both before and during storage than seeds obtained from plants sown earlier (Table 3). The value obtained was however at par with the value recorded in seeds harvested from plants that were sown on 8<sup>th</sup> September during the first four weeks of storage. After 4 weeks in storage (WIS), there was a significant decline in the germination percentage of seeds obtained from plants sown on 8<sup>th</sup> September.

Seeds harvested from plants sown on 19<sup>th</sup> May were the least viable both before and during storage.

Table 4 shows the interaction between planting date and variety on the germination percentage at 0 and 8 weeks in storage. In Oloyin variety, germination percentage before storage (0 WIS) increased as planting date advances with the highest GP recorded in plants sown as from 11<sup>th</sup> August (98-100%). At late storage (8 WIS) however, seeds harvested from Oloyin plants that were sown between 19<sup>th</sup> May and 28<sup>th</sup> July had lost their viability (0% germination). The highest germination percentage in Oloyin seeds at 8 WIS was obtained in seeds harvested from plants sown on 25<sup>th</sup> August (22.68%) which was at par with the value recorded in seeds obtained from plants sown on 11<sup>th</sup> August (16.00%). In Kanannado variety, there was no significant difference between the germination percentage of seeds harvested from plants sown at different sowing dates and the GP ranged between 93 and 100% before storage. At late storage however, seeds obtained from plants sown on 11<sup>th</sup> and 25<sup>th</sup> August had the highest GP (17.33%) and the values were at par with the GP recorded in the other planting dates except seeds harvested from plants sown on 19<sup>th</sup> May, 14<sup>th</sup> July and 9<sup>th</sup> September which had completely lost their viability (Table 4). In IT93K-452-1 variety, seeds harvested from plants sown from 1<sup>st</sup> July up to 8<sup>th</sup> September had significantly higher GP (92-100%) than those sown earlier (69.33 - 89.33%) before storage. In late storage however, seeds harvested from plants sown on 28<sup>th</sup> July stored significantly better (with 33% GP) than those obtained from plants sown earlier and those sown after 11<sup>th</sup> August (9 -20%). Seeds obtained from plants sown on 19<sup>th</sup> May had the least germination percentage in IT93K-452-1 variety (9.33%).

Table 5 shows the seedling weight of three cowpea varieties at different storage period as affected by planting date. At zero storage, the seedlings of plants sown on 1<sup>st</sup> and 14<sup>th</sup> July had significantly higher seedling weight (1.01 and 1.03 g/plant respectively) than those sown earlier or later (0.64 -0.92 g/plant). The least seedling weight was obtained in plants sown on 19<sup>th</sup> May (0.64 g/plant). At 2 weeks in storage, plants sown on 11<sup>th</sup> of August had significantly higher seedling weight (0.89 g/plant) than those planted on other dates (0.53 – 0.74 g/plant) except 28<sup>th</sup> of July. At 4 weeks in storage, plants sown on 11<sup>th</sup> August, 25<sup>th</sup> August, 28<sup>th</sup> July, 1<sup>st</sup> July and 16<sup>th</sup> June had significantly higher seedling weight (0.72 – 0.77 g/plant) than those planted on other planting dates (0.34 – 0.57 g/plant). At 6 and 8 WIS, seeds harvested from plants sown on 11<sup>th</sup> and 25<sup>th</sup>

August had significantly higher seedling weight than those obtained in other planting date. Before and during storage, seeds of plants sown on 19<sup>th</sup> May had the least seedling weight. Generally, Kanannado variety had significantly higher seedling weight than the other two varieties in the first 4 weeks of storage. After 4 WIS however, IT93K-452-1 variety had significantly higher seedling weight than Kanannado. Oloyin consistently recorded the least seedling weight before and during storage.

Table 6 shows the interaction between planting date and variety on seedling weight of cowpea at 0 and 8 WIS. Before storage, seeds obtained from Oloyin plants sown between 1<sup>st</sup> July and 11<sup>th</sup> August had significantly higher seedling weight than other planting dates (0.82 – 0.98 g/plant). The least value was recorded in plants sown on 19<sup>th</sup> May (0.12 g/plant). In Kanannado variety, seeds obtained from plants sown on 14<sup>th</sup> July had significantly higher seedling weight (1.38 g/plant) than other planting dates (0.97 -1.16 g/plant) but the value was at par with what was recorded in plants sown on 1<sup>st</sup> July (1.29 g/plant). In IT93K-452-1 variety, seeds obtained from plants sown between 19<sup>th</sup> May and 11<sup>th</sup> August had similar seedling weight (0.81 -0.96 g/plant) which were significantly higher than the seedling weight obtained in seeds of plants sown on September 8<sup>th</sup> which had the least seedling weight (0.65 g/plant). At late storage however (8 WIS), all the Oloyin seeds irrespective of the planting dates had lost their vigour except those obtained from plants sown on 11<sup>th</sup> and 25<sup>th</sup> August (0.56 and 0.49 g/plant respectively). In Kanannado, seeds obtained from plants sown on 11<sup>th</sup> and 25<sup>th</sup> August had the highest seedling weight (0.52 and 0.48 g/plant respectively) which was at par with the seedling weight of seeds obtained from plants sown on 1<sup>st</sup> and 28<sup>th</sup> July (0.45 and 0.44 g/plant respectively). Seeds obtained from Kanannado plants sown on 19<sup>th</sup> May, 14<sup>th</sup> July and 8<sup>th</sup> September had completely lost their vigour at this storage period. Seeds obtained from IT93K-452-1 plants sown on 11<sup>th</sup> and 25<sup>th</sup> August had the highest seedling weight (0.59 g/plant). The value was at par with the weight obtained in seeds of plants sown on 16<sup>th</sup> June and 1<sup>st</sup> July (0.58 and 0.49 g/plant respectively). The least seedling weight was recorded in seeds of plants sown on 19<sup>th</sup> May (0.29 g/plant). Generally, IT93K-452-1 seeds had significantly higher seedling weight in late storage than the remaining varieties. Though generally in the three varieties, vigour reduced with age but none of the IT93K-452-1 seeds completely lost its vigour in storage irrespective of the planting date unlike the remaining varieties tested.

The speed of germination generally increased as planting date advances up to 25<sup>th</sup> of August after which there was a decline in plants sown on 8<sup>th</sup> September before and during storage (Table 7). Seeds obtained from plants sown on 11<sup>th</sup> and 25<sup>th</sup> August had similar speed of germination which were significantly higher than those obtained from plants sown earlier or later. Kanannado and IT93K-452-1 plants had similar speed of germination which were significantly higher than the speed of germination of Oloyin seeds before storage up till mid storage (4 WIS). At late storage however (6-8 WIS), IT93K-452-1 plants germinated with significantly higher speed than Kanannado. Throughout the storage period, Oloyin variety had the least speed of germination. Generally, the speed of germination reduced as the seeds aged.

The interaction between planting date and variety on speed of germination is shown on Table 8. The speed of germination of Oloyin seeds increased as the planting date of the mother plants advanced with seeds of plants sown from 11<sup>th</sup> August up to 8<sup>th</sup> September having significantly higher speed of germination (25.91 – 27.86) than plants sown earlier (1.32 -16.86). In Kanannado variety, plants sown on 1<sup>st</sup> July had the highest speed of germination (26.57) and the value was at par with the speed recorded in seeds obtained from plants sown on 19<sup>th</sup> May, 2<sup>nd</sup> June and 25<sup>th</sup> August. In IT93K-452-1 seeds however, seeds obtained from plants sown from 16<sup>th</sup> June up to 8<sup>th</sup> September germinated with similar speed (22.95 – 26.91) which were significantly higher than the speed of seeds obtained from plants sown earlier than 16<sup>th</sup> June (12.81 -16.91). At late storage however (8 WIS), the speed of germination of Oloyin seeds harvested from plants sown on 11<sup>th</sup> and 25<sup>th</sup> August were similar (3.24 and 4.48 respectively). Seeds of Oloyin variety harvested from plants sown on other planting dates had lost their viability. Seeds of Kanannado plants sown on 11<sup>th</sup> and 25<sup>th</sup> August had the highest speed of germination (3.95 and 4.62). Seeds obtained from Kanannado plants sown on 19<sup>th</sup> May, 14<sup>th</sup> July and 8<sup>th</sup> September were no longer viable at this storage period. Seeds obtained from IT93K-452-1 plants sown between 28<sup>th</sup> July and 25<sup>th</sup> August had significantly higher speed of germination (7.00 - 8.86) than seeds obtained from plants sown earlier (1.52 – 5.38). Generally, IT93K-452-1 seeds had higher speed of germination in late storage than the remaining varieties.

Before storage, plants sown on 11<sup>th</sup> August had the highest seedling vigour index (21.49) followed by those sown on 25<sup>th</sup> August (15.75) which had similar



values with seeds obtained from plants sown on 14<sup>th</sup> and 28<sup>th</sup> July (Table 9). The least vigour was obtained from seeds obtained from plants sown between 19<sup>th</sup> May and 16<sup>th</sup> June (6.94 – 7.96). At 2 weeks in storage, seeds obtained from plants sown on 11<sup>th</sup> August maintained the highest vigour (20.81) followed by seeds obtained from plants sown on 28<sup>th</sup> July and 25<sup>th</sup> August (15.38 and 14.33 respectively). The least vigour was recorded in plants sown on 8<sup>th</sup> September (8.04). At 4 WIS, seeds obtained from plants sown between 14<sup>th</sup> July and 11<sup>th</sup> August (20.55 -22.39) had similar vigour and were significantly higher than the vigour of the seeds obtained from the other planting dates. The least was obtained in plants sown between 19<sup>th</sup> May and 2<sup>nd</sup> June (7.00 and 5.98 respectively). At 6 and 8 WIS however, seeds obtained from plants sown in August (11<sup>th</sup> and 25<sup>th</sup>) had significantly higher vigour than seeds obtained from plants sown on other dates. Before and throughout the storage period, the order of vigour among the varieties was IT93K-452-1 > Kanannado > Oloyin.

The interaction between planting date and variety on seedling vigour index is presented on Table 10. Before storage, Oloyin seeds obtained from plants sown in August (11<sup>th</sup> and 25<sup>th</sup>) had the highest vigour (20.90 and 18.63 respectively) followed by seeds of plants sown on 14<sup>th</sup> and 28<sup>th</sup> July and 8<sup>th</sup> September which had similar vigour index (12.19 -14.03). The least vigour was obtained in seeds of plants sown on 19<sup>th</sup> May and 2<sup>nd</sup> June (0.00). In Kanannado variety, seeds of plants sown on 11<sup>th</sup> August had the highest vigour index (19.77) followed by the seed of those sown in July (1<sup>st</sup>, 14<sup>th</sup> and 28<sup>th</sup>) and 25<sup>th</sup> August (11.50 – 14.5). The least vigour was recorded in those sown on 19<sup>th</sup> May, 16<sup>th</sup> June and 8<sup>th</sup> September (6.27 – 8.7). In IT93K-452-1 variety, plants sown on 28<sup>th</sup> July and 11<sup>th</sup> August had the highest vigour (20.53 and 23.80 respectively) followed by plants sown on 1<sup>st</sup> and 14<sup>th</sup> July and 25<sup>th</sup> August (16.31, 17.90 and 16.61 respectively). The least was obtained in seeds of plants sown on 16<sup>th</sup> June and 8<sup>th</sup> September (10.04 and 10.92 respectively). At late storage (8 WIS), only Oloyin seeds obtained from plants sown on 11<sup>th</sup> and 25<sup>th</sup> August maintained their vigour (1.62 and 1.94 respectively). Oloyin seeds obtained from plants sown on other planting dates had already lost their vigour at this storage period. Kanannado seeds obtained from plants sown on 19<sup>th</sup> May, 14<sup>th</sup> July and 8<sup>th</sup> September had equally lost their vigour. The highest vigour in Kanannado was obtained in seeds of plants sown on 11<sup>th</sup> and 25<sup>th</sup> August as well as 1<sup>st</sup> July (1.79, 1.81 and 1.31 respectively). None of IT93K-452-1 seeds completely lost its vigour throughout the storage

period. However, the highest vigour was recorded in seeds of plants sown between 28<sup>th</sup> July and 25<sup>th</sup> August (3.61 -4.07) followed by those sown on other planting dates (1.40 -2.16) except seeds produced by plants sown on 19<sup>th</sup> May which had the least vigour (0.42) at late storage.

## DISCUSSION

The significantly lower grain yield recorded in Kanannado plants sown early could be attributed to the photoperiod sensitivity of the variety which made those planted early to flower late. This conforms with the earlier report of Dudge *et al.* (2009) who reported that when cowpeas are planted early, photosensitive varieties (semierect and prostrate varieties) will not flower but grow very leafy and yield may be reduced. The significantly higher GP and seedling weight recorded in Kanannado during early storage in this study could be as a result of its larger seed size. Genetic variation is the cause of variation in size of seed between varieties. This is caused by flow of nutrients into the seed on the mother plant. Larger seeds mobilize food reserves better to the growing seedlings (Creech, 2012). Roy *et al.* (1996) reported that germination rate and seedling vigour index values increased with increase in seed size of rice. Though Kanannado seeds had the significantly highest GP at early storage, this did not translate to highest vigour in Kanannado seeds. This result is similar to the report of Creech (2012) who asserted that seeds can be viable and have low vigour which results in low rates or speed of germination. Causes of low seed vigour can include any combination of the following: genetic constitution, environment and nutrition of mother-plant, stage of maturity at harvest, seed size and weight, mechanical integrity, deterioration and ageing, and pathogens (AOSA, 2002). Highly vigorous seeds can withstand severe field conditions which increase the yield of crop.

The variation in the viability, vigour and longevity of the three varieties is in line with the report of Ibrahim *et al.* (2017) who reported that seed quality vary with genotype. Stewart *et al.* (1999) equally observed that germination characteristics are driven by the genetics of each plant and also influenced by maternal environment.

The decline in viability and vigour of seeds with storage time suggests that deterioration sets in as the seeds age. Deterioration of seeds occur as decrease in germination percentage, production of weak seedlings, loss of vigour, which leads to reduced viability and ultimately seed death. The rate of deterioration in seeds fluctuates critically from one variety to the other (Akintobi *et al.*, 2017). In this



study, the rate of deterioration was faster in Oloyin followed by Kanannado and IT93K-452-1 had the least, indicating that IT93K-452-1 is of higher longevity than the other two varieties. The significantly higher seed yield, vigour and longevity recorded in IT93K-452-1 is not surprising because it is an improved variety compared to the other two which are landraces. This indicates that it is of superior physiological and genetic quality. This further confirms the need to use improved varieties to improve the yield of cowpea.

#### **CONCLUSION AND RECOMMENDATIONS**

It is concluded from this study that IT93K-452-1 had the highest seed yield and quality among all the tested varieties and planting around 11<sup>th</sup> of August is recommended for cowpea farmers in the study area for optimum seed yield and quality.



**Table 4: Interaction between planting date and variety on germination percentage of cowpea at 0 and 8 weeks in storage (WIS)**

**Table 1: 100-seed weight of three cowpea varieties sown at different planting date**

Planting date	Variety		
	Oloyin	Kanannado	IT93K-452-1
19 <sup>th</sup> May	20.94hij	27.55abc	22.18gh
2 <sup>nd</sup> June	21.27ghi	26.98bc	20.30ijk
16 <sup>th</sup> June	22.23gh	27.72abc	19.75jk
1 <sup>st</sup> July	21.94gh	28.59a	21.18ghi
14 <sup>th</sup> July	21.27ghi	28.22ab	19.77jk
28 <sup>th</sup> July	22.40g	26.68cd	20.38ijk
11 <sup>th</sup> August	24.72ef	27.21bc	19.27k
25 <sup>th</sup> August	24.01f	27.02bc	19.82jk
8 <sup>th</sup> September	22.13gh	25.27de	20.32ijk
SE <sub>±</sub>		0.46	

Means with dissimilar alphabets are significantly different using LSD at P=0.05, SE- standard error of the mean.

**Table 2: Seed yield of three cowpea varieties sown at different planting date**

Planting date	Variety		
	Oloyin	Kanannado	IT93K-452-1
19 <sup>th</sup> May	1506.11bc	175.51kl	2013.501a
2 <sup>nd</sup> June	790.81e-j	461.09jkl	1270.50c-e
16 <sup>th</sup> June	1042.09c-g	548.25h-k	1424.32cd
1 <sup>st</sup> July	1447.23bcd	180.97kl	1927.11ab
14 <sup>th</sup> July	1155.44c-e	141.94l	1183.41cde
28 <sup>th</sup> July	975.24d-i	997.99d-h	1137.40c-e
11 <sup>th</sup> August	1066.35c-f	637.34f-k	1307.23cd
25 <sup>th</sup> August	429.67jkl	261.20kl	486.79i-l
8 <sup>th</sup> September	365.15jkl	198.75kl	570.82g-k
SE <sub>±</sub>		173	

Means with dissimilar alphabets are significantly different using LSD at P=0.05, SE- standard error of the mean.

**Table 3: Germination percentage of cowpea varieties at different storage period as affected by planting date**

Treatments	Weeks in storage				
	0	2	4	6	8
<b>Planting date (P)</b>					
19 <sup>th</sup> May	60.44f	57.77d	30.66c	14.66e	3.11d
2 <sup>nd</sup> June	61.33f	58.66d	28.00c	16.00e	9.77bc
16 <sup>th</sup> June	74.66e	83.11c	60.00b	32.88cd	11.55bc
1 <sup>st</sup> July	80.00d	80.44c	65.33b	27.55cd	9.33bc
14 <sup>th</sup> July	90.22bc	94.66b	77.77a	32.44cd	6.66cd
28 <sup>th</sup> July	88.89c	93.77b	84.00a	37.77c	14.66b
11 <sup>th</sup> August	97.77a	100.00a	99.22a	50.66b	20.44a
25 <sup>th</sup> August	99.11a	99.55a	86.66a	61.33a	23.11a
8 <sup>th</sup> September	95.11ab	97.33ab	82.22a	23.11de	6.66cd
<b>Varieties (V)</b>					
Oloyin	59.25c	64.88c	48.59b	17.33c	4.29c
Kanannado	98.66a	98.37a	76.00a	24.00b	9.18b
IT93K-452-1	91.25b	91.85b	77.03a	57.48a	21.63a
Interaction					
P x V	**	**	**	**	**

Means with dissimilar alphabets are significantly different using LSD at P=0.05, \*\* -significant at P=0.01.

**Table 7: Speed of germination of cowpea varieties at different storage period as affected by planting date**

Planting date	Oloyin		Variety Kanannado		IT93K-452-1	
	0 WIS	8 WIS	0 WIS	8 WIS	0 WIS	8 WIS
19 <sup>th</sup> May	7.33g	0.00h	100.00a	0.00h	81.33c	9.33g
2 <sup>nd</sup> June	14.67f	0.00h	100.00a	14.67efg	69.33d	14.67efg
16 <sup>th</sup> June	34.67e	0.00h	100.00a	10.67g	89.33bc	24.00bcd
1 <sup>st</sup> July	42.67e	0.00h	100.00a	12.00fg	97.33ab	16.00d-g
14 <sup>th</sup> July	72.00d	0.00h	98.67a	0.00h	100a	20.00c-f
28 <sup>th</sup> July	70.67d	0.00h	96.00ab	10.67g	100a	33.33a
11 <sup>th</sup> August	98.67a	16.00d-g	100.00a	17.33d-g	94.67ab	28.00abc
25 <sup>th</sup> August	100.00a	22.68b-c	100.00a	17.33d-g	97.33ab	29.33ab
8 <sup>th</sup> September	100.00a	0.00h	93.33ab	0.00h	92.00ab	20.00c-f

Means with dissimilar alphabets are significantly different using LSD at P=0.05, WIS- weeks in storage

**Table 5: Seedling weight of cowpea varieties at different storage period as affected by planting date**

Treatments	Weeks in storage				
	0	2	4	6	8
<b>Planting date (P)</b>					
19 <sup>th</sup> May	0.64d	0.53e	0.34c	0.18d	0.10d
2 <sup>nd</sup> June	0.85bc	0.69cd	0.49b	0.23d	0.22c
16 <sup>th</sup> June	0.78c	0.73bc	0.72a	0.35d	0.30bc
1 <sup>st</sup> July	1.01a	0.64cd	0.76a	0.34c	0.31b
14 <sup>th</sup> July	1.03a	0.60ed	0.57b	0.45b	0.13d
28 <sup>th</sup> July	0.89b	0.81ab	0.74a	0.47b	0.29bc
11 <sup>th</sup> August	0.92b	0.89a	0.77a	0.72a	0.55a
25 <sup>th</sup> August	0.78c	0.73c	0.76a	0.69a	0.51a
8 <sup>th</sup> September	0.78c	0.74bc	0.57b	0.52b	0.14d
SE±	0.010	0.011	0.015	0.011	0.008
<b>Varieties (V)</b>					
Oloyin	0.67c	0.58c	0.31c	0.31c	0.11c
Kanannado	1.09a	0.87a	0.76a	0.45b	0.27b
IT93K-452-1	0.80b	0.68b	0.64b	0.56b	0.47a
SE±	0.031	0.034	0.045	0.033	0.027
Interaction					
P x V	**	**	**	**	**

Means with dissimilar alphabets are significantly different using LSD at P=0.05, SE- standard error of the mean,

**Table 6: Interaction effect of planting date and variety on seedling weight at 0 and 8 WIS**

Planting date	Variety						
	Oloyin	0 WIS			8 WIS		
		Kanannado	IT93K-452-1		Oloyin	Kanannad	IT93K-452-1
19 <sup>th</sup> May	0.12o	1.06cd	0.88f-j	0.00i	0.00i	0.29gh	
2 <sup>nd</sup> June	0.46n	1.16bc	0.96d-i	0.00i	0.25h	0.43ef	
16 <sup>th</sup> June	0.66m	0.93d-l	0.77j-m	0.00i	0.32fgh	0.58abc	
1 <sup>st</sup> July	0.90e-j	1.29ab	0.83g-k	0.00i	0.45c-f	0.49a-e	
14 <sup>th</sup> July	0.89f-j	1.38a	0.82h-l	0.00i	0.00i	0.41efg	
28 <sup>th</sup> July	0.82i-l	1.05cde	0.82h-l	0.00i	0.44def	0.46b-e	
11 <sup>th</sup> August	0.98d-g	0.97d-h	0.81i-l	0.56a-d	0.52a-e	0.59a	
25 <sup>th</sup> August	0.69k-m	1.00def	0.68lm	0.49a-e	0.48a-e	0.59a	
8 <sup>th</sup> September	0.72km	0.97dh	0.65m	0.00i	0.00i	0.44def	
SE±		0.05			0.05		

Means with dissimilar alphabets are significantly different using LSD at P=0.05, SE- standard error of the



Treatments	Weeks in storage				
	0	2	4	6	8
<b>Planting date (P)</b>					
19 <sup>th</sup> May	13.94e	9.17e	5.76d	2.86de	0.56f
2 <sup>nd</sup> June	13.64e	11.98d	5.22d	2.02e	1.12ef
16 <sup>th</sup> June	17.67d	14.19c	12.70c	4.29cd	2.63c
1 <sup>st</sup> July	19.30cd	13.76cd	13.44c	4.54cd	2.56cd
14 <sup>th</sup> July	21.67bc	17.60b	18.44b	4.94c	1.46def
28 <sup>th</sup> July	19.62cd	18.13b	20.89ab	5.57c	3.86b
11 <sup>th</sup> August	25.38a	22.68a	22.22a	7.92b	4.73ab
25 <sup>th</sup> August	26.10a	22.67a	21.98a	11.97a	5.83a
8 <sup>th</sup> September	22.51b	18.37b	20.27ab	4.05cd	1.79cde
SE±	1.01	0.77	1.13	0.69	0.40
<b>Varieties (V)</b>					
Oloyin	14.89b	12.84b	10.85b	2.69b	0.86c
Kanannado	22.19a	18.25a	18.60a	3.26b	2.07b
IT93K-452-1	22.85a	18.43a	17.53a	10.09a	5.22a
SE±	0.59	0.44	0.66	0.40	0.23
Interaction					
P x V	**	**	**	**	**

Means with dissimilar alphabets are significantly different using LSD at P=0.05, SE- standard error of the mean,

**Table 8: Interaction effect of planting date and variety on speed of germination at 0 and 8 WIS**

Treatments	Variety						
	Planting date	0 WIS			8 WIS		
		Oloyin	Kanannado	IT93K-452-1	Oloyin	Kanannado	IT93K-452-1
19 <sup>th</sup> May	1.32j	24.91abc	16.91gh	0.00h	0.00h	1.67gh	
2 <sup>nd</sup> June	3.52ij	24.57abc	12.81h	0.00h	1.52gh	1.52gh	
16 <sup>th</sup> June	7.24i	20.57c-g	25.19abc	0.00h	2.38fg	5.52bc	
1 <sup>st</sup> July	6.86i	26.57ab	24.48a-d	0.00h	3.43d-g	4.24c-f	
14 <sup>th</sup> July	18.57e-g	19.52d-g	26.91ab	0.00h	0.00h	4.38cde	
28 <sup>th</sup> July	16.86gh	17.76fgh	24.24a-d	0.00h	2.71efg	8.86a	
11 <sup>th</sup> August	27.86a	22.24b-f	26.05ab	3.24e-g	3.95c-f	7.00a	
25 <sup>th</sup> August	27.24a	24.91abc	26.14ab	4.48cde	4.62cde	8.38a	
8 <sup>th</sup> September	25.91ab	18.67e-g	22.95a-e	0.00h	0.00h	5.38bcd	
SE±		1.75			0.70		

Means with dissimilar alphabets are significantly different using LSD at P=0.05, SE- standard error of the mean,

**Table 9: Seedling vigour index of cowpea varieties at different storage period as affected by planting date**

Treatments	Weeks in storage				
	0	2	4	6	8
<b>Planting date (P)</b>					
19 <sup>th</sup> May	7.47e	10.27ef	7.00d	1.36f	0.14d
2 <sup>nd</sup> June	7.96de	10.20ef	5.98d	1.56f	0.89c
16 <sup>th</sup> June	6.94e	12.64cd	12.63c	4.77de	0.85c
1 <sup>st</sup> July	10.76c	9.21f	15.59bc	4.10e	0.96c
14 <sup>th</sup> July	15.47b	11.68de	20.55a	6.12d	0.47cd
28 <sup>th</sup> July	15.66b	15.38b	20.85a	8.43c	1.67b
11 <sup>th</sup> August	21.49a	20.81a	22.39a	11.30b	2.27a
25 <sup>th</sup> August	15.75b	14.33bc	17.11b	13.62a	2.45a
8 <sup>th</sup> September	10.11cd	8.04	17.39b	4.44de	0.72c
SE±	0.83	0.67	1.10	0.68	0.20
<b>Varieties (V)</b>					
Oloyin	9.73c	9.77c	10.86c	2.52c	0.40c
Kanannado	11.68b	11.43b	14.98b	3.97b	0.77b
IT93K-452-1	15.79a	16.32a	20.65a	12.07a	2.31a
SE±	0.48	0.39	0.64	0.40	0.12
Interaction					
P x V	**	**	**	**	**

Means with dissimilar alphabets are significantly different using LSD at P=0.05, SE- standard error of the mean

**Table 10: Interaction effect of planting date and variety on seedling vigour index at 0 and 8 WIS**

Planting date	Variety			Variety		
	Olovin	0 WIS Kanannado	IT93K-452-1	Olovin	8 WIS Kanannado	IT93K-452-1
19 <sup>th</sup> May	0.00l	8.67ij	13.74fgh	0.00g	0.00g	0.42ef
2 <sup>nd</sup> June	0.00l	11.63ghi	12.24ghi	0.00g	0.67d-g	1.99b
16 <sup>th</sup> June	4.28k	6.53jk	10.04hij	0.00g	0.40fg	2.16b
1 <sup>st</sup> July	4.48k	11.50ghi	16.31def	0.00g	1.31b-f	1.58bcd
14 <sup>th</sup> July	14.03e-h	14.67efg	17.90b-e	0.00g	0.00g	1.40b-e
28 <sup>th</sup> July	12.19ghi	14.25efg	20.53abc	0.00g	0.93c-g	4.07a
11 <sup>th</sup> August	20.90ab	19.77a-d	23.80a	1.62bcd	1.79bc	3.40a
25 <sup>th</sup> August	18.63bcd	12.00ghi	16.61c-f	1.94b	1.81bc	3.61a
8 <sup>th</sup> September	13.13fgh	6.27jk	10.92ghi	0.00g	0.00g	2.16b
SE <sup>‡</sup>		1.43			0.35	

Means with dissimilar alphabets are significantly different using LSD at P=0.05, SE- standard error of the mean, WIS-

**REFERENCES**

- Akintobi, D. C. A and Olumide, O. B. (2017). Effect of storage time on vigour and viability of cowpea varieties. *Nigerian Journal of Seed science*, 1, 29-39.
- Association of Official Seed Analysts (AOSA) (2002). Rules for testing seeds. Las Cruces, New Mexico
- Creech, C. F. (2012) Effects of Planting Date, Harvest Date, and Environmental Conditions on Germination of Forage Kochia Accessions *All Graduate Theses and Dissertations*. 1264. [https://digitalcommons.usu.edu/etd/1264 pp 1-87](https://digitalcommons.usu.edu/etd/1264_pp_1-87)
- De-Souza, P. I., Egli, D. B. and Bruening, W. P. (1997). Water stress during seed filling and leaf senescence in soybean. *Agronomy Journal*, 89, 807-812.
- Dugje, I. Y., Omoigu, L. O., Ekeleme, F., Kamara, A. Y., Ajeigbe H. (2009). Farmers' guide to cowpea production in West Africa. IITA Ibadan Nigeria. ISBN 979-131-332-3. [www.iita.org/c/document](http://www.iita.org/c/document)
- Elnesr, M. N., Alazba, A.A. and Alsadon, A.A. (2013). An arithmetic method to determine the most suitable planting dates for vegetables. *Computers and Electronics in Agriculture*. 90, 131-143.
- Ibrahim, H., Kadiri, F. R., Yusuf, S. T., Tolorunse, K. D. and Oladiran J. A. (2017). The quality of seeds of different cultivars of pepper (*Capsicum annum* Linn.) processed by different methods. *Nigerian Journal of Seed Science* (NJSS) 1, 1-20.
- Odindo, A. (2007). Cowpea seed quality in response to water stress and production site. PhD Thesis, University of KwaZuluNatal, Pietermaritzburg Pp 1-264.
- Omosho, S. O. (2014). Influence of NPK 15-15-15 fertilizer and pig manure on nutrient dynamics and production of cowpea, *Vigna unguiculata* L. Walp. *American Journal of Agriculture and Forestry* 2(6), 267-273.
- Pule-Meulenberg, F., Alphonsus, K. B., Krowade, T. & Dakora F. D. (2010). Symbiotic functioning and bradyrhizobia biodiversity of cowpea (*Vigna unguiculata* L. Walp) in Africa. *Microbiology*, 10, 89-101.
- Roy, S. K. S., Hamid, A. Miah, M. G. and Hashem, A. (1996). Seed size variation and its effects on germination and seedling vigour in Rice. *Journal of Agronomy and Crop Science*, 176, 79-82.
- Smith, A. R. and Zhao, D. (2016). Sterility caused by floral organ degeneration and abiotic stresses in *Arabidopsis* and cereal grains. *Frontiers in Plant Science* 7, 1503.
- Stewart A., Anderson, V. J. and Kitchen, S. G. (1999). 'Immigrant' forage kochia (*Kochia prostrata*) seed germination as affected by storage conditions. In McArthur E.D., Ostler W.K., Wambolt C.L.(comps.), Proceedings, Shrubland Ecotones; August 12-14; Ephraim, Utah. RMRS-P11. USDA Forest Service, Rocky Mountain Research Station, Ogden, Utah. Pp.274-279.
- Sun, Q., Wang, J. H. and Sun, B. Q. (2007) Advances on seed vigor physiological and genetic mechanisms. *Agricultural Science in China*.6(9), 1060-1066. doi: 10.1016/S1671-2927(07)60147-3.

**EFFECT OF ROASTED SENNA *OCCIDENTALIS* SEED MEAL ON THE CARCASS CHARACTERISTICS, MEAT TO BONE RATIO AND ORGAN PROPORTION OF INDIGENOUS GUINEA FOWLS (*NUMIDEA MELEAGRIS GALLEATA*) UNDER INTENSIVE SYSTEM**

**Kudu, Y.S., Ayanwale, B.A., Aremu, A.T., Ijaiya, A.A., Malik and M.J. Ibrahim**

**Department of Animal Production, Federal University of Technology, Minna, Nigeria**

**Corresponding Author's e-mail: yahaya.kudu@futminna.edu.nd**

**ABSTRACT**

*A total of one hundred and eighty guinea fowls keets were used in this experiment under intensive system management. The keets were randomly allotted to four treatments, replicated three times with 15 keets each in a completely randomized design (CRD). Four diets were formulated, such that treatment 1 contained 0% with no roasted Senna occidentalis seed meal (RSOM) and served as the control, while treatment 2, 3 and 4 contained 5.50%, 11.0% and 16.50% RSOM respectively. The result showed that guinea fowls fed diet 1 recorded the highest live weight (1183.00g) and slaughter weight (975g), although significant differences ( $p < 0.05$ ) were recorded in most parameters, guinea fowls fed 5.50% RSOM recorded the highest dressing percentage with no significant differences ( $p > 0.05$ ) in thigh, back and drumstick among the treatment groups. However, significant differences ( $p < 0.05$ ) were observed in the values of the meat to bone ratio, with guinea fowls fed treatment 1 (0.0% RSOM) recording higher ratios for the thigh, drumstick, breast and the wing, however, the guinea fowls fed treatment 2 recorded higher ratio with 2.39. The results of the organ proportions indicated significant differences ( $p < 0.05$ ) in most of the parameters measured, though does not follow a specific pattern, however, non-significant differences ( $p > 0.05$ ) were observed in the heart and the lungs amongst all the dietary groups. From the results obtained from this experiment, it can be recommended that 5.50% RSOM can be included in the diets of growing guinea fowls without any adverse effects*

**KEY WORDS:** Guinea fowl keets, *Senna occidentalis*, carcass characteristics, meat to bone ratio, organ

**INTRODUCTION**

The protein consumption level in Nigeria is about 27 g which is less than the minimum requirement of 35 g recommended by the National Research Council of the United States of America (NRC, 1998). Going by the current Nigerian population of over 140 million (NPC, 2006), to meet the recommended 35 g of animal protein per person per day, an average meat supply of 4.9 million Kilograms per day will be required (Yahaya, 2014). Although a trend of increase of about 4.83 % has been observed in the livestock industry (Ojiako and Olayode, 2008), this level of increase is too low to meet up with the animal protein requirement of every Nigerian. However, the potential of poultry in alleviating the problem of protein inadequacies in human nutrition in developing countries is becoming less realizable (Ari, 2006). This has been attributed to insufficient supply of and high cost of certain conventional ingredients such as soybean; groundnut, maize and wheat, in addition to animal protein sources particularly fish meal. In recent time, operators of livestock industries because of high cost of feed ingredients have compromised the standards of commercial feeds (Kudu, 2008a). It is a common knowledge that the proximate composition obtained from the labels of some commercial feeds fall below the requirement of

birds as was observed by Kudu *et al.* (2008a) after subjecting some commercial feeds to chemical analysis.

The search for novel high quality but cheap sources of protein and energy has continued to be a major source of concern to scientists and bodies charged with the responsibility for food in many parts of the developing world (Kudu, 2010). These situations of inadequacies are aggravated by inadequate viable information on the composition and utilization of many varied protein and energy sources of legumes indigenous to the tropics. The problem is also made worse by unavailability of other proteins of animal origin in sufficient quantities which makes the use of protein rich legumes to be an essential alternative in poultry nutrition. Inadequate ingredients and high cost of poultry birds have created the need for research into alternative feed ingredients that have high nutritive value and are readily available. However, most plant legumes such as Negro coffee (*Senna occidentalis*) contain antinutritional factors (ANF) like trypsin inhibitors, cyanides, phytic acids and tannins that limit their use in monogastric diets. Presently, Negro coffee is not in use as a source of protein in both human and poultry production. Interestingly, the eggs of wild guinea fowls are suitable for hatching by modern incubators (Kudu *et*



al.,2010). The collected eggs from the wild are mostly fertile and obtained at low cost.

Roasting has been noted to improve the nutritive quality of some leguminous plant seeds (Tiamiyu, 2001; Ari, 2006; Udensi et al., 2008). Legume seeds are usually limited in their use because of anti nutritional factors particularly, tannin, trypsin inhibitor, phytic acid and saponin (Udensi et al., 2005; Kudu et al., 2010). This necessitates the need to determine the impact of roasted *Senna occidentalis* meal on the carcass, meat to bone ratio and organ proportions of the wild indigenous guinea fowls under intensive system.

#### MATERIALS AND METHODS

**Experimental Site:** This experiment was carried out at the poultry unit of the Department of Animal Production, Teaching and Research Farm situated at the Bosso Campus, Federal ; University of Technology ,Minna.Niger State.

#### Experimental diets

The roasted *Senna occidentalis* seed meal (RSOM) was used to prepare 4 different experimental diets at the grower phase. Roasting method of Cheva-Isarakul and Tangta Weewipat (1995) was used, while antinutritional factors (ANF) were determined at the Biochemistry Laboratory at the National Cereals Research Institute Baddegi, Niger State, using the methods described by Onwuka (2012). T<sub>1</sub> contained 0.00 % roasted *Senna occidentalis* meal (RSOM) while T<sub>2</sub>, T<sub>3</sub> and T<sub>4</sub> contained 5.5, 11.0 and 16.50 % of roasted *Senna occidentalis* meal respectively. Each of the chicks' diets was formulated to contain 22 % CP and 3100 Kcal/Kg ME. The diets were isocaloric and isonitrogenous (Table 1).

#### Management of experimental birds

A total of one hundred and eighty (180) 10 weeks old guinea fowl keets were used for the experiment. The birds were randomly divided into 4 treatment groups. Each treatment had 3 replicates with 15 guinea fowl keets. Four experimental chick diets (Table.1) were fed to the guinea fowl keets for the period of 10 weeks. Under intensive management.

#### Experimental design

The experimental design was complete randomized design (CRD)

#### Results and Discussion

Table 2 indicated significant difference ( $P < 0.05$ ) in the final weight, slaughter weight, dressing percentage, while non – significant difference ( $P > 0.05$ ) was recorded in breast, thigh, back and the drumstick. The guinea fowls fed the control diet (T<sub>1</sub>) recorded the highest live weight (1183.05) this decreases progressively as the inclusion level of RSOM increase in the diet of the guinea, similarly the breast, drumstick decrease as the inclusion level increase in the diet. The trend of result obtained in this experiment, with specific reference to dressing percentage, slaughter percentage agrees with Nobo

et al. (2012) who reported dressing percentage, slaughter percentage in guinea fowls fed 18% - 26% CP, with over 3100 ME/Kcal/kg, who fed varying levels of Phane meal (*Imbrasis belina*) as a replacement for fish meal. Dahouda et al. (2009) reported that when guinea fowls were fed up to 20% roasted Mucuna, a dressing percentage in some parameters, like thigh and drumstick was about 72.40 %, and concluded that roasting improves the utilization of legumes by reducing ANF particularly L. Dopa to 36 – 52%, in a similar experiment reported by Yahaya 2014; trypsin inhibitors, cyanide were respectively reduced by 61.76% and 41.8% respectively, the trend of this carcass characteristics might be attributed to residual effect of the mentioned ANF since they were not completely removed (kudu et al., 2018).

Table 2 show the meat to bone ratio of the guinea fowls fed roasted RSOM at various inclusion levels. The parameters measured included, the thigh, drumstick, breast, wing and breast, significant difference were ( $P < 0.05$ ) were observed in all the parameters measured. The meat to bone ratio tends to increase as the level of RSOM increases in the diet, with highest ratio obtained in the thigh and breast ranges from 7.24 to 11.04 and 6.77 to 11.17 respectively. The result obtained in this experiment agrees with Embury (2011) and Oke et al. (2012) that guinea fowls are table bird with game type flavor and high meat to bone ratio which led to their world wide acceptance. Moreki and kelemigile (2012) had reported similar values which showed that guinea fowl had a relatively high meat to bone ratio, this results are in agreement with Yahaya (2014).

Table 4 shows the effect of roasted *Senna occidentalis* meal on the organs of the guinea fowl significant difference ( $P > 0.05$ ) were observed in all the parameters measured, except, the heart and lungs. The significant difference observed in the liver (%) might be attributed to higher, inclusion level of RSOM in treatment 4, where the highest liver percentage was recorded, which differs from T<sub>1</sub>, T<sub>2</sub> and T<sub>3</sub>, similar trend of significant difference ( $P < 0.05$ ) was recorded in the values of the kidney, with T<sub>4</sub> record the highest value. The significant difference observed in the gizzard proportion might be attributed to high feed content, this might have caused the gizzard to expand and the intestine to increase in length to cope with handling properties (Akpodiete et al., 2006) the abdominal deposit increase as the level of RSOM increased, this might be attributed to a higher Bio – availability of metabolizable energy (Esuga, 2008).

#### Conclusion

The experiment showed that RSOM could be a source of nutrient in the diets of growing guinea fowls provided the anti-nutritional factors are been removed through roasting, although its inclusion level cannot exceed 5.5% in the diet, other

processing methods could be employed to further enhance its usage in the diets of domestic animals.

**Table 1: Composition of experimental diets containing roasted *Senna occidentalis* seed meal at chick phase**

Ingredients	Levels of roasted <i>Senna occidentalis</i> seed meal (%)			
	0.00	6.50	13.00	19.50
Maize	44.70	40.20	35.70	28.87
GNC	41.70	39.50	37.70	38.03
RSOM	0.00	6.50	13.00	19.50
Maize bran	5.00	5.00	5.00	5.00
Fish meal	4.00	4.00	4.00	4.00
Bone meal	2.50	2.50	2.50	2.50
Red oil	0.30	0.30	0.30	0.30
Lysine	1.10	1.10	1.10	1.10
Methionine	0.45	0.45	0.45	0.45
*Premix	0.25	0.25	0.25	0.25
TOTAL	100.00	100.00	100.00	100.00
<b>Calculated values</b>				
Energy (Kcal/Kg/ME)	2995	2990	2988	3000.30
Crude protein (%)	25.91	25.85	25.95	26.05
Crude fibre (%)	3.80	3.24	3.59	3.49
Ether extract (%)	5.98	5.73	5.50	5.31
Calcium (%)	1.46	1.47	1.53	1.58
Phosphorus (%)	0.92	1.05	0.99	1.03
Lysine (%)	2.11	2.27	2.41	2.58
Methionine (%)	0.82	1.76	2.17	2.62

\*To provide the following per 100 Kg of the diet: 440 mg riboflavin; 720 mg calcium pantothenate; 2 g niacin; 2.2 g chloride; 15 mg folic acid; 1 mg vitamin B12; 15 mg retinol; 165 g vitamin D2; 1000 mg DL-tocopherol acetate; 1700 mg Copper; 200 mg Iodine; 3000 mg Manganese; 5000 mg Zinc; 10,000 mg Iron.

**Table 2: Effect of roasted *Senna occidentalis* seed meal on the carcass characteristic of guinea**

Parameters	Levels of RSOM (%)				SE	LS
	0.00	5.50	11.00	16.50		
Live weight (g)	1183.00 <sup>a</sup>	966.6 <sup>b</sup>	808.7 <sup>b</sup>	623.3 <sup>c</sup>	65.49	**
Slaughter weight (g)	9759 <sup>a</sup>	8453 <sup>b</sup>	7103 <sup>c</sup>	5399 <sup>d</sup>	171.69	**
Dressing (%)	72.01	76.69	74.63	70.63	0.74	ns
Head (%)	2.30 <sup>a</sup>	2.54 <sup>ab</sup>	2.69 <sup>ab</sup>	3.13 <sup>b</sup>	0.12	**
Neck (%)	4.02	4.63	4.09	4.37	0.16	ns
Wing (%)	7.75 <sup>c</sup>	9.42 <sup>b</sup>	10.34 <sup>b</sup>	11.54 <sup>a</sup>	1.54	**
Breast (%)	23.1 <sup>b</sup>	22.24 <sup>b</sup>	21.35 <sup>b</sup>	16.24 <sup>a</sup>	0.95	**
Thigh (%)	11.74	12.76	11.55	11.20	0.26	ns
Drumstick (%)	11.8 <sup>a</sup>	10.43 <sup>a</sup>	10.54 <sup>a</sup>	9.98 <sup>a</sup>	0.29	**
Back (%)	11.09	11.70	10.75	10.30	0.23	ns
Shank (%)	2.36	2.31	2.53	2.79	0.07	Ns

GNC= Groundnut Cake; RSOM= Roasted *Senna occidentalis* meal.

a,b,c,d: Means in the same row with different superscripts are statistically ( $P < 0.05$ ) different ( $P < 0.05$ ); \*\*: Significant; SE: Standard error; LS: Level of significance; ns : not significant ( $P > 0.05$ ).

**Table.3. Effect of roasted *Senna occidentalis* seed meal on the meat to bone ratio of wild indigenous guinea fowl**

Parameters	Levels of RSOM (%)				SE	LS
	0.00	5.50	11.00	16.50		
Thigh	9.74 <sup>ab</sup>	11.04 <sup>a</sup>	8.04 <sup>b</sup>	7.24 <sup>b</sup>	0.57	**
Drumstick	6.87 <sup>a</sup>	5.79 <sup>b</sup>	5.46 <sup>b</sup>	5.16 <sup>b</sup>	0.23	**
Breast	11.17 <sup>a</sup>	10.38 <sup>a</sup>	6.77 <sup>b</sup>	6.98 <sup>b</sup>	0.63	**
Wing	2.09 <sup>a</sup>	2.74 <sup>b</sup>	2.79 <sup>b</sup>	2.85 <sup>b</sup>	0.12	**
Back	2.39 <sup>b</sup>	3.05 <sup>a</sup>	2.15 <sup>b</sup>	2.28 <sup>b</sup>	0.13	**

a,b,c,d: Means in the same row with different superscripts are statistically ( $P < 0.05$ ) different ( $P < 0.05$ ); \*\*: Significant; SE: Standard error; LS: Level of significance; ns : not significant ( $P > 0.05$ ).

**Table 4: Effect of roasted *Senna occidentalis* seed meal on organ proportions of guinea fowl**



Parameters	0.00	5.50	11.00	16.50	SE	LS
Intestine weight (%)	1.97 <sup>c</sup>	2.40 <sup>c</sup>	3.83 <sup>b</sup>	4.70 <sup>a</sup>	0.35	**
Gizzard (%)	1.62 <sup>c</sup>	2.65 <sup>b</sup>	3.03 <sup>a</sup>	2.89 <sup>b</sup>	0.17	**
Crop (%)	1.75 <sup>c</sup>	2.64 <sup>b</sup>	3.04 <sup>b</sup>	4.59 <sup>a</sup>	0.32	**
Gall bladder (%)	0.11	0.16	0.11	0.11	0.01	ns
Heart (%)	0.56	0.47	0.46	0.43	0.03	Ns
Lungs (%)	0.54	0.33	0.56	0.54	0.05	Ns
Proventriculus (%)	0.37 <sup>bc</sup>	0.33 <sup>c</sup>	0.41 <sup>b</sup>	0.53 <sup>a</sup>	0.02	**
Liver (%)	1.32 <sup>b</sup>	1.28 <sup>b</sup>	1.52 <sup>ab</sup>	1.70 <sup>a</sup>	0.06	**
Abdominal fat (%)	0.14 <sup>b</sup>	0.16 <sup>ab</sup>	0.14 <sup>b</sup>	0.22 <sup>a</sup>	0.01	**
Kidney (%)	0.35 <sup>b</sup>	0.57 <sup>a</sup>	0.38 <sup>b</sup>	0.59 <sup>a</sup>	0.04	**
Intestine (cm)	100.07 <sup>a</sup>	113.67 <sup>ab</sup>	109.33 <sup>b</sup>	125.27 <sup>a</sup>	3.19	**
Right caecum (cm)	13.00 <sup>b</sup>	13.17 <sup>b</sup>	13.80 <sup>b</sup>	17.57 <sup>a</sup>	0.71	**
Left caecum (cm)	13.10	14.33	15.20	15.53	0.49	Ns
Spleen (%)	0.06 <sup>ab</sup>	0.05 <sup>b</sup>	0.07 <sup>a</sup>	0.07 <sup>ab</sup>	0.03	**

<sup>a,b,c,d</sup>: Means in the same row with different superscripts are statistically (P<0.05) different (P<0.05); \*\*: Significant; SE: Standard error; LS: Level of significance; ns : not significant (P>0.05).

#### Reference

- Akpodiete, O.J., Eruvbetine, D., & Gagiyovwe, E.E. (2006) effects of enzyme supplementation on palm kernel cake based diets on broiler chicken performance. *Nigeria Poultry Science Journal*, 4:39-46
- Ari, M.M (2006). An Evaluation of the effect of various processing methods on the Utilization of soybeans (*Glycine max*) by broilers. Ph.D.Thesis submitted to the Postgraduate school. Federal University of Technology, Minna.
- Dahouda, M., Toleba, S.S., Youssao, A.K.I., Mamali, A., Dangousapolo, R.K., Ahounou, S.G., Hambuckers, A. and Hornick, J.I. (2009). The effect of raw and processed *Mucuna puriens* seed based diets on the growth parameters and meat characteristics of Benin local guinea fowl (*Numida meleagris*, L) *International Journal of Poultry Science* 8(9):882-889.
- Esuga, P.M., Sekoni, A.A., Omege, J.I. & Bawa, G.S. (2008) Evaluation of enzyme (maxigrain®) supplementation of graded levels of palm kernel meal (PKM) on the performance of broiler chickens. *Pakistan Journal of Nutrition* 39(4) 254-257
- Kudu, Y. S., Alabi, J. O., Egena, S. S. A and Umaru M. A (2008a) The effect of four different commercial feeds on cockerel production. Proceedings of the 33<sup>rd</sup> Annual Conference of Nigerian Society for Animal Production. NSAP. 13<sup>th</sup> -16<sup>th</sup> March.. Ayetoro, Ogun state. Nigeria. Pp 443-445.
- Kudu, Y.S., Ayanwale, B.A., Shiawoya, E.L. A. Aremu, A., Jiya, E.Z. and Masodami, V. (2010). Growth performance of wild indigenous guinea fowls (*Numidea meleagris galeata*) fed graded levels roasted negro coffee (*Senna occidentalis*) seed meal. Proceeding of the 35<sup>th</sup> Annual Conference of the Society for Animal Production. (NSAP.) University of Ibadan, Nigeria. 14<sup>th</sup> -17<sup>th</sup> March, 2010.
- Kudu, Y.S., Mustapha, K., Jiya, E.Z., Malik, A.A., and Ibrahim M.J. (2018). Growth performance, carcass and economic characteristics of weaner rabbits fed varying levels of pelleted boiled negro coffee (*Senna occidentalis*) seed meal
- Moreki, J.C. and Kalemogile K. (2012) Bone development in guinea fowl fed diets

Containing three cereal grains as sources of energy up to 12 weeks of age.

*Journal of Animal Production Advances* 2(8): 365-372.

National Research Council (1998) .Nutrient requirements of poultry. 10<sup>th</sup> ed. National .Academy Press. Washington D.C.

Nobo,G.Moreki ,J,C and Nsoso,S.J.(2012)Feed intake,body weight,Avarege daily gain,feed

Conversion ratio and carcass characteristics of helmted guinea fowl fed varying

Levels of phane meal (*Imbrassive belina*) as a replacement of fish meal under

Intensive system.*International Journal of Poultry Science* 11(6):378-384

NPC (2006). National Population Census. Population Census of the Federal Republic of Nigeria (*Analytical Report of the national level. National Population Commission, Abuja, Nigeria*).

Ojiako, I.A and Olayode, G.O (2008). Analysis of Nigeria livestock production trends, 1990-2005: NSAP Proceedings of the 33<sup>rd</sup> Annual Conference of Nigerian Society for Animal Production. NSAP. 13<sup>th</sup> -16<sup>th</sup> March..Ayetoro , Ogun state.Nigeria .Pp : 308-311

Oke, U.K, C.A. Ariwodo, U. Herbert. S.N. Ukachuckwu, I.A Ukwani, A.H.

Akinmutimi, I.I. Ezeigbo and D.O chukwu (2012) Impact of egg size on the fertility and hatchability and early growth rates of two varieties of guinea fowl in a humid tropical environment. *Journal of Animal Science Advance*. 2 (Suppl.3.2); 299-305.

Onwuka, G.I. (2005) Food analysis and instrumentation, theory and practice, Printed by Naphthali Prints, A division of Hg support Nigerian Limited Surulere Lagos, Nigeria pp140-153

Tiamiyu, L. O. (2001). Nutritive value of heat processed full-fat soya bean (*Glycine max*) in diets for the African catfish (*clarius gariepinus*) fingerling.Ph.D thesis submitted to the Postgraduate school Federal University of Technology, Minna.

Udensi,E.A. Onwuka,G.I. and Onyekwere C.R. (2008). Effect of autoclaving and boiling on some antinutritional factors in *Mucuna solanie*. *Nigerian Food Journal* .33: 53-58

Yahaya. S.K. (2014). Performance and blood biochemical profile wild indigenous Guinea fowls fed differently processed Negro coffee (*Senna occidentalis*) seed meal underintensive system management. Ph.D. Thesis submitted to the postgraduate School, Federal University of Technology, Minna.

# EFFECTS OF BUTYLATED HYDROXY TOLUENE ON THE KEEPING QUALITY OF *KULIKULI*, A NIGERIAN SNACK.

James<sup>1\*</sup>, S., L. Nwokocho<sup>2</sup>, L. Akinsoji<sup>1</sup>, A. I. Baba<sup>1</sup>, Y. Audu<sup>1</sup>, Y. M. O. Maxwell<sup>1</sup>

<sup>1</sup>Department of Food Science and Technology, Federal University of Technology, PMB 65, Minna, Niger State, Nigeria

<sup>2</sup>Department of Hospitality and Tourism Management, Delta State Polytechnic, Ogwashi-Ukwu, Delta State, Nigeria.

\*Corresponding Author's E-mail: [samaila.james@futminna.edu.ng](mailto:samaila.james@futminna.edu.ng) GSM: 08062514350

## ABSTRACT

The effect of butylated hydroxy toluene (BHT), a synthetic antioxidant at different concentrations on the keeping quality of the groundnut snack was studied. Groundnut seeds were sorted, roasted, dehulled, winnowed and milled into a paste. The paste (2000 g) was then spiced with onion (65.3 g), pepper (20.3 g) and salt (39.4 g). To the paste, 400 ml of distilled water was added and the mixture was properly kneaded and pressed manually for oil extraction. After oil extraction, the resultant cake was weighed and divided into five equal portions (400 g each). To each portion of the cake 100 ppm, 150 ppm, 200 ppm, 250 ppm and 300 ppm butylated hydroxy toluene were added and properly mixed representing samples A, B, C, D and E respectively. The cake was shaped into cylindrical of nearly uniform thickness and deep fried until hard, crunchy, hard and dry brown snack. After drying, the snacks were cooled and packaged in a plastic container and stored at room temperature until need for analysis. The quality indices studied include peroxide value, free fatty acid, saponification value and sensory attributes. The result of the study showed that there was decrease levels of peroxide value, free fatty acid and saponification value with increased level of butylated hydroxy toluene over the storage period. For sensory attributes, all the parameters measured were not significantly influenced by different levels of butylated hydroxy toluene. Therefore, synthetic antioxidant investigated can be used at higher concentrations 200, 250 and 300 ppm for deterioration free groundnut snack production.

**KEYWORDS:** Groundnut, paste, cake, snack, free fatty acid, peroxide value, saponification.

## INTRODUCTION

Groundnut based local snack, *kulikuli* is a common snack in West Africa such as Ghana, Togo, Nigeria among others. The snack is popular in Northern part of Nigeria and its production and processing are mainly carried out by women as a source of income (Emelike and Akus, 2018; Desai *et al.*, 1996). The local snack is made from ground dry roasted groundnut (paste). Spices such as powdered pepper and other ingredients such as salt, sugar, onion are added to the paste and properly mixed together prior to frying. The paste is stripped of excess oil and the resulting cake is moulded into different shapes. The oil extracted from the paste is then heated to fry the shaped cake until it solidifies, hard, crunchy and allowed to cool before packaging in nylon or plastic containers or glass container (Desai *et al.*, 1996; Adebisin *et al.*, 2001).

The local snack is a good source of protein, fat, crude fibre, minerals as well as some B-group vitamins (Aletor and Ojelabi, 2007; Oladimeji and Kolapo, 2008). Due to high protein content of the snack, it makes it suitable as supplements for carbohydrates foods such as *gari* and *pap*. Ground form of the snack is seasoned with spices and used in the production of

local meat snack called *kilishi*. Furthermore, the snack is commercially used as a protein source in formulating feed for livestock (Akano and Atanda, 1990).

Deep-fat-frying of the cake affects the quality of the oil as well as that of the fried snack. It leads to the hydrolysis of poly unsaturated fatty acids and destruction of vitamin E which is a natural antioxidant. Degradation of the oil makes it susceptible to lipid oxidation (Damame *et al.*, 1990). This limits the shelf life and storage stability of both the oil and the fried snack. Furthermore, lipid oxidation reactions are accelerated by high temperature, presence light and oxygen exposure (Fontanella, 2015). The reactions in the snack lead to rancidity which shortens the shelf life and affects storage stability, texture and brings about off-flavour development and these affect the processing of the snack in commercial scale.

The development of rancidity in snacks can be eliminated by the use of food additives, especially anti-oxidants such as butylated hydroquinone (TBHQ), butylated hydroxy toluene (BHT), butylated hydroxy anisole (BHA) (Fontanella, 2015). The anti-oxidants are usually added in low concentration (Halliwell and Gutteridge, 1995). Therefore, this study is designed to assess the effective dosage of



butylated hydroxy toluene on the keeping quality of *kulikuli* snack.

## MATERIALS AND METHODS

### Sources of raw materials

Groundnut, onion, salt and pepper (powdered form) were gotten from Minna, Niger State and the anti-oxidant (butylated hydroxy toluene) from Ilorin, Kwara State.

### Production of groundnut snack

Groundnut was manually sorted to remove extraneous materials. Sorted groundnut was then roasted in the laboratory in electric roasting machine at 100°C for 10 min. and allowed to cool at room temperature for 30 min. De-hulling and winnowing were carried out manually to remove the skin. Winnowed dahls were milled in to a paste using an electric grinding machine. To 2.2 kg of the paste, 20.30 g of powdered pepper, 20.30 g salt and 65.3 g onion were added and thoroughly mixed in a laboratory blender. Oil extraction was carried out via wet oil extraction method by adding 400 ml of distilled water, followed by stirring, kneading and pressing the mixture until oil separates. After the oil extraction, the cake was then weighed (2000 g) and divided into 5 equal parts (400 g each). Butylated hydroxy toluene (BHT) (antioxidant) was added to each part at the following concentrations 100 ppm, 150 ppm, 200 ppm, 250 ppm and 300 ppm and properly mixed representing samples A, B, C, D and E respectively. The cake shaping was carried out manually to flat rounded shape. The shaped cakes were then dip-fried in the oil at 130°C for 5 min to harden and make the snacks crunchy. Fried snacks were allowed to cool at room temperature (27 ± 0.2°C) for 10 min and packaged in high density polyethylene sac and kept at room temperature for the duration of the study.

### Methods

#### Free fatty acid

This was determined as described by (AOAC, 2005). Neutral solvent was prepared by adding 190 ml of ethanol to 10 ml of distilled water and 200 ml of ether. 50 ml of neutral solvent was added to 1 g of the sample. Three drops of indicator (1% phenolphthalein) and the mixture was thoroughly shaken and titrated with potassium hydroxide (0.1 N) until pink colour persisted for 15 seconds. Free fatty acid was carried out at intervals of two weeks for two months duration and calculated thus:

$$\text{FFA} = \frac{\text{Titre (ml)} \times 5.61}{\text{Weight of sample used}}$$

Weight of sample used

#### Peroxide value

This was determined as described by AOAC (2005). Acetic acid and chloroform were added together in ratio 2:1 and twenty five (25) ml of the mixture was

added to 1 g of the test sample. One (1) ml of potassium iodide was immediately added to the mixture and kept in a dark place for 10 minutes. After which 30 ml of distilled water and 1 ml of starch were added and then shaken. The mixture was titrated with sodium thiosulphate (0.002 N). The peroxide value was determined at intervals of two weeks for two months. The peroxide value is often reported as number of ml of 0.002 N (M) sodium thiosulphate per g of sample.

#### Saponification value

This was determined as described by AOAC (2005). 1.8 g of NaOH was put into 100 ml of distilled water and 25 ml of the mixture was added to 1 g of the sample. 5 ml of ethanol was added and heated for 1 h. After heating, it was allowed to cool at room temperature and 1 ml of phenolphthalein was added. The mixture was titrated with hydrochloric acid (titration = a ml). Blank was carried out at the same time (titration = b ml). Saponification value determination was done at intervals of two weeks for two months and was calculated thus:

$$\text{Saponification value} = \frac{(b-a) \times 28.05}{\text{Wt. (g) of sample}}$$

#### Sensory evaluation

The sensory evaluation of the snack samples was carried out by 20 untrained panellists from Food Science and Nutrition Department, FUT, Minna. 9 point Hedonic scale with 1- representing extremely like and 9- extremely dislike. The panellists were presented with the coded samples and were asked to judge the samples on the basis of texture and overall acceptability. The assessors were instructed on the basic taste panel procedures. They were equally instructed to take a sip of water and pause for a few seconds before tasting each sample and to re-taste if not sure of their decisions.

#### Statistical analysis

Data obtained were subjected to analysis of variance (ANOVA) using statistical analysis system (SAS) version 9, (2012). Mean were separated using Duncan's multiple range test (DMRT) at 5% level of probability.

## RESULTS AND DISCUSSION

The most important indexes that allow to estimate oxidative stability of finished products are: free fatty acids (FFA) to determine the process of acidification of fatty component, peroxide value (PV) to indicate the degree of primary oxidation and p-Anisidine value (AnV) to evaluate the formation of molecules (aldehydes and ketones) responsible for the organoleptic alterations (Fontanella, 2015). The higher the degree of free fatty acid, the higher the

degree of hydrolytic rancidity and vice versa. The result of this study (Table 1) shows that, samples with higher concentration of BHT showed no variability in free fatty acid values, while sample with the least concentration of BHT (samples A and B) had the highest FFA content throughout the period of this study. This implies that, higher concentration used in this study which is within the safe permitted level in food samples, has the capacity to prevent lipid oxidation.

The peroxide value is used to measure oxidative rancidity of fatty food product. The lower the peroxide value the better the oil content (Ihekoronye and Ngoddy, 1985). Also, it is used as an index of early stage of lipid oxidation. The result of this study (Table 2) shows that different concentration of BHT significantly ( $p \leq 0.05$ ) affects peroxide value of the samples. The peroxide value of the samples decreases as the concentration of BHT increases. The result obtained in this study agrees with the findings of Oladimeji *et al.* (2013) and Azuma *et al.* (1999) who reported that, antioxidative effect of BHT was dependent on concentration. This result implies that, inclusion of BHT in the snack at 250 ppm and 300 ppm per 400g has the potency to control lipid peroxidation.

The saponification value is used to indicate the size of fatty acid chain esterified to glycerol and gives the index of the average length of the fatty acid chain. The result from Table 3 shows that saponification value of the samples decreased as the concentration of BHT increased. During the storage period, samples D and E showed significantly ( $p < 0.05$ ) reduced values, while sample A with 100 ppm BHT per 400g of sample had significantly ( $p < 0.05$ ) high saponification value throughout the seven week duration for this study. However, samples B and C showed mild increase during the storage period.

The sensory attributes (Tables 4 and 5) in terms of texture and general acceptability of the snack samples over seven weeks of storage showed that, the samples were not significantly different from each other throughout the study period. This implies that, different levels of BHT and the storage time had no significant influence on the texture and general acceptability of the snack.

## CONCLUSION AND RECOMMENDATIONS

*Kulikuli* snack with high concentration of BHT (samples D and E) showed significantly low levels of free fatty acid and peroxide values. Therefore, inclusion of BHT in the snack can be done at 250 ppm or 300 ppm per 400 g of the cake prior to frying.

## ACKNOWLEDGEMENTS

The authors are sincerely grateful for the efforts of the Laboratory Technologists, Food Science and Technology Department, Federal University of Technology, Minna, Nigeria and all the authors cited in this study.

Table 1: Free fatty acid (mg/g) groundnut snack treated with butylated hydroxyl toluene over a period of seven week

Week	A	B	C	D	E
1	3.97 <sup>a</sup> ±0.07	3.87 <sup>a</sup> ±0.07	3.43 <sup>b</sup> ±0.07	3.41 <sup>b</sup> ±0.07	3.30 <sup>b</sup> ±0.07
3	4.60 <sup>a</sup> ±0.07	4.50 <sup>a</sup> ±0.07	4.02 <sup>b</sup> ±0.07	3.80 <sup>b</sup> ±0.07	3.50 <sup>b</sup> ±0.07
5	5.08 <sup>a</sup> ±0.03	5.08 <sup>a</sup> ±0.03	4.50 <sup>b</sup> ±0.03	4.02 <sup>b</sup> ±0.03	3.97 <sup>b</sup> ±0.03
7	5.08 <sup>a</sup> ±0.07	5.08 <sup>a</sup> ±0.07	4.70 <sup>b</sup> ±0.07	4.60 <sup>b</sup> ±0.07	4.02 <sup>b</sup> ±0.07

Data are means ± standard error of duplicate determination.

Means with common superscripts in the row are not significantly different at  $p \geq 0.05$ .

Key A = Groundnut snack treated with 100 ppm of BHT; B = Groundnut snack treated with 150 ppm BHT; C = Groundnut snack treated with 200 ppm BHT; D = Groundnut snack treated with 250 ppm BHT; E = Groundnut snack treated with 300 ppm; BHT anti-oxidant; BHT = Butylated hydroxy toluene.

Table 2: Peroxide value (meqO<sub>2</sub>/kg) of groundnut snack stored over seven week period

Week	A	B	C	D	E
1	9.35 <sup>a</sup> ±0.58	8.25 <sup>a</sup> ±0.48	8.00 <sup>ab</sup> ±0.67	7.00 <sup>b</sup> ±0.98	6.75 <sup>b</sup> ±0.38
3	10.40 <sup>a</sup> ±0.81	9.50 <sup>a</sup> ±0.71	8.35 <sup>ab</sup> ±0.81	7.50 <sup>b</sup> ±0.82	6.95 <sup>b</sup> ±0.79
5	3.50 <sup>a</sup> ±0.36	3.35 <sup>a</sup> ±0.36	2.30 <sup>ab</sup> ±0.36	1.60 <sup>b</sup> ±0.36	1.30 <sup>b</sup> ±0.36
7	3.50 <sup>a</sup> ±0.30	3.25 <sup>a</sup> ±0.29	2.00 <sup>ab</sup> ±0.20	1.30 <sup>b</sup> ±0.30	0.75 <sup>b</sup> ±0.31

Data are means ± standard error of duplicate determination.

Means with common superscripts in the row are not significantly different at  $p \geq 0.05$ .

Key A = Groundnut snack treated with 100 ppm of BHT; B = Groundnut snack treated with 150 ppm BHT; C = Groundnut snack treated with 200 ppm BHT; D = Groundnut snack treated with 250 ppm BHT; E = Groundnut snack treated with 300 ppm; BHT anti-oxidant; BHT = Butylated hydroxy toluene.

Table 3: Saponification value of groundnut snack treated with butylated hydroxy toluene taken at week two interval

Week	A	B	C	D	E
1	263.49 <sup>a</sup> ±4.04	234.44 <sup>b</sup> ±5.04	215.46 <sup>c</sup> ±4.94	187.46 <sup>d</sup> ±4.04	128.38 <sup>e</sup> ±4.0
3	275.25 <sup>a</sup> ±10.00	195.93 <sup>b</sup> ±9.98	232.20 <sup>b</sup> ±10.20	148.37 <sup>c</sup> ±11.00	91.36 <sup>e</sup> ±10.00
5	340.32 <sup>a</sup> ±8.43	287.51 <sup>b</sup> ±8.43	238.95 <sup>c</sup> ±8.43	221.95 <sup>c</sup> ±8.43	178.93 <sup>d</sup> ±8.43
7	388.86 <sup>a</sup> ±15.13	279.50 <sup>b</sup> ±15.13	250.97 <sup>b</sup> ±15.13	234.47 <sup>bc</sup> ±15.13	190.95 <sup>c</sup> ±15.13

Data are means ± standard error of duplicate determination.

Means with common superscripts in the row are not significantly different at  $p \geq 0.05$ .

Key A = Groundnut snack treated with 100 ppm of BHT; B = Groundnut snack treated with 150 ppm BHT; C = Groundnut snack treated with 200 ppm BHT; D = Groundnut snack treated with 250 ppm BHT; E = Groundnut snack treated with 300 ppm; BHT anti-oxidant; BHT = Butylated hydroxy toluene.

Table 4: Sensory score for texture from week one to week seven

Week	A	B	C	D	E
1	8.07±0.00	8.17±0.00	8.01±0.04	8.09±0.03	8.07±0.00
2	8.07±0.15	7.97±0.25	8.07±0.15	8.07±0.15	8.07±0.15
3	8.07±0.00	8.07±0.00	8.08±0.00	8.07±0.00	8.08±0.00
4	8.07±0.00	8.07±0.00	8.07±0.00	8.17±0.80	8.07±0.00
5	6.33±0.18	6.13±0.18	6.40±0.18	6.23±0.18	6.40±0.18
6	6.40±0.00	6.50±0.01	6.70±0.00	6.40±0.00	6.40±0.00
7	6.40±0.14	6.40±0.14	6.40±0.14	6.40±0.14	6.40±0.14

Data are means ± standard error of duplicate determination.

Means with common superscripts in the row are not significantly different at  $p \geq 0.05$ .

Key A = Groundnut snack treated with 100 ppm of BHT; B = Groundnut snack treated with 150 ppm BHT; C = Groundnut snack treated with 200 ppm BHT; D = Groundnut snack treated with 250 ppm BHT; E = Groundnut snack treated with 300 ppm; BHT anti-oxidant; BHT = Butylated hydroxy toluene.



Table 5: Sensory score for general acceptability from week one to week seven

Week	A	B	C	D	E
1	7.23±0.10	7.26± 0.00	7.30±0.00	7.03±0.00	7.33±0.00
2	7.93±0.13	7.93±0.13	7.93±0.13	7.93±0.13	7.93±0.13
3	7.83±0.10	7.93±0.00	7.90±0.10	7.93±0.00	7.93±0.00
4	7.93±0.00	7.90±0.10	7.93±0.00	7.92±0.01	7.93±0.00
5	6.53±0.20	6.53±0.20	6.53±0.20	6.53±0.20	6.53±0.20
6	6.53±0.15	6.63±0.25	6.53±0.15	6.77±0.25	6.77±0.25
7	6.07±0.15	6.06±0.13	6.07±0.15	6.07±0.15	6.05±0.13

Data are means ± standard error of duplicate determination.

Means with common superscripts in the row are not significantly different at  $p \geq 0.05$ .

Key A = Groundnut snack treated with 100 ppm of BHT; B = Groundnut snack treated with 150 ppm BHT; C = Groundnut snack treated with 200 ppm BHT; D = Groundnut snack treated with 250 ppm BHT; E = Groundnut snack treated with 300 ppm; BHT anti-oxidant; BHT = Butylated hydroxy toluene.

## REFERENCES

- Adebesin, A. A., Saromi, O. T., Amsusa, N. A. and Fagade, S. O. (2001). Microbiological quality of some groundnut products hawked in Bauchi, a Nigerian City. *Journal of Food Technology in African*, 6(2): 53-55.
- Akano, D. A. and Atanda, O. (1990). Present level of aflatoxin in Nigerian groundnut cake ('kulikuli'). *Letters in Applied Microbiology*, 10(4), 187-189.
- Aletor, O., Ojelabi, A. (2007). Comparative evaluation of the nutritive and functional attributes of some traditional Nigerian snacks and oil seed cakes. *Pakistan Journal of Nutrition*, 6(1): 99-103.
- AOAC (2005). Official Methods of Analysis of the Association of Analytical Chemist. International, 18<sup>th</sup> ed. U.S.A.
- Azuma, K. K., Ippoush, I., Higasio, H. and Terao, J. (1999) "Evaluation of anti-oxidant activities of vegetable extract in linoleic acid emulsion and phospholipids bilayer." *J. Sci Food Agric.*, 79:1-7.
- Damame, S. V., Chavan, J. K. and Toll, S. S.(1990). "Effects of roasting and storage on protein and oil in peanut kernels". *Plant Foods Human Nutr.*, 40: 143 – 148.
- Desai, C. J., Gindhart, J. G., Goldstein, L. S. B. and Zinn, K. (1996). Receptor tyrosine phosphatases are required for motor axon guidance in the Drosophila embryo. 84(4), 599-609.
- Emelike, N. J. T. and Akusu, M. O. (2018). Proximate Composition and Sensory Properties of "Kuli-Kuli" Produced from the Blends of Groundnut and Cashew Kernel. *International Journal of Food Science and Nutrition Engineering* 2018, 8(1): 1-4.
- Fontanella, E. (2015). Shelf life: Informazioni pratiche per arrivare a definire la durabilità di un prodotto e a prolungare la sua vita commerciale. *Camera di Commercio di Torino*, (p. 50). Torino.
- Halliwell, B., and Gutteridge, J. M. C. (1995). The definition and measurement of antioxidants in biological systems. *Free Radical Biol Med.*, 18 :125 -126
- Ihekoronye, A. I. and Ngoddy, P. O. (1985). *Integrated Food Science and Technology for the Tropics*. pp 364, Macmillan Publishers Ltd., London.
- Oladimeji, G. R., Kolapo, A. L. (2008). Evaluation of proximate changes and microbiology of stored defatted residues of some selected Nigerian oil seeds. *African Journal of Agricultural Research*, 3(2): 126-129.

## EFFECT OF STORAGE TEMPERATURE ON SEEDLING GROWTH OF OKRA (*Abelmoschus esculentus* [L.] Moench) CULTIVARS

Joseph\*, E. C., Tolorunse, K. D. and Adama, C. J.

Department of Crop Production, Federal  
University of Technology Minna, Nigeria.

\*Corresponding Authors Email: ethelchinaza.joseph@gmail.com, GSM: 08039251146

### ABSTRACT

The experiment investigated the effects of different storage temperatures (10 °C and 30 °C) on the seedling performance of three cultivars of okra (NHAe47-4, JOKOSO-5 and EX BASAWA 2-5). The experiment was laid out in a completely randomized design, replicated 4 times at the Horticultural Nursery of the Federal University of Technology, Minna. Data for emergence percentage, plant height, number of leaves, fresh weight of shoot biomass (g) and dry weight of shoot biomass (g) were collected at intervals of 0, 2, 4, 6, 8, and 12 weeks after storage (WAS). The results showed that JOKOSO-5 had the highest mean values of 60.35 and 1.78 for emergence percentage and dry weight of shoot biomass (g) respectively, at a storage temperature of 30 °C at 2 WAS. The highest mean values were also recorded for plant height, number of leaves and fresh weight of shoot biomass at 30 °C storage temperature at 10 WAS. Okra cultivars performed better at 30 °C, but seedling performance was influenced by environmental conditions. Storage temperature of 30 °C was therefore recommended for okra seed storage, and further studies can be carried out in controlled environments, to keep environmental conditions in check.

**KEYWORDS:** Storage temperature, Seedling, Okra, Emergence

---

### INTRODUCTION

Okra, (*Abelmoschus esculentus*, (L.) Moench) is one of the major vegetables in tropical and sub-tropical Africa including Nigeria. It is a perennial herbaceous plant treated as an annual plant which belongs to the family Malvaceae and has two main species: *Abelmoschus esculentus* (L.) Moench and *Abelmoschus caillei*. According to (Udoh *et al.*, 2005), okra is generally grown in the tropics particularly tropical Asia, East, Central and west Africa as well as the Caribbean. It is grown for its edible seed pods which are used either, fresh, canned or dried and ground as powder. Njoku and Ebeniro (2009) reported that the tender leaves are often used as vegetable and provide vitamin A and C, protein, calcium and iron. It contains 86 % of water, 2.2 % of protein, 10 % of carbohydrate, 0.2 % of fat and vitamins A, B and C. Fresh okra fruits have also been reported to be rich in vitamins, minerals and plant proteins (Eke, 2008).

Okra thrives in different types of soil. A well drained fertile soil with an adequate content of organic matter and reserves of the major elements are generally

suitable for its cultivation. Some cultivars are sensitive to excessive soil moisture. Others are

slightly tolerant to salt. Optimum pH ranges from 6.6 to 8.0. Most cultivars are adapted to high temperature throughout the growing period with little seasonal fluctuation. Germination occurs mostly in relatively warm soils but is inhibited at temperatures below 16 oC. On a monthly basis, an average temperature range of 21 °C to 30 °C is considered favourable for growth, flowering and development of pods. (Shujat *et al.*, 2006).

The main aim of storage is to prevent seed quality deterioration. This can be done through moisture and air movement control, and also through the prevention of attack by insects, microorganisms, and rodents (Sawant *et al.*, 2012). It is also very essential to maintain seed viability for longer period; this is to preserve the genetic composition in stored samples. Simple techniques have been adopted since very early days to maintain the seed viability in both domesticated and wild sources (Onyekwelua and

Fayose, 2007). Improper storage mediums (Ravi *et al.*, 2014) which include room temperature storage

phenomenon during storage (Schmidt, 2002). Several factors namely temperature, nature of the seeds, seed moisture content, relative humidity and others influence seed longevity during storage periods (Pradhan and Badola, 2008). Seeds obtained during the previous harvest have to be stored for usage in the next season, indeed the storage becomes very important to promote okra production (Anonymous, 2003).

Germination of seed is a function of duration of storage, storage temperature and moisture content at storage (Croft *et al.*, 2012). Therefore, good management of storage temperature and storage duration may enhance germination of the seed and seedling performance (Mubvuma *et al.*, 2013). There is need to evaluate specific storage conditions that are best for favourable germination percentages and seedling performance of okra seeds. The study focuses on the development of threshold storage temperature and storage duration limits which will enable farmers have optimum emergence percentages. Therefore, the objective of this study was to assess the response of okra cultivars to storage temperature and to determine effect of storage temperature on seedling growth of okra.

## METHODOLOGY

The experiment was conducted in the Department of Crop Production Horticultural research nursery, Federal University of Technology, Minna, (9°40'N and 6°3'E) in the Southern Guinea Savannah of Nigeria. The seeds of okra cultivars; NHAe 7-4, JOKOSO-5 and EX BASAWA 2-5 were sourced from the Institute for Agricultural Research (IAR), Zaria. Seeds of three cultivars were packaged in rubber-stoppered glass bottles which were further secured with candle wax to maintain moisture content (Tatipata, 2009); the bottles with seeds were stored at 10 °C and 30 °C for 16 weeks. Emergence was tested at 0, 2, 4, 6, 8, 10, and 12 weeks after storage (WAS).

The experiment was laid out in Completely randomized design with four replications. Data were collected on emergence percentage, plant height, number of leaves, fresh weight of shoot biomass and dry weight of shoot biomass.

often results in low seed germination, seed deterioration and loss of viability which are natural

**Data Analysis:** The data collected on all the parameters were subjected to analysis of variance (ANOVA) using Statistical Analysis Software (SAS) and where significant differences among treatments were obtained; means were separated using least Significant difference (LSD). All data in percentage were first converted to arcsin values before statistical analysis was conducted.

## RESULTS AND DISCUSSION

The result indicated that there were no significant differences ( $p < 0.05$ ) in storage temperature for emergence percentage except at 6 WAS with a higher emergence percentage of 39.28 % at 30 °C (Table 1). Also, emergence percentage for cultivar was not significant except at 6, 8 and 12 WAS, with JOKOSO-5 recording a higher value (67.17) at 12

WAS. The interaction effect was only significant at 2 WAS as shown in Table 1 and 2, with JOKOSO-5 having the highest emergence percentage at 30 °C. Tables 3 and 4 show no significant difference

( $p < 0.05$ ) in storage temperature for fresh and dry weights for shoot biomass (g) at 10 °C and 30 °C for all the weeks of storage, while there was significant difference ( $p > 0.05$ ) in cultivar at 4, 8, & 10 and 4, 8, 10, & 12 WAS for fresh and dry shoot biomass respectively. EX BASAWA2-5 had the highest weights of 43.11 g and 5.76 g respectively at 10 WAS. The interaction effect was only significant for dry weight of shoot biomass at 2 WAS (Table2), with

JOKOSO-5 having the highest dry weight of shoot biomass at 30 °C.

Table 5 shows that the plant height at both storage temperatures was not significant ( $p < 0.05$ ) for all the weeks of storage, but 30 °C had the highest plant height of 25.74 cm at 10 WAS. But there was significant difference ( $p > 0.05$ ) in cultivar for all the weeks of storage with EX BASAWA 2-5 having the highest plant height (29.71cm) at 10 WAS. The interaction effect was not significant. Table 6 also shows a similar trend for number of leaves, with no significant difference ( $p < 0.05$ ) at both 10 °C and 30 °C, for all the weeks of storage, but 30 °C had the highest number of leaves (9) at 10WAS, however,



there was significant difference ( $p>0.05$ ) in plant height for cultivar at 4 and 8 WAS. EX BASAWA 25 had a higher number of leaves (9) at 10 WAS. The interaction effect was not significant.

seeds against potential fungal pathogens, in which seeds stored in cotton bag at 28 °C recorded significant germination percentage. This can be attributed to the fact that the moisture content was kept constant through the use of glass bottles for packaging which was further sealed with candle wax.

The study revealed that there was a higher emergence percentage at a storage temperature of 30 °C. This agrees with the findings of Mashooda *et al.*, (2005), who evaluated certain storage conditions for okra

Table 1: Effect of storage temperatures on the emergence percentage of okra cultivars

Treatment	Storage Time (Weeks After Storage)						
	0	2	4	6	8	10	12
<b>Storage Temperature (T)</b>							
10 °C	53.99 <sup>a</sup>	56.11 <sup>a</sup>	48.23 <sup>a</sup>	30.91 <sup>b</sup>	43.97 <sup>a</sup>	56.12 <sup>a</sup>	63.27 <sup>a</sup>
30 °C	55.87 <sup>a</sup>	54.01 <sup>a</sup>	51.81 <sup>a</sup>	39.28 <sup>a</sup>	49.29 <sup>a</sup>	60.81 <sup>a</sup>	62.45 <sup>a</sup>
SE±	2.3	2.1	2.1	3.0	3.2	1.8	2.0
<b>Cultivar (C)</b>							
NHAe 47-4	54.63 <sup>a</sup>	55.90 <sup>a</sup>	48.51 <sup>a</sup>	34.37 <sup>ab</sup>	36.46 <sup>b</sup>	56.09 <sup>a</sup>	59.14 <sup>b</sup>
JOKOSO-5	56.19 <sup>a</sup>	56.41 <sup>a</sup>	54.37 <sup>a</sup>	42.03 <sup>a</sup>	54.57 <sup>a</sup>	60.69 <sup>a</sup>	67.17 <sup>a</sup>
EX BASAWA 2-5	53.97 <sup>a</sup>	52.88 <sup>a</sup>	47.17 <sup>a</sup>	28.88 <sup>b</sup>	48.86 <sup>a</sup>	58.61 <sup>a</sup>	62.27 <sup>ab</sup>
SE±	2.9	2.6	2.3	3.5	3.0	2.3	2.1
<b>Interaction</b>							
T*C	NS	*	NS	NS	NS	NS	NS

Means followed by the same letter(s) within a row do not differ significantly at  $p \leq 0.05$  by Least Significant Difference

Table 2: Interaction effect of storage temperatures and cultivar on emergence percentage of okra at 2 weeks after storage

Cultivar	Temperature	Wet biomass	Dry biomass
NHAe 47-4	10 °C	51.45 <sup>ab</sup>	0.97 <sup>b</sup>
	30 °C	60.17 <sup>a</sup>	1.58 <sup>ab</sup>
JOKOSO-5	10 °C	56.72 <sup>ab</sup>	1.46 <sup>ab</sup>
	30 °C	60.35 <sup>a</sup>	1.78 <sup>a</sup>
EX BASAWA 2-5	10 °C	52.65 <sup>ab</sup>	1.17 <sup>ab</sup>
	30 °C	49.05 <sup>b</sup>	1.21 <sup>ab</sup>
			0.19
			SE±
			3.04

Means followed by the same letter(s) within a row do not differ significantly at  $p \leq 0.05$  by Least Significant Difference

Table 3: Effect of storage temperatures on the fresh weight (g) of shoot biomass of okra cultivars at 4 weeks after sowing

Treatment	Storage Time (Weeks After Storage)						
	0	2	4	6	8	10	12
<b>Storage Temperature (T)</b>							
10 °C	10.05 <sup>a</sup>	6.41 <sup>a</sup>	6.88 <sup>a</sup>	6.70 <sup>a</sup>	10.66 <sup>a</sup>	32.58 <sup>a</sup>	11.49 <sup>a</sup>
30 °C	9.15 <sup>a</sup>	7.28 <sup>a</sup>	7.71 <sup>a</sup>	5.26 <sup>a</sup>	15.05 <sup>a</sup>	40.02 <sup>a</sup>	12.35 <sup>a</sup>
	0.80	0.79	1.42	1.69	3.29	3.48	0.66
<b>SE±</b>							
<b>Cultivar ( C )</b>							
NHAe 47-4	9.20 <sup>a</sup>	7.18 <sup>a</sup>	7.17 <sup>ab</sup>	3.40 <sup>a</sup>	3.78 <sup>b</sup>	28.06 <sup>b</sup>	10.91 <sup>a</sup>
JOKOSO-5	10.36 <sup>a</sup>	6.98 <sup>a</sup>	4.23 <sup>b</sup>	9.15 <sup>a</sup>	10.89 <sup>b</sup>	37.73 <sup>ab</sup>	11.70 <sup>a</sup>
EX BASAWA 2-5	9.24 <sup>a</sup>	6.38 <sup>a</sup>	10.49 <sup>a</sup>	5.38 <sup>a</sup>	23.89 <sup>a</sup>	43.11 <sup>a</sup>	13.06 <sup>a</sup>
	0.93	0.92	1.45	1.69	2.63	3.99	0.72
<b>Interaction</b>							
T*C	NS	NS	NS	NS	NS	NS	NS

Means followed by the same letter(s) within a row do not differ significantly at  $p \leq 0.05$  by Least Significant Difference

Table 4: Effect of storage temperatures on the dry weight (g) of shoot biomass of okra cultivars at 4 weeks after sowing

Treatment	Storage Time (Weeks After Storage)						
	0	2	4	6	8	10	12
<b>Storage Temperature (T)</b>							
10 °C	1.35 <sup>a</sup>	1.34 <sup>a</sup>	1.41 <sup>a</sup>	0.96 <sup>a</sup>	1.72 <sup>a</sup>	4.12 <sup>a</sup>	1.62 <sup>a</sup>
30 °C	1.35 <sup>a</sup>	1.39 <sup>a</sup>	1.50 <sup>a</sup>	0.82 <sup>a</sup>	2.51 <sup>a</sup>	5.16 <sup>a</sup>	1.73 <sup>a</sup>
SE±	0.09	0.14	0.24	0.23	0.53	0.49	0.11
<b>Cultivar ( C )</b>							
NHAe 47-4	1.25 <sup>a</sup>	1.37 <sup>a</sup>	1.28 <sup>b</sup>	0.55 <sup>a</sup>	0.64 <sup>b</sup>	3.14 <sup>b</sup>	1.41 <sup>b</sup>
JOKOSO-5	1.47 <sup>a</sup>	1.38 <sup>a</sup>	1.02 <sup>b</sup>	1.36 <sup>a</sup>	1.84 <sup>b</sup>	5.02 <sup>a</sup>	1.77 <sup>a</sup>
EX BASAWA 2-5	1.32 <sup>a</sup>	1.33 <sup>a</sup>	2.07 <sup>a</sup>	0.76 <sup>a</sup>	3.86 <sup>a</sup>	5.76 <sup>a</sup>	1.84 <sup>a</sup>
SE±	0.09	0.16	0.24	0.22	0.43	0.50	0.11
<b>Interaction</b>							
T*C	NS	*	NS	NS	NS	NS	NS

Means followed by the dissimilar letter(s) within a row differ significantly at  $p \leq 0.05$  by Least Significant Difference



Table 5: Effect of storage temperatures on the plant height of okra cultivars at 4 weeks after sowing

Treatment	Storage Time (Weeks After Storage)						
	0	2	4	6	8	10	12
<b>Storage Temperature (T)</b>							
10 °C	7.41 <sup>a</sup>	7.9 <sup>a</sup>	8.27 <sup>a</sup>	7.9 <sup>a</sup>	12.60 <sup>a</sup>	23.15 <sup>a</sup>	15.7 <sup>a</sup>
30 °C	7.12 <sup>a</sup>	7.76 <sup>a</sup>	9.14 <sup>a</sup>	7.96 <sup>a</sup>	16.82 <sup>a</sup>	25.74 <sup>a</sup>	16.36 <sup>a</sup>
SE±	0.30	0.48	0.62	0.90	2.41	1.80	1.00
<b>Cultivar ( C )</b>							
NHAe 47-4	6.11 <sup>b</sup>	7.39 <sup>b</sup>	6.70 <sup>b</sup>	6.61 <sup>b</sup>	6.67 <sup>c</sup>	17.11 <sup>b</sup>	12.10 <sup>b</sup>
JOKOSO-5	7.97 <sup>a</sup>	7.81 <sup>ab</sup>	9.08 <sup>a</sup>	10.02 <sup>a</sup>	14.96 <sup>b</sup>	26.53 <sup>a</sup>	18.31 <sup>a</sup>
EX BASAWA 2-5	7.71 <sup>a</sup>	8.31 <sup>a</sup>	10.34 <sup>a</sup>	7.16 <sup>ab</sup>	22.49 <sup>a</sup>	29.71 <sup>a</sup>	17.73 <sup>a</sup>
SE±	0.91	0.56	0.55	0.91	1.89	1.14	0.60
<b>Interaction</b>							
T*C	NS	NS	NS	NS	NS	NS	NS

Means followed by the dissimilar letter(s) within a row differ significantly at  $p \leq 0.05$  by Least Significant Difference

Table 144: Effect of storage temperature

Treatment	Storage Time (Weeks Afer Storage)						
	0	2	4	6	8	10	12
<b>Storage Temperature (T)</b>							
10 °C	7.00 <sup>a</sup>	6.75 <sup>a</sup>	6.83 <sup>a</sup>	5.83 <sup>a</sup>	6.25 <sup>a</sup>	8.33 <sup>a</sup>	6.25 <sup>a</sup>
30 °C	6.75 <sup>a</sup>	6.50 <sup>a</sup>	6.42 <sup>a</sup>	6.17 <sup>a</sup>	6.75 <sup>a</sup>	8.50 <sup>a</sup>	6.25 <sup>a</sup>
SE±	0.26	0.25	0.44	0.49	0.62	0.31	0.2
<b>Cultivar ( C )</b>							
NHAe 47-4	6.88 <sup>a</sup>	6.50 <sup>a</sup>	6.50 <sup>ab</sup>	5.63 <sup>a</sup>	4.75 <sup>b</sup>	8.75 <sup>a</sup>	6.50 <sup>a</sup>
JOKOSO-5	7.00 <sup>a</sup>	6.63 <sup>a</sup>	5.88 <sup>b</sup>	6.75 <sup>a</sup>	6.63 <sup>ab</sup>	8.13 <sup>a</sup>	6.25 <sup>a</sup>
EX BASAWA 2-5	6.75 <sup>a</sup>	6.75 <sup>a</sup>	7.50 <sup>a</sup>	5.63 <sup>a</sup>	8.13 <sup>a</sup>	8.38 <sup>a</sup>	6.00 <sup>a</sup>
SE±	0.30	0.31	0.47	0.56	0.58	0.36	0.23
<b>Interaction</b>							
T*C	NS	NS	NS	NS	NS	NS	NS

Means followed by the dissimilar letter(s) within a row differ significantly at  $p \leq 0.05$  by Least Significant Difference

## REFERENCES

- Adejoye, O., Awokoya, J. O., and Emmanuel, O. E. (2009). Effect of seasonal changes on Growth and Yield of Okra (*Abelmoschus esculentus* [L] Moench). *Research Journal of Agriculture & Biological Sciences*; Vol. 5 Issue 6 , p. 940.
- Anonymous, (2003). Indian Agriculture. Vikas Singhal for Indian Economic Data Research Centre, Maya Pur. New Delhi, India.
- Croft M., Bickster A., Manson, J. and Burnette (2012). Vacuum Sealing vs Refrigeration: Which is the most effective way to store seeds? Echo Asia notes. A Regional Supplement to Echo Development notes. Issue 14, 2012.
- Doijode, S. D. (2001). Okra : *Abelmoschus esculentus* (L.) Moench. . Seed storage of horticultural crops. New York: Food products Press- an imprint of Haworth Press, Inc. (pp. pp. 181-189).
- Eke, K. A. (2008). Determination of Optimum Planting Time of Okra. *Proceedings of the 42nd Annual Conference of Agricultural Society of Nigeria (ASN). October 19th to 23rd at Ebonyi State University., Ebonyi.* (pp. 242-245.).
- Mashooda B, S. Lokesh, R. V. Ravishankar, M. D. Shailaja, T. V. Kumar and H. S. Shetty. (2005). Evaluation of certain storage conditions for okra (*Abelmoschus esculentus* [L] Moench) Seeds against potential fungal pathogens. *International Journal of Agriculture & Biological, Vol. 7, No. 4* , 550-554.
- Mubvuma, M., Mapanda, S., and Mashonjowa, E. (2013). Effect of storage temperature and duration on germination of moringa seeds (*Moringa oleifera*). *Greener Journal of Agricultural Sciences. Vol 3(5)* , pp. 427-437.
- Njoku, S. C., and Ebeniro, N. (2009). Varietal Performance of Okra on a Heplic Aersoil in Abia State. Pp 52 –55.
- Onyekwelua, J., and Fayose, O. J. (2007). Effect of storage methods on the germination and proximate composition of *Treculia africana* seeds. In: *Proceedings of the International Conference on Agricultural Research for Development.* University of KasselWitzenhausen and University of Gottingen, Topentry.
- Pradhan, B. K., and Badola, H. K. (2008). Seed germination response of populations of *Swertia chirayita* following periodical storage. *Seed Technology*; 30(1), 63-69.
- Ravi, B., Meenu, S., and Usha, T. (2014). Effect of storage temperature and period on seed germination of *Rheum austale* D Don: an endangered medicinal herb of high altitude Himalaya. *International Journal of Farm Sciences* , 139-147.
- Schmidt, L. (2002). Guide to handling of tropical and subtropical forest seeds. Denmark: Borch Tyrk A/S (Dandia Forest Seed Centre).
- Sawant, A.A., S.C. Patil, S.B. Kalse, and N.J. Thakor. (2012). Effect of temperature, relative humidity and moisture content on germination percentage of wheat stored in different storage structures. *Agricultural Engineering International Journal, 14(2)* , 110-118.
- Shujat, H., Sajid, M., Amin, N.-u., Nam, S., and Iqbal, Z. (2006). Response of okra (*Abelmoschus esculentus*) cultivars to different sowing times. *Journal of Agricultural and Biological Science* , 55-59.
- Tatipata, A. (2009). Effect of seed moisture content, packaging and storage period on mitochondria inner membrane of soybean seed. *Journal of Agricultural Technology* 5(1): 51-64.
- Udoh, D. J., Ndon, B. A., Asuquo, P. E., and Ndaeyo, N. U. (2005). Crop Production Techniques for the Tropics. 223 – 247.



**RELATIONSHIP BETWEEN WATER VOLUMES, SHAPES, GLASS THICKNESSES AND WATER HOLDING CAPACITY OF 40 LITRES GLASS AQUARIA**

Olayimika, S. O. A\*, Lamai, S. L\*\*, Olugboji, O. A\*\*\* and Garkida, A. D.\*\*\*\*

\*Corresponding author [solo.olayimika@futminna.edu.ng](mailto:solo.olayimika@futminna.edu.ng) | [seideolayimika@gmail.com](mailto:seideolayimika@gmail.com),

[horseford2000@yahoo.com](mailto:horseford2000@yahoo.com) +(234)-08060361100, 08055531823

Water

Resources, Aquaculture and Fisheries Technology Department,

Federal University of Technology, Minna; Niger State,

\*\*Water Resources, Aquaculture and Fisheries Technology Department,

Federal University of Technology, Minna; Niger State

\*\*\* Mechanical Engineering, Federal University of Technology, Minna; Niger State, Department;

\*\*\*\* Glass Technology Department, Ahmadu Bello University, Zaria; Kaduna State. Corresponding

author

**ABSTRACT**

*The study determines the relationship between water volumes, glass thickness, and water holding capacity of three shapes of 40 Litres (L) glass aquaria. Glass aquaria were designed and constructed using 3 mm, 4 mm and 5 mm thicknesses glass for Tower, Prism and Cuboid shapes in triplicate and they were tested for leakages. Water was introduced into each aquarium and monitored under room condition for 49 days. A significant difference occurred ( $p < 0.05$ ) in the volume of water that can be retained by Prism shaped and 3 mm glass thickness of glass aquaria. Prism shaped 3 mm thickness glass aquaria failed in retention of water of 40 L with a significant difference ( $p < 0.05$ ) within the shape for various glass thicknesses and between the shapes for various glass thicknesses. Tower and Cuboid shaped aquaria retained water, without significant difference ( $p > 0.05$ ) within and between the shapes. 4 mm and 5 mm glass thicknesses retained water without significant difference ( $p > 0.05$ ) within and between them for all the shapes. 4 mm and 5 mm glass thicknesses are recommended for the construction of Prism, Tower and Cuboid shaped 40 L aquaria, while 3 mm can be used for Tower and Cuboid shaped aquaria for economic reason. Aquaria builders have opportunity to offer quality aquaria to customers based on their demand using 4 mm and 5 mm glass thicknesses for 40 L Prism, Tower and Cuboid shaped glass aquaria. Opportunity for choice of glass thicknesses based on customers' financial ability exist between 4 mm and 5 mm for Prism, Tower and Cuboid shaped glass aquaria, minimizing loss of time, money, power and materials caused by failure and increase in healthy nation, job creation and wealth for the people are attainable based on this research outcome.*

Key words: Aquarium, Glass thicknesses, Shapes, Water volumes and Water holding capacity

**Introduction:**

Ornamental fisheries are evolving aspect of fisheries called recreational fisheries in some instances. It is the study and production of special featured aquatic animal and plant (colour, shapes, movement, emission and activity), housing, marketing and managing them and their environment for aesthetic, recreational and healing purpose. Ornamental fish is a shellfish or finfish that attracts more value per unit weight than other aquatic animals of the same physical size as a result of its special feature(s) possessed for aesthetic purposes (beautification and endearment), recreation and health implication (natural therapy), it is regarded as the most valuable fish. It is generally smaller in size compared to table fishes except sport fishes (Olayimika, 2001). They are classified into salt and freshwater ornamental fishes. Ornamental fishes are mostly kept alive in an enclosure, those in aquarium are therefore referred to as aquarium fishes, while the sport fishes are mostly

kept in the ponds, pools, lakes, streams, dams, reservoirs and recreational centres (Olayimika and Lamai, 2008, 2010). Livengood and Chapman (2017) said "Ornamental fish is often used as a generic term to describe aquatic animals kept in aquarium hobby, including fishes, invertebrates such as corals, crustaceans (examples, crabs, helmit crabs, shrimps), mollusks (snails, clams, scallops), and also live rock".

Ornamental fisheries are of great importance to human race, it is used for the following among others: Aesthetic purposes (beautification and endearment) of homes, offices and other places; Recreational purposes (relaxation, picnic and tourism centres for people), Health purpose (prevent and control sicknesses caused by stress and brain fatigue such as Stroke, Hypertension), Minimize vices in the society and family (where young people will have

opportunity to spend their time in viewing rather than being engaged in evil things), Job and wealth creation for aquarium producers, fish breeders, marketers, foreign exchange for nations, Research and learning at various levels.

Ornamental fish culture is fast becoming a major branch of aquaculture worldwide. Aquarium has tremendous economic opportunities and prospects which is leading to the recognitions it is gaining very fast (ornamental fish and aquatic plant industry). The world ornamental fish trade is around US\$6 billion (Fossa, 2004). Ornamental fish export trade has been carried out in Nigeria for over 40 years (Areola, 2004). It was started by some Americans who invested heavily into the identification and location of these species in water bodies and still send in request till date. The export trade is growing in Nigeria, earning over \$1.5 million with about 100 identified species (Areola, 2004, Koroye, 2010, Ukaonu *et.al.*, 2011). Ecotourism includes fisheries for other areas of human satisfaction apart from consumption (Fadipe, 2007, Yusuf and Ogundana, 2016), but the sector has long been neglected, probably due to lack of awareness of its large potentials (Chukwura, 2008). Yusuf and Ogundana (2016) said “Ornamental fishery production has not been fully taken into consideration due to some reasons which includes: lack of awareness about the possible use of ornamental fishes as an element of attraction, lack of technicalities in the area of culturing ornamental fishes, paucity of information on available source of ornamental fishes, and non interest of private individuals in breaking a truce in the area of making ornamental fishes an element of tourist attractions” The hobby of keeping fish has been adopted by man in order to appreciate the grace and beauty of one of nature’s creatures (Odunaiya, 1986).

Ornamental fishes are kept at homes and offices in small compartments in most of the cases as an artificial home for viewing and recreational purposes, aquaria are mostly used for these. Thus, it is an enclosure that is made to house aquatic organisms with at least a transparent side for viewing. The transparent side(s) is mostly made of glass; other useable materials are Acrylic and Perplex. There are various types of glass, they include Annealed, Tempered or Toughened, Laminated, Heat strengthened and Reflective. Annealed glass is the cheapest, most common and most used of all the

glasses in aquarium construction. Aquascaping (designing of aquarium) is exciting and is a major challenging part of the fish (ornamental) keeping hobby. The Ornamental fishes are usually kept in aquaria in homes for beautification and in public aquaria devoted primarily to the scientific study of plants and animals and they are usually made to stimulate the natural environment (Poluvin, 1996). Aquarium is a mini copy of the natural habitat of the fish, therefore care must be taken in designing, preparing and maintaining the aquarium's elements and ecosystem. Aquarium mostly serves as home in which ornamental fishes and other organisms are kept healthy, while sport fishes are kept in larger compartment in most cases.

Aquaria of various volumes and shapes are being designed to meet aesthetic demand of customers, to provide conducive environment for organisms that inhabit it and keeping water intact within it (Paranjayap, *et. al.* 2014). Aquarium design entails conceiving and visualizing a concept, sketching it and developing the sketch, putting into consideration the organisms to be kept in it, the location it will be placed, the management that will be involved and interest of the consumer. The wall of the aquaria (size, shape and thickness) may affect its ability to function. Aquaria walls have to function as the air, water and weather barriers, that is designed to withstand the structural stresses imposed on it and its performance at room temperature, looking attractive to the customer and provide good environment (water) in which aquatic organisms survive. Glass is a material used for aquarium, it is brittle and with sudden failure structurally, which is dangerous. The theoretical strength of glass is very high tensionally and compressively, because of surface and edge flaws in the glass sheet this strength is not achieved in practice.

#### The Glass Physical Characteristics

Density:	approx. 2.5 at 21°C
----------	---------------------



Coefficient of linear expansion:	$86 \times 10^{-7} \text{m}^{\circ}\text{C}$
Softening Point:	730°C
Modulus of Elasticity:	69GPa (69 x 10 <sup>9</sup> Pa)
Poisson's ratio:	Float Glass 0.22 to 0.23
Compressive Strength:	25mm Cube: 248MPa (248 x 10 <sup>6</sup> Pa)
Tensile Strength:	19.3 to 28.4MPa for sustained loading
Tensile Strength (toughened glass):	175MPa.

Glass has a much lower coefficient of linear expansion than most metals (Warren,2001)

People of diverse income, social status and concept demand for various shapes and sizes of aquaria to meet their need (aesthetic, healing). The quality and cost implication of procuring such have been a major challenge due to failure experienced based on strength of glass. Most aquaria builders make use of 4 mm thick glass for construction of home and office aquaria without adequate information on the thickness capacity of such glass and the role that may be played by the shape and size of aquarium under consideration. Financial losses due to properties, fish and equipment damage as a result of cracks and breakages have been a major problem facing aquarium producers and customers, especially in under developed and developing nations. The time required to put things in place and odor from wet rugs in many homes have also been discouraging. This is as a result of annealed glasses of mostly 3 mm and 4 mm commonly found in the market and mostly used by aquarist in construction of aquaria irrespective of shape and sizes. Ornamental fish is demanded everywhere in the world (Fossa, 2004, Ploeg, 2017). The suitability of various thicknesses of glass required for construction of various shapes of aquaria will be derived. However, the constraint of scientific application in design and construction has been a major challenge which this study addressed.

#### Materials and Methods:

Three replicates of each shape were used under room condition with each replicate in separate room for each design. Sketch of the designs (Tower, Prism and Cuboid) were drawn to scale using bisector, protractor, angles, ruler, pencil, paper and eraser. Glass sheets were procured and packed in cases (to prevent cracks and breakages), then transported to the project site, while hand gloves were worn for protection and glass sheets were cut into required sizes for construction using glass cutter to cut from intersection points with the aid of long ruler after measurement with measuring tape and accuracy confirmed using angle on the absorbent workshop table. Edges of the cut glass were dulled with dulling stone and hand towel used in cleaning the glass from

particles. Sealant, Silicon Gun, Plump, Solvent, The sealant nozzle tip was cut slanting at 45 ° with an opening of 4-5 mm and the sealant's tip was cut, then the nozzle screwed to it and fixed into the sealant gun and triggered for 4-5 mm overflow. Assembling of each shape was done according to the specification. Cello-tape were cut to 10-15 cm and attached externally in pairs to all sides of the basement glass sheet, likewise a set of opposite sides to serve as a means of attachment for form work formation while the glass sheets were located beside their potential position. Each of the side glass sheets were lifted- up and placed in its rightful position using the cello-tape to brace until all the sides were erected and positioned in its form. The aquaria were cured under room condition. The first curing took 30 - 60 minutes after construction, after which the aquarium was relocated from the workshop table for a pre-test, where water of 1-2 litres was used to test for leakages along the joints. A further cure that took a total of 24 hours was done before the aquaria were fully test for leakages. Water was introduced into each aquarium gradually to determine the water holding capacity for different shapes and observed for forty nine days.

#### Results and Discussion

The experiment was conducted under average room temperature of 23.9 °C (22 – 27.5 °C) and average water temperature of 18.6 °C (16 – 21.5 °C). Three millimeter (mm) glass thicknesses failed to retain 40 litres of water in Prism shaped aquarium ( $29.67 \pm 1.48$ ) with a significant difference ( $p < 0.05$ ) within and between the shapes. 4 mm and 5 mm glass thicknesses retained water in Prism, Tower and Cuboid shaped aquaria without a significant difference ( $p > 0.05$ ) and 3 mm in Tower and Cuboid shaped aquaria without a significant difference ( $p > 0.05$ ). This shows that glasses of higher thicknesses are with better ability to retain water, this agrees with Aquarium Fish Tank, (2015) that with enough braces, an enormous glass tank can be constructed from very thin material theoretically, but looks unattractive because of vertical braces within few centimeters and undesirable. In order to achieve a reasonable seeing area, there is need to consider thickness and material's type for the work. Failure occurred in 3 mm glass thicknesses in Prism shaped aquaria during



and shortly after filling with water, 3 mm glass thickness is significant different ( $p < 0.05$ ) from 4 mm and 5 mm glass thicknesses. No failure occurred in 3 mm, 4 mm and 5 mm glass thicknesses in Tower and Cuboid shaped glass aquaria ( $p > 0.05$ ). Significant difference ( $p < 0.05$ ) occurred between Prism and other shapes (Tower and Cuboid) only in 3 mm glass thickness. The Shape of the Aquaria affect its ability to retain water, shape with the highest water column (depth) and only three bond sides had less ability to retain water of equal volumes, thus confirmed Aquarium Fish Tank (2015) concept that the choice of the right glass is critical in such applications because, it is a brittle material and is weak in tension due to its non-crystalline molecular structure and Warren (2001) that glass has a much lower coefficient of linear expansion than most metals. **Failures occurred because it has only ability to bend a little before failure, this is in consonance with** Morgan (2010) that glass is a totally brittle substance. It will bend a very small amount, but has no capacity like most metals to deform. It will bend to a point and then break.

Table 1: Relationship between Water volumes, Glass thicknesses and Shapes and Water holding capacity of 40 Litres Glass Aquaria

Thicknesses →	3 mm	4 mm	5 mm
Shapes ↓			
Prism	29.67±1.48 <sup>a</sup>	No failure <sup>b</sup>	No failure <sup>b</sup>
Tower	No failure <sup>b</sup>	No failure <sup>b</sup>	No failure <sup>b</sup>
Cuboid	No failure <sup>b</sup>	No failure <sup>b</sup>	No failure <sup>b</sup>

P < 0.05

Volumes in Litres

Aquaria builders have opportunity to offer quality aquaria to customers based on their demand using 4 mm and 5 mm glass thicknesses for 40 L Prism, Tower and Cuboid shaped glass aquaria and 3 mm for Tower and Cuboid shaped aquaria based on their financial ability and aesthetic demand of the customers. Thus, this research will help to eliminate losses of time, energy, money and materials that would have be caused by aquarium glass failure. This will

help in building a healthy people that will be more productive, job and wealth creation for the people are attainable based on this research outcome.

### Conclusion and Recommendation

Aquaria of fourty (40) litres water holding capacity of Tower and Cuboid shapes can be design and constructed using 3 mm, 4 mm and 5 mm glass thicknesses, while 3 mm cannot be used for Prism shaped of the said capacity. Further researches should be carried out on other glass thicknesses, shapes and volumes.

### REFERENCES

- Areola, F. O. (2004). Export potential of ornamental live fish in Nigeria. *Fisheries Society Conference Proceedings*, Calabar p.589
- Aquarium Fish Tank (2015). Retrieved from Build aquarium: <http://www.info.com>
- Chukwura, D. I. (2008). Ornamental fish industry, scope and project for future development in Nigeria, Newsletter of the Federal College of Fisheries and Marine Technology, Victoria Island, Lagos
- Fadipe, A. S. (2007). *Basic principles and practice of tourism media*, ACE, Lagos
- Froese, R and Pauly D, (2015). *Fish base* Retrieved from <http://www.fishbase.org/search.php>
- Fishlore Aquarium Fish information (2015). *Footprint of tank*, Retrieved from <http://www.fishlore.com>
- Fossa, S.A. (2004). Man-made fish: Domesticated fishes and their place in aquatic trade and hobby. *Ornamental Fish International Journal*, 44, 1-23
- Koroye, E. (2010). *Export ornamental fish is big business*, African Aquaculture and Fisheries Digest 3 (8) 11
- Livengood, E. J. and Chapman, F. A. (20017). *The ornamental fish trade: An introduction with perspectives for responsible aquarium fish ownership*. UF/FAS Extention, University of Florida Retrieved from <http://edis.ifas.uft.edu>. October, 2017
- Morgan, T. (2010). *Aspect of Structural Glass*. Institute of Structural Engineers, SE Counties ranch 1-81
- Odunaiya, O. (1986). Investment Opportunity in Aquarium Technology - Export Marketing of Tropical Aquarium Fishes *Proceedings of the 5<sup>th</sup> Annual Conference of Fisheries Society of Nigeria* held at Ilorin, 261-269
- Olayimika, S.O (2001). Appraisal on the survival of the *Poecilia reticulata* (Guppy) as an ornamental fish in the Northern Nigeria (A case study of Minna, Niger State). A Master's degree thesis submitted to

Postgraduate School, Federal University of Technology, Minna, Niger State; Nigeria.

*Recreational Industry* 14 (1) 1-5. Retrieved from [www.transcampus.org/journal](http://www.transcampus.org/journal); [www.ajol.info/journal/jorind](http://www.ajol.info/journal/jorind)

Olayimika, S.O (2008). Appraisal on the survival of the *Xiphophorus maculatus* (Platy) as an ornamental fish in the Northern Nigeria (A case study of Minna, Niger State). *Proceedings of Annual Conference of International Research and Development Institute, Research and Development Network* held June 24-27, 2008 at Institute for Development Research Hall, Ahmadu Bello University, Zaria, Nigeria 3:8; 121

Olayimika, S. O. (2009). Effect of sex combination ratio on breeding of *Poecilia reticulata* (Guppy) for ornamental purpose. *Proceeding of Annual Conference of International Research and Development Institute* held at University of Porthacourt, September 2-3, 2009, 5: 5; 48-51

Olayimika, S. O. and Lamai, S. L. (2010). Effect of parental sex and breed on phenotypical expression (colouration) in progeny of *Peocilia reticulata* (Guppy) for Ornamental Purpose. *Journal of Applied Agricultural Research* 2:1;127-132

Paranjayap, P., Martyn, P., Maluniu, O., Lettyb, B. (2014). [How to make an aquarium](http://www.glassfiles.com). Retrieved from <http://www.glassfiles.com>.

Ploeg, A. (2017). The Indian ornamental fish industry. *Ornamental Fish International*. Retrieved from <http://www.ofish.org>

Poluvin, N. V. C. (1996). Reef fisheries. Chapman and Hall, London 7-47 adapted from Onuoha, P. C. (2008). A Preliminary Survey of Marine Ornamental Fishes in the Catches of Fishing Trawlers Operating Within the Nigerian Continental Shelf. *International Journal of Emerging Technology and Advance Engineering*. 4 (9) 2250-2459, September 2014) p.1 Retrieved from [www.ijetae.com](http://www.ijetae.com)

Umarani, G., Premalatha, E. and Aruna, M.T.P. (2010). Facades of Tall Buildings-State of Art, *Modern Applied Science, Canadian Center of Science and Education* 4, 12. Retrieved from <http://www.ccsenet.org/mas>

Yusuf, O. I. S and Ogundana, F. O. (2016). Ornamental Fish Tourism and Economic Development, *Journal of Ornamental and*



# AGRICULTURAL DIVERSIFICATION FOR FOOD SECURITY IN SUB-SAHARAN AFRICA: EMPIRICAL EVIDENCE AND POLICY PROVISIONS UNDER NIGERIA'S AGRICULTURE PROMOTION POLICY

By

Coker<sup>1\*</sup>, A. A. A., A. A. Ogundeji<sup>2</sup>, B. Khadijat<sup>1</sup>, A.J. Jirgi<sup>1</sup>, H. Sallawu<sup>1</sup> and B. A. Sule<sup>3</sup>

<sup>1</sup>Department of Agricultural Economics & Farm Management, School of Agriculture & Agricultural Technology, Federal University of Technology, Minna, P.M.B. 65, Minna, Niger State.

<sup>2</sup>Department of Agricultural Economics, University of the Free State, P.O. Box 339, Bloemfontein, Republic of South Africa.

<sup>3</sup>Department of Agricultural Economics and Extension Services, Faculty of Agriculture, Ibrahim Badamasi Babangida University, Lapai, Niger State, Nigeria.

\*Corresponding Author's E-mail: [ayodejicoker@futminna.edu.ng](mailto:ayodejicoker@futminna.edu.ng) GSM: 08034091353

## ABSTRACT

*The limited diversity of sub-sectors' contributions to Nigeria's GDP and the undue emphasis on traditional crops at the detriment of high valued enterprises, coupled with ignorance and/or weak enlightenment, aptly justifies the need for agricultural diversification, as an affordable, and sustainable strategy for achieving food security in Africa. Using a case study in Nigeria, with focus on the Nation's Agriculture Promotion Policy, this study empirically unearths the nexus between agricultural diversification and food security. Deploying primary and secondary data cum inferential statistics and content analytical review, the study affirmed the existence of food insecurity and low degree of enterprise diversification among the rural households. Not unexpected, enterprise diversification had a positive, though weak relationship with food security. The existing policy provision was also observed to be sufficiently robust to enhance the food security of Nigerians. These outcomes have obvious implications for the sub-Saharan African countries, given the similarity of circumstance. The study recommended the need for continuous household food security drive through targeted policy measures; innovative resource and enterprise combination orientation; encourage cooperative activities with the view to deepening awareness on enterprise combinations; deepen the food security and diversification strategies in line with the tenets of the national Agriculture Sector Road Map and regional development efforts, as detailed in the African Development Bank high 5 strategy for Africa.*

**KEYWORDS:** Agriculture, diversification, food security, Nigeria, Africa.

## INTRODUCTION

The rising wave of hunger across the globe, particularly in Africa, poses considerable threat to international commitment to ending hunger by 2030 (Food and Agriculture Organisation *et al.*, (2017). According to these development agencies, the population of undernourished people across the globe rose from 777 million in 2015 to 815 million in 2016, with food insecurity particularly endemic in sub-Saharan Africa, South-Eastern and Western Asia. It however affirmed that sub-Saharan Africa remains the region with the highest prevalence of undernourishment. FAO *et al.* (2017) estimated that 243 million Africans may not have had access to sufficient food energy, while the Federal Ministry of Agriculture & Rural Development (FMARD) (2016); Global Food and Nutrition Security (2018) and

United States Agency for International Development (USAID) (2018) noted that food security situation in Nigeria is very challenging. These outcomes thus raise justification for alternative strategy towards attaining food security in Africa, and in Nigeria in particular. Agricultural diversification is viewed as an important strategy for achieving food security in Africa by Waha *et al.*, (2018); Mango *et al.*, (2018), Singh, (2006); Mehta, (2009); Sheereen and Banu (2016). Sheereen and Banu (2016) further alluded that the strategy was deployed as risk and food security instruments during the turbulent years of India's food insecurity challenges. In Nigeria, the focus on agricultural diversification soared following the drop in the prices of oil globally which impacted on the Nigerian economy and partly contributed to economic recession. The review of the sub-sectors'

contributions to the GDP in Nigeria further revealed that only seven of the forty six sub-sectors of the economy (Figure 1) accounted for over 70% of Nigeria's GDP (Federal Ministry of National Planning and Budget, 2017). Similarly, a cursory look into Nigeria's local food supplies across key crops (Figure 2), though, without prejudice to the country's comparative advantage, shows that focus was mainly on the regular staple crops (yam, maize, sorghum and rice) which accounted for over 90% of the crops considered, while high valued commodities like tomato, milk/dairy and fish represented only 4%, with cash crops like cocoa and cotton accounting for less than 2%. This further substantiated the low diversification away from the regular staple crops associated with the poor resource farmers in the rural enclave of Nigeria. Arising from the aforementioned, this study determined the effect of agricultural diversification on food security of rural households; discussed and reviewed strategic provisions for food security through agricultural diversification, as provided in Nigeria's agriculture promotion policy. The justification for this study stems from the need to inform policy makers on the alternate strategy and sustainable measures for ensuring food security through agricultural diversification. The study hypothesized that agricultural diversification does not drive food security among poor resource farmers.

## METHODOLOGY

### Study Area

The study is directed at the Nigeria nation, encompassing a case study, detailing empirical evidence of the nexus between diversification and food security in Oyo State of Nigeria. Nigeria is located in West Africa. The country is situated on Latitude 10.00 N and Longitude 8 00 E (Index Mundi, 2018), with estimated area of 924,000 square kilometers and estimated population of 191.8 million. Nigeria is made up of a Federal Capital Territory and 36 states, including Oyo, which is located in the South-Western part of the country. Agriculture sector contributes 22% of the Gross Domestic Product. The structure of the economy is import dependent, consumption driven and weakly undiversified. About 95% of the country's export and foreign exchange is from oil. Malnutrition is high, with a national mean stunting rate of 32% for fewer than five children (USAID, 2018).

### Sampling Techniques and Sample Size

A multi-stage sampling technique was employed in the collection of data for this study using a sample size equation at 95% confidence interval and 5% precision level, as detailed by Yamane 1967 and Eboh 2009.

## Data Sources, Collection and Analysis

Data for this study were from primary and secondary sources. Data were collected using structured questionnaires administered to 142 respondents. Data collected covered the socio-economic characteristics of farming households, data on enterprise diversification, income, etc. Simpson's diversification index was used to ascertain the extent of enterprise diversification, Foster, Greer and Thorbecke Index was deployed to determine the food security status of respondents, while the Logit Binary Regression model was employed to ascertain the effect of enterprise diversification on food security. The review on Nigeria's Policy direction on diversification was largely based on information from the Agricultural Road Map and Economic Recovery and Growth Plan.

## RESULTS AND DISCUSSION

### Degree of Enterprise Diversification

The Simpson's Enterprise Diversification model returned a mean index at 0.49, ranging from 0 to 0.72. This outcome implies that the extent of diversification was low, while considerable proportion of respondents (47.2) is mono-enterprise in nature. This may not be connected to numerous factors, such as ignorance, poverty, limited access to inputs, little consideration for risk, among other macro and micro-economic factors. Waha *et al.* (2018) showed that households with more farming diversity are more successful in meeting their consumption needs, but only up to a certain level of diversity per hectare of crop land. In addition, Singh, (2006); Ashfaq *et al.*, (2008); Mehta, (2009); Sheereen and Banu, (2016) found that diversification was largely premised on consideration of overcoming food insecurity, response to changing consumer demands and taste, changing government policies, response to external shocks, and as a coping strategy to mitigate challenges emanating from environmental dynamics.

### Food Security Status of Respondents

Towards determining respondents' food security status, food security line for all the households was calculated, following which the food-secure or food-insecure households were isolated. The incidence of food security as detailed in Table 1.0 reveal that majority (51.4%) of the respondents were food insecure. Amaza *et al.* (2006) reported an index of 0.58 (58.0%) in Borno State. Meanwhile, the food security line stands at ₦45,521.55 (\$126) per month, denoting the minimum monthly household income



required to be food secure. In addition, the food security gap stood at 0.1278 (12.78%), thus indicating the extent by which households were below the food security line, while the severity of food insecurity was 0.0731 (7.3%). The results conform with that of Omolori (2017) who obtained food security gap and severity of 13.6% and 8.2% respectively.

#### **Effect of Diversification on Food Security Status of Respondents**

The Logit regression model was employed to empirically determine the effect of agricultural diversification on the food security status of respondents. The results indicated that the pseudo R-square stands 0.5890, implying that 58.9% of the variation in food security status was explained by the independent variables in the model. Further indications from the results revealed that six independent variables (farm size, family labour, years of diversification, cooperative membership, diversification index and farming experience) out of the ten variables in the model were statistically significant at varying probability levels (Table 2.0).

The years of involvement in agricultural diversification, age of household heads, distance to market and household size were negative implying inverse relationship with food security status of the respondents. On the other hand, farm size, number of extension visits, family labour, membership of cooperative, diversification index and farming experience had positive coefficients, signifying direct relationship with food security status of respondents in the study area. Though, diversification index and cooperative membership had weak level of significance. Omotesho *et al.* (2006); Amaza *et al.* (2006) and Oyinbo *et al.* (2015) established that socio-economic factors like household size, labour, gender and income of respondents had direct relationship with food security status of respondents. The result of the marginal effect and partial elasticity estimates of the variables presented in Table 3 shows that the variables considered were both positively and negatively elastic. However, in view of the simplicity of interpretation, the marginal effect estimates were used for this study. The results indicates that the probability of becoming food secured by the respondents increases by the values of their coefficients, with farm size (0.1099), family labour (0.0019), cooperative membership (0.1633), diversification index (0.2024) and farming experience (0.0094). On the other hand, the probability of becoming food secured decreases with the years of diversification. This outcome and the weak diversification index are unexpected, but it may have been due to the fact that diversification activities that the farming households were engaged

in were not viable and profitable and thus not complementary to enhancing the food security situation of the respondents. It is also likely that there are inappropriate combinations of factors of production by the households, either due to ignorance. May (2009) established that the diversification of cropping pattern was germane to minimizing risks and overcoming food insecurity.

#### **Nigeria's Policy Thrust and Strategies for Food Security and Diversification**

Nigeria's Agricultural Promotion Policy (Road Map) is a strategic direction that focuses on redressing food insecurity, import substitution, job creation and economic diversification. Without prejudice to the fact that these priorities are complementary and essentially aimed at reaching same goal, this review is directed at strategies aimed at achieving food security and diversification. The key strategic hub for achieving these goals encompasses productivity enhancement, private sector inclusion and institutional reforms. The focus on productivity enhancement places emphasis on strategies covering enhanced land access to support title recognition and entitlement of land ownership, agro-input access and productivity concerns through priority crops and activities (rice, wheat, meat, fish, dairy milk, soya beans, poultry, horticulture (fruits and vegetables) and sugar), information dissemination to redress market failure, storage, processing, marketing and trade. The private sector strategic focus entails increased access to finance, agri-business and value chain investment development, enhancement of distribution system, reduction of post-harvest losses and increased nutritional outcomes, priority for export market, collaboration with network of value chain actors and the tiers of government and collection of credible data to support policy making and investor planning. The institutional reforms on the other hand, direct attention at institutional setting and roles, cross cutting issues of youths and gender, environment and research. Efforts towards agricultural and economic diversification, as detailed in Nigeria's Economic Recovery and Growth Plan (ERGP) were to be multi-sectoral in approach, covering agriculture, energy, enterprise-led industrial growth, manufacturing and services via science and technology. The FMBNP, (2017) affirmed that these sub-sectors will help restore growth, create jobs, cause structural changes in the economy and of course support food security. The strategic focus of the ERGP (2017-2020) on the other hand, is to be through transformation of the agriculture sector by boosting sub-sector productivities, integrating commodity value chain, enhancing market access and



irrigation expansion. A review of these strategic thrust shows a shift in the focus of the sector for bias towards business orientation and commercialisation, with little emphasis on the traditional development focus of the earlier policy framework, though, without losing sight of the food security objective of the agriculture sector. While not viewing the policy document as a comprehensive and fit for all strategy, it is envisioned that if these policies are holistically implemented, backed with the requisite fiscal requirement, sustained institutional reforms and ethical change, political will and stability, the existing agriculture sector-related challenges will be a thing of the past.

### **CONCLUSION AND RECOMMENDATIONS**

Arising from the outcome of the analysis, it is concluded that substantial population of the rural populace in the study areas are food insecure, degree of agricultural diversification is low, while enterprise diversification and other social economic factors were established to drive food security within the rural households. This conclusion closely aligns with the situation across the sub-Saharan African continent, given the similarity of circumstance. Arising from this, the study recommended the need to: redress the food insecurity situation within the rural setting through specific policy measures directed at farm size expansion, without prejudice to productivity

enhancement, but with emphasis on intensification; embark on continuous sensitization of the farming households on appropriate resource and enterprise combinations, premised on sound enterprise appraisal, with the view to unearthing the benefits of diversification; encourage cooperative activities and group education on enterprise combination, given the need to enhance enterprise diversification and rural household food security. It is also imperative to deepen the food security and diversification strategies in line with the tenets of the national Agriculture Sector Road Map and regional development efforts, as detailed in the African Development Bank high 5 strategy for Africa.

**Table 1.0: Food security status of respondents**

Variable	Frequency	Percentage
Food secure	69	48.6
Food insecure	73	51.4
Total	157	100.0
Food security line / month	₦45,521.55	
Food security incidence	0.4814	
Food security gap	0.1278	
Severity of food insecurity	0.0731	

**Source:** Field Survey, 2018

**Table 2.0: Logit regression results on the effect of agricultural diversification on respondents' food security status**

Variables	Coefficients	Standard Error	z – value
Constant	-8.3145	2.0909	-3.98***
Farm size (X <sub>1</sub> )	1.2268	0.4591	2.67***
Extension visits (X <sub>2</sub> )	0.2082	0.3208	0.65
Family labour (X <sub>3</sub> )	0.0212	0.0091	2.34**
Years of diversification (X <sub>4</sub> )	-0.1213	0.0431	-2.82***
Age (X <sub>5</sub> )	-0.0133	0.0452	-0.29
Distance to market (X <sub>6</sub> )	-0.1960	0.1339	-1.46
Cooperative membership (X <sub>7</sub> )	1.8238	0.9626	1.89*
Household size (X <sub>8</sub> )	-0.0672	0.0620	-1.08
Diversification index (X <sub>9</sub> )	2.2587	1.2972	1.74*
Farming experience (X <sub>10</sub> )	0.1045	0.0486	2.15**
<b>Pseudo R-squared</b>	0.5890		
<b>Chi-squared</b>	0.0000		
<b>Log likelihood function</b>	-40.429264		

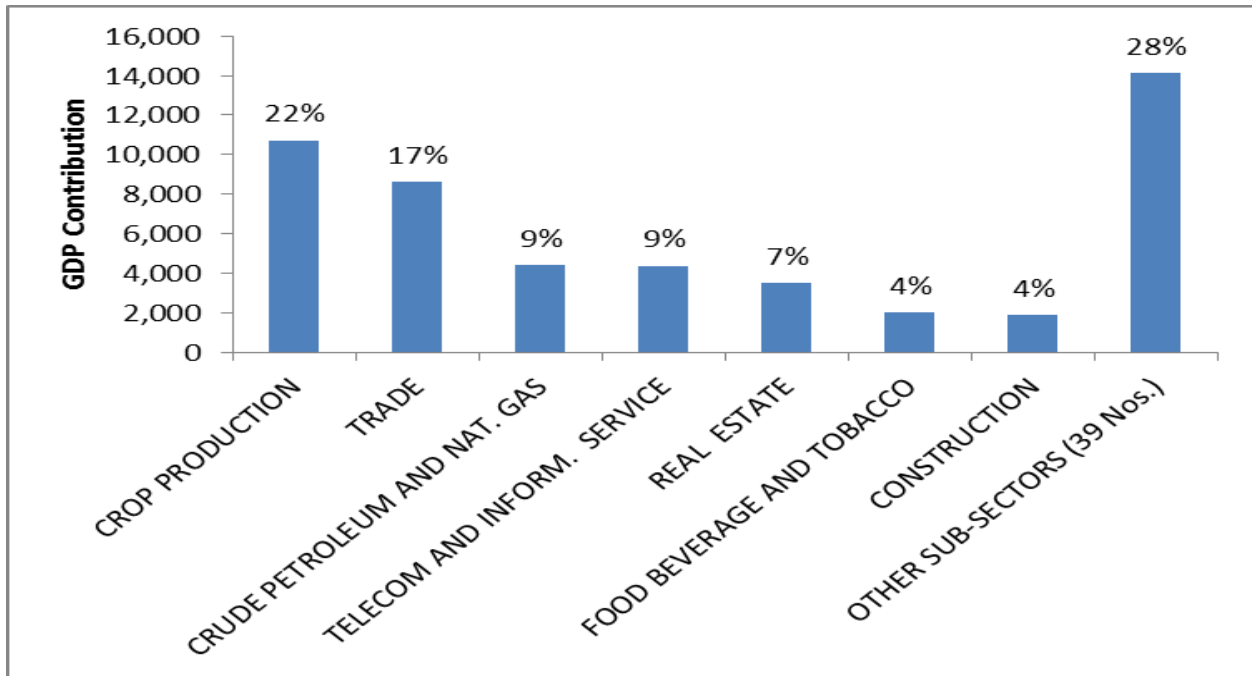
**Source:** Field survey, 2018.

\*Significant at 10%, \*\* significant at 5%, \*\*\* significant at 1%

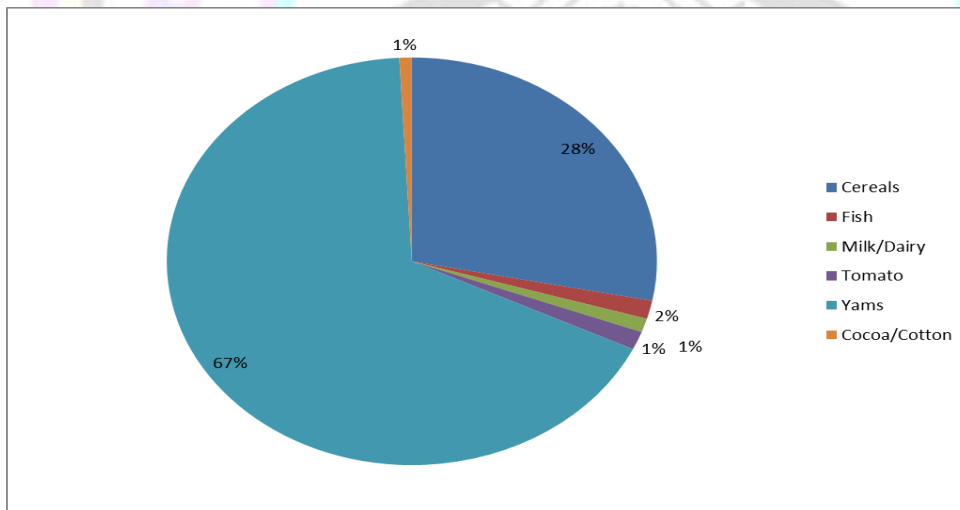
**Table 3.0: Estimates of marginal effect and partial elasticity**

Variables	Marginal effect	Partial elasticity
Farm size (X <sub>1</sub> )	0.1099	1.5032
Family labour (X <sub>3</sub> )	0.0019	1.1355
Years of Diversification (X <sub>4</sub> )	-0.0109	-1.3734
Cooperative membership (X <sub>7</sub> )	0.1634	0.6807
Diversification Index (X <sub>9</sub> )	0.2024	0.8458
Farming experience X <sub>10</sub>	0.0094	1.2724

**Source:** Field Survey, 2018

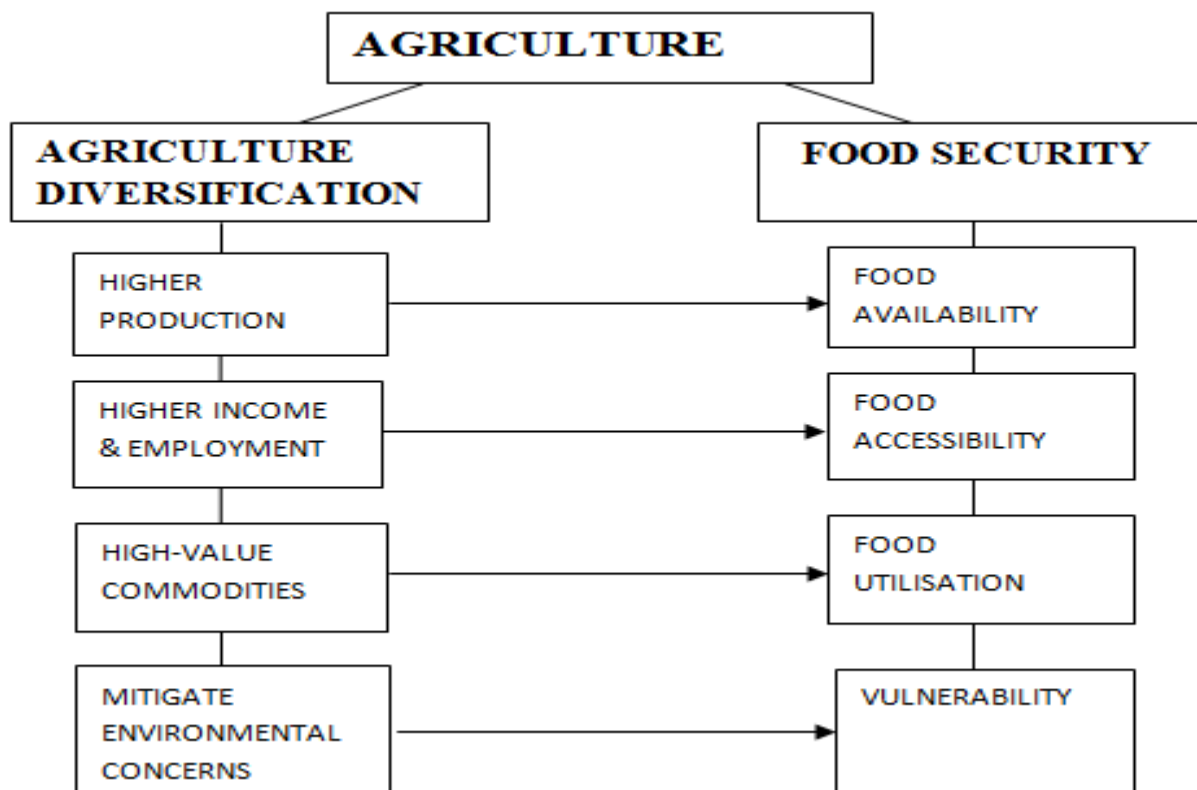


**Figure 1: Sub-sectors' contributions to Gross Domestic Product as at 2016**  
 Source: FMNPB (2017)



**Figure 2: Food production and supplies across key crops (2016 Estimate)**  
 Source: Federal Ministry of Agriculture & Rural Development (2016)





**Figure 3: Agriculture Diversification and Food Security**  
 Source: Sheereen, Z. and Banu, S. (2016)

#### REFERENCES

- Amaza, P. S., Bila, Y. & Iheanacho, A. C. (2006). "Identification of Factors That Influence Technical Efficiency of Food Crop Production in West-Africa: Empirical Evidence from Borno State, Nigeria." *Journal of Agriculture and Rural Development in Tropics and Sub-Tropics*, 107.
- Amaza, P. S., Umeh, J. C., Helsen, J. & Adejobi, A. O. (2006). "Determinants and Measurement of Food Insecurity in Nigeria: Some Empirical Policy Guide." Contributed Poster Prepared For Presentation at the International Association of Agricultural Economists Conference, Gold Coast, Australia.
- Ashfaq, M., S., Hassan, Z.M., Naseer, A., Baig, & Asma, J. (2008). Factors Affecting Farm Diversification in Rice-Wheat; *Pakistan Journal of Agricultural Sciences*. 45 (3): 45- 47.
- Bassinello, T. (2009). Contributions on Food Security and the Capabilities Approval: From Theory to Practice. Proceedings of the FSN Discussion No. 38.
- Bickel, G. (2000). Measuring Food Security in United States: Guide to Measuring Household Food Security. Revised Edition.
- Chalmers, J. (2009). Contributions on Food Security and the Capabilities Approval: From Theory to Practice. Proceedings of the FSN Discussion No. 38.
- Clay, E. (2002). Trade and Food Security: Conceptualizing the Linkages. Paper Presented at FAO, Rome 11-12 July.
- Coker, A.A.A., Akogun, E.A., Adebayo, C.O., Mohammed, U.S., Nwojo, M. Sanusi, H. & Jimoh, H.O. (2016). Gender differentials among subsistence rice farmers and willingness to undertake agribusiness in Africa: evidence and issues for Nigeria. *African Development Review*, 29. No. S2, 2017, 198-212. <https://doi.org/10.1111/1467-8268.12273>
- Delgado, C. L., & Siamwalla, A. (1999). Rural economy and farm income diversification in developing countries, pp. 126-143. In Food security, diversification and resource management: refocusing the role of agriculture (eds.G.H. Peters and Joachim Von Braun). Proceedings of twenty-third International Conference of Agricultural Economists. Brookfield, Vermont, USA: Ashgate Publishing Company.
- Devecchi, C. (2009). Contributions on Food Security and the Capabilities Approval: From Theory to Practice. Proceedings of the FSN Discussion No. 38.

- Eboh, E.C. (2009). *Social and Economic Research. Principles and Methods*. African Institute of Applied Economics, Enugu, Nigeria.
- Food and Agriculture Organisation (FAO), (2002). Food security: Concepts & Measurements, <http://www.fao.org/docrep/005/y4671e/y4671eO6.htm>
- Federal Ministry of Agriculture and Rural Development (FMARD), (2011). Agricultural Transformation Agenda: We Will Grow Nigeria's Agricultural Sector.
- Federal Ministry of Agriculture and Rural Development (FMARD), (2016). The Green Alternative Agriculture Promotion Policy 2016-2020. Building on the Successes of the ATA, Closing Key Gaps. Policy and Strategy Document.
- Federal Ministry of Budget and National Planning (FMBNP), (2017). Economic Recovery and Growth Plan (2017-2020). Federal Capital Territory, Abuja.
- Food and Agriculture Organization, International Fund for Agricultural Development, United Nations International Children Education Fund and World Health Organization, (2001). The State of Food Insecurity, Rome, Italy.
- Food and Agriculture Organization, International Fund for Agricultural Development, United Nations International Children Education Fund and World Health Organization, (2017). The State of Food Security and nutrition in the World: Building Resilience for Peace and Food Security, Rome, Italy.
- Global Food and Nutrition Security, (2018) Diversification important for food security, <https://research.csiro.au/foodglobalsecurity/diversification-important-for-food-security/>.
- Global Social Theory (2017). Food Security, <https://globalsocialtheory.org/concepts/food-security/>.
- Greer, J., Thorbecke, E. (1986). A methodology for measuring food poverty applied to Kenya. *J. Devel. Econ.* 24, 59-74.
- Hayami, Y and K Otsuka (1992): 'Beyond the Green Revolution: Agricultural Development Strategy into New Century' in Jock R Anderson (ed), *Agricultural Technology: Policy Issues for the International Community*, The World Bank, Washington, DC, US, pp 35.
- Index Mundi-Country Facts. <https://www.indexmundi.com/>. Accessed 20<sup>th</sup> March, 2018.
- Karplus, L. (2014). Post-development Theory and Food Security: A Case Study in Swaziland. Capstone Projects-Politics and Government. 20. <https://ir.library.illinoisstate.edu/cppg/20>.
- Liverpool-Tasie, L.S., Kuku, O. and Ajibola, A. (2011). *A Review of Literature on Agricultural Productivity, Social Capital and Food Security in Nigeria*. International Food Policy research Institute. NSSP Working Paper 21.
- Malthus, T. (1798). *An Essay on the Principle of Population*. J. Johnson, London.
- Mango, N., Makate, C., Mapemba, L. and Sopo, M. (2018). The role of crop diversification in improving household food security in central Malawi. *Agriculture & Food Security* 7:7, <http://doi.org/10.1186/s40066-018-0160-x>.
- Mehta, P.K. (2009), "Diversification and Horticultural Crops: A Case of Himachal Pradesh", *Agricultural Development and Rural Transformation Centre, Institute For Social And Economic Change, India*.
- National Population Commission, (2017). NPC Report
- Norton, G.W., Alwang, J., Masters, W.A. (2010). *Economics of Agricultural Development. World Food Systems & Resource Use*. Second Edition. Routledge, Taylor & Francis Group, London & New York.
- Omolori, H.A. (2017). Technical Efficiency and Food Security Status of Fluted Pumpkin Farmers in Selected LGAs of Niger State, Nigeria. M.Tech. Thesis submitted to the Department of Agricultural Economics and Extension Technology, School of Agriculture & Agricultural Technology, Federal University of Technology, Minna, Niger State, Nigeria.
- Omotesho, O. A., Adewumi, M. O., Muhammad-Lawal, A., & Ayinde, O. E. (2006). "Determinants of Food Security among the Rural Farming Households In Kwara State, Nigeria." *African Journal of General Agriculture* 2(1).
- Oyinbo, O., Adah, I.D. and Rekwot, G.Z. (2015). Technical Efficiency-Food Security Nexus in Kaduna State, Nigeria: A Case of Poultry Egg Farmers. *Consilience: The Journal of Sustainable Development*. 14, (2)244-259.
- Scanlan, S.J. (2016). Food Security and Comparative Sociology. Research, Theories and Concepts. *International Journal of Sociology*. Vol. 33, 2003-Issues 3: Across Nations (Part 1). Economic and Political. Taylor and Francis on line.
- Sen, A. (1985). *Commodities and capabilities*. Amsterdam New York, N.Y., U.S.A: North-Holland Sole distributors for the U.S.A. and Canada, Elsevier Science Pub. Co. ISBN 9780444877307.
- Sheereen, Z. & Banu, S. (2016). Agriculture Diversification and Food Security Concerns in India. *IOSR Journal of Agriculture and Veterinary Science* 9(11)56-63.

- Singh, N.P., Ranjit Kumar and R.P. Singh (2006), "Diversification of Indian Agriculture: Composition, Determinants and Trade Implications", *Agricultural Economics Research Review*, Vol. 19.
- United States Development Agency (USDA) (2000). Measuring Food Security in United States: Guide to Measuring Household Food Security.
- United States Agency for International Development, (2018). Request for Proposal (RFP) SOL-72062018r00003-Feed-the-Future Nigeria Agribusiness Investment Activity.
- Waha, K., van Wijk, M.T., Fritz, S., See, L., Thornton, P.K., Wichern, J. & Herrero, M. (2018). Agricultural diversification as an important strategy for achieving food security in Africa. *Glob Chang Biol.* 24(8):3390-3400, doi: 10.1111/gcb.14158.
- Yamane T. (1967). *Statistics: An Introductory Analysis*, second Ed., New York: Harper and Row.





# ANALYSES OF RISK MANAGEMENT STRATEGIES OF SMALL SCALE FLUTED PUMPKIN (*Telferia Occidentalis*) FARMERS IN NASSARAWA STATE, NIGERIA

Olayinka, O.A., Adebayo, C.O. and Ndanitsa, M.A.

Department of Agricultural Economics & Farm Management, Federal University of Technology, Minna, Niger State, Nigeria

\*Corresponding Author's E-mail: [olayinkatimilehin@yahoo.com](mailto:olayinkatimilehin@yahoo.com), GSM: 08063605228

## ABSTRACT

*This study analyzed the risk management strategies of small scale fluted pumpkin farmers in Nassarawa State, Nigeria. A multi-stage sampling technique was adopted in the selection of 163 respondents. Data were collected using a well structured questionnaire complemented with interview schedule and analyzed using descriptive and inferential (logit regression model) statistics. The result showed that majority (48%) of the small scale fluted pumpkin farmers were in the age range of 41 – 50, with a mean age of about 47 years, majority were female (52%) who were married (73%) and had majorly secondary education. The mean farming experience was 15 years, with a mean farm size of about 4ha while the mean income was ₦574,433. The result also showed that the major types of risk associated with fluted pumpkin production in the study area were pest and diseases, excessive rainfall, output price variation and lack of storage facilities while the socio-economic factors affecting the adoption of risk management strategies in the study area were age ( $P < 0.01$ ), educational level ( $P < 0.10$ ), extension contact ( $P < 0.10$ ), amount of credit received ( $P < 0.01$ ), farming experience ( $P < 0.05$ ), farm income ( $P < 0.01$ ) and farm size ( $P < 0.01$ ). The study therefore recommended that government and other stake holders should support fluted pumpkin farmers in the study area by mobilizing extension agents and ensure adequate provision of credit to the farmers as this will increase their capacity to adopt risk management strategies and as such reduce such risks to the bearable minimum.*

**KEYWORDS:** Risk, Fluted pumpkin, Logit regression, Multi-stage, Nassarawa, Production

## INTRODUCTION

Agricultural production is the major activity of the rural people of Nassarawa State with small -scale farmers dominating the farming population. The smallholder farmers control a vast proportion of the productive agricultural resources in Nigeria (Abang and Agom, 2004). They have also been characterized by a low level of resource utilization, low levels of productivity, low returns to labour and a low level of capital investment (Olayide and Heady, 2006). Vegetables are essential components of human diets since they contain important nutritional compounds necessary for human survival. Vegetables, which are rich sources of vitamins, minerals, carbohydrates, protein and dietary fibres are important to the human diet.

Fluted pumpkin (*Telferia occidentalis*) is cultivated across lowland humid tropics of West Africa, including Ghana and Sierra Leone, (Bologi, 2012). Fluted pumpkin production remains entrenched in Nigerian agriculture and forms an important condiment in the national diet (Ibekwe and Adesope, 2010). Amongst the different foods, production and consumption of fluted pumpkin is very important and generate high income for the farmers (Bologi, 2012). It is one of the leading green leafy vegetables in Nigeria. It takes a very important place in the

population's diet because of its affordability and the nutrients it provides. The crop is often grown and consumed in rural and urban areas in Nigeria. It is produced mainly by small-scale farmers, who earn their living from it using limited farm inputs. Fluted pumpkin farmers could make an important contribution to the national food supply where a healthy and expanding market gardening industry exists.

However, small scale farmers in Nassarawa State are facing an ever changing weather, prices, yields, government policies, global competition and other factors that affect their financial returns and overall welfare. Agricultural risk is still a major problem facing the sector in Nigeria and other developing countries of the world. Risk management has become an issue of great concern to policy makers and stakeholders. Fluted pumpkin production in Nigeria cannot attain optimum level without technical expertise in all aspects of the production including risk management.

Risk management has therefore become an issue of great concern to policy makers and stakeholders in the agricultural sector because it can help mitigate the effects of swings in supply, demand and prices, so that the farm business returns can be closer to expectations. Also, appropriate risk management

strategies will help to improve productivity per hectare and farm income, and thus, growth and development in the rural economy.

From the foregoing, it is clear that for increased productivity and positive returns on investment in fluted pumpkin production to be realized, a proper study on the risk management strategies is therefore inevitable. It is in the light of these that this research therefore seeks to provide answers to the following research questions: (i) what are the socio-economic characteristics of small scale fluted pumpkin farmers in the study area? (ii) What are the effects of socio-economic characteristics of small scale fluted pumpkin farmers on the adoption of risk management strategies in the study area? (iii) What are the risks associated with fluted pumpkin production in the study area?

The aim of the study was to analyze the risk management strategies of small scale fluted pumpkin farmers in Nassarawa State, Nigeria and the specific objectives were to: (i) describe the socio-economic characteristics of small scale fluted pumpkin farmers in the study area, (ii) determine the effects of socio-economic characteristics of small scale fluted pumpkin farmers on the adoption of risk management strategies and (iii) identify the risks associated with fluted pumpkin production in the study area.

**Hypothesis of the study:** The null hypothesis tested in this study states that there is no significant difference between selected socio-economic characteristics of small scale fluted pumpkin farmers and adoption of risk management strategies in the study area.

## METHODOLOGY

**The Study Area:** The study was conducted in Nassarawa State of Nigeria. Nassarawa State is centrally located in the Middle Belt region of Nigeria. It has a total land area of 26,875.59 square kilometers and a population of about 1,826,883, according to the 2006 population Census estimate which was projected to be about 2,551,992 in 2018 at 2.5% growth rate per annum with a density of about 67 persons per square kilometer (Nassarawa State Government, 2006). The inhabitants of the Nassarawa State are predominantly farmers and the major crops grown includes rice, yam, melon, guinea corn, beans, maize, sorghum, cassava, millets, groundnut, cowpea, sesame as well as fluted pumpkin.

**Sampling Techniques:** A multi-stage sampling technique was employed in this study. The first stage involved the random selection of two (2) Local Government Areas from the state. The second stage involved random selection of three communities each from the two (2) Local Government Areas selected to

have a total of six (6) communities while the third stage involved the use of Taro Yamane's formula as adopted by Coker *et al.* (2014) to obtain the sample size. Taro Yamane's formula is given as:  $n = \frac{N}{1+N(e)^2}$

Where; n = Sample size, N = Finite population and e = 5% error precision level.

## Methods of data collection

Primary data was used for this study and a well structured questionnaire, complemented with interview schedule was used to elicit information from the respondents. Also, the questionnaire was pre-tested to ensure its validity and reliability for the purpose of this research.

**Method of data analysis:** Descriptive and inferential statistics was used to analyze the data in line with the stated objectives. Objectives i and ii was achieved using mean, frequency distribution and percentages while objective iii was achieved using logit regression model.

## Model Specification

**Logistic regression model:** The logit regression model was used to determine the effect of socio economic characteristics of small scale fluted pumpkin farmers on the adoption of risk management strategies.

The logit model is specified as:

$$Y = \beta_0 + \beta_1 X_1 + \beta_2 X_2 + \beta_3 X_3 + \dots + \beta_n X_n + e_i \quad (1)$$

Where: Y = Adoption of risk management strategies (Yes = 1, No = 0), X<sub>1</sub> = Age (Years), X<sub>2</sub> = Gender (Male = 1, Female = 0), X<sub>3</sub> = Household size (No.), X<sub>4</sub> = Educational level (Years), X<sub>5</sub> = Extension contact (Number of visit), X<sub>6</sub> = Health status (No of days out of work due to illness), X<sub>7</sub> = Membership of cooperative (Membership = 1, 0 otherwise), X<sub>8</sub> = Marital status (Married = 1, 0 otherwise), X<sub>9</sub> = Amount of credit (₦), X<sub>10</sub> = Farming experience (Years), X<sub>11</sub> = Farm income (₦) and X<sub>12</sub> = Farm size (ha), β<sub>0</sub> = Intercept, β<sub>1</sub> – β<sub>12</sub> = Regression coefficients be estimated and e<sub>i</sub> = error term.

## RESULTS AND DISCUSSION

### Socio-economic characteristics of small scale fluted pumpkin farmers in the study area

The socio-economic characteristics of small scale fluted pumpkin farmers considered in this study includes age, gender, marital status, educational level, household size, years of experience, farm income and farm size. The result revealed that majority (48%) of the fluted pumpkin farmers were in the age range of 41 – 50, followed by 30% within the age range of 51 – 60 with a mean age of about 47 years. This implies that the small scale fluted



pumpkin farmers in the study area were within their active age of farming. The result also shows that majority were female (52%) who were married (73%) and had one form of education or the other from quranic (18%), primary (20%) and secondary (43%) as indicated by the respondents. The mean farming experience was 15years which shows that the fluted pumpkin farmers had ample experience in the enterprise. Majority (67%) of the farmers had farm size between 1 – 5ha with a mean farm size of about 4ha; the mean household size was 5 persons while the mean income was ₦574,433 which is an indication that fluted pumpkin production in the study area was lucrative. This result is in line with Onubuogu, (2016) who asserted that the age of the farmers in his study area reveals that majority of the farmers fell within the age range of 41-50 years while Akinbile *et al.*, (2013) stated that majority of their respondents fell within the age range of 31-50 years with a mean age of 40years.

#### **Effect of socio-economic characteristics of small scale fluted pumpkin farmers on the adoption of risk management strategies**

The effect of socio-economic characteristics of small scale fluted pumpkin farmers on the adoption of risk management strategies was analyzed using the logit regression model and the result is as presented in table 2. The result shows that the pseudo R-squared was 0.1018 which shows a relatively good fit for the logit model while the chi-square results shows that the likelihood ratio statistics was statistically significant at 1% level of significance, suggesting that the logit model has strong explanatory power of the variables included in the model.

The result also shows that age was negatively related to the adoption of risk management strategies and statistically significant at 1% level of significance. This is an inverse relationship and it implies that an increase in the age of small scale fluted pumpkin farmers will decrease the likelihood of the farmers adopting risk management strategies. This could be attributed to the fact older people tend to feel reluctant about adopting new technology as they are always comfortable with their old ways of doing things. Also, educational level, extension contact, amount of credit, farming experience, farm income and farm size were positively related to the adoption of risk management strategies and were statistically significant at 10%, 10%, 1%, 5%, 1% and 1% level of significance respectively. This shows a direct relationship; which implies that an increase in these

variables will increase the probability of the farmers to adopt risk management strategies and vice versa. Therefore, the socio-economic factors affecting the adoption of risk management strategies in the study area includes age, educational status, access to extension services, amount of credit received, farming experience, farm income and farm size. This result corroborates the findings of Oguniyi and Ojedokun (2012) who stated that age, farm income and farming experience were some of the significant factors affecting the adoption of risk management strategies in their study area.

#### **Risk associated with fluted pumpkin production in the study area**

The result of the risk associated with fluted pumpkin production in the study area is as presented in table 3. The result shows that majority of the small scale fluted pumpkin farmers in the study area experiences one form of risk or another as indicated by 95% of the respondents. Also, the major types of risk associated with fluted pumpkin production in the study area were perishability (95%), pest and diseases (91%), excessive rainfall (85%), output price variation (82%) and lack of storage facilities (80%) while others includes input price variation (78%), lack of available market (76%), flooding (75%), low market price (73%), yield fluctuation (67%) and drought (61%), as indicated by the respondents. This result is in line with the findings of Hardaker *et al.*, 2004 who stated that the major sources of production risk are weather, pest infestations and diseases, which causes variation in crop yields and in livestock and poultry production. Also, Alimi and Ayanwale (2005) studied risk and risk management strategies in onion production in Kebbi State of Nigeria and found that drought, pests/diseases, input price, output price, theft and lack of capital were the major risk associated with onion production in the study area.

**Test of Hypothesis:** The result of the logit regression model shows that the adoption of risk management strategies was significantly influenced by age ( $P < 0.01$ ), educational level ( $P < 0.10$ ), extension contact ( $P < 0.10$ ), amount of credit received ( $P < 0.01$ ), farming experience ( $P < 0.05$ ), farm income ( $P < 0.01$ ) and farm size ( $P < 0.01$ ). Therefore, the null hypothesis which states that there is no significant difference between selected socio-economic characteristics of small scale fluted pumpkin farmers and the adoption of risk management strategies was rejected.

#### **CONCLUSION AND RECOMMENDATIONS**

This study concludes that the major risk associated with fluted pumpkin production were pest and diseases, output price variation, lack of storage



facilities, input price variation, lack of available market, flooding, low market price, yield fluctuation and drought, and that the socio-economic factors affecting the adoption of risk management strategies were age, educational status, access to extension services, amount of credit received, farming experience, farm income and farm size. Based on these findings, it was therefore recommended that government and other stake holders should support fluted pumpkin farmers in the study area by mobilizing extension agents and ensure adequate provision of credit to the farmers as this will increase their capacity to adopt risk management strategies and as such reduce such risks to the bearable minimum.



**Table 1: Socio-economic characteristics of small scale fluted pumpkin farmers**

<b>Variables</b>	<b>Frequency</b>	<b>Percentage</b>	<b>Mean</b>
<b>Age (years)</b>			
< 31	5	3.06	
31 – 40	24	14.72	
41 – 50	79	48.46	
51 – 60	49	30.06	
> 60	6	3.68	47 Years
<b>Gender</b>			
Male	75	46.01	
Female	88	53.99	
<b>Marital Status</b>			
Single	15	9.20	
Married	118	72.39	
Divorced	9	5.52	
Widowed	21	12.88	
<b>Experience (years)</b>			
1 – 10	46	28.22	
11 – 20	83	50.92	
21 – 30	30	18.40	15 Years
> 30	4	2.45	
<b>Educational Level</b>			
No Formal	21	12.88	
Quranic	30	18.40	
Primary	33	20.25	
Secondary	71	43.56	
Tertiary	8	4.91	
<b>Household Size</b>			
1 – 5	117	71.77	
6 – 10	40	24.53	
11 – 15	6	3.68	5 Persons
> 15	0	0.00	
<b>Farm Income (₦)</b>			
< 201,000	43	26.38	
201,000 – 400,000	44	26.99	
401,000 – 600,000	20	12.26	
601,000 – 800,000	17	10.42	₦574,433
801,000 – 1,000,000	17	10.42	
> 1,000,000	22	13.49	
<b>Farm Size</b>			
< 1	0	0.00	
1 – 5	110	67.48	4ha
6 – 10	23	14.11	
>10	0	0.00	

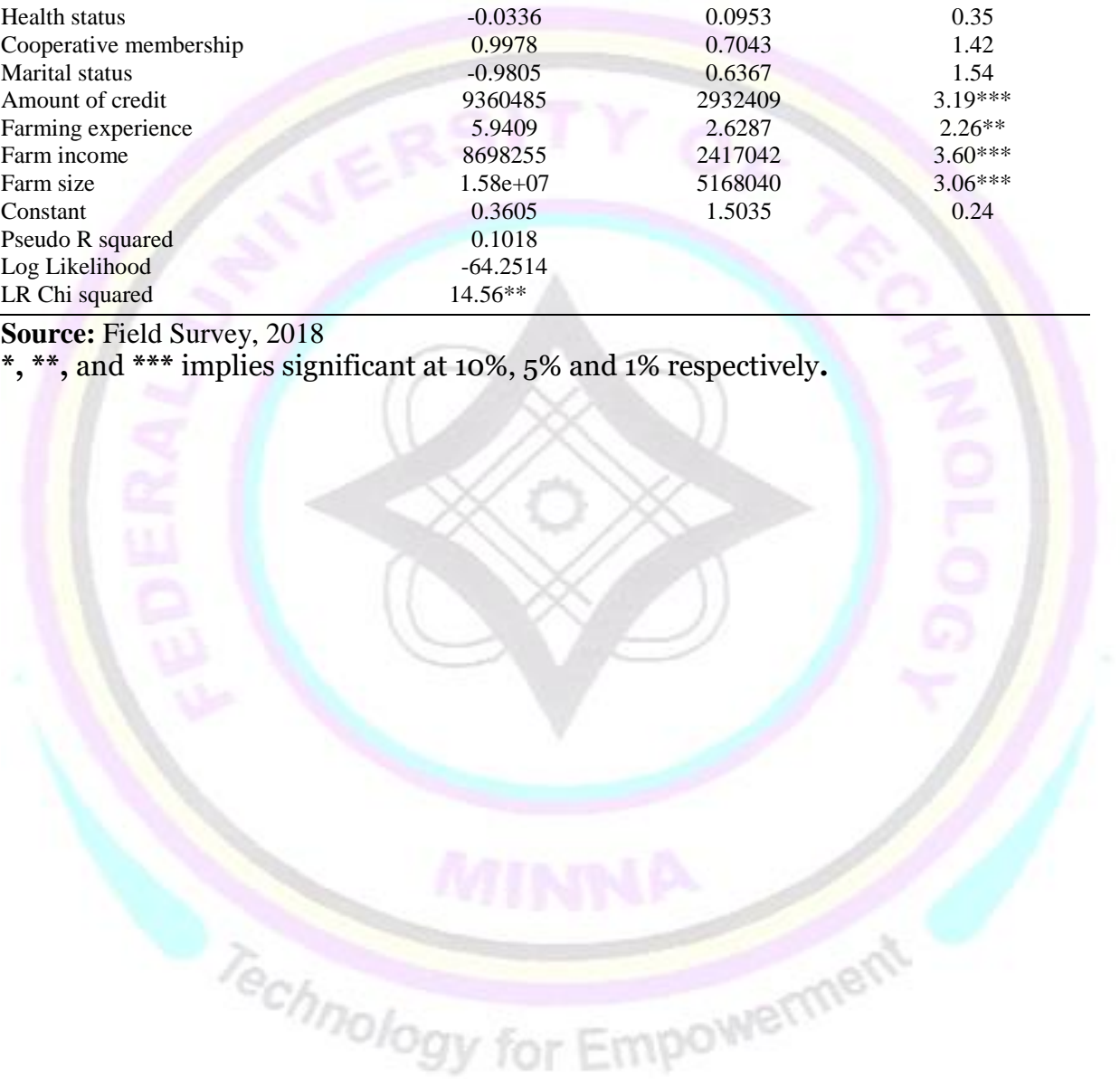
**Source:** Field survey, 2018.

**Table 2: Logit regression result for the effect of socio-economic factors of fluted pumpkin farmers on the adoption of risk management strategies**

<b>Variables</b>	<b>Coefficient</b>	<b>Standard Error</b>	<b>z – value</b>
Age	-237737.6	996724.24	2.46***
Gender	0.2668	0.4983	0.54
Household size	-0.0082	0.1529	0.05
Educational level	5915116	3180169	1.86*
Extension contact	0.0920	0.1201	1.77*
Health status	-0.0336	0.0953	0.35
Cooperative membership	0.9978	0.7043	1.42
Marital status	-0.9805	0.6367	1.54
Amount of credit	9360485	2932409	3.19***
Farming experience	5.9409	2.6287	2.26**
Farm income	8698255	2417042	3.60***
Farm size	1.58e+07	5168040	3.06***
Constant	0.3605	1.5035	0.24
Pseudo R squared	0.1018		
Log Likelihood	-64.2514		
LR Chi squared	14.56**		

**Source:** Field Survey, 2018

\*, \*\*, and \*\*\* implies significant at 10%, 5% and 1% respectively.





**Table 3: Risk associated with fluted pumpkin production in the study area**

Variable	Frequency	Percentage
<b>Types of risk experienced</b>		
Perishability		
Yes	140	85.89
No	23	14.11
Excess rainfall		
Yes	149	91.41
No	14	8.59
Pest and diseases		
Yes	136	83.44
No	27	16.56
Flooding		
Yes	123	75.46
No	40	24.54
Drought		
Yes	101	61.96
No	62	38.04
Price variation		
Yes	135	82.82
No	28	17.18
Yield fluctuation		
Yes	110	67.48
No	53	32.52
Variation in input price		
Yes	128	78.53
No	35	21.47
Low market price		
Yes	120	73.62
No	43	26.38
Lack of available market		
Yes	124	76.07
No	39	23.93
Lack of adequate storage		
Yes	131	80.37
No	32	19.63

**Source:** Field survey, 2018.

## REFERENCES

- Abang, S.O. & Agom, D.I. (2004). Resource use efficiency of small-holder farmers: The case of cassava producers in Cross River State, Nigeria. *Journal of Food, Agriculture and Environment*, 2 (3&4):87-97.
- Bologi, M.U. (2012). Using ugwu to lower diabetes and heart disease risk. Available:<http://blueprintng.com/2012/07/using-ugwu-leaf-to-lower-diabetes-and-heart-disease-risks/>
- Coker, A.A. & Audu M.K. (2014). Agricultural micro-credit repayment performance: Evidence from Minna microfinance bank, Niger State. *African Journal of Agricultural Research* 10 (9), 877 – 885.
- Ibekwe, U.C. & Adesope, O.M. (2010). Analysis of dry season vegetable production in Owerri- West Local Government Area of Imo State, Nigeria. *Journal of Development and Agricultural Economics*, 2(6), 245-249.
- Olayide, S.O. & Heady, E.O. (2006). Introduction to agricultural production economics. Ibadan, Ibadan University Press.



## EFFECT OF SCARIFICATION AND DIPPING DURATION ON THE SEEDLING EMERGENCE AND GROWTH OF GOLDEN SHOWER TREE (*Cassia fistula* LINN)

H. M. Ibrahim<sup>1\*</sup>, Z. O Jubril<sup>1</sup>, B.K. Ameh<sup>1</sup>, R. O. Oyewale<sup>1</sup>, O. M. Olosundes<sup>2</sup>, L. A. Hammed<sup>2</sup>, M. A. Adebisi<sup>2</sup>,

<sup>1</sup>Department of Crop Production Federal University of Technology, Minna, Niger State, Nigeria.

<sup>2</sup>Department of Horticulture Federal University of Agriculture Abeokuta Ogun State, Nigeria

### ABSTRACT

A field experiment was carried out at the Horticultural Nursery of Crop Production department, Federal University of Technology, Minna, between April and August 2017. The aim of the research was to compare the effect of scarification and dipping duration on the seedling emergence and growth of *Cassia fistula* (Golden shower). Golden shower is a multipurpose plant widely used for its ornamental and environmental beautification but it has problem of hard seed coat dormancy which affect the rate, speed and percentage of germination, thus limit seedling production. Scarification method by using mechanical means and acid hold promise in breaking the dormancy of the seeds of golden shower. Field trials were conducted to determine the best method of scarification and dipping duration for optimum germination and seedling growth using gibberellic acid and mechanical method at different dipping duration of 10 Minutes, 20 Minutes, and 30 Minutes. In the experiment, a  $2 \times 4$  factorial arrangement in a Complete Randomized design with five replicates, two factors (i) made up of scarification method by the use of gibberellic acid and by mechanical means (ii) dipping duration of 10 Minutes, 20 Minutes, and 30 Minutes and the use of one line, two lines, and three lines, and the untreated (control). Data collected on germination and seedling growth parameters, were subjected to Analysis of Variance (ANOVA) using DMRT and means were separated using Least Significant Difference (LSD) at 5% level of probability. In the experiment, highest germination percentage (77 %) was recorded in the seeds treated mechanically, followed by the seeds treated with GA<sub>3</sub> (60 %) and the untreated seeds had the least germination percentage (53 %). Also seeds dipped in GA<sub>3</sub> for 30 Minutes had the highest percentage germination followed by 20 Minutes dipped and seeds dipped for 10 Minutes had the least while seeds with three lines had the highest (83 %) followed by the seeds with one line and the seeds with two lines had the least germination percentage. Data were also collected on plant height, number of leaves, leaf area, number of branches and stem girth. It is therefore, concluded that the highest germination and growth yield were recorded on seeds treated mechanically and the interaction effect showed that mechanical scarification using three lines improves the breaking of seed dormancy in *Cassia fistula* (golden shower) and it enhance mass propagation of the ornamental tree.

**Keywords:** *Cassia fistula*, Gibberellic acid, Mechanical Scarification, Dipping duration.

\*Corresponding author. Email: [neneaminu2012@gmail.com](mailto:neneaminu2012@gmail.com) GSM: 08038098324

### INTRODUCTION

*Cassia fistula* (golden shower tree) is an ornamental tree commonly grown for its beauty and medicinal properties, it is a deciduous ornamental tree planted in homesteads and along roadside for beautification and relaxation purposes. It is one of the 400 different species that comprise the genus *Cassia* and it belongs to the subfamily Caesalpinaceae and family Fabaceae (Sartorelli et al. 2009).

Many biologically important compounds were isolated and identified from different parts of *Cassia fistula*, it reversibly suppresses fertility in male rats and Oral administration of aqueous extract from seeds of *Cassia fistula* to mated female rats from day 1-5 of pregnancy at the doses of 100 and 200 mg/kg body weight resulted in 57.1% and 71.4% prevention of pregnancy, whereas 100% pregnancy inhibition was noted at 500 mg/kg body weight (Verma et al. 2009). Presence of hard seed coat hinders the easy propagation of *Cassia fistula*, so thus exhibit seed dormancy. This is a limiting factor for germination seed germination is a sequence of complex processes which leads to the initiation of quiescent embryo in the seed (Hartmann, 2002). Hence this study seeks to provide information on the best scarification method and dipping duration to break hard seed coat in seed of *Cassia fistula* for optimum seedling emergence and growth for large seedling propagation.



## METHODOLOGY

### Experimental location

The experiment was carried out at the experimental nursery of Crop Production department, School of Agriculture and Agricultural Technology, Federal University of Technology, Minna which lies on latitude and longitude  $9^{\circ} 40' N$  and  $6^{\circ} 30' E$  on the equator in the Southern Guinea Savannah of Nigeria.

### Sources of planting material

The seeds of golden shower tree (*Cassia fistula*) for the study was sourced from Federal University of Agriculture Abeokuta, (FUNAAB) Ogun State, top soil, and pots for planting

### Treatment and experimental design

The experiment consist of two factors, firstly is breaking of seed dormancy by mechanical (scarification) means, and with the use of hormone ( $GA_3$ ). Secondly is the duration of dipping of the seeds in the hormone and the number of mechanical lines made on the seed. A total number of 400 seeds were used in the experiment, 200 seeds were used for the mechanical scarification, and 200 seeds were also used for the ( $GA_3$ ), thus giving a  $2 \times 4$  factorial experiment resulting in eight treatment combination arranged in a Complete Randomized Design (CRD) with five replicates.

### Treatment procedure

Mature pods of *C. fistula* were collected, the pods were gently crushed and the seeds removed. The seeds were thoroughly washed with distilled water to remove adhering pericarp parts, these seeds were air-dried and tested for viability by floatation method in distilled water. This involves separating the seeds into “floaters” and “sinkers”. Viable seeds were considered to be those that sank. Three sets of 50 seeds were put in different Petri dishes and were soaked in equal volume of 20 ml of gibberellic acid ( $GA_3$ ) at dipping duration of 10, 20, and 30 minutes respectively, making the total of 150 seeds used. As the timing elapsed, the acid solution was poured and the seeds were thoroughly rinsed with distilled water to ensure proper cleaning from the remains of acid ( $GA_3$ ). For the scarified seeds, 50 seeds were subjected to lining once, another set of 50 seeds were lined twice, and the third set of 50 seeds were lined trice making the sum total of 150 seeds that was mechanically scarified. And 100 seeds were left untreated. Thereafter, the treated and the untreated seeds were sown.

### Filling of the planting pots and sowing of the seeds

Top soil was collected from Horticultural Nursery and air dried, 14 kg of the air dried soil was weighed into the planting pots, the polythene pots were perforated to prevent water logging. The seeds (treated and the untreated) were sown at 3 cm depth into the soil and the spacing was  $(5 \times 5)$  cm on the planting pot containing 14 kg of soil with a total of ten seeds per pot.

### Data collection

Data were collected on the following parameters number of days to 50% germination, number of leaves, number of branches, Plant height (cm), Stem girth (mm), and Leaf area ( $cm^2$ )

### Statistical analysis

Data collected were subjected to Analysis of Variance (ANOVA) using DMRT and means were separated using Least Significant Difference (LSD) at 5% level of probability.

## RESULTS AND DISCUSSION

### Effect of $GA_3$ /Mechanical and dipping duration on germination of Golden shower

The result of effect of GA<sub>3</sub>/Mechanical and dipping duration on germination of golden shower at 5-30 Days After Sowing (DAS) was shown in the **Table 1**. GA<sub>3</sub>/Mechanical had significant ( $P \geq 0.05$ ) effect on germination of golden shower, at 30 DAS seeds treated using mechanical method resulted to the highest germination rate of 7.8 compared to seeds treated with GA<sub>3</sub> and Control produced the lowest germination. Dipping duration had significant effect on germination of golden shower at 0, 10, 20 and 30 with 30 minutes dipping duration resulting to highest germination. The interaction between GA<sub>3</sub> and Mechanical and dipping duration were not significant.

#### **Effect of GA<sub>3</sub>/ Mechanical and dipping duration on number of leaves of *Cassia fistula***

The result of the effect of GA<sub>3</sub>/Mechanical and dipping duration on number of leaves of golden shower at 5-13WAS was shown in Table 2. GA<sub>3</sub>/Mechanical had a significant ( $P \geq 0.05$ ) effect on number of leaves at 5-13WAS. Seed treated mechanically resulted to the highest number of leaves of 103.3 compared to other seed treated with GA<sub>3</sub>, and control produced the lowest number of leaves 80. Dipping duration had a significant effect on numbers of leaves on golden shower at 0, 10, 20 and 30 Minutes with dipping duration at 30 Minutes resulted to the highest germination at 13 WAS (92.6) compared to other dipping duration and control produced the lowest number of leaves 80 also seeds with 3 lines produced the highest number of leaves of 107 at 13WAS compared to seeds with 1 line and 2 lines. The interaction between GA<sub>3</sub>/Mechanical and dipping duration were not significant on golden shower.

#### **Effect of GA<sub>3</sub>/ Mechanical and dipping duration on number of branches of *Cassia fistula***

The effect of the GA<sub>3</sub>/Mechanical and dipping duration on number of branches of golden shower was shown in Table 3. GA<sub>3</sub>/Mechanical had significant ( $P \geq 0.05$ ) effect on number of branches at 5-13 WAS. Seeds treated using mechanical method resulted to the highest number of branches at 13 WAS (20.4) compared to other seeds treated with GA<sub>3</sub>. Control produced the lowest number of branches 14.6. Dipping duration had significant effect on the seeds of *Cassia fistula* at 0, 10, 20, and 30 Minutes. 30 Minutes dipping duration resulted to the highest number of branches compared to other dipping duration and also seeds with 3 lines produced the highest number of branches (121.3) compared to line 1 and 2. The interaction between GA<sub>3</sub>/Mechanical and dipping duration were not significant.

#### **Effect of GA<sub>3</sub>/ Mechanical and dipping duration on plant height of *Cassia fistula***

The result of the effect of GA<sub>3</sub>/Mechanical and dipping duration on plants height of golden shower is shown in Table 4. GA<sub>3</sub>/Mechanical had a significant ( $P \geq 0.05$ ) effect on plant height of golden shower 5-13 WAS. Seeds treated using mechanical method have the highest plant height at 13 WAS 32.0 compared to GA<sub>3</sub> and control. Control produced the lowest plant height 25.6. The dipping duration had a significant effect on golden shower at 0, 10, 20 and 30 minutes. 30 Minutes dipping duration resulted to the highest plant height 31.3 compared to other dipping duration and also line 3 produced the highest plant height at 13 WAS compared to line 1 and 3. The interaction between GA<sub>3</sub>/Mechanical and dipping duration were not significant.

#### **Effect of GA<sub>3</sub>/ Mechanical and dipping duration on stem girth of *Cassia***

The result of the effect of GA<sub>3</sub>/Mechanical and dipping duration of stem growth of cassia fistula was shown in table 5. GA<sub>3</sub>/Mechanical had a significant ( $P \geq 0.05$ ) effect stem girth at 5-13 WAS. Seeds treated using mechanical method resulted to the thickest stem girth at 13 WAS (0.8) compared to seeds treated with GA<sub>3</sub> and control produced the lowest value for stem girth (0.7). The dipping duration had a significant effect on the plant of golden shower at 0, to 20 and 30 minutes with 30 minutes dipping having the highest stem girth value (0.8) compared to other dipping duration and also line 2 and 3 produced the highest stem (0.9) and seeds with 1 line scarification having the least. The interaction between GA<sub>3</sub>/Mechanical and dipping duration were not significant.

#### **Effect of GA<sub>3</sub>/ Mechanical and dipping duration on leave area of *Cassia fistula***

The result of the effect of GA<sub>3</sub>/Mechanical and dipping duration on leaves area of the plant of cassia fistula is shown in Table 6. V/Mechanical had a significant ( $P \geq 0.05$ ) effect on leave area at 5-13 WAS seed treated using mechanical resulted to the highest leaves area at 13WAS (88.7) compared to other seed treated with GA<sub>3</sub>, control produced the lowest leaves area (61 cm<sup>2</sup>). The dipping duration had a significant effect on the plant of cassia fistula at 0, 10, and 20 and 30 minutes with 30 minutes dipping resulted to the highest leave area( 83.9 cm<sup>2</sup>) compared to other dipping duration and also line 3 produced the highest leave area at 13 WAS(97.1 cm<sup>2</sup>) compared to line 1 and 2. The interaction between GA<sub>3</sub>/Mechanical and dipping duration were not significant.

## **DISCUSSION**



The result of this study on scarification method and dipping duration on germination of *Cassia fistula* revealed that *Cassia fistula* treated using mechanical method produce the highest germination rate, seeds with three (3) line produced the highest germination, the finding from this study was in agreement with (David & Midcap, 2007) who said Mechanical scarification is a technique for overcoming the effect of an impermeable seed coat. Mechanical scarification can be done by rubbing seeds between two pieces of sandpaper or using a file, a pin, or a knife to rupture the seed coat, cracking with hammer or a vice. Also scarification method and dipping duration on number of leaves of *Cassia fistula* revealed that *Cassia fistula* treated using mechanical method produce the highest number of leaves and line three (3) produced the highest number of leaves, this was in agreement with Todaria and Negim (1992) which were of the opinion that mechanical scarification helps in physically weakening of the impermeable layer in the seed coat allowing water and air to enter the seeds thereby permitting the embryo to overcome the mechanical restriction of surrounding tissues. *Cassia fistula* seeds treated mechanical produced the highest number of branches, highest plant height, highest stem girth, highest and leaves area respectively, these finding was in agreement with the work of Pant & Chauhan (2013) that reported that soaking of *Cassia* seeds in water for 24 hours after mechanical scarification (by rubbing the seeds with sand paper) showed a significant level of improved germination (76.88%) when compared to sulfuric acid scarification, hot water and alcohol treatments. This result is also consistent with the results of other authors such as Al- Menaie et al. (2010) for *C. fistula* in Kuwait, Babely and Kandy (1998) for *C. fistula* in Egypt, Karaboon et al. (2005) for *C. fistula* in Thailand and Nalawadi et al. (1977) for *C. fistula* in India. Consequently, mechanical scarification is an excellent, cheap and practical treatment to be used to break seed coat dormancy in tropical plant species.

## CONCLUSION AND RECOMMENDATION

Based on the result from the experiment it could be therefore concluded that, the highest germination, was recorded in seeds treated using mechanical scarification method with line 3 showing an effective germination of the seeds of *Cassia fistula* hence, for proper growth, broader leave area, taller plant height, a reasonable number of leaves, number of branches, and a thicker stem girth, the use of mechanical scarification method with line 3 dipping duration and the use of GA<sub>3</sub> as scarification at 30 minutes duration is very effective for the growth of *Cassia fistula*. From the result obtained, it is recommended that *Cassia fistula* seed treated using mechanical scarification method was effective and viable for the breaking the seed dormancy in *Cassia fistula* seeds for it enhance the growth and germination of (*Cassia fistula*). The dipping duration should be 30 minutes dip for GA<sub>3</sub>, while the line should be line 3 for optimum performance, and to obtain flower with good vigor.

## REFERENCES

- Al-Menaie, H.S.; O. Al-Ragam, A.; Al-Shatti, M.; Mathew, and Suresh, N. (2010). The effects of different treatments on seed germination of the *Cassia fistula* L. and *Cassia nodosa*
- Babely GS, Kandy AK. (1998) On finding out some suitable pre-treatment for *Cassia fistula* Linn seeds. Journal of Tropical Forestry ;4:147-154.
- David, F.H. and Midcap, J.T. (2007). Seed Propagation of Woody Ornamentals. <http://www.adis.ifas.ulf.edu/EP029.10/04/0> Dormancy in Indian rice grass. Journal of Range Management 1999;52:646-650.
- Hartmann, H.T.; Kester, D.L.; Davies F.T. and Geneve, R.L. (2002). Plant Propagation: Principles and Practices. Pearson Education limited, New Jersey.
- Hadas, A. 2004. Seed bed preparation. The soil physical environment of germinating seeds In: Hand book of Seed Physiology Application to Agriculture. The Harworth Prees: Inc., Binghamton New York pp 3-49.
- Karaboon, S., Ripona, S., Thanapornpoonpong, S. N., Pawelzik, E., & Vearasilp, S. (2005, October). *Breaking dormancy and optimum storage temperature of golden shower (Cassia fistula) seeds*. In Conference on International Agriculture Research for Development. Stuttgart-Hohenheim, Tropentag <http://www.tropentag.de/2005/abstracts/full/258.pdf>
- Nalawadi UG, Bhandary KR, Chandrashekar T. (1977). Germination of *Cassia fistula* L. Current Research in Horticulture. Abstract. 46.36454 (3): 42-43.
- Pant, G., & Chauhan, U. K. (2013). Germination behavior of *Cassia tora* seeds in various pre-sowing treatment methods. *International Journal of Pharma and Bio Sciences*, 4(3): (B) 773 – 778. [http://www.ijpbs.net/cms/php/upload/2598\\_pdf.pdf](http://www.ijpbs.net/cms/php/upload/2598_pdf.pdf)



- Sartorelli, P., C.S. Carvalho, J.Q. Reimao, Roxb. in Kuwait. African Journal of Agricultural M.J.P. Ferreira and A.G. Tempone, 2009. Antiparasitic activity of biochaninA, an isolated isoflavone from fruits of *Cassia fistula* (Leguminosae). Parasitol Res., 104: 311-314.
- Todaria NP, Negim AK. (1992) Pre-treatments of some Indian cassia seeds to improve their germination. Seed Science and Technology;20:583-588. various pre-treatment on germination in the perennials purge *Euphorbia hirsuta* All Flora, 201: 633-641.
- Verma S, Sharma RK, Srivastava DK. (2009) Seed germination and viability of *Canna indica* L. seed germination, viability and invigoration studies in medicinal plants of commercial value. In Proceedings of the national seminar on the frontiers of research and development in medicinal plants. Journal of Medicinal and Aromatic Plant Sciences;22(4a),426-428.



**Table: 1 Effect of GA<sub>3</sub>/Mechanical and dipping duration on germination of *Cassia fistula***

Treatment Method	5DAS	10DAS	15DAS	20DAS	25DAS	30 DAS
Mechanical	1.2a	3.8a	6.2a	6.8a	7.5a	7.7a
GA <sub>3</sub> Control	0.5ab	2.6ab	4.3b	4.1b	5.1b	6.0b
SE±	0.1	0.2	0.3	0.3	0.3	0.7
Dipping Duration (Minutes)						
GA <sub>3</sub>						
10	0.3a	1.6a	3.0a	5.3a	4.3a	5.3b
20	0.3a	2.0a	3.3a	5.3a	4.3ab	5.6ab
30	1.0a	3.3a	4.6a	5.3a	6.3b	7.0a
Mechanical						
Line 1	2.0a	4.6a	6.0b	7.0ab	7.6a	8.0a
Line 2	0.6b	3.6ab	5.3bc	5.7b	7.0a	7.0ab
Line 3	1.0b	3.3ab	7.3a	8.0a	.0a	8.3a
SE±	0.2	0.3	0.3	0.4	0.3	0.3
Interaction G x M	NS	NS	NS	NS	NS	NS

Means followed by the same letter(s) in a column for the same factor are not significantly different at  $P \leq 0.05$  by

Duncan Multiple Range test (DMRT) NS= Not Significant

**Table 2: Effect of GA<sub>3</sub>/ Mechanical and dipping duration on number of leaves of *Cassia fistula***  
**Number of Leaves**

Treatment Method	5WAS	7WAS	9WAS	11WAS	13WAS
Mechanical	25.3a	41.7a	62.8	82.6a	103.3a
GA <sub>3</sub>	19.1b	34.0b	52.8b	68.5b	89.5b
Control	13.3c	25.3c	44.3c	62.3c	80.0b
SE±	1.1	1.4	1.85	2.59	2.4
Dipping Duration					
GA <sub>3</sub>					
10	18.0a	30.3b	45.0b	56.0b	82.3ab
20	18.3a	35.6a	56.3a	75.6a	92.6a
30	21.0a	36.0a	57.3a	74.0a	93.6a
Mechanical					
Line 1	23.6a	39.3a	61.3a	78.3a	99.6a
Line 2	26.0a	42.3a	62.0a	83.6a	103.3a
Line 3	26.3a	43.6a	65.3a	85.6a	107.0a
SE±	1.7	3.3	2.6	3.1	3.6
Means followed by the same					
Interaction G x M	NS	NS	NS	NS	NS

letter(s) in a column for the same factor are not significantly different at  $P \leq 0.05$  by Duncan Multiple Range test (DMRT) NS= Not Significant

**Table 3: Effect of GA<sub>3</sub>/ Mechanical and dipping duration on number of branches of *Cassia fistula***  
**Number of Branches**

Treatment Method	5WAS	7WAS	9WAS	11WAS	13WAS
Mechanical	5.6a	8.8a	12.5a	16.0a	20.4a
GA <sub>3</sub>	4.0b	8.2a	11.8a	15.5a	20.1a
Control	3.3b	5.6b	8.6b	11.0b	14.6b
SE±	0.2	0.3	0.3	0.4	0.4
Dipping Duration (Minutes)					
GA <sub>3</sub>					
10	13.3a	7.3b	11.3a	14.6b	19.6a
20	4.3a	8.3a	11.6a	15.7a	20.0a
30	4.3a	9.0a	12.6a	15.3a	20.6a
Mechanical					
Line 1	5.3a	8.3a	12.0b	16.6ab	20.0a
Line 2	5.6a	9.0a	12.3b	15.3b	20.0a
Line 3	6.0a	9.3a	13.3a	16.6a	21.3a
SE±	0.3	0.4	0.5	0.6	0.7
Interaction G x M	NS	NS	NS	NS	NS

Means followed by the same letter(s) in a column for the same factor are not significantly different at  $P \leq 0.05$  by Duncan Multiple Range test (DMRT) NS = Not Significant



**Table 4: Effect of GA<sub>3</sub>/ Mechanical and dipping duration on plant height of *Cassia fistula***

<b>Plant height (cm)</b>					
Treatment Method	5WAS	7WAS	9WAS	11WAS	13WAS
Mechanical	7.3a	16.3a	19.5a	25.6a	32.0a
GA <sub>3</sub>	7.6a	14.4b	17.7b	23.6b	30.5b
Control	5.3b	8.6c	14.3c	20.0c	25.6c
SE±	0.2	0.6	0.4	0.4	0.5
Dipping Duration					
GA <sub>3</sub>					
10	6.6b	13.0b	17.3a	23.6a	30.0a
20	8.0a	14.6a	18.0a	23.6a	20.3a
30	8.3a	15.6a	18.0a	23.6a	31.3a
Mechanical					
Line 1	7.0ab	15.3a	19.0a	25.0a	31.6a
Line 2	7.0ab	16.6a	19.0a	25.6	31.7a
Line 3	8.0a	17.0a	20.6a	26.3a	32.6a
SE±	0.4	0.6	0.7	0.8268	0.8
Interaction	NS	NS	NS	NS	NS
G x M					

Means followed by the same letter(s) in a column for the same factor are not significantly different at  $P \leq 0.05$  by Duncan Multiple Range test (DMRT) NS= Not Significant

**Table 5: Effect of GA<sub>3</sub>/ Mechanical and dipping duration on stem girth of *Cassia***

**Stem Girth (mm)**

Treatment Method	5WAS	7WAS	9WAS	11WAS	13WAS
Mechanical	0.2a	0.4a	0.5a	0.74a	0.8a
GA3	0.2a	0.3ab	0.5ab	0.6b	0.7b
Control	0.16b	0.3c	0.4b	0.6b	0.7b
SE±	0.01	0.01	0.01	0.02	0.02
Dipping Duration					
GA3					
10	0.2a	0.3ab	0.5ab	0.6b	0.7a
20	0.2a	0.4a	0.5a	0.7a	0.8a
30	0.2a	0.4ab	0.6a	0.7ab	0.8a
Mechanical					
Line 1	0.2a	0.4b	0.5a	0.7ab	0.8a
Line 2	0.2a	0.5a	0.5a	0.7a	0.90a
Line 3	0.3a	0.5a	0.6a	0.7a	0.9a
SE±	0.0	0.02	0.02	0.02	0.02
Interaction G x M	NS	NS	NS	NS	NS

Means followed by the same letter(s) in a column for the same factor are not significantly different at  $P \leq 0.05$  by Duncan Multiple Range test (DMRT) NS= Not Significant

**Table 6: Effect of GA<sub>3</sub>/ Mechanical and dipping duration on leaf area of *Cassia fistula***

Treatment Method	Leave Area (cm <sup>2</sup> )				
	5WAS	7WAS	9WAS	11WAS	13WAS
Mechanical	0.6.5a	16.3a	31.8a	61.4a	88.7a
GA3	0.12	15.1b	30.4a	54.9b	79.2b
Control	5.2b	10.6c	22.2b	41.0b	61.0c
SE±	0.1	0.4	0.9	1.7	2.3
Dipping Duration					
GA3					
0	5.2b	10.6c	22.1c	41.0d	61.0d
10	5.4b	13.8b	28.0b	51.0c	73.6c
20	6.5b	15.4a	31.1a	53.9b	79.9b
30	6.5a	16.0a	32.1a	59.7a	83.9a
Mechanical					
Line 1	5.9a	15.3a	28.7c	54.3c	84.1c
Line 2	6.8a	16.6a	31.7b	63.2b	85.0b
Line 3	6.9b	16.7b	35.0a	66.8a	97.1a
SE±	0.2	0.7	1.4	3.0	3.9
Interaction G x M	NS	NS	NS	NS	NS

Means followed by the same letter(s) in a column for the same factor are not significantly different at  $P \leq 0.05$  by Duncan Multiple Range test (DMRT) NS= Not Significant

# MACROECONOMIC POLICY MANAGEMENT FOR SUSTAINABLE FOOD SECURITY OUTCOME IN NIGERIA

UKPE, U. H.\*<sup>1</sup>, C. R. F. DJOMO<sup>2</sup>, S. A.OLAYIWOLA <sup>1</sup> and AUDU, I. A..<sup>1</sup>

<sup>1</sup> Department of Agricultural Economics and Extension, Federal University Wukari, P.M.B. 1020, Wukari, Taraba State, Nigeria

<sup>2</sup> Department of Agricultural Economics, Federal University of Agriculture Makurdi, P.M.B. 2373, Makurdi, Benue State, Nigeria

\*Corresponding Author's E-mail: [ukpe@fuwukari.edu.ng](mailto:ukpe@fuwukari.edu.ng), GSM: [08020511613](tel:08020511613)

## ABSTRACT

*The study analyzed the effect of monetary and fiscal policies on food production index an indicator of food security from 1985 to 2016. The results of the study showed that government expenditure on agriculture and exchange rate were stationary at level while food production index, inflation rate and interest rate were stationary at first difference; There was a single cointegrating equation showing that there was a long run relationship among variables. The result of the vector error correction model (VECM) revealed that in the short run, only government expenditure positively affected food production index significantly. In the long run government expenditure on agriculture, inflation rate and interest rate at negatively affected food production index and exchange rate positively affected food production index. It was therefore recommended that government budget allocation to agriculture should meet up with the Maputo agreement to ensure the necessary increase of food production.*

**KEYWORDS:** food security, policy, inflation rate, interest rate, exchange rate

## INTRODUCTION

There are different definitions of food security developed by different sources. The World Bank report on poverty and hunger defines food security as access by all people at all times to enough food for an active and healthy life (World Bank, 1996). According to the definition of the Food and Agriculture Organization (FAO), food security is a situation that exists when all people, at all times, have physical, social and economic access to sufficient, safe and nutritious food that meets their dietary needs and food preferences for an active and healthy life. This involves four dimensions: adequacy of food supply or availability; stability of supply, without seasonal fluctuations or shortages; accessibility to food or affordability; and utilization, quality and safety of food (Applanaidu, Bakar and Baharudin, 2014). There are four types of food security indicators, namely: average dietary energy supply adequacy; average value of food production; average protein supply; and share of dietary energy supply derived from cereals, roots and tubers. For the purpose of this study, average value of food production was used and was proxied as food production index.

Asides the country's rapid annual population growth rate, other issues are equally accountable for Nigeria's emergent food insecurity amongst which is decades of bad policies in the agricultural sector, prominent among which are lack of infrastructural development, lack of incentives such as loan for farmers and undercapitalization of the sector which has accounted for poor performance of the sector thus fueling food insecurity in Nigeria.

Attainment of food security is imperative in any country. This is why all developed and developing countries make considerable efforts to increase their food production capacity. It should be noted that availability of food alone does not seem sufficient to explain the attainment of food security in a country. Food can be available in a country because of effective agricultural policy; good harvest in a particular year or massive importation of food; or food handout (aid) (Ojo and Adebayo, 2012).

Monetary and fiscal policies play a key role in the promotion of the main government objective of promoting the welfare of citizens. Monetary policy constitutes the major policy thrust of the government in the realization of various macroeconomic objectives (Ogar *et al.*, 2014)). Fiscal policy is considered an important variable which may determine changes in national income in developing countries like Nigeria (Abdurrauf, 2015). According



to Abata *et al.* (2012), the objectives of fiscal and monetary policies in Nigeria are wide ranging. These include increase in gross domestic product growth rate, reduction in the rates of inflation and unemployment, improvement in the balance of payments, accumulation of financial savings and external reserves as well as stability in naira exchange rate. The policy as well as instruments applied to attain these objectives however have been until recently been far from adequate as undue reliance has been placed on fiscal policy rather than monetary policy in Nigeria. Public expenditure policy is one of the most important instruments of public sector policy. Public expenditure is the government spending from revenue derived from tax and other revenue. The agricultural sector is due to its relevance in the provision of raw materials for industries and most importantly the provision of food for the teeming Nigerian population and also serving as a source of foreign exchange for the economy (Adofu, Abula and Audu, 2010). Food and Agricultural organization (FAO) recommended that 25 percent of government capital budget allocation be assigned to the agricultural development capital budget. In Nigeria, this has not been achieved by the government, thereby affecting government programmes and policies for the sector (Iganiga and Unemhilin, 2011).

Interest rate constitutes a very important factor affecting the productivity of agriculture. A real interest rate is an interest rate that has been adjusted to remove the effects of inflation to reflect the real [cost of funds](#) to the borrower and the real yield to the lender or to an investor. Anyawu, Ukeje, Amoo, Igwe and Eluemunor (2010) observed that one of the purposes of the policies of agricultural credit over the years was the provision adequate credit to the agricultural players at an affordable cost and at the right time. Inflation is undeniably one of the most leading and dynamic macroeconomic issues confronting most economies of the world as its effects penetrate more deeply into nation's life due to prevailing increase in prices (Olatunji *et al.*, 2010). The rate-of-exchange policy influences prices paid domestically to producers of export goods. For the rest of the world what counts are prices expressed in foreign currency.

The development of agricultural policy in Nigeria for some years back has been based on the understanding that agriculture is the only panacea to the achievement of an inclusive growth due to its inward linkages. Hence, the focus of the agricultural development efforts have been to improve and sustain the sector to play this assigned role with special emphasis on the attainment of a sustainable level in the production of basic food (Fan *et al.*,

2008). Though some policies adopted by government showed positive impact on food production, the positive effects later turned out to be insignificant. Many investigations have found that persistent rise in prices discourages investment in crops production, reduce agricultural output and consequently the objective of food security becomes threatened. In view of the above, the study aim at to analyze the effect of fiscal and monetary policies on food security outcome in Nigeria

### Literature Review

In Ilaboya *et al.*, (2012) view, the panacea for food security lies in improving agricultural productivity; enhancing science and technology; building farmers capacity; facilitating access to the market; and good governance amongst others. Climatic changes have varying effects on agriculture and, therefore, food security. Higher temperatures result in decreased agricultural productivity and production, high evaporation rates, reduced soil moisture and lowering of the groundwater table and shrinking of surface water. Heat stress reduces leads to rapid deterioration and wastage of farm produce.

Applanaidu, bakar and Baharudin in their attempt to analyse the dynamic relationship between selected macroeconomic variables and food security in Malaysia using VAR approach found that biodiesel production, exchange rate, food price index, GDP, government development expenditure on rural development and population accounted for variation in food security. Biodiesel production, exchange rate and government expenditure on rural development will give the highest shock to food security in year the long run whereas, exchange rate and population in will give the highest shock in the short run. Oke (2015) examining the determinants of national food security in Nigeria concluded that the determinants of food security actually captured using the agriculture gross domestic product, per capita income, food import, food export and population all proved to be determinants because they all had effects on food prices relative to food security.

Empirically investigating the impact of macroeconomic policies on agricultural output by Muftaudeen and Hussainatu, (2014), the study found a significant variation in Nigeria's agricultural food output to be due to changes in exchange rate and government expenditure movements. The result also indicated that price instability as a result of inflation rate had a negative impact on agricultural output implying that increase in inflation raised the nominal price of agricultural inputs through its multiplier effects thereby discouraging agricultural investment for increased food production (Muftaudeen and Hussainatu, 2014). In the study by Oyinbo and

Rekwot (2014) to investigate the links existing between inflationary trend, agricultural productivity and economic growth in Nigeria, their results indicated a unidirectional causality from inflationary trend to agricultural productivity.

Ali et al., (2017) examined the effect of interest rates on access to agro-credit by farmers in Kaduna State, Nigeria. Interest rate, credit awareness and farm income were determinants of credit sourced by the farmers in the study area. the lower the interest rate charged by financial institutions, the higher the volume of credit sourced by farmers and vice versa. Ukpe (2016) evaluated the effects of access to microcredit on the food security status of crop farm households in the Niger Delta. Interest rate had a negative and significant influence on access to microcredit. Ezeanyej (2014) result for assessing the impacts of interest rate deregulation in enhancing agricultural productivity in Nigeria showed that interest rate deregulation had significant and positive impact on agricultural productivity in Nigeria within the period under review.

## METHODOLOGY

### Study Area

The study was carried out in Nigeria located in the western part of Africa in the Gulf of Guinea which lies between longitudes 3° and 14° East and latitudes 4° and 14° North, has a land mass of 923,768 sq.km and known for her agro-ecological resources and diversity, capable of producing different types of nutritious and sustainable food throughout the year.

### Method of Data Collection

Secondary data consisting of annual time series covering a period of 32 years (195-2016) was used for the study. Particularly, data on the values of food production index, inflation rate, interest rate, government expenditure on agriculture and exchange rate were obtained from World Bank development indicator data base, Central Bank of Nigeria statistical Bulletin, World Factfish and National Bureau of Statistics.

### Data Analysis Techniques

Augmented Dickey Fuller test (ADF) was used for stationary test of variables. Johansen cointegration test was used to test the existence of the long run relationship, vector error correction model (VECM) model was used to analyze long and short run effects of determinants of food importation, variance decomposition was used to examine contribution of variables affecting food importation and impulse response was used to examine the response of food importation to unit shock of each variables affecting food importation.

## Models Specification:

### Augmented Dickey-Fuller test (ADF)

Following Oyinbo and Rekwot (2014) the Augmented Dickey Fuller (ADF) model with the constant term and trend was specified as

$$\Delta Y_t = \alpha_0 + \alpha_1 t + \beta Y_{t-1} + \sum_{i=1}^p \delta_i \Delta Y_{t-i} + \varepsilon_t \quad \text{---- (1)}$$

Where:

$Y$  is the value of the variable of interest (food production index, exchange rate, inflation rate government expenditure on agriculture and interest rate),  $\alpha_0$  is the constant,  $\alpha_1$  is the coefficient of the trend series,  $p$  is the lag order of the autoregressive process,  $Y_{t-1}$  is lagged value of order one of  $Y_{t-1}$  and  $\varepsilon_t$  is the error term.

### Johansen cointegration test

A linear combination of two or more  $I(1)$  series may be stationary or  $I(0)$ , in which case the series are co-integrated. The null hypothesis for the Johansen Co-integration test ( $H_0: r = 0$ ) implies that co-integration does not exist, while the alternative hypothesis ( $H_1: r > 0$ ) implies that it does. If the null for non-co-integration is rejected, the lagged residual from the co-integrating regression is imposed as the error correction term in a Vector Error Correction Model (VECM) given below as:

$$\nabla Y_t = \Pi Y_{t-1} + \sum_{i=1}^{k-1} \tau_i \nabla Y_{t-i} + u + \varepsilon_t \quad \text{----- (2)}$$

Where:

$\nabla Y_t$  = First difference of a  $(n \times i)$  vector of the  $n$  variables of interest,

$\Pi = (n \times n)$  Coefficient matrix associated with lagged values of the endogenous dependent variables,  $Y_{t-1} =$  Lagged values of  $Y_t$ ,  $\tau = (n \times (k - 1))$

Matrix of short term coefficients,

$u = (n \times 1)$  Vector of constant and

$\varepsilon_t = (n \times 1)$  Vector of White Noise Residuals

### Vector Error Correction Model (VECM)

$$\nabla \ln FPI_{t-i} = a_0 + \sum_{i=1}^p a_1 \nabla \ln GEXPA_{t-i} + \sum_{i=1}^p a_2 \nabla \ln EXCH_{t-i} + \sum_{i=1}^p a_3 \nabla \ln INF_{t-i} + \sum_{i=1}^p a_4 \nabla \ln INT_{t-i} + ECM_{t-i} + \square_t \quad \text{----- (3)}$$

Where:

$FPI_{t-i}$  = Food production index,  $GEXPA_{t-i}$  = Government expenditure on Agriculture (₦),  $EXCH_{t-i}$  = (Parity between ₦ to US Dollar),  $INF_{t-i}$  = Inflation rate,  $INT_{t-i}$  = Interest rate,  $\ln$  = Natural Logarithm,  $ECM_{t-i}$  = error correction model,  $\square_t$  = error term and

$\nabla$  = difference operator

## RESULTS AND DISCUSSION



**Stationarity Test (Unit Root Test)**

**Table 1: Unit root test (ADF TEST)**

	ADF Results				
	At level		At First difference		Decision
Variables	t-statistic	probability	t-statistic	probability	I(1)
$FPI_{t-1}$	-0.842340	0.3426	-9.212891	0.0000***	I(1)
$GEXPA_{t-1}$	-2.436748	0.0167**	-5.941655	0.0000***	I(1)
$EXCH_{t-1}$	-2.215823	0.0279**	-3.593848	0.0008***	I(1)
$INF_{t-1}$	-0.447471	0.5121	-6.055269	0.0000***	I(1)
$INT_{t-1}$	-0.384675	0.5356	-4.357985	0.0001***	I(1)

\*\*\* and \*\* indicate stationary at 1% and 5% levels of significance respectively

The result in Table 1 presents the summary of unit root tests conducted under the Augmented Dickey-Fuller (ADF) at level and first difference. The result indicates that government expenditure on agriculture (GEXPA) and exchange rate (EXCH) were stationary at level while food production index (FPI), inflation rate (INF) and interest rate (INT) were not stationary at level but were stationary at first difference at 1% level of significance respectively.

**Johansen Cointegration Test**

**Table 2: Co integration Rank Test based on Trace Statistics**

Hypothesised No. of	Eigenvalue	Max-Eigen Statistic	0.05 Critical Value	Prob**

CE(s)		
None *	0.841989	102.8216
At most 1	0.561271	47.46886
At most 2	0.348668	22.75269
At most 3	0.221606	9.890600
At most 4	0.076112	2.374935

Max-eigen value test indicates 1 cointegrating eqn(s) at the 0.05 level  
 \* denotes rejection of the hypothesis at the 0.05 level  
 \*\*MacKinnon-Haug-Michelis (1999) p-values  
 Source : Data analysis, 2017

The unrestricted cointegration test is based on the Max-Eigen Statistic at 5% level of significance. Table 2 shows that Max-Eigen Statistic value (102.82) is greater than the critical value (69.82) implying the presence of cointegration which indicates the long run relationship among variables. But in the subsequent cointegration equation, critical values are greater than the Max-Eigen Statistic implying the rejection of the null hypothesis that there is cointegration. Max-Eigen value test indicates one (1) cointegrating equations at 5% level of significance

**Determinants of Food Production Index in the Long Run**

**Table 3: Estimated Long run coefficients**

Variables	Coefficient	t-statistics
LNGEXPA(-1)	-5.774478***	-7.98590
LNINF(-1)	-5.640669***	-8.12229
LNINT(-1)	-1.254262**	-2.15669
LNEXCH(-1)	3.902457***	4.51988
C	132.0213	

\*\*\*, \*\* are significant at 1% and 5% respectively

The result of the determinants of food production index in the long run is presented in Table 3. The result shows that government expenditure on agriculture in the previous year, inflation rate in the previous year, interest rate in the previous year and exchange rate in the previous year significantly affected food production index. Specifically, the coefficients of government expenditure on agriculture (-5.77), inflation rate (-5.64) and interest rate (-1.25) were negative and significant at 1 percent and 5 percent respectively, indicating that one unit increase in government expenditure on agriculture, inflation rate



and interest rate decreased food production index by 5.77, 5.64 and 1.25 respectively in the long run. This could be due to the fact that increase in government expenditure on agriculture fall short of the Maputo resolution that government of member states of African Union (AU) allocate at least 10 percent of national budgeting resources to agriculture for the implementation of the comprehensive Africa Agricultural Development programme (CAADP) which Nigeria is a signatory. This result disagrees with that of Iganiga and Unemhilin (2011) who found that the variable of one-year period lag of federal capital agricultural expenditure on agricultural output found to be significant at 5 percent significance level is positively related to agricultural output.

Similarly, increase in inflation rate affected the prices of both consumable and non consumable farm inputs by increasing the prices of these inputs above the purchasing power of farmers. This suggests that the control measures for inflation control are not sustainable. This result agrees with that of Oyinbo and Rekwot (2014) who implied that that inflation rate proxied by the trend of inflation was significant in influencing agricultural productivity over the study period. The observed influence of inflationary trend on agricultural production was attributed to the persistent rise in the cost of farm inputs over the years leading to an increase in the cost of agricultural production activities. High interest rate reduced food production index as a result of farmers not being able to access agro-credits and other loans from banks and other lending agencies because the higher the interest rate, the lower the probability of farmers accessing credit, this will therefore reduce the financial capital necessary and required by farmers to increase and improve agricultural production. This result is in line with theoretical expectation meaning that, as interest rate increases, agricultural output will decrease, *ceteris paribus*, it is also in concordance with Udoka, Mbat and Duke (2016) who found that the relationship between interest rate and the Nigerian agricultural output was negative by the negative sign of its coefficient. It disagrees with Adofu, Abula and Audu (2010) who found that there is a positive relationship between interest rate deregulation and agricultural production. The result further disagrees with the result of Ezeanyejiri (2014) who found that there is insignificant contribution of exchange rate system to agricultural productivity.

In contrast, the coefficients of exchange rate in the previous year (3.9) is positive and significant at 1 percent indicating that a unit increase of exchange rate in the previous year increased food production index by 3.9 in the long run. This could be due to the high cost associated with importation which discouraged food importation and farmers thereby

seizing the opportunity and the advantage to cultivate more land area which will further increase agricultural production and in essence food production index. This result agrees with the findings of Adofu, Abula and Audu (2010) who found that there is a positive relationship between exchange rate deregulation and agricultural production in Nigeria between the period under review

**Determinants of Food Production Index in the Short Run**

**Table 4: Estimated Short run coefficients**

Error Correction:	D(LNFPI)	D(LNGEXPA)	D(LNINF)	D(LNINT)	D(LNEXCH)
D(LNFPI(-1))	0.549571*** [-2.68856]	-0.055734 [-0.21777]	-0.066989 [-0.31118]	0.124260 [ 0.26107]	0.074799 [ 0.73964]
D(LNGEXPA(-1))	0.136632 [ 0.69516]	-0.040747 [-0.16558]	0.466211 [ 2.25227]	0.343176 [ 0.74986]	-0.211030** [-2.17020]
D(LNINF(-1))	0.071079 [ 0.38185]	0.049667 [ 0.21311]	0.379230 [ 1.93446]	0.879393 [ 2.02891]	-0.077510 [-0.84166]
D(LNINT(-1))	-0.059095 [-0.80735]	0.023468 [ 0.25608]	0.056789 [ 0.73670]	-0.487840*** [-2.86236]	-0.022382 [-0.61808]
D(LNEXCH(-1))	0.075737 [ 0.21043]	0.299978 [ 0.66567]	0.883324 [ 2.33033]	-0.440055 [-0.52508]	-0.102509 [-0.57567]
C	-0.029848 [-0.23523]	-0.124994 [-0.78677]	0.230246 [ 1.72296]	-0.048005 [-0.16248]	-0.231817 [-3.69272]
R-squared	0.679947	0.580596	0.580575	0.597842	0.574266
Adj. R-squared	0.472854	0.309217	0.309182	0.337623	0.298792
F-statistic	3.283296	2.139427	2.139240	2.297453	2.084643

\*\*\* is significant at 1%. Values on brackets are t-values

The result of the short run estimates of determinants of food production index is presented in Table 4. The result shows that the coefficient of determination ( $R^2$ ) is 0.679 indicating that 68% of the variation of food production index in the short run is explained by food production index in the previous year, government expenditure on agriculture in the previous year, exchange rate in the previous year, interest rate in the previous year and inflation in the previous year. The result further showed that food production index in the previous year is the variable that significantly affected food production index in the short run. Specifically, the coefficients of food production index (-0.55) in the previous year was

negative and significant at 1 percent indicating that a unit increase of food production index in the previous year decreased food production index by 0.55 in the short run. This could be due to the fact that farmers reduced farming activities that results into increased food production because of the bountiful harvest recorded in the previous year. This result disagrees with the findings of Okpara (2017) and Idoko and jatto (2018) who found that increase in government expenditure on agriculture increased economic growth in Nigeria. However, the coefficients of inflation rate, interest rate and exchange rate were not significant. Therefore, they have no significant effect on food production index in the short run.

**Variance decomposition Analysis**

**Table 5: Variance decomposition Analysis**

Period	LNFPPI	LNGEPA	LNINF	LNINT	LNEXCH
5	68.87718	7.942851	6.190508	11.46085	5.528609
15	43.21802	38.02767	5.580111	7.375654	5.798546

The variance decomposition of food production index (FPI) showed that, in Nigeria, food production index (FPI) contributed to itself about 68.88% in the short run and about 43.22% in the long run period. government expenditure on agriculture (GEXPA), inflation rate (INF), interest rate (INT) and exchange rate (EXCH) accounted for 7.94%; 6.19%; 11.46% and 5.53% respectively in the short run to food production index. In the long run government expenditure on agriculture (GEXPA), inflation rate (INF), interest rate (INT) and exchange rate (EXCH) accounted for 38.03%; 5.58%; 7.38% and 5.80% respectively to food production index. This implies that among the variables used government expenditure on agriculture is the most contributing factor to food production index in both long and short run.

## CONCLUSION AND RECOMMENDATIONS

Food production index and by implication food security is a major concern of the government. Government expenditure on agriculture and exchange rate were stationary at level while food production index, inflation rate and interest rate were stationary at first difference. There was a single cointegrating equation showing that there was a long run relationship among variables. The result of the vector error correction model (VECM) revealed that in the short run, only government expenditure positively affected food production index significantly. In the long run government expenditure on agriculture, inflation rate and interest rate negatively affected food production index and exchange rate positively affected food production index.

The following were recommended based on the findings of the study:

- Government budget allocation to agriculture should meet up with the Maputo agreement, to ensure the necessary increase of food production;
- Interest rate should be regulated by the apex bank.

## REFERENCES

Abata, M. A., Kehinde, J. S. and Bolarinwa, S. A. (2012). Fiscal/Monetary Policy and Economic Growth in Nigeria: A Theoretical Exploration. *International Journal of Academic Research in Economics and Management Sciences*, 1(5):75-88.

Abdurrauf, I. B. (2015). Fiscal Policy and Economic development in Nigeria. *Journal of*

*Economics and Sustainable Development*, 6(7):1150-159

Adofu, I., Abula, M. and Audu, S. I. (2010). An Assessment of the Effects of Interest Rate Deregulation in Enhancing Agricultural Productivity in Nigeria. *Current Research Journal of Economic Theory* 2(2):82-86.

Ali, B. M., Agbo, F. U., Ukwuaba, I. C. and Chiemela, C. J. (2017). The effects of interest rates on access to agro credit by farmers in Kaduna State, Nigeria. *African Journal of Agricultural Research* 12(43): 3160-3168.

Applanaidu, S. D., Bakar, N. A. and Baharudin, A. H. (2014). An Econometric Analysis of Food Security And Related Macroeconomic Variables In Malaysia: A Vector Autoregressive Approach (VAR). A paper presented at International Agribusiness Marketing Conference (IAMC) 2013, 22-23 October 2013, Kuala Lumpur, Selangor, Malaysia. *UMK Procedia* 1 (2014) 93 – 102.

Ezeanyeji, C. I. (2014). An Assessment of the Impact of Interest Rate Deregulation in Enhancing Agricultural Productivity in Nigeria. *Journal of Economics and Sustainable Development*, 5(8):17-23.

Fan, S., Omilola, B., Rhoe, V. And Sheu, A. S. (2008). Towards a Pro-Poor Agricultural sector Growth in Nigeria. *World Journal of Agricultural Science*. 4(6):781-786.

Idoko, C. U. and Jatto, S. M. (2018). Government Expenditure on Agriculture and Economic Growth in Nigeria (1985-2015). *International Journal of Academic Research and Reflection*, 6(4):24-39.

Iganiga, B. O. and Unemhilin, D. O. (2011). **The Impact of Federal Government Agricultural Expenditure on Agricultural Output in Nigeria.** *Journal of Economics*, 2(2):81-88.

Ilaboya, I., Atikpo, E., Omofuma, F., Asekhome, F. and Umukoro, L. (2012) Causes, Effects and Way forward to Food Insecurity. *Iranica Journal of Energy and Environment*, 3:180-188.

Muftaudeen, O. O. and Hussainatu, A. (2014). Macroeconomic Policy and Agricultural Output in Nigeria: Implications for Food Security.



*American Journal of Economics*, 4(2):99-113.

Ogar, A., Nkamare, S. E. and Emori, E. G. (2014). Fiscal and Monetary Policy and its Effect on the Growth of Nigeri Economy. *European Journal of Business and Mnanagemnt*, 6(29):220-232.

Ojo, E. A. and Adebayo, P. F. (2012). Food Security in Nigeria: An Overview. *European Journal of Sustainable Development*, 1(2):199-222.

Oke, M. A. (2015). Determinants of National Food Security in Nigeria. *Journal of Economics and Sustainable Development*, 6(9):100-106

Okpara, C. S. (2017). Government Expenditure on Agriculture and Agricultural Output on Nigeria Economic Growth (1980-2015). *Middle-East Journal of Scientific Research* 25(5):1063-1079.

Olatunji, G.B., Omotesho, O.A., Ayinde, O. E. and Ayinde, K. (2010). "Determinants of Inflation in Nigeria: A Co- integration Approach". Contributed Paper presented at the Joint 3rd African Association of Agricultural Economists (AAAE) and 48th Agricultural Economists Association of South Africa (AEASA) Conference, Cape Town, South Africa, September 19-23, 2010. pp. 1-13.

Oyinbo, A. and Rekwot, G. Z. (2014). The Relationships of Inflationary Trend, Agricultural Productivity and Economic Growth in Nigeria. *CBN Journal of Applied Statistics*, 5(1): 35-47.

Sunday, B.; Ini-mfon, V.; Glory, E. and Daniel, E. (2012). Agricultural Productivity and Macro-Economic Variable Fluctuation in Nigeria", *International Journal of Economics and Finance*; Vol. 4, No. 8; Pp.114-135.

Udoka, C. O., Mbat, D. O. and Duke, S. B. (2016). The Effect of Commercial Banks' Credit on Agricultural Production in Nigeria. *Journal of Finance and Accounting*, 4(1):1-10.

Ukpe, O. U. (2016). Effects of Access to Microcredit on the Food Security Status of Crop Farm Households in Niger Delta, Nigeria. An unpublished PhD thesis submitted to the Department of Agricultural Economics, University of Nigeria, Nsukka. .

World Bank (1996). Poverty and Hunger Issues and Options for Food Security in Developing Countries. Washington, D.C pp. 12-20.

## SEED QUALITY STUDY IN PEPPER (*Capsicum annuum* Linn.) USING SEEDLING EMERGENCE AND ELECTRO-CONDUCTIVITY AS INDICES

Ibrahim<sup>1</sup>, H., Yusuf<sup>1</sup>, S.T., Adediran<sup>1\*</sup>, O.A., Muhammad<sup>1</sup>, A.N and Adewumi<sup>1</sup>, O.A.

<sup>1</sup>Department of Crop Production, Federal University of Technology, Minna.

\*Corresponding author's E Mail: [o.adediran@futminna.edu.ng](mailto:o.adediran@futminna.edu.ng) GSM: 07030596623

### ABSTRACT

An investigation was conducted in the screen house of Crop Production Department, Federal University of Technology, Minna, Niger State, Nigeria to determine the effect of two seed extraction methods (extraction of seeds from wet ripe fruits and extraction of seeds from dry fruits and two drying methods (sun and air) on seed quality of six pepper (*Capsicum annuum* L.) cultivars. The cultivars used were 'Rodo-Dan Sokoto' (RD-DSK), 'Rodo Dan-Brini-Gwari' (RD-DBG), 'Tatashe Dan Kano' (TS-DKA), 'Tatashe Dan Kaduna' (TS-DKD), 'Shombo Dan Sokoto' (SB-DSK) and Shombo Dan Guru' (SB-DGU). The study was a 2 X 2 X 6 factorial experiment subjected to the Completely Randomized Design. The seeds of the different treatment combinations were placed in open plastic containers and stored at 80% relative humidity and 35 °C for eight weeks. Seedling emergence test was conducted every-other-week (two-weekly-interval). Seeds of cultivar 'Shombo-Dan Guru' (SB-DGU) generally recorded significantly higher seedling emergence percentage, longer seedling and lower electrical conductivity (EC) and greater longevity were recorded in cultivar 'Shombo' than in the other cultivars. Seeds of cultivar 'TS-DKA' recorded significantly lower values for all parameters except EC compared to all other genotypes. Seeds extracted from wet fruits before drying maintained viability for a longer period than those from dry fruits. Shade-drying resulted in significantly higher germination than sun-drying all through the storage period except in SB-DGU. The study revealed that longevity was better maintained when seeds of different pepper cultivars were extracted from wet fruits and afterwards dried in shade except in TS-DKA in which seeds extracted from shade-dried fruits had significantly greater quality than those of its other treatment combinations. Significant interaction effects of cultivar, extraction and seed drying methods were also recorded. Seed viability, seedling emergence and length declined with age while EC increased with age.

**KEYWORDS:** Cultivar, extraction method, seedling emergence, sun- and shade-drying.

### INTRODUCTION

Pepper (*Capsicum annuum*) is a member of the Solanaceae family. About 30 species were identified under the genus *Capsicum* (Falusi, 2007). Out of these, five domesticated species (*Capsicum annuum*, *Capsicum frutescens*, *Capsicum baccatum*, *Capsicum chinense* and *Capsicum pubescens*) are mostly cultivated (Bosland, 2004). *Capsicum annuum* is the most widely cultivated both at subsistence and commercial scale worldwide (Chakradhar *et al.*, 2016). The crop is basically grown for its pungent fruits. The longevity of pepper seeds is largely determined by moisture content and storage environment. When physiologically matured seeds of pepper are freshly harvested, they are known to have high moisture content (about 40 – 50 %). This has to be reduced to safe moisture level of about 8-9 % by drying using several methods such as air-, sun- or mechanical drying for viability maintenance during storage (Sahoo, 2014). Dried seeds are prevented from the activities and development of micro-

organisms (Barua *et al.*, 2009). Most vegetable seeds tolerate desiccation to low moisture level (about 5 % MC) to enhance their storage life; the method or process of desiccation (drying) differs with crop species for effective seed conservation (Caixeta *et al.*, 2013). For instance, drying seeds of pepper cultivars too rapidly or with high air temperature will cause injury to seed (Copeland, 1976). Unlike in eggplant and tomato which are also members of the Solanaceae where seeds are mostly extracted using fermentation method, pepper seed extraction is mostly done by traditional farmers after drying of the ripened fruit in the sun (Peter *et al.*, 2014). High temperature of drying causes rapid deterioration of seeds resulting in poor seed germination, low seedling emergence and lower productivity (Peter *et al.*, 2014). Seed longevity is reduced by approximately half for every 1 % increase in moisture content or 5 °C increase in temperature. This principle suggests that seed storage life can be enhanced significantly by lowering the moisture

content to a safe level especially in tropical conditions. If drying is too slow, there is the possibility of reduction in the quality of the seeds during the process due to ageing (Ellis and Roberts, 1980). Ellis and Roberts (1980) further reported that if seeds are dried rapidly, a larger proportion may be lost due to desiccation injury. According to recent studies by Peter *et al.* (2014), delay or slow drying with high temperature above 25 °C will reduce viability significantly in orthodox seeds. The best method for safe seed drying to a low moisture content is to use seed drying chambers, seed dryers, where the relative humidity of the drying environment is kept under control (Ellis *et al.*, 1985). This is however not easily affordable even in established seed industries due to the high cost of establishing, operating and maintenance of facilities. Hence the need for low cost drying methods which are readily available and affordable to be used as alternatives to such expensive equipment among resource-poor farmers who are the major producers of this crop.

Presently, most researches have focused on the moisture content to which seed should be dried. Very little information exists on how seeds should be safely dried to obtain seeds of high quality with high performance capability over long period of storage. At the moment, there seems to be no suitable low cost method of seed drying which resource-poor farmers can adopt to achieve high quality seeds of pepper that will store well. Some researchers dried seeds following extraction from fresh fruits while others extracted seeds from dry fruits. Most farmers in Nigeria practice the latter. Seeds of different cultivars of the same species may also respond differently to the same drying method.

It is therefore necessary to determine the quality response of different cultivars to seed extraction and drying methods.

In this study, six cultivars of pepper were used to determine the effects of different seed extraction and drying methods on seedling emergence percentage, length and electro-conductivity of leachate of seeds of the different extractions and drying methods.

## METHODOLOGY

The experiment was conducted in the Crop Production laboratory and screen house of the Federal University of Technology, Gidan-Kwano campus, Minna, Nigeria (latitude 9° 22'N and longitude 6°15'E). Seeds from fruits of six (6) cultivars of pepper namely, 'Rodo Dan Sokoto'(RD-DSK), 'Rodo Dan Brini-Gwari' (RD-DBG), 'Tatashe Dan Kano' (TS-DKA), 'Tatashe Dan Kaduna' (TS-DKD), 'Shombo Dan Sokoto' (SB-DSK), 'Shombo Dan Guru' (SB-DGU) sourced from farmers in Kaduna, Kaduna State were used for the study. Fruits

of each cultivar were divided into four lots. Fruits of the first lot of each cultivar were cut open and the seeds extracted from them were washed and then sun-dried for 28 days. Seeds extracted from the second fruit lot of each cultivar were also washed but air-dried on the bench in ambient condition in the laboratory for 28 days. The fruits of the third lot were left intact and sun-dried while the fruits of the fourth lot were also kept intact but air-dried on bench in the laboratory with same duration as in lots 1 and 2. Seeds from the last two lots were later extracted from the dried fruits.

A sample of seeds of each of the extractions and drying methods was spread in open plastic plates and stored in an incubator at 35 °C and relative humidity of about 80% for 8 weeks to accelerate ageing of the seeds. Four replicates of 10 seeds each of each of the extraction and drying methods were sown into sand in plastic pots in the screen house at 0, 4 and 8 weeks after storage (WAS), using the Completely Randomized Design (CRD) method. The pots were watered just before sowing the seeds and then daily after sowing. Data were collected daily on seedling emergence percentage and seedling length at two weeks intervals. Emergence percentage (EP) was calculated using the relationship:

$$EP = \frac{Ne}{Nt} \times 100 \text{ (Kader, 2005)}$$

where, Ne is total number of emerged seedlings; Nt is total number of seeds sown.

Seedling length was measured from the root tip to the shoot apex using a ruler.

At the onset of storage (i.e 0) and at 4 and 8 WAS. 100 seeds of each treatment were weighed and then soaked in 40 ml distilled water for 24 hrs. The electrical conductivity of the soak water (leachate) was measured in duplicates using Jen-way Conductivity Meter (model- DDS-307) and the results were expressed as  $\mu\text{S cm}^{-1} \text{ g}^{-1}$  seeds (ISAT, 1995). This was done to determine changes in cell membrane integrity at different storage periods.

All the data collected were subjected to analysis of variance (ANOVA) for completely randomized design (CRD) using SAS Statistical Package 9.2. Means were separated using the Student-Newman-Keuls (SNK) test. Data in percentages were transformed to arcsin values before statistical analysis.

## RESULTS

Table 1 shows the effects of cultivar, extraction and drying methods on seedling emergence percentage (EP). The highest values of 68 and 69 % recorded for



SB-DSK and SB-DGU respectively at 0 WAS were at par and were significantly greater than those other cultivars. The value of 26% recorded in TS-DKA was significantly lower than those of all other cultivars. At 4 WAS, the highest EP (61%) recorded for SB-DGU was similar to those of SB-DSK (57%), RD-DSK (54%) and RD-DBG (56%). The 33% recorded in TS-DKA was significantly lower than those of all other accessions. The similar values of 44 and 34% recorded for SB-DSK and SB-DGU respectively at 8 WAS were significantly greater than those of other accessions. Seeds extracted from wet fruits before drying (E1) recorded significantly higher emergence percentages compared to seeds extracted from dry fruits (E2) at both 0 and 4 WAS but the values were similar at 8 WAS. Furthermore, air-drying of seeds (D2) resulted in significantly higher seedling emergence compared to sun-drying (SD) at 0 and 4 WAS while values for both drying methods were similar at 8 WAS. CxE interaction was significant at 0 and 4 WAS while CxD, ExD and CxExD interactions were significant at all storage periods.

Table 2 shows that at both 0 and 4 WAS seedling emergence percentage was significantly higher when seeds were extracted from fresh fruits before drying (C1) than when extracted from dried fruits (E2) in all cultivars except in TS-DKA.

Table 3 shows that at 0 and 4 WAS, air-drying of seeds (D2) resulted in significantly higher seedling emergence percentage than in sun-drying in all cultivars except in SB-DGU where the reverse was the case. The trend was almost the same at 8 WAS except in TS-DKA in which no significant difference was recorded between sun-dried and air-dried seeds.

Table 4 shows that drying method did not significantly influence seedling emergence percentage for seeds extracted from fresh fruits (E1) at both 0 and 8 WAS. Whereas seedling emergence percentage was significantly higher when fruits were air-dried than when sun-dried. At 4 WAS, air-drying resulted in significantly higher emergence percentages than sun-drying. The magnitude of increase from D1 and D2 was however greater (28%) when fruits were first dried before seeds were extracted from them (E2) compared to 8% when seeds were extracted prior to drying (E1).

Table 5 shows the effect of cultivar, extraction and drying methods interaction on seedling emergence percentage. When sun-drying (D1) method was used for all cultivars, seedling emergence percentage was significantly higher in E1 than in E2 extraction method at all storage periods. When air-drying (D2)

method was adopted, seedling emergence was significantly greater in E1 than E2 extraction method in TS-DKD (C4), SB-DSK (C5) and SB-DGU (C6) for all storage periods; at 0 and 4 WAS in RD-DBG (C2) and 4 WAS in RD-DSK (C1). The values for E2 were significantly greater than those of E1 seeds in TS-DKA (C3) at 0, and 4 WAS. Furthermore, the use of seeds extracted from air-dried (D2) fruits resulted in significantly greater seedling emergence compared to those extracted from sun-dried (D1) seeds in all cultivars except in SB-DGU (C6) for which the reverse was recorded.

Significant differences in electroconductivity (EC) values among the different cultivars were recorded at all storage periods. At 0 WAS, the highest EC ( $0.34 \mu\text{S cm}^{-1} \text{g}^{-1}$ ) was recorded in TS-DKA but the value was not significantly different from those of RD-DSK, RD-DBG, TS-DKD and SB-DSK. The lowest EC value ( $0.19 \mu\text{S cm}^{-1} \text{g}^{-1}$ ) recorded in SB-DGU was only significantly different from that of TS-DKA. Seeds extracted from dry fruits recorded significantly higher EC ( $0.47 \mu\text{S cm}^{-1} \text{g}^{-1}$ ) than those from wet fruit ( $0.09 \mu\text{S cm}^{-1} \text{g}^{-1}$ ). Drying method did not significantly affect EC except at 4 WAS when sun-drying resulted in a higher EC value ( $0.32 \mu\text{S cm}^{-1} \text{g}^{-1}$ ) than in the air-dried ( $0.29 \mu\text{S cm}^{-1} \text{g}^{-1}$ ). At 4 WAS, the value recorded for TS-DKA was significantly higher than all the other values; the lowest in SB-DGU ( $0.231 \mu\text{S cm}^{-1} \text{g}^{-1}$ ) was significantly different from all the others. EC was significantly higher in seeds extracted from dry fruits ( $0.54 \mu\text{S cm}^{-1} \text{g}^{-1}$ ) than in those from fresh fruits ( $0.08 \mu\text{S cm}^{-1} \text{g}^{-1}$ ). Furthermore, higher EC was recorded in sun-dried ( $0.32 \mu\text{S cm}^{-1} \text{g}^{-1}$ ) than in shade-dried ( $0.29 \mu\text{S cm}^{-1} \text{g}^{-1}$ ). At 8 WAS, the highest EC of  $0.57 \mu\text{S cm}^{-1} \text{g}^{-1}$  recorded for TS-DKD was only significantly different from the value recorded for RD-DBG which in turn was at par with those of RD-DSK, SB-DSK and SB-DGU.

At 0 WAS, significantly higher EC were recorded in seeds extracted from dry fruit than in those of wet fruits in all cultivars except in RD-DBG in which EC values for wet and dry fruit extraction methods were similar. Furthermore, whereas E1 values were similar among all cultivars, significant differences in EC values were recorded among cultivars in respect of E2. The value ( $0.62 \mu\text{S cm}^{-1} \text{g}^{-1}$ ) recorded for E2 in TS-DKA (C3) was significantly higher than those of RD-DBG (C2) and SB-DGU (C6). At 4 WAS, EC values were significantly different among cultivars when seeds were extracted from dry fruits, whereas seeds of cultivars RD-DSK (C4) and RD-DBG from wet fruits were similar in EC but were both significantly different from those of all other

cultivars. At 8 WAS, there were no significant differences among the EC values of the different cultivars when wet fruit (E1) extraction method was used. When the dry fruit (E2) extraction method was used, the highest EC of  $0.86 \mu\text{S cm}^{-1} \text{g}^{-1}$  recorded for TS-DKD was significantly different from that of RD-DBG ( $0.56 \mu\text{S cm}^{-1} \text{g}^{-1}$ ) but similar to the values recorded for the other cultivars ( $0.64\text{-}0.84 \mu\text{S cm}^{-1} \text{g}^{-1}$ ). Also the value ( $0.56 \mu\text{S cm}^{-1} \text{g}^{-1}$ ) recorded for RD-DBG was similar to those of RD-DSK, SB-DSK and SB-DGU.

At 4 WAS air-drying resulted in significantly higher EC compared to sun-drying in RD-DSK (C1), TS-DKD (C4), SB-DSK (C5) and SB-DGU (C6) while the opposite was the case in RD-DBG (C2) and TS-DKA (C3). The EC values of seeds of all cultivars were not significantly affected by drying method in all cultivars except in TS-DKA in which significantly higher EC was recorded in sun-dried seeds (D1) than in the ones air-dried (D2). Also, while air-dried seeds of all cultivars had similar EC, sun-dried seeds of TS-DKA recorded significantly higher EC than sun-dried (D1) seeds of RD-DBG.

At 0 WAS although drying method did not affect EC values significantly within each extraction method, the magnitude of reduction from sun (D1) to air-drying (D2) was greater in the wet fruit (E1) than in dry fruit (E2) extraction method. At 4 WAS, air-drying resulted in significant decline in EC than in sun-drying irrespective of extraction method. However, the decline was greater when dry fruit extraction method was used (about  $0.07 \mu\text{S}^{-1} \text{cm}^{-1} \text{g}$ ) than when wet fruit extraction method was used (about  $0.01 \mu\text{S cm}^{-1} \text{g}^{-1}$ ). At 8 WAS, drying method had no significant effect on the EC of seeds of the two extraction methods. However, whereas air-drying of seeds extracted from wet fruits resulted in an increase of about  $0.04 \mu\text{S cm}^{-1} \text{g}^{-1}$  compared to the sun-dried lot, fruits air-drying resulted in an EC decrease of about  $0.07 \mu\text{S}^{-1} \text{cm}^{-1} \text{g}$  compared to sun-drying.

At 0 WAS, drying method did not significantly affect EC values of seeds extracted from fresh fruit in all cultivars. The trend was similar in seeds extracted from dry fruits except in TS-DKA (C3) in which sun-drying resulted in significantly higher EC than air-drying. The EC value of  $0.86 \mu\text{S cm}^{-1} \text{g}^{-1}$  was significantly higher than those recorded for all other seed lots except in seed of RD-DSK (C1) extracted from sun- and air-dried fruits and those of TS-DKD (C4) and SB-DSK (C5) extracted from air-dried fruits. In RD-DSK (C1) and TS-DKD (C4), the EC values for E1D1 and E1D2 combinations were significantly lower than those of E2D1 combinations

whereas in RD-DBG (C2) and SB-DGU (C6), EC values were similar for all extraction and drying method combinations. At 4 WAS, RD-DSK (C1), TS-DKD (C4) and SB-DGU (C6) seeds extracted from fresh fruits had significantly lower EC when air-dried than when sun-dried whereas the reverse was the case in seeds extracted from dry fruits. In RD-DBG (C2) drying method did not have a significant effect on the EC values of seed extracted from fresh fruits while seeds extracted from sun-dried fruits recorded significantly higher EC than those from air-dried fruits. In TS-DKA (C3), sun-drying resulted in higher EC irrespective of the seed extraction method. The EC ( $0.92 \mu\text{S cm}^{-1} \text{g}^{-1}$ ) value recorded for this cultivar when seeds were extracted from sun-dried fruits was significantly higher than those of all other C X D X E interactions. Air-drying resulted in significantly higher EC values than when sun-drying method was adopted for SB-DSK (C5) irrespective of the extraction method used. At 8 WAS, drying method did not significantly affect EC values of seeds extracted from fresh fruits in all cultivars. The trend was almost repeated in seeds extracted from dry fruits except in TS-DKA (C3) in which sun-drying resulted in significantly higher EC than in air-drying. General increases in EC values were recorded for all cultivars, extraction and drying combinations throughout the storage period. Furthermore, TS-DKA (C3) seeds extracted from sun-dried fruits recorded the highest EC ( $0.86\text{-}1.10 \mu\text{S}^{-1} \text{cm}^{-1} \text{g}$ ) throughout the storage period.

## DISCUSSION

The significant differences in percentage seedling emergence in this study agree with other studies Hunje *et al.* (2007) likewise observed variation between two varieties of pepper. Significant variations in respect of emergence percentage in pea varieties was also reported by Jatoi *et al.* (2001) Such variations have been attributed to difference in genetic makeup of the cultivars.

Seeds extracted from wet fruits before drying were generally superior to those extracted from dry fruits in respect of the parameters evaluated. Available information seems to be non-specific as to the extraction method that should preferably be adopted for pepper. Sukprakan *et al.* (2005) and AVRDC (2005) suggested that pepper seed may be extracted from fresh fruits or fruits that have been dried in the sun for a few days. The general practice among pepper farmers in Nigeria and other developing countries of the world seems to be that of sun-drying of fruits followed by seed extraction. Savaraj *et al.* (2008) observed that wet extraction was beneficial to seedling vigour of eggplant. Rahman *et al.* (2015)



also advocated that seeds of eggplant be extracted by wet method and then shade-dried to ensure high quality.

The current study furthermore revealed that drying method did not generally affect the quality of seed that were extracted from fresh fruits before drying in the sun or shade whereas seeds from sun-dried fruits were generally of poor quality compared to shade-dried fruits. The poorer quality recorded in seeds extracted from sun-dried fruits maybe due to overheating of seeds in fruits especially in all the cultivars except SB-DGU while the moisture content of the seed is high. Contrary to this report, Hunje *et al.* (2007), Christinal and Tholkkappian (2012) and Krishnamurthy (1995) recorded better seed quality when fruits were dried in sun than those dried in the shade. The reason given was that slow-drying of seeds in the shade must have resulted in deterioration which manifested in poor field emergence. This is perhaps what happened in SB-DGU. Muthoka (2003) reported that neither sun nor shade drying were detrimental to seed quality in *Milletia leucantha*.

The increase in seedling emergence percentages with storage time especially in RD-DSK and RD-DBG in this study was probably due to loss of dormancy which is known to exist in freshly harvested seeds of most crop species and is lost after some period of storage. This is in agreement with earlier findings of Oladiran and Kortse (2002) which showed that 'Rodo' seeds were dormant at harvest and recorded improvement on germination after storage. Lee *et al.* (2002) also reported that seed storage is known to break dormancy in some species. The decline in seedling emergence percentage after attainment of maximum point in this study suggests that deterioration sets in with progress in storage. Copeland *et al.* (2001) reported that seed vigour usually decreases with time in storage.

This study further revealed significant differences in the electroconductivity (EC) of the solute leachate from seeds of different cultivars and seed handling treatments. Abreu *et al.* (2011) stated that EC test is employed to evaluate the extent of damage caused to cell membranes resulting from seed deterioration. The higher the reading, the poorer the vigour of a seed lot (Vidigal *et al.* 2011). It therefore follows that there were variations in the potential vigour of seeds of the different cultivars of pepper used in the current study prior to storage. De Carvalho *et al.* (2009) listed genotype as one of the factors capable of affecting EC results. Szemruch *et al.* (2015) reported that high oleic genotype of sunflower had higher EC values which correlated with lower germination percentage. Panobianco and Vieira (1996) and Vieira *et al.* (1999) also reported that EC varied

significantly with genotype in pea. In this study, EC values were generally significantly lower in seeds of RD-DSK (C1) and TS-DKD (C4) extracted by wet method compared to those seeds extracted by dry method in both varieties indicating that seeds from wet fruits had better cell membrane integrity and hence more vigorous. This result is contrary to that of Christinal and Tholkkappian (2012) which showed that higher EC values were obtained from the leachate of air-dried pepper seed compared to those dried in the sun. The authors are of the opinion that slow drying was responsible for the poor quality of air-dried seeds. The increase in EC values as storage progressed in the current study is in agreement with the work of Mirdad *et al.* (2006) and Demir *et al.* (2008) in respect of cabbage seeds subjected to controlled deterioration, which is an indication of increasing loss of membrane integrity with increase in storage. Maximum electrical conductivity coincided with the lowest seedling emergence while lower EC values were recorded when seed vigour was high. Vieira *et al.* (1999) also reported that higher EC value was an indicator of lower vigour, due to an increase in membrane permeability of lower vigour seeds.

#### **CONCLUSION AND RECOMMENDATIONS**

It is concluded that seeds of SB-DSK and SB-DGU performed better than those of RD-DSK and RD-DBG which were in turn better than those of TS-DKA and TS-DKD. Seeds extracted from wet fruits prior to drying recorded better seedling emergence than those extracted from dry fruits in all cultivars except in TS-DKA where seed extracted from air-dried fruits were of better quality than those extracted from wet fruits (irrespective of drying method) and those extracted from sun-dried fruits. Also, seeds extracted from fruits prior to drying recorded lower EC than those from dried fruits. Seeds extracted from sun-dried fruits of TS-DKA recorded the highest EC values. The study also revealed that the use of seeds from air-dried fruits resulted in seedling emergence than those from sun-dried fruits in all cultivars except SB-DGU. Seedling emergence percentage declined in all cultivars after some period of storage irrespective of seed extraction and drying methods. Electroconductivity of seed leachate increased with storage period.

It is recommended from this study that to obtain high seedling emergence percentage, pepper seeds should be extracted from wet fruits and then dried in the sun or shade.



**Table 1: Effects of cultivar, drying method and extraction method on the emergence percentage of *Capsicum annuum* seeds.**

Fruit/Level	Storage period (weeks)		
	0	4	8
<b>Cultivar</b>			
RD-DSK (C1)	47b4s	54ab	21b
RD-DBG (C2)	46b	56ab	23b
TS-DKA (C3)	26c	33c	14b
TS-DKD (C4)	49b	46b	22b
SB-DSK (C5)	68a	57a	44a
SB-DGU (C6)	69a	61a	34a
<b>Extraction method (E)</b>			
Wet fruit (E1)	63a	66a	23a
Dry fruit(E2)	39b	37b	28a
<b>Drying method (D)</b>			
Sun (D1)	44b	42b	24a
Air (D2)	58a	60a	28a
<b>Interaction</b>			
C X E	*	*	NS
C X D	*	*	*
E X D	*	*	*
C X E X D	*	*	*

Values followed by same letter under each factor and storage period are not significantly different (p=0.05).

\*= Significant; NS= non-significant

**Table 2: Interaction effect of cultivar and extraction method (wet fruit-E1 and dry fruit-E2) on seedling emergence percentage.**

Cultivar x Extraction	Storage period (weeks)	
	0	4
C1 E1	60c	71bc
C1 E2	35e	36ef
C2 E1	63bc	73b
C2 E2	29f	40e
C3 E1	25f	31g
C3 E2	28f	34fg
C4 E1	65b	68c
C4 E2	34e	25h
C5 E1	83a	74ab
C5 E2	53d	40e
C6 E1	83a	78a
C6 E2	55d	45d

Values followed by the same letter under each storage period are not significantly different (p=0.05).

**Table 3: Interaction effect of cultivar and drying method (sun-drying-D1 and air-drying-D2) on seedling emergence percentage.**

Cultivar X Drying	Storage period (week)		
	0	4	8
C1 D1	35fg	35g	13g
C1 D2	60cd	73b	30c
C2 D1	34g	43f	18ef
C2 D2	58d	70ab	28cd
C3 D1	14h	20h	13g
C3 D2	39ef	45f	15fg
C4 D1	43e	36g	20e
C4 D2	56d	56d	24d
C5 D1	53c	51e	41b
C5 D2	73b	79a	46a
C6 D1	78a	73c	43b
C6 D2	60cd	58d	25d

Values followed by the same letter under each storage period are not significantly different (p=0.05).

**Table 4: Interaction effect of extraction (wet fruit-E1 and dry fruit-E2) and drying method (sun-drying-D1 and shade-drying-D2) on seedling emergence.**

Extraction X Drying	Storage period (weeks)		
	0	4	8
E1 D1	63a	62b	34a
E1 D2	63a	70a	31a
E2 D1	25c	23d	15c
E2 D2	53b	51c	25b

Values followed by the same letter under each storage period are not significantly different (p=0.05).

**Table 5. Interaction effect of cultivar, extraction (wet fruit-E1 and dry fruit-E2) and drying method (sun-drying-D1 and air-drying-D2) on seedling emergence percentage of *Capsicum annuum* seeds at 0-8 weeks of storage (WAS)**

Cultivar X Extraction X Drying	Storage period (weeks)		
	0	4	8
C1E1D1	63g	63de	25f
C1E1D2	58h	80a	18g
C1E2D1	7.5m	8k	0j
C1E2D2	63fg	65d	43bc
C2E1D1	60gh	70c	30e
C2E1D2	65ef	75b	25f

C2E2D1	7.5m	15j	5i
C2E2D2	50i	65d	30e
C3E1D1	20l	30h	18g
C3E1D2	30k	33h	15gh
C3E2D1	7.5m	10k	8i
C3E2D2	58i	58fg	15gh
C4E1D1	68e	55g	35d
C4E1D2	63fg	80a	35d
C4E2D1	18l	18j	5i
C4E2D2	50i	33h	13h
C5E1D1	88a	78ab	58a
C5E1D2	78c	70c	58a
C5E2D1	38j	25i	25f
C5E2D2	68e	55o	35d
C6E1D1	83b	75b	40c
C6E1D2	83b	80a	35d
C6E2D1	73d	60ef	45b
C6E2D2	38j	30h	15gh

Values followed by the same letter under each storage period are not significantly different (p=0.05).

**Table 6: Effect of cultivar, drying method and extraction method on electro-conductivity ( $\mu\text{S cm}^{-1} \text{g}^{-1}$ ) of *Capsicum annuum* seed leachate at 0, 4 and 8 WAS**

	Storage period (weeks)		
	0	4	8
<b>Cultivar (C)</b>			
RD-DSK (C1)	0.32ab	0.36b	0.50ab
RD-DBG (C2)	0.29ab	0.25e	0.41b
TS-DKA (C3)	0.34a	0.37a	0.55a
TS-DKD (C4)	0.28ab	0.33c	0.57a
SB-DSK (C5)	0.25ab	0.29d	0.50ab
SB-DGU (C6)	0.19b	0.23f	0.46ab
<b>Extraction Method (E)</b>			
Wet Fruit (E1)	0.09b	0.08b	0.27b
Dry Fruit (E2)	0.47a	0.54a	0.73a
<b>Drying Method (D)</b>			
Sun (D1)	0.31a	0.32a	0.51a
Air (D2)	0.25a	0.29b	0.49a
<b>Interaction</b>			
C x E	*	*	*
C x D	*	*	*
E x D	N.S	*	*
C x E x D	*	*	*

**Table 7: Interaction effect of cultivar and extraction method on electro-conductivity ( $\mu\text{S cm}^{-1} \text{g}^{-1}$ ) of *Capsicum annuum* seed leachate at 0, 4 and 8 WAS**

	Storage period (weeks)		
--	------------------------	--	--

Cultivar Extraction	X	Storage period (weeks)		
		0	4	8
C1 E1		0.07e	0.09g	0.29c
C1 E2		0.57ab	0.64b	0.71ab
C2 E1		0.22de	0.08g	0.25c
C2 E2		0.37bcd	0.42e	0.56b
C3 E1		0.07e	0.07h	0.26c
C3 E2		0.62a	0.67a	0.84a
C4 E1		0.05e	0.07h	0.28c
C4 E2		0.50abc	0.58c	0.86a
C5 E1		0.06e	0.07h	0.27c
C5 E2		0.44abcd	0.51d	0.74ab
C6 E1		0.05e	0.06k	0.27c
C6 E2		0.33cd	0.40f	0.64ab

Values followed by the same letter under each storage period are not significantly different (p=0.05).

**Table 8: Interaction effect of cultivar and drying method on electro-conductivity ( $\mu\text{S}^{-1}\text{cm}^{-1}\text{g}$ ) of *Capsicum annuum* seed leachate at 0, 4 and 8 WAS**

Cultivar Drying	X	Storage period (weeks)		
		0	4	8
C1 D1		0.32ab	0.35c	0.45ab
C1 D2		0.32ab	0.36b	0.55ab
C2 D1		0.39ab	0.28g	0.39b
C2 D2		0.20b	0.22k	0.42b
C3 D1		0.47a	0.45a	0.68a
C3 D2		0.22b	0.24j	0.42b
C4 D1		0.25ab	0.32e	0.59ab
C4 D2		0.30ab	0.34d	0.55ab
C5 D1		0.21b	0.27h	0.48ab
C5 D2		0.30ab	0.31f	0.53ab
C6 D1		0.19b	0.22k	0.46ab
C6 D2		0.19b	0.24l	0.46ab

Values followed by the same letter under each storage period are not significantly different (p=0.05).

**Table 9. Interaction effect of extraction and drying method on electro-conductivity ( $\mu\text{S}^{-1}\text{cm}^{-1}\text{g}$ ) of *Capsicum annuum* seed leachate at 0, 4 and 8 WAS**

Extraction Drying	X	Storage period (weeks)		
		0	4	8
E1 D1		0.12b	0.08c	0.25b
E1 D2		0.06b	0.07d	0.29b
E2 D1		0.49a	0.57a	0.76a
E2 D2		0.45a	0.50b	0.69a

Values followed by the same letter under each storage period are not significantly different ( $p=0.05$ ).

**Table 10: Interaction effect of cultivar, extraction and drying method on electro-conductivity ( $\mu\text{S}^{-1}\text{cm}^{-1}\text{g}$ ) of *Capsicum annuum* seed leachate at 0, 4 and 8 WAS.**

Cultivar X Extraction X Drying	Storage period (weeks)		
	0	4	8
C1 E1 D1	0.10c	0.08c	0.25b
C1 E1 D2	0.04c	0.07d	0.29b
C1 E2 D1	0.54ab	0.57a	0.76a
C1 E2 D2	0.59ab	0.50b	0.69a
C2 E1 D1	0.39bc	0.08c	0.25b
C2 E1 D2	0.05c	0.07d	0.29b
C2 E2 D1	0.39bc	0.57a	0.76a
C2 E2 D2	0.35bc	0.50b	0.69a
C3 E1 D1	0.08c	0.08c	0.25b
C3 E1 D2	0.06c	0.07d	0.29b
C3 E2 D1	0.86a	0.57a	0.76a
C3 E2 D2	0.37bc	0.50b	0.69a
C4 E1 D1	0.04c	0.08c	0.25b
C4 E1 D2	0.06c	0.07d	0.29b
C4 E2 D1	0.52b	0.57a	0.76a
C4 E2 D2	0.53ab	0.50b	0.69a
C5 E1 D1	0.05c	0.08c	0.25b
C5 E1 D2	0.07c	0.07d	0.29b
C5 E2 D1	0.37bc	0.57a	0.76a
C5 E2 D2	0.52ab	0.50b	0.69a
C6 E1 D1	0.06c	0.08c	0.25b
C6 E1 D2	0.05c	0.07d	0.29b
C6 E2 D1	0.32bc	0.57a	0.76a
C6 E2 D2	0.33bc	0.50b	0.69a

Values followed by the same letter under each storage period are not significantly different ( $p=0.05$ ).

**REFERENCES**

Abreu, L. A. S., Carvalho M. L. M, Pinto C. A. G., Kataoka V. Y. (2011). Electrical conductivity test to evaluate quality of sunflower seeds at different temperatures. *Revista Brasileira de Sementes*, 33, 637-644.

Ado, S.G. (1999). Potentials of native and exotic pepper germplasm in Nigeria. An exploitable resource in the next millennium. Commemorative publication on the Silver Jubilee of the *Genetic Society of Nigeria*. 22-36.

Barua, H., Rahman, M.M and Masud, M.M (2009). Effect of storage containers, environment at different storage period on the quality of chilli seed. *International Journal on sustainable Crop Production*, 4(4): 28-32.

Bosland, P.W. (2004). Chillies, history , cultivation and uses: In Charalambous .C. (Editors) Species, herbx and edible fungi. *Elsevier Science*, New York, 347-366.

Chakrabarti, P., Laxmi Prasad, S., Ananda, C.S and Sahoo, K.M. (2006). Studying the effect of different fruit and seed drying methods on seed quality of several different genotypes of chilli (*Capsicum annuum* L.). *International Journal of Science, Environment and Technology*, 5(5): 3262-3270.

Christina, M. and Thokomian, P. (2012). Seed Quality in Chilli Influenced by the Different Types of Drying Methods. *International Journal of Research in Scientific Research*, 3(9), 766-770.

Copeland, L. O. and McDonald, M. B. (2001). Principles of Seed Science and Technology (4th edition.) New York: Chapman & Hall, 467.

De Carvalho, L. F. C, Saito, M. S., Reis, D. O, F. S., Dias and Moreira, M. A. (2009). Influence of soaking temperature of soybean seeds in the electrical conductivity test to evaluate phytochemical quality. *Rev. Bras. De Sementes*, 31, 9-17.

Delouche, J. C., Baskin, C. C. (1973). Accelerated aging techniques for predicting the relative storability of seed lots. *Seed Science and Technology*, 1, 427-452.



- Demir, I., Mavi, K., Kenanogul, B. B., and Matthew S. (2008). Prediction of germination and vigour in naturally aged commercially available seedling of cabbage (*Brassica oleracea capitata*) using the bulk conductivity method. *Seed Science Technology*, 36, 509-523.
- Ellis, R.H., and Roberts, E.H. (1980). Improved equations for prediction of seed longevity. *Annals of Botany*, 45: 13-30.
- Ellis, R.H., and Hong, T.D and Roberts, E.H. (1985). Handbook of seed technology for gene banks. Volume 1. Principle and methodology, *International Board for Plant Genetics Resources Rome, Italy Technology*, 41(5): 479-486.
- Falusi, O. A., and Morakinyo, J. A. (2007). Pollen and hybridization studies in some Nigerian species of peppers. *Nigeria Journal of Technology of Education*, 1(2): 40-43.
- Hunje Ravi, B. S. Vyakarnahal and R. C. Jagadeesh (2007). Influence of Drying Methods of Fruits on Seed Quality in Chilli (*Capsicum annum L.*). *Karnataka Journal for Agricultural Science*. 20(2), 269-271
- Jatoi, S. A., Afzal, M., Nasim, S. and Anwer, R. (2001). Seed deterioration study in pea using accelerated ageing techniques. *Pakistan Journal of Biological Sciences*, 4(12), 1490-1494.
- Kader, A. A. (2005). Produce Facts. Papaya: Recommendations for maintaining postharvest quality. Postharvest Technology Research and Information Centre, Department of Pomology, University of California, Davis.
- Krishnamurthy, V. (1995). Effect of harvesting stages, drying, seed extraction and size grading on seed yield and quality in chilli (*Capsicum annum L.*). M.Sc. (Agriculture). Thesis, University of Agricultural Sciences, Bangalore.
- Lee, S. Y., Lee, J. H. and Kwon, T. O. (2002). Varietal differences in seed germination and seedling vigour of Korean rice varieties following dry heat treatment. *Seed Science and Technology*, 30, 311-321.
- McLeod, M. T., Sheidon, I. G. and Eshbaugh, W. H. (1982). Early evolution of chilli peppers. *Economy Botanica*, 36, 361-368.
- Mirdad, Z., Powell, A. A. (2006). Prediction of germination in artificially aged seeds of *Brassica* species using the bulk conductivity test. *Seed Science Technology*, 34, 273-281.
- Muthoka, P. N., Probert, R. J. and Coomber, S. A. (2003). Seed quality studies in kenyan Shrub *Millettia leucantha*. In Smith R. D., et al. (eds). Seed Conservation turning science into practice. *The Royal Botanic Gardens, Kew*. 7, 135-149.
- Panabianco, M., and Vieira, R. D. (1996). Electrical conductivity of soybean soaked seed and the effect of genotype. *Pesquisa agropecaria Agropecaria Brasileira*, 31 (9), 621-627.
- Peter, J.N., Keshavulu, K., Manohar, R., Chandra, K.S.R and Amtul, R. (2014). Post-harvest drying of tomato (*Lycopersicon esculentum* Mill) seeds to ultra low moisture safe for storage using desiccant (Zeolite) beads and their effects on seed quality. *American Journal of Research Communication*, 2(4): 74-83.
- Rahman, M. B., Hossain, M. M., Haque, M. M., Ivy, N. A., Ahmad, S. (2015). Physiological Quality of Eggplant Seed as Influenced By Extraction Method. *Advanced Crop Science Technology* S1: 005 doi:10.4172/2329-8863.S1-005
- Sahoo, L.P. (2014). Fruits and seed development pattern and seed storability of some genotypes of chilli (*Capsicum annum L.*). PhD thesis, Department of seed Science and Technology, Orissa University of Agriculture and Technology, Bhubaneswar, Odisha, India. Pp: 225.
- Savaraj, N., Pandravada, S. R., Kamala, V., Unil, N., and Abraham, B. (2008). Efficacy of extraction methods on seed storage in eggplant (*Solanum melogena L.*). *Advanced Crop Science Technology*, 2, 56-62

Serrano-Martinez, A., Fortea, F. M., Del Amor, F.M. and Nufiez-Delicado. E. (2008). *Food Chemistry*. 107,193-199

Sukprakarn, S., Juntakool S., Huang R., and Kallo T. (2005). Saving your ouw vegetable seeds. A guide for farmers. AVRDC publication number 65-647. AVRDC. The World Vegetable Center, Shanhua, Taiwan. 25.

Szemruch, C., Longo, D. O., Ferrari, L., Renreria, S., Murica, M., Cantamutto, M. and Rondanini D. (2015). Ranges of vigour on the electrical conductivity test in dehulled sunflower seeds. *Research Journal of Seed Science* 8, (1)12-21.

Thomsen, K., and Stubsgaard, F. (1998) Lecture Note C-5A, Danida Forest Seed Centre, Humlebaek, Denmark,.

Vidigal, D. S., Dias, D. C. F. S., Naveira, D. S. P., Rocha, F. B. and Bhering, M. C. (2006). Qualidade fisiologicas e enzimaticas durante a maturacao de sementes de pimenta (*Capsicum annuum* L.). *Revista Brasileira de Sementes* 28, 87-93.

Vieira, R. D., Paiva-aguero, J. A. and Perecin, D. (1996) Electrical conductivity and field performance of soybean seeds. *Seed Technology*,21,15-24.

Vieira, R. D., Paiva-aguero, J. A., Perecin, D., and Bittencourt, S. R. M. (1999) Correlation of electrical conductivity and other vigor tests with field emergence of soybean seedlings.

Zhang Zhang A. Lu, and W. G. D'arcy, (2002) "*Capsicum annuum* Linnaeus, Special Plant, *Flora of China*, 17:313-313.

## GROWTH AND YIELD RESPONSE OF MAIZE (*Zea mays* L.) VARIETIES TO DIFFERENT LEVELS OF NITROGEN FERTILIZER APPLICATION IN MINNA, NIGERIA.

Saidu<sup>1</sup>\*A., Mamudu,<sup>1</sup>A.Y., Oladele<sup>1</sup> E. R. <sup>2</sup>Ndagana Muhammed Kolo

<sup>1</sup>Department of Crop Production, Federal University of Technology Minna, Nigeria.

<sup>2</sup>National Agricultural Extension and Research Liaison Services, Department of Crop and Forestry, Ahmadu Bello University (NAERLS/ABU) Zaria, Nigeria.

\*Correspondence author e-mail: saiduadamu08@yahoo.com; [saidu.adamu@futminna.edu.ng](mailto:saidu.adamu@futminna.edu.ng) GSM: 07036683435

### ABSTRACT

Nitrogen (N) management in maize production is one of the main concerns since it is the most important and primary nutrient for growth and development of the crop. Field trial was carried out at Teaching and Research Farm of Federal University of Technology Minna, Gidan Kwanoto to determine the growth and yield response of maize varieties to different levels of nitrogen fertilizer application.

The experiment was laid out in 3×4 factorial in a Randomised Complete Block Design (RCBD) and replicated three times. Three varieties of maize used were OBA SUPER, SAMMAZ 17 and KAMPA 6. The treatments were four application levels of Nitrogen fertilizer namely; control (no application), 20kg/ha, 60kg/ha, and 100kg/ha. Five stands of maize were randomly selected and tagged from each plot for data collection. Data collected were plant height, number of leaves, days to 50% tasselling, number of cobs, cob length, cob weight, and grain weight. Data collected were subjected to analysis of variance and means were separated using Duncan Multiple Range Test at 5% level of probability. Result obtained showed that SAMMAZ 27, KAMPA 6 varieties and application of nitrogen fertilizer (N) at 100 kg/ha produced optimum growth and yield of maize. The application of nitrogen fertilizer at 100 kg/ha and cultivation of SAMMAZ 27 and KAMPA 6 maize varieties are hereby recommended for farmers in the study area for optimum growth and yield of maize.

**KEYWORDS:** Nitrogen fertilizer, Maize and levels

### INTRODUCTION

Maize can grow on a wide range of soils though it performs best in well drained aerated loam or silty loams or alluvial soils with a pH of 5.5-7. It can grow in a wide range of agro-ecological zones.

Nitrogen is vital plant nutrient and a major growth and yield determining factor required for maize production. It makes up to 4% of dry matter of the plants, and is a component of protein, nucleic acids and many other compounds essential for plant growth processes which includes chlorophyll and enzymes (Tisdale *et al.*, 1999). Its availability in sufficient quantity throughout the growing season is essential for optimum maize growth. The optimal amounts of other essential elements such as phosphorous in the soil cannot be utilised efficiently, if N is deficient in plants. Several researchers (Jehant *et al.*, 2006; Festus *et al.*, 2007; Hafiz *et al.*, 2011; and Mohammed and Hassan, 2011) ascribed lower yield in maize when the crop was subjected to a high dose of N, while time of N application improved N uptake and protects the soil environment. Similarly, at low N supply, crop growth rate slows down causing reproductive structures to decline, and this results in lower maize grain yield and its components (Ronald *et al.*, 2005; Hafiz *et al.*, 2011; Waga 2011;

Mohammed and Awale, 2013; Merkebu and Ketema, 2013). Time of N application at appropriate crop growth stage is also another main focus to enhance N use efficiency and increase maize productivity. Among several functions, nitrogen plays a key role on plants metabolism. This element takes part in different metabolic pathways of great importance to plants (Sangoiet *al.*, 2008). Among the crops of agronomic interest, maize express nutritional dependence, especially of nitrogen (Cancellier *et al.*, 2011).

Ferreira *et al.*, (2001) concluded that nitrogen fertilization improved grain quality increasing protein and mineral nutrients content, intervening positively in the number of ears per plant, weight of ears, as the mass of a thousand seeds increased according to the nitrogen doses.

### MATERIALS AND METHODS

Field trial was conducted at the Teaching and Research Farm of Federal University of Technology Minna, Gidan Kwano Minna ( latitude 09° 37.86' N and longitude 06° 33.28' E in sub-humid tropical climate, southern Guinea savanna of Nigeria. Minna has a mean annual rainfall of about 1284 mm and a distinct dry season of 6 months duration occurring



from November to April. The maximum temperature remain high throughout at about 33.5 °C , particularly in March and June. Soil samples were collected from twelve points along diagonal transects at the depth of 0-15 cm at the Teaching and Research Farm before sowing, surface soil sample were bulked together to form a composite sample. The soil samples were air-dried, gently crushed and passed through 2-mm sieve. The processed soil samples were analysed for some physical and chemical properties following the procedures outlined by Agbime, (1995). The plot size was 40 m ×12 m which was cleared and prepared manually. The experimental site was divided into 36 plots. Weeding was carried out at regular interval. The treatment consist of four levels (20kg/ha, 40kg/ha, 100kg/ha and control) of nitrogen fertilizer application, and three varieties (OBA SUPER, SAMMAZ 27 and KAMPA 6) of maize. The design of the experiment was 3×4 factorial arrangement fitted to Randomized Complete Block Design and replicated three times. Data collected were plant height, number of leaves, days to 50% tasselling, number of cobs, cob length, cob weight, and grain weight. Data collected were subjected to analysis of variance and means were separated using Duncan Multiple Range Test at 5% level of probability.

## RESULTS AND DISCUSSION

The results of some physical and chemical properties of the soil prior to sowing are presented in Table 1. The results revealed that the soil texture of the experimental site was sandy clay loam, slightly acidic in water which make it suitable for plant growth because of the availability of plant nutrients for plant uptake at P<sup>H</sup> 5.5-6.5 (Brady and Weil, 2002). The result also showed that soil was also low in inorganic carbon, available phosphorus and medium in total nitrogen.

Analysis of data revealed that nitrogen levels had no significant ( $P \geq 0.05$ ) effect on number of plant leaves, however maize variety had significant effect on number of leaves of plant Table 2. The effect of levels of nitrogen fertilizer application on number of leaves was significant ( $P \leq 0.05$ ) at 3 and 9 weeks after sowing (WAS) on maize variety. The maize variety SAMMAZ 27 recorded highest number of leaves (6.42) while lowest (5.92) was observed in KAMPA 6 at 3 weeks after sowing. The result obtained also indicated that maize varieties did not show any significant ( $P \geq 0.05$ ) differences in the number of levels at 6 weeks after sowing. However, at 9 weeks after sowing (WAS) significant ( $P \leq 0.05$ ) effect was recorded in the number of leaves where highest number of leaves (12.17) was observed in OBA SUPER 1. This result is in line with the work of Badr and Authman (2006) who reported that increasing nitrogen fertilizer rate from zero up to 250

kg N/ha significantly increase the number of leaves. The result of the analysis showed that nitrogen levels had no significant ( $P \geq 0.05$ ) effect on days to 50% tasselling, days to 50% silking, and number of cobs. However, maize variety had significant ( $P \leq 0.05$ ) effect on days to 50% tasselling and days to 50% silking (Table 3). The result revealed that OBA SUPER 1 recorded highest number of days to 50% tasseling (57.00), while lowest was observed in SAMMAZ (55.75). This result agreed with the findings of Hafiz *et al.* (2011) who reported that maize crop took 50 days for tasseling and 103 days for maturity when N was applied at 130 kg/ha under rain-fed condition. Jehan *et al.* (2006), Mahamed and Awale (2013) also reported that days to tasseling and maturity were significantly affected by the successive additions of N, and with increasing rates of N fertilizer, the crop took a shorter period to mature than the treatments receiving either no or lower rates of N.

The results of the significant variety ×N level interaction effects observed at four levels of N on cob length, presented on Table 4 revealed that KAMPA 6 recorded highest cob length (14.00) where N fertilizer was not applied while lowest cob length (8.90) was obtained in SAMMAZ 27 . The results also showed that KAMPA 6 recorded highest cob length when 20 kg N/ha (14.00), 60 kg N/ha (14.47) and 100 kg (13.33) N/ha were applied respectively while OBASUPER 1 and SAMMAZ 27 recorded lowest cob length.

The interaction effect of Nitrogen fertilizer levels and maize varieties significantly affected the cob length. This implies that the responses of different maize varieties to levels of N fertilizer were different. Le Gouis *et al.* 2000 confirmed that there is genetic variability for grain yield at low N level and that the genotype ×N level interaction is significant.

The results of the significant interactive effects of maize variety and N levels presented in Table 5 show that there was significant different ( $P \leq 0.05$ ) in the cob length among the maize varieties where nitrogen was not applied. The results of the analysis revealed that OBASUPER 1 recorded highest cob weight (0.54) while lowest (0.19) was observed SAMMAZ 27. However, KAMPA 6 recorded highest cob weight when 20 kg N/ha and 60 kg N/ha were applied respectively, while application of 100 kg N/ha resulted in highest cob weight in SAMMAZ 27. This result is similar to experiment conducted

by Ronald *et al.* 2005 who observed that grain yield is the end result of many complex morphological and physiological processes occurring during the growth and development of the crop

The interactive effects of nitrogen fertilizer levels on maize grain weight shown on Table 6 revealed that significant ( $P \leq 0.05$ ) different was recorded among maize varieties where N fertilizer was not applied. OBASUPER 1 recorded highest grain weight (0.41) while SAMMAZ 27 recorded lowest (0.39) grain weight. The application of 20 kg N/ha and 60 kg N/ha significantly affected the maize grain weight among the varieties, in which KAMPA 6 recorded highest grain weight while lowest grain weight was recorded in SAMMAZ 27. However, application of 100 kg N/ha resulted in highest grain weight in SAMMAZ 27 and lowest was in OBASUPER 1. This results are in line with the research conducted by Gul *et al.* 2015 who reported that maize grain yield was linearly influenced by nitrogen levels applied. Bashir

(2012), Okumura *et al.* (2011), Depariset *al.* (2007), Cruz *et al.* (2008) and Bastoset *al.* (2008) showed also linear behaviour linked to yield in maize induced by increase in nitrogen level.

## CONCLUSIONS

Nitrogen fertility of soil has a major role in maintaining and maximizing the productivity of the maize. However, a number of factors limit yields even when N fertility is optimal. The result obtained from this study show that significant differences were observed for the growth parameters, as well as grain yield. Maize growth parameters such as leaves and plant height increased significantly with increase in nitrogen level. Maize yield characters like cob length, cob weight and grain weight also increase significantly with increase in N level. Further studies may continue along the lines of investigating the optimum application levels of N fertilizer which gives the best results.

**Table 1** Some physical and chemical properties of the soil before sowing

Parameters	Values
Sand ( $\text{g kg}^{-1}$ )	752
Silt ( $\text{g kg}^{-1}$ )	15
Clay ( $\text{g kg}^{-1}$ )	232
Textural classes	Sandy clay loam
pH in $\text{H}_2\text{O}$ (1:2.5)	6.32
Total Nitrogen ( $\text{g kg}^{-1}$ )	0.20
Available P ( $\text{mg kg}^{-1}$ )	8.00
Organic Carbon ( $\text{g kg}^{-1}$ )	7.20
Exchangeable Cation ( $\text{cmol kg}^{-1}$ )	
$\text{Mg}^{2+}$	1.02
$\text{Ca}^{2+}$	2.14
$\text{K}^{+}$	0.41
$\text{Na}^{+}$	0.27
Exchangeable Acidity ( $\text{cmol kg}^{-1}$ )	0.01
ECEC ( $\text{cmol kg}^{-1}$ )	3.90

**Table 2** Effects of nitrogen fertilizer levels on the number of leaves on three varieties of maize.

Treatments Fertilizer (F)	Numbers of Leaves		
	3WAS	6WAS	9WAS
Control	6.22a	11.22a	11.56a
20kg N/ha	6.00a	11.22a	11.67a
60kg N/ha	6.11a	10.89a	11.78a
100kg N/ha	6.22a	11.11a	12.00a
LSD	0.49	0.89	0.65
<b>Variety (V)</b>			
OBASUPER 1	6.08a	10.75a	12.17a
SAMMAZ 27	6.42a	11.50a	11.17b
KAMPA 6	5.92b	11.08a	11.92a
LSD	0.42	0.77	0.56
Interaction (FXV)	NS	NS	NS

Means with the same letter (s) in a column of a treatment group are not significantly different at 5 % level of probability.

NS= Indicate not significantly different at  $p > 0.05$  WAS= weeks after sowing

**Table 3 Effects of Nitrogen fertilizer (N) on days to 50% tasseling and days to 50% silking and number of cobs per plot.**

<b>Treatments</b>			
<b>Fertilizer (F)</b>	<b>Days to 50% Tasseling</b>	<b>Days to 50% silking</b>	<b>Number of cobs per plot</b>
Control	53.89a	64.56a	5.00a
20kg N/ha	54.89a	63.67a	5.00a
60kg N/ha	55.33a	63.11a	5.00a
100kg N/ha	54.00a	61.78a	5.00a
LSD	2.31	4.23	0
<b>Variety (V)</b>			
OBASUPER 1	57.00a	67.83a	5.00a
SAMMAZ 27	50.83b	58.67c	5.00a
KAMPA 6	55.75a	63.33b	5.00a
LSD	2.00	3.66	0
Interaction (FXV)	NS	NS	NS

Means with the same letter (s) in a column of a treatment group are not significantly different at 5 % level of probability.

NS= Indicate not significantly different at  $p > 0.05$

**Table 4 Interactive effects of Nitrogen fertilizer (N) rates and maize varieties on cob length(cm).**

<b>Variety</b>	<b>Fertilizer</b>			
	<b>control</b>	<b>20 kg N/ha</b>	<b>60 kg N/ha</b>	<b>100 kg N/ha</b>
OBASUPER 1	12.93ab	12.27ab	11.10bcd	9.20d
SAMMAZ 27	8.90b	9.40cd	11.07bcd	12.83ab
KAMPA 6	14.00ab	14.00ab	14.47a	13.33ab
S.E±		1.04		

Means with the same letter (s) in a column or row of a treatment group are not significantly different at 5 % level of probability.

SE± = Standard Error

**Table 5: Interactive effects of Nitrogen fertilizer (N) rates and maize varieties on cob weight(kg)**

<b>Variety</b>	<b>Fertilizer</b>			
	<b>control</b>	<b>20 kg N/ha</b>	<b>60 kg N/ha</b>	<b>100 kg N/ha</b>
OBASUPER 1	0.54a	0.45abc	0.33bcd	0.19d
SAMMAZ 27	0.19d	0.25cd	0.37abcd	0.53ab
KAMPA 6	0.52ab	0.52ab	0.52ab	0.51ab
S.E±		0.073		

Means with the same letter (s) in a column or row of a treatment group are not significantly different at 5 % level of probability.

SE± = Standard Error



**Table6: Interactive effects of Nitrogen fertilizer rates and maize varieties on grain weight(kg).**

Variety	Fertilizer			
	control	20 kg N/ha	60 kg N/ha	100 kg N/ha
OBASUPER 1	0.410a	0.33abc	0.22bcd	0.13d
SAMMAZ 27	0.150d	0.19cd	0.17cd	0.43a
KAMPA 6	0.39a	0.38ab	0.36ab	0.37ab
S.E±		0.059		

Means with the same letter (s) in a column or row of a treatment group are not significantly different at 5 % level of probability.

SE± = Standard Error

## REFERENCES

- Agbenin, J.O. (1995). Laboratory manual for Soil and Plant Analysis. (Selected Method and Data Analysis). Published by the author. 140pp.
- Brady, N.C. and Weil, R. (2002). The Nature and Properties of Soils. 13<sup>th</sup> edition. Singapore, Pearson Education. 976pp.
- Badr, M. M. and Authma, A. S. (2006). Effect of plant density, organic manure, bio and mineral nitrogen fertilizers on maize growth, yield and soil fertility. *Annual Agricultural Science*, 44(1):75-88.
- Bashir, S (2012). Response of brown sarson to NPK application under early, normal and late sown conditions [Ph. D thesis], Division of Agronomy, SKUAST-K. 223p
- Bastos, E. A., Cardoso, M. J., Melo, F. B., Ribeiro, V. Q. And Andrade Junior, A.S. (2008). Rates and timing of nitrogen application for obtaining the economic grain yield, under no-tillage. *Revista Ciencia Agronomica*. Vol.26:593-606.
- Cruz, S. C. S., Pereira, F. R. S., Santos, J. R., Albuquerque, A. W. and Pereira, R.G. (2008). Nitrogen fertilization for corn cultivated under a no-tillage system in the state of Alagoas, Brazil. *Revista Brasileira de Engenharia Agrícola e Ambiental*. Vol:12:62-68
- Cancellier, L.L., Afféri, F.S., Carvalho, E.V., Dotto, M.A., Leão, F.F. (2011). Eficiência no uso de nitrogênio e correlação fenotípica em populações de milho no Tocantins. *Revista Ciência Agrônômica*, 42: 139-148.
- Deparis, G.A., Lana, M.C. and Frandoloso, J. F. (2007). Row spacing and nitrogen and potassium fertilization in covering for the corn culture. *Acta Scientiarum Agronomy*. Vol: 29:517:525.
- Ferreira, A.C.B., Araújo, G.A.A., Pereira, P.R.G., Cardoso, A.A. (2001). Corn crop characteristics under nitrogen, molybdenum and zinc fertilization. *Scientia Agricola*, 1: 131-138
- Festus K, Wilkson M, Gudeta S, Oluyede C, David M (2007). Synergistic effect of inorganic N and P fertilizers and organic inputs from *Gliricidia sepium* on productivity of intercropped maize in southern Malawi. *Plant Soil*. 294: 203 - 217
- Gul, S., Khan, M. H., Khanday, B.A., and Nabi, S. (2015). Effect of sowing methods and NPK Levels on Growth and Yield of Rainfed Maize (*Zea mays* L). *Scientifica*. Volume 2015, Article ID 198575, 6 pages.
- Hafiz M, Ashafaq A, Aftab W, and Javid A., (2011). Maize response to time and rate of nitrogen application. *Pakistan Journal of Botany* 43(4): 1935-1942.
- Jehan B, Shakeel A, Mohammed T, Habib A, Mohammed S (2006). Response of maize to planting methods and fertilizer. *Nigerian Journal of Agriculture and Biological Science* 1(3)8-14.
- Le Gouis J, Beghin D, Heumez E, and Pluchard, P. (2000). Genetic differences for nitrogen utilization efficiencies in winter wheat. *European Journal of Agronomy*, vol.12, no 3-4, pp163-173.
- Mahamed B, and Awale D (2013). Effect of different planting methods and nitrogen fertilizer rates on growth and yield of maize under rain-fed condition. *Journal of Agriculture* 1(1):71-79.
- Merkebu G, and Ketema B (2013). Yield related traits and yield of maize as affected by green manuring and nitrogen levels at Mizan Teferi, southwest Euthiopia. *International Journal of Agronomy and Plant Production*. 4 (7) :1462-1473.
- Mohammed M, and Hassan A. (2011). Effect of different nitrogen sources on growth, yield and quality of fodder maize (*Zea*

- mays L.). *J. Saudi Soc. Agric. Sci.* 10: 17-23.
- Okuruma, R. S., Takahashi, H. W., Santos, D. G.C., Lobato, A. K. S., Mariano, D.C., Marques, O.J., Silva, M. H.L.S., Neto, C. F.O., and Lima Junior, J.A. (2011). Influence of different nitrogen levels on growth and production parameters in maize plant. *Journal of Food, Agriculture and Environment* Vol.9(3&4): 510-514.
- Ronald J, John P, Larry D, Barney W (2005). Corn yield response to nitrogen rate and timing in sandy irrigated soils. *Am. Soc. Agron.* 97:1230-1238.
- Tisdale S, Havlin J, Nelson L, Beaton D, (1999). *Soil fertility and fertilizers* 6<sup>th</sup> ed. Macmillan Publishing . USA. Pp. 85-196.
- Sangoi, L., Almeida, M.L., Pucci, A.L.R., Strieder, M., Zanin, C.G., Silva, L. Vieira, L.J. (2008). Early nitrogen side – dress application does not increase wheat grain yield at the aluminum presence. *Ciência Rural*, 4: 912-920.
- WagaM (2011). Effects of methods and rates of phosphorus fertilizer application and planting methods on yield and related traits of maize on soils of Hawassa area. *Innov. Syst. Design and Eng.* 2(4):315-335.



# GROWTH PERFORMANCE OF POP CORN AS INFLUENCED BY NITROGEN FERTILIZER RATE AND INTRA-ROW SPACING AT BADEGGI, NIGERIA

M.K Ndagen<sup>1</sup> and Adamu Saidu<sup>2</sup>

<sup>1</sup>Department of Crop and Forestry, NAERLS/ABU, Zaria.

<sup>2</sup>Department of Crop Production, Federal University of Technology, Minna.

**Corresponding author:** kolomuhammad3@gmail.com

**Phone:** 08060971423

## Abstract

Two field trials were conducted in 2016 and 2017 rainy season in Research Farm of National Agricultural Extension and Research Liaison Services, Ahmadu Bello University, (NAERLS/ABU), North Central Zone, Badeggi, Niger State, Nigeria ( $9^{\circ}45'N$ ,  $7^{\circ}31'E$ ) to test the effect of Nitrogen Fertilizer rate and Intra-row spacing on Growth and Development of Popcorn (*Zea Mays Averta*) var Samm II. The treatment were made up of three Intra-row spacing (20, 25 and 30cm) and for nitrogen fertilizer rate (0kg N/ha, 60kg N/ha, 120kg N/ha and 180kg N/ha). Increase in nitrogen fertilizer rate significantly increased plant height at 8 and 12 weeks after sowing (WAS) in 2016 and 2017 rainy seasons respectively. The highest rate of 180kg N/ha produced taller plant than lower rate of 60kg N/ha. Total Dry Matter (TDM) was significantly affected by N fertilizer only at 12 WAS in 2016 and at all stage in 2017. Leaf Area Index LAI was significantly affected by nitrogen application through out the season except at 4 WAS in 2016 season. Intra-row spacing had no significant effect on plant height except at 8 WAS in 2017 rainy season. TDM was significantly affected by intra-row spacing only at 12 WAS in 2016 and at intra-row spacing only at 12 WAS in 2016 and at all stages in 2017 rainy season wehre spacing at 30cm produced highest TDM plant.

**Keyword:** Nitrogen, Intra-row spacing, Pop corn (Sam 11)

## Introduction

Pop corn is a popular snack, an important part of diet of many people in most region of the world. The rapid increase in the use of Pop corn as snacks at amusement parks, theafters or around family television has greatly increased the demand for Pop corn.

The demand has out-run the supply each year, hence, Pop corn production has turned out to be a very valuable income earning, FAO (2011). The need to increase or boost popcorn production through agronomic research cannot be over-emphasized.

One of the problems of Pop corn production is poor yield. The poor performance of Pop corn in Nigeria has been attributed to low-input crop production practices, severe crop environmental stresses, and the use of low yielding varieties. There are several crop production practices that could influence growth and performance of crops. These practices include land preparation, spacing, fertilization, time of planting and time of harvesting etc. Optimum plant spacing and nitrogen fertilizer appear to have significant roles in determining yield capacity of Pop corn.

Plant population is another important factor that determine the yield capacity of crops per unit area



of land. Plant population is determined by plant spacing. The current practice among the peasant farmers producing Pop corn in the study area is to plant at a spacing of 60cm by 60cm, this spacing might not guarantee optimum yield per unit area. In view of the response of Popcorn to nitrogen fertilization and plant population especially the improved varieties this experiment was conceived to determine the best intra-row spacing and optimum N rate for maximum growth and yield of Pop corn variety Sam 11.

### **Material and Methods**

Experiment were conducted in 2016 and 2017 rainy season at the Research Farm of National Agricultural Extension and Research Liaison Service, Ahmadu Bello University, Zaria (NAERLS/ABU), North Central Zone, Badeggi (9°45'N, 7°31'E) within the Southern Guinea Savannah ecological Zone of Nigeria. The treatment consisted of three intra-row spacing (20, 25 and 30cm) combined with four nitrogen levels (0, 60, 90 and 120 kg N/ha). Split plot design was used with three replications.

The variety Samaru II was obtained from the Institute of Agricultural Research, Ahmadu Bello University, Zaria (IAR/ABU) was used as a test crop. The land was prepared by harrowing and ridges 75cm apart were made. The gross and net plots were 19.93 and 17.5m respectively. Seeds were sown at intra-row spacing dictated by the treatment combination.

Planting was done on 7<sup>th</sup> June, 2016 and 11<sup>th</sup> June, 2017 rainy seasons. Three seeds were sown per hole at intra-row spacing 75cm apart and intra-row spacing of 20, 25 and 30cm respectively and thinned to one plant. Weed were controlled with pre-emergence herbicide gly-weed with CP<sub>3</sub> Knapsack sprayer immediately after planting

followed by manually weed control using hoe at 4 and 9 Weeks after sowing in the Experimental plots. Soil sample were collected from the field at 0-30cm depth and analysed for physic-chemical properties using standard procedures. Basal fertilizer application of compound NPK 15:15:15 grade was first half dose applied at 2 WAS respectively with appropriate additional nitrogen fertilizer treatment using Urea (46%N) as source to balance nitrogen level of (0, 60, 120 and 180 kg N/ha).

Data on plant height, Total Dry Matter and Leaf Area Index were collected from five randomly tagged plant plot at 4, 8 and 12 weeks after sowing (WAS). The data collected were subjected to analysis of variance as described by Snedecor and Cochran (1967). The treatment means were compared using Duncan Multiple Range Test (DMRT) (Gomez and Gomez, 1984).

### **Results**

#### **Effect of Nitrogen Fertilizer Rate and Intra-row Spacing of Pop Corn on Plant Height**

The result of the soil analysis varied as shown in Table 1. The soil chemical properties was generally low in organic carbon, total nitrogen. The Electrical Conductivity (EC) value of the soil (0.08 and 0.09ds/m<sup>2</sup>) indicated that the soil were not salt affected. From the result (Table 1), the soil texture class at the experimental site was sandy loam. The soil was slightly acid tending to alkaline (5.40 to 6.0) condition in water indicating moderate soil condition for pop corn production Kamprath (2009).

Table 2 show the influence of Nitrogen Fertilizer rate and intra-row spacing of pop corn on plant height at 4, 8 and 12 WAS during 2016 and 2017 rainy seasons. In 2016 season, Nitrogen rate only had significant effect at 12 WAS where application

of 180kg N/ha resulted in taller plant than application of 120kg N/ha of N rates. Intra-row spacing had no significant effect on plant height during the period of growth. None of the treatment interactions on plant height was found to be significant. While in 2017 rainy season Nitrogen fertilizer rate had no any significant effect on plant height through-out the stages of growth. Also intra-row spacing had no any significant influence on plant height during all stages of growth.

**Table 3**

**Effect of Nitrogen Fertilizer and Intra-row Spacing of Pop corn on Total Dry Matter (TDM).**

The effect of nitrogen fertilizer rate and intra-row spacing of pop-corn on Total Dry Matter per plant at 4, 8 and 12 WAS in 2016 and 2017 rainy seasons are shown in Table 3. In 2016 at 4 and 8 WAS the application of nitrogen fertilizer on Total Dry Matter (TDM) was not significant. However, at 12 WAS application 180kg N/ha significantly produced higher TDM plant than application of 120kg N/ha. At 4 and 8 WAS intra-row spacing on TDM was not significant. However, at 12 WAS, 30cm intra-row spacing produced highest dry matter only than at 25cm.

In 2017 rainy season, however, each increase in nitrogen fertilizer rate significantly increased TDM of Pop corn at both 4 and 8 WAS. At 12 WAS however, there were no significant difference on TDM between 120kg N/ha and 60kg N/ha. Application of 180kg N/ha produced higher TDM than 120kg N/ha.

When intra-row spacing was considered, it was found that at both 4 and 12 WAS each increase in intra-row spacing significantly increased TDM. However, at 8 WAS there was no significant difference in the TDM at 5 and 30cm intr-row

spacing both of which were statistically higher than 20cm intra-row spacing.

**Table 4**

**Effect of Nitrogen Fertilizer Rate and Intra-row Spacing of Pop Corn on Leaf Area Index (LAI).**

Leaf Area Index (LAI) as affected by application of Nitrogen fertilizer rate and intra-row spacing at 4, 8 and 12 WAS in 2016 and 2017 rainy seasons are presented in Table 4. In 2016 rainy season at 4 WAS, nitrogen fertilizer rate had no significant effect on leaf area index, However, at both 8 and 12 WAS application of 180kg N/ha resulted in significant increase in Leaf Area Index than 120kg N/ha and 60kg N/ha which were at par.

In 2017, nitrogen fertilizer significantly influenced leaf area index. Each increase in nitrogen fertilizer rate resulted in significant increase in leaf area index at all sampling stages except at 8 WAS when there was no significant difference between 180kg N/ha and 120kg N/ha. Intra-row spacing of 5 and 30cm resulted in similar leaf area index but significantly higher than 20cm intra-row spacing at both 4 and 12 WAS. Intra-row spacing had no significant effect on leaf area index at 8 WAS.

**Discussion**

The no significant values obtained for most of the growth parameters at early stage of the crop growth indicates low nutrient demands during the initial stage of crop growth and development, thus the soil might have satisfied all the crops need. However, the positive response to applied nitrogen fertilizer at later stages for some of the growth parameters could be due to the fact that at this stage available nutrients in the soil could no more meet the crop requirements without the use of fertilizer. This confirms the observation made by Abayomi; et al., (2013) who reported that Maize growth expressed in terms of plant height, stem girth, crop growth

rate, relative growth rate CGR, RGR, NAR showed a positive response to applied fertilizer up to the highest rate of 120kg N/ha. However, Jaliya *et al* (2013) reported that 150kg N/ha significantly produced taller plants, more number of leaves and heavier dry matter level.

The non-significant response of most of the growth attributes of pop corn to varying intra-row spacing could be attributed to the fact that the variety Sam II used has genetically small morphological structure and so there was moderate competition for light. This mean that adequate growth factors were equally provided to the crop at this spacing, thereby minimising interplant competition. This might have provided similar amount of assimilates that make up these important parameters under the ranges of plant population used. Similarly, the crop being a C<sub>4</sub> plant has maximum photosynthetic rates due to low CO<sub>2</sub> compensation point.

The significant interaction recorded between nitrogen fertilizer and intra-row spacing on LAI indicated the complementary role played between those factors on vegetative growth of Pop corn. Significant interaction between intra-row spacing and nitrogen was observed at 12 WAS in 2016 trial only. Application of 180kg N/ha and 30cm intra-row spacing gave significantly higher plant height than all other treatments combination except 120kg N/ha and 25cm intra-row spacing (Table 5). Significant interaction was also observed on Pop corn grain yield in 2016 trial and that the highest grain yield was obtained with application of either 120kg N/ha or 180kg N/ha and 30cm intra-row spacing (Table 6).The yield increase with higher nitrogen rate of wider spacing could be due to maximum dry matter production for grain filling that was made possible as a result of taller plants that trapped most of the photosynthetically active radiation, more number of leaves per plant that

provided more surfaces for photosynthesis and assimilates production.

This result agreed with that of Tatero and Ojima (2003). Considering the main effect and the interaction, wider spacing seem to favour the growth and yield of Pop corn. On the other and 120kg N/ha was found to be adequate for good growth and yield of popcorn at Badeggi. The interaction effect have shown that 30cm intra-row spacing and 120kg N/ha gave a higher growth, total dry matter and leaf area index that was comparable to 25cm and 180kg N/ha combination. For economic reason 30cm intra-row spacing and 120kg N/ha could be recommended for Pop corn production in Badeggi.

## REFERENCES

- Abayomi, Y.A; Olagoke, O.A and Tunji, R.A; (2013).Interaction Effects of Water Stress and Nitrogen Application on Growth and Yield of Hybrid Maize Varieties. *The plant Scientists* (5) 71-87
- FAO (2011).Food and Agricultural Organization FAOSTAT on Crop Production. [www.fao.org/FAOSTAT](http://www.fao.org/FAOSTAT)
- Gomez, K.A. and Gomez, A.A (1984).Statistical Procedures for Agricultural Research.Second Edition.A Wiley Interscience Publication Wiley and Sons. Pp: 207-215.
- Jaliya, M.M; A.M. Falaki, M. Mahmud and Y.S. Sani (2013). Growth and Yield of Quality Protein Maize (*Zea Mays L*) as affected by date of Sowing, Intra-row Spacing and Nitrogen Fertilizer Rate. *J. Crop Res. Agro & Environ* 2:57-61.
- Kamprath, L.A. (2009). *Methods of Soil Analysis*.Part 3.Chemical and Microbiological Properies 5<sup>th</sup> Edition, Agronomy Series 10, SSSA, Madison, Wis. USA.
- Snedecor, G.W. and Cochran W.G. (1967).Statistical Methods 6<sup>th</sup> Edition.Lowa State University Press, USA Ames.Lowa 456pp.
- Tatero, K.A; and Ojima M. (2003).Grwth Analysis Yield of Pop corn as Affected by



Intra-row Spacing, Planting Density and Amount of Nitrogen. Proceeding of the Crop Science Society of Japan, 42(4):555-559



**Table 1:** Physico-chemical properties of Soils from 0-30cm at Experimental Site During 2016 and 2017 Rainy Season.

Badeggi

Soil Properties	2016	2017
<b>Properties Size (g/kg)</b>		
Clay	130	110
Silt	150	140
Sand	720	750
<b>Chemical Properties</b>		
	<b>Sandy-Loam</b>	<b>Sandy Loam</b>
P <sup>H</sup> (H <sub>2</sub> O; 1:2:5 w/v)	5.40	6.10
P <sup>H</sup> (0.01M CaCl <sub>2</sub> ; 2.5 w/v)	6.20	6.60
Exchange Acidity (Cmol/kg soil)	0.05	0.06
Electrical Conductivity (mg/kg)	0.08	0.09
Bray/P (mg/k)	6.40	7.55
Organic Carbon (g/kg)	4.10	5.70
Total N (g/kg)	0.18	0.31
<b>Exchangeable Cations (Cmol/kg)</b>		
K (Cmol/kg)	0.17	0.25
Ca (Cmol/kg)	4.15	5.25
Mg (Cmol/kg)	0.45	0.91
Na (Cmol/kg)	0.23	0.29
CEC K (Cmol/kg)	5.65	6.75
<b>Extract Micro Nutrients (Cmol/kg)</b>		
Zinc (Zn)	6.15	6.55
Sodium Adsorption Ratio (SAR)	0.05	0.07
Percent Base Saturation (PBS)	84.20	88.60

Source: Soil samples as analysed at the Soil Department, Federal University of Technology (FUT), Minna, Niger State, Nigeria.

**Table 2:** Effect of Nitrogen Fertilizer Rate and Intra-row Spacing on Plant Height (cm) of Pop corn during 2016 and 2017 rainy season.

Treatment	Week After Sowing					
	2016			2017		
N Rate F	4	8	12	4	8	12
0	25.0	43.5	62.4	22.6	41.6	61.4

60	43.8	57.6	128.6	41.4	53.9	125.3
120	51.7	96.4	131.7	52.8	97.3	135.7
180	55.3	111.3	137.5	57.5	110.5	139.5
SE±	1.9	3.02	2.6	1.74	3.6	3.4
<b>Intra-row Spacing P</b>						
20cm	40.2	74.2	105.7	38.5	71.3	103.9
25cm	44.6	77.5	109.3	42.4	74.6	107.3
30cm	47.3	82.6	127.9	45.3	79.5	125.3
SE±	2.03	3.5	2.4	1.36	22.61	5.7
<b>Interaction F</b>	<b>Ns</b>	<b>Ns</b>	<b>Ns</b>	<b>Ns</b>	<b>Ns</b>	<b>Ns</b>
<b>X P</b>						

Mean followed by the same letters within a column and treatment group are statistically similar  $P < 0.05$  using DMRT. ns = Not Significant.

**Table 3:** Effect of Nitrogen Rate and Intra-row Spacing on Total Dry Matter (TDM) (g) of Pop corn during 2016 and 2017 Rainy Season.

Treatment	Week After Sowing					
	2016			2017		
N Rate F	4	8	12	4	8	12
0	9.7	39.7	91.5	11.2	41.4	97.3
60	16.2	51.3	203.4	18.4	61.5	207.3
120	22.4	101.3	310.3	25.4	112.4	313.5
180	24.6	113.7	332.6	27.3	119.3	339.3
SE±	0.12	1.05	5.06	27.2	3.6	6.01
<b>Intra-row Spacing (P)</b>						
20cm	16.6	87.6	228.4	17.3	89.3	228.4
25cm	18.2	93.5	236.7	18.1	95.7	236.7
30cm	19.3	99.4	248.4	19.7	101.3	239.4
SE±	0.11	0.91	5.10	0.13	0.50	5.20
<b>Interaction F</b>	<b>Ns</b>	<b>Ns</b>	<b>Ns</b>	<b>Ns</b>	<b>Ns</b>	<b>Ns</b>
<b>X P</b>						

Mean followed by the same letter(s) within a column and treatment group are statistically similar  $P < 0.05$  using DMRT. ns = Not Significant.

**Table 4:** Effect of Nitrogen Fertilizer Rate and Intra-row spacing on Leaf Area Index (LAI) of Pop corn during 2016 and 2017 Rainy Season.

Treatment	Week After Sowing					
	2016			2017		
N Rate F	4	8	12	4	8	12
0	0.43	0.91	1.57	0.31	0.55	1.42



60	0.51	2.31	3.19	0.45	2.25	2.91
120	0.54	2.95	4.20	0.50	2.83	3.75
180	0.57	3.25	5.10	0.54	2.10	4.84
SE±	0.003	0.039	0.027	0.002	0.012	0.024
<b>Intra-row Spacing (P)</b>						
20cm	0.6	3.3	4.9	0.5	2.4	3.9
25cm	0.5	3.8	4.7	0.6	2.3	3.6
30cm	0.5	3.3	4.9	0.6	2.3	4.3
SE±	0.04	0.010	0.014	0.002	0.008	0.011
<b>Interaction F</b>	<b>Ns</b>	<b>Ns</b>	<b>Ns</b>	<b>Ns</b>	<b>Ns</b>	<b>Ns</b>
<b>X P</b>						

Mean followed by the same letter(s) within a column and treatment group are statistically similar  $P < 0.05$  using DMRT. ns = Not Significant.

**Table 5:** Interaction between Nitrogen Fertilizer Rate and Intra-row Spacing of Pop corn on Leaf Area Index (LAI) at 8 WAS in 2016 rainy season at Badeggi.

Treatments Nitrogen (kg N/ha)	Intra-Row Spacing (cm)		
	20	25	30
0	2.20	2.30	2.35
60	3.15	3.30	3.40
120	4.06	4.16	4.30
180	4.28	4.36	4.53
SE±	0.0003		

Means followed by the same letter(s) are not significantly different at 1% level of probability  $P < 0.05$  using DMRT.

**Table 6:** Interaction between Nitrogen Fertilizer Rate and Intra-row spacing of Pop corn on plant height at 12 WAS in 2016 rainy season at Badeggi.

Treatments Nitrogen (kg N/ha)	Intra-Row Spacing (cm)		
	20	25	30
0	68.4	71.3	75.3
60	102.6	109.5	113.4
120	124.3	128.3	131.4
180	128.8	130.3	135.7
SE±	0.008		

Means followed by the same letter(s) are not significantly at 5% level of probability  $P < 0.05$  using DMRT.

## PRICE BEHAVIOUR OF LOCAL AND IMPORTED RICE IN RURAL AND URBAN MARKETS OF NIGER STATE, NIGERIA

Bako<sup>1\*</sup>, R.U., F.D. Ibrahim<sup>1</sup>, C.O. Adebayo<sup>1</sup> and U.S. Mohammed<sup>1</sup>

<sup>1</sup>Department of Agricultural Economics and Farm Management, Federal University of Technology Minna, Niger State, Nigeria

\*Corresponding Author e-mail: [r.usman@futminna.edu.ng](mailto:r.usman@futminna.edu.ng) GSM: 07060733035

### ABSTRACT

*The study analysed the price behavior of local and imported rice in rural and urban markets of Niger state, Nigeria, the specific objectives were to examine the trend in prices, determine the co-integration between the price series and to ascertain the market that causes the movement and direction of prices. Secondary data which was the average monthly retailed prices of local and imported rice in rural and urban markets per kilogram of rice was used from January 2000 to December 2016 (204 observations). The data was sourced from Niger State Bureau of Statistics and was analysed using descriptive statistics, Augmented Dickey Fuller (ADF) test, Johansen cointegration, Error Correction Model (ECM) and Granger Causality test. The result shows that the mean prices of local rice in rural and urban markets were ₦41.13 and ₦116.22 per kilogram, while that of imported rice was ₦201.85 and ₦207.55 and the kurtosis shows that the variables are normally distributed. The graph of the trend shows an upward and irregular pattern in the prices of both local and imported rice in the two markets. The ADF test shows that the variables become stationary at first difference I(1), and the result of the Johansen indicated the presence of cointegration among the variables as shown by the trace statistics and max Eigen statistics which were significant at 5% level of probability each. The ECM result shows that there is a long run relationship among the prices but there was a low speed of adjustment in the short run as indicated by the coefficient of -0.0139. The granger causality result shows a unidirectional causal relationship between prices of imported rice in rural and urban markets and also in prices of local rice in urban and rural markets over the period of study. It is recommended that the flow of market information should be enhanced by the marketers and also government should be firm on its policy on rice.*

**KEY WORDS: price trend, local and imported rice, urban and rural markets**

### INTRODUCTION

Global demand for agricultural products is expanding rapidly and the demand for food products is foreseen to continue to grow for several decades as a result of a combination of population growth, rising per capita incomes and urbanization (Nasirinet *al.*, 2015). In developing countries, approximately 60 % of total calories consumed are derived directly from cereals, among which rice is the most important source of calories for humans. Rice is the most important staple food for about half of the human race (Imolehin and Wada, 2000).

The demand for rice in Nigeria has been soaring over the years (Ayanwale *et al.*, 2011), since mid 1970s, rice consumption in Nigeria has risen tremendously growing by 10.3% per annum. According to Federal Ministry of Agriculture and Rural Development (FMARD), (2011), there is an increasing demand for rice in Nigeria, as rice consumption was 5 million metric tons in 2010 and is expected to reach 36 million metric tons by 2050. According to NBS (2012), a study on household expenditure by commodity, shows that urban households spend 8.65% of their income on rice and the rural

household spend 9.07% of their income on rice. A combination of various factors seems to have triggered the structural increase in rice consumption over the years with consumption broadening across all socio-economic classes, including the poor (Oyinboet *al.*, 2013). According to (Global Agriculture Information Network GAIN, 2012), the rising demand is as a result of increasing population growth and income level. In 2016 the estimated demand for rice is 6.3 million tons, while the supply is 2.3 million tons (FMARD, 2016). And according to Daramola (2005) and Awe (2006) any shortfall in supply of rice creates incentive for rice importation in the country, which cause the country a huge sum of money.

Prices are signals that direct and coordinate not only the production and consumption decisions but also the marketing decisions over time, form and space (Kohls and Uhl, 2001), Price is a major endogenous determinant of supply and demand for rice. The price of the commodity is center to its transaction, and the quantity bought by buyers usually depend on their purchasing power in relation to the price. According to Mondal (2010), agricultural produce prices are notoriously unstable and consequently, price instability leads to uncertainty in the income of the

producers as well as the quantity purchased by the consumer.

Niger state is a rice producing state with an average production rate of 5 tons per hectare and this rank the state as the highest producer of rice in Nigeria (Jalingo,2017), also Niger State Ministry of Agriculture (2017), estimated rice production figure shows a yield of 5.31 tons per hectare. But despite this the price of rice have been increasing in the state as show by NBS price statistic and also different varieties of imported rice are seen all over the area. According to Paulin (2011), the continuous and persistent increase in price of food commodities can lead to food insecurity and significantly affects the poor people in both urban and rural areas, as their purchasing power erodes as prices increase. According to Burakov, (2016) a rise in food prices put pressure on the house hold sector of an economy . Therefore, fluctuations in the prices of agricultural products (especially major staples) have become of great concern to economists and policy makers (Adekoya *et al.*, 2013). Thus, there is need to know the trend in the prices, the direction of the movement in prices between rural and urban markets among other things to be able to inform and guide policy makers adequately.

#### Objectives of the study

The aim of the study is to examine price behavior of local and imported rice in rural and urban markets of Niger state. The specific objectives are;

1. examine the trend in prices of local and imported rice in rural and urban markets in the study area,
2. to determine cointegration between prices of local and imported rice in rural and urban markets in the study area, and
3. to ascertain the market that causes the movement and direction of prices of local and imported rice in rural and urban markets in the study area.

#### METHODOLOGY

##### Study Area

The study area is Niger State (North Central) Nigeria. Niger State was carved out of the former North-Western State in 1976 and it is located in North Central Nigeria. The State lies between Latitudes 8°20' and 11° 30' North and Longitudes 3°30' and 7° 20' East and share border with the Republic of Benin (West), Zamfara State (North), Kebbi (North-West), Kogi (South), Kwara (South-West), Kaduna (North-East) and South-East by FCT Abuja (National Bureau of Statistics (NBS), 2009). The 2006 population census shows that the state has a population of 3,950,249 with an annual growth rate of 3.4% (National Planning Commission (NPC), 2006). The projected population at 3.4% annual growth rate

gives a population of 5,293,333 by 2016, Niger State is among the largest States in Nigeria covering about 86,000km<sup>2</sup> (or about 8.6 million hectares) representing about 9.3% of the total land area of the country (Development Action Plan for Niger State, 2008) and about 95% of the land is arable and serve as source of employment for the predominantly rural population whose primary occupation is farming.

Niger State experiences two distinct climatic seasons in a year, these are rainy and dry seasons. Rainfall is steady and evenly distributed, usually between May and November, varying from 1,100mm to 1,600mm in the southern part of the state. Its maximum temperature is normally 37°C which is recorded between March and June, while minimum temperature is around 21°C recorded between December and January (Development Action Plan for Niger State, 2008).

#### Method of Data Collection and sample size

This study mainly used secondary data which is average monthly retailed prices of local rice for rural and urban markets in Niger State. The data were collected from Niger State Bureau of Statistics and Niger State Ministry of Agriculture, for a period of 17 years that is from January, 2000 to December, 2016, thus the number of observation is 204.

#### Method of Data Analysis

The study will apply series of statistical and econometric tools to achieve the stated objectives. The tools to be used include descriptive statistics, Augmented Dickey Fuller (ADF) test for stationarity, Vector Autoregressive Model (VAR), Co-integration and Granger Causality test

The presence of unit root in a time series means the series is nonstationary and this generates unreliable results regarding the hypothesis testing According to Upender (2012), one method of testing for unit root and the order of integration of time series is the use of ADF.

Given the autoregressive process of order one AR

$$Y_t = \phi Y_{t-1} + e_t \quad (1)$$

When constant and trend is added to equation 1, it becomes

$$\Delta Y_t = \alpha_1 + \alpha_2 t + \beta Y_{t-1} + \phi_i \sum_{i=1}^m \Delta Y_{t-i} + e_t \quad (2)$$

Where;  $Y_t$  = price in time  $t$ ,

$\Delta$  = first difference operator

$\alpha$ ,  $\beta$  and  $\phi_i$  = parameters to be estimated

$e_t$  = a serially uncorrelated white noise error term .

if  $\phi = 1$ , the serie  $Y_t$  is nonstationary, if  $\phi < 1$  then the series  $Y_t$  is stationary.



Also, a suitable lag was selected for each of the analysis using the various lag length selection criteria such as Akaike's information criterion, Schwarz information criterion, Hannan-Quinn criterion, Final prediction error and Corrected version of AIC:

Descriptive statistic was used to achieve objective 1, where summary statistics of the prices including mean, minimum, maximum, skewness, kurtosis as well as graphs were used to examine the trend in the price series.

Johansen co-integration test was used to achieve objective 2, the variables were modelled as Vector Autoregressive Model (VAR). The general model is specified as;

$$\Delta p_t = \alpha + \sum_{i=1}^{k-1} \Gamma_i \Delta p_{t-1} + \Pi p_{t-1} + \mu_t \quad (3)$$

Where;

$\Delta$  = is the first difference operator,

$p_t$  = is a  $n \times 1$  vector containing the price,

$\Gamma_i$  = The matrix of short run coefficients,

$\Pi$  = The matrix of long-run coefficients,

$\mu_t$  = The normally distributed errors and

$K$  = Number of lags that will be adequately large enough to capture the Short-run dynamics of the underlying VAR and to produce normally distributed white noise residuals.

An appropriate lag length was selected by minimizing one of the following information criteria. Akaike Information Criterion (AIC), Schwarz Bayesian Criterion (BIC) and Hannan-Quinn Criterion (HQC).

Granger causality test was use for objective 3, the Granger model for this study as adopted from Izekoret *et al.*, 2016 is represented as;

$$RP_t = \alpha_0 + \sum_{i=1}^m \alpha_i UP_{t-1} + \sum_{j=1}^n \beta_j RP_{t-j} + \varepsilon_t \quad (4)$$

Where;

$n$  = number of observations,

$M$  = number of lag ,

$RP_t$  = rural market price,

$UP_t$  = urban market price,

$\alpha$  and  $\beta$  = parameters to be estimated and

$\varepsilon_t$  = error term

Hypothesis

$H_0$ : price of rice in one market does not determine the price of rice in the other market

$H_1$ : price of rice in one market determine the price of rice in the other market

## RESULTS AND DISCUSSIONS

The summary statistics of the prices showed that the minimum and maximum prices for local rice was ₦28.97 and ₦325.98, ₦20.01 ad ₦276.68 in urban and rural markets respectively and ₦150.04 and ₦345.87, ₦135.59 and ₦346.02 in urban and rural markets for imported rice per kg in Niger state. Furthermore, all the prices were positively skewed to the right. Price of imported rice for both rural and urban markets in Niger State were significant at 1% probability level ( $P < 0.01$ ) while price of local rice in both rural and urban markets of the study area were significant at 5% probability level ( $P < 0.05$ ) indicating that these variables had the kurtosis matching that of a normal distribution.

The trend in the rice price series were visualized by the use of graphical plots, the trend in urban and rural market prices of local rice in Niger state as shown in figure 1. has been increasing and the urban market price was always higher than the rural (producing) market, but at the tail end in 2016 prices were almost very close with a little difference between the rural and urban markets especially in the months of 196-200 that is April-August 2016.

Figure 2 shows the trend in imported rice prices in both rural and urban markets, the price series for both markets shows almost the same pattern throughout the period under study. This may be attributed to the fact that the rice was imported into the state.

The ADF test for stationarity as presented in table 1, shows that although all the variables were non stationary at levels but became stationary at first difference with order of integration 1,  $I(1)$ . This result is in accordance with the result of Emokaro and Ayantoyinbo (2014) who observed the same thing with monthly price series of local rice in their study. Also, all the variables were all significant at 1% probability level ( $P < 0.01$ ).

Since all the variables were integrated of the same order  $I(1)$ , Johansen test for cointegration was used to determine long run relationship for the variables. The result as presented in table 2 shows a trace statistic of 351.6595 which is greater than the critical value 47.21 at 5% level of significance ( $P < 0.05$ ); thereby indicating that there was one co-integration equation among the variables. Therefore, based on the decision rule, the null hypothesis of no co-integration among the variables price of imported rice in rural and urban areas and price of local rice in rural and urban areas of Niger State was rejected. This implies that there is a long run relationship among the variables. The result was also confirmed by the Max Eigen statistics of 133.2789 which is

greater than the critical value of 47.21 at 5% level of significance ( $P < 0.05$ ) thereby indicating the presence of co-integration among the variables. This result is in consistence with those of Ojoet *et al.*, (2015) and Akpan (2014), which all revealed the presence of co-integration between price series.

Since the variables were co-integrated, an Error Correction Model (ECM) was carried out to ascertain the speed of adjustment of the price series. Table 3 shows that in the long run, the result of ECM shows that the ECM coefficient (-1.1089) was negative and statistically significant at 1% probability level ( $P < 0.01$ ) which is an indication that there is a long run relationship between the prices during the period under study. The result also shows that the coefficient of price of imported rice in the rural areas and price of local rice in urban areas of Niger State were positive and statistically significant at 1% ( $P < 0.01$ ) probability level.

In the short run, the ECM coefficient as presented in table 3 was -0.0139, which indicates a low speed of adjustment of the variables towards equilibrium. This implies that the speed of adjustment at which the variables used in the model will be in equilibrium is at the rate of 1.39%. The values of the information criteria 30.8229, 31.1097 and 31.5319 for Akaike information, Hannan Quin and Schwarz respectively shows that the error in the model had been corrected.

The result of the granger causality test among the prices as presented in table 4 shows that there is a unidirectional causal relationship between price of imported rice in the rural markets of Niger State and price of imported rice in the urban markets of Niger State. That is, the price of imported rice in the rural markets of Niger State granger causes the price of

imported rice in urban markets of Niger State. This implies that the price of imported rice in the rural markets of Niger State can be used to predict the price of imported rice in the urban markets of the State. Hence, the null hypothesis of no granger causality was rejected at 1% probability level ( $P < 0.01$ ).

The result also shows a unidirectional causal relationship between price of local rice in the urban markets of Niger State and price of local rice in the rural markets of Niger State. That is, the price of local rice in the urban areas of Niger State granger causes the price of local rice in the rural areas of Niger State. This implies that the price of local rice in the urban areas of Niger State can be used to predict the price of local rice in the rural areas of the State. Hence, the null hypothesis of no granger causality was rejected at 10% probability level ( $P < 0.10$ ).

### CONCLUSION AND RECOMMENDATION

The result of the study has shown that prices of local and imported rice was increasing over the period under study, and were integrated of order one I(1). The prices are connected in the long run but have a low speed of adjustment in the short run. Though the null hypothesis of the granger causality of most of the market pairs were accepted, the alternative hypothesis was accepted for pairs of rural imported and urban imported as well as price of urban local and rural local which are all unidirectional.

It is recommended that the flow of market information should be enhanced by marketers, government policy on ban on the importation of rice should be firm and also local production should be enhanced and fully supported by government to close demand supply gap.

**Table 1: Augmented Dickey Fuller (ADF) Unit Root Test of the Price series**

Variable	Level	1 <sup>st</sup> Difference	Order of Integration	Critical Value (1%)	Critical Value (5%)
PNUI	-0.035 (0.9555)	-13.819*** (0.0000)	I(1)	-3.476	-2.888
PNRI	-1.140 (0.6987)	-15.169*** (0.0000)	I(1)	-3.476	-2.888
PNUL	1.440 (0.9973)	-12.078*** (0.0000)	I(1)	-3.476	-2.888
PNRL	-0.560 (0.8797)	-13.827*** (0.0000)	I(1)	-3.476	-2.888

**Source:** Output from data analysis, 2018.

\*\*\*implies significant at 1% probability levels respectively.

Figures in parenthesis are probability values.

**PNUI** = Price of Niger Urban Imported; **PNRI** = Price of Niger Rural Imported; **PNUL** = Price of Niger Urban Local; **PNRL** = Price of Niger Rural Local

**Table 2: Johansen Co-integration Test of the monthly price series**

Hypothesized No. of CE(s)	Max Statistics	Trace Statistics	Critical Value (5%)
None*	133.2789	351.6595	47.21
At most 1	90.6943	218.3806	29.68
At most 2	87.1296	127.6863	15.41
At most 3	40.5568	40.5568	3.76

**Source:** Output from data analysis, 2018.

\* implies rejection of null hypothesis at 5% probability level.

**Table 3: Estimates of the Vector Error Correction Model for the price series**

Variable	Coefficient	Standard Error	t-statistics
<b>Long Run</b>			
ECM (-1)	-1.1089	0.1923	5.77***
PNRI (-1)	-0.5095	0.0549	9.28***
PNUL (-1)	-0.2922	0.0753	3.88***
PNRL (-1)	-0.0425	0.0451	0.94
Constant	0.0834		
<b>Short Run</b>			
ECM (-1)	-0.0139	0.0293	1.12
PNUI (-1)	0.1151	0.1521	0.76
PNUI (-2)	0.0635	0.0958	0.63
PNRI (-1)	-0.3672	0.0816	4.50***
PNRI (-2)	-0.1632	0.0550	2.97***
PNUL (-1)	-0.1707	0.0977	1.75*
PNUL (-2)	0.0081	0.0908	0.09
PNRL (-1)	0.0129	0.0401	0.32
PNRL (-2)	0.0434	0.0398	1.09
Constant	-0.0137	0.7043	0.02
Log likelihood	-3039.277		
AIC	30.8228		
HBIC	31.1097		
SC	31.5319		

**Source:** Output from data analysis, 2018.

\*\*\*, \*\* and \* implies significant at 1%, 5% and 10% probability level respectively.

**PNUI** = Price of Niger Urban Imported; **PNRI** = Price of Niger Rural Imported; **PNUL** = Price of Niger Urban Local; **PNRL** = Price of Niger Rural Local; **AIC** = Akaike information criterion; **HBIC** = Hannan Quinn Criterion; **SC** = Schwarz criterion.

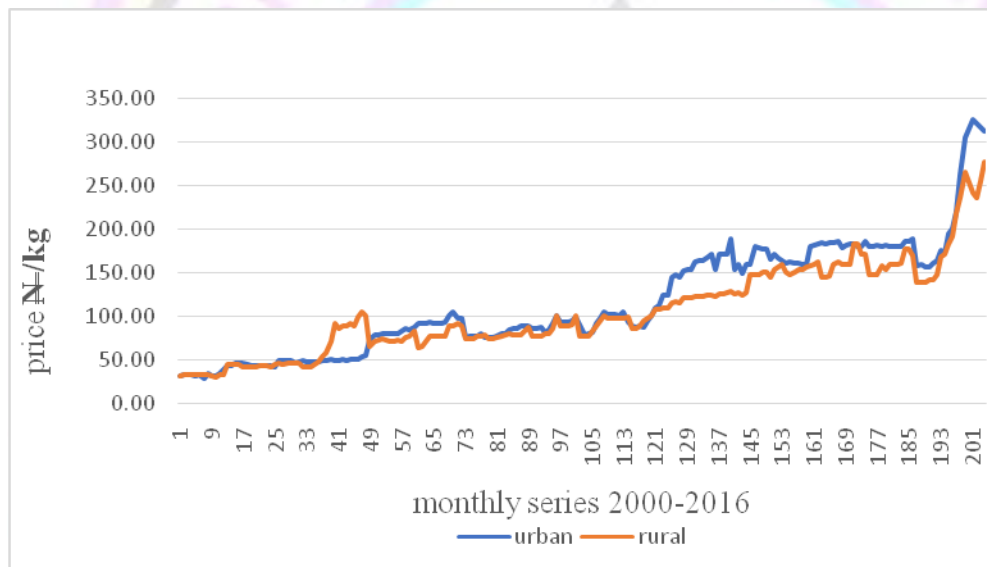


**Table 4: Result of granger causality test**

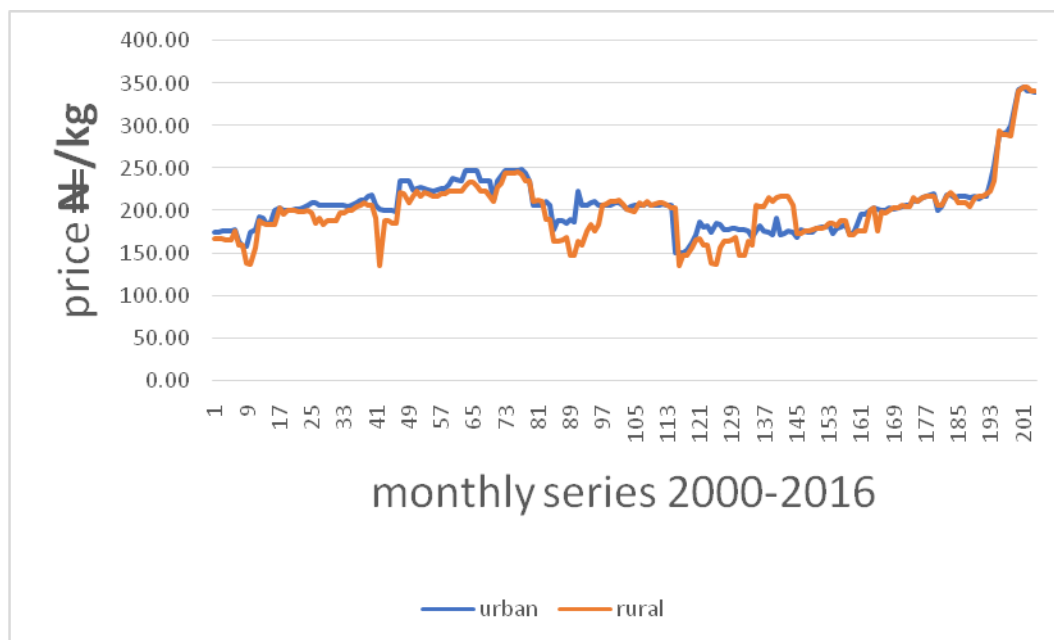
Null Hypothesis	F-ratio	Prob> F	Decision
PNUI does not granger cause PNRI	0.18727	0.8294	Accept
PNUI does not granger cause PNUL	2.3111	0.1020	Accept
PNUI does not granger cause PNRL	0.70307	0.4964	Accept
PNRI does not granger cause PNUI	10.069	0.0001	Reject
PNRI does not granger cause PNUL	2.0137	0.1364	Accept
PNRI does not granger cause PNRL	0.0045	0.9955	Accept
PNUL does not granger cause PNUI	0.29773	0.7429	Accept
PNUL does not granger cause PNRI	2.013	0.1365	Accept
PNUL does not granger cause PNRL	2.4168	0.0920	Reject
PNRL does not granger cause PNUI	0.6477	0.5260	Accept
PNRL does not granger cause PNRI	0.0377	0.9630	Accept
PNRL does not granger cause PNUL	1.586	0.2075	Accept

**Source:** Output from data analysis, 2018.

**PNUI** = Price of Niger Urban Imported; **PNRI** = Price of Niger Rural Imported; **PNUL** = Price of Niger Urban Local; **PNRL** = Price of Niger Rural Local.



**Figure 1: Trend in urban and rural market prices of local rice in Niger state**



**Figure 2: Trend in urban and rural market prices of imported rice in Niger state**

#### REFERENCES

- Adekoya, O.A., Ashaolu O.F., Adewuyi, S.A., Phillip, B., Dipeolu, A.O., & Omotayo, A.M. (2013). Price Trend Analysis of Selected Food Grains in Ogun State, Nigeria (1988-2012). *Journal of Agricultural Science and Environment* 13: 104-115
- Akpan, S.B., Ini-mfon V.P. & Udoka, S.J. (2014). Analysis of Monthly Price Transmission of Local and Imported Rice in Rural and Urban Markets in AkwaIbom State, Nigeria (2005-2013). *International Journal of Agriculture and Forestry* 4(1): 6-18.
- Awe, O. (2006). Ban on Rice Importation Depresses Global Trade. *Punch Newspaper*, May 20. [Online] Available: <http://www.punchng.com/> Accessed: Jan 20, 2015.
- Burakov, D. (2016). Oil Prices, Exchange Rate and Prices for Agricultural Commodities: Empirical Evidence from Russia", *AGRIS on-line Papers in Economics and Informatics*. 8 (2): 33-47.
- DAP (2008). Development Action Plan for Niger State, 2008.
- Emokaro C. O. & Ayantoyinbo A. A. Analysis of Market Integration and Price Variation in Rice Marketing in Osun State, Nigeria. *American Journal of Experimental Agriculture*, 4(5): 601-616
- Daramola, A.G. (2005). Government Policies and Competitiveness of Nigerian Economy. A Paper Presented at the Workshop on Rice Policy and Food Security in Sub-Sahara Africa. Organized by WARDA, Cotonou, Republic of Benin.
- Federal Ministry of Agriculture and Rural Development (2011). Agricultural Transformation Agenda Blue Print; we will grow Nigeria's Agricultural Sector.
- Federal Ministry of Agriculture and Rural Development (2016). The Green Alternative; Agricultural Promotion Policy 2016-2020. Policy and Strategy Document.
- Global Agricultural Information Network (2012). Global Agricultural Information Network, Nigeria Grain and Feed Annual Report. Report Number: NI1204.
- Imolehin E.D. & Wada A.C. (2000). Meeting the Rice Production and Consumption Demands of Nigeria with Improved Technologies, National Cereals Research Institute (NCRI) Badeggi, Nigeria.
- Izekor, O. B., Alufohai, G. O. & Eronmwon (2016). Analysis of Market Integration

- and Price Variation in Garri Marketing in Edo State, Nigeria. *Nigerian Journal of Agriculture, Food and Environment*. 12(4):123-130.
- Jalingo, M. (2017). Fadama III Intervention Increases Rice Production. By Niger Printing and Publishing Company, Published 27/03/2017.
- Kohls, R.L. &Uhl, J.N. (2001). *Marketing of Agricultural Products*, 9<sup>th</sup> edition, Englewood Cliffs. Prentice Hall.
- Mohanty, S. (2013). Trends in Global Rice Consumption. *Rice Today* 12(1):44–45. [Google Scholar](#)
- National Bureau of Statistics (2016). Nigerian GDP report; Quarter two 2016.
- Nasirin, S., Magnus J., Björn, H., Agnes A.D. &Göran, D. (2015). Drivers of Rice Production: evidence from five Sub-Saharan African countries. *Agriculture and Food Security* 4:12
- Ojo, A.O., Ojo, M.A., Adebayo, C.A & Coker, A. A. A. ( 2015). Analysis of Rural and Urban Rice Markets Integration in Niger State, Nigeria: Error Correction Model Approach. *Journal of Tropical Agricultural Research and Extension* 18 (1):41-51
- Oyinbo, P.O., Omolehin R.A. & Abdulsalam Z.(2013). Household Consumption Preference for Imported and Domestic Rice in Kaduna State, Nigeria: Implication for Rice Quality Improvement. *Production, Agriculture and Technology journal*Nassara State University Keffi. 9(1):29-37
- Paulin, N. (2011). A Value Chain and Market Integration Analysis of the Cassava Market in the Democratic Republic of Congo. Unpublished Thesis Department of Agricultural Economics and Rural Development, University of Pretoria. pp 4.
- Upender, M. (2012). *Applied Econometrics* 3<sup>rd</sup> Edition, Vrinda Publication Limited, 205.



# TOWARDS AN INTELLIGENT FARMLAND INTRUSION DETECTION AND VANDALIZATION PREVENTION SYSTEM USING DEEP LEARNING AND RASPBERRY PI

Abdullahi, I.M<sup>1</sup>, Olaniyi, O. M<sup>2</sup>., Maliki D<sup>3</sup>, Ayansina, E. A<sup>4</sup>, Ijah, J. U<sup>5</sup>

<sup>1-5</sup>*Department of Computer Engineering, Federal University of Technology, Minna, Nigeria*

1. [mikail.olaniyi@futminna.edu.ng](mailto:mikail.olaniyi@futminna.edu.ng) | [danlami.maliki@futminna.edu.ng](mailto:danlami.maliki@futminna.edu.ng)

## ABSTRACT

Farming is one of the most lucrative business in the world and one of the largest employers of labour worldwide. In addition, farming has been able to guarantee food security and increase the GDP of many countries. However, this sector in recent times have been threatened by conflicts between farmers and herders especially in developing countries such as Nigeria where loss of lives and properties have been recorded in many states. This emerging problem has brought to the fore the need for efficient intelligent farmland intruder detection and vandalization prevention system. Existing intruder detection and vandalization prevention systems do not have the capability to detect, recognize, prevent and alert the farmer in real time of an intrusion. Hence, this paper proposes the development of an intelligent intruder detection, recognition and vandalization prevention system using a Faster Regions with Convolution Neural Network (faster R-CNN) for efficient intruder recognition, IR sensors for intruder detection and Raspberry pi as hardware for efficient deployment. The successful development and deployment of this system will not only prevent vandalization of crops, minimize clashes between farmers and herders, but also, save lives and properties and guarantee food security.

**Keyword:** *Farmland, Intelligent System, Artificial Neural Network, Deep Learning, Raspberry pi, Food Security*

## INTRODUCTION

Agriculture is one of the most important sectors in worlds' economy and a major employer of labour in most countries of the world. Agriculture contributes more than 50% of national income in developing countries (Koutoudis, 2018). In Nigeria's economy for example, Gross Domestic Product (GDP) from agriculture increases from 3487312.92 million Naira to 3789720.12 million Naira in the second quarter of 2018 (Trading Economics, 2018). Hence, there is the need to protect these farmlands and crops from being vandalized. In developing countries like Nigeria, the second major threat to crop production after drought is vandalization by animals, majorly cattle, goats and sheep. This has led to one of the major challenges in sub-Saharan Africa, the farmers-herdsmen crises. This problem is so pronounced

that not just crops are being vandalized but also human lives and properties are lost as witnessed in some major cities in Nigeria of recent. Some factors such as weather conditions, density, distribution of problem species, availability of off-farm and on-farm habitat and type of production to mention a few are responsible for the migration of animals into farmlands to destroy crops.

Surveillance plays important role in security in many areas such as at home, schools, farmlands, banks, and public places. It helps us to monitor a given area against theft and provide evidence when they eventually occur (Chinmaya *et al.*, 2017). In the case of farmlands, surveillance is important in detecting unauthorized humans and animals and possibly inform or alert the farm owner of intrusion. Gophika *et al.*, (2018) carried out a research on comparative analysis

on existing animal intrusion detection system such as the physical barrier where the farmer erects wooden logs and bamboo sticks at the borders of their fields. Clearly this method proves to be almost useless as the barriers do not have the physical strength to resist animal attacks. Construction of brick walls is a good method but are very expensive to implement thus physical barriers are not efficient in protecting farmlands. Electric fences that are placed around the fields by some farmers could be illegal and very dangerous to humans and animals. Some farmers also result to manual surveillance, that is, they try to keep an eye on the whole farmland at the same time which is time consuming, highly inefficient and practically almost impossible. Due to this they could go as far as hiring people to watch over the field and therefore incur huge cost for the service and death due to confrontation with some intruders.

Computer vision is a branch of artificial intelligence based on the theory of machine learning, image processing and pattern recognition. It involves equipping the computer with cognitive ability to acquire, process, analyse, understand digital image acquired through cameras, extract features from it and make valid decisions based on the acquired images. Images acquired are enhanced, segmented and features extracted from the images are classified using classifiers such as Artificial neural networks and support vector machine (Rafael & Gonzalez, 2002). Artificial Neural Network (ANN) is inspired by biological neural systems and learns over time based on prescribed dataset using processes like geospatial, multispectral techniques and image processing techniques. While defining computing functions and distribution, the ANN sets out to look for the cost effective and ideal way of arriving at solution to a task (Technopedia, 2018).

This research seeks to combine Deep Learning using precisely Faster Regions with Convolution Neural Network (faster R-CNN) and Raspberry pi to develop a system that can detect intrusion with the use of an Infra-red (IR) sensor. It could also recognize the intruder through images that will be captured by cameras. For a human intrusion an alert system goes off through an audio output while for an animal intrusion, electronic repellent sounds are given out from the audio output to ward off the animal and at the same time a text message is sent to the owner of the farmland through a GSM Modem to alert the farmer about the intrusion. The rest of this paper is organized as follows. Section 2 presents literature review, Section 3 discusses the proposed methodology, while Section 4 concludes and opens the next course of the research.

## 2.0 LITERATURE REVIEW

This section presents review of some fundamental concepts of farmland vandalization and related works on intelligent system for both surveillance and protection of farmlands.

### 2.1 FARMLAND INTRUSION AND VANDALIZATION

A farm is an area of land that is devoted primarily to **agricultural** processes with the primary objective of producing **food** and other **crops**. The name is used for specialised units such as **arable farms**, vegetable farms, fruit farms, **dairy**, **pig** and **poultry farms**, and land used for the production of **natural fibres** and **biofuel**. It includes **ranches**, **feedlots**, **orchards**, plantations and estates, smallholdings and hobby farms, and includes the farmhouse and agricultural buildings as well as the land. Studies on land conflict in Nigeria indicate that the majority of violence in the Middle Belt is due to land issues. Of the violent deaths related to land issues in the Nigeria Watch database, 58.4% (1657 out of 2839) occurred in the Middle Belt from June 2006 to May 2014. The Nigeria Watch database indicates that between 2006 and

2014, violent deaths over land issues and cattle grazing accounted for only 3.79% of all violent deaths across the country.

## 2.2 FARMLAND INTRUSION AND VANDALIZATION PREVENTION TECHNIQUES

Various techniques have been reported in literature for detecting intrusion and preventing vandalization as shown in Figure 1. The available techniques can be grouped into:

- i. Manual Techniques
- ii. Automated Technique

### 2.2.1 Manual Technique

This technique involves a physical control which include the use of scarecrows, clothes tied to sticks and placed on the forms. Also, farmers

adopt methods like hatchery wastes by using spraying mixtures on the farmland such as egg contents mixed with water which releases a pungent smell when exposed to air.

### 2.2.2 Automated Technique

This technique makes use of computerized means to identify and detect intrusion and prevent vandalization on farm lands. The method involves, gathering information about the farms, storing the information gathered, extracting features from them and afterwards using the extracted features to ward off or cause an alert on the farm land. The devices from this approach can be mounted and used on the farm land for intrusion detection and vandalization prevention.

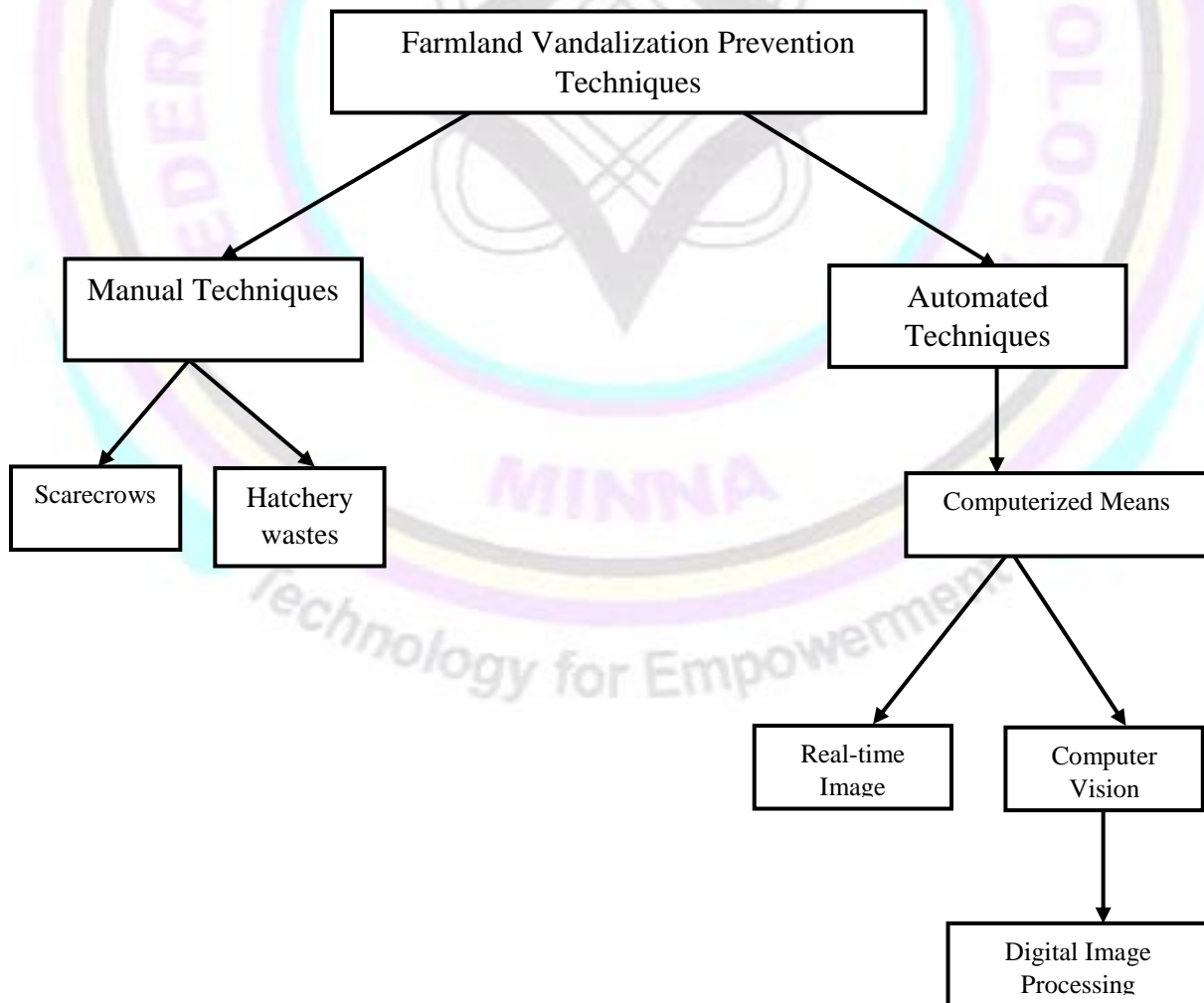




Figure 1: Classification of Farmland Vandalization Prevention Techniques.

One of the necessary conditions for a system to be Intelligent is that it must be able to interpret information, comprehend the relations between the phenomena or objects, perform meaningful operations and can apply the acquired information to changing set of conditions.

An intelligent system is not only adaptive, self-learning, fault-tolerant, self-organized & self-repairing at every level of hierarchy, but also capable of dealing with uncertainty. Intelligent systems are touching almost all aspects of our life. They find their application in robotics, data processing, business and finance, smart phones, expert systems and in agriculture in the form of precision farming.

### 2.3 RELATED WORKS

Sugumaran *et al.*, (2017) developed a smart surveillance monitoring system using raspberry pi and PIR sensor. This system uses a raspberry pi model b, webcam and PIR sensor for surveillance. The system provides surveillance and storage for the information collected but does not recognize object nor prevents intrusion. Chinmaya *et al.*, (2017) developed a smart surveillance system using raspberry pi and face recognition. A Raspberry pi camera module is used to capture images once motion is detected by the PIR sensor. It checks faces in the image captured with face recognition and alerts if the face detected is not stored in the database. The system recognizes object appropriately, but though the intruder is recognized, the intrusion is not prevented. Dugyala & Ramesh (2017) developed a smart crop protection system with image capture over internet of things. Their system uses a camera, Passive Infrared (PIR) sensor, a buzzer and Raspberry pi to capture image, detect motion and alert the owner respectively. The system only captures the

image of the intruder thereby providing evidence for the farm owner but it does not prevent intrusion.

Yogita & Khadke (2016) used the application of raspberry pi and PIR sensor for monitoring. The system captures information and transmits it through a 3G modem to a smart phone using web application with a Raspberry pi as the brain of the system. Though the system provides surveillance about the implemented boundary, it does not recognize object nor prevents intrusion. Pooja & Mohmad, (2016) developed a smart farmland using raspberry pi for crop vandalization prevention and intrusion detection. The system automates the process of keeping off wild animals from farmlands using electronic firecracker and rotten egg spray with a surveillance (camera) and differentiating between authorized and unauthorized users using RFID tags. Though the system is able to differentiate between authorized and unauthorized users and also wards off animal intrusion, it does not provide a real time monitoring and notification. Similarly, Ajayi & Olaifa (2016) developed a system that detects intrusion in large farmlands and plantations in Nigeria using virtual fencing. The system uses a PIR sensor to detect motion and a module to keep log of time and also provides internet connectivity. The system provides and keeps log of time but it does not recognize objects and does not prevent intrusion from occurring.

Alexei & Nishant (2015) developed a virtual fence based on infra-red break beams. The system uses a wireless sensor node equipped with infra-red transmitters and receivers which provides a flexible mechanism for monitoring crossings in and out of a designated region. The

system was able to provides 24/7 surveillance on the designated region/ boundary but it does not recognize object nor does it prevent intrusion. Similarly, Sanjana et al. (2014) developed a smart surveillance monitoring system Using Raspberry pi and PIR sensor. The proposed home security system captures information and transmits via a 3G Dongle to a smart phone using web application. The system only provides surveillance but it does not prevent intrusion. Chan *et al.*, (2014) carried out a performance study of virtual fence unit using wireless sensor network (WSN). The system uses an Octopus2 sensor nodes to develop a WSN platform and HB10 (microwave) to detect motion. The system provides surveillance but does not recognize objects nor does it prevent intrusion.

From the papers reviewed, some of the notable inadequacy of the existing systems include their inability to detect intrusion, prevent the intruders and alert the farmer and relevant authorities in real time. Hence, this paper proposes an intelligent farmland intrusion detection and vandalization prevention system using a faster R-CNN for real time detection, recognition and alerting the owner of the farmland.

### **3.0 MATERIALS AND METHODS**

#### **3.1 SYSTEM OVERVIEW**

The proposed intelligent farmland system consists of four (4) modules; the object detection module where any intruder is detected using four (4) IR sensors. The sensors were designed to be placed around the four corners of the farmland as shown in the proposed architecture of the system in Figure 2. The object recognition module is activated to take images of detected intruders using four pi-cameras each placed at the boundary of the farmland. The captured image is sent to the central control unit (Raspberry pi) for processing and recognition. A

faster convolution neural network (CNN) algorithm, a type of deep artificial neural network will be used for training the dataset. The trained network will be stored within the programmed Raspberry pi. Both animals and human are designed to be recognized and once the system detects that an intrusion is by an animal, the control unit sends a message to the prevention module. The prevention module comprises of electronic repellent like the ultrasonic electronic repellent which is silent to humans, but which is of high frequency sound wave and audible predatorial noise to scare away the animals. For human intruders and animal intruders, the system is designed to send a notification to the farm owner and relevant authorities through the alert module and sound alarm to alert any nearby person. Also, the images captured will be sent to a cloud storage through which relevant authorities and the farm owner can see the images of the intruders. Figure 3 shows the methodology of the proposed system, that is, the step by step procedures to be followed in order to achieve the aim of this paper.

#### **3.2 DATA ACQUISITION AND PREPARATION**

Several images of human and animals such as cattle, goat, sheep and pigs will be captured and used to train the CNN and test the network generalization capability. A sample image of a farm with a human intruder taken with a 13 Megapixel camera with a resolution of 4160 X 3120 pixel is shown in Figure 4. Preparing the data puts it in a suitable format for easy training and testing of the CNN. The size of the images will be reduced to a smaller size and pixel for efficient hardware deployment.

A data preparation tool called label image was used to draw a rectangular bounding box around the object of interest in the image and was labelled as either human or animal. The labelled

images will be saved as the dataset for the training and testing the object recognition model.

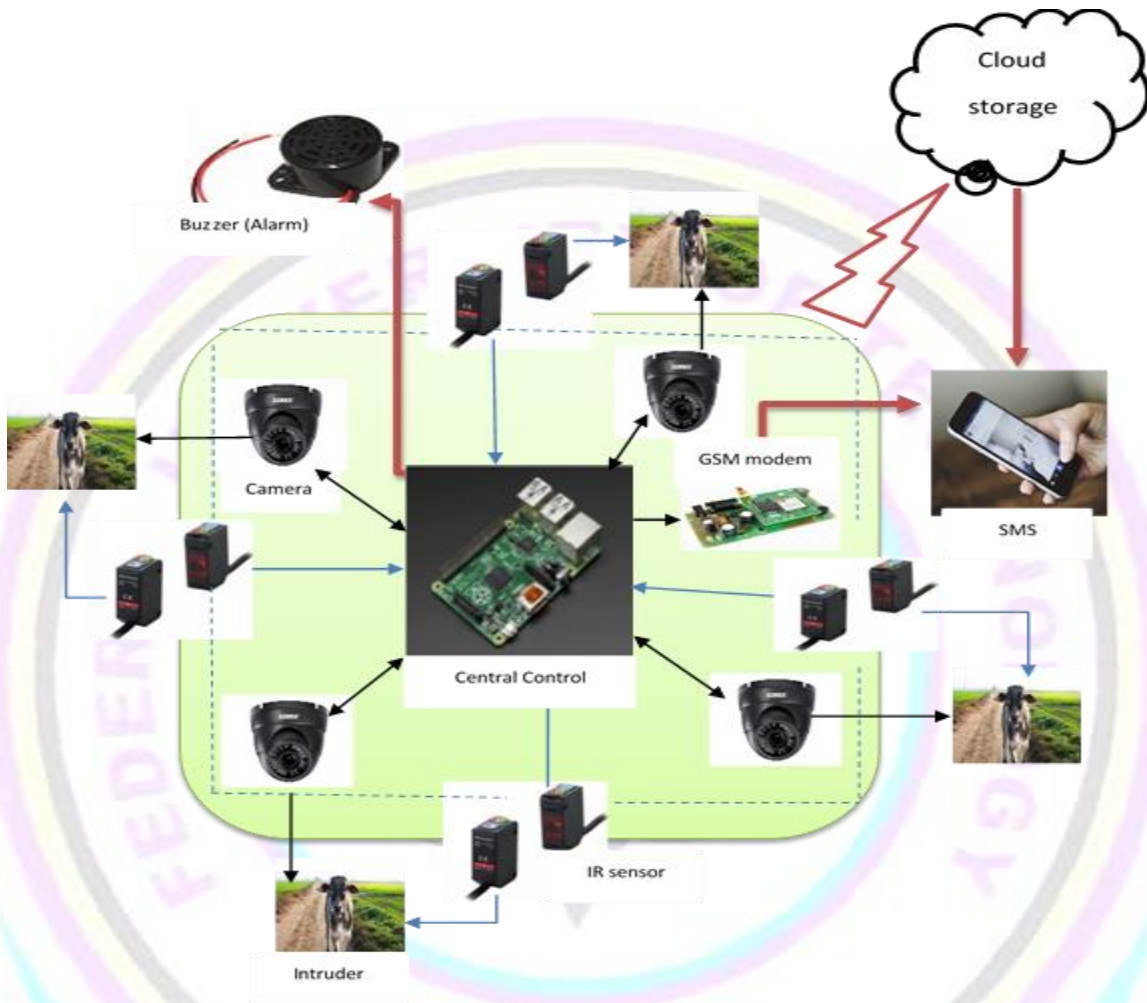


Figure 2: Proposed architecture of the intelligent farmland

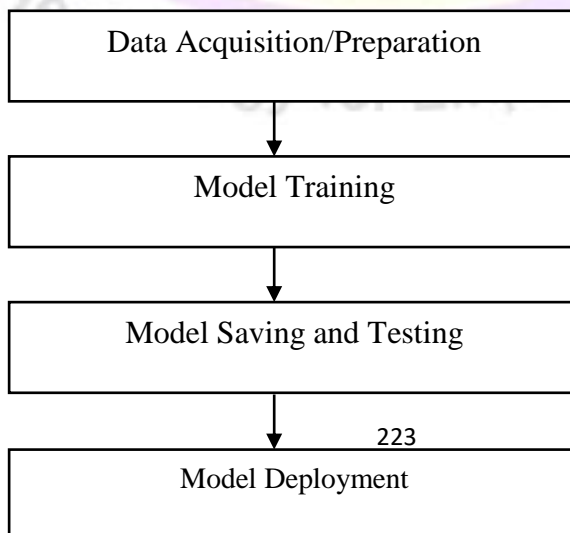




Figure 3: Proposed research methodology



Figure 4: Image of human on farmland obtained from FUTminna farm

### 3.3 TRAINING THE OBJECT RECOGNITION MODEL

An online Graphics Processing Unit (GPU) will be used for training the model. GPU's are necessary for training deep learning models

because they require a lot of computational power to run on, considerable hardware to run efficiently. Figure 5 is a sample diagram of a deep neural network showing the inputs, weights, threshold and output.

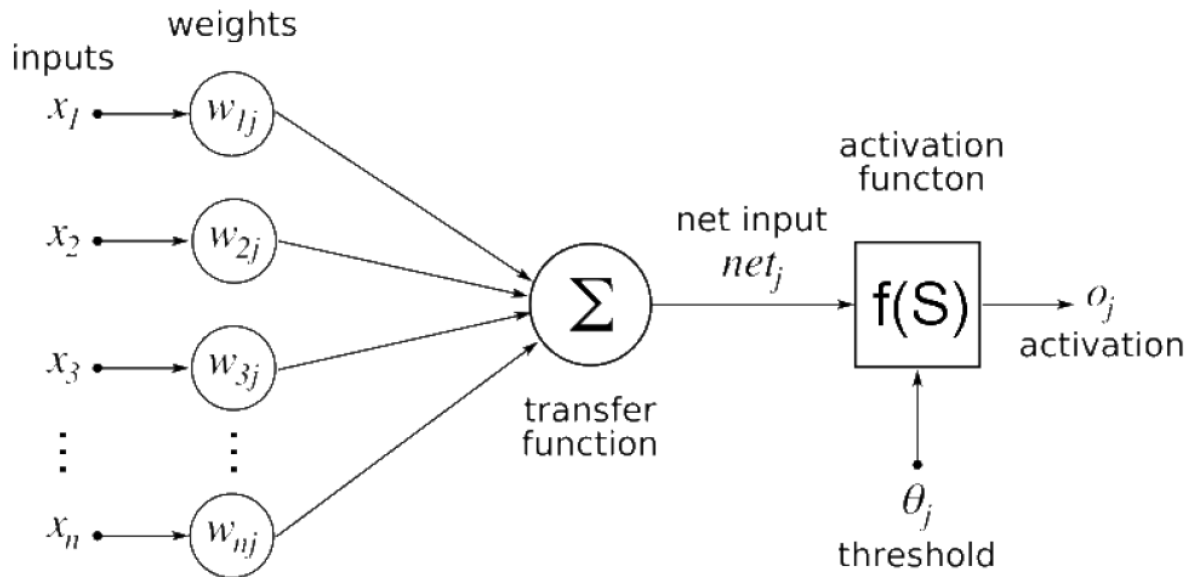


Figure 5: Typical Neural Network process (Shaikh, 2017).

#### 4.0 CONCLUSION AND RESEARCH DIRECTIONS

In this paper, an intelligent farmland intrusion detection and vandalization prevention system using deep learning is proposed. Various farmland intruder detection and vandalization prevention techniques in literatures were reviewed. Effort is in progress to acquire datasets that will be used to train and test the proposed CNN for image recognition. The trained model and other components will be deployed in a raspberry pi hardware. Tests shall be carried out at FUTMINNA Farm to determine the effectiveness of the system. At this stage, the research is open to criticisms and recommendations.

#### REFERENCES

- Adams, J. H. (1988). The Decoupling of Farm and Household: Differential Consequences of Capitalist Development on Southern Illinois and Third World Family Farms. *Comparative Studies in Society and History*(3), 453-482.
- Ajayi, O. (2016). Detecting Intrusion in Large Farmlands and Plantations in Nigeria Using Virtual Fences. *Annual conference* (pp. 1-11). University of Lagos: Olaifa O.
- Chinmaya, K., & Sanket, P. (2017). Smart Surveillance System using Raspberry Pi and Face recognition. *International Journal of Research in Computer and Communication Engineering*, 6(4), 621 - 624.
- Dahiya, Pawan., Chaudhary, Prachi., Saini, J., Kumar, S. (2007). Intelligent Systems: Features, Challenges, Techniques, Applications & Future Scopes. *Intelligent Systems & Mobile Adhoc Networks (ISMANET)*. Murthal.

- Retrieved August 31, 2018, from <https://www.researchgate.net/publication/280557943>
- Dugyala, K., & Ramesh, R. (2017). Smart crop Protection System with Image capture Over IOT. *International journal of Advanced Information Science and Technology*, 6(11), 37- 40.
- Gregor, H. F. (1969, July). Farm Structure in regional Comparison: California and New Jersey Vegetable farms. *Economic Geography*, 45(3), 209-225.
- G, Pooja. (2016). A Smart Farmland using Raspberry Pi Crop Vandalization Prevention. 5(1), 62-68.
- Koutoudis P. (2018). The importance of Agriculture for the Economy and the Specific Features of Mediterranean Agriculture, *Entrepreneurship news*.
- Rafael C. Gonzalez, R. E. W. (2002). *Digital Image Processing*. prentice hall upper saddle river, new jersey 07458: Tom Robbins
- Sugumaran, N., Vijay, G., & Annadevi, E. (2017). Smart Surveillance Monitoring System using Raspberry Pi and PIR Sensor. *International Journal of Innovative Research in Advanced Engineering*, 4(4), 11 - 15.
- Technopedia (Producer, 2018). Artificial Neural Network(ANN). *Technopedia Inc.* Retrieved from HYPERLINK "https://www.technopedia.com/definition/5967/artificial-neural-network-ann" <https://www.technopedia.com/definition/5967/artificial-neural-network-ann>
- [Trading Economics \(2018\), Nigerian GDP from Agriculture](https://tradingeconomics.com/nigeria/gdp-from-agriculture), Retrieved from <https://tradingeconomics.com/nigeria/gdp-from-agriculture>, retrieved September, 2018.
- TheHindu*. (2009, August 13). Retrieved from TheHindu Web site: <https://www.thehindu.com/sci-tech/agriculture/An-excellent-method-to-ward-off-wild-animals/article16874770.ece>
- Williams, A. A. (2018). Herdsmen and farmers Conflict in Nigeria: Another dimension of Insecurity. *Journal of Public Administration and Social Welfare Research*, 3. Retrieved from [www.iiardpub.org](http://www.iiardpub.org)
- Yogita, V., & Khadke, S. (2016). *Application of raspberry Pi and PIR Sensor for Monitoring of Smart Surveillance System*.



## EFFECTS OF BIOCHAR DERIVED FROM DIFFERENT FEEDSTOCK ON COWPEA PRODUCTIVITY IN MINNA, SOUTHERN GUINEA SAVANNA OF NIGERIA.

\*Adekanmbi,<sup>1</sup> A.A., Afolabi,<sup>1</sup> S.G., Umar,<sup>1</sup> A.O., Fagbenro,<sup>2</sup> J.A., Bala,<sup>1</sup> A. and Osunde,<sup>1</sup> O.A.

<sup>1</sup>Department of Soil Science and Land Management, Federal University of Technology, P.M.B 65, Minna, Niger State, Nigeria.

<sup>2</sup>Department of Environmental Management and Crop Production, Bowen University, Iwo, Nigeria

\*Author for Correspondence (email: [ade.kanmbi@futminna.edu.ng](mailto:ade.kanmbi@futminna.edu.ng); [alextonjil@yahoo.co.uk](mailto:alextonjil@yahoo.co.uk))

GSM:+2348053030696

### ABSTRACT

Evaluating the crop response to different biochar type could be a necessary step in adapting biochar technology into the current intensification of legume production in the savanna region of Nigeria. A pot experiment was conducted to evaluate the effect of biochar derived from different feedstocks on cowpea growth and nodulation, in Minna, Nigeria. The experiment was a 4 × 5 factorial experiment consisting of four (4) biochar types made from different feedstock at five (5) application rate and fitted into a completely randomized design (CRD) at three (3) replicates. The Four biochar types were; poultry manure, swine dung manure, sawdust and maize cob biochars and the five different application rates were; 0 tons ha<sup>-1</sup>, 0 tons ha<sup>-1</sup>+30 kg P ha<sup>-1</sup>, 5 tons ha<sup>-1</sup>, 10 tons ha<sup>-1</sup>, and 15 tons ha<sup>-1</sup>. The results showed that, applying biochar made from Poultry manure and Swine dung increased cowpea height and number of leaves compared to biochar made from sawdust and maize cob. Amending soil with biochar at the rate of 10 or 15 tons/ha led to taller plants and more numerous leaves similar to that of 0 tons/ha+30 kg P ha<sup>-1</sup>, whereas, 0 tons/ha gave shorter plants with fewer leaves over the growing period. Application of biochar derived from poultry manure increased the Shoot, root, nodule, and total biomass, shoot/root ratio, root length, number and percentage of effective nodules compare to the other biochar types. Applying biochar at 15 tons/ha significantly increased all the above and below ground biomass similar to that of 0 tons/ha+30 kg P ha<sup>-1</sup>. The significant interaction between biochar type and rate showed that application of biochar at rate up to 10 or 15 tons/ha of manure based biochar could replace the use of 30 kg P ha<sup>-1</sup>. This study have found that, manure based biochar have potential to improve cowpea growth and productivity at 10 tons/ha. There is need to re-examine this effects in a field trial to validate this recommendation.

Keywords: Cowpea, nodulation, biochar, feedstock, Soil Amendment

### INTRODUCTION

Cowpea (*Vigna unguiculata* L Walp) which comes from the family *fabaceae* and is a native to Africa is one of the most important crops grown in the arid and semi- arid regions of the tropics covering Asia, Africa, Southern Europe and Central America (Xu *et al.*,2016). In today's world, man's need for protein makes cowpea an irresistible option for food as cowpea provides a cheap source of human dietary protein especially in developing counties (Xu *et al.*,2016) and also produces a large biomass used in agriculture either as feed for animals or incorporated into soil to enhance soil fertility. Cowpea has also gained the interest of rural farmers due to its ability to adapt to the drier regions in the tropics because it fixes atmospheric nitrogen into the soil through a process called biological nitrogen fixation (BNF).

Through biological nitrogen fixation nitrogen gas (N<sub>2</sub>) present in the atmosphere is fixed and turned into readily available nitrogen for the preceding plant's uptake with the aid of soil micro-organism like rhizobia. This process is fostered by a symbiotic relationship between microorganism and

the plant root. Nodules are produced on the root which helps fix atmospheric nitrogen into the soil and in turn the plant provides carbohydrates for the microorganisms. These nodules become home for the bacteria. Usually this process happens only after the plant has grown to a certain stage but before it reaches that stage it has to also take up nutrient from soil. Some of the factors affecting effective nodulation are effective uptake of nutrients, soil acidity etc. (Lehmann and Joseph 2009). Soil amendments (inorganic and organic) are known to improve the uptake of nutrients, increase soil fertility, improve soil quality and consequently increase crop growth and yield.

Biochar has been identified globally for its use as an organic soil amendment which helps in the enhancement of soil fertility, crop growth, water retention and movement in the soil and in soil pollution control (Etelvino *et al.*, 2015). Some other benefits of biochar is in raising the pH of the soil, attracting more useful microorganisms, improving the cation exchange capacity (CEC) and also acts as nutrient reservoir (Lehmann and Joseph 2009; Alfred *et al.*, 2015).

Biochar is a smooth and fine grained charcoal which has very high but stable organic carbon content. It is made through the heating of natural feedstocks in the presence of limited oxygen or by pyrolysis and it is used today worldwide as a soil amendment (Egambiedieva *et al.*, 2016). Naturally it contains all trace elements that were originally contained in the pyrolysed, biomass (Lehman and Rondon 2006). Biochar is made from different feedstocks ranging from livestock waste, poultry litters down to wooden materials like shaving, and plant residue (e.g. straws, leaves, nuts, hulls, shells). There is a key difference between biochar made from different feedstock as some still retains some of their nutrients. Livestock biochar are chemically distinct from other biochar (wood, crop residue) because of the high nutrient content and are similar to the conventional fertilizer (Filberto and Guant, 2013).

Due to the rapid population growth of Nigerians' population and the need to increase agricultural productivity, food security and sustainability, increased agricultural practices has resulted in repeated harvest which slowly leads to rapid nutrient depletion, soil erosion, limited, organic matter; soil degradation, limited agricultural land and low cation exchange capacity (CEC) (Bot and Benites, 2005). Inorganic fertilizer has been the major soil amendment used since the dawn of industrial age. However, has its limitations on microorganisms when applied in ignorance, sometimes results in leaching and also encourages depletion of good and natural soils in the long run (Odesola and Owoseni 2010). It may exert adverse effect to the environment by contributing to the greenhouse gas emission (Jyoti *et al.*, 2013). Organic manure is also used as amendment of soil to increase soil productivity, plant productivity and also help in water retention and enhancement of microbial activity. But organic manure also has a high decomposing rate and hardly stays long in the soil. It also needs to be applied in a great quantity and it may also have -adverse effect in the environment by contributing to the greenhouse effect (Muhammed *et al.*, 2015)

Biochar, a soil amendment is relatively cheap because it processed from feedstocks and also and waste products that are locally sourced. This amendment used for improving soil properties and the subsequent crop growth, provides potential for carbon storage strategy in the soil and also sequester carbon which in turn reduces global warming (Josiah *et al.*, 2010). A Biochar characteristic vary due to its feedstocks and there is limited understanding of which biochar type and at what rate is most effective on cowpea growth and nodulation characteristics. Several studies have shown that an improvement in the growth of legumes effected by biochar application is strongly linked to the relationship between the roots

associated soil microorganisms and biochar. This is because biochar usually promotes a favourable condition for microbial proliferation (Egambardieva *et al.*, 2016). There may be a synergistic effect of applying biochar to soil as it may enhance the activity of the native rhizobia population and consequently enhance cowpea nodulation and nitrogen fixation. The aim of this study is to examine the effects of biochar derived from different feedstock (swine dung manure, poultry, sawdust, maize cob) on cowpea productivity in Minna, southern Guinea savanna of Nigeria.

## **MATERIALS AND METHODS**

### **Study site**

The soil used for the experiment was collected from the Teaching and Research Farm School of Agriculture and Agricultural Technology, Federal University of Technology, Gidan-Kwano Minna (latitude of 9° 31' 2.736" N, longitude 6° 26' 22.548" E, altitude 189.60 m above sea level). The pot experiment was carried out at the school' horticultural garden (latitude of 9° 31' 48.762" N, longitude 6° 27' 0.594" E, altitude 262.40 m above sea level). Minna is located in the southern guinea savanna of Nigeria. It has a mean annual rainfall of 1248mm and a sub humid climate. It is also characterized by a dry season of about 5 months occurring from November to March and also has its mean maximum temperature of 33.5°C from March to June (Ojanuga, 2006). Some of the physical characteristics of Minna area are the presence of gently undulating high plains which is developed on the basement of complex rocks made up of granites, migmatites, gneisses and schists , inselbergs of " older granite" and also low hills of schists which rises conspicuously above the plains beneath the plains bedrock and is deeply weathered. This constitutes the major part of the parent material (saprolites) (Ojanuga 2006).

### **Collection and preparation of soil sample**

The soil sample was collected from the study site at from a depth of 0 -15cm within an area of 1m by 2m. A shovel was used in the collection of the soil after which the soil was mixed thoroughly, air dried and passed through a 2mm sieve to remove stones and gravels from the soil. Samples for pre- planting analysis were taken from the collected bulk soil. The collected soil was transferred in bags to the horticultural garden.

### **Treatment and experimental design**

The experiment was a 4 x 5 factorial experiment which consisted of four biochar types and 5 rates fitted into a completely randomised design (CRD) with three replicates.

The four biochar types used were swine dung biochar, poultry biochar, sawdust biochar, maize cob biochar. The biochar rates used were; 0 tons ha<sup>-1</sup>, 0 + 30 kg P ha<sup>-1</sup>, 5 tons ha<sup>-1</sup>, 10 tons ha<sup>-1</sup>, 15 tons



ha<sup>-1</sup>. The quantity of soil per pot used was 2.5 kg of soil while the total number of treatments was 60.

#### **Procurement of seeds and biochar**

The variety of cowpea seeds used for the experiment was IT99K-573-1-1 and this was sourced from The International Institute of Tropical Agriculture (IITA) Ibadan, Oyo, Nigeria. The biochar used were sourced from Bowen University Iwo. These included biochar made from swine dung, poultry biochar, sawdust and maize cob. These biochar were characterised at Federal University of Technology Minna, Niger State. The chemical properties of biochar derived from different feedstocks are shown on Appendix 1

#### **Laboratory analysis of the soil**

The physical and chemical properties of the sieved soil were analysed in accordance to the standard method described by Agbenin (1995). Particle size of soil was determined using the hydrometer method. Soil pH was measured in 1:2.5 soil/water and 0.01M CaCl<sub>2</sub> suspension with a pH meter. Organic carbon was determined by the Walkley-Black wet oxidation method. The available phosphorous was determined colorimetrically after Bray-Pl extraction. The exchangeable bases were extracted with a neutral 1N NH<sub>4</sub>OAC solution. Na<sup>+</sup> and K<sup>+</sup> in the leachate were determined by flame photometry while Ca<sup>2+</sup> and Mg<sup>2+</sup> were determined by Na-EDTA titration. The exchangeable acidity was extracted by 1.0 N KCL. Effective cation exchange capacity was obtained by the summation of exchangeable cations and the exchangeable acidity. Total nitrogen was determined by micro kjeldahl method. A detailed description of the procedure used for the physical and chemical analysis of the soil is given in the appendix.

#### **Agronomic practice**

The site where the pots were arranged was cleared manually using hoes to remove grasses and stumps. Jute bags were laid on the ground and polypots were placed on them. The air dried soil was weighed and mix thoroughly with different biochar types and at different rates i.e. 5, 10, 15 tons ha<sup>-1</sup> and three replicates was transferred into well plugged polypots. Water was added at 40% water holding capacity (WHC) and left to equilibrate for three days. Control pots i.e. 0 tons per hectare was also treated as pots with biochar while in pots for single super phosphate i.e.0+ 30kg P ha<sup>-1</sup>, the mineral fertilizer was dissolved with water and applied at the same time and rate applied to others. Sowing was carried out immediately after equilibration. Planting stick was used to make a hole in each pot at a depth of 2.5cm and 3 seeds were planted per poly pot. After one week of

emergence, thinning was done plants were thinned to one plant per pot.

#### **Measurement of growth and nodulation characteristics**

Plant heights (cm) were measured using a tape rule at 4, 6 and 8 weeks after sowing (WAS) from all the treatment pots during the growth period. Leaves were counted alongside the plant heights at 4, 6 and 8 (WAS) and the values were recorded for each biochar type and rate. After 8 weeks of planting, plants were harvested using a sharp scissor to cut the shoot from the plant base. The roots (contained in an intact ball of earth) were immediately washed in a 2mm sieve using water to remove soil and also to prevent detached nodules from entering into the water. Nodules were separated from the roots for counting. Shoot weight in grams (g) was immediately measured after harvesting and was also taken after drying in an oven regulated at 75<sup>o</sup>C to a constant weight for 48 hours. The weight was measured using an electronic weighing balance. The root length (cm) was measured immediately after harvesting using a metre rule for each individual biochar type and rate. Root weight (g) was taken immediately after harvesting and was also taken after drying in an oven regulated at 75<sup>o</sup>C to a constant weight for 48 hours. The weight was also measured using an electronic weighing balance. Nodules were counted immediately after harvesting and the value were recorded for each biochar type and rate after which nodules weight (g) was measured immediately after harvesting and was also taken after drying in an oven regulated at 75<sup>o</sup>C to a constant weight for 48 hours, as in shoot and root measurement. The percentage effectivity of the nodules was also checked after counting by selecting 5 nodules at random and was cut using a sharp razor blade. Those with pink to reddish-brown colour were recorded as effective while those with green or dark colour were ineffective. The percentages of the number with effective nodules were recorded.

#### **Statistical analysis**

All data collected were subjected to Analysis of Variance (ANOVA) using Minitab 17.0 version. Where mean differences are observed, Fishers pairwise comparism was used to separate the means at 5% level of significance.

## **RESULTS AND DISCUSSION**

The result of the physical and chemical properties of the soil used for the experiment was shown on Table 1. The soil was loamy sand. The soil pH was slightly acidic. The organic carbon (2.72 g kg<sup>-1</sup>) and total nitrogen (0.003 g kg<sup>-1</sup>) were low. The calcium (3.34 cmol kg<sup>-1</sup>) and potassium (0.33 cmol kg<sup>-1</sup>) contents were low. The available phosphorus (12 mg kg<sup>-1</sup>) and magnesium (2.33 cmol kg<sup>-1</sup>) contents were moderately available.



The main effects of biochar type and rate on plant height and number of leaves of cowpea at 4, 6 and 8 WAS were shown on Table 2. The application of the different biochar types showed a significant effect ( $P < 0.05$ ) on the plant height of cowpea at 4, 6 and 8 WAS. Poultry manure biochar and swine dung biochar produced taller plants compared to sawdust biochar and maize cob biochar at 4, 6 and 8 WAS (Table 2). There was no significant difference ( $P > 0.05$ ) between the biochar rates on cowpea plant height at 4 WAS. Application of 10 and 15 tons  $\text{ha}^{-1}$  produced statistically taller plants at 6 and 8 WAS compared to the control.

The application of the different biochar types had a significant effect ( $P < 0.05$ ) on the number of leaves of cowpea. Poultry manure biochar produced the highest number of leaves which was significant different ( $P < 0.05$ ) from sawdust and maize cob biochar at 6 and 8 WAS (Table 2). Application of 10 and 15 tons  $\text{ha}^{-1}$  produced higher number of leaves which is significantly different from 0 and 5 tons  $\text{ha}^{-1}$  at 4 and 6 WAS but similar to 0+30kg P  $\text{ha}^{-1}$  at 4 WAS (Table 2).

The interaction effect of both biochar types and rates on the height of cowpea at 6 and 8 WAS were shown on Table 3 and the interaction effect of both biochar types and rates on the number of leaves of cowpea at 4, 6 and 8 WAS were shown on Table 4.

The interaction effect of biochar types and rates on the number of leaves at 4 WAS revealed that 10 tons  $\text{ha}^{-1}$  of poultry manure biochar produced the highest number of leaves compared to other treatments, similar results was observed at 6 WAS. The result was similar to poultry manure biochar at 15 tons  $\text{ha}^{-1}$ . Poultry manure biochar applied 15 tons  $\text{ha}^{-1}$  produced the highest number of leaves than other biochar types and rates.

There was a significant effect ( $P < 0.05$ ) of biochar types on the shoot weight of cowpea with biochar made from poultry manure having the highest shoot weight, root weight and total biomass. Swine dung biochar was significantly difference from other sources of biochar applied (Table 5). The animal derived biochar was significantly higher than the maize cobs and sawdust biochar in terms of shoot/root ratio, root length and number of nodules of cowpea. Application of 15 tons  $\text{ha}^{-1}$  had significant difference ( $p < 0.05$ ) than other rates of biochar and 0 + 30 kg P  $\text{ha}^{-1}$  (Table 5).

The interaction effect between biochar types and rates on the shoot weight of cowpea revealed that the effect of poultry manure biochar at 10 and 15 tons  $\text{ha}^{-1}$  produced the highest shoot weight while the lowest shoot weight was observed at application of maize cobs biochar at 0 tons  $\text{ha}^{-1}$  (Table 6).

The interaction effect between biochar types and rates on the root weight of cowpea revealed that the effect of poultry manure biochar applied at 10 and

15 tons  $\text{ha}^{-1}$  produced the highest root weight which was significantly difference from other treatments. A similar result was observed on root length (Table 7).

The interaction effect between biochar types and rates on the number of nodules of cowpea revealed that the effect of poultry biochar applied at 5 tons  $\text{ha}^{-1}$  and swine dung at 15 tons  $\text{ha}^{-1}$  produced the highest nodule number which was significant difference from other treatments (Table 8). The interaction effect between biochar types and rates on the weight of nodules of was shown in Table 8. Application of poultry manure at 15 tons  $\text{ha}^{-1}$  produced the heavier nodule weight which was similar to 10 tons  $\text{ha}^{-1}$  while the lightest was observed when sawdust and maize cobs was applied at 0, 5 and 10 tons  $\text{ha}^{-1}$  (Table 8).

Biochar has been reported to generally improve the biomass of leguminous crops at all stages of growth (Lehmann and Joseph, 2009). Results from this study have shown that, poultry manure followed by swine dung biochar produced taller cowpea plants and numerous leaves, but maize cob biochar and sawdust biochar consistently produced shorter plants and fewer leaves. This may be due to the difference in the chemical composition of the individual feedstock (Filberto and Guant 2013). Filberto and Guant (2013) also reported that animal derived biochar produced higher amount of calcium, potassium, nitrogen and phosphorous which sometimes may be similar to conventional fertilizer.

Biochar feedstock derived from animal manure greatly influences the height and number leaves of cowpea and this may be due to increase availability of nutrients for plant uptake. Since it increases the number of leaves which acts as site for photosynthetic activities it can then be said that biochar affects the rate of photosynthesis of plant. Agboola and Moses (2015), also reported that an application of biochar affects the photosynthetic effect of legumes. Application of 0+ 30 kg P  $\text{ha}^{-1}$  also produced tall cowpea plants with a reasonable number of leaves but not as much as 10 and 15 tons biochar  $\text{ha}^{-1}$  which indicates that cowpea is a phosphorous loving crop and an application of no biochar with 30 kg P alone cannot give the optimum yield required of cowpea (Nehls, 2002). The chemical nature of the feedstocks as biochar made from poultry manure increases the soil pH because of its alkaline nature, hence it provides a favourable environment for cation exchange. Although maize cob biochar was also alkaline in nature, the chemical nature of the feedstock may be the reason for its poor output even when it was applied at 10 and 15 tons  $\text{ha}^{-1}$  (Lehmann and Joseph, 2009).

The highest positive effects were observed at the application of poultry manure biochar on the shoot

weight, root weight, root length, shoot-root ratio, total biomass, number of nodules, nodule weight and effectivity. There was a partitioning effect that favours the above rather than below ground biomass when Swine dung biochar and poultry manure biochars were added to the soil and this was better represented by the shoot-root ratio. This effect is logical in terms of crop growth since good biomass accumulation is required to achieve better yield. Animal manure derived biochars also produced the longest roots and the highest number of nodules of cowpea. This may be due to the individual nature of feedstocks and higher nutrient content of biochar made from livestock as biochar made from livestock contains high minerals like calcium, phosphorus and total nitrogen, this could enhance the growth of roots and better ability to forage for more nutrients and moisture and also produce nodules for BNF (Filberto and Guant, 2013). Agboola and Moses, (2015), noted that, although addition of biochar significantly affects the root length, shoot weight, root weight, nodule number, weight and effectivity in legumes, biochar types significantly affect ability of biochar to enhance legumes growth.

The application  $0+30\text{ kg P ha}^{-1}$  which serves as a fertilizer control in this study produced the longest roots and highest percentage effective nodules. This indicates that phosphorus is very important in the development and infestation of cowpea root by native rhizobia. But a similar effect was observed with the application of  $15\text{ tons biochar ha}^{-1}$ . This may mean that biochar applied at  $15\text{ tons ha}^{-1}$  can substitute for the application of  $30\text{ kg P SSP}$  which was the major fertilizer requirement of cowpea in the area. An application of biochar at 10 and 15 tons biochar  $\text{ha}^{-1}$  had similar effects on shoot-root ratio, nodule weight, number and root weight which were the highest. These effects may be due to the formation of more effective nodules as pH improves. This implies that legume growth

may benefit from biochar addition to enhance the biochemistry of the soil environments which may influence the root length, shoot weight, root weight, nodule number, weight and effectivity. It is also evidenced that the ability of biochar to enhance legumes growth is significantly by the biochar rates as biochar applied below  $10\text{ tons ha}^{-1}$  did not support growth appropriately. Poultry manure biochar applied at both  $10\text{ tons biochar ha}^{-1}$  and  $15\text{ tons ha}^{-1}$  produced the highest effects on shoot weight, total biomass and root weight in this study while it was noted that poultry manure biochar applied at  $15\text{ tons biochar ha}^{-1}$  produced the highest effect on nodule weight. This may be due to the increasing availability of nutrient by biochar. Poultry manure biochar applied at 10 and 15 tons biochar  $\text{ha}^{-1}$  produced a similar root length with those of  $0+30\text{ kg P ha}^{-1}$ . This indicates that, though cowpea is a phosphorus loving crop, an application of poultry manure biochar at 10 and 15 tons  $\text{ha}^{-1}$  can directly substitute for the application of  $30\text{ kg P ha}^{-1}$  (Singh *et al.*, 2010). It was reported that biochar made from livestock, when applied in the appropriate quantity can increase the availability of nutrient present for plant uptake.

#### CONCLUSION

In conclusion, poultry manure biochar produced the most outstanding effects on the overall growth and nodulation characteristics of cowpea while mostly biochar applied at  $10\text{ tons ha}^{-1}$  and  $15\text{ tons ha}^{-1}$  had the most positive influence on the overall growth of cowpea. The addition of poultry manure biochar applied at 10 and 5 tons had the greatest influence on cowpea productivity which can be compared with P application  $30\text{ kg P ha}^{-1}$ . There is however an urgent need to conduct further studies to access the effect of poultry manure biochar applied at  $10\text{ tons ha}^{-1}$  on the production of cowpea under field conditions to validate this view.

**Table 1. Physical and Chemical Properties of the Soil used for the experiment**

Parameters	Values
Sand (g kg <sup>-1</sup> )	809.4
Silt (g kg <sup>-1</sup> )	56.4
Clay (g kg <sup>-1</sup> )	134.2
Textural class	Loamy sand
pH (1: 2.5) H <sub>2</sub> O	6.20
Organic Carbon (g kg <sup>-1</sup> )	2.72
Total Nitrogen (g kg <sup>-1</sup> )	0.003
Available phosphorus(mg kg <sup>-1</sup> )	12
Exchangeable Bases (cmol kg <sup>-1</sup> )	
Ca <sup>2+</sup>	3.34
Mg <sup>2+</sup>	2.33
Na <sup>+</sup>	0.68
K <sup>+</sup>	0.33
Exchangeable acidity (cmol kg <sup>-1</sup> )	0.022
Effective Cation Exchange Capacity cmol kg <sup>-1</sup>	6.70

**Table 3. Interaction effects between biochar types and rates on plant height of cowpea at 6 and 8 WAS (cm plant<sup>-1</sup>)****Table 2.: Effects of Biochar types and rates on plant height and number of leaves of cowpea**

Treatments	Plant height			Number of leaves		
	4 WAS (cm plant <sup>-1</sup> )	6 WAS (cm plant <sup>-1</sup> )	8 WAS (cm plant <sup>-1</sup> )	4 WAS (No plant <sup>-1</sup> )	6 WAS ( No plant <sup>-1</sup> )	8 WAS ( No plant <sup>-1</sup> )
Biochar Type( T)						
Swine dung	23.17 <sup>ab</sup>	21.96 <sup>a</sup>	27.09 <sup>a</sup>	8 <sup>b</sup>	11 <sup>a</sup>	13 <sup>a</sup>
Poultry manure	24.48 <sup>a</sup>	23.38 <sup>a</sup>	30.26 <sup>a</sup>	10 <sup>a</sup>	13 <sup>a</sup>	14 <sup>a</sup>
Sawdust	20.25 <sup>c</sup>	18.3 <sup>b</sup>	18.81 <sup>b</sup>	7 <sup>b</sup>	8 <sup>b</sup>	9 <sup>b</sup>
Maize cob	21.87 <sup>bc</sup>	18.34 <sup>b</sup>	19.17 <sup>b</sup>	7 <sup>b</sup>	8 <sup>b</sup>	9 <sup>b</sup>
SE±	0.73	0.77	1.51	0.5	1	1
Biochar Rates ( R)						
0 tons ha <sup>-1</sup>	20.84 <sup>a</sup>	16.23 <sup>b</sup>	15.48 <sup>c</sup>	6 <sup>c</sup>	5 <sup>c</sup>	6 <sup>b</sup>
0+30 kg P ha <sup>-1</sup>	23.3 <sup>a</sup>	21.68 <sup>a</sup>	24.98 <sup>ab</sup>	9 <sup>a</sup>	11 <sup>ab</sup>	13 <sup>a</sup>
5 tons ha <sup>-1</sup>	22.48 <sup>a</sup>	19.96 <sup>a</sup>	22.34 <sup>b</sup>	7 <sup>b</sup>	9 <sup>b</sup>	12 <sup>a</sup>
10 tons ha <sup>-1</sup>	23.08 <sup>a</sup>	22.29 <sup>a</sup>	28.44 <sup>a</sup>	9 <sup>a</sup>	13 <sup>a</sup>	13 <sup>a</sup>
15 tons ha <sup>-1</sup>	22.86 <sup>a</sup>	22.32 <sup>a</sup>	28.04 <sup>a</sup>	9 <sup>a</sup>	14 <sup>a</sup>	14 <sup>a</sup>
SE±	0.82	0.86	1.69	0.5	1	1
T×R	NS	*	*	*	*	*

Means with the same letter in a column within the same treatments are not significantly different ( $p > 0.05$ )

\*= Significant interaction

NS= Not significant interaction



**Table 4. The interaction effect between biochar types and rates on the number of leaves of cowpea at 4, 6 and 8 WAS.**

Biochar types	Biochar rates (No plant <sup>-1</sup> )				
	0 tons ha <sup>-1</sup>	0+ 30kgP ha <sup>-1</sup>	5 tons ha <sup>-1</sup>	10 tons ha <sup>-1</sup>	15 tons ha <sup>-1</sup>
<b>4 WAS</b>					
Swine dung biochar	6 <sup>ghi</sup>	7 <sup>fghi</sup>	7 <sup>fghi</sup>	10 <sup>bcd</sup>	9 <sup>bcdef</sup>
Poultry biochar	5 <sup>hi</sup>	8 <sup>cdefg</sup>	10 <sup>bcde</sup>	15 <sup>a</sup>	12 <sup>b</sup>
Sawdust biochar	6 <sup>ghi</sup>	11 <sup>bc</sup>	6 <sup>ghi</sup>	5 <sup>i</sup>	7 <sup>fghi</sup>
Maize cob biochar	6 <sup>ghi</sup>	8 <sup>defgh</sup>	6 <sup>ghi</sup>	7 <sup>fghi</sup>	7 <sup>fghi</sup>
<b>6 WAS</b>					
Swine dung biochar	6 <sup>def</sup>	12 <sup>bc</sup>	13 <sup>b</sup>	13 <sup>bc</sup>	13 <sup>b</sup>
Poultry biochar	4 <sup>ef</sup>	9 <sup>bcdef</sup>	10 <sup>bcd</sup>	20 <sup>a</sup>	25 <sup>a</sup>
Sawdust biochar	6 <sup>def</sup>	12 <sup>bc</sup>	6 <sup>def</sup>	7 <sup>cdef</sup>	8 <sup>bcdef</sup>
Maize cob biochar	3 <sup>f</sup>	12 <sup>bc</sup>	6 <sup>def</sup>	11 <sup>bcd</sup>	9 <sup>bcde</sup>
<b>8 WAS</b>					
Swine dung biochar	7 <sup>ghij</sup>	13 <sup>cdef</sup>	15 <sup>bcd</sup>	12 <sup>cdefg</sup>	16 <sup>abc</sup>
Poultry biochar	5 <sup>ij</sup>	11 <sup>cdefgh</sup>	19 <sup>ab</sup>	15 <sup>bcd</sup>	21 <sup>a</sup>
Sawdust biochar	6 <sup>hij</sup>	13 <sup>cdef</sup>	8 <sup>efghij</sup>	12 <sup>cdefg</sup>	9 <sup>efghij</sup>
Maize cob biochar	4 <sup>j</sup>	13 <sup>cde</sup>	8 <sup>efghij</sup>	12 <sup>cdefg</sup>	10 <sup>defghi</sup>

Means with the same letter are not significantly different (p>0.05)

Biochar types	Biochar rates				
	0 tons ha <sup>-1</sup>	0+ 30kgP ha <sup>-1</sup>	5 tons ha <sup>-1</sup>	10 tons ha <sup>-1</sup>	15 tons ha <sup>-1</sup>
<b>6 WAS</b>					
Swine dung biochar	16.8 <sup>fgh</sup>	22.93 <sup>bcde</sup>	21.67 <sup>cdef</sup>	23.73 <sup>bcd</sup>	24.67 <sup>bc</sup>
Poultry biochar	15.87 <sup>gh</sup>	20.53 <sup>cdefg</sup>	23.23 <sup>bcd</sup>	29.63 <sup>a</sup>	27.63 <sup>ab</sup>
Sawdust biochar	17.6 <sup>fgh</sup>	21.63 <sup>cdef</sup>	18.13 <sup>efgh</sup>	16.43 <sup>gh</sup>	17.7 <sup>fgh</sup>
Maize cob biochar	14.67 <sup>h</sup>	21.6 <sup>cdef</sup>	16.8 <sup>fgh</sup>	19.37 <sup>defgh</sup>	19.27 <sup>defgh</sup>
<b>8 WAS</b>					
Swine dung biochar	16.83 <sup>gh</sup>	29.17 <sup>bcdef</sup>	24 <sup>cdefg</sup>	32.27 <sup>bcd</sup>	33.7 <sup>bc</sup>
Poultry biochar	13.8 <sup>h</sup>	24.53 <sup>cdefg</sup>	31.37 <sup>bcde</sup>	43.53 <sup>a</sup>	38.07 <sup>ab</sup>
Sawdust biochar	17.53 <sup>gh</sup>	22.07 <sup>efgh</sup>	17.27 <sup>gh</sup>	17.97 <sup>gh</sup>	19.2 <sup>gh</sup>
Maize cob biochar	13.77 <sup>h</sup>	24.17 <sup>cdefg</sup>	16.73 <sup>gh</sup>	20 <sup>fgh</sup>	21.2 <sup>fgh</sup>

Means with the same letter are not significantly different (p>0.05)

**Table 5.: Effects of biochar types and rates on the above, below ground cowpea productivity and nodule Characteristics**

Treatment	Shoot weight (g plant <sup>-1</sup> )	Root weight (g plant <sup>-1</sup> )	Total Biomass (g plant <sup>-1</sup> )	Shoot/Root ratio (plant <sup>-1</sup> )	Root length (cm plant <sup>-1</sup> )	Number of Nodules (plant <sup>-1</sup> )	Nodule weight (g plant <sup>-1</sup> )	Nodule effectivity %
BiocharTypes (T)								
Swine dung	1.63 <sup>b</sup>	1.11 <sup>b</sup>	2.73 <sup>b</sup>	1.44 <sup>a</sup>	26.45 <sup>a</sup>	16 <sup>a</sup>	0.07 <sup>b</sup>	66.67 <sup>b</sup>
Poultry manure	2.42 <sup>a</sup>	1.65 <sup>a</sup>	4.07 <sup>a</sup>	1.34 <sup>a</sup>	26.51 <sup>a</sup>	18 <sup>a</sup>	0.14 <sup>a</sup>	73.33 <sup>a</sup>
Sawdust	0.47 <sup>c</sup>	0.56 <sup>c</sup>	1.02 <sup>c</sup>	0.80 <sup>b</sup>	26.8 <sup>a</sup>	6 <sup>b</sup>	0.02 <sup>c</sup>	54 <sup>ab</sup>
Maize cob	0.54 <sup>c</sup>	0.69 <sup>c</sup>	1.23 <sup>c</sup>	0.75 <sup>b</sup>	22.12 <sup>b</sup>	6 <sup>b</sup>	0.02 <sup>c</sup>	40 <sup>b</sup>
SE±	0.18	0.10	0.23	0.15	0.99	2	0.01	7.87
Biochar rates (R)								
0 tons ha <sup>-1</sup>	0.17 <sup>c</sup>	0.31 <sup>b</sup>	0.48 <sup>d</sup>	0.71 <sup>a</sup>	18.27 <sup>d</sup>	1 <sup>b</sup>	0.0007 <sup>b</sup>	13.33 <sup>c</sup>
0+30 kg P ha <sup>-1</sup>	1.19 <sup>b</sup>	1.17 <sup>a</sup>	2.35 <sup>bc</sup>	1.03 <sup>a</sup>	31.76 <sup>a</sup>	15 <sup>a</sup>	0.07 <sup>a</sup>	88.33 <sup>a</sup>
5 tons ha <sup>-1</sup>	1.21 <sup>b</sup>	1.01 <sup>a</sup>	2.22 <sup>c</sup>	1.17 <sup>a</sup>	21.92 <sup>c</sup>	12 <sup>a</sup>	0.07 <sup>a</sup>	61.67 <sup>b</sup>
10 tons ha <sup>-1</sup>	1.76 <sup>ab</sup>	1.24 <sup>a</sup>	3.00 <sup>b</sup>	1.16 <sup>a</sup>	26.76 <sup>b</sup>	14 <sup>a</sup>	0.08 <sup>a</sup>	56.67 <sup>b</sup>
15 tons ha <sup>-1</sup>	2.00 <sup>a</sup>	1.28 <sup>a</sup>	3.28 <sup>a</sup>	1.35 <sup>a</sup>	28.64 <sup>ab</sup>	16 <sup>a</sup>	0.09 <sup>a</sup>	72.5 <sup>ab</sup>
SE±	0.2	0.11	0.25	0.17	1.10	2	0.01	8.8
T×R	*	*	*	NS	*	*	*	NS

Means with the same letter in a column within the same treatments are not significantly different (p>0.05)

\*= Significant interaction

NS= Not significant interaction



**Table 6. Interaction effect between biochar types and rates on the shoot weight (g plant<sup>-1</sup>) and the total biomass (g plant<sup>-1</sup>)**

Biochar types	Biochar rates				
	0 tons ha <sup>-1</sup>	0+ 30kgP ha <sup>-1</sup>	5 tons ha <sup>-1</sup>	10 tons ha <sup>-1</sup>	15 tons ha <sup>-1</sup>
<b>Shoot weight</b>					
Swine dung biochar	0.23 <sup>ef</sup>	1.37 <sup>cde</sup>	1.92 <sup>bcd</sup>	2.03 <sup>bcd</sup>	2.59 <sup>b</sup>
Poultry biochar	0.13 <sup>f</sup>	1.16 <sup>def</sup>	2.33 <sup>bc</sup>	4.06 <sup>a</sup>	4.43 <sup>a</sup>
Sawdust biochar	0.21 <sup>ef</sup>	1.34 <sup>def</sup>	0.35 <sup>ef</sup>	0.27 <sup>ef</sup>	0.37 <sup>ef</sup>
Maize cob biochar	0.12 <sup>f</sup>	1.08 <sup>ef</sup>	0.22 <sup>ef</sup>	0.66 <sup>ef</sup>	0.59 <sup>ef</sup>
<b>Total biomass</b>					
Swine dung biochar	0.73 <sup>f</sup>	2.34 <sup>cd</sup>	3.12 <sup>bc</sup>	3.46 <sup>bc</sup>	4.01 <sup>b</sup>
Poultry biochar	0.3 <sup>f</sup>	2.51 <sup>cd</sup>	4.35 <sup>b</sup>	6.3 <sup>a</sup>	6.9 <sup>a</sup>
Sawdust biochar	0.51 <sup>f</sup>	2.27 <sup>cde</sup>	0.77 <sup>f</sup>	0.72 <sup>f</sup>	0.84 <sup>ef</sup>
Maize cob biochar	0.35 <sup>f</sup>	2.28 <sup>cd</sup>	0.63 <sup>f</sup>	1.52 <sup>def</sup>	1.35 <sup>def</sup>

Means with the same letter in a column within the same treatments are not significantly different (p>0.05)

**Table 7. Interaction effect between biochar types and rates on the root length (cm plant<sup>-1</sup>) and root weight (g plant<sup>-1</sup>)**

Biochar types	Biochar rates				
	0 tons ha <sup>-1</sup>	0+ 30kgP ha <sup>-1</sup>	5 tons ha <sup>-1</sup>	10 tons ha <sup>-1</sup>	15 tons ha <sup>-1</sup>
<b>Root length cm</b>					
Swine dung biochar	26.17 <sup>cde</sup>	28.77 <sup>abcde</sup>	23.7 <sup>e</sup>	27.23 <sup>cde</sup>	26.37 <sup>cde</sup>
Poultry biochar	13.83 <sup>f</sup>	34.27 <sup>a</sup>	25.47 <sup>cde</sup>	28.17 <sup>abcde</sup>	30.83 <sup>abc</sup>
Sawdust biochar	23.57 <sup>e</sup>	33.87 <sup>ab</sup>	24.67 <sup>cde</sup>	24 <sup>de</sup>	27.9 <sup>bde</sup>
Maize cob biochar	9.5 <sup>f</sup>	30.13 <sup>abcd</sup>	13.87 <sup>f</sup>	27.63 <sup>bcde</sup>	29.47 <sup>abcde</sup>
<b>Root weight g</b>					
Swine dung biochar	0.51 <sup>efg</sup>	0.97 <sup>cde</sup>	1.2 <sup>cd</sup>	1.43 <sup>bc</sup>	1.42 <sup>bc</sup>
Poultry biochar	0.18 <sup>g</sup>	1.35 <sup>cd</sup>	2.02 <sup>ab</sup>	2.24 <sup>a</sup>	2.47 <sup>a</sup>
Sawdust biochar	0.3 <sup>fg</sup>	1.14 <sup>cd</sup>	0.42 <sup>efg</sup>	0.45 <sup>efg</sup>	0.47 <sup>efg</sup>
Maize cob biochar	0.23 <sup>g</sup>	1.2 <sup>cd</sup>	0.41 <sup>efg</sup>	0.86 <sup>cdef</sup>	0.76 <sup>defg</sup>

Means with the same letter are not significantly different (p>0.05)



**Table 8: The interaction effect between biochar types and rates on the number of nodules (no plant<sup>-1</sup>) and nodule weight of cowpea (g plant<sup>-1</sup>)**

Biochar types	Biochar rates				
	0 tons ha <sup>-1</sup>	0+ ha <sup>-1</sup>	30kgP	5 tons ha <sup>-1</sup>	10 tons ha <sup>-1</sup>
	<b>Number of nodules( No plant<sup>-1</sup>)</b>				
Swine dung biochar	0 <sup>f</sup>	17 <sup>abc</sup>	15 <sup>bcd</sup>	22 <sup>ab</sup>	26 <sup>a</sup>
Poultry biochar	0 <sup>f</sup>	16 <sup>abcd</sup>	26 <sup>a</sup>	23 <sup>ab</sup>	25 <sup>ab</sup>
Sawdust biochar	4 <sup>ef</sup>	11 <sup>cde</sup>	5 <sup>def</sup>	3 <sup>ef</sup>	7 <sup>cdef</sup>
Maize cob biochar	0 <sup>f</sup>	15 <sup>bcd</sup>	1 <sup>ef</sup>	7 <sup>def</sup>	6 <sup>def</sup>
	<b>Nodule weight (g plant<sup>-1</sup>)</b>				
Swine dung biochar	0 <sup>e</sup>	0.08 <sup>cd</sup>	0.09 <sup>c</sup>	0.1 <sup>bc</sup>	0.1 <sup>d</sup>
Poultry biochar	0 <sup>e</sup>	0.08 <sup>cd</sup>	0.16 <sup>ab</sup>	0.18 <sup>a</sup>	0.25 <sup>a</sup>
Sawdust biochar	0 <sup>e</sup>	0.08 <sup>cd</sup>	0.02 <sup>de</sup>	0 <sup>e</sup>	0.01 <sup>f</sup>
Maize cob biochar	0 <sup>e</sup>	0.05 <sup>cde</sup>	0 <sup>e</sup>	0.02 <sup>e</sup>	0.01 <sup>f</sup>

Means with the same letter in a column within the same treatments are not significantly different (p>0.05)

#### Appendix 1. Some chemical properties of biochar made from different feedstocks

Parameters	Feedstocks			
	Swine dung	Poultry manure	Sawdust	Maize cob
pH (1: 2.5) H <sub>2</sub> O	7.1	9.59	7.38	8.93
pH (1: 2.5) Ca <sub>2</sub> Cl	5.82	9.25	6.62	9.04
Available Phosphorous (mg kg <sup>-1</sup> )	2.01	1.8	0.42	0.84
Total Nitrogen (g kg <sup>-1</sup> )	0.97	0.98	0.07	0.94
Exchangeable bases (cmol kg <sup>-1</sup> )				
Na <sup>+</sup>	1.14	9.6	1.73	1.09
K <sup>+</sup>	19.02	37.7	16.52	28.87
Ca <sup>2+</sup>	3.58	4.1	15.72	3.41
Mg <sup>2+</sup>	16.04	12.63	6.81	12.71

#### REFERENCES

- Agbenin, J. O. (1995). Laboratory manual for Soil and Plant Analysis (Selected Method and Data Analysis). Published by Agbenin. 140pp.
- Alfred, O., Cornelissen, G., Mulder, J. and Dörsch, P. (2015). Effect of soil pH increase by biochar on NO, N<sub>2</sub>O and N<sub>2</sub> Production during denitrification in acid soils. *journal.pone*. 10(9):1-19.
- Bot, A., Benites, J. (2005). The importance of soil organic matter: Key to Drought-Resistant Soil Sustained Food and Production; Food and Agriculture Organisation. UN: Rome, Italy. 5-10pp.
- Egamberdieva, D., Wirth, S. B. U., Abd\_Allah, E. F. and Berg. (2016). Biochar treatment resulted in a combined effect on soybean growth promotion and a shift in plant growth promoting rhizobacteria. *Frontiers Microbiology*. 7: 1-11.
- Etelvino, H. N., Claudi-Maria, B. F. M., Márcia, T. M. and Beáta, E. M. (2015). Biochar: pyrogenic carbon for agricultural use- A critical review. *Rio de Jenerio Brasil*. 39 :321-344.
- Filiberto, M. D. and Gaunt, L. J. (2013). Practicality of biochar additions to enhance soil and crop Productivity. *Agriculture*. 3: 715-725
- Josiah, H., Michael, D. P., Dwight, S. and Andrew, K. (2010). The Basics of biochar: A natural soil amendment. Soil and crop management, SCM-30, UH-CTAHR. College of Tropical Agriculture University of Hawaii, Manoa. 1-6 pp.
- Jyoti, S., Geetika, R. and Mrinal, P. (2013). Impact of addition of biochar along with *Bacillus spp.* on

- growth and yield of French beans. *Scientia Horticulturae*. 162:351–356.
- Lehmann, C.J. and Rondon, M. (2006). Biochar soil management on highly-weathered soils in the tropics. In: Uphoff, N.T. (Ed.), *Biological Approaches to Sustainable Soil Systems*. CRC Press, Boca Raton. 517-530pp.
- Lehmann, J. and Joseph, S. (2009). Biochar for Environmental management: In: Lehmann. J. and Joseph. S (eds). *An introduction in biochar for environmental management*. Earthscan, London, UK. 1- 416pp.
- Muhammad, A., Shah, T., Ilyas, M., Ahmad, W., Mian, A. A., Jadoon, M.A. and Adnan, M. (2015). Effect of organic manures and their levels on weeds density and maize yield. In Pak. J (eds). *Weed Science Research*. 21(4): 517-522pp.
- Nehls, T. (2002). Fertility improvement of a terra firme oxisol in central Amazonia by charcoal applications. MSc thesis, University of Bayreuth, Germany.
- Odesola, I. F., Owoseni, T. and Adetayo. (2010). Small scale biochar production technologies: a review. *Journal of Emerging Trends in Engineering and Applied Sciences (JETEAS)*. 1 (2):150-155.
- Ojanuga, A.G. (2006). Agro-ecological zones of Nigeria Manual. Food and agricultural organisation/NSPFS, Federal ministry of Agriculture. 1-24pp.
- Singh, B., Singh, B.P. and Cowie, A. L. (2010). Characterisation and evaluation of biochars for their application as a soil amendment. *Australian Journal of Soil Research*. 48: 516-525.
- Xu, P., Wu, X., Mu~ noz-Amatriam, M., Wang, B., Wu, X., Hu Y., Huynh, B. L., Close, T. J., Roberts, P.A., Zhou, W., Lu, Z. and Li, G. (2016). Genomic regions, cellular components and gene regulatory basis underlying pod length variations in cowpea (*Vigna unguiculata* L.Walp). *Plant Biotechnology journal*. 10:1-9.

## PREDICTION OF INFILTRATION RATES OF FALLOW AND CULTIVATED SOILS IN MINNA, SOUTHERN GUINEA SAVANNA ZONE OF NIGERIA

Eze, P. C.

Department of Soil Science and Land Management, Federal University of Technology, Minna, Niger State, Nigeria.

\*Corresponding Author's E-mail: peter.eze@futminna.edu.ng; ezepe66@gmail.com; [ezepe66@yahoo.com](mailto:ezepe66@yahoo.com)  
GSM: 08035968227; 07057294915

### ABSTRACT

*A double-ring infiltrometer was used to measure infiltration rates of two soils subjected to two land use management practices in the Southern guinea savanna zone of Nigeria. Results showed that the equilibrium infiltration rate of the tested soils was attained between 1 and 2 hours. Generally, the soils under fallow exhibited higher infiltration rates than those that were cultivated. Curve fitting was done on Kostiakov's, Horton's and Philip's infiltration models. Infiltration data generated using Kostiakov's model were not significantly different from field measured values at 5 % level of probability. This model, therefore, showed a greater accuracy for the soils studied, than the other two models, and is thus recommended for similar soils elsewhere in the Southern guinea savanna zone of Nigeria.*

**KEYWORDS:** Infiltration rates, fallow, cultivated soil, infiltration models.

---

### INTRODUCTION

Measurement of soil water under field condition to ensure sustainable yields in agricultural production is particularly concerned with conserving water from inadequate rainfall in the Nigerian sub-humid, semi-arid and arid zones (Guinea savanna, Sudan savanna and Sahel savanna, respectively), and the application of irrigation water to supplement insufficient rainfall in these savannas. The techniques employed are directed towards increasing the amount of water that goes into the soil from the surface, and to ensure that plants make efficient use of this water. This movement of water downwards into the soil through the surface is termed infiltration. Adequately high rate of infiltration would result in: (i) an increase in the root zone water storage, (ii) reduction in the amount of runoff and flooding and (iii) control of soil erosion. Both water conservation and erosion control involve basically runoff control by enhancing infiltration. Total rainfall in the Nigerian Guinea savanna zone is not as limiting as water distribution within the soil profile, and therefore, the amount or proportion that remains in the root zone for plants to utilize (Payne, *et al.*, 1990).

Infiltration rate decreases with time during an irrigation or rainfall event. The rate of decrease is rapid initially, but in the long-term it approaches a constant value termed equilibrium infiltration rate (Eze *et al.*, 2006). Accumulated infiltration (cumulative infiltration) refers to the total quantity of water that enters the soil in a given time. Infiltration rate and accumulated infiltration are two parameters that are commonly used to evaluate the infiltration characteristics of the soil. The measurement of soil infiltration is essential not only for its importance in irrigation layout and design, but also because it is an important parameter given the best possible estimate in catchment runoff models (IAHS, 1974; Wrigley, 1982). It then entails that realistic planning of water management activities, such as erosion control and irrigation, will require simple information on the rate at which different soils take up water under varying conditions and soil management practices. Eze *et al.* (2006) in a related study noted that some soils in Minna, southern Guinea savanna zone of Nigeria, left fallow for about five years had significantly lower infiltration rates than the cultivated ones. These workers reported that this results so observed was due to the undisturbed condition of the soils under fallow. Data on rates of infiltration of water into soils can be used to supplement other soil information



which could help soil scientists, engineers, hydrologists and others to deal more effectively with a wide spectrum of water resource management and conservation problems.

Measurement of infiltration rate is labour intensive, tedious, cumbersome and it could be quite expensive especially where water supply is limited. Hence, it may be necessary to devise a means of predicting cumulative infiltration and infiltration rate over a given period of time without necessarily carrying out measurements in the field. This can be achieved through the application of certain common time-dependent infiltration models. The theory and process of infiltration have been reviewed by Philip (1969) and Hillel (1971) amongst other soil scientists. A number of infiltration equations and models may be found in the literature mentioned above. These infiltration equations and models may be generally grouped into two broad categories: (i) those which are empirical in nature and/or require fitted parameters, and (ii) those which are derived from the theory of flow in porous media and utilize measured parameters. Equations in the first category have often involved simplified concepts, which permit the infiltration rate or cumulative infiltration volume to be expressed algebraically as a function of time (t) and empirical constants or soil parameters. Some of the equations in the first category mentioned above were used in this study, and they included those by Kostiakov (1932), Horton (1939, 1940) and Philip (1957). It would be necessary to carry out tests on the applicability and accuracy of these infiltration models because some of the available ones may not be applicable under all conditions of soil and climate. The objectives of this research were:

- (i.) To measure the infiltration rates of two selected soils subjected to two types of land use in order to determine the time required for the attainment of equilibrium or steady state infiltration rate.
- (ii.) To predict cumulative infiltration and infiltration rates using three time-dependent infiltration models and determine the one that is most applicable to the tested soils and for use in the management of similar soils.

## METHODOLOGY

The experiment was carried out at two locations, Gidan-kwano and Shintako villages, around Minna in Niger State, Nigeria. Each of the study sites had been under about five years of fallow before the experiment. Minna is located between latitude 6° 00' and 7° 00' North and between longitude 9° 30' and 9° 45' East in the Southern Guinea savannah zone of Nigeria. It has a mean annual rainfall of 1,300mm and a daily temperature range of 27 to 34°C. The Gidan-kwano soil is a sandy loam classified as Plinthustalf, while the Shintako soil is loamy sand classified as Paleustalf (Eze, 2000; Eze *et al.*, 2006).

The experiment consisted of two treatments, namely, fallow and cultivated soils, each replicated four times. Each treatment plot was 2 x 2 m in size. Yellow maize (TZR-Y) was grown on the cultivated plots on the flat. The cultivated plots were tilled manually using a hand-hoe with a blade size of 20 cm cutting width and 30 cm long. The hand-hoe has a total weight of 2 kg. Recommended fertilizer rate was applied using NPK (15:15:15) at 2 and 6 weeks after planting. Manual weeding was carried out on the cultivated plots thrice (at 2, 6 and 12 weeks after planting) with the aid of a smaller hand-hoe.

Infiltration rates were measured on the fallow and cultivated plots with the aid of a double-ring infiltrometer (Ahuja *et al.*, 1976; Eze *et al.*, 2006). The double-ring infiltrometer consists of two rings, inner and outer rings. The inner ring was constructed with a 5 mm thick metal sheet, and was 26 cm in diameter and 34.7 cm in height. The outer ring was made of a 3 mm thick metal sheet, whose diameter and height were 55 and 30 cm, respectively. The two rings were carefully driven 15 cm deep into the ground with minimal soil disturbance in the inner ring. For this purpose, a heavy wooden block was placed on top of the rings upon which moderate blows of a heavy hammer were applied. The heavy wooden block was moved around the edges of the top of the rings after every two to three blows so that the rings could penetrate the soil uniformly, without damage. After the rings were driven into the soil, the disturbed soil adjacent to the rings was made firm by gently tapping the soil with the hand. Four runs each, of infiltration rate measurements were carried out on the fallow and cultivated soils during each measurement interval or period. Infiltration rate measurements were taken before cultivation (0 week after planting), and subsequently at intervals of 4, 8 and 12 weeks after planting.

The process of infiltration was initiated by ponding water in the outer ring. The ponded water was maintained at a shallow depth, to provide a buffer so as to discourage lateral flow and ensure one-dimensional vertical flow. Immediately after applying water into the outer ring, water was applied into the inner ring. The soil surface within the rings was covered with a thin layer of dry grass to prevent direct impact of applied water and a consequent disturbance of surface soil. The fall in water level (in cm) in the inner ring was read at intervals of 1, 2, 5, 10, 15, 20, 30, 45, 60, 75, 90, 100 and 120 minutes as a measure of cumulative infiltration (cm). To achieve this, a metal plate was placed over the outer ring to stabilize a ruler. The ruler was attached to a float in order to keep the ruler standing upright on the surface of the water ponded in the inner ring. Whenever the water level in the inner ring dropped to about 7 cm, more water was supplied to raise the water level to a desired height. Infiltration rate (cm/min) was determined as cumulative infiltration over a specified time (t) period.

The three infiltration models selected to determine degrees of fitness were those of Kostiakov (1932), Horton (1939, 1940) and Philip (1957). They are represented by the following equations:

(i.) Kostiakov's Equation

$$I = Mt^n + b$$

$$i = Mnt^{n-1}$$

(ii.) Horton's Equation

$$I = i_c t + ((i_0 - i_c)/k) [1 - e^{-kt}]$$

$$i = i_c + (i_0 - i_c)e^{-kt}$$

(iii.) Philip's Equation

$$I = St^{1/2} + At$$

$$i = \frac{1}{2}St^{-1/2} + A$$

where, I = cumulative infiltration (cm)

i = infiltration rate (cm hr<sup>-1</sup>)

e = natural logarithm

i<sub>0</sub> = infiltration rate at time t = 0 or initial infiltration rate (cm hr<sup>-1</sup>)

i<sub>c</sub> = final infiltration rate after prolonged wetting or steady state infiltration rate (cm hr<sup>-1</sup>)

t = time (mins) since infiltration started

A, b, M, n, k and S = constants

The soil parameters in each of the infiltration models were obtained after curve fitting using average values (Eze, 2000). Chi-square test was carried out at 0.05 level of significance in order to determine the goodness of fit of the selected infiltration models in relation to the field observed (experimental) infiltration values.

## RESULTS AND DISCUSSION

Data presented in Table 1 indicate that infiltration rates determined in the present study exhibited a common trend of very high initial values, which reduced sharply within the first 15 minutes. Only a slight decrease in the rate of water intake was observed after 45 minutes. Consequently, the rate between 1 and 2 hours is taken as the equilibrium infiltration rate. Soils in Samaru, Zaria, attained equilibrium infiltration rate after 3½ hours (Ahmed, 1982), 4 hours (Adeoye, 1986) and 40 minutes (Kureve, 1991). Okai *et al.* (2000) noted that final infiltration rate of a sandy loam to fine sandy clay loam soil in Kadawa, Kano State, Nigeria could not be attained even after six hours. This observation was attributed to deep penetration of wetting front and decrease in suction potential gradient over a long period of time. The fallow soils generally exhibited higher infiltration rates than those under cultivation (Eze *et al.*, 2006). Cultivation may have destroyed the granular nature of the soils, compacted them and reduced the proportion of macro-pores. Ahmed and Duru (1985) attributed this finding to mainly earthworm activity, penetrating and decaying roots, and continuity of pore channels from the surface down the profile in the soils under fallow.

Curve fitting was done on the infiltration models of Kostiakov (1932), Horton (1939, 1940) and Philip (1957). Table 2 shows the estimated soil parameters for the three model equations. It also displays the Chi-square values of expected infiltration data calculated using soil parameters and field measured (observed) values for cultivated and fallow soils of Gidan-kwano and Shintako sites. Average infiltration rate values obtained using the soil parameters of both Horton and Philip were observed to show a significant difference from experimental results in all cases tested, with the former showing a higher



deviation. The Chi-square values obtained from observed and expected infiltration data were higher than the table value (21.03) at 0.05 level of probability, indicating that there is a significant difference between the field observed infiltration data and the expected values calculated using the soil parameters, A and S in Philip's infiltration model equation, and  $i_0$ ,  $i_c$ , e and k in that of Horton, in all the soils under study (Table 2). In contrast to this finding in the current study, Adindu *et al.* (2015) reported that Philip's infiltration model equation adequately predicted the infiltration rate of some soils in Aba, Abia State, Nigeria.

When field observed infiltration data were compared with the expected values calculated using the soil parameters (b, m and n) in Kostiakov's infiltration model equation, no significant difference was observed. It is evident that Kostiakov's model adequately described the field experimental data. This clearly indicates the superior performance of Kostiakov's model. This finding is similar to those of Ahmed and Duru (1985), Wuddivira (1998) and Adindu *et al.* (2014) who used similar models for related soils. Therefore, Kostiakov's infiltration model can be used to adequately and suitably predict infiltration rates of the soils tested, and similar ones within the Minna environment in particular, and the Nigerian southern Guinea savanna zone in general.

### CONCLUSION AND RECOMMENDATIONS

The purpose of this study was to measure infiltration rate of selected soils under two land use management practices in order to determine the length of time required for the attainment of steady-state (equilibrium) infiltration rate of the selected soils. Another reason was to provide information that would enable farmers and researchers to adequately predict the rate of water entry into the soil without actual measurement in the field. This information will be useful especially in areas where erosion control and irrigation projects are being carried out. This study involved the use of a double-ring infiltrometer to measure infiltration rates of soils subjected to two different land management practices (fallow and cultivated soils) located around Minna in the southern Guinea savanna zone of Nigeria.

The superior performance and accuracy of the Kostiakov's infiltration model is evident from the fact that observation from Chi-square test conducted on infiltration data revealed that the data obtained

using the soil parameters in Philip's and Horton's infiltration models, unlike soil parameters in Kostiakov's infiltration model, were significantly different from the field experimental values. Kostiakov's infiltration model approximated with a higher degree of accuracy to the experimental tests than those of Philip and Horton, and for this reason, the Kostiakov's model is thus recommended for the soils tested and for similar soils elsewhere in the Nigerian Guinea savanna zone. The usefulness of this infiltration model equation can be employed in the design and careful planning of irrigation projects, especially in this zone where short spells of dryness and water shortages result from high rainfall variability. This will ensure the availability of food crops, particularly vegetable crops all year round.

It is noteworthy to mention that this model, like others, is a theoretically derived equation. Therefore, even though it may be found to be significant in soil water management, care must be taken because certain assumptions may be made that may constitute notable deviations from field conditions. The applicability of this model must also be tested for given soil conditions.

### ACKNOWLEDGEMENT

The author gratefully acknowledges the Management of Federal University of Technology, Minna, for funding this study through the provision of research grant.



Table 1: Average infiltration rates (cm hr<sup>-1</sup>) of fallow and cultivated soils at Gidan-kwano and Shintako sites.

Elapsed time (mins)	Gidan-kwano site		Shintako site	
	Fallow	Cultivated	Fallow	Cultivated
1	52.62	32.31	72.43	70.50
2	48.69	26.31	66.86	60.50
5	38.86	19.57	58.37	49.00
10	33.69	15.83	50.91	41.60
15	30.74	14.06	45.94	37.83
20	29.19	12.92	43.37	35.80
30	26.86	11.29	40.44	33.02
45	24.78	10.02	37.41	29.73
60	23.82	9.01	35.56	28.34
75	23.09	8.54	33.90	27.06
90	22.66	8.17	32.98	26.25
100	22.23	7.97	32.16	25.58
120	21.54	7.62	30.59	24.50

Table 2: Estimated soil parameters for infiltration model equations from curve fitting for Gidan-kwano and Shintako sites.

Site	Land use Management	Estimated soil parameters		
		(Kostiakov)	(Horton)	(Philip)
Gidan-kwano	Cultivated soil	M = 0.5343 n = 0.69 b = 0.02 X <sup>2</sup> = 0.06 Ns	i <sub>0</sub> = 24.24 cm hr <sup>-1</sup> i <sub>c</sub> = 6.00 cmhr <sup>-1</sup> e = 2.7182 k = 0.0036 X <sup>2</sup> = 57.40*	A = 5.93 S = 27.83 X <sup>2</sup> = 28.95*
Gidan-kwano	Fallow soil	M = 0.8651 n = 0.81 b = 0.03 X <sup>2</sup> = 0.09 Ns	i <sub>0</sub> = 44.37 cm hr <sup>-1</sup> i <sub>c</sub> = 19.95 cmhr <sup>-1</sup> e = 2.7182 k = 0.0036 X <sup>2</sup> = 54.25*	A = 19.91 S = 36.55 X <sup>2</sup> = 23.92*
Shintako	Cultivated soil	M = 1.1378 n = 0.78 b = 0.07 X <sup>2</sup> = 0.14 Ns	i <sub>0</sub> = 56.71 cm hr <sup>-1</sup> i <sub>c</sub> = 22.50 cmhr <sup>-1</sup> e = 2.7182 k = 0.0036 X <sup>2</sup> = 83.37*	A = 22.46 S = 51.68 X <sup>2</sup> = 37.98*
Shintako	Fallow soil	M = 1.3944 n = 0.79 b = -0.19 X <sup>2</sup> = 0.04 Ns	i <sub>0</sub> = 63.26 cm hr <sup>-1</sup> i <sub>c</sub> = 29.95 cmhr <sup>-1</sup> e = 2.7182 k = 0.0036 X <sup>2</sup> = 67.99*	A = 30.56 S = 47.98 X <sup>2</sup> = 31.02*

M, n, b, A, S, i<sub>0</sub>, i<sub>c</sub>, e and k: Constants under a given soil condition.

X<sup>2</sup>: Chi-square value.

Ns: Not significantly different.

\*: Significantly different at 0.05 level of probability.

Table X<sup>2</sup> value (P = 0.05) = 21.03.

Degree of freedom (n - 1) = 12

## REFERENCES

- Adeoye, K. B. (1986). Physical changes induced by rainfall in the surface layer of an alfisol, northern Nigeria. *Geoderma*, 39: 59 – 66.
- Adindu, R. U., Igbokwe, K. K., Chigbu, T. O. and Ike-Amadi, C. A. (2014). Application of Kostiakov's infiltration model on the soils of Umudike, Abia State, Nigeria. *American Journal of Environmental Engineering*, 4(1): 1 – 6.
- Adindu, R. U., Igbokwe, K. K. and Dike, I. (2015). Philip's model capability to estimate infiltration for soils of Aba, Abia State. *Journal of Earth Sciences and Geotechnical Engineering*, 5(2): 63 - 68.
- Ahmed, A. (1982). Infiltration rates and related soil parameters for some selected Samaru soils. M.Sc. Thesis, A.B.U. Zaria (unpublished), 99 pp.
- Ahmed, A. and Duru, J. O. (1985). Predicting infiltration rates and determining hydrologic grouping of soils near Samaru, Kaduna State, Nigeria. *Samaru Journal of Agricultural Research*, 3(1 & 2): 51 – 60.
- Ahuja, L. R., El-Swaify, S. A. and Rahman, A. (1976). Measuring hydrologic properties of soil with a double-ring infiltrometer and multiple-depth tensiometer. *Soil Science Society of American Journal*, 40(4): 497 – 499.
- Eze, P. C. (2000). Infiltration rates of soils as influenced by land use management in the Nigerian Guinea savanna. M.Tech. Thesis, Federal University of Technology, Minna (unpublished), 21 – 36 pp.
- Eze, P. C., Ezenwa, M. I. S. and Adeoye, K. B. (2006). Effects of some soil physical properties on the infiltration rates of fallow and cultivated soils around Minna, Nigeria. *Journal of Arid Agriculture*, 16: 105 – 111.
- Hillel, D. (1971). *Soil and water: Physical principles and processes*. Academic Press, New York, 74 pp.
- Horton, R. E. (1939). Analysis of runoff plot experiments with varying infiltration capacity. *Trans American Geophysical Union*, Part iv: 693 – 699.
- Horton, R. E. (1940). An approach towards a physical interpretation of infiltration capacity. *Soil Science of America Procedures*, 5: 399 – 417.
- IAHS. (1974). Mathematical models in hydrology. Symposium of Warsaw, July, 1971. IAHS Publication No. 100, IAHS-UNESCO-WMO.
- Kostiakov, A. N. (1932). On the dynamics of the coefficient of water percolation in soil and the necessity for studying it from a dynamic point of view for purposes of amelioration. *Trans 6<sup>th</sup> Committee, International Soil Science Society of Russia*, Part A: 17 – 21.
- Kureve, B. I. (1991). Water intake characteristics of a savanna soil. M.Sc. Thesis, A.B.U., Zaria (unpublished), 72 pp.
- Okai, I. A., Ramalan, A. A. and Adeoye, K. B. (2000). Infiltration characteristics of soils as related to other soil physical properties of a soil sub-group in Kadawa Research Station of Nigeria. *Nigerian Journal of Soil Research*, 1: 8 – 11.
- Payne, W. A., Wendt, C. W. and Lascano, R. J. (1990). Root zone water balance of three low-input millet fields in Niger, West Africa. *Agronomy Journal*, 82: 813 – 819.
- Philip, J. R. (1957). The theory of infiltration for sorptivity and algebraic infiltration equations. *Soil Science*, 84: 257 - 264
- Philip, J. R. (1969). Theory of infiltration. *Advances in Hydroscience*, 5: 215 – 226.
- Wrigley, G. (1982). *Tropical Agriculture*, (4<sup>th</sup> edition). Longman, London. 459 pp.
- Wuddivira, H. N. (1998). Variability of infiltration in a savanna alfisol. M.Sc. Thesis, A.B.U., Zaria (unpublished), 90 pp.



# EFFECT OF METHOD AND RATE OF APPLICATION OF RICE HUSK-RESIDUE ON MAIZE PLANT HEIGHT AND YIELD IN MINNA, NIGERIA.

Eze1\*, P. C., I. N. Onyekwere2, I. A. Balogun1, P. A. Tsado1 and C. E. Azuatalam3

<sup>1</sup> Department of Soil Science and Land Management, Federal University of Technology, Minna, Niger State, Nigeria.

<sup>2</sup> National Root Crops Research Institute, Umudike, Umuahia, Abia State, Nigeria.

<sup>3</sup> Department of Soil Science and Land Management, Federal University of Agriculture, Abeokuta, Ogun State, Nigeria.

\*Corresponding Author's E-mail: peter.eze@futminna.edu.ng; ezepe66@gmail.com; [ezepe66@yahoo.com](mailto:ezepe66@yahoo.com)  
GSM: 08035968227; 07057294915

## ABSTRACT

A 2 x 3 factorial experiment was conducted during the 2014 and 2015 cropping seasons in the Teaching and Research Farm of Federal University of Technology, Minna. The objective of this study was to determine the effect of the method and rate of application of rice husk-residue on maize plant height and yield indices. The treatments consist of two methods of application (surface application and incorporation) and three rates (0, 10 and 15 tons ha<sup>-1</sup>) of application of rice husk-residue, laid out in a randomized complete block design with four replications. Cultural practices were carried out. Plant height was measured at seedling emergence, vegetative growth, tasseling and maturity stages. Yield indices measured were grain yield, stover yield, cob length and cob weight. Results obtained indicated that incorporation of rice husk-residue and application of residue at 15 tons/ha produced the tallest ( $P \leq 0.05$ ) maize plants and longest maize cobs. Method of application of rice husk-residue had no significant effect on grain yield, stover yield and cob weight. Residue incorporation produced longer cobs than surface application. However, 15 tons/ha residue application rate resulted in the highest ( $P \leq 0.05$ ) grain yield and cob length and cob weight. The study suggests that incorporation of rice husk-residue rather than surface application as mulch, and increasing application rate to 15 tons/ha will ensure better maize performance in Minna, Nigeria.

**KEYWORDS:** Rice husk-residue, plant height, maize yield

## INTRODUCTION

Maize is staple food crop that ranks third in the world after rice and wheat (IITA, 2006; Enujike *et al.*, 2013). Also, it ranks third in Northern Nigeria after sorghum and millet, while in both South-east and South-west regions of Nigeria, it is the most important cereal crop followed by rice (FAO, 1996). The basis for this characterization is the extent of land cultivated and the quantity of maize produced per hectare of land. Maize is an energy source in the diets of communities where it serves as staple food, and in livestock feed. It is a major raw material in the production of beverages, corn oil, corn syrup and flakes (Adeyemo and Agele, 2010). However, in most Sub-Saharan African countries, maize yield is as low as 1.3 t/ha, whereas, average yield in advanced countries is about 7 times higher (IITA, 2007). Hussaini and Khan (2002) noted that soil fertility status and management practice are among the factors that affect the productivity of maize.

Inorganic fertilizers are often commonly applied as source of mineral nutrients required to enhance maize growth with a consequent increase in yield (Akinloye and Olaniyan, 2012). However, these mineral fertilizers are beyond the reach of most farmers because they are quite costly (Agyenim-Boateng *et al.*, 2006). Also, increase in soil acidity, nutrient imbalance and poor soil physical condition result from application of inorganic fertilizers over a long period of time (Kang and Juo, 1980). Under these conditions, it may be necessary to employ management practices that would minimize the cost of maintaining soil fertility, enhance crop growth and increase yields.

Crop residues are plant parts such as stalks, stubble, leaves, seed pods and roots left after crop harvest. They are also plant materials such as husk and molasses, which are by products that remain after the harvested crop is processed into a usable form. Crop residues are applied to the soil as organic amendments, rather than being regarded as agricultural waste (McKinney, 2004). They could be

left on the soil surface after harvest or applied as mulch. They could also be burnt or chopped into smaller pieces and incorporated into the soil. Most crop residues unlike rice husk face competition especially as livestock feed and material for construction and fencing (Eze *et al.*, 2014b; Eze *et al.*, 2015b). Rice husk is a milling by-product from rice paddy processing. It is produced in appreciable quantity in rice producing communities in Nigeria and on a global basis. The husk is 80 % organic material, and make up 20 % of rice paddy, with an annual total production of 120 million tonnes worldwide (Giddel and Jivan, 2007). Application of rice husk residue at a rate less than 10 tons/ha has been reported to be insufficient to provide adequate coverage on the soil surface (Chiroma, 2004).

Application of crop residues as organic amendment and a management practice designed to increase soil productivity, improve crop growth and increase crop yields in various agro-ecological zones is well documented (Chiroma *et al.*, 2003 & 2005; Ogbodo, 2004; Eze *et al.*, 2014a and b & 2015b). When crop residues are returned to the soil either as mulch or incorporated into the soil, they have considerable influence on soil properties and crop performance (Ogban *et al.*, 2006; Abbasi *et al.*, 2009). Therefore, the objective of this study was to determine effect of crop residue management practice on the performance of maize.

## METHODOLOGY

A field study was carried out during the 2014 and 2015 cropping seasons at the Teaching and Research Farm of Federal University of Technology, Minna to determine the effect of method and rate of application of rice husk-residue on maize plant height and yield indices. The experimental site is located on latitude 9° 31' N and longitude 6° 26' E. The weather of Minna is characterized by a distinct wet and dry season. It has a mean annual rainfall of about 1,300 mm, usually between April and October. The temperature of the study site is varies from 24 to 33.5°C, particularly between March and June (Ojanuga, 2006). The soils are predominantly sandy in nature and are developed from basement complex. Minna is found in the southern Guinea savanna zone of Nigeria. Its vegetation consists of few trees and shrubs with vast grassland. The common crops grown in the study area are yams, groundnut, cowpea, cereals (sorghum, millet, rice and maize) and vegetables (Amaranthus spp, tomatoes, pepper and okra).

### Treatments and Experimental Design

It was a 2 x 3 factorial experiment consisting of two methods of application (surface application and incorporation) and three rates (0, 10 and 15 tons ha<sup>-1</sup>) of application of rice husk-residue. The treatments were laid out in a randomized complete block design with four replications.

### Agronomic Practices

The land was ploughed using a tractor. The experimental plots were marked out and levelled. Each plot size was 4 x 4 m. Following the application of rice husk-residue, about four seeds of maize (Oba super 1 variety) were sown at a depth of 3 cm and at a spacing of 0.75 x 0.50 m inter-row and intra-row, respectively. The maize seedlings were thinned to two plants per stand at two weeks after planting (WAP). NPK (15:15:15) fertilizer was applied at the recommended rate (90:60:60). Nitrogen was applied in two split doses at two and six WAP. Removal of weeds was done manually using hand-hoe at two and six WAP. At physiological maturity (12 WAP), maize cobs were harvested, sun-dried for about two weeks and threshed.

Plant height was measured at seedling emergence, vegetative growth, tasseling and maturity stages. Plant height was determined using a meter rule, from the base of the plant to the tallest flag leaf. Yield indices measured were grain yield, stover yield, cob length and cob weight. Grains from the net plot were weighed and expressed in kg/ha as grain yield. Stover (above-ground plant parts) yield and cob weight were determined by weighing the stover and cobs, respectively. Cob length was measured using a meter rule.

### Data Analysis

Data collected were subjected to statistical analysis (Analysis of variance, ANOVA) at 0.05 level of probability using Statistix 8.0 software (Statistix, 2010). Duncan's multiple range test was employed for mean separation where significant differences between means were found.

## RESULTS AND DISCUSSION

Results in Table 1 indicated that method of application and rate of application of crop residue had significant effect of plant height at seedling emergence, vegetative growth, tasseling and maturity stages. Incorporation of crop residue resulted in significantly ( $P \leq 0.05$ ) taller maize plants than surface application during all the growth stages. Also, application of 15 tons/ha of rice husk-residue produced the tallest maize plants. These observations were found to be consistent throughout the growing season and in the two-year study period (2014 and



2015). Incorporation of crop residue increased plant height considerably ( $P \leq 0.05$ ) by a range of between 6 and 10 %, while application of residue at 15 tons/ha increased the height of plants by a range of between 10 and 33 %. Kumar and Goh (2000) noted that the benefits that accrue when crop residues are incorporated in the soil include replenishment of soil organic matter, faster mineralization to release essential nutrients for enhancement of crop growth and increase yields.

Method of application of crop residue had no significant influence on grain yield, stover yield and cob weight of maize. However, it significantly affected the length of cobs (Table 2). Incorporation of crop residue as soil organic amendment produced significantly ( $P \leq 0.05$ ) longer cobs compared with surface application of residue, although the better crop growth and longer cobs that resulted from residue incorporation in this study did not translate to significantly higher grain and stover yields. It must be noted however, that incorporation of crop residue has the potential to improve crop yield judging from the fact that this treatment produced significantly taller plants and longer cobs. Results obtained from this work showed that rate of application of crop residue had significant effect on maize yield parameters (Table 2). Application of 15 tons/ha of residue produced highest ( $P \leq 0.05$ ) grain yield, cob length and cob weight compared with 0 and 10 tons/ha application rates. Fifteen tons/ha application rate increased grain yield by over 50 % more than 0 tons/ha and by over 20 % more than 10 tons/ha application rates. It also increased cob length and cob

weight by about 25 and 40 %, respectively. The better performance arising from returning crop residue to the soil is attributed to improvement of soil properties and supply of nutrients through mineralization of the applied crop residues (Abbasi, et al., 2009; Eze *et al.*, 2014a and b & 2015a & b). Thus, crop residues are not agricultural wastes, and should not be regarded as nuisance to the environment because these residues have unlimited potential for improving soil productivity and crop performance, as have been proven in the current study.

## CONCLUSION AND RECOMMENDATIONS

Based on the results obtained in this study, the following conclusions are made:

- i.) Residue incorporation produced tallest plants and longer cobs than surface application.
- ii.) 15 tons/ha residue application rate resulted in the tallest plants, highest grain yield and cob weight, and longest cobs.

Therefore, incorporation of rice husk-residue rather than surface application as mulch, and application of 15 tons/ha of crop residue are recommended for the enhancement of maize performance in Minna, Nigeria.

## ACKNOWLEDGEMENTS

The contributions of the management of Federal University of Technology, Minna and my project students are highly acknowledged.

Table 1: Effect of method and rate of application of rice husk-residue on plant height (cm) of maize.

	Crop growth stages										
	Seedling emergence			Vegetative growth			Tasseling			Maturity	
Treatment	2014	2015	Combined	2014	2015	Combined	2014	2015	Combined	2014	2015
Combined											
Application method (A)											
Surface	41.4a	26.1b	33.7b	113.0b	112.6b	112.8b	182.6b	181.1b	181.8b	176.0a	181.2b
Incorporation	45.4a	29.7a	37.5a	128.3a	124.2a	126.2a	193.2a	193.5a	193.3a	195.8a	
	192.5a	194.2a									
SE±	2.3	1.3	1.4	5.8	5.0	4.1	4.5	5.4	3.4	9.9	4.6
5.4											
Application rate (B)											



0 t/ha	40.6b	20.9b	30.7c	110.6b	77.3b	94.0c	185.9a	153.9b	169.9c	188.8a
157.7b	173.3b									
10 t/ha	40.7b	30.8a	35.7b	117.9b	132.9a	125.4b	185.1a	198.5a	191.8b	186.9a
196.9a	191.9a									
15 t/ha	48.8a	32.0a	40.4a	133.5a	145.0a	139.2a	192.6a	209.6a	201.1a	181.9a
206.0a	194.0a									
SE±	2.8	1.6	1.8	7.1	6.1	5.0	5.6	6.6	4.2	12.1
6.7										5.7
Interaction										
A x B	NS	NS	NS	NS	NS	NS	NS	NS	NS	NS
NS										NS

Means with different letter(s) on the same column are significantly ( $P \leq 0.05$ ) different at 0.05 level of probability  
NS: Not significant

Table 2: Effect of method and rate of application of rice husk-residue on yield parameters of maize.

Treatment	Grain yield (kg/ha)			Stover yield (kg/ha)			Cob length (cm)			Cob	
	weight (g/plot)	2014	2015	Combined	2014	2015	Combined	2014	2015	Combined	2014
2015	Combined										
Application method (A)											
Surface	6,556a	3,776a	5,166a	15,583a	3,677a	9,630a	14.3a	13.7b	14.0a	1,597a	
852a	1,225a										
Incorporation	7,069a	4,355a	5,712a	16,500a	4,229a	10,365a	14.1a	14.7a	14.4a	1,667a	
932a	1,299a										
SE±	614	318	352	1,109	494	671	0.51	0.41	0.33	98	
72	61										
Application rate (B)											
0 t/ha	5,896a	2,626c	4,261b	15,500a	3,328a	9,414a	13.4a	13.0b	13.2b	1,500a	
631b	1,065b										
10 t/ha	7,000a	4,294b	5,647a	15,959a	3,828a	9,893a	14.4a	14.4a	14.4a	1,667a	
980a	1,323a										
15 t/ha	7,542a	5,277a	6,409a	16,667a	4,703a	10,685a	14.8a	15.1a	14.9a	1,729a	
1,065a	1,397a										
SE±	752	390	431	1,358	606	822	0.63	0.5	0.4	119	
88	75										
Interaction											
A x B	NS	NS	NS	NS	NS	NS	NS	NS	NS	NS	
NS	NS									NS	

Means with different letter(s) on the same column are significantly different at 0.05 level of probability  
NS: Not significant

## REFERENCES

- Abbasi, M. K., Mushtaq, A. and Tahir, M. M. (2009). Cumulative effects of white clover residues on the changes in soil properties, nutrient uptake, growth and yield of maize crop in the sub-humid hilly region of Azad Jammu and Kashmir, Pakistan. *African Journal of Biotechnology*, 8(10): 2184-2194.
- Adeyemo, A. J. And Agele, S. O. (2010). Effects of tillage and manure application on soil physicochemical properties and yield of maize grown on a degraded intensively tilled alfisol in Southwestern Nigeria. *Journal of Soil Science and Environmental Management*, 1 (8): 205-216.
- Agyenim-Boateng, S., Zickermann, J. and Kornahrens, M. (2006). Poultry manure effect on growth and yield of maize. *West African Journal of Applied Ecology*, 9: 1-11.
- Akinloye, H. A. and Olaniyan, A. B. (2012). Yield of sweet corn in response to fertilizer sources. *Global Advanced Research Journal of Agricultural Science*, 1(5): 110-116.
- Chiroma, A. M. (2004). *Effects of land configuration and wood-shavings mulch on soil properties, yield and water use of sorghum*. Unpublished Ph.D. Thesis, University of Maiduguri.
- Chiroma, A. M., Alhassan, A. B. and Bababe, B. (2005). Physical properties of a sandy loam soil in north-eastern Nigeria as affected by tillage and stubble management. *Nigerian Journal of Tropical Agriculture*, 6: 115 – 121.
- Chiroma, A. M., Folorunso, O. A. and Kundiri, A. M. (2003). Effects of tillage and stubble management on root growth and water use of millet grown on a sandy loam soil. *Journal of Arid Agriculture*, 15: 83 – 89.
- Enujeke, E. C., Ojeifo, I. M. and Nnaji, G.. (2013). Residual effects of organic manure and inorganic fertilizer on maize grain weight and some soil properties in Asaba area of Delta State. *International Journal of Advanced Biological Research*, 3: 433-442.
- Eze, P. C., Alhassan, A. B., Tsado, P. A., Onyekwere, I. N., Kwari, J. D. and Dada, Y. M. (2014a). Effects of rice bran-mulch on the growth of sorghum and millet in Maiduguri, semi-arid north-east Nigeria. *Nigerian Journal of Soil Science*, 24(1): 59 – 71.
- Eze, P. C., Alhassan, A. B., Kwari, J. D., Dada, Y. M., Tsado, P. A. and Lawan, A. N. (2014b). Yield of sorghum and millet as affected by rice husk-mulch on a sandy loam soil in Maiduguri, semi-arid north-east Nigeria. *Nigerian Journal of Soil Science*, 24(1): 72 – 79.
- Eze, P. C., Alhassan, A. B., Kundiri, A. M., Dada, Y. M., Odofin, A. J. and Tsado, P. A. (2015a). Effects of crop residue-mulch on selected soil physical properties and root zone moisture content under sorghum and millet in Maiduguri, Nigeria. *Production Agriculture and Technology Journal*, 11(1): 12 - 21. [www.patnsukjournal.net](http://www.patnsukjournal.net)
- Eze, P. C., Kwari, J. D., Kundiri, A. M., Tsado, P. A., Onyekwere, I. N. and Dada, Y. M. (2015b). Effects of rice husk-mulch on soil chemical properties under sorghum and millet in Maiduguri, Nigeria. *Production Agriculture and Technology Journal*, 11(1): 22 - 31. [www.patnsukjournal.net](http://www.patnsukjournal.net).
- FAO (Food and Agricultural Organization). (1996). Quarterly Bulletin of statistics. Food and Agricultural Organization, United Nation, Rome, Italy. Pp 8.
- Giddel, M. R. And Jivan, A. P. (2007). Waste to wealth: Potential of rice husk in India, a literature review: International Conference on Cleaner Technologies and Environmental Management, PEC, Pondicherry, India. January, 4 – 6, 2007.
- Hussaini, A. and Khan, S. (2002). Fodder yield and quality of summer cereal fodder crops/hybrid under various regimes of harvesting time. *Journal of Science Technology and Development*, 22: 41-45.
- IITA (2006). Maize overview. International Institute for Tropical Agriculture (IITA). In: Research to nourish Africa, [www.iitaresearch.org](http://www.iitaresearch.org).
- IITA. (2007). Maize. International Institute for Tropical Agriculture (IITA). Retrieved from:

[www.iita.org/cms/details/maize](http://www.iita.org/cms/details/maize)

Projectdetails.aspx?Zoneid=63 and articleid=273-17k.

- Kang, B. T. and Juo, A. S. R. (1980). Management of low-acidity soils in Tropical Africa for food crop production. In: Terry, E. R. (Ed). *Tropical Root Crops: Research strategies for 1980s*, Ottawa, Ontario, 1980.
- Kumar, K. and Goh, K. M. (2000). Crop residues and management practices: Effects on soil quality, soil nitrogen dynamics, crop yield and nitrogen recovery. *Advance Agronomy*, 68: 197 – 319.
- McKinney, R. E. (2004). In: *Environmental Pollution Control Microbiology*. Marcel Dekker, New York. Pp. 447.
- Ogban, P. I., Ogunewe, W. N., Dike, R. I., Ajaelo, A. C., Ikeata, N. I., Achumba, U. E. and Nyong, E. E. (2006). Effect of tillage and mulching practices on soil properties and growth and yield of cowpea (*Vigna unguiculata* (L) Walp) in south-eastern Nigeria. *Proceedings: 31<sup>st</sup> Annual Conference of the Soil Science Society of Nigeria*, Ahmadu Bello University, zaria, November 13 – 17<sup>th</sup>, 2006.
- Ogbodo, E. N. (2004). Effect of tillage methods and crop residue mulch on soil physical conditions, growth and yield of irrigated maize at Abakaliki, Southeastern Nigeria. *Journal of Science of Agriculture, Food Technology and Environment*, 4: 1 – 9.
- Ojanuga, A. G. (2006). *Agro-ecological zones of Nigeria Manual*. FAO/NSPFS, Federal Ministry of Agriculture and Rural Development, Abuja, Nigeria, 124 pp.
- Statistix 8.0. (2010). *Statistix Version 8.0. Statistics for windows analytical software*. Support@statistix.com.



# A REVIEW OF THE CONSTRAINTS OF THE USAGE OF E-AGRICULTURE AND OPPORTUNITIES IN CEREAL CROP FARMING IN AFRICA

By

\*Mshelizah R.J., \*Ajayi, O. J., \*Tsado, J. H., & \* M.Ibrahim

\*School of Agriculture and Agricultural Technology, Department of Agricultural Extension and Rural Development, Federal University of Technology, Minna, Niger State, Nigeria.

Corresponding Authors' email address: [rejoicejames19@gmail.com](mailto:rejoicejames19@gmail.com)

Phone Number: +2348024251665, +2348035170329

## ABSTRACT

Scaling up pilot E-agriculture projects to reach millions of small holder farmers and identifying sustainable business models are still challenging. On the one hand, pricing is critical to sustainable cereal crop business models at the community levels. Investments are needed to cover the cost of creating content and collecting data. On the other hand, social sustainability can be hindered if clear roles and responsibilities have not been clarified among stakeholders. For instance, the location of an E-agriculture Centre should be socially convenient for all users, including women and older people. The primary demand for cereal crops is for food in Africa, especially in the dry land regions where these are the principal crops. This continuing demand is reflected in the trend for increasing area under cereal crop in Africa over the last fifty years, but crop productivity has not kept pace with this increasing demand. This is due to both a lag in crop improvement efforts in these crops and the extreme environmental conditions and the low-input agriculture under which these crops are grown. The presence of strong partnerships with the private sector and community-based seed producers as well as non-governmental organizations (NGOs) has created an excellent opportunity to deploy products adapted to SSA at much higher scale for greater impact at farm levels.

**Key Words: Constraints, E-agriculture, Cereal Crop, Opportunities, Africa.**

## INTRODUCTION

The digital divide is not only concerned with technological infrastructure and connectivity, it is a multi-faceted problem of ineffective knowledge exchanging and management of information content, insufficient human resource and institutional capacity and lack of sensitivity to gender and the diverse needs of different groups for example; illiterates and older farmers often have less developed digital skills and so they are usually less likely to adopt E-agriculture (WSIS, 2014). Scaling up pilot E-agriculture projects to reach millions of small holder's farmers and identifying sustainable business models are still challenging. On the one hand, pricing is critical to sustainable cereal crop business models at the community levels (Bouis *et al.*, 2011). Investments are needed to cover the cost of creating content and collecting data. On the other hand, social sustainability can be hindered if clear roles and responsibilities have not been clarified among stakeholders. For instance, the location of an E-agriculture Centre should be socially convenient for all users, including women and older people (FAO, 2011). This growing demand is increasing the market value of dry land crop residues. Crop

residues (stover) as well as grains are vital feed stocks for cattle, goats and chickens. Sorghum grain is a proven high-quality feed for cattle and poultry, but supplies are not reliable in quantity and quality for the livestock industry to be comfortable in investing in this additional feed resource. Pearl millet grain is also a valuable animal feed, comparable to maize for poultry, but with a higher protein content and a better-balanced amino acid profile, so that less protein concentrate is required in a pearl millet-based feed ration (FAOSTAT, 2015).

### Constraints to the Use of E-agriculture in Cereal Crop Farming

Challenges to the use of E-agriculture are attributed to seven critical factors of success, these include the following:

**Content:** Adaptation of content to local needs, languages and contexts remain challenging. Appropriate information resources, (that is content) and trusted intermediaries are necessary for the success of E-agriculture initiative. Dissemination of information may be constrained if the nature of information does not match farmers need in term of format and relevance. E-agriculture can deliver large amounts of information but does not implies effective use of it (WSIS, 2015).

**Capacity development:** Capacities at individual, organizational and institutional levels need to be strengthened. The focus on improving access to agricultural information without addressing the ability to effectively use the information has not yet yielded the desired reduction of the rural digital divide illiteracy, limited skills in using complex devices to search for information and cultural issues remains barriers to effectively receiving and using information delivered via E-agriculture models of capacity development need to be based on social characteristics, information needed and the function of technology in context (WSIS, 2015). This study by WSIS further revealed that, the price of access to E-agriculture can be very high in some countries. Pricing of broadband or mobile services is an important barrier for most vulnerable group, such as women, youth, older farmers and people living in most remote areas (FAO, 2014).

**Gender and diversity:** Access and opportunities are not distributed equitably among users creating asymmetries that must be addressed with specific policies targeting the source of the inequalities (WSIS, 2014). The study revealed that access for women, youth, older farmers and people living in the most remote areas is hindered by the price of access to E-agriculture for example the broadband or mobile services and by persistent inequalities. Gender inequalities remains a serious issue in the digital economy as does the gap between urban and rural populations (Datir, 2014). The digital divides is not only concerned with technological infrastructure and connectivity, it is a multi-faceted problem of ineffective knowledge exchanging and management of information content, insufficient human resource and institutional capacity and lack sensitivity to gender and the diverse needs of different groups for example; illiterates and older farmers often have less developed digital skills and so they are usually less likely to adopt E-agriculture (Bouis *et al.*, 2011). The study by WSIS, further revealed that many factors that constrained male farmers in adopting more sustainable and productive practices restricts women even more specific gender barrier limit women farmers capacity to innovate and become more productive (FAOSTAT, 2015).

**Access and participation:** WSIS (2015) revealed that access to e-agriculture is not yet equitable. As it was mentioned before a gender based digital persist and is more frequent in the rural than urban areas. The digital divide between men and women is increasing despite the growing number internet users. Improve access to E-agriculture alone will not resolve the gender digital divide. In respect to challenges, proper design and implementation based on a bottom-up and participating approach that involves the communities themselves can reduce the potential for information inequity that can be

created when introducing new technology into a community (AfDB, 2010).

**Partnerships:** Public-private partnership are recognized as a critical factor in sustainable business models at the community level, but these do not always have to be with large corporate firms, small, local private companies, local producer organizations, and community-based NGOs often have the social capital to provide trusted information and good quality services (Datir, 2014). Diverse advisory and extension services offered by different types of providers are more likely to meet the various needs of farmers, as there is no one type of advisory service that can fit all circumstances (FAO, 2011).

**Technologies:** Identifying the right mix of technologies that are suitable to local needs and contexts is often a challenge, in spite of-or because of the rapid increase in mobile telephone penetration in rural areas, while this offers great potential for increasing access to information, there is still challenges in the areas of effective use of mobile telephones that are related to access and capital as described above (Singh *et al.*, 2015). Technologies should be suited to local contents and needs, and their selection should increasingly take into account the influence of E-agriculture have on gender and social dynamics (WSIS, 2014).

**Economic, Social and Environmental Sustainability:** Scaling up pilot E-agriculture projects to reach millions of small holder's farmers and identifying sustainable business models are still challenges. On the one hand, pricing is critical to sustainable agricultural business models at the community levels International telecommunication union (ITU) (2008). Investments are needed to cover the cost of creating content and collecting data. On the other hand, social sustainability can be hindered if clear roles and responsibilities have not been clarified among stakeholders. For instance, the location of an E-agriculture Centre should be socially convenient for all users (including women and older people) (Hassan, 2009).

Measurements and data on the impact of mobile technologies on agriculture are scant and generally anecdotal. Solid information is needed regarding the impact of previous initiatives, including lesson learned, in order to inform the design and approach of future efforts, at the same time, these impacts are inherently difficult to measure because they may not be immediate, or may not be reported or recorded (Datir, 2014). Often, success of E-agriculture interventions in agriculture is on a case-by-case basis. Sustainability of E-agriculture initiatives may be at risk if development organizations' governments and the private sector do not succeed in defining indicators and data that validate investments in



e-agriculture and the positive results these may have (Anne, 2009).

### **Opportunities in maize, sorghum and millet production**

The drylands of Africa provide great opportunities for development and attainment of food security, but only if appropriate crops are grown, the right technologies are used and the appropriate institutions and policies are in place to create a conducive environment. The following factors are considered key drivers which are creating demands for agricultural outputs in the drylands:

- i. Rapid population growth across Africa is raising the demand for locally-grown foods, especially in the dryland regions where sorghum and millets are key cereals crops. Related to this is the fact that, while the majority of poor people are still located in rural areas, an increasing share of the population is migrating to urban areas in search of non-farm jobs. This is raising the demand for foods supplied through commercial markets rather than subsistence production (Balasubramanian *et al.*, 2009).
- ii. In recent years, the demand for sorghum and millets in Africa's crop/livestock systems has risen, creating new opportunities for these crops in the marketplace. As incomes rise across Africa, diets are changing and the demand for livestock products (meat, milk) is increasing. Also associated with growing affluence is an increasing demand in urban markets for value-added products. For example, the demand for finger millet porridge in Kenya far exceeds local supply. Kenyan processors regularly search for finger millet grains in neighbouring Tanzania and Uganda. Finger millet has high levels of iron and fiber and exceptionally high levels of calcium. It also has relatively lower energy content, making it ideal for weaning children, and for pregnant and nursing mothers. Finger millet is also being used in therapeutic feeding programs for diabetics and people who cannot tolerate gluten. This growing demand has stimulated increased investment by agro-processors supplying this and related products to supermarkets and other retail outlets (Ogunwole *et al.*, 2014).
- iv. Another important opportunity for sorghum and millets derives from the persistently high price of

fertilizer in most markets. Thus causing farmers to shift to these crops which can be produced more reliably with limited fertilizer inputs than other cereals. Cash crops like cotton can play an important role in the rotation in these systems in terms of residual Phosphorus (P) and Nitrogen (N) for the legume and cereal crops, respectively. We need to explore how the sorghum/millet systems can leverage the cash crops and their services parts in ensuring the delivery of improved sorghum pearl millet and finger millet technologies to farmers (Balasubramanian *et al.*, 2009).

According to Bouis *et al.* (2011), ICRISAT is currently implementing a number of efforts that seek to utilize these opportunities. Some of these efforts aim at up-scaling improved technology for wider uptake by the farming communities. Examples include:

- The Large-scale diffusion of technologies for sorghum and millet systems. The objectives of the project are (a) to enhance farmers' knowledge of new sorghum and millet production technologies and (b) to facilitate farmers' access to sorghum and pearl millet production technologies in order to strengthen the sorghum and millet value chain. Key partners with ICRISAT in implementing this effort are the Aga Khan Foundation (AKF), the Catholic Relief Services (CRS), farmers' organizations and local NGOs (Nuss and Tanumihardjo, 2011).

- Disseminating learning agenda on resilient-smart technologies to improve the adaptive capacity of smallholder farmers (Adebayo and Kehinde, 2015).

i. Productive stress-tolerant maize varieties and improved crop management practices: Maize can make significant contribution to bridge the gap between food supply and demand in SSA because high yielding, stress tolerant and nutritious maize varieties adapted to the major agro-ecological zones are available for production and delivery to farmers. These products can provide good opportunities for sustainable intensification of production to close the yield gap (Balasubramanian *et al.*, 2009).

ii. Nutritious maize varieties for alleviating protein and micronutrient malnutrition: Maize is considered an ideal vehicle for provitamin-A enhancement and delivery in areas with limited access to supplements and fortified foods (Bouis *et al.*, 2011). In partnership with the HarvestPlus Challenge Program IITA and CIMMYT have made significant progress in developing, testing, and release of provitamin. The production and deployment of nutritious maize cultivars can be expanded to other countries in SSA with similar production environments (Kamara, 2008).



iii. Existence of strong public-private partnerships for product delivery: The presence of strong partnerships with the private sector and community-based seed producers as well as non-governmental organizations (NGOs) has created an excellent opportunity to deploy products adapted to SSA at much higher scale for greater impact at farm level (Balasubramanian *et al.*, 2009).

iv. Availability of new tools for enhancing genetic gains: Continued and intensive application of novel and advanced tools and techniques, including precision phenotyping, doubled haploids (DH), molecular markers, and breeding informatics, are critical for increasing the rates of genetic gain in SSA through accelerated product development (Smale *et al.*, 2011).

v. Increasing demand for maize grain by the poultry feed industry: This will not only create huge demand for maize grain, but also enhanced use of provitamin A enriched maize as natural agent that imparts an attractive yellow color to poultry meat and eggs. Making aflatoxin-safe maize available also is crucial since the toxin kills birds, stunts growth and induces other harmful effects (Alene, 2009).

vi. Dual-purpose maize: The decline in farms size has seen livestock being edged out of the farm and the decline in the number of livestock units on the farm. The model of land set aside for crops and a different one for livestock feed only means more competition between food and feed. Dual-purpose maize can mitigate this as it ensures co-existence of crops and livestock on the farm (Grings *et al.*, 2013). The development and availability of such maize varieties can promote diverse utilization of maize, increase income generating opportunities for farmers and processors, reduce the labor requirement of women at household level, and contribute to reduction of waste (Prasanna and Mahuku, 2015).

vii. Developing better Aflasafe products, aflatoxin management systems and delivery mechanisms: Until now, registered and registration-ready country-specific products are available in a handful of countries. More products are required for use in countries currently not having any (AfDB, 2010). There is a need to develop regional products that can be used in several countries thereby expanding the market of such products to attract more private sector investment in technology dissemination and scale-up. Aflatoxin management requires an integrated approach and systems and mechanisms for its delivery needs to be developed and implemented. Also required are aflsafe manufacturing plants in five countries to make the products available in the region (Smale *et al.*, 2011).

Sub-Saharan Africa has a tremendous scope and potential for increasing bread and durum (pasta) wheat productivity, whilst likely worst affected by climate change for example shortened growing seasons, erratic rainfall, increases in both day & night temperatures, new emerging diseases. Some of the highest spring wheat yields worldwide are obtained in African countries (Egypt, Ethiopia, Namibia, Zambia, Zimbabwe), but only by very few farmers (Ogunwole *et al.*, 2014). Modelling-based yield estimates in a CIMMYT/IFPRI Study in SSA, for rainfed and irrigated wheat farming systems identified countries with potential for wheat production. The results of the IFPRI-CIMMYT simulation analysis provide strong evidence for the economic profitability and competitiveness of domestic wheat production for the selected SSA in African countries. These preliminary results based on large grid data require follow up on detailed regional / local analysis (FAO, 2011).

**Opportunities in wheat and rice production include the following:**

i. Small and big farmers in specific African countries and agro-ecologies could produce more high quality wheat more profitably and sustainably. This becomes a source of stable cash-crop next to other farm (diversification) and non-farm income, if value chains function better (Prasanna and Mahuku, 2015).

ii. Very fast growing consumer demand offers great potential for generating value addition, larger and more diverse wheat-based markets and more inter-regional trade (wheat and finished wheat products) (Grings *et al.*, 2013).

iii. Change national and regional policies to incentivize effective flow of agricultural research to farmers, to develop a wheat seed sector that promotes faster access to high quality seed and value addition along the wheat value chain in-country/region (Tahirou, 2009 and Fisher *et al.*, 2015).

iv. Expand current projects activities (for example, Durable Rust Resistant Wheat, funded by BMGF/DFID; SARD-SC/AfDB; Ethiopian Wheat/USAID and others) focusing on breeding resistant varieties and providing seed to farmers. Through a greatly expanded effort, most rust susceptible wheat varieties should be replaced in East and Central Africa (FAO, 2011). This would greatly reduce the rust inoculum and thereby the chances that new races emerge from mutations and also make a great contribution to regional and global food security, since these virulent races can and have travelled to other global bread baskets in N-Africa, Asia, Europe and Australia (Tahirou, 2009 and Fisher *et al.*, 2015).

v. Increase farm power through appropriate-scale mechanization, so farmers can deal with labor shortage, livestock-related trade-offs, drudgery for women farmers (Baudron, 2015).

vi. Improved wheat varieties with high yield, heat and drought tolerance, pest and disease resistance, adequate nutrition and processing characteristics, nitrogen use efficiency and in some regions acid soil tolerance (Prasanna and Mahuku, 2015).

vii. Replace yellow and stem rust susceptible varieties to reduce risk of epidemics and at same time reduce probability that new races emerge through reduced inoculum (Tahirou, 2009 and Fisher *et al.*, 2015).

viii. Seed system innovations (get the right seed to farmers faster) (Ogunwole *et al.*, 2014).

ix. For all of the above, enhance sustainable scaling-up of technologies and innovations along the value chains through innovative platforms, exemplified by the SARD-SC project with continental coverage. They promote effective technology transfer by involving all stakeholders (Baudron 2015).

x. Enable development of more efficient markets at national and regional levels. Consumer demand is there and predicted to grow even faster (Mason, 2012).

xi. Develop effective wheat value chain system, based on multi-stakeholder constraints and opportunities analyses (Prasanna and Mahuku, 2015).

xii. There is a great potential for accelerating agricultural productivity to achieve the green revolution that Africa urgently needs. Africa has sufficient land and water resources to produce enough rice to feed its teeming population (Balasubramanian *et al.*, 2009).

xiii. The potential irrigable land in West Africa alone, estimated at about 8.9 million hectares of which less than 10% (920,000 hectares), is mostly utilized for rice and other crops. Irrigated rice production systems are considered the most promising because the highest rice yields per hectare are obtained under irrigation and in addition it offers the chance of two to three crops per year. The potential for expanding irrigation is large especially as we look beyond erratic rainfall in rain-fed ecologies (Ogunwole *et al.*, 2014).

Xiiii. Apart from Africa's natural resource endowment, its youthful population is regarded as a major human resource that will drive economic growth in the next decade. The prospects for youth engagement in agricultural development in Africa are enormous. Africa Rice and its partners have adopted the rice sector development hubs that represent key rice growing environments and market opportunities across African

countries (Child, 2015). The rice hubs are made to work for resource poor smallholder using multi-stakeholder innovation platforms (IPs). The IPs in the hubs are linked to major national and regional rice development efforts to facilitate broader uptake of rice knowledge and technologies (Baudron 2015).

## Conclusion

Measurements and data on the impact of mobile technologies on agriculture are scant and generally anecdotal. Solid information is needed regarding the impact of previous initiatives, including lesson learned, in order to inform the design and approach of future efforts, at the same time, these impacts are inherently difficult to measure because they may not be immediate, or may not be reported or recorded. Often, success of e-agriculture interventions in cereal crop farming is on a case-by-case basis. Sustainability of e-agriculture initiatives may be at risk if development organizations' governments and the private sector do not succeed in defining indicators and data that validate investments in e-agriculture. The Bill and Melinda Gates Foundation-funded Second phase of the HOPE for sorghum and Millets Project, expected to commence in January 2016, will emphasize on technology outreach and uptake as the key thrust, even as it maintains technology development efforts through breeding of improved cultivars and determination of better crop management options. The project will work to strengthen the seed systems by working with the national seed institutions (public and private) to streamline and enhance seed production and timely delivery to farm households. Public and private national partners will continue to be the main implementers of project activities. The research and technology development agenda will be led by the national agricultural research institutions in each implementing country. Local and International NGOs, and seed enterprises in each country have been mobilized to play critical roles.

## References

- Adebayo, O., & Kehinde, O. (2015). Impact of Agricultural innovation on Improved Livelihoods and Productivity among Small Farmers in Rural Nigeria. A working Paper 2015/07, Maastricht school of Management.
- African Development Bank (AfDB) (2010). <http://afdb.org> Director General of Africa Rice, Co-conveners: Tabo Ramadijita. Retrieved 23<sup>rd</sup> September 2011.
- Alene, A. D. (2009). The Economic and Poverty Impact of Maize Research in West and Central



- Africa. *Agricultural Economics*, 40: 535-550.
- Anne, R. (2009). Livelihood Strategies in a globalizing World. Analysis of Farmers' Strategies in Southern Mali with Emphasis on Milk Production. Published M.Sc. Thesis Rural Sociology and Plant Production Systems.
- Balasubramanian, V., Sie, M., Hijmans, R., & Otsuka, K. (2009). Increasing Rice Production in Sub-Sahara Africa: Challenges and Opportunities. *Advances in agronomy*, 94, 55-133.
- Baudron, E. (2015). Re-examining Appropriate Mechanization in Eastern and Southern Africa: Two- wheel Tractors, Conservation agriculture, and Private Sector Involvement, *International Journal of Agriculture and Food Security*, 2(11), 37-40.
- Bouis, H. E., Hotz, C., McClafferty, B., Meenakshi, J. V., & Pfeiffer, W. H. (2011). Biofortification: a new tool to reduce Micronutrient Malnutrition. *Food Nutr. Bulletin*. (32), 31-40.
- Childs, N. (2015). Rice Outlook. <http://www.ers.usda.gov/media/1902020/res-151-final.pdf> Retrieved 10<sup>th</sup>/07/2015.
- Datir, S., & Wagh, S. (2014). Monitoring and Detection of Agriculture Disease using WSN, *Intentional Journal of Agriculture and Crop Disease Control*. 87, 58-67.
- Fisher, M. (2015). Drought Tolerant Maize for Farmers adaptation to drought in Sub-Saharan Africa: Determinants of adoption in Eastern and Southern Africa. *African Journal of Agriculture, "Climate change"* 2(10), 1007-1058.
- Food and Agricultural Organization (FAO) (2011). The state of Food and Agriculture. Women in Agriculture. Closing the Gender gap for Development. 4(12), 56-65.
- Food Agricultural Organization (FAO). (2011). The State Food and Agriculture. Women in Agriculture. Closing the Gender gap for Development. *International Journal of Agriculture*. 3(10), 87-90.
- Food and Agricultural Organization Statistics (FAOSTAT) (2015). <http://faostat.fao.org>. Retrieved October 6, 2015. ICRISAT (21-23 Oct. 2015). An action plan for African Agricultural Transformation.
- Food and Agriculture Organization of the United Nations (FAO). (2014). E-agriculture a definition and profile of its application. <http://www.fao.org/rdd/doc/e-agriculture-10-051.pdf>. Retrieved 22<sup>nd</sup> October, 2015.
- Grings, E., Erenstein, O., & Blummel, M. (2013). Special Issue: Dual- Purpose Maize. *Field Crops Research* (153)1-12.
- Hassan, A. D. (2009). Nigeria: E-Agric - Farming through internet- AllAfrica.com. Retrieved 18<sup>th</sup>, September, 2009.
- International Telecommunications Union (ITU) (2008). Food and Agricultural Organization E-Agriculture Report Draft. Commission on Science and Technology for Development. Retrieved 30<sup>th</sup> may, 2008.
- Kamara, A. Y. (2008). A Participatory Approach to increasing Productivity of Maize through *Striga hermonthica* control in Northeast Nigeria. *Experimental Agriculture*. 44(3), 349-364.
- Mason, R. (2012). Wheat Consumption in Sub-Sahara Africa: Trends, Drivers, and Policy Implications, MSU International Development Working Paper 127, December.
- Nuss, E.T., & Tanumihardjo, S. A. (2011). Quality Protein Maize for Africa: Closing the protein inadequacy gap in vulnerable populations. *Adv. Nutrition*. OECD/FAO Organization of the United Nations (OECD) Publishing, Paris. (2), 217-224.
- Ogunwole, J. O. Bello, A.L., & Owonubi, A.T. (2014). Environmental Characterization of Cereal Producing Areas of Nigeria. *International Journal of Agricultural Research*. 4 (12), 98-112.



- Prasanna, B.&Mahuku, G. (2015). Maize Lethal Necrosis (MLN) in eastern Africa: tackling a major Challenge. *The Africa Seed* (March 2015 Issue), 18-21.
- Singh, K. Kumar, A. & Singh, R. (2015). Role of Information and Communication Technologies in Indian Agriculture: An Overview. *SSRN Electronic Journal*. 3(9), 103-109.
- Smale, M. Byerlee, D. & Jayne, T. (2011). Maize Revolution in sub-Saharan Africa. Policy Research working paper. Washington DC: World Bank. 56-59.
- Tahirou, A. (2009). Assessing the constraints affecting production and development of maize seed in DTMA Countries of West Africa. IITA, Ibadan, Nigeria, 40
- World Summit Information Society (WSIS) (2014). Third World Summit Information Society (WSIS) MPP Meeting held on 17 – 18 February 2014.  
[www.itu.int/wsiv/review/reports#actionline](http://www.itu.int/wsiv/review/reports#actionline)  
Retrieved 7<sup>th</sup> March, 2014.
- World Summit Information Society (WSIS) (2015). 10 Years WSIS Action Line Facilitator's Reports on the Implementation of WSIS outcomes. WSIS Action Line- C7: E-Agriculture. Lead

# A REVIEW OF THE CHALLENGES INVOLVED IN CEREAL CROP FARMING AND SUGGESTED ACTIONS ON THE WAY FORWARD IN CEREAL CROP FARMING IN AFRICA

By

\*Mshelizah R.J., \*Ajayi, O. J., \*Tsado, J. H., & \* M.Ibrahim

\*School of Agriculture and Agricultural Technology, Department of Agricultural Extension and Rural Development, Federal University of Technology, Minna, Niger State, Nigeria.

Corresponding Authors' email address: [rejoicejames19@gmail.com](mailto:rejoicejames19@gmail.com)

Phone Number: +2348024251665, +2348035170329

## ABSTRACT

Africa is the Centre of origin and also a major producer of several cereal like sorghum, pearl millet, finger millet, teff and African rice. Another major cereal is maize, has over taken these traditional cereals, while wheat is widely cultivated in the northern Africa and in Sudan and Ethiopia. Cereals like Sorghum, Millets, Wheat, Maize and Rice are the major staple foods of the most populations. The cereals are grown over an acre of 98.6m ha producing 162m tons. The main crops currently cultivated in the African countries are the cereals such as millet, sorghum and maize. The African rice sector has the potential to become an engine for economic growth across the continent, contributing to eliminating extreme poverty and food insecurity. All in all, realizing the full potential of wheat for food security in Africa requires developing suitable and target oriented varieties and technological packages. The recently released multiple stress tolerant, nutrient-use efficient and nutritious maize varieties will be targeted for production, promotion and delivery to enhance adoption by maize farmers for sustainable intensification. The natural soil fertility in this areas is low. To restore and maintain soil fertility farmers used to rely on long fallows (> 10 years) in their crop rotation. For several decades, the use of fallow to maintain soil fertility is no longer feasible. Therefore livestock's contribution to soil organic matter has become indispensable in the cereal crop farming system.

**Key Words: Challenges, Cereal Crop, Way Forward, Africa.**

## INTRODUCTION

Africa with its vast land area covering 3 billion ha has 1.3 billion ha of agricultural land out of which only 252 million ha (19.36%) is for arable crops (FAO, 2011). Africa is the Centre of origin and also a major producer of several cereal like sorghum, pearl millet, finger millet, teff and African rice. Another major cereal is maize, has over taken these traditional cereals, while wheat is widely cultivated in the northern Africa

and in Sudan and Ethiopia. Agriculture is the engine for growth in Africa with subsistence agriculture practiced by the majority of the small holder farmers, yields gaps are high and poor soils, amongst other constraints add to the difficulties for sustainable farming and incomes. Cereals like Sorghum, Millets, Wheat, Maize and Rice are the major staple foods of the most populations. The cereals are grown over an acre of 98.6m ha producing 162m tons (FAOSTAT, 2012).

Table 1: Area and production of selected cereal crops in africa

Crops	Africa	
	Area (ha)	Production
Maize	34,075,972	70,076,591
Millet	19,998,008	16,008,838
Rice paddy	11,206,813	28,798,202
Sorghum	23,142,595	23,350,064
Wheat	10,224,952	24,704,201
Total	98,226,080	162,422,507

Source: FAOSTAT, 2015

## **A Review of some Selected Cereal Crops, Challenges involved and a way Forward in Africa**

### **Maize**

Maize is the most widely-grown staple food crop in sub-Saharan Africa (SSA) occupying more than 33 million ha each year. The crop covers nearly 17% of the estimated 200 million ha cultivated land in SSA, and is produced in diverse production environments and consumed by people with varying food preferences and socio-economic backgrounds (IITA, 2008). More than 300 million people in SSA depend on maize as source of food and livelihood. The top 20 countries, namely South Africa, Nigeria, Ethiopia, Tanzania, Malawi, Kenya, Zambia, Uganda, Ghana, Mozambique, Cameroon, Mali, Burkina Faso, Benin, DRC, Angola, Zimbabwe, Togo, and Cote d'Ivoire, account for 96% of the total maize production in SSA (FAOSTAT, 2015).

The planted land of maize and grain production have increased significantly across regions in SSA since 1961. Of the 22 countries in the world where maize forms the highest percentage of calorie intake in the national diet, 16 are in Africa. Maize accounts for almost half of the calories and protein consumed in ESA, and one-fifth of the calories and protein consumed in West Africa. Regional average yields are as high as 1.7 t/ha in West Africa and 1.5 t/ha in East Africa, and 1.1 t/ha in Southern Africa (IITA, 2008). Even though some countries (for example, Ethiopia with >3 t/ha) have made significant productivity gains, the average yield of maize in SSA (estimated at <1.8 t/ha) is still far below the global average yield of maize (~5 t/ha) and considerably below the 4.4-5.4 t/ha on-farm trial results of improved varieties under optimal inputs and improved management conditions undertaken by IITA within SSA (Nuss and Tanumihardjo, 2011). Partners working under IMAS project have released 11 nitrogen use efficient (NUE) maize hybrids, and produced 2,300 MT of seed in 2014 (Smale *et al.*, 2011). Many DT and NUE varieties are being scaled-up in eastern, southern and West African countries, with significant present and potential impacts (Alene, 2009 and Kostandiniet *al.* (2015). Similarly, under the Integrated Striga Management for Africa (ISMA) project, IITA, CIMMYT and partners in Kenya and Nigeria came together to develop and deploy Striga-tolerant improved maize varieties. Some of the projects have also developed improved crop management practices, including cereal-legume rotation to control Striga and to improve soil fertility (Kamara, 2008). Maize is a major staple food crop grown in diverse agro-ecological zones and farming

systems, and consumed by people with varying food preferences and socio-economic backgrounds in sub-Saharan Africa (SSA). The central role of maize as a staple food in SSA is comparable to that of rice or wheat in Asia, with consumption rates being the highest in eastern and southern Africa (ESA). Considering the low average maize grain yields that are still pervasive in farmers' fields, meeting the projected increase demand for maize grain in Africa presents a challenge (FAOSTAT, 2015).

### **Challenges involved in Maize Farming**

i. *Difficulty in meeting the projected maize demand with the current low on farm yields and high postharvest losses:* Considering the projected increase in annual maize demand in Africa reaching 52 million tons by 2020, the current increase in yield gains averaging only 1% presents a challenge for countries to meet this demand (Bouisset *et al.*, 2011). Yield gaps are pervasive in African smallholder farmers' fields, and are large for maize and other crops in all regions. If actions are not taken to close these yield gaps, smallholder farmers will not be able to benefit from the current yield gains offered by genetic improvement of maize (Mahuku, 2005). Similarly, inappropriate postharvest handling of grain leads to an estimated 20% avoidable losses in the postharvest stages. Saving half of this loss will make more efficient use of resources used for growing crops and add 10% more maize in African economy (IFPRI, 2000).

ii. *Impact of climate change and persistent biotic and abiotic stresses:* In addition to the high incidence of diseases, insect-pests, and parasitic plants, drought, high temperatures, and sub-optimal soil nitrogen have also presented a continuous challenge to maize productivity in SSA. Besides drought and poor soil fertility, biotic stresses such as Maize lethal necrosis (MLN), Maize Streak Virus (MSV), Turicum Leaf blight (TLB), Gray leaf spot (GLS), southern leaf rust, blight, stalk borers, and the parasitic weed *Striga hermonthica* (Bouisset *et al.*, 2011). Similarly, maize is particularly prone to contamination with aflatoxin which is a serious impediment to improving health of African people and generating higher income (Gringset *et al.*, 2013).

iii. *Maize lethal necrosis (MLN) is threatening food security in eastern Africa:* Since 2011, MLN has emerged as a major threat to food security in the region. Kenya's loss was estimated at 0.3 million tons per year, or 23% of the average annual production estimated at US\$ 110 million (US\$ 365/ton) (Adejuwon, 2013). The situation is particularly



critical as more than 95 per cent of the commercial maize varieties in eastern African seed market are vulnerable to MLN. This means that Kenya and neighboring countries (D.R. Congo, Ethiopia, Rwanda, Tanzania and Uganda) where the disease has been reported are on the verge of serious food insecurity, unless urgent and intensive actions are taken (Prasanna and Mahuku, 2015).

iv. *Barriers to adoption of improved maize varieties:* There are several major factors impeding adoption of improved climate-resilient maize varieties; these include: limited capacity of seed companies hampering product delivery at scale (especially in West and Central Africa), lack of adequate availability of improved seed, lack of awareness, unavailability of credit, and unaffordable seed price. The impact of these factors varied from country to country indicating that dissemination strategies will need to be further tailored (Tahirou, 2009 and Fisher, 2015).

v. *Lack of adequate integration of improved genetics with sustainable intensification practices in maize-based cropping systems:* Improved agronomic practices, soil fertility, water management and weed control, and enabling policies are key determinants of crop productivity. Maize yields need to be significantly boosted by scaling-up and scaling-out custom-made conservation agriculture practices (Adejuwon, 2013).

vi. *Insufficient investment on enhancing genetic gains, improved agronomy and other technologies:* Some countries in SSA (for example, Burkina Faso, Cameroon, Cote d'Ivoire, D.R. Congo, Togo, Senegal among others) have faced serious challenges in developing, testing, release and deployment of new maize varieties and improved agronomic interventions due to insufficient R4D investment (FAOSTAT, 2014). Support is needed to scale-up and deliver improved multiple stress tolerant, nutrient-use efficient and nutritious maize varieties, curb the spread and impact of maize lethal necrosis (MLN), strengthen the maize breeding pipeline for enhancing capacity of national agricultural research and extension service (NARES) and small and medium enterprises seed (SMEs) companies, sustainable intensification of maize-based agri-food systems, and develop better Aflasafe products, aflatoxin management systems and delivery mechanisms (Mahuku, 2005).

### **The way forward in maize production**

i. Scaling-up and delivering improved multiple stress tolerant, nutrient-use efficient and nutritious maize varieties: The recently released multiple stress tolerant, nutrient-use efficient and nutritious maize varieties will be targeted for production, promotion and delivery to

enhance adoption by maize farmers for sustainable intensification (Kostandini, 2015). International Institute for Tropical Agriculture (IITA) and International Maize and Wheat Improvement Center (CIMMYT), together with local knowledge and skills of a broad range of National Agriculture Research and Extension Service (NARES), private sector, and community-based seed producers in SSA will be harnessed to catalyze improved seed production, widespread promotion and delivery of the maize varieties and hybrids (Fisher, 2015).

ii. Curbing the spread and impact of MLN is a complex challenge and has to be effectively addressed as an immediate priority through several simultaneously-implemented strategies, including development and deployment of MLN tolerant/resistant germplasm, agronomic mitigation practices, crop rotations (especially with legumes), and preventing further spread of MLN-causing viruses through contaminated seed from the endemic to the non-endemic areas in Africa. This requires strong support from the policy makers and the Governments, coordinated and synergistic efforts of various institutions engaged in maize, and greater commitment from all the players involved in the maize value chains in Africa (Prasanna, 2015).

iii. A stronger maize breeding pipeline for enhancing capacity of NARES and SMEs in SSA with improved climate-resilient varieties, and genetic gains in the farmers' fields: Intensive efforts are required to increase genetic gains in terms of maize yields in the farmers' fields from the present rate of <1% to at least 2% in the next 6-7 years. This will require enhanced adoption of modern tools and techniques for reducing product development time, but also rapid replacement of several 15 plus year-old, obsolete, climate-vulnerable maize varieties that are still grown in several countries in SSA. In addition, it is important to enhance capacity of NARES and Small and Medium-Sized Enterprises (SMEs) seed companies in SSA to test, release, demonstrate and deliver improved stress resilient and nutritious maize varieties/hybrids to the smallholders (FAOSTAT, 2015).

iv. Developing and deploying maize with enhanced nutritional and end-use quality traits: This activity will develop and deploy nutritious maize with high provitamin A, zinc, and essential amino acids, to attain greater impact on the nutritional status of the poor, especially pregnant women, nursing mothers and pre-school children. Also, a program to develop and deploy dual-purpose maize varieties will be launched, so that the farmers can harvest significant grain yield but also equally significant yield of quality Stover to feed the livestock (Gringset *et al.*, 2013).

v. Sustainable intensification of maize-based agri-food systems through climate-smart crop management practices and decision support tools: CIMMYT and IITA have developed and validated climate-smart agricultural (CSA) practices for sustainable intensification of maize-based systems in SSA. These improved crop management practices will be widely promoted. In addition, investment in developing and using decision support tools for deployment of technologies to appropriate target zones and in maize agronomy research will contribute to closing the maize yield gap at farm level (Kostandini, 2015).

vi. Developing better Aflasafe products, aflatoxin management systems and delivery mechanisms: Aflatoxin management system will integrate aflasafe, pre and postharvest management, awareness, training, market linkages, creation of testing facilities, advocacy and enhancing regulatory capacity (FAO, 2005).

vii. Capacity development and building a new generation of maize professionals in SSA: Strengthening the capacity of both research and development partners will be critical for further knowledge transfer, shared learning, innovations and sustainable impacts. In addition to research collaboration and technical backstopping, targeted capacity building activities will include post-graduate training, organization of both short- and long-term visiting scientist fellowships, refresher training workshops from public and private sectors (Fisher *et al.*, 2015).

### **Sorghum and Millets**

Sorghum is the second most important cereal after maize with 22% of total cereal area, followed by millets (pearl and finger) with 19% of the total cereal land coverage. The continuing demand for these two crops is reflected in the trend for increasing area under sorghum and millets in Africa over the last fifty years (FAOSTAT, 2015). Unfortunately however, crop productivity has not kept pace with increasing demand, due mainly to a lag in crop improvement efforts in sorghum and millets, relative to other cereals, and the extreme environmental conditions and resource constrained, low-input farming systems where these crops are grown. Furthermore, in such dry land environments, the issues of climate variability, change and land degradation are acute with a lack of progress the result of neglect, remoteness and weak national institutions. Despite these factors there is a strong case for stepping up the efforts towards development of technologies (germplasm improvement, agronomic management), markets and institutions to advance the case for sorghum and millets in the dryland tropics of Africa (Idem and Showemimo, 2011).

According to Adejuwon (2013) cereals like Sorghum, Millets, Wheat, Maize and Rice are major staple foods of the most population. These cereals are grown over an area of 98.6 m ha producing 162 m tons. Sorghum is the second most important cereal after maize with 22% of total cereal area. Pearl millet is a climate hardy crop which is grown in harsh conditions, but as a subsistence crop. Increasing productivity of the small holder farmers, bridging the yield gaps by providing appropriate inputs along with improved technologies such as stress resistant and high yielding varieties and empowering farmers to better manage climate risk will be a huge step towards agricultural transformation (Gringset *et al.*, 2013).

The primary demand for sorghum and millets is for food in Africa, especially in the dry land regions where these are the principal crops. This continuing demand is reflected in the trend for increasing area under sorghum and millets in Africa over the last fifty years but crop productivity has not kept pace with this increasing demand (Klapwijk *et al.*, 2014). This is due to both a lag in crop improvement efforts in these crops and the extreme environmental conditions and the low-input agriculture under which these crops are grown. Thus it is immediately evident that crop improvement efforts combined with improved agronomic practices is a must for these crops, especially in view of the reducing arability of land (Kostandini, 2015). Interventions of the Bill and Melinda Gates Foundation-supported HOPE project (Harnessing Opportunities for Productivity Enhancements) for sorghum and millets that started in 2009, have demonstrated that yield gains from as low as 17 to as high as 141 per cent for these crops are possible through the use of improved varieties and associated improved agronomic practices. The International Crops Research Institute for the Semi-Arid Tropics (ICRISAT) has the mandate for research and development of sorghum, pearl millet and finger millet, among other crops (FAO, 2011). A number of initiatives are currently ongoing that present good opportunity for the current process to tap from. Some of the key ongoing initiatives are:

i. Harnessing Opportunities for Productivity Enhancement (HOPE) of sorghum and millets in Sub-Saharan Africa Project, supported by the Bill and Melinda Gates Foundation, and implemented by ICRISAT in partnership with the national partners in 10 African countries. Phase 1 of this project (July 2009 to June 2015) covered Burkina Faso, Mali, Niger and Nigeria (in WCA) and Ethiopia, Eritrea, Kenya, South Sudan, Tanzania and Uganda in ESA. Phase 2 of the HOPE project, which is expected to commence in January 2016 and run for five years, will involve



Burkina Faso, Mali and Nigeria (in WCA) and Ethiopia, Tanzania and Uganda (in ESA)(Adejuwon, 2013).

ii. Enhancing the adoption of improved sorghum varieties for increased agricultural system productivity and food security in Nigeria, Supported by West Africa Agricultural Productivity Program (WAAPP) (FAO-UN, 2015).

iii. Agricultural Transformation Agenda Support Project Phase-1 (ATASP-1) outreach sorghum component supported by the African Development Bank through the Nigeria Federal Ministry of Agriculture (FAO, 2011).

iv. Sorghum Transformation Value Chain (STVC) supported by Nigeria Federal Ministry of Agriculture and Rural Development and United States Agency for International Development (USAID) funded Africa Rising project on large scale sustainable intensification in 5 countries of ESA and WCA including the dissemination of technologies for sorghum and millet based farming systems in Mali (Ismaila *et al.*, 2010).

These initiatives have led to significant achievements with the release of high yielding improved sorghum and millet varieties adaptable across the target countries and agro-ecologies. The ATASP-1 outreach program that is implemented by IITA, ICRISAT and AfricaRice in partnership with several NAREs and private enterprises, intends to promote agribusiness, attract private sector investment in agriculture, reduce post-harvest losses, add value to local agricultural products, develop rural infrastructure and enhance access of farmers to financial services and markets (IITA, 2008).

West Africa Agricultural Productivity Project (WAAPP) is expected to generate and disseminate improved technologies in the participating countries' target areas that are aligned with the region's top priorities, as identified by West and Central Africa Council for Agricultural Research. A number of ICRISAT bilateral projects seek to generate new improved agricultural technologies, seed systems, value addition and capacity building of National partners. Similarly ICRISAT operates several CGIAR Center Research Projects (CRPs), with leadership in the sorghum and millets components of the CRP portfolio (IITA, 2008).

Additional support is required to enable the strengthening of the Crop Development Process, strengthen the seed production and delivery systems for improved varieties, empower farmers to enable them manage their natural resource base in a sustainable manner using integrated soil fertility and

crop-livestock systems management (for example, livestock providing a better enterprise option for smallholder farmers), crop rotation (for example, the important of cash crops like cotton in terms of residual Phosphorus and Nitrogen for the subsequent legume and cereal crops, respectively), minimum or conservation tillage systems, expedite the scaling out of new sorghum and millets technologies including products development, enable Farmers' access to production inputs and markets, and strengthen and sustain the technology delivery system (Kostandini, 2015).

Taking into account the challenges that face the production of sorghum and millets and the opportunities that exist for their development and expansion, it is envisaged that the following pragmatic approaches will have the potential for increasing productivity, creating impact and improving the livelihood of smallholder farmers:

i. *Strengthen the Crop Development Process*: Maintain and strengthen the development of new, well-adapted sorghum, pearl millet, and finger millet cultivars with high yield potential and the genetic capacity to withstand major biotic and abiotic stresses. There is need to continue the breeding efforts, and to seek to strengthen the NARS institutions in the use of modern breeding platforms and methodologies (Klapwijk *et al.*, 2014).

ii. *Strengthen seed production and delivery systems for improved varieties*: Improving the efficiency and effectiveness of seed production and delivery systems is critical for enabling the uptake of improved cultivars by smallholder farmers in Western continent of Africa (WCA) and eastern and southern Africa (ESA). This is the basis for increased productivity in the semi-arid areas of the target countries, it will lead to availability of nutritious food for a majority of the population especially for children under the age of five years. Increased systems efficiency will make improved seed more affordable, and greater effectiveness will help ensure that quality standards are met and maintained. In partnership with a functional private sector and community based farmers organizations, the seed of improved cultivars and associated inputs will be made available at outlets closer to farmers (Dorward *et al.*, 2008).

iii. *Expedite the scaling out of new sorghum and millets technologies including products development*: This component should focus on raising awareness of new technologies, both with farmers and with those with mandate and/or incentive to provide farmers with access to technologies. Stimulated demand from farmers will create market opportunities for suppliers,



particularly for improved seed and input services (Kostandini, 2015).

iv. *Enabling Farmers' access to production inputs and markets:* A valid theory of change is that resource-poor smallholder farmers will adopt improved sorghum and millet technologies if they are relevant and made available, accessible and can be utilized, and that they have access to reliable markets to dispose of surplus production (Belt, *et al.*, 2015). Demand for productivity-enhancing inputs – seed and fertilizer – is largely derived from the product market. Existing use of improved inputs by smallholder farmers is limited both by inconsistent external demand on the output side, and lack of capacity to supply improved seed, fertilizer, finance, and know-how on the supply side. Efforts should be made to enable farmers to access both the inputs needed for production, and the markets for disposing of surplus farm produce (Dorward *et al.*, 2008).

v. *Strengthen and sustain the technology delivery system:* The agricultural extension services in many African countries are weak, at best, or non-existent. There have been many donor-inspired efforts to revamp agricultural extension in SSA, and the outcome has been discouraging, mainly because the national governments have been unable to match donor efforts in providing adequate resources and commitment to keep the system running beyond the lifetime of the donor funds. This lack of a strong, centrally-coordinated extension service has created a gap that many Farmer organizations and NGOs have tended to fill, to degrees that vary from country to country. There is need to formulate strong technology delivery programs and systems that ensure timely, accurate and location-specific information required by smallholder farmers for their decision-making process. Digital tools, such as the use of mobile phones and short text message (SMS) are helping to bridge this gap in some countries. But a lot more still need to be done to reach remote farmers (FAO, 2011).

vi. *Review of relevant agricultural policies:* In many countries in SSA, the policies governing many aspects that are central to agricultural production are in need of serious review. These include such critical aspects as seed certification, production and distribution, land ownership or tenure, gender relations and the rights of women to own property. Because some of these aspects have cultural roots, changing them is a slow long process which would need to go beyond mere changing the policies. But it is clear that efforts towards reforming such aspects are necessary and urgent (Evenson *et al.*, 2014).

vii. *Restoring degraded soils and ensuring sustainability:* In the Millet and sorghum based farming systems, soils are widely degraded and depleted of organic matter and plant nutrients (Lal, 2015). There is need to empower farmers to enable them manage their natural resource base in a sustainable manner using integrated soil fertility and crop-livestock systems management (for example, livestock provides a better enterprise option for smallholder farmers), crop rotation (for example, Cash crops like cotton can play an important role in the rotation in these systems in terms of residual Phosphorus (P) and Nitrogen (N) for the legume and cereal crops, respectively), minimum or conservation tillage systems. There is need for extension systems that enable farmers to continuously learn new ways of performing old tasks, as well as new tasks, to increase their production while sustaining the environment and their lands productive capacity (Toth *et al.*, 2018).

viii. *Understanding farm livelihoods and the potential impacts of interventions:* Farm households are highly heterogeneous entities, with multiple constraints of labour, capital and access to resources and operating in highly climatically variable environments (Adebayo and Kehinde, 2015). The use of systems analysis, encompassing the biophysical and socio-economic makeup of farm households are methodologies that use redeployable computer based modelling tools that can capture some of these complexities. Such methodologies, applied participatively with farmers and stakeholders create robust intervention strategies which more effectively lead smallholders out of poverty (IITA, 2008).

### **Challenges involved in sorghum and millets production**

The environments in which sorghum and millets are cultivated face the toughest environmental challenges, these include:

- i. How to overcome the inherently low productivity and profitability of dryland agriculture and manage the high risks faced. Underlying root causes of these include low and irregular rainfalls, high temperatures, poor soils and inappropriate agronomic practices (Adejuwon, 2013).
- ii. Dealing with the global problems of climate change and land degradation. As environments that are currently considered favourable for agriculture become hotter and drier over time, dryland cereals will become increasingly suited for production in areas where other

- crops are now grown (Adebayo and Kehinde, 2015).
- iii. The neglect and remoteness of the drylands that constrain the adoption of agronomic techniques and a greater role of market orientation and private enterprise in achieving development outcomes need to be addressed. Lack of investment in infrastructure such as roads, storage and market facilities handicap the potential role of the private sector. Modern digital technologies have the potential to meet these challenges and contribute to better communication and learning, and we will explore this (FAO, 2011).
  - iv. Rapid population growth across Africa, including its dryland areas, is giving rise to rapidly increasing demand for food, education, and employment opportunities – particularly for youth (Adejuwon, 2013). The United Nations (UN) Human Development Indices suggest that the dryland areas in West and Central Africa (WCA) and East and Southern Africa (ESA) remain among the poorest and most food-insecure places in the world. Some 25% of all children die before the age of five from hunger-related causes, and those who survive are often affected by poor physical development and reduced mental acuity (both the result of malnutrition). About half of the people living in these areas survive on only US\$1.25 per day or less (FAO, 2011).
  - v. Poor farmers do not have access to the resources needed to invest in new ways of doing business. The large potential productivity gains that are biologically possible in these areas, as shown by decades of research across a wide range of dry land locations, remain beyond the reach of most farmers in Africa (Gringset *al.*, 2013). The potential gains for sorghum and millets are as large as those derived from the Green Revolution in rice and wheat, and realizing even a modest portion of that potential would be transformative in the impoverished areas that are traditionally reserved for sorghum and millet production (Adebayo and Kehinde, 2015).
  - vi. The presence of counterfeit products, such as seeds, fertilizers, or other agro-chemicals, is a major constraint to development of efficient agricultural inputs markets in

much of Africa, and distrust engendered by counterfeits contributes to low levels of adoption of such inputs, especially in riskier environments (Gringset *al.*, 2013).

- vii. Weak national institutions: In many African countries, the institutions charged with the responsibility of spearheading the development of agriculture (for example, research, and extension service or value chain operators) are weak and often starved of operation funds and human capacity needed to effectively carry out their mandates. Many national research institutions are poorly equipped, and lack the critical technical mass needed to implement the complex scientific procedures that modern science demands, leading to high staff turnover, as good national scientists seek better opportunities, quite often overseas (Adejuwon, 2013).

#### **The way forward in sorghum and millet production**

The ongoing Sorghum Transformation Value Chain Project, of the Federal Ministry of Agriculture and Rural Development of Nigeria, seeks to increase sorghum production in the country by 2 million metric tons between 2011 and 2015, with the aim of improving nourishment and ensuring food and nutrition security through processing, and product development; and increase in productivity and profitability of sorghum through linking farmers with processors and markets (Balasubramanian *et al.*, 2009).

#### **Rice**

Rice has become a highly strategic and priority commodity for food security in Africa. Consumption is growing faster than that of any other major staple on the continent because of high population growth, rapid urbanization and changes in eating habits. It is the single most important source of dietary energy in West Africa and the third most important for Africa as a whole (Bouisset *al.*, 2011). Although local rice production increased rapidly after the 2007-2008 food crisis, a key problem facing the rice sector in Africa in general is that local production has never caught up with demand. The continent therefore continues to rely on importation to meet its increasing demand for rice (Secket *al.*, 2013). There is a great potential for accelerating agricultural productivity to achieve the green revolution that Africa urgently needs. Africa has sufficient land and water resources to produce enough rice to feed its teeming population. The potential



irrigable land in West Africa alone, estimated at about 8.9 million hectares of which less than 10% (920,000 hectares), is mostly utilized for rice and other crops. Irrigated rice production systems are considered the most promising because the highest rice yields per hectare are obtained under irrigation and in addition it offers the chance of two to three crops per year (Baudron, 2015). Rice consumption is increasing faster than that of any other staple food in Africa at about 5.5% per year. This increase is driven by urbanization and related changes in eating habits, and population growth. Rice consumption was approximately 24 million tonnes (Mt) per year in SSA in 2012. With only about 60% of rice consumption being satisfied by domestic production, rice imports stand at 10–12 Mt. This is equivalent to one-third of the rice traded on the world market (Secket *et al.*, 2012). Demand for milled rice in SSA is expected to increase by 30 Mt by 2035, equivalent to an increase of 130% in rice consumption. With the exception of Egypt, nearly all African countries rely on the unreliable international rice market, where only 7% of the global production is traded. Africa accounts for one-third of global rice imports at a cost that surpassed US\$ 5 billion in 2008 (Secket *et al.*, 2012).

### Challenges involved in rice production

According to Balasubramanian *et al.* (2009) and Bouiset *et al.* (2011), challenges facing the successful development of the African rice sector are huge and include the following:

- i. Choice of adequate production systems: The focus of African production systems has been on rain fed agriculture to the detriment of irrigated agriculture. Africa has the potential to irrigate 20% of its arable land (only 4% is currently irrigated). The choice of a balanced approach to the use of rice production systems presents an opportunity to be exploited (Balasubramanian *et al.*, 2009).
- ii. Fragmented rice value chain: The rice value chain is highly fragmented from production to marketing. Production is basically driven by small holder farmers who have as a primary target self-consumption (Grings *et al.*, 2013).
- iii. Lack of adequate rice milling facilities: The lack of rice milling facilities results in poor quality of the product, hence, poor competitiveness against imported rice (Secket *et al.*, 2012).
- iv. High production costs: High production costs in Africa reflect numerous production constraints. Yield levels are low due to a

number of abiotic and biotic stresses – in part highlighting seed renewal constraints for farmers, who often use antiquated varieties (Balasubramanian *et al.*, 2009)..

- v. Low agricultural inputs: In Africa, rice farmers have little or no access to farm inputs such as fertilizer and seeds. On average, 13 kg of fertilizer are applied per hectare in Africa compared with about 100 kg in Asia and as against over 150 kg in developed countries. The utilization of improved seeds is low in Africa (10% in Nigeria, and 25% in East Africa compared to 60% in Asia) (Bouiset *et al.*, 2011).
- vi. Inefficient scaling up and out models: It is relatively ineffective in Africa and access to services is poor (Grings *et al.*, 2013).
- vii. Poor mechanization: The low level of mechanization in African agriculture has continued to serve as a huge impediment towards advancing the sector, given the high cost of land clearing (Bouiset *et al.*, 2011). This in return results in the high cost of mechanization, which is a major disincentive for the expansion of cultivated areas. The use of mechanization from ploughing to harvesting, therefore poses great challenges to farmers across the continent. The number of tractors per 100 square kilometres in Nigeria is less than 10 in comparison to over 728 in the UK, 257 in the USA, 200 in India, 130 in Brazil, and 125 in the Philippines (Bouiset *et al.*, 2011).
- viii. Poor infrastructure: Most food products are unable to find their way to market due to weak market information, high transport costs, poor road infrastructure and networks (Secket *et al.*, 2012).
- ix. Lack of adequate human resources in the rice value chain: Most of the experienced rice scientists in the NARS programs in Africa are aging. Moreover, agricultural graduates are not in the Ministry of Agriculture, research institutions or on the farms. There is a need to increase the number and expertise of rice value chain actors including extension agents (Grings *et al.*, 2013).
- x. Inadequate policy environment: Most government policies are inappropriate and inconsistent, and do not provide an enabling environment for the development of the rice sector in Africa.



Despite these challenges, it is possible to transform the African rice sector into a competitive, income and employment generating sector using e-agriculture (Bouisset *et al.*, 2011).

### **The way forward in rice production**

African Rice and its partners have adopted the rice sector development hubs that represent key rice growing environments and market opportunities across African countries. The rice hubs are made to work for resource poor smallholder using multi-stakeholder innovation platforms (IPs). The IPs in the hubs are linked to major national and regional rice development efforts to facilitate broader uptake of rice knowledge and technologies (Childs, 2015). The African rice sector has the potential to become an engine for economic growth across the continent, contributing to eliminating extreme poverty and food insecurity. Good quality rice that can compete with imported rice requires a decent value chain approach using multi-stakeholder (Bouisset *et al.*, 2011). Africa must begin to transform the rice value chain segments as a business by growing the markets from “seed-to-table” or “farm-to-fork”. This requires bold reform by adopting market-friendly policies, committing more resources and bank lending to the sector, and creating an enabling environment for private-sector participation (Baudron, 2015).

Global ending stocks of rice are the lowest since 2007/08 and Thailand, a major rice exporter to Africa, is projected to reduce rice exports by 10%. Under this situation, if interventions are not made now, local markets in Africa may immediately experience severe shortage of rice in 2016 and this may be associated with socially unstable situations in rice growing areas, such as increases in poverty levels (Childs, 2015). It is our contention that the African continent will move from a food deficit to food surplus status when the problems in agriculture are considered as priority, and are seriously tackled through strong political will, positive changes in government’s attitude and the involvement of the youth and women (Bouisset *et al.*, 2011). This Africa Rice framework for Africa’s Agricultural Transformation Agenda contributes to the (i) strategy and roadmap for implementing the Malabo Declaration on accelerated African Agricultural growth and transformation, (ii) the results framework for the refreshed strategy of the Comprehensive Africa Agriculture Productivity Program, and (iii) relevant sustainable development goals (Seck *et al.*, 2013).

### **Wheat**

Wheat is grown on around 10 million ha in Africa. It is a major staple crop for several countries and an imported commodity in all of Africa. In all African countries, wheat consumption steadily increased during the past 20 years as a result of growing population, changing food preferences and socioeconomic change associated with urbanization. African countries are the world’s biggest wheat importer with more than 45 m t in 2013 at around 15 billion US\$. Wheat imports account for 60% of African’s wheat consumption and 80% of Sub-Saharan (SSA) countries (Ogunwole *et al.*, 2014).

According to Kolawale and Ojo (2010), North African countries have the highest per capita wheat consumption and wheat provides up to 50% of daily calories and protein. In rapidly urbanizing sub-Saharan Africa, wheat consumption is expected to grow 38% by 2023 with imports already at 23 m tons of wheat in 2013 at a cost of \$7.5 billion. Considering the growing importance wheat has for food security in Africa, African Union Heads of State endorsed their Agriculture Ministers’ endorsement in January 2013, to add wheat to the list of strategic crops for Africa. Increasing productivity of the small holder farmers, bridging the yield gaps by providing appropriate inputs along with improved technologies such as stress resistant and high yielding varieties will be a step towards agricultural transformation. There are wide range of challenges in the production of the major cereals crops (rice, maize, millet, sorghum and wheat) (Kolawale and Ojo, 2010).

Support is required to enable the generation of improved and sustainable wheat based technologies and innovations suitable for different agro-ecological zones of Africa, and enhance the sustainable dissemination, scaling-up and promotion of wheat based technologies and innovations along the value chain. In all African countries, wheat consumption has been steadily increasing during the past 20 years as a result of growing population, changing food preferences and a strong urbanization trend which has led to a growing ‘food gap’ in all regions, largely met by imports (USDA, 2014). Each year, less than 30% of wheat consumption in the region is covered from domestic production. In addition to the increasing trend in volume of wheat import in SSA, wheat prices (both producers’ and world market prices) have increased substantially over the last half-decade. Domestic price volatility is very high. Both price and volume of wheat imports already impose substantial challenges to many SSA countries on their foreign currency reserve and annual trade balance. Thus, for SSA countries, it is essential and timely to look into the exiting wheat production and productivity potentials and exploit

these potentials through putting proper policies, institutions and market arrangements in place and create incentives to all actors in the wheat value chain (Bouis *et al.*, 2011).

The average wheat productivity in SSA is 1.7 tons/ha, nearly 50% below the world average. The national average wheat productivity in SSA varies across countries. It ranges from 0.7 tons/ha in Burundi to 3.4 tons/ha in Mali. Yield data from experimental stations and crop models indicate a very high yield potential, among the highest reported for spring wheat. Therefore, the yield gap between yield potential and average farm yields is significant, often greater than 5-fold. This yield gap can be filled through use of improved technologies (improved varieties/seeds, agronomic practices, fertilizer and pesticides), and better institutional and market arrangements creating incentives to wheat producers and other actors involved in wheat marketing and processing (FAOSTAT, 2014).

The food crisis of 2008 and the socio-economic impacts it created worldwide resulted in an awakened attention on food security and the need for local production of staple food crops to minimize dependence on imports and meet the national needs for these crops. In 2010, AfDB initiated consultations among agriculturalists and specialists from its low-income Regional Member Countries (RMCs) and from CGIAR Centers working in Africa to address the need for food security in those countries. This has led to the launching of AfDB-funded project “Support to Agricultural Research for Development of Strategic Crops in Africa” (SRD-SCA), involving CGIAR Centers and other international and regional research institutions, all working in partnership with national research institutions, farmers and other stakeholders (AfDB, 2010).

Heads of State endorsed their Agriculture Ministers’ endorsement in January 2013, to add wheat to the list of strategic crops for Africa. Africa has the potential to become self-sufficient for wheat, through government commitment, appropriate policies and the contribution of female farmers and young people. This Wheat framework for Africa’s Agricultural Transformation Agenda contributes to the goal of greatly reduce Africa’s dependency on wheat import and on the long-term make Africa a wheat self-sufficient continent (FAO, 2014).

### **Challenges involved in wheat production**

i. North African countries have the highest per capita wheat consumption and wheat provides up to 50% of

daily calories and protein. Wheat is paramount for food security (AfDB, 2010).

ii. In rapidly urbanizing sub-Saharan Africa, wheat consumption is expected to grow 38% by 2023; in SSA, consumer demand for wheat is growing faster, at 5.1% p.a. (Mason, 2012).

iii. Rising food import bill: African countries are the world’s biggest wheat importer with more than 45 m t in 2013 at around 15 billion US\$. By 2020, 80% of wheat consumed in SSA will be imported, with 60% imports for Africa as a whole (FAO-UN, 2015). Imports draw on Forex holdings. Food bills hide import subsidies from exporting and importing countries. This does not represent a fair market for African wheat producers. Results suggest that the key drivers of rising wheat consumption in Sub-Saharan Africa are rising incomes, growing populations, women’s participation in the labor force increasing at a faster rate than men’s, and wheat food aid. Given population projections alone, wheat consumption in Sub-Saharan Africa is expected to increase at an even faster rate in the coming decades. Ethiopian farmers have obtained more than 8t/ha, new varieties introduced through SARD-SC in Nigeria yield up to 7t/ha. However, the yield gap between on-farm and potential yield remains very high, often greater than 5 fold. Wheat-based systems productivity, production and wheat quality in most of Africa are much lower than the potential (FAOSTAT, 2014).

iv. New, on a global scale extremely aggressive and virulent stem and yellow rust races (for example Ug99) emerge rapidly in Eastern and Central Africa, threatening local, regional and global production (Seck *et al.*, 2012).

v. Mechanization: Number of tractors and draught animals has been stagnating in sub-Saharan Africa and SSA smallholder agriculture is increasingly relying on labor, that is, human muscle power, while at the same time labor shortage becomes an issue. More than 50 per cent of the cropland in Eastern and Southern Africa is cultivated by hand. Tractors are only used on 20 to 25 per cent of the cropland, and on less than 10 per cent in Western and Central Africa. There is tremendous potential to introduce machinery that meets the demand of SSA small holder farmers (Bouis *et al.*, 2011).

vi. Many, especially small producers can’t provide quality and quantities (for example, stable yields) that African processors want to meet consumer demand. So they import (FAOSTAT, 2014).

Seck *et al.* (2012) revealed that, sub-Saharan Africa has a tremendous scope and potential for increasing bread



and durum (pasta) wheat productivity, whilst likely worst affected by climate change for example shortened growing seasons, erratic rainfall, increases in both day & night temperatures, new emerging diseases. Some of the highest spring wheat yields worldwide are obtained in African countries (Egypt, Ethiopia, Namibia, Zambia, Zimbabwe), but only by very few farmers. According to FAO (2014), the results of the IFPRI-CIMMYT simulation analysis provide strong evidence for the economic profitability and competitiveness of domestic wheat production for the selected SSA in African countries. These preliminary results based on large grid data require follow up on detailed regional and local analysis.

**Some opportunities in wheat farming, include the following:**

- i. Small and big farmers in specific African countries and agro-ecologies could produce more high quality wheat more profitably and sustainably. This becomes a source of stable cash-crop next to other farm (diversification) and non-farm income, if value chains function better (Baudron, 2015).
- ii. Very fast growing consumer demand offers great potential for generating value addition, larger and more diverse wheat-based markets and more inter-regional trade (wheat and finished wheat products) (Mason, 2012).
- iii. Change national and regional policies to incentivize effective flow of agricultural research to farmers, to develop a wheat seed sector that promotes faster access to high quality seed and value addition along the wheat value chain in-country/region (Seckel *et al.*, 2012).
- iv. Expand current projects activities (for example, Durable Rust Resistant Wheat, funded SARD-SC/AfDB; Ethiopian Wheat/USAID and others) focusing on breeding resistant varieties and providing seed to farmers. Through a greatly expanded effort, most rust susceptible wheat varieties should be replaced in East and Central Africa. This would greatly reduce the rust inoculum and thereby the chances that new races emerge from mutations and also make a great contribution to regional and global food security, since these virulent races can and have travelled to other global bread baskets in North Africa, Asia, Europe and Australia (AfDB, 2010).
- v. Increase farm power through appropriate-scale mechanization, so farmers can deal with labor shortage, livestock-related trade-offs, drudgery for women farmers (Mason, 2012).
- vi. Improved wheat varieties with high yield, heat and drought tolerance, pest and disease resistance, adequate

nutrition and processing characteristics, nitrogen use efficiency and in some regions acid soil tolerance (AfDB, 2010).

- vii. Replace yellow and stem rust susceptible varieties to reduce risk of epidemics and at same time reduce probability that new races emerge through reduced inoculum (Baudron, 2015).
- viii. Seed system innovations (get the right seed to farmers faster).
- ix. For all of the above, enhance sustainable scaling-up of technologies and innovations along the value chains through innovative platforms, exemplified by the SARD-SC project with continental coverage. They promote effective technology transfer by involving all stakeholders (Mason, 2012).
- x. Enable development of more efficient markets at national and regional levels. Consumer demand is there and predicted to grow even faster (AfDB, 2010).
- xi. Develop effective wheat value chain system, based on multi-stakeholder constraints and opportunities analyses (Baudron, 2015).

**The way forward in wheat production**

- 1. Generating improved and sustainable wheat based technologies and innovations suitable for different agro-ecological zones of Africa:
  - Improve wheat productivity and end use quality through breeding better varieties targeting irrigated and rain-fed wheat growing environments using latest technologies (Carswell, 2000).
  - Enhance and sustain wheat yields through better water/soil/crop integrated management and production packages (Defouret *et al.*, 2000).
  - Promote suitable wheat based systems that safeguard the natural resources while providing resilience and adaptation to climate change and close the significant yield gap (AfDB, 2010).
  - Establish / continue to operate precision phenotyping platforms: Egypt (yield potential); Sudan and Morocco (heat); Morocco (drought); Tunisia (Septoria durum wheat); Ethiopia (stem rust durum and bread wheat; yellow rust bread wheat); Kenya; stem and yellow rust bread wheat) (Carswell, 2000).
  - Increase farm power through appropriate-scale mechanization, so farmers can deal with labor shortage, livestock-related trade-offs, drudgery for women farmers (Baudron, 2015).



2. Enhancing sustainable dissemination, scaling-up and promotion of wheat based technologies and innovations along the value chain and with continental coverage:

- Establish and operationalize innovative platforms (IP) for promoting effective technology transfer pathway through involving all stakeholders along the wheat value chain (FAO, 2014).

- Disseminate and scaling up proven wheat technologies using developed SARD-SC wheat project using IP approaches to new areas and countries of similar agro-ecologies based on the findings of similarity studies for a wider impact with continental coverage (Berckmoeset *et al.*, 1990).

- Develop diverse and sustainable seed systems with the participation of various stakeholders to fast-track the production of quality seed, with affordable price and timely delivery at community level in target countries (Van Dijk *et al.*, 2004).

- Develop an effective wheat value chain system to create market outlets for farmers and stakeholders by identifying constraints faced by a diversity of actors and by setting key strategic interventions for promoting wheat production, processing and marketing along the value chain (Carswell, 2000).

- Evaluate in detail potential (biology, value chain) for wheat production in non-traditional wheat growing regions / countries identified in CIMMYT/IFPRI large scale analysis (FAO, 2014).

- Creating a favorable and enabling policy environment to encourage private sectors and to facilitate farmer access to credit, production inputs, machinery and wheat markets. Consequently, domestic wheat production can become more competitive by improving marketing efficiency and lowering transaction costs, and by designing policies, institutions and infrastructure to reduce the costs of acquiring inputs and marketing wheat (Anne, 2009).

- Developing and expanding innovative small-scale agri-businesses within the established Innovation Platforms across all project intervention sites and countries for creating job opportunities, including women and youth in the rural areas (Bremner *et al.*, 1987).

3. Strengthening the capacities of project stakeholders

- Upgrading the capacity of value chain actors in Research and Development through need-based training and skill development (Binsbergen *et al.*, 2004).

- Reinforce institutional research for development capacity through the development of research infrastructure and acquisition of key equipment strengthening research for development at national, regional and CG systems based in Africa (Defouret *et al.*, 2000).

- Establishing and promoting continental and sub-regional networks to facilitate exchange of technologies, experience sharing, and for strengthening linkage and partnership (Binsbergen *et al.*, 2004).

All in all, realizing the full potential of wheat for food security in Africa requires developing suitable and target oriented varieties and technological packages; making affordable inputs available; building effective and sustainable wheat seed systems; making wheat extension systems more efficient and effective; increasing productivity among smallholders; establishing and strengthening the capacity of farmers and farmers organization; developing value chains for input supply, and output markets; fostering regional co-operation; putting in place appropriate policies that foster wheat industry; and political will to realize and harness Africa's wheat potential (Anne, 2009).

### Conclusion

It is believed that, the African continent will move from a food deficit to food surplus status when the problems in agriculture are considered as priority, and are seriously tackled through strong political will, positive changes in government's attitude and the involvement of the youth and women. This Africa cereal framework for Africa's Agricultural Transformation Agenda contributes to the (i) strategy and roadmap for implementing the Malabo Declaration on accelerated African Agricultural growth and transformation, (ii) the results framework for the refreshed strategy of the Comprehensive Africa Agriculture Productivity Program, and (iii) relevant sustainable development goals (Seck *et al.*, 2013). Linkage should be formed with initiatives that are developing sustainable models of seed supply, such as AGRA's Programme for African Seed Systems (PASS), which supports private seed companies and village-based agro-dealers. This linkage is essential to ensure that the demand for improved seed created by various initiatives will continue to be met in a sustainable manner. Scaling-out efforts should aim at making sorghum and millet growers in the target regions aware of new technologies, while also allowing farmers to test new varieties and associated best management practices for themselves. They should also leverage current and emerging interest from those service providers (Community, NGO and private sector especially flour mills for composite with wheat) looking to service the smallholder farming sector.

Similarly it is important to develop sorghum and millet products for the urban market, since this will encourage commercialization of the crops (AfDB, 2010).

## References

- Adebayo, O., & Kehinde, O. (2015). Impact of Agricultural innovation on Improved Livelihoods and Productivity among Small Farmers in Rural Nigeria. A working Paper 2015/07, Maastricht school of Management.
- Adejuwon, S.A. (2013). Impact of climate variability and climate change on crop yield in Nigeria. *Agricultural Production*, 43 (4), 32-34.
- African Development Bank (AfDB) (2010). <http://afdb.org> Director General of Africa Rice, Co-conveners: Tabo Ramadjiata. Retrieved 23<sup>rd</sup> September 2011.
- Anne, R. (2009). Livelihood Strategies in a globalizing World. Analysis of Farmers' Strategies in Southern Mali with Emphasis on Milk Production. Published M.Sc. Thesis Rural Sociology and Plant Production Systems.
- Alene, A. D. (2009). The Economic and Poverty Impact of Maize Research in West and Central Africa. *Agricultural Economics*, 40, 535-550.
- Balasubramanian, V., Sie, M., Hijmans, R., & Otsuka, K. (2009). Increasing Rice Production in Sub-Saharan Africa: Challenges and Opportunities. *Advances in agronomy*, (94), 55-133.
- Baudron, E. (2015). Re-examining Appropriate Mechanization in Eastern and Southern Africa: Two-wheel Tractors, Conservation agriculture, and Private Sector Involvement. *International Journal of Agriculture and Food Security*, 2(11), 37-40.
- Belt, J., Kleijn, W., Pauline, A. C., Elton, m., Gomo, M., & Mfula, C. (2015). Making input accessible for smallholder farmers in Africa. Market base solution for inputs supply. [www.snv.org](http://www.snv.org) > [snv-kit](http://www.snv.org). Retrieved 11<sup>th</sup> June, 2018.
- Berckmoes, W. M. L., Jager, E.J., & Koné, Y. L. (1990). *Intensification agricole au Mali Sud; Souhait ouréalité* Institute Royal des Tropique (KIT), Amsterdam.
- Binsbergen, van W., & Dijk van R., (2004). Situating Globality; African Agency in the Appropriation of Global Culture, In: *Situating Globality*; Brill Leiden. *African Culture Bulletin*. (12), 33-36.
- Bouis, H. E., Hotz, C., McClafferty, B., Meenakshi, J. V., & Pfeiffer, W. H. (2011). Biofortification: a new tool to reduce Micronutrient Malnutrition. *Food Nutr. Bulletin*. (32), 31-40.
- Breman, H., & Traoré, N. G. (1987). *Analyse des conditions de l'élevage et propositions de politiques et des programmes. Mali, SAHEL D (87)302 OCDE/CILSS/Club du Sahel*. Paris.
- Carswell G., (2000). Agricultural intensification in Ethiopia and Mali, IDS research report 48, Institute of development studies, England.
- Childs, N. (2015). Rice Outlook. <http://www.ers.usda.gov/media/1902020/res-15i-final.pdf> Retrieved 10<sup>th</sup>/07/2015.
- Defour, T., Budelman, A., Toulmin, C., & Carter, S.E. (2000). Managing soil fertility in the tropics. Building common knowledge: Participatory learning and action research 1 (3<sup>rd</sup>ed) Amsterdam, the Netherlands: Royal tropical Institute Press.
- Dorward, A., Ephraim, C., & Collins, P. (2008). Improving access to inputs and outputs Markets. Research paper: Future Agriculture. [www.futureagriculture.org](http://www.futureagriculture.org) Retrieved 7<sup>th</sup> November, 2018.
- Evenson, R. E. Habito, A. R., Quisumbing, C. S., & Bantilan, G. (2014). Methods for Agricultural Policy Analysis: an Overview. *Journal of Philippine Development*. No: (23), 13
- Fisher, M. (2015). Drought Tolerant Maize for Farmers adaptation to drought in Sub-Saharan Africa: Determinants of adoption in Eastern and Southern Africa. *African Journal of Agriculture, "Climate change"* 2(10): 1007-1058.
- Food & Agriculture Organization (FAO) (2005). Bridging the rural digital divide food and agriculture organization. Rome, Italy. 1.
- Food and Agricultural Organization (FAO) (2011). The state of Food and Agriculture. Women in Agriculture. Closing the Gender gap for Development. 4(12), 56-65.
- Food and Agricultural Organization Statistics (FAOSTAT) (2015). <http://faostat.fao.org>. Retrieved October 6, 2015. ICRISAT (21-23 Oct. 2015).



An action plan for African Agricultural Transformation.

Food Agriculture Organization Statistics (FAOSTAT). (2014). Cereal Crop Farming in Sub-Saharan Africa (SSA). Available at: <http://Faostat.fao.org> Retrieved 14<sup>th</sup> June 2014.

Food Agricultural Organization (FAO). (2011). The State Food and Agriculture. Women in Agriculture. Closing the Gender gap for Development. *International Journal of Agriculture*. 3(10), 87-90.

Food and Agriculture Organization of the United Nations (FAO). (2014). E-agriculture a definition and profile of its application. <http://www.fao.org/rdd/doc/e-agriculture-10-051.pdf> Retrieved 22<sup>nd</sup> October, 2015.

Food and Agriculture Organization of the United Nations (FAO-UN). (2015). Agricultural outlook. OECD Paris, Publishing.

Grings, E., Erenstein, O., & Blummel, M. (2013). Special Issue: Dual- Purpose Maize. *Field Crops Research* (153), 1-12.

D. C.

Idem, N.U.A., & Showeminu, F. S. (2011). Cereal Crop of Nigeria. *African Journal of Agricultural Research*. 16-34.

International Farmers Programmes Research Institute (IFPRI). (2000). 2020 Projection. Washington D. C.

International Institute for Tropical Agriculture (IITA) (2008). The use of GPS units to Geo- Reference Experimental Data. [www.fao.org/temprep/docrep/fao](http://www.fao.org/temprep/docrep/fao). Retrieved 6<sup>th</sup> February, 2008.

Ismaila, U., Gana, A. S., Tswana, N. M., & Dogara, D. (2010). Cereal production in Nigeria, Problems, Constraints and Opportunities for betterment. *African Journal of Agricultural Research* 5(2), 1341-1342.

Kamara, A. Y. (2008). A Participatory Approach to increasing Productivity of Maize through *Striga hermonthica* control in Northeast Nigeria. *Experimental Agriculture*. 44(3), 349-364.

Klapwijk, C. J., van Wijk, M. T., Rosentock, T. S., van Asten, P. J. A., Thornton, P. K., & Giller, K. E. (2014). Analysis of trade-offs in agricultural systems: Current Status and way forward. *Current Option in Environmental Sustainability*, 6(0), 110-115.

Doi: <http://dx.doi.org/10.1016/j.cosust>. 2013. 11. 012.

Kostandini, G., La Rovere, R., & Zhe, G. (2015). Ex-ante welfare analysis of technological change: the case of Nitrogen Efficient Maize for African Soils. *Canadian Journal. Agri. Econ.* (DOI: 10.1111/cjag.12067).

Kolawale, O., & Ojo, S. O. (2010). Economic Efficiency of Small Scale Food Crop Production in Nigeria. *Journal of Social Sciences*. 14(2), 123-130.

Lal, R. (2015). Restoring Soil Quality to Mitigate Soil Degradation. Doi: 10.3390/su7055875. The Ohio State University, Columbus. OH 43210, USA Academic Editor: Marc A. Rosen. *Sustainability*: 7(5), 5875-5895. Retrieved 13<sup>th</sup> May, 2015.

Mahuku, G. (2015). Maize Lethal Necrosis (MLN), an emerging threat to maize-based food security in sub-saharah Africa. *Phytopathology* (105), 956-965.

Mason, R. (2012). Wheat Consumption in Sub-Sahara Africa: Trends, Drivers, and Policy Implications, MSU International Development Working Paper 127, December.

Nuss, E.T., & Tanumihardjo, S. A. (2011). Quality Protein Maize for Africa: Closing the protein inadequacy gap in vulnerable populations. *Adv. Nutrition. OECD/FAO Organization of the United Nations (OECD) Publishing, Paris.* (2), 217-224.

Ogunwole, J. O. Bello, A.L., & Owonubi, A.T. (2014). Environmental Characterization of Cereal Producing Areas of Nigeria. *International Journal of Agricultural Research*. 4 (12), 98-112.

Prasanna, B., Mahuku, G. (2015). Maize Lethal Necrosis (MLN) in eastern Africa: tackling a major Challenge. *The Africa Seed* (March 2015 Issue), 18-21.

Seck, P. A., Diagne, A., Mohanty, S., & Wopereis, M. C. S. (2012). Crops that feed the world 7: rice. *Food Security* 4(1), 7-24.

Seck, P. A., Toure, A. A., Coulibaly, J. Y., Diagne, A. & Wopereis, M. C. S. (2013). Impact of Rice Research on Income, Poverty and Food Security in Africa: an ex-ante analysis. In: Wopereis, M. C. S., Johnson, D. E. Ahmadi, N., Tollens, E., & Jalloh, A. (Eds.), *Realizing Africa's Rice Promise*. CAB International, UK, Wallingford, 24-33.



Smale, M. Byerlee, D. & Jayne, T. (2011). Maize Revolution in sub-Saharan Africa. Policy Research working paper. Washington DC: World Bank. Pp. 56-59.

Tahirou, A. (2009). Assessing the constraints affecting production and development of maize seed in DTMA Countries of West Africa. IITA, Ibadan, Nigeria, 40

Toth, G., Hermann, T., Ravina, M., & Montanarella, L. (2018). Monitoring Soil for Sustainable

Development and Land Degradation: Environmental Monitoring and Assessment. Springer Nature Switzerland AG. 197-210. Retrieved 4<sup>th</sup> February, 2018.

Van Dijk H., Bruijn de M., Beek van W. (2004). Pathways to mitigate climate variability and climate change in Mali: The districts of Douentza and Koutiala compared. In: Dietz A.J., Ruben R., Verhagen A., The Impact of Climate Change on Drylands with a focus on West Africa. Kluwer Academic Publishers.



# PERFORMANCE OF SOYBEAN GENOTYPES UNDER RHIZOBIA INOCULATION ACROSS THREE AGRO ECOLOGIES OF NIGERIA

Tolorunse<sup>1\*</sup>, K. D., Gana<sup>1</sup>, A.S., Sangodele<sup>2</sup>, E. A. and Ngwu, C. H.

Department of Crop Production, Federal University of Technology, Minna, Nigeria.

<sup>2</sup>Olam Crown Flour Mill, Km 25, Kaduna-Abuja Express way, Kaduna, Nigeria

\*Corresponding Author's E-mail: [kehinde.tolorunse@futminna.edu.ng](mailto:kehinde.tolorunse@futminna.edu.ng) GSM: 07036411724

## ABSTRACT

*There is need to improve soybean yield potentials per unit area in the tropics, at least to the world average productivity level. To achieve this, attention has to be paid to the selection of high yielding and stable genotypes through plant breeding improvement programmes. Twenty four soybean lines were investigated across three agro ecological zones in Nigeria to determine their productivity. In each of the sites, the experiments were laid out in randomized complete block design with three replications. Data were collected on growth and yield parameters. Results indicated that seven lines (TGx 1987-10F, TGx 1990-55F, TGx 1990-46F, TGx 1990-57F, TGx 1989-49FN, TGx 1989-48FN and TGx 1989-40F) were identified to be high yielding in both Northern and Southern Guinea Savannah, while TGx 1989-40F was high yielding in Sudan Savannah. This indicates that environmental differences could be responsible for soybean productivity from one agro ecology to another. Therefore, soybean lines could be recommended for cultivation according to their performances in a given environment.*

**KEYWORDS:** Soybean, Agro ecology, Performance, Interaction

## INTRODUCTION

Soybean (*Glycine max* (L.) Merrill) is a legume native to East Asia perhaps in North and Central China (Laswai *et al.*, 2005) and belongs to the family Leguminosae. Soybean has been recognized as one of the premier agricultural crops today, thus it is the best source of plant protein and oil and has now been recognized as a potential supplementary source of nutritious food (Wilcox and Shibles, 2001). It has been found to substitute other sources of good quality protein such as milk, meat and fish. Therefore, it has become very suitable to other protein sources that are scarce or too expensive to afford (Asrat *et al.*, 2009).

Soybean contains a good quality protein of 42 % and 19.5 % oil (Wilcox and Shibles, 2001). Soybean protein is considered complete, because it supplies sufficient amounts of the types of amino acids that are required by the body for building and repair of tissues (Jinze, 2010). Essential amino acids found in soybean are methionine, isoleucine, lysine, cystine, phenylalanine, tyrosine, theonine, tryphophan as well as valine (Bellaloui *et al.*, 2009). Amino acids are used in the formation of protoplasm, the site for cell division and therefore facilitate plant growth and development. Soybean has been found to have different uses; for example in food industry, soybean is used for flour, oil, cookies, candy, milk, vegetable cheese, leathin and many other products (Coskan and Dogan, 2011).

There is need to improve on soybean yield potentials per unit area in the tropics, at least to the world average productivity level. To achieve this, attention has to be paid to the selection of high yielding and stable genotypes through plant breeding/improvement programmes. In plant improvement programmes, knowledge of the genetic variability and the adequate evaluation of breeding materials under several environments are of paramount importance. With the identification of high-yielding and well-adapted soybean genotypes, breeders can make recommendations to farmers, for soybean production in specific environments and across environments, which is expected to address the yield gap presently experienced in Nigerian agro ecologies. Therefore the objectives of the study was to evaluate the performance of soybean lines in individual environments and across environments, evaluate yield stability of the lines across the three environments and select superior advanced lines in the test environments for yield evaluation trial.

## METHODOLOGY

The study was conducted during the 2015 and 2016 rainy seasons at three experimental sites across three different agro-ecologies of Nigeria. The experimental sites were; Abuja (Southern Guinea savanna) Latitude 9.52335N and Longitude 6.44791E, Igabi (Northern Guinea savanna) Latitude 10.94427N and Longitude 7.64443E, Gwarzo (Sudan savanna) Latitude 11.92996N and Longitude 7.98789E. The

experimental treatment was a factorial combination of 24 soybean genotypes (TGx 1989-11F, TGx 1990-110FN, TGx 1989-42F, TGx 1990-95F, TGx 1989-45F, TGx 1990-114FN, TGx 1989-53FN, TGx 1993-4FN, TGx 1989-75FN, TGx 1990-78F, TGx 1987-62F(Check), TGx 1448-2E(Check), TGx 1989-40F, TGx 1990-52F, TGx 1989-48FN, TGx 1990-40F, TGx 1989-49FN, TGx 1990-57F, TGx 1989-68FN, TGx 1990-46F, TGx 1990-55F, TGx 1987-10F(Check), TGx 1835-10E(Check), TGx 1485-1D(Check)) and three inoculation types (Without Inoculation, LegumeFix and NoduMax) fitted into a Split-plot design with three replications. The main plots consisted of the soybean genotypes and the sub-plots were the inoculation types. Gross plot size was 3 m × 4 m (12 m<sup>2</sup>) containing five ridges of 3 m long each. Net plot size was 3 m × 2.5 m (7.5 m<sup>2</sup>). An alley of 1 m was used to separate the blocks, and 0.5 m for the treatment plots. The experimental field in each location was ploughed, harrowed and ridged with tractor. Then followed by field layout in which 216 sub-plots were marked out as per the treatments. Single super phosphate (SSP) was applied by hand at the rate of 40 kg P<sub>2</sub>O<sub>5</sub> ha<sup>-1</sup> at 2 weeks after sowing, using side placement method of fertilizer application. Cypermethrin (Best) at the rate of 0.14 kg a.i ha<sup>-1</sup> (Afolayan and Braimoh, 1991) was applied once on the seedlings with knapsack sprayer to control insect pests infestation. In each of the location and year of research, seed yield was taken in which seeds were separated from the husk and kept in labelled bags representing respective plots and then converted to kilogram per hectare. Data collected were subjected to Analysis of Variance (ANOVA) using General Linear Model (GLM) procedure of SAS (SAS, 2003). Level of significance was determined at 5%. Means were separated using Duncan Multiple Range Test at  $p = 0.05$ . To determine genotypic sensitivity and stability, linear regression and correlation model was used (Eberhart and Russell, 1966). Additive Main Effect and Multiplicative Interaction (AMMI) were used to determine the stability pattern of the genotypes across the locations (Adie and Krisnawati (2015); BMS, 2015). The AMMI model is  $Y_{ij} = \mu + g_i + e_j + \sum \lambda_k \alpha_{ik} \gamma_{jk} + \varepsilon_{ij}$ .

Where  $Y_{ij}$  is the mean of the  $i$ th line in the  $j$ th environment,  $\mu$  is the grand mean,  $g_i$  is the genotype effect,  $e_j$  is the site effect,  $\lambda_k$  is the singular value for principal components  $k$ ,  $\alpha_{ik}$  is the eigenvector score for genotype  $i$  and component  $k$ ,  $\gamma_{jk}$  is the eigenvector score for environment  $j$  and component  $k$ , and  $\varepsilon_{ij}$  is the error for genotype  $i$  and environment  $j$ .

## RESULTS AND DISCUSSION

Table 1 shows seed yield of soybean as affected by genotypes and inoculation during the 2015 and 2016 cropping seasons and the combined data at the Abuja site. Seed yield was significant among the genotypes and the inoculation applications at both cropping seasons and their combined data. TGx 1990-110FN, TGx 1990-46F, TGx 1989-45F, TGx 1989-49FN and TGx 1990-55F recorded significantly higher seed yield during the 2015 cropping season while TGx 1990-95F had the least yield during the same cropping season. In 2016 cropping season, TGx 1990-46F produced the highest yield but not significantly different from four other entries. Also, the combined data revealed that TGx 1990-46F and TGx 1989-49FN had significantly higher yield compared to other entries. The result of inoculation indicated that plants without inoculation produced significantly lower yield at both cropping seasons and the combined data. Furthermore, the interaction between genotypes and inoculation was not significant except during the 2016 cropping season. Seed yield were generally higher in plants inoculated with either NoduMax or LegumeFix compared to those plants without inoculation (Table 2). Among the inoculated plants, irrespective of the inoculants, TGx 1990-110FN, TGx 1989-49FN and TGx 1990-46F produced higher yield, similar to those produced by NoduMax-inoculated TGx 1989-48FN, TGx 1990-40F and the LegumeFix-inoculated TGx 1989-42FN, TGx 1989-68FN and TGx 1990-55F plants. These were similar in yield as the checks TGx 1835-10E(Check), TGx 1835-10E(Check), TGx 1967-62F(Check) and TGx 1987-10F(Check) (Table 2). In the combined data, all the growth and yield attributes measured correlated positively and significantly with the seed yield (Table 3). The strongest relationship between any two growth parameters and seed yield in the combined data, was that between 100-seed weight and seed yield ( $r = 0.889^*$ ). This was in turn also the strongest relationship between any two growth parameters recorded. Table 9 indicated the combined analysis for sensitivity and stability coefficients for seed yield from soybean genotypes across environments during the 2015 and 2016 cropping seasons. TGx 1989-19F recorded mean seed yield (1577 kg ha<sup>-1</sup>) greater than average mean 1570 kg ha<sup>-1</sup> and showed average genotypic sensitivity ( $b = 1$ ) hence averagely stable. Also, five genotypes TGx 1990-40F, TGx 1989-11F, TGx 1990-52F, TGx 1448-2E(Check) and TGx 1990-55F recorded more than average mean performance and above average sensitivity, thus less stable. Furthermore, four genotypes, TGx 1989-45F, TGx 1989-75FN, TGx 1990-110FN and TGx 1990-95F had more than



average mean performance and below average sensitivity ( $b < 1$ ) making it more stable.

The genotype and environment interaction clearly plays a significant role in breeding adaptable genotypes to the wide environment. This interaction was validated by the highly significant difference for seed yield. These results relate the findings of Gebeyehu and Assefa (2003) who reported that selections based on the highest yielding genotypes appeared less stable than the average of all genotypes. Furthermore, Gebeyehu and Assefa (2003) stated that selection solely for seed yield could result in rejection of several stable genotypes. TGx 1989-45F and TGx 1990-110FN out yielded others because of its yield components such as plant height, number of leaves, number of pods per plant and some other growth traits that have contributed to the high yield. In contrast, Arslanglu and Aytac (2010) reported contrary finding on the effect of genotype, environment and genotype by environment interaction on soybean pod number per plant, whereby plant height, seed yield and one hundred-seed weight were found to be significant at ( $P=0.01$ ). From the findings of this study, it was evident that total biomass yield and seed yield declined in the same trend. The mean performance analysis revealed that high yielding genotypes across the environments over the two years were TGx 1989-45F, TGx 1990-110FN and TGx 1989-53FN. Thus, the outstanding performance by TGx 1989-45F in terms of yield and yield related traits made it the best performer across the three environments over two years. These conform to Egli (1998) explanation for soybean performance that yield variation across environments and years was associated with changes in number of seeds per unit area. A contrary explanation is that an ideal soybean cultivar is one that achieves the greatest yield across many environments (Fasoula and Fasoula, 2002). The exhibited non-significance by these traits, number of branches per plant, number of pods per plant and one hundred-seed weight was confirmed by Baker (1988) who defined the non-significant difference as failure of genotypes to achieve the same relative performance in different environment. Thus, the genotype by environment interaction might have made it difficult for breeders to identify the best genotypes, during selection and recommendation. The positive and significant correlation estimated between seed yield and other traits agreed with the findings of Malik *et al.* (2006). This implies that selections aimed at increasing seed yield would invariably select for higher plant height, higher leaf number and earliness to flower and as against one hundred-seed weight, number of branches per plant

and number of pod per plant. This finding was in agreement with Karasu *et al.* (2002) who revealed that crop yield variations are strongly influenced by growth and yield parameters. The positive correlation reported agrees with Maesri *et al.* (1998) whereas, Rajanna *et al.* (2000) were of the view that one hundred-seed weight had negative association with seed yield. The positive correlation of number of pods per plant with seed yield obtained conformed to Karasu *et al.* (2002) study in Turkey. But Haliloglu *et al.* (2007) reported a contradictory result that the number of pods per plant indicated a positive association with seed yield. On the other hand, the positive correlation estimated between number of branches per plant and seed yield, total biomass yield, number of pods per plant agrees with Malik *et al.* (2007). Thus the correlation estimation in this study clearly defines the contribution of various other traits such as plant height, number of leaves, branches per plant and total biomass yield to seed yield through path analysis. The highest and the lowest seed yields level attained by the genotypes were mostly due to plant height, number of leaves, number of branches per plant and number of pods per plant. In this study, it could be cited that the correlation coefficient of the genotypes across the environments in two years indicated that plant height had significant correlation with seed yield. This finding conformed to the report of Rajanna *et al.* (2000). Although number of branches per plant correlated non-significantly with other traits, positive trend was recorded. The chlorophyll content was significantly associated with seed yield. This indicated that with the greenish nature of the leaves more efficient utilization of solar radiation could be achieved. The finding was in agreement with Kumudini *et al.* (2001) who explained that the higher the chlorophyll content, the more improved the yield due to increased intercepted solar radiation and enhanced carbon exchange rate. The little variability recorded among genotypes was due to their response to climate changes in the three environments. This agrees with Kang (1998) findings that environment played major role in phenotypic expressions of agronomic traits. To overcome genotype by environment effect, Cucolotto *et al.* (2007) partitioned genotype by environment interaction into two; adaptability and phenotypic stability. These researchers defined adaptability as the capability that a genotype has to make use of the environmental effects that warrants a high yield level and phenotypic stability was related to yield maintenance or yield predictability in diverse environment. However, in the present study, genotype by environment was not partitioned. Phenotypically, all the studied genotypes followed similar trend of

performance over two years. The non-significant differences posed by genotype by environment were confirmed by Faisal (1986) who reported that traits do influence performance and seed yield. The yield variations explained by environments indicates that the environments were diverse, with large differences between environmental means contributing most of the variations in yield. According to Eberhart and Russell (1996), an ideal cultivar would have both a high average performance over a wide range of environments plus stability. Although genotypic main effect was highly significant this shows difference in genotypic performance across environments resulting in genotype by environment interaction. The existence of genotype by environment interaction raised the need to identify stable and high yielding genotypes.

#### **CONCLUSION AND RECOMMENDATIONS**

Out of the twenty-four genotypes evaluated for genotype by environment interaction and yield stability, two (TGx 1989-45F and TGx 1990-110FN) were identified by the analytical tools used as the overall best in relation to seed yield and stability as compared to the checks and grand mean performance of the genotypes. In terms of the environment, Gwarzo produced the least interaction scores, while Abuja and Igabi produced the highest interaction scores. Therefore, Gwarzo was most stable than Abuja and Igabi. However, the average yield performance of Gwarzo was poor when compared with the yield performance of the other two environments.

**Table 1: Mean seed yield (kg ha<sup>-1</sup>) of soybean as affected by genotypes and inoculation during the 2015 and 2016 cropping seasons across the environments**

Treatment	2015	2016	Combined
<b>Genotypes (G)</b>			
TGx 1989-11F	1659.2cd	1545.1dc	1602.1c
TGx 1990-110FN	2717.5ab	1839.0ab	2278.3a
TGx 1989 -42FN	1590.6cd	1676.5bc	1633.6c
TGx 1990 -95F	1514.2d	1544.6cd	1529.4c
TGx 1989-45F	1989.8ab	1820.1ab	1905.0ab
TGx 1990-114FN	1558.8cd	1611.3cd	1585.0c
TGx 1989-53FN	1613.0cd	1498.9d	1556.0c
TGx 1993-4FN	1581.8cd	1601.0cd	1591.4c
TGx 1989-75FN	1573.1cd	1592.3cd	1582.7c
TGx 1990-78F	1563.6cd	1582.8cd	1573.2c
TGx 1967-62F(Check)	1722.7bc	1738.6bc	1730.7bc
TGx 1448-2E(Check)	1658.7cd	1655.7bc	1657.2c
TGx 1989-40F	1583.3cd	1647.0bc	1615.2c
TGx 1990-52F	1657.3cd	1693.2bc	1675.3c
TGx 1989-48FN	1752.9bc	1816.5bc	1784.7bc
TGx 1990-40F	1699.1bc	1762.7bc	1730.9bc
TGx 1989-49FN	1996.4ab	1982.3ab	1989.4ab
TGx 1990-57F	1707.4bc	1771.1bc	1739.2bc
TGx 1989-68FN	1696.7bc	1727.0bc	1711.9bc
TGx 1990-46F	2060.0a	2145.9a	2102.9a
TGx 1990-55F	1859.5ab	1801.0bc	1830.2bc
TGx 1987-10F(Check)	1741.8bc	1794.4bc	1768.1bc
TGx 1835-10E(Check)	1743.7bc	1851.9ab	1797.8bc
TGx 1485-1D(Check)	1753.0bc	1872.2ab	1812.6bc
±SE	112.7	109.3	122.2
<b>Inoculation(I)</b>			
Without inoculation	1204.0c	1250.2b	1239.7c
NoduMax	1882.1b	1912.8a	1892.0b
LegumeFix	1988.1a	2008.3a	1991.0a
±SE	38.3	42.0	39.5
<b>Interaction</b>			
G x I	NS	*	NS

Means followed by the same letter(s) within a set of treatment column are not significantly different at P=0.05 using DMRT; NS= Not significant;

\*= Significant at P=0.05; SE = Standard error



**Table 2: Interaction effect of genotypes and inoculation on the seed yield (kg ha<sup>-1</sup>) of soybean during the 2016 cropping season across the environments**

Genotypes	Without inoculation	NoduMax	LegumeFix
TGx 1989-11F	1189.1j	1530.9f	1915.2b
TGx 1990-110FN	1299.4i	2118.3a	2099.3a
TGx 1989 -42FN	1236.1i	1777.5d	2016.0a
TGx 1990 -95F	1185.6j	1836.3c	1611.8e
TGx 1989-45F	1122.7j	1965.6b	1772.1d
TGx 1990-114FN	1172.6j	1746.4d	1915.0b
TGx 1989-53FN	1158.9j	1701.9d	1636.0e
TGx 1993-4FN	1197.9j	1828.7c	1776.4d
TGx 1989-75FN	1270.5i	1743.7d	1762.6d
TGx 1990-78F	1181.5i	1696.4e	1870.7c
TGx 1967-62F(Check)	1238.1i	1814.3c	2163.5a
TGx 1448-2E(Check)	1317.6h	1734.7d	1914.9b
TGx 1989-40F	1317.8h	1874.3c	1748.8d
TGx 1990-52F	1244.3i	1931.3b	1904.0b
TGx 1989-48FN	1345.6h	2125.2a	1978.7b
TGx 1990-40F	1212.7i	2148.9a	1926.5b
TGx 1989-49FN	1168.3j	2229.3a	2549.3a
TGx 1990-57F	1329.9h	1904.0b	2079.1a
TGx 1989-68FN	1341.6h	1759.0d	2080.3a
TGx 1990-46F	1326.8h	2588.8a	2521.9a
TGx 1990-55F	1144.8i	1911.6b	2346.3a
TGx 1987-10F(Check)	1314.1h	1987.0b	2081.8a
TGx 1835-10E(Check)	1245.0i	2025.7a	2284.7a
TGx 1485-1D(Check)	1443.7g	1929.2b	2243.7a
±SE		88.2	

Means followed by the same letters are not significantly different at P=0.05 using DMRT; SE = Standard error

**Table 3: Combined analysis for correlation matrix between growth and yield attributes against seed yield of some soybean genotypes as influenced by inoculation type during the 2015 and 2016 cropping seasons across environments**

	1	2	3	4	5	6	7	8	9	10
1	1									
2	0.564*	1								
3	0.621*	0.719*	1							
4	0.581*	0.603*	0.709*	1						
5	0.156*	0.298*	0.253*	0.186*	1					
6	0.599*	0.696*	0.752*	0.589*	0.240*	1				
7	0.599*	0.696*	0.752*	0.589*	0.240*	0.000*	1			
8	0.242*	0.335*	0.340*	0.307*	0.145*	0.333*	0.333*	1		
9	0.478*	0.424*	0.539*	0.393*	0.177*	0.455*	0.455*	0.199*	1	
10	0.591*	0.597*	0.696*	0.509*	0.234*	0.789*	0.789*	0.264*	0.889*	1

\*= Significant at 5%, ns= not significant, 1= Chlorophyll content, 2= Plant height, 3= Number of leaves, 4= Number of pods per plant, 5= Number of branches per plant, 6= Above ground biomass yield, 7= Total biomass yield, 8= Harvest index, 9= 100-seed weight, 10= Seed yield

**Table 3: Combined analysis for sensitivity and stability coefficients for seed yield from soybean genotypes across environments during the 2015 and 2016 cropping seasons**

Genotype	Mean	Sensitivity (b value)	Static Stability	Mean square Deviation
TGx 1989-53FN	1493	0.7377	62849	909
TGx 1989-45F	1631	0.7381	64383	3846
TGx 1989-75FN	1571	0.8235	79986	12118
TGx 1990-114FN	1539	0.8239	83799	4325
TGx 1990-110FN	1594	0.8509	91675	17353
TGx 1485-ID(CK)	1570	0.8553	98997	32982
TGx 1993-4FN	1564	0.9010	100316	19412
TGx 1989-68FN	1537	0.9180	100367	7392
TGx 1990-78F	1488	0.9270	102786	973
TGx 1989-42F	1568	0.9485	104917	3565
TGx 1987-62F(CK)	1585	0.9533	105135	1887
TGx 1835-10E(CK)	1567	0.9676	118586	22522
TGx 1990-95F	1607	0.9848	118601	61738
TGx 1989-40F	1577	1.0000	124557	4196
TGx 1990-40F	1592	1.0414	136271	426
TGx 1989-11F	1579	1.0881	139353	18149
TGx 1987-10F(CK)	1566	1.0900	142051	125
TGx 1990-52F	1587	1.0970	144824	2772
TGx 1448-2E(CK)	1596	1.1146	146514	8178
TGx 1990-55F	1632	1.1271	149189	7093
<b>Grand mean</b>	<b>1570</b>			

CK= Check



## REFERENCES

- Afolayan, S. O. and Braimoh, A. K. (1991). Effect of tillage operation on the yield of okra. National Horticultural Research Institute, Ibadan. Research Bulletin No. 10.
- Arslanoglu, F. and Aytac, S. (2010). Determination of stability and genotype  $\times$  environment interactions of some agronomic properties in the different soybean cultivars. *Bulgarian Journal of Agricultural Sciences*, 16:181-195.
- Asrat, A., Fistum, A., Fekadu, G. and Mulugeta, A. (2009). AMMI and SREG GGE biplot analysis for matching varieties onto soybean production environment in Ethiopia. *Journal of Scientific Research and Essay*, 4(11), 1322-1330.
- Baker, R. J. (1988). Tests for crossover genotype  $\times$  environment interactions. *Canadian Journal of Plant Science*, 68, 405-410
- Bellaloui, N., Hanks, J.E., Fisher, D.K. and Mengistu, A. (2009) Soybean seed composition is influenced by within-field variability in soil nutrients. *Crop Management*, doi:10.1094/CM-2009-1203-01-RS
- Coskan, A. and Dogan, K. (2011). Symbiotic Nitrogen Fixation in Soybean. *Soybean Physiology and Biochemistry*, Edited by Hany A. El-Shemy, ISBN 978-953-307-534-1.
- Cucolotto, M., Valeria, C. P., Deoclecio, D. G., Nelson S. F., Deoniso D. and Marcos K. K. (2007). Genotype  $\times$  environment interaction in soybean: evaluation through three methodologies. *Crop Breeding and Applied Biotechnology*, 7, 270-277.
- Egli, D. B. (1998). Seed biology and the yield of grain crops. CAB International, Oxford, 178.
- Faisal, G. A. (1986). Influence of sowing and harvesting, timing, seed position and storage on the quality of soybean. Thesis submitted to University of Khartoum in partial fulfilment of requirement for the degree of M. Sc. (agriculture). University of Khartoum.
- Fasoula, V. A. and Fasoula, D. A. (2002). Principles underlying genetic improvement for high yield and stable crop yield potential. *Field Crops Research*, 75: 191-209.
- Gebeyehu, S. and Assefa, H. (2003). Genotype  $\times$  environment interaction and stability analysis of seed in bean genotypes. *Africa Crop Science Journal*, 11: 1-7
- Haliloglu, H., Beyyavas, V., Cevheri, C. I., Boydak, E. and Yilmaz, A. (2007). Genetic variability of the main yield related characters in soybean. *International Journal of Agriculture and biology*, 8(6), 815-819
- Jinze, X. (2010). Tanzania soybean development strategy (tsds) 2010 to 2020.
- Kang M. S. (Ed.), *Quantitative genetics, genomics and plant breeding*, CABI
- Kang, M. S. (2002). Genotype-Environment interaction: Progress and prospects. In
- Karasu, A., Goksoy, T. A. and Turan, Z. M. (2002). Interrelationships of agronomical characteristics in soybean (*Glycine max*) grown in different environments. *International Journal of Agriculture and Biology*, 11, 85-88
- Kumudini, S., Hume, D. J. and Chu, G. (2001). Genetic improvements in short season soybean dry matter accumulation, partitioning and leaf area duration. *Crop Science*, 41: 391-398.
- Laswai, H. S., Mpagalile, J. J., Silayo, V. K. and Ballegu, W. R. (2005). Use of soybeans in food formulation in Tanzania. In: Myaka FA, Kirenga G, Malema B (eds) 2006. Proceedings of the First National Soybean Stakeholders Workshop, 10th-11th November 2005, Morogoro- Tanzania. Pp. 52-59.
- Maestri, D. M., Labuckas, D. O., Guzman, C. A. and Giorda, L. M. (1998). Correlation between seed size, protein and oil contents and fatty acid composition in soybean genotypes. *Grasas Aceites*, 49, 450-453.
- Malik, M. F. A., Qureshi, A. S., Ashraf, M. and Ghafoor, A. (2006). Genetic variability of the main yield related characters in soybean. *International Journal of Agriculture and Biology*, 8(6): 815-819



- Malik, M. F. A., Qureshi, A. S., Ashraf, M. and Ghafoor, A. (2006). Genetic variability of the main yield related characters in soybean. *International Journal of Agriculture and Biology*, 8(6): 815-819  
Publishing, Wallingford, U.K. pp. 221-243.
- Rajanna, M. P., Viswanatha, S. R., Kulkarni, R. S. and Ramesh, S. (2000). Correlation and path analysis in soybean. *Crop Research Hisar*, 20: 244-247
- SAS (Statistical Analytical Software) (2003). Version 9.1. SAS Institute Inc., Cary, NC.
- Wilcox, J. R. and Shibles, R. M. (2001). Interrelationships among seed quality attributes in Soybean. *Crop Sciences*. 41(1):11-14.



## MARKET INTEGRATION OF SESAME SEEDS IN SOUTH ASIA

\*Sadiq, M.S<sup>1</sup>., Singh, I.P<sup>2</sup>., Lawal, M<sup>3</sup>. and Muhammad, H<sup>4</sup>.

<sup>1</sup>Department of Agricultural Economics, FUT, Minna, Nigeria

<sup>2</sup>Department of Agricultural Economics, SKRAU, Bikaner, India

<sup>3</sup>Department of Agricultural Education, Federal College of Education, Katsina, Nigeria

<sup>4</sup>Department of Agricultural Economics, BUK, Kano, Nigeria

Author correspondence address: Sadiq, Mohammed Sanusi, Department of Agricultural Economics, FUT, P.M.B 65, Minna, Niger State, Nigeria

Email: [sadiqsanusi30@gmail.com](mailto:sadiqsanusi30@gmail.com) (+2347037690123)

### ABSTRACT

The present research empirically determined the spatial price linkage of South-Asia exporting sesame seeds markets with the importing market using annual producer's price sourced from FAO database. The analytical techniques used to achieve the stated objective were descriptive and inferential statistics. The empirical findings showed that the selected markets were not autarkic as price information was efficiently transmitted across the geographical far apart markets. Furthermore, the traders effectively responded to price innovation or shock in order to maintain price equilibrium in their respective markets. Evidence showed that hike in low-quality prices would be relatively less reflected in Bangladesh and Pakistan markets. However, trade in sesame seeds is found useful as there is high industrial demand for the commodity by the importing economies. Thus, the study recommended network design for sesame producer's markets across the region at an almost equal distance from each other to enhance integration and better price communication among the exporting and importing economies.

**Keywords:** Price; Integration; Market; Sesame; South-Asia

### INTRODUCTION

Efficient functioning of markets is an essential prerequisite for sound marketing systems that provide remunerative prices to the farmers/producers as well as provide goods at reasonable prices to the innumerable consumers [1]. One of the common indicators of an efficient functioning of markets is the existence of a high degree of integration between them [2]. The existence of integration in the markets influences the conduct of the firms in the markets and consequently the marketing efficiency [3].

The analysis of price movement of a commodity in the corresponding and linked markets helps in judging the extent of efficiency of the marketing system in the region for the selected crops [1]. The ultimate objective of planners and policymakers in the field of agriculture marketing is to develop efficient markets for the agricultural product produced by the farmers of a region. If farmers can get remunerative price for their produced commodity, they will have the tempo of incentive for increased production.

The present structure of the agricultural marketing system prevailing in South-Asia may not be conducive for improving marketing efficiency of sesame seeds. Poor marketing infrastructures and paucity of information dissemination act as barriers for better market integration of sesame product in Asia. Price signals transmitted by non-integrated markets would mislead producers' on marketing

decisions, thus resulting in inefficient commodity movement.

Considering the importance of the information evolving out of market integration studies, an attempt was made to discern the status of market integration among the South-Asia sesame seed exporting economies and the importing global economy. The broad objective of the research was to determine the market integration of sesame exporting and importing economies, while the specific objectives were to determine the extent and degree of spatial price integration; to predict the future sesame seed prices; and, to determine price volatility of sesame seeds in the selected markets.

### RESEARCH METHODOLOGY

Annual sesame producer's price series data for exporting economies: India (ISM), Pakistan (PSM) and Bangladesh (BSM); and importing economy viz. China (CSM) spanning from 1991 to 2015 sourced from FAO database were used. The data analysis was performed using descriptive and inferential statistics. The first and second objectives were achieved using the unit root tests, Johansen cointegration test and Vector Autoregressive model (VECM); and, the last objective was achieved using the GARCH model.

#### *Empirical Model*

#### *Augmented Dickey-Fuller test*

Following Sadiq *et al.* [4] the autoregressive formulation of the ADF test with a trend term is given below:

$$\Delta P_t = \alpha + P_{t-1} + \sum_{j=2}^{it} \beta_j \Delta P_{it-j} + \varepsilon_t \quad \dots\dots\dots (1)$$

Where,  $P_{it}$  is the price in market  $i$  at the time  $t$ ,  $\alpha$  and  $\Delta P_{it}$  ( $P_{it} - P_{t-1}$ ) is the intercept or trend term.

**Johansen's co-integration test**

Following Johansen [5] the multivariate formulation is specified below:

$$P_t = A_1 P_{t-1} + \varepsilon_t \quad \dots\dots\dots (2)$$

So that

$$\Delta P_t = A_1 P_{t-1} - P_{t-1} + \varepsilon_t \quad \dots\dots\dots (3)$$

$$P_t = (A_1 - 1)P_{t-1} + \varepsilon_t$$

$$\Delta P_t = \prod P_{t-1} + \varepsilon_t$$

Where,  $P_t$  and  $\varepsilon_t$  are  $(n \times 1)$  vectors;  $A_t$  is an  $(n \times n)$  matrix of parameters;  $I$  is an  $(n \times n)$  identity matrix, and  $\prod$  is the  $(A_1 - 1)$  matrix.

Using the estimates of the characteristic roots, the tests for the number of characteristic roots that are insignificantly different from unity were conducted using the following statistics:

$$\lambda_{trace} = -T \sum_{i=r+1}^n \ln(1 - \lambda_i) \quad \dots\dots\dots (4)$$

$$\lambda_{max} = -T \ln(1 - \lambda_i + 1) \quad \dots\dots\dots (5)$$

Where,  $\lambda_i$  denotes the estimated values of the characteristic roots (Eigen-values) obtained from the estimated  $\prod$  matrix, and  $T$  is the number of usable observations.

**Granger causality test**

Following Granger [6] the model used to check whether market  $P_1$  Granger causes market  $P_2$  or vice-versa is given below:

$$P_t = \alpha + \sum_{i=1}^n (\phi P_{1t-i} + \delta_i P_{2t-i}) + \varepsilon_i \quad \dots\dots\dots (7)$$

A simple test of the joint significance of  $\delta_i$  was used to check the Granger causality i.e.

$$H_0 := \delta_1 = \delta_2 = \dots\dots\dots \delta_n = 0.$$

**Vector error correction model (VECM)**

The VECM explains the difference in  $y_t$  and  $y_{t-1}$  (i.e.  $\Delta y_t$ ) and it is shown below [7, 8]:

$$\Delta y_t = \alpha + \mu(y_{t-1} - \beta_{xt-1}) + \sum_{i=0}^{i=t} \delta_i \Delta x_{t-1} + \sum_{i=1}^{i=t} \gamma_i \Delta y_{t-1} \quad \dots\dots\dots (8)$$

It includes the lagged differences in both  $x$  and  $y$ , which have a more immediate impact on the value of  $\Delta y_t$ .

**Impulse response functions**

The generalized impulse response function (GIRF) in the case of an arbitrary current shock ( $\delta$ ) and history ( $\omega_{t-1}$ ) is specified below [9, 10]:

$$GIRF_Y(h, \delta, \omega_{t-1}) = E[Y_t + h | \delta, \omega_{t-1}] - E[Y_{t-1} | \omega_{t-1}] \quad \dots\dots\dots (9)$$

**Forecasting accuracy**

For measuring the accuracy in fitted time series model, mean absolute prediction error (MAPE), relative mean square prediction error (RMSPE), relative mean absolute prediction error (RMAPE) [11], Theil's U statistic and  $R^2$  were computed using the following formulae:

$$MAPE = 1/T \sum_{i=1}^5 (A_{t-1} - F_{t-1}) \quad \dots\dots\dots (10)$$

$$RMPSE = 1/T \sum_{i=1}^5 (A_{t-1} - F_{t-1})^2 / A_{t-1} \dots\dots\dots (11)$$

$$RMAPE = 1/T \sum_{i=1}^5 (A_{t-1} - F_{t-1}) / A_{t-1} \times 100 \quad \dots\dots\dots (12)$$

$$U = \sqrt{\frac{\sum_{t=1}^{n-1} (\hat{Y}_{t+1} - Y_{t+1})^2}{Y_t}} \quad \dots\dots\dots (13)$$

$$R^2 = 1 - \frac{\sum_{i=1}^n (A_{ti} - F_{ti})}{\sum_{i=1}^n (A_{ti})} \quad \dots\dots\dots (14)$$

Where,  $R^2$  = coefficient of multiple determination,  $A_t$  = Actual value;  $F_t$  = Future value, and T = time period

**GARCH model**

The representation of the GARCH ( $p, q$ ) is given as:

$$Y_t = \alpha + \beta_1 Y_{t-1} + \beta_2 Y_{t-2} + \varepsilon_i \quad \dots\dots\dots (15)$$

(Autoregressive process) And the variance of random error is:

$$\sigma_t^2 = \lambda_0 + \lambda_1 \mu_{t-1}^2 + \lambda_2 \sigma_{t-1}^2 \quad \dots\dots\dots (16)$$

$$\sigma_t^2 = \omega + \sum_{i=1}^p \beta_i \sigma_{t-i}^2 + \sum_{j=1}^q \alpha_j \varepsilon_{t-i}^2$$

$$\dots\dots\dots (17)$$



Where  $Y_t$  is the price in the  $i^{th}$  period of the  $i^{th}$  market,  $p$  is the order of the GARCH term and  $q$  is the order of the ARCH term. The sum of ARCH and GARCH ( $\alpha + \beta$ ) gives the degree of persistence of volatility in the series. The closer is the sum to 1; the greater is the tendency of volatility to persist for a longer time. If the sum exceeds 1, it is indicative of an explosive series with a tendency to meander away from the mean value.

## RESULTS AND DISCUSSION

### Summary Statistics of the Selected Sesame Seeds Market

The results showed the sesame seeds prices of the exporting economies to be stable while that of the importing economy to be unstable. Furthermore, the exporting markets with lowest and highest prices were Bangladesh and Pakistan respectively. For the

overall, the importing economy (China) had the highest sesame seeds price among the selected markets. The prices of sesame seeds for all the selected markets were positively skewed and this is reasonable since the product inventories cannot be negative, which places a positive skewness bias in the data. Floor prices tend to introduce positive skewness while ceiling prices tend to promote negative skewness. Therefore, from a practical perspective, the presence of positive skewness can help policy design in that positive price asymmetry implies that traders can be quite confident in establishing a minimum price level. Excess kurtosis was not observed as shown by the tails of the distribution which were not thicker than the normal (kurtosis coefficient of less than 3), thus indicating that none of the selected markets exhibited extreme price values.

**Table 1: Summary statistics of sesame prices for the selected markets**

Markets	Mean	Min	Max	SD	CV	Skewness	Kurtosis
BSM	387.20	223.60	633.70	129.80	0.33521	0.72011	-0.84380
ISM	557.72	402.20	782.10	113.15	0.20288	0.45002	-0.90771
PSM	660.56	488.90	919.60	91.168	0.13802	0.98178	1.8386
CSM	1108.70	311.40	2584.80	745.81	0.67271	0.87499	-0.72643

### Lag Selection Criteria

The results showed that the appropriate length of lag for truncation was lag four as shown by the selection criteria viz. Akaike information criterion (AIC), Schwarz Bayesian information criterion (SBIC) and

Hannan-Quinn information criterion (HQC) (Table 2). The inclusion of the chosen lag length will make the model residuals to be pure white noise and also give parsimonious interpretable results.

**Table 2: Lag selection criteria**

Lag(s)	AIC	BIC	HQC
1	47.70	48.49	47.87
2	46.46	48.05	46.81
3	45.95	48.33	46.46
4	40.85*	44.04*	41.54*

Note: \* denote lag length selected by a criterion

### Unit Root Tests

The ADF unit root test showed that all the price series were stationary at level as indicated by their respective tau-statistics which were not different from zero at 5% probability level. But after first difference, all the price series became stationary as indicated by their respective tau-statistics which were different from zero at 5% risk level. Furthermore, the ADF-GLS unit root test indicated the validity and

robustness of the ADF tau-estimates for the price series as evidenced by their respective tau-statistics which were greater and lower than the t-critical value at level and first difference respectively. Therefore, it can be inferred that the price series are integrated of order one i.e. I(1). With the proof that all the price series are integrated of order one, the multivariate cointegration test was applied to examine the possibility of long-run association (Table 3).

**Table 3: ADF unit root test**

Market	Stage	ADF		ADF-GLS	
		$\tau - stat$	p-value	$\tau - stat$	t - critical
BSM	Level	-0.15079	0.9325	-1.32995	-3.19
	$1^{st} \Delta$	-4.09892**	0.0046	-4.44421**	-3.19
ISM	Level	-0.30601	0.9218	-0.58510	0.4642

	$1^{st} \Delta$	-6.01669**	1.09e-07	-4.24070**	2.35e-05
PSM	Level	-2.85899	0.1761	-3.10334	-3.19
	$1^{st} \Delta$	-3.73597**	0.0200	-4.72773**	-3.19
CSM	Level	-1.21852	0.9059	-1.17545	-3.19
	$1^{st} \Delta$	-6.79163**	6.31e-05	-7.10636**	-3.19

Note:  $\Delta$  and \*\* indicate first difference and rejection of null hypothesis at 5% probability level respectively.

### Extent of Price Integration

Empirical evidence showed the existence of effective and efficient price transmission as indicated by cointegration of the vectors at rank for both the trace and max test statistics (Table 4a). This means that prices of sesame among the selected markets move together in the long-run i.e. there is a perfect flow of price information within the horizon of the exporting and importing economies. Furthermore, it implies that the four selected sesame markets shared one stochastic trend with none existence of an independent market in the region. Therefore, it can be inferred that the law of one price (LOP) hold between these markets i.e. the price differential between two markets is equal to the cost of transfer. In addition, the sesame markets in the region are efficiently

integrated as the collusive activities of the oligopolistic intermediaries, monopolistic buyers behavior in price fixing on the auction floor and the local powers exercised by the traders are been minimized due to proper market infrastructure, ICT, articulated agricultural export measures and efficient and functional commodity exchange markets in the region.

The presence of one stochastic for all the four selected markets implies the likelihood of pair-wise co-integration of the prices. The pair-wise co-integration results showed that LOP did not hold between the market pairs (Table 4b). However, there is the possibility of these market pairs to be integrated if considered at moderate to high lag levels.

**Table 4a: Multivariate co-integration result**

$H_0$	$H_1$	Eigen value	Trace test	P-value	Lmax test	P-value
$r = 0$	$r \geq 1$	0.99997	313.50	0.0000	218.30	0.0000
$r \leq 1$	$r \geq 2$	0.93678	95.199	0.0000	57.983	0.0000
$r \leq 2$	$r \geq 3$	0.78262	37.216	0.0001	32.049	0.0000
$r \leq 3$	$r = 4$	0.21814	5.1677**	0.2752	5.1677**	0.2746

Note: \*\*denotes rejection of the null hypothesis at 5 percent level of significance

**Table 4b: Pair-wise co-integration result**

Markets	$H_0$	$H_1$	Trace test	P-value	Lmax test	P-value	CE
BSM-ISM	$r = 0$	$r \geq 1$	2.9017	0.8472	2.8998	0.7963	None
	$r \leq 1$	$r \geq 2$	0.0019	0.9836	0.0019	0.9812	
BSM-PSM	$r = 0$	$r \geq 1$	3.0584	0.8282	2.4209	0.8612	None
	$r \leq 1$	$r \geq 2$	0.6375	0.4886	0.6375	0.4824	
BSM-CSM	$r = 0$	$r \geq 1$	6.5402	0.3745	5.6479	0.3993	None
	$r \leq 1$	$r \geq 2$	0.8923	0.4004	0.8923	0.3962	
ISM-PSM	$r = 0$	$r \geq 1$	3.6392	0.7527	3.6232	0.6884	None
	$r \leq 1$	$r \geq 2$	0.0161	0.9395	0.0161	0.9339	
ISM-CSM	$r = 0$	$r \geq 1$	2.3175	0.9101	2.1996	0.8882	None
	$r \leq 1$	$r \geq 2$	0.1179	0.7989	0.1179	0.7897	
PSM-CSM	$r = 0$	$r \geq 1$	2.2576	0.9158	1.5010	0.9561	None
	$r \leq 1$	$r \geq 2$	0.7567	0.4444	0.7567	0.4392	

Note: \*\*denotes rejection of the null hypothesis at 5 percent level of significance

CE- Cointegration equation

### Degree of Market Integration

A cursory review of the results showed that a price shocks in all the selected markets with the exception of India market that induces price deviations from

their respective equilibrium level as indicated by the significance of their attractor coefficients would induce the traders in these markets to respond to the shocks in a way that the prices would converge

toward their equilibrium value (Table 5). The speed at which BSM, PSM and CSM will correct its previous deviation from the equilibrium due to short-run shocks would be 12.4%, 47.8% and 64.1% respectively; and the approximate time required to re-establish equilibrium would be 1.8, 5.7 and 7.7 months respectively. The flow of information is high in BSM, moderate in PSM and low in the importing market. Hence, BSM is more efficient than PSM in terms of reaction to price news, while the PSM, in turn, is more efficient than CSM in reacting to price news. Based on the foregone discussion, it can be suggested that even though the markets are integrated, there is disequilibrium in the short-run due to the price adjustments across the markets which did not happen instantaneously or simultaneously. Furthermore, there are delays in the short-run price transmission of these markets as their respective coefficients of the lagged price differences were different from zero at 10% degree of freedom. However, further changes in the subsequent periods (lagged 3) for Indian sesame price would help it to achieve equilibrium in the long-run.

#### Direction of Price Formation

According to Ghafoor *et al.*[12], the direction of price formation between the market pair and related spatial arbitrage, i.e. physical movement of the commodity to adjust the price differences is shown by Granger causality. A perusal of the Table showed market pair *viz.* BSM-CSM to have bidirectional causality; market pairs' *viz.* BSM-ISM, BSM-PSM, CSM-ISM and CSM-PSM to have unilateral causalities while market pair *viz.* ISM-PSM did not have a causal relationship as indicated by the f-

statistics for the first two former which were different from zero at 5% probability level and the later whose f-statistics were not different from zero at 5% probability level respectively (Table 6). For the market pair with bidirectional causality, it implies that the former market granger cause price formation in the latter market, likewise the latter market granger cause price formation in the former market i.e. there exist feed-forward and feed-backward relationship between the markets in pair in sesame price formation. In the case of market pairs with unilateral causality, it means that only the lagged of the former in the pair contain useful information in predicting the future price of the latter. However, for the market pairs with none causality, it means that neither the former nor the latter in the pair Granger cause price formation in each direction. Therefore, it can be inferred that the market pair BSM-CSM exhibited strong endogeneity but weak exogeneity in pair with other selected markets. However, strong exogeneity was observed between the price pair of ISM-PSM, justifying the effect of external influence in determining the direction of price formation in these markets. The dominant influence of BSM in the South-Asia region may be attributed to its quick emergence with an adequate supply of sesame product in the global sesame markets; while the dominant role of CSM may be due to its importing position to meet its high industrial demand. However, the weak influence of ISM and PSM may be due to the possibility of exploring other fast-emerging importing economies in the world with high industrial demand for sesame commodity.

**Table 6: Horizontal pair-wise Granger causality test results**

Null hypothesis	F-stat	P < 0.05	Granger cause	Direction
<b>BSM ↔ ISM</b>	87.53**	0.0019	Yes	Unidirectional
	2.835	0.2092	No	
<b>BSM ↔ PSM</b>	78.81**	0.0023	Yes	Unidirectional
	7.822	0.0613	No	
<b>BSM ↔ CSM</b>	17.87**	0.0197	Yes	Bidirectional
	109.68**	0.0014	Yes	
<b>ISM ↔ PSM</b>	3.802	0.1507	No	None
	5.194	0.1036	No	
<b>ISM ↔ CSM</b>	1.948	0.3052	No	Unidirectional
	28.19**	0.0103	Yes	
<b>PSM ↔ CSM</b>	3.684	0.1563	No	Unidirectional
	64.84**	0.0030	Yes	
<b>BSM → ALL</b>	61.31**	0.0030	Yes	Multidirectional
<b>ISM → ALL</b>	9.208**	0.0466	Yes	Multidirectional
<b>PSM → ALL</b>	5.424	0.0950	No	None



<b>CSM → ALL</b>	68.70**	0.0025	Yes	<b>Multidirectional</b>
------------------	---------	--------	-----	-------------------------

Note: \*\* denotes rejection of the  $H_0$  at 5% level of significance

NS: Non-significant

→ ← means forward and backward directions respectively

### Effect of Bad-news on the Future Prices of Sesame

The relative strength of causality effects beyond the selected time span cannot be determined by Granger causality test. In such circumstances, causality test is inappropriate because this test cannot indicate how much feedback exists from one variable to the other beyond the selected sample period [9]. The best way to interpret the implications of the model for patterns of price transmission, causality and adjustment are to consider the time paths of prices after exogenous shocks i.e. impulse responses [13].

If there is cointegration, the estimation of impulse response function (IRF) is inconsistent at long horizon using the unrestricted VAR, so the stable impulse response function was estimated from the restricted VAR. The integration of order one variables modeled in a co-integrating VECM are not mean reverting, and the unit moduli in the companion matrix imply that the effect of some bad-news will not die-out over time. The IRF results diagrammatically depicted in Figure 1 revealed how and to what extent an innovation (bad-news) in one market affects the current and future prices in all the integrated markets in the region over a time span of 10 years.

The graph indicated that unexpected shocks that are local to Bangladesh and Pakistan sesame prices would have transitory effects on the sesame prices of their respective own markets and that of India and

China, while bad-news that are local to India and China markets would not die-out overtime in their respective markets, against each other's market and Bangladesh market, but will die-out overtime in Pakistan market.

Having confirmed that the speeds as well as magnitude of shocks given to Bangladesh and Pakistan markets are relatively less transmitted to other markets, it can be inferred that these markets are trend followers and not trendsetters and the reason for their subservient role could be attributed to their new emergence in the global importing sesame seeds market. In addition, they would not play a significant role in the sesame exporting economies of south-Asia.

A positive standard deviation shock in the sesame prices would force the consumers to shift from low-quality sesame product to high-quality sesame, thus the hike in low-quality prices would be relatively less reflected in the Bangladesh and Pakistan markets. Therefore, quality improvement of sesame product will have meaningful implication that would be reflected in the Bangladesh and Pakistan markets. However, the reason for comparative competency of India market among the sesame exporting economies may be due to its long-time trade in sesame product in the international sesame market and high-quality product standard.

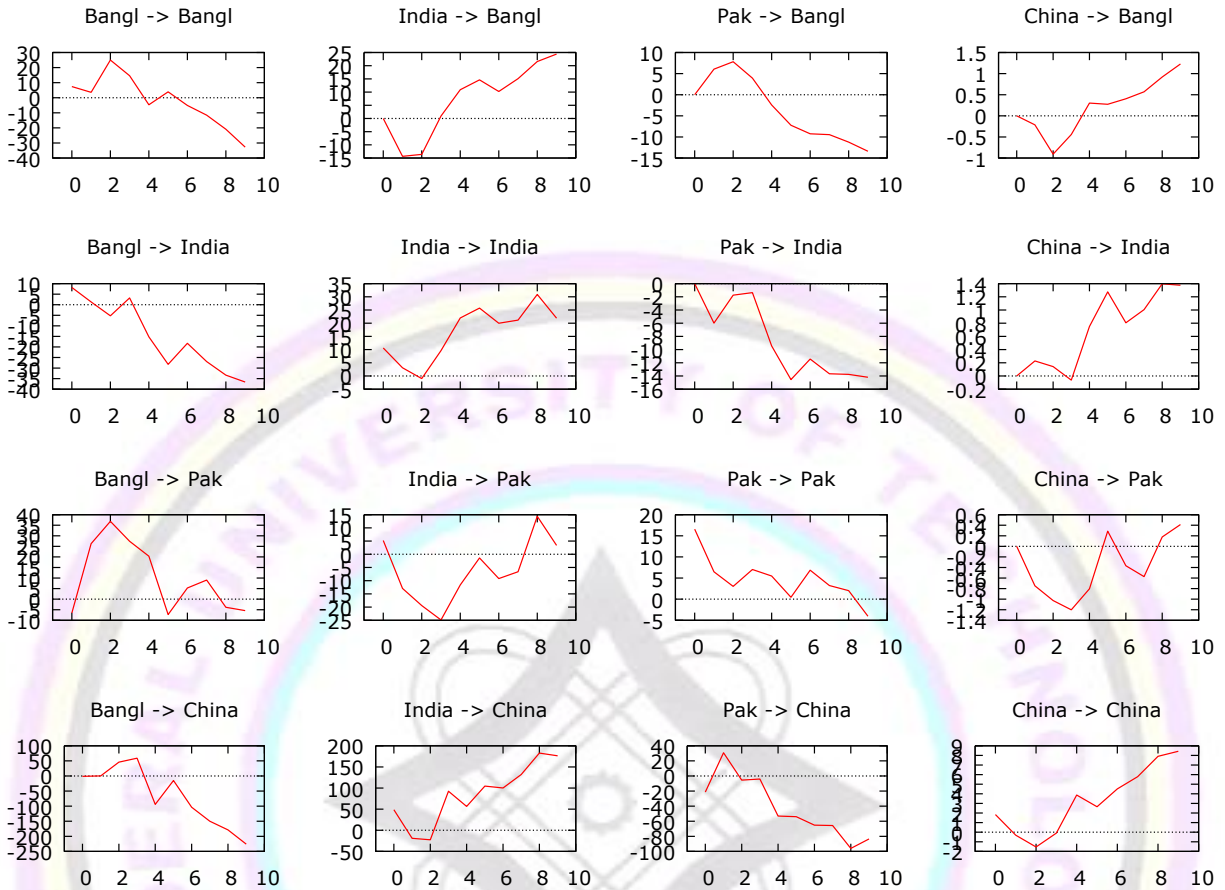


Figure 1: Impulse response of sesame markets to shocks

### Price Forecast of Sesame

#### Diagnostic checking and validation

The VECM was found to be the appropriate in forecasting the producer's prices of the selected markets as indicated by the diagnostic test results which exonerated the disturbance variables from the problem of autocorrelation and auto-covariance as evidenced by the Ljung-Box Q-stats and Langrage multiplier tests respectively which were not different from zero at 10% risk level (Table 5). Therefore, the absence of random error means that the producer's price of sesame is predictable, and it will be good for policy making, consumer decision and consumption pattern.

#### Validation (*Ex-post* prediction power)

Though price movement prediction is in contrast to the efficient marketing theory which postulated that

for a market to operate efficiently, prices should be unpredictable, in that if they are stationary and predictable they will attract investors and their active participation will ultimately lead to the cancellation of the prediction. However, this deductive (theory) idea has little empirical extent as inductive (facts) knowledge showed that prediction of prices is very important in measuring market efficiency except that the prediction should not be too long.

One-step-ahead forecast of the prices along with their corresponding standard errors using naïve approach for the period 2011 to 2015 (total 5 data points) in respect of the VECM fitted model was computed to determine the predictive power of the estimated equation (Table 7a). This was done to examine how closely they could track the path of the actual observation.

Table 7a: One step ahead forecast of prices

Period	BSM		ISM		PSM		CSM	
	Actual	Forecast	Actual	Forecast	Actual	Forecast	Actual	Forecast
2011	544.4	543.2	782.1	786.6	714.4	714.2	1764.3	1795.1
2012	556.7	556.1	660.1	663	659.7	653.6	2122.8	2150.4
2013	574.8	574.7	682.4	680.8	675	673.3	2388.7	2382.7

2014	617.1	615.3	696.9	691	716.1	724.6	2405	2376.9
2015	633.7	640.6	689.3	684.3	705.3	709.7	2412.9	2333.3

The price forecasting ability of the producers' market prices of sesame was measured using the mean absolute prediction error (MAPE), root mean square error (RMSE), Theil's inequality coefficient (U) and the relative mean absolute prediction error (RMAPE) (Table 7b). The results indicated the accuracy of the

forecasted price as shown by the respective market RMAPE and U which were less than 10% and less than 1 respectively. Therefore, these relatively low values indicate the consistency of the forecasted prices with the actual prices.

**Table 7b: Validation of models**

Market	R <sup>2</sup>	MAPE	RMSPE	RMAPE (%)	Theil's U
BSM	0.999	0.88	0.016209	0.1344	0.0177
ISM	0.998	1.92	0.020542	0.273424	0.0056
PSM	0.998	1.02	0.037806	0.12686	0.0266
CSM	0.995	17.22	0.665638	0.683669	0.0261

Source: Authors computation, 2018

### Price Forecast of sesame seed in the selected markets

Shown in Table 7c and Figure 2 are the computed one step ahead out of the sample forecast of the producer's sesame prices (dollars per ton) spanning from 2016-2025 for the selected markets. The short span prediction was made in order not to affect market efficiency as long prediction will attract investors which will result in the breakdown of the forecasted price.

A cursory review of the results showed that the predicted sesame seed price of Bangladesh would witness steep decline till it reaches an ebb in the year 2021, and thereafter exhibit an oscillating trend with upward and downward swings. The forecasted sesame price of India would exhibit an oscillating trend with the highest price peaking period being 2018 and the lowest ebbing period being 2020. The sesame seed price of Pakistan will witness a steep increasing trend and will peak in the year 2019 and thereafter a steep decline ebbing in the year 2021.

Furthermore, the price trend of Pakistan sesame seed will exhibit an oscillating trend with the periods 2022 to 2023 having upward swing, while 2024 to 2025 will witness downward swing. The predicted price of China sesame seeds will exhibit a declining trend till it ebb at the year 2019, thereafter a flatten like trend though there will be slight rise from the year 2020 to 2022 and then slight fall in the year 2023 to 2024, and then a slight rise at the end of the forecasted period. Therefore, it can be inferred that across the markets, prices of sesame seeds in the future will not be fairly remunerative for the producers which may be due to a collusive effect of the oligopolistic intermediaries in the marketing chain of sesame in the region.

Therefore, there is need to strengthen the production and marketing infrastructure to ensure allocative efficiency in the marketing of sesame in the region so that neither the producers nor the middlemen nay the consumers would be better-off nor worse-off.

**Table 7c: Out of sample price forecast for the selected sesame markets (\$ per ton)**

Year	BSM			ISM		
	Forecast	LCL	UCL	Forecast	LCL	UCL
2016	581.50	566.90	596.00	596.90	569.70	622.20
2017	573.40	538.80	608.00	601.90	572.40	631.40
2018	558.50	491.10	625.90	643.80	612.30	675.30
2019	484.20	410.50	557.80	591.30	554.00	628.70
2020	425.80	348.40	503.20	533.20	466.20	600.20
2021	407.30	323.20	491.40	545.20	440.80	649.70
2022	451.00	362.10	539.90	583.80	464.60	703.10
2023	452.50	354.40	550.70	615.10	475.60	754.60
2024	415.00	298.40	531.50	565.10	397.40	732.90
2025	422.60	278.70	566.40	595.40	405.90	784.90
Year	PSM			CSM		
	Forecast	LCL	UCL	Forecast	LCL	UCL
2016	448.70	412.30	485.10	2102.70	1998.50	2206.90
2017	382.80	313.60	452.00	1800.70	1674.70	1926.70



2018	510.10	402.90	617.30	1924.60	1763.20	2086.00
2019	630.20	500.00	760.40	1312.90	1043.90	1581.80
2020	589.10	450.60	727.60	1441.80	1081.90	1801.80
2021	529.20	389.90	668.40	1447.50	1018.90	1876.10
2022	544.80	403.40	686.30	1494.30	965.40	2023.20
2023	595.70	452.40	739.00	1418.40	747.70	2089.00
2024	485.80	339.50	632.10	1297.40	439.20	2155.60
2025	478.20	331.20	625.20	1334.10	295.20	2372.90

### Price Volatility of Sesame seeds

The price series of all the selected markets met the pre-condition for volatility test as their respective residuals showed presences of cluster volatility and Arch effects. A cursory review of the results showed that persistence volatility existed in the prices of all the selected sesame markets as indicated by their respective estimated sum of the ARCH and GARCH terms which were close to “one” (Table 8). The implication is that the volatility of sesame prices in each of the selected markets has the tendency to persist for a while but will not meander away from the mean value. The perusal of the Table showed that the current volatility in the Bangladesh market and the importing (China) economy was triggered by information about previous price arbitrage of sesame seeds in their respective markets. However, it was observed that the family shock had no effect on current price volatility of sesame seeds in India and

Pakistan markets, implying the possibility of outside shocks been responsible for the current volatility in these markets. Based on these outcomes, it is vividly clear that sesame trade is useful and the reason may be attributed to high industrial demand for the product by the importing countries in the global sesame seed markets.

The autocorrelation tests showed that the residuals of the models were none correlated as indicated by their respective Q-stats which were not different from zero at 10% degree of freedom. However, with the exception of the volatility model for Indian sesame seed price all the residuals of the selected price series were not normally skewed as indicated by their respective Chi<sup>2</sup> which were different from zero at 10% risk level. Though, non-normality is not considered a serious problem as data in most cases are not normally skewed.

**Table 8: Price volatility of sesame seeds in the selected markets**

Items	BSM	ISM	PSM	CSM
<b>Mean equation</b>				
<b>Arch Eff.</b>	13.058{ 0.0003}***	4.762{ 0.0290}**	4.239{0.013}**	6.838{ 0.0089}***
<b>Variance equation</b>				
Alpha (1)	0.964(0.257)[ 3.73]***	0.884(14.2)[0.06] <sup>NS</sup>	0.500(2.57)[ 0.194] <sup>NS</sup>	0.10(0.044)[ 2.25]**
Beta (1)	1.0e-11(0.24)[4.2e-11] <sup>NS</sup>	1.197(18.5)[6.4e-12] <sup>NS</sup>	3.5e-11(4.06)[8.7e-12] <sup>NS</sup>	5.0e-11(0.35)[1.4e-10] <sup>NS</sup>
<b>α + β</b>	0.96	0.88	0.50	0.10
GARCH fit	1,1	1,1	1,1	1,1
<b>Normality</b>	9.56{ 0.008}***	3.20{ 0.201} <sup>NS</sup>	6.39{ 0.0408}**	15.5{0.0004}***
<b>Autocor.</b>	0.286{0.59} <sup>NS</sup>	1.277{0.53} <sup>NS</sup>	1.821{0.61} <sup>NS</sup>	2.59{0.63} <sup>NS</sup>

Note: \*\*\* \*\* \* implies significance at 1%, 5% and 10% respectively

NS: Non-significant; and values in ( ); [ ] and { } are standard errors, t-statistics and probability values

### CONCLUSION AND RECOMMENDATION

The empirical evidence showed that the LOP hold between the markets inspite of their spatiality, and the traders in almost all the selected markets respond to price bad-news to maintain an equilibrium values. In addition, a positive standard deviation shock on the low-quality sesame prices of Bangladesh and Pakistan would force buyers to shift to Indian sesame product of high-quality. However, findings showed the trade of sesame seeds to be useful due to high industrial demand for the product by the importing countries in the global sesame seed markets. Therefore, the study recommended that the network

of sesame producer’s markets should be well-designed in order to maintain an equal distance from each other as it will not only boost direct inter-market competition but will control the massive marketing margins of sesame seeds product. Also, the product can be transported to the deficit importing areas, thus benefiting both the producers and the industrial consumers.

### REFERENCES

1. SINGH, N.(2014).A study of integration of markets for onion and potato in South Gujarat. *International Research*

- Journal of Agricultural Economics and Statistics*, **5(2)**:241-244
2. WANI, M.H., PAUL, R.K., BAZAZ, N.H. AND MANZOOR, M.(2015).Market integration and price forecasting of Apple in India. *Indian Journal of Agricultural Economics*, **70(2)**:169-181
  3. PRAVEEN, K.V. AND INBASEKAR, K.(2015).Integration of agricultural commodity markets in India. *International Journal of Social Sciences*, **4(1)**:51-56.
  4. SADIQ, M S., SINGH, I.P., AMINU, S. AND GREMA, I. J.(2017).Volatility and price discovery of palm oil in international markets under different trade regime. *Journal of Agricultural Economics, Environment and Social Sciences*, **3(1)**: 33–50
  5. JOHANSEN, S.(1988).Statistical analysis of co-integration vectors. *Journal of Economic Dynamics and Control*, **12(2-3)**:231-254
  6. GRANGER, C.W.J.(1969).Investigating causal relations by econometric models and cross-spectral methods. *Econometrica: Journal of the Econometric Society*, **37(1)**:424-438
  7. SADIQ, M S., SINGH, I.P., SULEIMAN, AMINU, UMAR, S.M., GREMA, I.J., USMAN, B.I., ISAH, M.A. AND LAWAL, A. T (2016a).Extent, pattern and degree of integration among some selected cocoa markets in West Africa: An innovative information delivery system. *Journal of Progressive Agriculture*, **7(2)**: 22-39
  8. SADIQ, M.S., SINGH, I.P., SULEIMAN AMINU, UMAR, S.M., GREMA, I.J., USMAN, B.I., ISAH, M.A. AND LAWAL, A.T.(2016b).Price transmission, volatility and discovery of gram in some selected markets in Rajasthan State, India. *International Journal of Environment, Agriculture and Biotechnology*, **1(1)**:74-89.
  9. RAHMAN, M.M. AND SHAHBAZ, M.(2013).Do imports and foreign capital inflows lead economic growth? cointegration and causality analysis in Pakistan. *South Asia Economic Journal*, **14(1)**: 59-81.
  10. BEAG, F.A. AND SINGLA, N.(2014).Cointegration, causality and impulse response analysis in major Apple markets of India. *Agricultural Economics Research Review*, **27(2)**:289-298.
  11. PAUL, R.K.(2014).Forecasting wholesale price of pigeon pea using long memory time-series models. *Agricultural Economics Research Review*, **27(2)**: 167-176.
  12. GHAFOR, A., MUSTAFA, K., MUSHTAQ, K. AND ABEDULLA (2009).Cointegration and causality: An application to major mango markets in Pakistan. *Lahore Journal of Economics*, **14(1)**:85-113.
  13. VAVRA, P. AND GOODWIN, B.K.(2005).Analysis of Price Transmission along the Food Chain. OECD Food, Agriculture and Fisheries Working Paper 3 OECD Publishing, France.

**Table 5: Multivariate VECM results**

Variable	$\Delta$ BSM	$\Delta$ ISM	$\Delta$ PSM	$\Delta$ CSM	Influencing
$\Delta$ BSM <sub>t-1</sub>	1.929(0.262)[7.34]***	0.284(0.474)[0.60] <sup>NS</sup>	-2.213(0.657)[3.36]**	9.863(1.881)[5.24]***	<b>3</b>
$\Delta$ BSM <sub>t-2</sub>	1.125(0.214)[5.25]***	-0.162(0.386)[0.42] <sup>NS</sup>	-1.632(0.536)[3.04]**	2.973(1.534)[1.93] <sup>NS</sup>	<b>2</b>
$\Delta$ BSM <sub>t-3</sub>	0.227(0.172)[1.31] <sup>NS</sup>	0.182(0.312)[0.58] <sup>NS</sup>	-2.164(0.432)[5.00]***	2.817(1.238)[2.27]*	<b>2</b>
$\Delta$ ISM <sub>t-1</sub>	-2.146(0.290)[7.39]***	-0.922(0.524)[1.75] <sup>NS</sup>	-4.274(0.726)[5.88]***	-6.829(2.079)[3.28]**	<b>3</b>
$\Delta$ ISM <sub>t-2</sub>	-0.055(0.192)[0.28] <sup>NS</sup>	-0.826(0.347)[2.37]*	-1.415(0.482)[2.93]**	-3.017(1.379)[2.18]*	<b>3</b>
$\Delta$ ISM <sub>t-3</sub>	-1.190(0.155)[7.66]***	-0.164(0.280)[0.58] <sup>NS</sup>	-1.455(0.389)[3.74]**	-3.099(1.113)[2.78]**	<b>3</b>
$\Delta$ PSM <sub>t-1</sub>	0.147(0.100)[1.47] <sup>NS</sup>	0.401(0.180)[2.21]*	-0.146(0.250)[0.58] <sup>NS</sup>	1.868(0.717)[2.60]**	<b>2</b>
$\Delta$ PSM <sub>t-2</sub>	-0.345(0.062)[5.49]***	0.083(0.113)[0.73] <sup>NS</sup>	-0.443(0.157)[2.81]**	-0.151(0.451)[0.33] <sup>NS</sup>	<b>2</b>
$\Delta$ PSM <sub>t-3</sub>	0.521(0.071)[7.24]***	0.026(0.129)[0.20] <sup>NS</sup>	0.104(0.180)[0.57] <sup>NS</sup>	2.015(0.515)[3.91]**	<b>2</b>
$\Delta$ CSM <sub>t-1</sub>	-0.143(0.065)[2.19]*	0.148(0.118)[1.25] <sup>NS</sup>	1.105(0.163)[6.74]***	-1.413(0.468)[3.01]**	<b>3</b>
$\Delta$ CSM <sub>t-2</sub>	-0.259(0.065)[3.97]**	0.211(0.117)[1.79] <sup>NS</sup>	0.633(0.163)[3.87]**	-0.987(0.467)[2.11]*	<b>3</b>
$\Delta$ CSM <sub>t-3</sub>	-0.149(0.035)[4.19]***	0.106(0.064)[1.65] <sup>NS</sup>	0.288(0.089)[3.23]**	-0.442(0.255)[1.73] <sup>NS</sup>	<b>2</b>
<b>ECT</b> <sub>t-1</sub>	-0.125(0.026)[4.73]***	-0.067(0.476)[0.14] <sup>NS</sup>	0.478(0.066)[7.23]***	-0.641(0.189)[3.39]**	
<b>ECT</b> <sub>t-2</sub>	0.122(0.033)[3.67]**	-0.253(0.598)[0.42] <sup>NS</sup>	0.499(0.083)[6.01]***	0.502(0.238)[2.11]*	
<b>ECT</b> <sub>t-3</sub>	0.007(0.008)[0.79] <sup>NS</sup>	-0.603(0.153)[3.93]**	-0.987(0.212)[4.65]***	-0.229(0.607)[0.37] <sup>NS</sup>	
<b>Influenced</b>	<b>9</b>	<b>1</b>	<b>10</b>	<b>9</b>	
<b>R<sup>2</sup></b>	<b>0.982</b>	<b>0.951</b>	<b>0.967</b>	<b>0.973</b>	
<b>D-W stat</b>	<b>1.99</b>	<b>2.70</b>	<b>2.912</b>	<b>1.636</b>	
<b>Autocor</b>	<b>8.452{0.585}</b>	<b>8.418{0.588}</b>	<b>9.559{0.455}</b>	<b>5.921{0.822}</b>	
<b>Arch effect</b>	<b>0.193{0.660}</b>	<b>0.415{0.414}</b>	<b>0.579{0.446}</b>	<b>0.166{0.683}</b>	
<b>Normality</b>	<b>17.390{0.0263}</b>				

Note: \*\*\* \*\* \* means significant at 1%, 5% and 10% respectively  
 Values in ( ); [ ] and { } are standard error, t-statistic and probability value



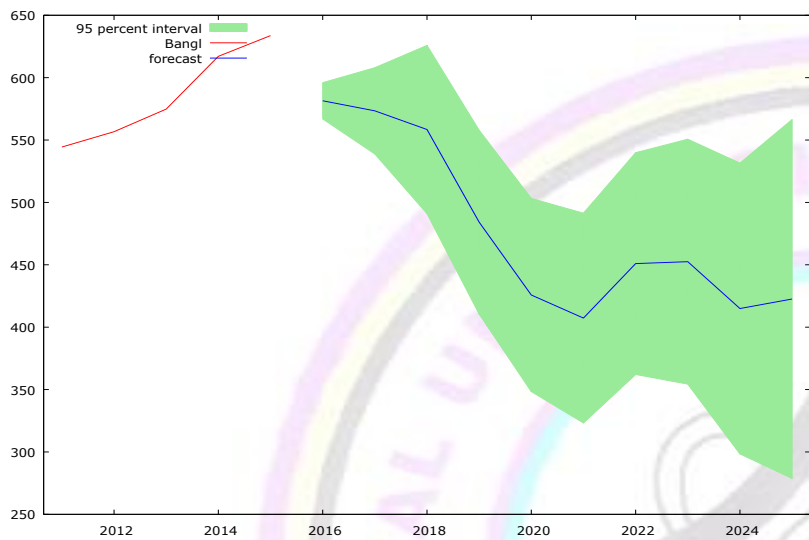


Figure 2a: Price forecast of Bangladesh sesame seeds

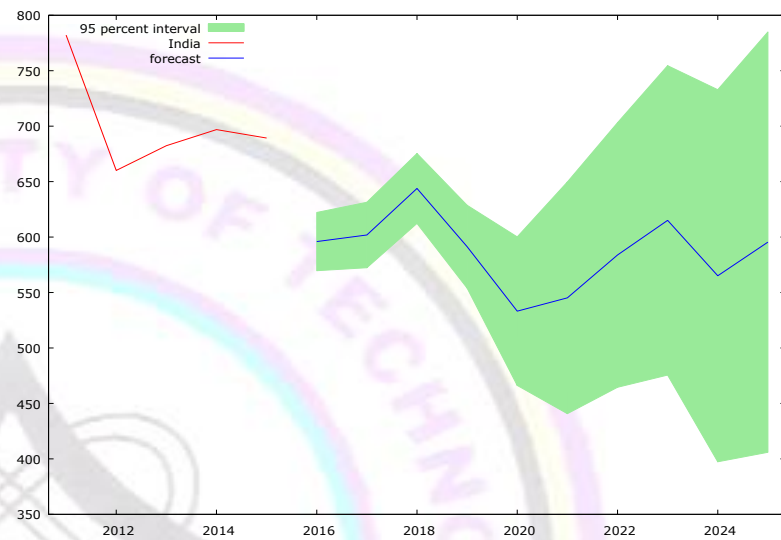


Figure 2b: Price forecast of India sesame seeds

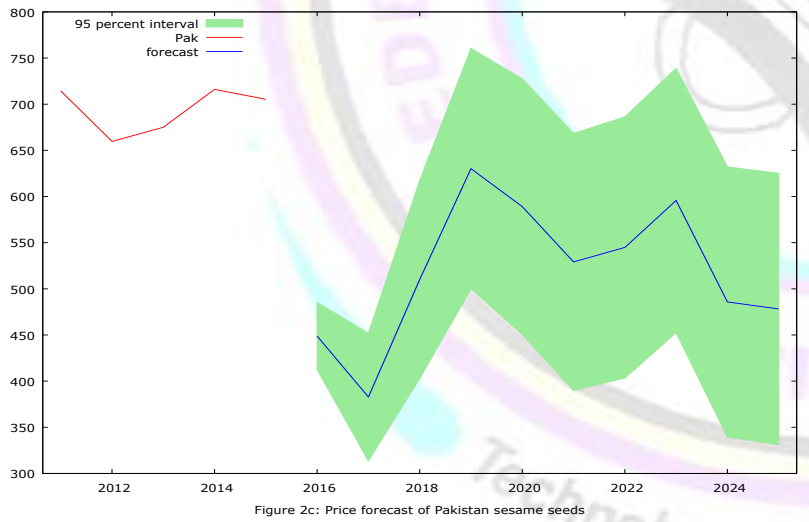


Figure 2c: Price forecast of Pakistan sesame seeds

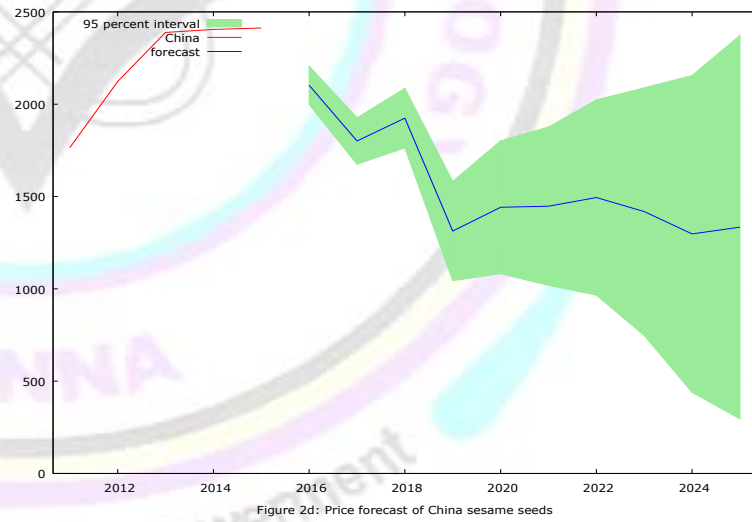


Figure 2d: Price forecast of China sesame seeds

Figure 2c: Price forecast of Pakistan sesame seeds

Figure 2d: Price forecast of China sesame seeds

# NATURAL FEED ADDITIVES FOR SUSTAINABLE ANIMAL PRODUCTION: BAKER'S YEAST (*SACCHAROMYCES CEREVISIAE*) SUPPLEMENTED-DIET IMPROVED NITROGEN (N) ABSORPTION IN RABBITS

Shehu<sup>1\*</sup>, B. M. and Ayanwale<sup>2</sup>, B. A.

<sup>1</sup>National Agricultural Extension and Research Liaison Services (NAERLS), Ahmadu Bello University, P.M.B 1067, Zaria, Nigeria

<sup>2</sup>Department of Animal Production, Federal University of Technology, Minna, Nigeria

\*Correspondence Author's E-mail: [balashehu@naerls.gov.ng](mailto:balashehu@naerls.gov.ng) and [shehubala@gmail.com](mailto:shehubala@gmail.com), GSM: 08050878016

## ABSTRACT

This study was undertaken to investigate Nitrogen (N) utilization of weaned rabbits fed diets supplemented with varying levels of baker's yeast containing *Saccharomyces cerevisiae* (SC). Forty-eight weaned rabbits in equal number of males and females, aged between 5 - 6 weeks with average initial live weight of  $614.5 \pm 57.72$  g were randomly allocated to four groups according to average body weight and sex, with 12 rabbits per group. Group SC0 was given a control diet without supplementation of SC, and groups SC2, SC4 and SC6 received the control diet supplemented with baker's yeast containing SC (Vahine®, Monteux, France) at the rate of 20, 40, and 60 g per kg for 8 weeks (corresponding to 0, 2, 4 and  $6 \times 10^9$  colony-forming unit/kg, respectively). Results from the study revealed the N balance in the manure of the control group (0.66 g/day) was significantly higher than those in the SC supplemented groups ( $P < 0.0001$ ). The lower N balance in the SC-supplemented groups could be attributed to the ability of dietary probiotics to reduce urease activity in the gut. These results suggest that dietary supplementation of rabbit's diets with SC improved N absorption and therefore, may indirectly lead to reduction in fecal odor, greenhouse gas (GHG) emissions and other environmental pollutants from animal manure.

**KEYWORDS:** Rabbit, Feed additives, Yeast (*Saccharomyces cerevisiae*), Nitrogen

## INTRODUCTION

Performance indices such as feed efficiency of most livestock species in Nigeria are inferior to those of their temperate counterparts (Shehu et al. 2014), resulting in economic loss and high nutrient concentrations in manures, which has been implicated in having negative environmental impacts such as deforestation, water and air pollution and biodiversity loss. Various sustainable strategies have been employed in developed countries to improve feed efficiency in livestock. Han *et al.* (2001) reviewed several studies, evaluating the use of feed additives and found that dietary supplementation with probiotics may indirectly lead to a reduction in environmental pollutants from animal manure, by improving feed efficiency and nutrient absorption. Therefore, the present study was undertaken to investigate Nitrogen (N) utilization of weaned rabbits fed diets supplemented with varying levels of baker's yeast containing SC.

## METHODOLOGY

### Study area

The study was conducted at the rabbitry unit of the Skills Acquisition and Entrepreneurship Development Centre (SAEDC) of the National

Agricultural Extension and Research Liaison Services (NAERLS), Ahmadu Bello University, Zaria (11° 12' N, 07° 33' E), located in the Northern Guinea Savannah zone of Nigeria.

### Experimental animals, diets and procedures

Forty-eight weaned heterogeneous breeds of rabbits in equal number of males and females, aged between 5 - 6 weeks with average initial live weight of  $614.5 \pm 57.72$  g were procured from a rabbit farm. They were randomly allocated to four groups according to average body weight and sex, with twelve rabbits per group. Group SC0 received a control diet without supplementation of SC, and groups SC2, SC4 and SC6 received the control diet supplemented with SC at the rate of 20, 40, and 60 g per kg for 8 weeks (corresponding to 0, 2, 4 and  $6 \times 10^9$  colony-forming unit/kg, respectively). A commercial baker's yeast, Vahine® (Avignon, Monteux, France), containing SC was used for the dietary supplementation. Proximate analysis of the basal mixture (control diet; SC0) which contained maize, soybean, maize offal, brewer's dried grain, groundnut cake, blood meal, rice offal and bone meal as main ingredients, showed that it contained 16.02% crude protein, 14.11% crude fibre (CF), 3.91% ether extract, and 10.21% ash/kg feed (Table 1). The diets were not pelleted and were

offered with clean fresh water *ad libitum*. Rabbits were individually housed in metabolism cages, which can separate urine from faeces. Feed and faeces samples were analyzed for dry matter (DM), CF, N, crude fat and energy according to the procedure of Yang (1993).

#### **Statistical analysis**

The data obtained were subjected to one-way ANOVA test in a completely randomized design using SAS 9.1 software package (SAS Institute, 2004), with the type of diet SC level serving as the main source of variation. The means were compared using Duncan's New Multiple Range Test (Duncan, 1955). Statistical significance was set at  $P < 0.05$ .

### **RESULTS AND DISCUSSION**

As shown in Table 2, the N balance in the manure of the control group (0.66 g/day) was significantly higher than those in the SC supplemented groups ( $P < 0.0001$ ). Rabbits in SC2 absorbed the least N (1.16 g/day), while those in SC4 and SC6 absorbed the most (1.37 g/day and 1.33 g/day) followed by rabbits in SC0 (1.25 g/day). The higher N-balance obtained in the control compared to that of the SC-supplemented group agrees with the reports of Yeo and Kim (1997), who reported lower N-balance due to dietary probiotics ability to reduce urease activity in the gut. Similarly, in another study by Santoso *et al.* (1999), dietary supplementation with a probiotic (*Bacillus subtilis*) improved N-absorption and was found to reduce NH<sub>3</sub> emissions in poultry house. In addition, Ferket *et al.* (2002) in his review suggested that faecal odour and NH<sub>3</sub> emission are related to nutrient utilisation and the intestinal microbiota and ecosystem. Han *et al.* (2001) reviewed several studies, evaluating the use of feed additives and found that dietary supplementation with probiotics may indirectly lead to a reduction in environmental pollutants from animal manure, by improving feed efficiency and nutrient absorption. Conversely to the result of this study, Kornegay and Risley (1996) evaluated the effects of two *Bacillus* products (Biomate2B®, composed of *B. subtilis* CH201 and *B. licheniformis* CH200, and Pelletmate Livestock®, composed of *B. subtilis*, *B. licheniformis* and *Bacillus pumilus*) in the diets of finishing pigs and found no impact on the N-balance. However, Min *et al.* (2004) reported positive effects in the dry matter digestibility and N-balance in nursery pigs fed diets that were supplemented with 0.04% BioPlus 2B®, a commercial probiotic.

### **CONCLUSION AND RECOMMENDATIONS**

These results suggest that dietary supplementation of rabbit's diets with SC improved N absorption and therefore, may indirectly lead to reduction in fecal

odor, greenhouse gas (GHG) emissions and other environmental pollutants from animal manure.

### **ACKNOWLEDGEMENTS**

The authors gratefully acknowledge the Tertiary Education Fund of Nigeria (TETFund) for partially financing this study.



Table 1: Ingredients and nutritional composition of basal diet

Ingredients	Percentage
Maize	25.00
Soybean meal	5.00
Maize offal	15.00
Brewer's dried grain	25.00
Blood meal	2.00
Groundnut cake	12.00
Rice offal	12.00
Bone meal	3.00
Salt	0.25
Premix <sup>a</sup>	0.25
Lysine	0.25
Methionine	0.25
<b>Total</b>	<b>100</b>
<b>Determined nutrient composition</b>	
Dry matter (%)	94.63
Crude protein (% DM)	16.02
Crude fibre (% DM)	14.11
Ether extract (% DM)	3.91
Ash (% DM)	10.21
Nitrogen free extract (% DM)	50.38
Metabolizable energy (Kcal/kg)	2607.80

DM = Dry matter.

<sup>a</sup>Provided per kilogram of diet: vitamin A, 10 000 IU (retinyl acetate); cholecalciferol, 3000 IU; vitamin E, 8.0 IU (DL- $\alpha$ -tocopheryl acetate); vitamin K, 2.0 mg; thiamine, 2.0 mg; pyridoxine, 1.2 mg; cyanocobalamin, 0.12 mg; niacin, 1.0 mg; pantothenic acid, 7.0 mg; folic acid, 0.6 mg; choline chloride, 500 mg; Fe, 60 mg; Mn, 100 mg; Cu, 8.0 mg; Zn, 50 mg; Co, 0.45 mg; I, 2.0 mg; Se, 0.1 mg.

Table 2: Nitrogen (N) utilization of weaned rabbits fed diets supplemented with varying levels of SC

	Dietary treatments				s.e.m	P-value
	SC0	SC2	SC4	SC6		
N intake (g/day)	1.69 <sup>b</sup>	1.61 <sup>b</sup>	1.85 <sup>a</sup>	1.87 <sup>a</sup>	0.03	<0.001
Faecal N (g/day)	0.44	0.45	0.53	0.50	0.02	NS
Urinary N (g/day)	0.59 <sup>c</sup>	0.84 <sup>b</sup>	0.97 <sup>a</sup>	0.97 <sup>a</sup>	0.04	<0.001
N absorbed (g/day)	1.25 <sup>ab</sup>	1.16 <sup>b</sup>	1.33 <sup>a</sup>	1.37 <sup>a</sup>	0.02	<0.001
N balance (g/day)	0.66 <sup>a</sup>	0.32 <sup>b</sup>	0.35 <sup>b</sup>	0.39 <sup>b</sup>	0.04	<0.001
NB as % of N- intake	38.95 <sup>a</sup>	19.80 <sup>b</sup>	18.86 <sup>b</sup>	20.90 <sup>b</sup>	2.18	<0.001

## REFERENCES

- Duncan, D.B. (1955). New multiple range and multiple F-test. *Biometrics II*, pp.1-42.
- Ferket, P.R., van Heugten, E., van Kempen, T.A.T.G. and Angel, R. (2002). Nutritional strategies to reduce environmental emissions from nonruminants. *Journal of Animal Science*, 80(2), E168-E182.
- Han, I.K., Lee, J.H., Piao, X.S. and Li, D. (2001). Feeding and management system to reduce environmental pollution in swine production: a review. *Asian-Australasian Journal of Animal Sciences*, 14 (3), 432-444.
- Kornegay, E.T. and Risley, C.R. (1996). Nutrient digestibilities of a corn-soybean meal diets as influenced by *Bacillus* products fed to finishing swine. *Journal of Animal Science*, 74, 799-805.
- Min, B.J., Kwon, O.S., Son, K.S., Cho, J.H., Lee, W.B., Kim, J.H., Park, B.C. and Kim, I.H., (2004). The effect of *Bacillus* and active yeast complex supplementation on the performance, faecal *Bacillus* counts and ammonia nitrogen concentrations in weaned pigs. *Journal of Animal Science*, 82 (1), 26.
- Santos, U., Ohtani, S., Tanaka, K. and Sakaida, M. (1999). Dried *Bacillus subtilis* culture reduced ammonia gas release in poultry house. *Asian-Australasia Journal of Animal Sciences*, 12(5), 806-810.
- Shehu, B. M., Ayo, J.O., Ayanwale, B.A., Jiya, E.Z and Tsado, D.N. (2014). Growth performance and nutrient digestibility of weaned rabbits fed diets supplemented with varying levels of baker's yeast (*Saccharomyces cerevisiae*). *International Journal of Agriculture and Rural Development*. Vol. 17 (1): Pp1619-1627.
- Yang S 1993. Feed analysis and feed quality assay. Beijing Agricultural University Press.
- Yeo, J. and Kim, K. (1997). Effect of feeding diets containing an antibiotic, a probiotic or yucca extract on growth and intestinal urease activity in broiler chicks. *Poultry Science*, 76, 381-38.

## RESPONSE OF COWPEA TO RHIZOBIAL INOCULATION IN SOILS OF SOME COWPEA GROWING AREAS OF NIGER STATE

Tanko, F., D.T Ezekiel-Adewuyin., A. O. Osunde, and A. Bala

*Department of Soil Science and Land Management, School of Agriculture and Agricultural Technology, Federal University of Technology Minna, PMB 65, Minna Niger State.*

Email: [f.tanko@futminna.edu.ng](mailto:f.tanko@futminna.edu.ng); [Tyma2k4@yahoo.com](mailto:Tyma2k4@yahoo.com) GSM: 07039754192

### ABSTRACT

Yield of cowpea in soils of Nigeria Savanna is often low as a result of deficiency of nutrient particularly Nitrogen. The use of rhizobia inoculants may benefit the cowpea plant through improve Biological Nitrogen Fixation. The objective of this study was to determine the response of cowpea varieties to Bradyrhizobium inoculation in soils of some cowpea growing areas of Niger State. Two greenhouse experiments were carried out at the Teaching and Research Farm of the Federal University of Technology Minna to determine (i) the size of the native rhizobial using Most Probable Number (MPN) method which was a 2 x 4 factorial experiment, and (ii) Need to Inoculate cowpea experiment laid out in a 10 x 2 x 4 x 4 fitted to a completely randomized block design. The treatment consisted of (i) proximities (close to homestead < 50 m, and far from homestead > 250 m) and (ii) cowpea varieties (Kanannado, IT93K-452-1, IT97K-499-35, and IT90K-277-2) for MPN. Treatments for need to inoculate trial consisted of (i) 10 locations (Rijau, Kontagora, Magama, Mashegu, Mariga, Bida, Paikoro, Wushishi, Chanchaga, and Bosso), (ii) 2 proximities to homestead, (iii) 4 cowpea varieties, (Proximity to homestead and cowpea varieties were the same as in the MPN experiment), and (iv) 4 nitrogen sources (N treated plants in form of urea at the rate of 100 kg N ha<sup>-1</sup>, plants inoculated with Bradyrhizobium sp. strain BR 3262 or BR 3267, and control. The result of this study shows that MPN estimate using IT90K-277-2 as the trap host (9.41 x 10<sup>6</sup> cells g<sup>-1</sup>) was significantly lower than estimates by the other varieties (1.29 - 2.23 x10<sup>7</sup> cells g<sup>-1</sup>), there was no significant difference between either of the proximities to homestead. Cowpea varieties used in this study responded to either or both inoculant strains, response to inoculation using strain BR 3262 ranged from 10.42% to 27.26% and 15.04% to 55.17% with strain BR 3267. There exists a linear relationship between symbiotic effectiveness of the native rhizobial populatons and response to inoculation. Suggesting the suitability of these inoculant strains for cultivation in the Southern Guinea savanna of Nigeria.

**Keyword:** cowpea, rhizobia, *Bradyrhizobium* inoculants

---



## INTRODUCTION

The most frequently deficient nutrient in tropical soils is nitrogen, due to continual removal of crop residues, low soil organic matter, leaching, bush burning, and volatilization (Albareda *et al.*, 2008). In order to optimize the supply of this nutrient in agricultural systems, legumes such as cowpea that biologically fix nitrogen are integrated as part of the cropping systems. Nitrogen inputs through biological nitrogen fixation (BNF) may sometimes be sub-optimal because of the absence or low number of effective indigenous rhizobia that are compatible with the host legume (O'Hara *et al.*, 2002). Under these circumstances, BNF can be improved through inoculation of soils with effective and compatible elite rhizobial strains (Abaidoo *et al.*, 2007).

However, inoculation does not always bring about positive response. Among the frequently mentioned causes of failure are the number and the symbiotic effectiveness of indigenous rhizobia (Thies *et al.*, 1991). In other cases, inoculating cowpea with rhizobia has been used to achieve substantial increases in legume nodulation, grain and biomass yield, nitrogen fixation and post-crop soil nitrate levels (Thies *et al.*, 1991). These gains are usually highest when the inoculated legumes are grown in nil-rhizobia or low-rhizobia soils, but marginal in soils already containing high number of compatible rhizobia (GRDC, 2013). In Southern Africa, there are results showing existence of inter and intra-field variability in soil fertility. Farmers preferably apply nutrient resources to fields closest to homesteads leading to gradients of decreasing soil fertility with increasing distance from homesteads (Zingore *et al.*, 2007). Cowpea is a staple crop in Nigeria and West Africa at large but the yield of cowpea remains as low as 450 kg ha<sup>-1</sup> in Nigeria small holder farms depending on varieties, management practices and climatic conditions (Cissé and Hall, 2003). Therefore this study was carried out to determine (i) To determine the varietal response of cowpea to different strains of rhizobia inoculants in soils of some cowpea growing areas of Niger State (ii) To investigate the relationship that exists between the size of the indigenous rhizobia population and cowpea response to inoculation, (iii) To establish the relationship between cowpea response to inoculation and the symbiotic efficiency of the indigenous rhizobial population, and (iv) To determine whether there exist differences in soil physico-chemical and biological properties between soils of field located near farm homesteads and those further away and how soils from either fields affect cowpea response to inoculation.

## MATERIALS AND METHODS

### The Study Area

The study was conducted in the greenhouse of the Federal University of Technology Minna. The study area is located in the Southern Guinea Savannah of Nigeria which lies between longitudes 9° 30' and 9° 40' E and latitudes 6° 30' and 6° 35' N at an elevation of about 258.5m above sea level.

The mean annual rainfall is about 1,338 mm which falls between April/May and October, November. The effective length of wet season is about 5 months. The highest mean monthly rainfall is in September with 300 mm. The temperature rarely falls below 22°C. The peaks are 40°C between February to March and 35°C between November and December (Osunde *et al.*, 2003).

### Soil sampling and analysis

Soil samples were collected from 20 different points each at 0-20cm depth and were bulked to form composites. The soil samples were taken to the laboratory and a subsample taken and air-dried for physico-chemical analyses. The remaining samples were prepared moist for greenhouse study. Soil aggregates were gently crushed and passed through a 2mm sieve. Physical and chemical properties were carried out by standard methods (IITA, 1989), with soil particle size determined by the hydrometer method and pH using a pH-meter in water (soil solution ratio 1:2:5). Soil organic matter was determined using the Walkley and Black method, total nitrogen by the Kjeldahl method and available phosphorus by the Bray P1 method.

### Green house study

#### Experiment (i) Procedure for the MPN Method

The assay was conducted using modified Leonard jar method in Southern Australia (Howieson *et al.*, 2014) using coarse sand as the potting medium. The coarse sand was washed several times with tap water to remove all traces of dissolved nutrients and finally rinsed with sterile distilled water before sun drying.

A 3 litre pot was filled with 2.5 kg of sand medium to which 200 ml of calcium solution was added. Cowpea seeds were sown at the rate of 3 seeds per pot and thinned to 1 per pot a week after planting. Plants were watered daily using sandsman's nitrogen free nutrient solution (Sandsman, 1970). One week after planting, the plants were inoculated with 1 ml aliquots of the soil suspensions made from serial dilution of the soil samples. Each soil sample was initially diluted 20-fold by adding 10g of soil in 190 ml of sterile distilled water. Each dilution level was replicated four times resulting in a total of 24 pots per each soil sample.

Harvesting was done in a period of seven weeks after planting to observe the patterns of nodule appearances. The (+) sign was used to indicate presence of at least one nodule, while (-) denoted absence of nodules (Vincent, 1970).

#### Experiment (ii) Need to Inoculate Assay

Soil samples were added to 2.5 litre pot at 2 kg per pot. To each pot was added 372.6 mg of P, K, Mg, Zn, Mo, and B fertilizer and thoroughly mixed. Cowpea seeds were planted at 3 per pot and thinned to two per pot one week after emergence. The plants were watered daily with sandman's N free nutrient solution 200 ml per pot for the first four weeks and later one quarter strength of the solution or just sterile distil water plants were harvested 7 weeks after planting. N treated plants were supplied with nitrogen and was split applied to the N treatment at first week (81.60 mg) and second week (244.80 mg) after planting. Inoculants were applied to the seeds before planting in inoculated treatment. The following parameters were carried out shoot weight (dry), Nodule number, Nodule weight (dry), Nodule activity.

#### **Experimental design and statistical analysis**

Experiment (i) was arranged in a 2 x 4 factorial combination fitted to completely randomised design replicated four times. Proximity to homestead (2) and varieties (4) proximity to homestead and varieties were the same as that of experiment (ii). Experiment (ii) was arranged in a 10 x 2 x 4 x 4 factorial combination fitted to completely randomised design replicated four times. Locations (10), Proximity to homestead (2), nitrogen sources (4), and varieties (4). The locations were (Rijau, Kontagora, Magama, Mashegu, Mariga, Bida, Paikoro, Wushishi, Chanchaga, and Bosso). Proximity to homestead was either close or far from the homestead. N sources were (i) plant treated with nitrogen in form of urea at the rate of 100 kg N ha<sup>-1</sup>, (ii) plant inoculated with *Bradyrhizobium* sp. strain BR 3262 or *Bradyrhizobium* sp. strain BR 3267, and control (Neither N nor inoculant rhizobia applied). The cowpea varieties were IT93K-452-1 (extra-early Maturing), IT97K-499-35 (Early Maturing), IT90K-277-2 (Medium Maturing), Kanannando (Late Maturing).

The data were subjected to statistical analysis using MINITAB 17.0. Analysis of variance (ANOVA) of the general linear model was used to check for significant effects and significant means were separated using Fisher least significant difference (L.S.D) method.

## **RESULTS**

### **Soil Characteristics of the study area**

The physical and chemical properties of soils used for this experiment are presented in (Table 1). Soils obtained from Bida, both close and far from homestead and those sampled from site far from homestead in Wushishi as well as the soil close to homestead in Mashegu were classified as sandy soil. Soils from Chanchaga and Bosso that were sampled from either close or far proximities were sandy loam. Similarly soils from Mashegu and

Rijau sampled far from homestead and those from Magama close to homestead were also sandy loam. Loamy sand texture was obtained in the other locations.

The soil pH for both soils obtained close and further away from homestead in the 10 locations was slightly acidic to near neutral ranging from 5.31- 6.79 but a moderate acidity of 4.77 was observed in Kontagora for soils sampled near the homestead.

Soil organic carbon was low but moderate in soils close to homestead. Chanchaga and Kontagora at 0.50 g kg<sup>-1</sup> and 12.45 g kg<sup>-1</sup> respectively. Total soil N was very low for all locations in both the close or far proximities to homestead. Available P ranges from low to moderately high but very high in Mariga soils obtained further away from homestead and Wushishi close to homestead. Exchangeable bases were moderately high in all locations. The result of the Effective cation exchange capacity (ECEC) ranges between 11.40 cmol kg<sup>-1</sup> and 5.79 cmol kg<sup>-1</sup> with the highest observed in Wushishi for soils collected close to homestead

### **Estimate for rhizobial population for four variety of cowpea at different location**

The rhizobial populations as estimated using four (4) cowpea varieties as trap host are presented in Table 2. The soils of the study sites had high numbers of indigenous rhizobia (>10 rhizobia cells g<sup>-1</sup> of soil). However, the highest population was observed in Mashegu for soils sampled near homestead, Mariga, and Magama for soils far away from homestead (71.84 x 10<sup>6</sup> cell g<sup>-1</sup> of soil) using Kanannado variety while the lowest native populations (4.61 x 10<sup>6</sup> cell g<sup>-1</sup> of soil) were obtained using IT93K-452-1 variety for Bida, Kontagora, Rijau for soils sampled close to homestead these was similar to Bosso for soils far away from homestead using Kanannado variety.

### **The effect of proximity to homestead and varieties on the most probable number (MPN) of indigenous rhizobial population.**

The main effect of proximity to homestead did not significantly (p>0.05) affect the native rhizobia population of the soils Table 3. However, varieties significantly affected the rhizobia population and the greatest MPN value was obtained using Kanannado compared to IT93K-452-1, IT97K-499-35, and IT90K-277-2 varieties. The interaction of proximity to homestead and varieties did not significantly affect (P>0.05) the population of indigenous rhizobial present in the experimental soil.

### **Effect of nitrogen sources, proximity to homestead and varieties on shoot dry weight of cowpea**

The main effect of nitrogen sources significantly (P<0.05) affected shoot dry weight of cowpea at all locations (Table 5). The Urea treated plants



produced the highest shoot dry weight of cowpea in all locations while the control plants had the smallest shoot biomass in all locations, except in Chanchaga soils where the BR 3267 plants had the smallest biomass. However, there was a significant response of cowpea to inoculation except for chanchaga soils, plant inoculated with either or both of the inoculant strains produced the greater shoot dry weight than the control in all soils. The BR 3262 had better shoot dry weight than the control at four of the ten locations, while the BR3267 treatment had the higher shoot dry weight than the control at seven out of ten locations.

The main effect of proximity to homestead on shoot dry weight of cowpea was significant ( $P < 0.05$ ) for all locations except in Magama, Chanahaga, and Paiko (Table 5). Except in Bosso, soils sampled close to homestead supported higher cowpea shoot dry matter than soils further away from homestead.

The varietal effect on shoot dry weight was significant in all ten locations (Table 5). The Kanannado variety produced the highest shoot dry weight while IT90K-277-2 variety had the smallest dry weight in all locations. IT93K-452-1 and IT97K-499-35 produced similar shoot biomass at seven out of the ten locations, while the later had higher biomass than the former at the other three locations.

The Interaction effect of nitrogen source, proximity to homestead and varieties significantly ( $P < 0.05$ ) affected the shoot dry weight of cowpea in all locations .

#### **The interactive effect of treatments on shoot dry weight of cowpea in Mashegu**

The Kanannado plant inoculated with BR3262 as well as IT93K-452-1 and IT90K-277-2 plants inoculated with BR3267 and grown in the soil sampled close to the homestead produced the highest shoot dry weight. These are however, similar to those produced by the N treated Kanannado and IT90K-277-2 plant grown in soils sampled further from the homestead and that close to the homestead, respectively.

The least shoot dry biomass was produced by the IT93K-452-1, IT97K-499-35 and IT90K-277-2 that were treated with neither N or inoculant in soils sampled from both close and far from homestead. Similar biomass yields were all produced Kanannado and IT93K-452-1 inoculated with BR3267 and by IT93K-452-1 and IT90K-277-2 inoculated with BR3267 in soils sampled far from homestead.

#### **The interaction of treatments on shoot dry weight of cowpea in soils from Rijau**

The interactive effects of the treatments on shoot dry weight of cowpea are presented in (Table 6). The Kanannado and IT93K-452-1 plant treated with N in soils close to homestead had the heaviest

shoot weight while the IT90K-277-2 that were inoculated with either BR3262 or BR3267 in soils close to homestead produced the least shoot biomass. However, IT97K-499-35 inoculated with BR3267 in the soils sampled close to homestead produced as much biomass as the N - treated with IT97K-499-35 and IT90K-277-2.

#### **The interaction of treatments on shoot dry weight of cowpea in soils from Chanchaga**

The N treated Kanannado and IT97K-452-1 in both soils of far and near proximities had the highest biomass weight. This was however, not significantly different from the dry matter weight of the unamended kanannado plants and those inoculated with BR3262 in soils close to homestead.

The BR3262 plants irrespective of variety were among the treatments with the least biomass.

## **DICUSSIONS**

### **Soil physicochemical analyses**

The physical and chemical properties of the soil at the experimental site reflected the common features of savanna soils which are generally low in organic carbon and very low in total N contents (Aliyu *et al.*, 2013). On the other hand, the extractable P of the soil falls within optimum available P concentration that would help to enhance nodulation and nitrogen fixation in the grain legume (Enwezor, 1990). The ECEC analysis shows that soils sampled close to homestead contained more nutrient than those sampled away from homestead, this is in consistence with the findings of (Zingore *et al.*, 2007) In Southern Africa, that farmers preferably apply nutrient resources to fields closest to homesteads leading to gradients of decreasing soil fertility with increasing distance from homesteads.

### **Most Probable Number (MPN)**

The MPN results of the experimental soils show that N has fixing ability for cowpea. The likelihood of response to inoculation can also be assessed by counting the population of rhizobia in soil using appropriate host (Woomer *et al.*, 1990). If small populations of effective rhizobia are present (20-50 cells/g), then it is likely that a yield response will be found (Thies *et al.*, 1991). The rhizobial cell count in this study indicated that soils sampled away from homestead had higher population density of cowpea rhizobia compared to proximities close to homestead. These suggest that there may likely be no response to inoculation in these soils. Contrary to this observation, a response was observed in this study. **Effect of nitrogen sources on the shoot dry weight of cowpea**

The success of Rhizobium inoculation primarily depends on the rhizobial strain, the legume genotype, the environmental conditions, and the crop management (Woomer *et al.*, 2014). Cowpea



shows response to inoculation, but greatest shoot dry weight was obtained with urea treated plant at the rate of 100 kgNha<sup>-1</sup>, this implies that N was limiting in soils of the study sites. This result agrees with the findings of Subasinghe *et al.* (2001) who reported an increase in dry matter production of cowpea in response to increased N application. Although, the inoculated plant did as well as the N supplied plant in some locations and also better than the control treatment in all location except in Chanchaga despite its promiscuity to indigenous rhizobia in soil. This is in contrast with some reports from the past suggesting that cowpea yields are not improved by rhizobia inoculation (Awonaike *et al.*, 1990; Mathu *et al.*, 2012). This result conforms to the findings of Zilli *et al.* (2009) who reported an increase in biomass production following inoculation of cowpea with inoculant (BR3267) were more than the biomass produced with indigenous rhizobia population.

In this study, proximity of fields to homesteads yields were significantly higher which is in accordance to the research carried out in South Africa by Waddington and Karigwindi (2001); Zingore *et al.* (2007) whose study shows that the fertile plots is often closest to homesteads, as a result of continuous accumulation of organic amendment including all kinds of manure and household waste applied directly surrounding the villages.

Symbiotic effectiveness is one of the important parameters for selecting strains for inoculant

**Table 1 Physico-chemical properties of the soils used for the study**

Location	Proximity	pH CaCl	OC g kg <sup>-1</sup>	N g kg <sup>-1</sup>	Avail.P mg kg <sup>-1</sup>	Textural Class	K	Mg	Ca	Exch. acidity	ECE C
							cmol Kg <sup>-1</sup>				
Bida	Close	6.29	4.20	0.11	10.0	S	0.17	0.96	5.36	0.07	6.98
	Far	6.18	1.95	0.07	6.0	S	0.15	0.85	5.12	0.10	6.68
Kontagora	Close	4.77	12.45	0.20	18.0	LS	0.28	1.60	5.20	0.10	7.64
	Far	5.31	2.55	0.10	6.0	LS	0.18	0.88	4.40	0.10	6.13
Mashegu	Close	5.84	3.75	0.10	6.0	S	0.38	0.64	4.64	0.15	6.34
	Far	5.97	4.95	0.08	5.0	SL	0.26	0.96	5.60	0.09	7.43
Rijau	Close	6.57	4.80	0.06	8.0	LS	0.35	0.64	4.64	0.09	6.17
	Far	5.99	6.15	0.15	9.0	SL	0.21	0.88	4.88	0.08	6.49
Mariga	Close	5.78	6.45	0.22	6.0	LS	0.33	0.96	6.40	0.07	8.25
	Far	5.85	8.25	0.10	31.0	LS	0.27	1.36	5.20	0.27	7.53
Wushishi	Close	6.75	4.20	0.13	61.0	LS	1.00	1.60	7.60	0.69	11.4
	Far	5.48	2.10	0.13	5.0	S	0.15	1.12	5.28	0.25	7.27
Magama	Close	5.47	2.70	0.14	6.0	SL	0.12	0.56	4.56	0.12	5.79

production. It is also a primary factor for the determination of incidence and magnitude of legume response to inoculation (Thies *et al.* 1991). IT97K-499-35 and IT90K-277-2 varieties had the highest frequency of response to inoculation while the least was with Kanannado variety. Cowpea varieties used in this study responded to either or both inoculant strains, response to inoculation using strain BR 3262 ranged from 10.42% to 27.26% and 15.04% to 55.17% with strain BR 3267.

#### CONCLUSION

Soils sampled from different locations in this study have enabled understanding of effects of inoculation on the yield parameters of cowpea. Soils from the cowpea growing areas of Niger state contains large population of indigenous rhizobia that nodulate cowpea with population ranging from 4.61 x 10<sup>6</sup> to 7.19 x 10<sup>6</sup> cells g<sup>-1</sup>. There were no significant differences in rhizobia number in soils sampled close to homestead and those away from homestead. In spite of the relatively large numbers of the indigenous rhizobia in the soils, cowpea responded to rhizobia inoculation in 19 of the 20 soils. Response to inoculation using strain BR 3262 ranged from 10.42% to 27.26%. In the case of strain BR 3267, it ranged from 15.04% to 55.17%. Variety IT97K-499-35 had the highest frequency of response to rhizobial inoculation at 70%, while the local variety, Kanannado, was the least frequent at 50%.

	Far	5.57	3.75	0.20	7.0	LS	0.35	0.80	5.44	0.07	7.18
Bosso	Close	5.74	7.95	0.24	5.0	SL	0.28	2.00	6.00	0.30	9.06
	Far	5.98	4.65	0.17	5.0	SL	0.35	1.84	5.60	0.12	8.35
Chanchaga	Close	6.79	10.50	0.17	15.0	SL	0.57	0.80	7.76	0.11	9.74
	Far	5.63	6.00	0.08	5.0	SL	0.23	1.20	7.44	0.20	9.56
Paiko	Close	5.36	3.60	0.11	6.0	LS	0.19	1.12	4.80	0.10	6.71
	Far	5.80	4.35	0.18	7.0	LS	0.22	0.80	5.04	0.21	6.76

\*SL-sandy loamy \*LS-loamy sand \*S-sandy



**Table 2: Estimate of rhizobial populations for four varieties of cowpea at different location in (x10<sup>6</sup> cell g<sup>-1</sup> of soil)**

Location	Proximity	Kanannado	IT93K-452-1	IT97K-499-35	IT90K-277-2	Means
Bida	Close	7.19	4.61	12.27	10.94	<b>8.75</b>
	Far	10.94	7.19	9.26	7.19	<b>8.65</b>
Kontagora	Close	10.94	4.61	11.24	7.19	<b>8.50</b>
	Far	22.48	31.85	12.27	11.24	<b>19.46</b>
Mashegu	Close	71.89	22.48	11.24	7.19	<b>28.2</b>
	Far	12.27	22.48	11.24	7.19	<b>13.30</b>
Rijau	Close	12.27	4.61	9.26	12.27	<b>9.60</b>
	Far	12.27	12.27	9.26	10.94	<b>11.19</b>
Mariga	Close	22.48	42.59	11.24	7.19	<b>20.88</b>
	Far	71.89	12.27	12.22	11.24	<b>26.91</b>
Wushishi	Close	10.94	10.94	7.19	7.19	<b>9.07</b>
	Far	12.27	10.94	9.26	11.24	<b>10.93</b>
Magama	Close	22.48	10.94	42.59	7.19	<b>20.80</b>
	Far	71.89	12.27	11.24	11.24	<b>26.66</b>
Bosso	Close	10.94	12.27	12.22	9.26	<b>11.17</b>
	Far	4.61	10.94	12.22	11.24	<b>9.75</b>
Chanchaga	Close	12.27	11.24	9.26	9.26	<b>10.51</b>
	Far	22.48	11.24	22.48	7.19	<b>15.85</b>
Paiko	Close	12.27	12.27	9.26	10.94	<b>11.19</b>
	Far	11.28	11.28	12.22	10.94	<b>11.43</b>
<b>Means</b>		<b>22.30</b>	<b>13.96</b>	<b>12.87</b>	<b>9.41</b>	

**Table 3 The effect of most probable number (cells g<sup>-1</sup> of soil) of indigenous rhizobial in soils sampled from different location in Niger State.**

Treatment	MPN
<b>Proximity (P)</b>	
Close	1.39x10 <sup>6</sup> a
Far	1.54x10 <sup>6</sup> a
L.S.D (0.05)	NS
<b>Varieties (V)</b>	
Kanannado	2.23x10 <sup>7</sup> a
IT93K-452-1	1.40x10 <sup>7</sup> a
IT97K-499-35	1.29x10 <sup>7</sup> a
IT90K-277-2	9.00x10 <sup>6</sup> b
Interaction	
P X V	NS

Means with the same letters are not statistically different (P>0.05)

Treatment	Bida	Kontagora	Mashegu	Rijau	Mariga	Wushishi	Magama	Bosso	Chanchaga	Paiko
-----------	------	-----------	---------	-------	--------	----------	--------	-------	-----------	-------



Nitrogen sources(N)										
Control	1.44c	1.27c	1.16c	1.39c	1.52 b	1.44b	1.13c	1.59 c	1.94a	1.64b
Urea	2.09a	1.87a	1.86a	2.13a	2.06 a	1.98a	1.75a	2.32 a	1.94a	2.01a
BR 3262	1.31c	1.54b	1.48b	1.36c	1.50 b	1.59b	1.27b c	2.02 a	1.71b	1.97a
BR 3267	1.69b	1.22c	1.80a	1.65b	1.91 a	1.90a	1.30b	1.85 b	1.49c	2.05a
Significance	**	**	**	**	**	**	**	**	*	*
LSD (0.05)	0.18	0.17	0.17	0.23	0.25	0.18	0.16	0.22	0.22	0.22
Proximity (P)										
Close	1.78a	1.55a	1.70a	1.63a	1.85 a	1.86a	1.33a	1.86 b	1.77a	1.91a
Far	1.48b	1.40b	1.45b	1.63a	1.64 b	1.60b	1.40a	2.03 a	1.76a	1.93a
Significance	**	*	*	NS	*	*	NS	*	NS	NS
LSD (0.05)	0.13	0.12	0.12	0.16	0.17	0.13	0.11	0.15	0.15	0.15
Varieties (V)										
Kanannado	2.11a	1.95a	1.88a	2.01a	2.02 a	2.13a	1.67a	2.44 a	2.02a	2.22a
IT93K-452-1	1.47c	1.39b	1.34c	1.65b	1.89 ab	1.43c	1.17c	1.96 b	1.59b	1.86b
IT97K-499-35	1.84b	1.42b	1.49bc	1.72b	1.71 b	1.83b	1.38b	2.03 b	1.74b	2.07ab
IT90K-277-2	1.10d	1.14c	1.58b	1.16c	1.37 c	1.52c	1.23b c	1.35 c	1.72b	1.52c
Significance	**	**	**	**	**	**	**	**	*	**
LSD (0.05)	0.18	0.17	0.17	0.23	0.25	0.18	0.16	0.22	0.22	0.22
Interaction										
N X P	NS	NS	*	*	NS	*	NS	**	*	**
N X V	**	**	**	**	**	**	NS	*	**	**
P X V	NS	NS	*	NS	**	NS	NS	*	*	NS
N X P X V	*	*	*	*	*	**	*	**	**	*

Table 4 Effect of nitrogen sources, proximity to homestead and varieties on shoot dry weight (g/ plant) of cowpea  
Means with the same letters in a column under a treatment are not statistically different ( $P>0.05$ ). Significant at ( $P<0.05$ ), \*\* highly Significant at ( $P<0.05$ ), NS (not significant)

Table 5 Interaction effect of nitrogen sources, proximity of field to homestead and varieties on shoot dry weight of cowpea in Mashegu Niger state.

Varieties

Nitrogen sources	Proximity	Varieties			
		Kanannado	IT93K-452-1	IT97K-499-35	IT90K-277-2
Control	Close	1.74e-i	1.15k-p	1.07l-p	1.20k-p
	Far	1.34i-o	0.96m-p	0.93nop	0.90op
Urea	Close	2.23b-e	1.28i-p	1.49f-l	2.31a-d
	Far	2.78a	1.98c-f	1.51f-l	1.31i-p
BR3262	Close	2.43abc	1.07l-p	1.41h-n	1.60f-k
	Far	1.91d-g	0.82p	1.70f-j	0.90op
BR3267	Close	1.42g-m	2.33a-d	1.91d-g	2.53ab
	Far	1.23j-p	1.17k-p	1.95c-f	1.85d-h

Means with the same letters are not statistically different (P>0.05)

**Table 6 Interaction effects of nitrogen sources, proximity to homestead and varieties on shoot dry weight of cowpea in soils sampled from Rijau.**

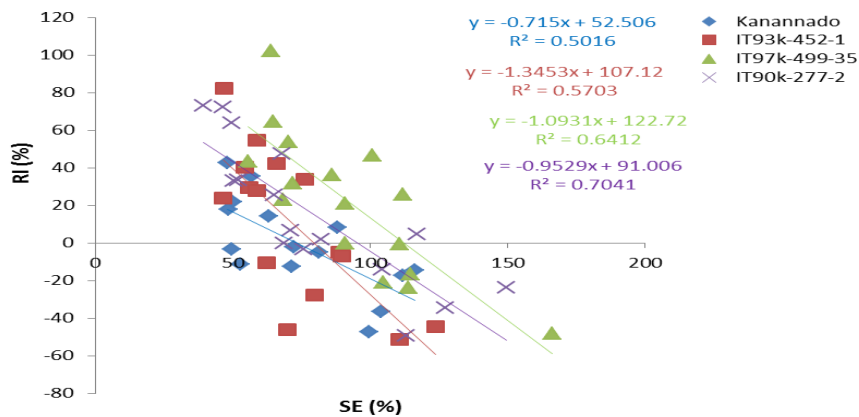
Nitrogen sources	Proximity	Varieties			
		Kanannado	IT93K-452-1	IT97K-499-35	IT90K-277-2
Control	Close	1.69e-i	0.96j-n	1.26i-m	0.98j-m
	Far	1.94c-h	1.55e-k	1.41g-l	1.30h-m
Urea	Close	3.20a	2.81ab	1.85c-i	1.61e-j
	Far	2.20b-e	2.49bc	1.40g-l	1.52f-k
BR3262	Close	1.50f-k	0.91k-n	1.55e-k	0.84lmm
	Far	2.13c-f	1.39g-l	2.07c-f	0.49n
BR3267	Close	2.02c-g	1.83d-i	2.43bcd	0.70mn
	Far	1.35h-m	1.29i-m	1.75e-i	1.85c-i

Means with the same letters are not statistically different (P>0.05)

**Table 7 Interaction effect of nitrogen sources, proximity to homestead and varieties on shoot dry weight of cowpea in soils from Chanchaga.**

Nitrogen sources	Proximity	Varieties			
		Kanannado	IT93K-452-1	IT97K-499-35	IT90K-277-2
Control	Close	2.64ab	1.70d-j	2.31abc	1.31h-k
	Far	1.54f-j	1.6le-j	2.07b-f	2.29a-d
Urea	Close	2.27a-d	2.21a-e	1.39g-k	1.12jk
	Far	2.71a	2.30a-d	1.98c-g	1.53f-j
BR3262	Close	2.29a-d	1.27ijk	1.43g-k	1.37h-k
	Far	1.30h-k	0.87k	1.64e-j	1.75c-i
BR3267	Close	1.54f-j	1.61e-j	1.18ijk	2.72a
	Far	1.89c-h	1.14jk	1.89c-h	1.69d-j

Means with the same letters are not statistically different (P>0.05)



**Figure 1: Linear relationships between symbiotic effectiveness (SE) of indigenous rhizobia and response to inoculation (RI) with BR3262 by cowpea varieties Kanannado, IT93k-452-1, IT97k-499-35 and IT90k-277-2 in soils sampled at sites close and far proximity to homestead.**

## REFERENCES

- Abaidoo, R.C., Keyser, H.H., Singleton, P.W., Dashiell, K.E., Sanginga, N. (2007). Population size, distribution, and symbiotic characteristics of indigenous Bradyrhizobium spp. that nodulate TGx soybean genotypes in Africa. *Applied Soil Ecology* 35: 57–67.
- Albareda, M., Rodríguez-Navarro, D. N., Camacho, M., & Temprano, F.J., (2008). Alternatives to peat as a carrier for rhizobia inoculants: Solid and liquid formulations. *Soil Biology and Biochemistry*, 40, 2771–2779, ISSN 0038-0717.
- Aliyu, I., Yusuf, A. & Abaidoo, R. (2013). Response of Grain Legumes to Rhizobial Inoculation in Two Savanna Soils of Nigeria. *African Journal of Microbiology Research*, 7, 1332-1342.
- Awonaike, K.O., Kumarasinghe, K.S. & Danso, S.K.A. (1990). Nitrogen fixation and yield of cowpea (*Vigna unguiculata* [L.] Walp) as influenced by cultivar and Bradyrhizobium strain. *Field Crop Research*, 24, 163 – 171.
- Cissé N, Hall A.E. Traditional Cowpea in Senegal, cas study 2003. [www.fao.org/ag/AGP/AGPC/doc/Publicat/cowpea\\_cisse/cowpea\\_cisse\\_e.htm](http://www.fao.org/ag/AGP/AGPC/doc/Publicat/cowpea_cisse/cowpea_cisse_e.htm) A review of soil and fertilizer use research in Nigeria. Federal Ministry of Agriculture
- Enwezor, W.O.I., Udo, E.J., Ayotade, K.A., Adepetu, J.A. & Chude, V.O. (1990). Literature review on soil fertility investigations in Nigeria federal Ministry of Agriculture and Natural resources, Lagos, 5, 281.
- GRDC (Grains Research and Development Corporation), Australia. 2013. Rhizobial inoculants fact sheet. Available at [www.coretext.com.au](http://www.coretext.com.au). January, 2013. <http://www.grdc.com.au/~media/B943F697AF9A406ABBA20E136FDB7DC4.ashx> Accessed on 24/9/2013.
- Hall, A. E., Cisse, N., Thiaw, S., Elawad, H. O. A. & Ehlers, J. D. (2003). Development of cowpea cultivars and germplasm by the Bean/Cowpea CRSP. *Field Crops Research*, 82, 103–134.
- Howieson, J. & Ballard, R. (2004). Optimizing the legume symbiosis in stressful and competitive environments within southern Australia - some contemporary thoughts. *Soil Biology and Biochemistry* 36, 1261-1273.
- IITA (International Institute of Tropical Agriculture). (1989). Selected methods for soil and plant analysis; Manual Series, No.



- 1 Revised Edition, 1979. IITA, Ibadan, Nigeria. 69.
- Mathu, S., Herrmann, L., Pypers, P., Matiru, V., Mwirichia, R., & Lesueur, D. (2012). Potential of indigenous bradyrhizobia versus commercial inoculants to improve cowpea (*Vigna unguiculata* L. walp.) and green gram (*Vignaradiata* L. wilczek.) yields in Kenya. *Soil Science.Plant Nutrition*. 58, 750–763. doi: 10.1080/00380768.2012.741041.
- O' Hara, G., Yates, R. & Howiesen, J. (2002). Selection of strains of root nodule bacteria to improve inoculant performance and increase legume productivity in stressful environments. In: D. Herridge (Ed.), *Inoculants and Nitrogen Fixation of Legumes in Vietnam*.
- Osunde, A.O., Gwam, S., Bala, A.,Sanginga,N. & Okogun,J.A. (2003). Response to rhizobial inoculation by two promiscuous soybean cultivars in soils of the southern Guinea savannah zone of Nigeria. *Biological.Fertilized Soils*, 37, 274–279. doi: 10.1007/s00374-0609-2.
- Sandman, W. P. L. (1970). *Practical aspects of Rhizobium bacteriology*. Rhodesian Ministry of Agriculture. 185.
- Subasinghe, S., Dayathilake, G.A. & Senarantne, R. (2001). Effect of inoculation and N application on growth, yield, nodulation and N fixation of cowpea (*Vigna unguiculata*). *Tropical Agricultural Research and Extension*, 12, 108 – 111.
- Thies, J. E., Singleton, P. W. & Bohlool, B. B. (1991). Influence of the size of indigenous rhizobial population on establishment and symbiotic performance of introduced rhizobia on field-grown legumes. *Applied and Environmental Microbiology* 38, 493 – 500.
- Vincent, J. M. (1970). *A manual for the practical study of root nodule bacteria*. International Biological programme handbook no 15 Blackwell Scientific Publ Ltd, Oxford, United Kingdom.
- Waddington, S.R. & Karigwindi, J. (2001). Productivity and profitability of maize plus groundnut rotations compared with continuous maize on smallholder farms in Zimbabwe. *Exp Agric* 37, 83–98.
- Woomer, P.L., Bennett, J., & Yost,Y. (1990). Overcoming the inflexibility of most probable number procedures. *Agronomy Journal*. 82, 349–353. doi: 10.2134/agronj1990.00021962008200020035x.
- Woomer, P.L., Huising, J. & Giller,K.E..(2014). *N2Africa Final Report of the First Phase 2009-2013*. Available at: www.N2Africa.org 138.
- Zilli, J.E., Marson, L.C., Marson, B.F., Rumjanek, N.G. & Xavier, G.R. (2009). Contribution of rhizobia strains to cowpea development and grain yield in Roraima – Brazil. *Acta Amazonica* 39(4), 749 – 758.
- Zingore, S., Murwira, H..K., Delve, R.J. & .E. Giller, R.J. (2007). *Field Crops Research*.

# BODY COMPOSITION AND NUTRIENT UTILIZATION OF *Clarias gariepinus* FINGERLINGS FED COOKED *Albizia lebbbeck* SEED MEAL

Orire<sup>1\*</sup>, A. M., O.J. ESTHER<sup>1</sup>

<sup>1</sup> Department of water resources, Aquaculture and Fisheries Technology

Federal University of Technology Minna, Niger State

\*Corresponding Author's E-mail: [abdul.orire@futminna.edu.ng](mailto:abdul.orire@futminna.edu.ng) GSM:

07032552295

## ABSTRACT

*Clarias gariepinus* fingerlings of average weight of 3.6g was used to evaluate the effect of cooked *Albizia lebbbeck* seed meal (CASM) on nutrient utilization and body composition of the fish. Three diets were formulated to contain 40% crude protein as thus, 0% CASM (diet 1) control, 50% CASM (diet 2) and 100% CASM (diet 3). The weight gain, specific growth rate (SGR), feed conversion ratio (FCR), protein efficiency ratio (PER), apparent net protein utilization (ANPU) were determined as growth indices with significant differences ( $P < 0.05$ ). Diet 2 (50% inclusion of cooked *Albizia lebbbeck* seed meal showed significantly ( $P < 0.05$ ) high values for the growth indices. Carcass nutrients composition also followed the same pattern with significant difference ( $P < 0.05$ ) to other diets while diet 1 performed significantly low ( $P < 0.05$ ). *Albizia lebbbeck* seed meal when boiled and at 50% inclusion has high potential of being utilized efficiently by *Clarias gariepinus* fingerlings without any adverse effect on its growth and body compositions.

**KEYWORDS:** *Clarias gariepinus*. *Albizia lebbbeck* seed meal. Growth indices.

## INTRODUCTION

The rise in the demand for animal protein has raised greater pursuit in the production of fast growing animals (fish) (Obinne and Okorie 2008). *Clarias gariepinus* is a fast growing species of Africa catfish that are commonly raised to provide meat for human consumption. However, the rising cost of fish feed has continued to be a concern in fish farming. This is because the feed alone account for about 70% of the total production (Olorede and Longe, 1999). This high

ingredients are limitation to commercial fish production in Nigeria (Olorede and Aiavi, 2005).

There exist some leguminous plant which are underutilized but have pronounced capabilities of been advanced into fish feed. One of such is *Albizia lebbbeck*. However, there is a prerogative of toxicity in the seed (Olorede and Ajayi, 2005). There is therefore the need for processing before usage.

cost combined with lack of enough knowledge of potential unconventional and low cost

## METHODOLOGY

Matured and dried pods *Albizia lebbek* fruit were plucked from the trees in around Bosso campus Federal university of Technology minna. The pods were cooked at 60°C for 45 minutes and further dried in the air for 3 hours and then manually crushed with hammer miller.

### Experimental Fish

Ninety *Clarias gariepinus* fingerlings were produced from Eco Rehab Environmental Centre Kuje Fish Farm

Hatcheries and transported in 50 liter jericin to the laboratory for one week acclimatization. They were fed commercial feed . before the experiment commenced. Six plastic bowls were filled with bore hole water and stocked with 15 fingerlings which were weighed at the commencement of the feeding trial.

### Feeding rate and management

The fish feeding rate was commenced at 3% body weight but was adjusted and fed three times daily. However, the quantity of ration was adjusted fortnightly to reflect weight increase and feed consumption. The bowls were cleaned and fecal water were siphoned out before morning feeding. The bowls were cleaned weekly to maintain good water quality medium. The water temperature, pH, conductivity and dissolved oxygen were monitored on weekly basis with the aid of appropriate water quality meters.

### Fish growth and evaluation

Growth performance and diet nutrient were analyzed in terms of mean weight gain (MWG), final weight gain (FWG) feed conversion ratio (FCR), specific growth rate (SGR), protein efficiency ratio (PER) and apparent net protein utilization (ANPU).

### Experimental Diets

Three diets containing varied treatments of *Albizia lebbek* were formulated at 0%, 50% and 100% inclusion levels. Diets were formulated using Pearson Square Method to obtain the formulated crude protein level as shown in Table 1

### Statistical analyses

Data were analyzed using one -- way analysis of variance (ANOVA) using statistical 6.0 (stat soft, Inc., USA). Difference between treatments were compared by turkey's test. Level of significance was tested at  $P < 0.05$ .

## RESULTS AND DISCUSSION

The results showed that the values of water quality parameter measured in the contexts of the experimental period did not vary significantly ( $p > 0.05$ ) with each other, the water temperature in all the treatments ranged from 25 -28°C. Dissolved oxygen ranged from

5.8mg/l – 8.5mg/l, pH from 6.25 to 7.95 and conductivity from 264 to 331. There was no significant difference among treatments as values obtained were within the acceptable and optimum range for fish culture (Omitoyin, 1995; Swann, 2006; Madu *et al.*,

2001). The growth parameters showed that fish fed with 50% inclusion (Diet 2) of cooked *Albizia lebbek* seed meal had the highest value of all growth performance and was significantly different from other treatment ( $P < 0.05$ ). this could be attributed to the

palatability of the diet (Riche *et al.*, 2001; Ahmed,

2008). However, fish fed 100% inclusion of cooked *Albizia lebbek* seed meal and 0% inclusion of cooked *Albizia lebbek* seed meal (Diet 1) are not significantly different ( $P > 0.05$ ) from each other. This could be as a result of the varying inclusion level of *Albizia lebbek* seed meal Watanabe *et al.* (1987). The protein efficiency ratio (PER) and specific growth rate (SGR) of *Clarias gariepinus* fingerlings fed 0% and 100% *Albizia lebbek* cooked seed meal are not significantly different ( $P > 0.05$ ) than each other but are significantly different ( $P < 0.05$ ) from 50% inclusion of cooked *Albizia lebbek* seed meal. Mean final weight (MFW) and feed conversion ratio (FCR) and apparent net protein utilization (ANPU) showed the same trend with



50% inclusion cooked *Albizia lebbbeck* seed meal with significant difference ( $P < 0.05$ ). There was a significant difference ( $P < 0.05$ ) in the survival of *Clarias gariepinus* fingerlings fed with 50% CALSM having

46% survival rate followed by diet 3 (100% CALSM)

40% while 0% CALSM had 33% survival rate.

The crude protein of the experimental fish in all treatment was significantly different from value obtained in the initial proximate composition of the experimental fish before the feeding trial commenced as shown in Table 3. The experimental diets resulted in higher protein, lipid and decreasing moisture in the experimental fishes compared to initial body composition analysis. However the crude ash content in the final body composition of the experimental fishes decrease with increased inclusion level of cooked *Albizia lebbbeck* seed meal. The moisture content in the final body composition follows the same pattern with that of ash. Fishes fed diet 2 (50% CALSM) had the highest protein retention in the body mass of the experimental fishes which is significantly different from other treatments. However, 0%, and 100% inclusion level CALSM protein retention in the final body composition of the experimental fish are not significantly different from each other. Lipid content of the carcass analyzed showed that diet 1 (0% CALSM) had the highest lipid content which was significantly different from other inclusion levels. While diet 2 (50% CALSM) and diet 3 (100% CALSM) are not significantly different from each other. This compared favourably with findings of Burges (1989), although lower than Kaga (1999) but higher than Alegbeleye *et al.* (2004).

From the result obtained in this study, it can be concluded that fingerlings of *Clarias gariepinus* can make use of cooked *Albizia lebbbeck* seed meal under good processing and cooking method at an inclusion level of 50% in their diets to give excellent performance in growth, nutrient utilization and body composition without any adverse effect on their health and morphological structure. However, the increase in the inclusion level of *Albizia lebbbeck* in the diet may also have contributed to a higher accumulation of carcass lipid. For effective utilization of cooked *Albizia lebbbeck* seed meal and inclusion level beyond 50%, a longer feeding trial and further research work on the amino acid profile should be looked into.

## CONCLUSION AND RECOMMENDATIONS

Table 1: Diets formulated and their proximate compositions

Ingredients (%)	Diet 1	Diet 2	Diet 3
	0% CALSM	50% CALSM	100% CALSM
Soybean Meal	780.20	404.80	0.00
CASM	0.00	404.80	704.10
Maize Meal	79.80	48.20	155.90
Shear butter Oil	90.00	90.00	90.00
Vitamin Premix	50.00	50.00	50.00
Total	1000.00	1000.00	1000.00
<b>Proximate Compositions of Formulated Diets</b>			
Moisture (%)		4.5	5.5
Crude protein (%)		40.6	40.25
Crude lipid (%)	10.5	10.3	10.2
Ash (%)		4.5	7.5
Crude fibre (%)		0.5	1.9

Table 2: Growth parameter of *Clarias gariepinus* fingerlings fed cooked *Albizia* lebbeck seed meal

Growth Parameter	Diet 1	Diet 2	Diet 3	SD±
Initial weight gain (g)	3.64 <sup>a</sup> ±0.04	3.63 <sup>a</sup> ±0.14	3.66 <sup>a</sup> ±0.00	0.02
Final weight gain (g)	7.41 <sup>b</sup> ±1.67	8.54 <sup>a</sup> ±0.35	7.73 <sup>b</sup> ±0.72	1.07
Mean weigh gain (g)	3.78 <sup>b</sup> ±1.63	4.92 <sup>a</sup> ±0.36	4.07 <sup>a</sup> ±0.73	1.05
Feed conversion ratio	0.76 <sup>a</sup> ±0.28	0.66 <sup>a</sup> ±0.04	0.76 <sup>a</sup> ±0.13	0.18
Specific growth rate (%)	1.25 <sup>b</sup> ±0.39	1.53 <sup>a</sup> ±0.08	1.33 <sup>b</sup> ±0.17	0.25
Protein efficiency ratio	3.34 <sup>b</sup> ±1.18	3.83 <sup>a</sup> ±0.19	3.31 <sup>b</sup> ±0.54	0.76
Apparent net protein utilization	2.05 <sup>b</sup> ±0.68	2.41 <sup>a</sup> ±0.08	2.05 <sup>b</sup> ±0.33	0.44
Survival rate (%)	33.33 <sup>c</sup> ±0.00	46.67 <sup>a</sup> ±0.00	40.00 <sup>b</sup> ±0.00	0.00

Table 3: Proximate composition analyses of whole body *C. gariepinus* fingerlings (dry basis) fed experimental diets for 56 days

Component (%)	Initial	Final carcass			
		Diet 1	Diet 2	Diet 3	SD±
Protein	57.75 <sup>c</sup>	59.68 <sup>b</sup> ±0.25	60.82 <sup>a</sup> ±0.62	59.98 <sup>b</sup> ±0.04	0.38
Lipid	12.26 <sup>b</sup>	13.25 <sup>b</sup> ±0.78	12.13 <sup>a</sup> ±0.15	12.58 <sup>b</sup> ±0.49	0.54
Ash	14.52 <sup>a</sup>	13.62 <sup>b</sup> ±0.28	13.37 <sup>a</sup> ±0.57	13.18 <sup>b</sup> ±0.54	0.4
Moisture	15.45 <sup>d</sup>	13.70 <sup>b</sup> ±0.39	12.82 <sup>b</sup> ±0.88	14.33 <sup>a</sup> ±0.01	<sup>s</sup> 0.56

Values in the same row with different superscripts are significantly different (p<0.05) from each other

#### REFERENCES

- Ahmed, M.H., (2008). Evaluation of gambusia, *Gambusia affinis*, fish meal in practical diets for fry Nile tilapia, *Oreochromis niloticus*. *Journal of World Aquaculture Society*.39, 243-250.
- Atteh, J.O., (2004). Theory and practices of poultry production. First ed., Adeleke printers, Ilorin, Nigeria, pp: 1-3
- Burgess, W.E. (1989). An atlas of freshwater and marine catfishes. A preliminary survey of the Siluriformes. T.F.H. Publications, Inc., Neptune City, New Jersey (USA). 784 p. groundnut cake with rubber seed cake in diet for Nile Tilapia. *Journal of Aquatic*
- Kaga, B. I. (1999). Dietary potentials of *Albizzia*, *Adansonia*, *Delonix* and *Sesamum* seed protein for maintenance of laboratory mice. M.Sc. Thesis, Ahmadu Bello University, Zaria. P. 24.
- Madu, C.T., Sogbesan, O.A. and Ibiyo, L.M.O. (2003). Some non-conventional fish feed resources in Nigeria. In: A.A Eyo (Ed.), *Proceeding Joint FISON NIFFR/SPFS National workshop on fish feed and feeding practices in Aquaculture held. National Institutes for Freshwater fisheries Research*, 15<sup>th</sup> – 19<sup>th</sup> September, 2003. *New-Bussa*: 73-82.
- Obinne, J. I. and A.U. Okorie, (2008). Effect of different crude protein and digestible energy levels on the growth preference of rabbits in the tropics. Nigeria. *J. anim. Prod*; 35: 210 –216
- Oloredo, B.R. and A. F. Ajayi, (2005). Replacement of groundnut cake and maize with falderal *Albizzia* GOA in the diets of broiler chickens. *Bull. Anim. Hlth. Prod. Afr.*, 53: 61 – 67.
- Oloredo, B.R. and O.G. Longe, (1999). Growth, nutrient retention, heamatology and serum chemistry of pullet chicks fed sheabutter cake in the humid tropic. *Arch. Zootech*; 49:



441 – 444 *Science*. Vol. 19 (1) 27 – 30.

Omitoyin, B.O., (1995). Utilization of poultry by products (feathers and offal) in the diets of African Catfish *Albizia lebbeck* (Burchell). Ph. D. Thesis, University of Ibadan, Ibadan, Nigerial. 219.

Riche, M., Trottier, N.L., Ku, P.K., Garling, D.L., (2001). Apparent digestibility of crude protein and apparent availability of individual amino acids in tilapia (*Oreochromis niloticus*) fed phytase pretreated soybean meal diets. *Fish Physiol. Biochem.* 25, 181-194.

Swann, L., (2006). A fish farmer's guide to understanding water quality. The Illinois- Indiana sea grant program Purdue University. Retrieved from <http://aquanic.org/publicat/state/il->

[in/as-503.htm](http://aquanic.org/publicat/state/il-in/as-503.htm) 20th February, 2006

Watanabe, T., (1988). Fish Nutrition and Matriculture. In: The General Aquaculture course (Ed.: Watanabe, T.). Kanagawa International Fisheries Training Centre, Japan International Cp-operation Agency (JICA), Tokyo. 233p.



# AGROCHEMICAL SAFETY AND HEALTH INFORMATION USAGE AMONG FARMERS IN NIGERIA.

Jibrin, S.<sup>1</sup>, O.J.Ajayi<sup>1</sup>, I.T. Salihu<sup>1</sup>, L. Y. Bello and A. Umar<sup>3</sup>

<sup>1</sup>Department of Agricultural Extension and Rural Development, F.U.T. Minna

<sup>2</sup>Department of Crop Production Technology, F.U.T. Minna

<sup>3</sup>Department of Agricultural Economics and Extension Services, IBBU Lapai

\*Corresponding Author's E-mail: [safil4real@gmail.com](mailto:safil4real@gmail.com), GSM: [07030648457](tel:07030648457)

## ABSTRACT

*The need to increase and improve the quantity and quality of farm produce has led to increase use of agrochemical by both small and large scale farmers. However, there are other corresponding cost brought about by an increase dependence on agrochemical among which include harmful effects on human health and environment. Illegal marketing of agrochemical, low illiteracy level and poor understanding of safety and health information are some of the greatest challenges in the use of agrochemical. Information is said to be "Power" and as such the adherence to agrochemical safety and health information (product label) will no doubt help to reduce the incidence of agrochemical hazards as meeting the minimum necessities of occupational health standards is viewed as one of the most important components of sustainable agricultural development.*

**Keywords:** Agrochemical, Safety and health information, Farmers

---

of improved farm inputs like agrochemical (United Nations, (UN) 2015).

## INTRODUCTION

The need to feed the ever increasing population in the world has been one of the major issues especially in the third world countries who are backwards in terms of modern agriculture. The United Nation Population Division (UNPD) (2007) has reported that the World has witnessed population growth over the last 100 years by nearly fourfold and it is projected to increase from 6.7 billion to 9.2 billion by the year 2050. Consequently, the demand for cereal is expected to increase by almost 50 % by 2030 (Food and Agriculture Organization (FAO), 2007). The decrease in food production can be attributed to the effect of flooding, desert encroachment, climate change and increase in conflict which has paralyze food production and has dislocated millions of refugees. However, increase in food production cannot be achieved without the use

Maize has been regarded as one of the most important cereal in the world as a result of its high economic importance and numerous uses (for domestic consumption in addition to its industrial use by flour mills, breweries, confectioneries and animal feed manufacturers). In the world, it is ranked third after rice and wheat, also in Nigeria it is one of the most important cereal crops especially in the middle belt of Nigeria (Offiah, 2015). As a result of its high demand, maize is gradually becoming less affordable for poor consumers, thus the need for its increase production can never be over emphasized and invariably, the use of agrochemical will also increase (Badmus *et al.*, 2011).

Agrochemical implies all chemical products which are manufactured or processed for use at work in agriculture and agro-allied industries to increase productivity and control pest and diseases (Omari, 2014). It encompasses fertilizers, pesticides (herbicides, insecticides, rodenticides, and fungicides) and plant regulators. In bid to control maize pests such as stem borers, armyworms, silkworm and weevils, weeds and maize diseases

such as downy mildew, maize rust, leaf blight and leaf spot for improvement in productivity, maize farmers have over the years resorted to the use of agrochemical. Mc Arthur and Mc Cord (2014) reported that agrochemical increase crop yield which leads to economic growth. The use of agrochemical for crop production has been on the increase and an estimated 2.5 million tonnes of pesticides are applied to agricultural crops worldwide each year (Nnamonu and Onekutu, 2015). In Nigeria, an estimated amount of 125,000-130,000 metric tonnes of pesticides is applied each year (Aderonke, *et al.* (2017) and Asokwa and Galvin, 2009).

However, FAO has caution farmers on the excessive application of agrochemical as these can increase the risk of having residue in crops and farm environment. Zia, *et al.* (2010) in Ajmer, *et al.* (2017)) reported that residue of cereals showed that wheat contained the highest concentration of tested agrochemical than maize and rice while maize contained a much higher concentration of agrochemical than rice. According to World Health Organization, each year, about 3,000,000 cases of agrochemical poisoning and 220,000 deaths are reported in developing countries (Lah, 2011). Furthermore, about 2.2 million people, mainly belonging to developing countries are at increased risk of exposure to pesticides (Hicks, 2013). Children may also be exposed to agrochemical through forms of hazardous child labour involving fieldwork, spraying agrochemical or washing their parents' contaminated work clothes.

Safety refers to the state of being protected from agrochemical related hazards. Safety and health practices and/or information on agrochemical therefore seeks to identify a product and describes how, where and when it should be used. It is then complimented with details of potential hazards, good practices, safety precautions, first aid instructions and advice to health personnel (International Labour Organization, (ILO), 1991). Before using any agrochemical it is always recommended that the user read, understand and comply with the safety and health practices/information.

### **Agrochemical**

Agrochemical implies all chemical products which are manufactured or processed for use at work in agriculture and agro-allied industries to increase productivity and control pest and diseases (Omari, 2014). It encompasses fertilizers, pesticides (herbicides, insecticides, rodenticides, and

fungicides), and plant regulators. In bid to control maize pests such as stem borers, armyworms, silkworm and weevils, weeds and maize diseases such as downy mildew, maize rust, leaf blight and leaf spot for improvement in productivity, maize farmers have over the years resorted to the use of agrochemical. Alexandratos and Bruinsma, (2012) reported that agrochemical include pesticides, herbicides, fertilizers and diesel fuel or disinfectant products and are commonly found on farms in rural communities. Agrochemical during the last century general, became an essential element of worldwide agriculture systems, therefore paving way for an obvious increase in crop yields and food production.

### **Awareness on Agrochemical Safety and Health Practices/Information among Farmers**

Gobusamng *et al.* (2012) reported that all of the farmers interviewed (100 percent) said that they read and followed the directions on the pesticide containers. Mustapha *et al.* (2017) reported that Kuwaiti farmers' level of understanding of agrochemical safety practices is insufficient as over 70 percent of them did not read or follow pesticide safety and health information. Clyde *et al.* (2012) recommended that before handling, compounding, packing or applying any pesticides, users should read the product safety and health instructions carefully. Reading and adhering to instruction among farmers usually help to reduce hazards associated with the use of agrochemical.

### **Methods use to Disseminate Safety and Health Practices/Information**

Methods used to relay agrochemical safety and health information changes with change in farmers socio-economic characteristics. Educational resources usually serve as an important guide in encouraging farmers and their families to comply with safety instruction and practice which will help change their attitude when handling agrochemical (Shari *et al.*, 2017). Over the years, researchers had come to find out that various farmer characteristics are in line with preferred information sources. A study on the preferred information sources of cotton farmers who use agrochemical revealed that majority of the



farmers rely on extension resources and they tend to be younger, have big farms, higher incomes, and rent larger proportions of land as compared to other groups (Velandia *et al.*, 2010). Shari *et al.* (2017) reported that internet, social media, and e-mail messaging are the most preferred sources of information for farmers that are less than 35 years of age as compared to the older farmers. Farmers with ages greater than 56 years prefer local papers as a source of farm safety and health practices/information while farmers with age less than 35 years attend kids' safety events and school programs more than older farmers. The authors also reported that younger and middle aged farmers prefer using informational websites significantly more than older farmers.

Furthermore, farmers who received 76–100 percent of their incomes from farming were more likely not to use information from the educational materials as oppose to farmers who received 26–75percent of their incomes from farming. Materials that encompassed general or simple languages were mostly preferred over those that have technical terms. Photographs or a combination of photos, drawings, and cartoons were preferred visual images. Materials signifying lifelike, easy-to-use approaches and materials directed at youths and children were favorite over materials listing applicable protective equipment. Images showing familiar farming practices and useful prevention strategies inspire use of resources.

### **Training on Use/Handling of Agrochemical**

Franklin *et al.* (2017) reported that there have been cases where farmers over apply agrochemical than the recommended quantities or repeatedly application per season as a result of the fact that a good number of the farmers in the country cannot read, lack basic and formal training on agrochemical handling and recommended personal protective equipment. Chemicals that have been washed from sprayed farms usually contaminate food crops and even spread to affect water bodies. The problem usually becomes more serious when farmers wash their knapsack sprayer and clothes in water bodies during and after spraying. Gitahi (2014), reported that training of farmers on proper handling of agrochemical handling was low with only 17 percent having been trained on pest control, 3 percent each for agrochemical hazards on environment and human

health, 0.2 percent on fertilizer use knowledge and 69 percent having had no training

### **Entry route of Agrochemical into Human Body**

Wolfe (1973) and Iyagbe (2013) indicated that over 97 percent of agrochemical to which the body is subjected to during possible exposure situations is deposited on the skin Requena, (2009) and Kesner *et al.* (2015) on the other hand reported that dosage, the time and duration of spraying, the route of entry into the body, the chemical composition and genetic properties are the major factors that determine the levels of hazards associated with the use of agrochemical. Clyde *et al.* (2012) reported that agrochemical can get into the body through three major ways;

- Through the mouth (orally), by breathing into lungs (inhalation) and most common and by absorption through the skin or eyes (dermally)

Toxicology Information Brief (1993) reported that a compound, such as chloroform, which dissolves promptly and can be found in drinking water are ways that people can unknowingly consume agrochemical. At the point when this water is utilized for drinking, ingestion becomes the course of exposure. When it is utilized for showering, introduction may happen because of inward breath of the steam or fog and from coordinate contact through the skin. Similarly, agrochemical can easily get into the human system through many ways or through more than one route if precautions are not taken. An agrochemical which is sprinkled can be breathed in, have direct contact with the skin when mixing or application and be ingested through nourishment if hands are not properly washed before eating. The entry route of agrochemical into human body are discussed categorically below.

#### **Through the mouth (Orally)**

Lack of proper personal hygiene (washing of hands) can cause impurity on the lips and mouth or accidental swallowing of agrochemical. Also, it is dangerous to blow blocked sprayer nozzles in an attempt to clean it (ILO, 1991). Chemicals that mistakenly get into the mouth and are gulped don't generally harm the gastrointestinal tract itself except if they are chafing or destructive (ILO, 1991). Shetty

*et al.* (2011) also opined that consumers may be affected by relatively low amounts of agrochemical residues in drinking water and through food products (long-term effects) or acutely through high doses caused by misuse, wrong application or overdose at the farm level.

### **Inhalation (By breathing into lungs)**

Agrochemical that are in form gases, fine spray droplets, dust, fumes and smoke are often been breathed into the lungs while gases mixed with the air tend to remain suspended in the air for some time after release this is because these particles are so small or well dispersed that they cannot be seen International Labour Organization, (ILO), (1991). Spraying agrochemical without adequate precautions is noted to be a common cause of poisoning by inhalation.

Toxicology Information Brief (1993) reported that inhalation is the major route of entry of agrochemical that are in form of vapors, gases, mists or particulates. Once inhaled, agrochemical are either exhaled or deposited in the respiratory tract. If deposited, damage can occur through direct contact with tissue or the chemical may diffuse into the blood through the lung-blood interface. Upon contact with tissue in the upper respiratory tract or lungs, agrochemical may cause serious health impairment ranging from simple irritation to severe tissue destruction. Substances absorbed into the blood are circulated and distributed to organs that have an attraction for that particular chemical. Health effects can then occur in the organs, which are sensitive to the toxicant.

### **Skin absorption (or eye)**

Agrochemical absorbing through the skin is one of the most common poisoning routes. Pesticides usually kill pest by penetrating the insect's skin or surfaces of plants considered to be weeds. Therefore, these substances can easily penetrate the intact human skin, if allowed to do so. Some formulations that are toxic and contain penetrative solvent like petroleum products, xylene or kerosene are usually are hazardous to human. These substance can penetrate through the farmers cloth unnoticed(ILO,1991).

### **Injection**

Injection which is another way agrochemical gets into the body occurs when a substances enter the body when the skin is penetrated or punctured by contaminated objects. Impacts would then be able to happen as the substance is coursed in the blood and saved in the objective organs.

### **Perceived Health Hazards Associated with the use of Agrochemical**

As a result of about 2 million tonnes of waste (industrial wastes, chemicals, human waste and agricultural wastes such as fertilizers, pesticides and pesticide residues) that are been dumped into water bodies each day, several water bodies have been rendered unfit for both primary and/or secondary usage (United Nations Educational, Scientific and Cultural Organization (UNESCO) (2003)). Almaszabeen *et al.* (2018) reported that about 9.16 percent of cocoa farmers strongly agreed and 81.16 percent agreed that the pesticide use cause effects on human health. Also, Mustapha *et al.* (2017) reported that a significant number (82 percent) of Kuwaiti farmers reported at least one symptom of acute poisoning immediately after applying or handling agrochemical, while 18 percent of respondents did not attribute any health problem encountered to agrochemical exposure. The most frequently reported symptoms were headaches (82 percent), skin irritation (58 percent), nausea (49 percent), itchy eyes (79 percent), dizziness (41percent), fatigue (50percent), and coughing (22percent). Other symptoms reported by respondents were poor vision, stomach ache, excessive sweating, shortness of breath and vomiting. When respondents were asked what action they took following an incident of poisoning, about 75percent reported taking no action as the incident was minor or required only self-medication (chewing of cola nut). Only 5percent of respondents reported a serious poisoning incident that required medical attention in a hospital.

Agrochemical pollute water bodies thus making it unsafe for human use e.g. drinking, washing of farm produce, etc.The negative impact on human health and the environment by the use of agrochemical has not been known, especially, by farmers. The excessive use of agrochemical more than the



recommended quantity by farmers was as a result of advertisement from chemical sale agents. Many of the agrochemical used are persistent soil contaminants, which can stay for decades in the soil without decaying and in the long run affect soil conservation (Van der Werf 1996). Death as a result of agrochemical related poisoning are often caused by using agrochemical packages or containers after they are emptied of contents. Low literacy level, poor reading culture of agrochemical labels and sometimes lack of understanding of the agrochemical label are some of the reason why people still use empty container of agrochemical to store food and water.

Agrochemical that are applied to crops can volatilize and may be blown by winds into nearby areas, potentially posing a threat to wildlife (Sequoia and Kings, 2007). More importantly, the remains of these agrochemical are washed into streams which might serve as a source of drinking water for human and animals thus resulting to one ailment or the other depending on the concentration. The use of agrochemical without wearing personal protective equipment creates substantial health impacts in all parts of the World. Agrochemical effects can be divided broadly into two categories: Acute effects, which appear immediately or very soon after exposure and Chronic effects, which may manifest themselves many years later and whose origins are often difficult to trace.

### **Safety Measure employed in the use/ Handling of Agrochemical**

Agrochemical popularity has led to its extensive use and as such, there are serious concerns about health risks arising from the exposure of farmers when mixing and applying agrochemical or working in treated fields and from residues on food and in drinking water for the general population. The place and time of application to some extent influences the type of health symptom that manifests. The exposure of workers increases in the case of not paying attention to the instructions on how to use the agrochemical and particularly when they ignore basic safety guidelines on the use of personal protective equipment and fundamental sanitation practices such as washing hands after agrochemical handling or before eating (Damalas *et al.*, 2011).

In general, the way in which agrochemical are applied has a strong bearing on the extent of

agrochemical hazard on farmers. For example, leaks from joints in the application equipment may often cause farmers to come into direct skin contact with large amounts of agrochemical. Similarly, blocked or unsuitable nozzles of the spraying equipment affect the quality of application and increase the degree of exposure. Damalas *et al.* (2011) further stressed that agrochemical absorption through the respiratory tract is largely supported by changes in wind speed and direction during spraying. Also application on extremely hot and dry days promotes agrochemical drift and increases exposure while, spraying in poorly ventilated spaces, such as greenhouses, expose farmers to inhalation and absorption by skin of high concentrations of agrochemical. Spraying from the air can create a risk for farmers who are not involved in the operation, the population at large, food products left in the open and the environment as a whole. All the listed situations, which are common during agrochemical application, may result in direct and prolonged exposure of farmers to pesticides and may affect their health.

Mustapha *et al.* (2017) reported that protective measures during and after agrochemical application are important to reduce exposure to them. The author further reported that 58 percent of the farmers did not use any PPE when mixing or spraying pesticides. When respondents were asked to indicate the main reasons for not using PPE, lack of availability when needed (35 percent) and PPE being uncomfortable in the local hot and humid climate (90 percent), too expensive (65 percent) and slowing you down (29 percent) were the most reasons cited. Respondents (6 percent) also cited not experiencing any health problems from using pesticides as reason for not using PPE. Among respondents who reported using PPE, less than 5 percent wore all the recommended six key PPE items (coveralls, protective boots, glasses/goggles, gloves, respirator, and hat) as recommended by ILO (1991).

### **CONCLUSION**

Although agrochemical has a lot of benefit in terms of increasing output and protecting crop, but the benefit are far been outweighed by several health and environmental challenges due to their indiscriminate use. Literatures have shown that farmers even when literate do not usually read and follow manufactures instruction that are on the label hence the high



incidence of agrochemical poisoning. Moreover, accumulation of agrochemical residues in food grains and vegetables is as a result of their excessive use. However, the impact of agrochemical hazards on human /environment and residues on crop can be minimized by adhering to manufactures instruction and observing personal hygiene.

## REFERENCES

Aderonke O. O., Oluwatoyin T. F., Latifat M. A.,

Damilola E. F. & Muyideen O. M., Human. (2017). Health Risk of Organochlorine Pesticides in Foods Grown in Nigeria. *Journal of Health and Pollution*. 7(15), 63-70.

Ajmer, S. G., Ashish S., Pradeep, K. & Jagdeep, S. D.

(2017). Pesticide Residues in Food Grains, Vegetables and Fruits: A Hazard to Human Health. *Journal of Medicinal Chemistry and Toxicology*. 1 (2)534-540.

Alexandratos, N. & Bruinsma, J. (2012). World agriculture towards 2030/2050: the 2012 revision. ESA Working paper No. 12-03. FAO, Rome.

Almaszabeen, B. & Uma Dev K. (2018). Perception of Cotton Farmers on the Effects of Pesticide

Use. *Asian Journal of Agricultural Extension, Economics and Sociology*. 1 (23), 1-6.

Asokwal, M.J. and Galvin, J.R. (2009). Safe application of pesticides and herbicides. Connecticut Department of Public Health Environmental and Occupational Health Assessment Program.

<http://www.ct.gov/dph>

Badmus, M.A. & Ariyo, O.S. (2011): Forecasting

Cultivated Areas and Production of Maize in Nigerian using ARIMA Model. National Horticultural Research Institute, Jericho Idi

Ishin, Ibadan, Nigeria. *Asian Journal of Agricultural Sciences*. 3(3), 171-176.

Clyde, L. O, Eric, C. B., Jan R. H. & Pierce, J. H.

(2012). Protective clothing and equipment for Pesticides. Nab guide. University of Nebraska Lincoln Extension Institute of Agricultural and Natural Resources.

Damalas, C. A. & Eleftherohorinos, I. G. (2011).

“Pesticide Exposure, Safety Issues, and Risk Assessment Indicators” *International Journal of Environmental Research and Public Health*. 8, 1402-1419.

Damalas, C. A. & Hashemi, S.M. (2010). Pesticide

risk perception and use of personal protective

equipment among young and old cotton growers in Northern Greece. *Agrociencia*. 44, 363-371.

Food and Agricultural Organizations (FAO)

(2007). The State of Food Insecurity in the World.

Franklin, M. N, Kwadwo, T. & Gideon, D. (2017).

Awareness of Health Implications of Agrochemical Use: Effects on Maize Production in Ejura-Sekyedumase Municipality,

Ghana. *Journal of Advances in Agriculture*. <https://doi.org/10.1155/2017/7960964>

Gitahi, M. W. (2014). Risk of agrochemicals on the

environment and human health- in Mukaro location, Nyeri County, Kenya.(Bsc. Agric). Retrieved on 6<sup>th</sup> January 2018.

Gobusamng, L., Motshwari. O., Otsoseng O., Mogapi,

E. M. & Yoseph, A. (2012). Urban Vegetable Farmworkers Beliefs and Perception of Risks Associated with Pesticides Exposure: A Case of Gaborone City, Botswana. *Journal of Plant Studies*. (1)2, 114-119.

Hicks B (2013) Agricultural pesticides and human health. In: National Association of Geoscience Teachers. Available from [http://serc.carleton.edu/NAGTWorkshops/health/case\\_studies/pesticides.html](http://serc.carleton.edu/NAGTWorkshops/health/case_studies/pesticides.html). Accessed July 21, 2018.

Lah, K. (2011) Effects of pesticides on human health. In: Toxipedia. Available from <http://www.toxipedia.org/display/toxipedia/Effects+of+Pesticides+on+Human+Health> . Accessed September 7, 2018.

Mc Authur, J. W. & Mc Cord, G.C. (2014). "Fertilizer growth: Agricultural inputs and their effects in economic development. 'Global Economy and development Working Paper No. 77. Booking Institute: Washington, DC.

Mustapha, F. A., Jallow, D. G. Awadh, M. S. Albaho, V. Y. D., Binson M. Thomas, Mohamed-B. & Ashour, A. (2017). Pesticide Knowledge and Safety Practices among Farm Workers in Kuwait: Results of a Survey. *International Journal of Environmental Research, Public Health*. 14(4), 340-351.

International Labour Organization (ILO) (1991).

Safety and Health in the use of agrochemical; A Guide Geneva.

Iyagba, G. A. (2013) Assessing the Safety Use of Herbicides by Horticultural Farmers in Rivers State, Nigeria. *European Scientific Journal*, 9(5), 65-70.

Kesner, D. & Pierre, T. (2015) Agrochemicals and their impact on human health. An analysis of Pesticide use and incidences of diseases in the region of Rincón de Santa María. 17

Nnamonu, L. A. & Onokutu, A. (2015). Green Pesticides in Nigeria: An Overview. *Journal of Biology, Agriculture and Healthcare*. 5(9), 48-62.

Offiah, E. O. (2015). Sustainability of Maize-based Production system in Anambra State Nigeria. M.sc Thesis submitted to the Department of Agricultural Economics, University of Nigeria, Nsukka, in partial fulfilment of the requirement for the award of a degree of Master of Science in Agricultural Economics.

Omari, S. (2014). "Assessing Farmers' Knowledge of Effects of Agrochemical use on Human Health and the Environment: a case study of Akuapem South Municipality, Ghana,"

*International Journal of Applied Sciences and Engineering Research*. 3(2), 87-92.

Requena, J. (2009). Problemas toxicológicos

generados por el uso de las principales familias de plaguicidas en Panamá. Herramientas de control. (Retrieved 5<sup>th</sup> January 2018).

Shari, B., Ellen, D. & Mary, W. (2017). What Influences Farmers to Use Farm Safety and Health Information? *Journal of Extension*. (55)1,765-773.

Shetty, P. K., Hiremath, M. B. Murugan, M. & Nerli, R. B. (2011). Farmer's health externalities in pesticide use predominant regions in India. *World Journal of Science and Technology*. 1(4), 01-11

Toxicology Information Brief (1993). Entry and Fate of Chemicals In Humans. Extension Toxicology Network.

United Nations Educational, Scientific and Cultural Organization .UNESCO (2003). Water for People, Water for Life: UN World Water Development Report (WWDR), Paris, United Nations Educational, Scientific and Cultural Organization.

United Nations Population Division (UNPD) (2007). Annual Report 2007. *Engineering*. 4(12).

United Nations (UN) (2015). Department of Economic

and Social Affairs, Population Division

(2015). World Population Prospects: The 2015 Revision, Key Findings and Advance Tables. Working Paper No. ESA/P/WP.241. United Nations New York, 2015

Van der Werf H. M.G. (1996): "Assessing the impact of pesticides on the environment". *Journal of Agricultural Ecosystem and Environment*. 60, 81 – 96.

Velandia, M., Roberts, R. K., Martin, S. W., Lambert,

D. M., Larson, J. A., Jenkins, A., & English,

B. C. (2010). Precision farming information sources used by cotton farmers and implications for Extension. *Journal of Extension*. 48(5), 256-264.

Wolfe, K. (1973). Minimizing pesticide contamination. In: Akobundu, I. O. (ed.) *Weed Science in*

*the tropics. Principles and practices*. Connecticut. A John Wiley and Sons Publication. 318-334.

Zia, M.S., Khan, M.J. & Qasim, M., (2010). Pesticide Residue in the Food Chain and Human Body inside Pakistan. *International Journal of Environmental and Ecological En*



## GROWTH PERFORMANCE AND NUTRIENT DIGESTIBILITY OF BROILER CHICKENS FED DIETS CONTAINING SHEA BUTTER CAKE FERMENTED WITH *Aspergillus niger*

Ewa<sup>1\*</sup>, E. C., E. Z. Jiya<sup>2</sup>, O. A. Amao<sup>3</sup>, A. D. Ojo<sup>4</sup>

<sup>1,2,3,4</sup> Department of Animal Production, School of Agriculture and Agricultural Technology,  
Federal University of Technology, P. M. B. 65 Minna, Niger State, Nigeria

\*Corresponding Author's E-mail: [ebuoceciliaewa@gmail.com](mailto:ebuoceciliaewa@gmail.com) GSM: 08033484598, 08183912984

### ABSTRACT

The study was conducted to assess the growth performance and nutrient digestibility of broiler chickens fed diets containing shea butter cake fermented with *Aspergillus niger* at the starter and finisher phases. One hundred and eighty (180) day-old broiler chicks were assigned to five experimental diets. The control diet (T<sub>1</sub>) contained 0% fermented shea butter cake while T<sub>2</sub>, T<sub>3</sub>, T<sub>4</sub> and T<sub>5</sub> contained 5%, 10%, 15% and 20% fermented shea butter cake respectively. Each treatment had 36 birds with 3 replicates of 12 birds in a completely randomized design. The study lasted for 9 weeks. Results of growth performance at the starter phase revealed statistically similar ( $p > 0.05$ ) values in final weight, total body weight gain, daily weight gain and mortality. However, significant ( $p < 0.05$ ) differences were observed in total feed intake, daily feed intake and feed conversion ratio. The results of growth performance at the finisher phase revealed significant ( $p < 0.05$ ) differences in final weight, total body weight gain, daily weight gain, total feed intake, daily feed intake and feed conversion ratio but no significant ( $p > 0.05$ ) difference in percentage mortality. Nutrient digestibility at the starter phase revealed significant ( $p < 0.05$ ) differences in crude fibre, crude protein, ether extract, ash and nitrogen free extract but no significant ( $P > 0.05$ ) difference in dry matter. At the finisher phase, significant ( $p < 0.05$ ) differences were observed in dry matter, crude protein, ash and nitrogen free extract but no significant ( $p > 0.05$ ) differences in crude fibre and ether extract. Based on the study, it can be concluded that broiler chickens can tolerate up to 20% inclusion of shea butter cake fermented with *Aspergillus niger* in their diets both at the starter and finisher phases without extreme adverse effects on growth performance. However, lower inclusion levels are recommended for optimal digestibility of nutrients.

**KEYWORDS:** Shea butter cake, *Aspergillus niger*, growth performance, nutrient digestibility, broiler chickens

### INTRODUCTION

Agro-industrial by-products (AIBP) are by-products derived in industries after processing main products (usually of plant or animal origin). They are less fibrous, more concentrated and highly nutritious (Aguilera, 1989). AIBP have a huge potential to replace feed ingredients that are competed for by man and animals in the livestock industry. In most developing countries where feed ingredients that supply macro nutrients are becoming scarce or expensive, AIBP have come to the rescue. In subsistence animal husbandry especially in rural areas, these by-products are abundant and form the bulk of feed given to animals. Sindhu *et al.* (2002) listed some benefits of using AIBP as components of livestock feed such as: reduction in production cost, improvement of feed quality and assurance of regular feed supply even during slump period and increase in profit margin. The authors further noted that AIBP contains many toxic compounds (toxins or anti-nutritional factors) which are detrimental to the performance and health of animals. Polygastrics tend

to have the ability to tolerate much higher concentrations of such factors than monogastrics (Sindhu *et al.*, 2002). Usually, the presence of the toxins or anti-nutritional factors (ANFs) affects the availability of nutrients for animals.

One AIBP of plant origin whose utilization has been plagued by the presence of ANFs is shea butter cake. Shea butter cake (SBC) is an agro industrial by-product obtained after fat is extracted from the nuts of shea tree. It is a potential tropical feedstuff which could be useful in livestock feed but the presence of ANFs have hindered its optimum utilization. Annongu *et al.* (1996) and Okai *et al.* (1995) reported that the presence of ANFs in SBC especially tannins have hindered its optimum utilization by poultry. The ANFs are responsible for the bitter taste and unpalatability of the cake to animals. Without processing, the ANFs could prevent the availability of nutrients to animals (Belewu and Yahaya, 2008). Poor and variable growth performances have been observed in poultry when fed shea nut meal based

diets (Atuahene *et al.*, 1998; Olorede and Longe 1999) and this have been attributed to the presence of anti-nutritive factors such as tannins and saponins (Annongu *et al.*, 1996; Okai *et al.*, 1995). The tannin content is almost of the same amount or higher than other tannin-rich feedstuffs like faba beans (*Vicia faba*) and sorghum (*Sorghum vulgare*). Biologically, tannins have adverse effects on feed intake (Armstrong *et al.*, 1974) and nutrient utilization (Smulikowska *et al.*, 2001) in poultry. In order to breakdown the tannins in tannin-rich feed resources, Reddy and Person (1994) have recommended fermentation with certain microorganisms. *Aspergillus niger* is famous fungus used for fermentation of agro-industrial by-products because it can produce enzymes like tannases, lipases, hemicellulases, hydrolases and pectinases (Pinto *et al.*, 2001; Mathivanan *et al.*, 2006) which can act on protein and non-starch polysaccharides. Also, Bhat *et al.* (1998) have reported that *A. niger* possesses tannin-protein complex degrading activity thus making shea butter cake (a tannin-rich feed ingredient) a suitable substrate for it. Therefore the objective of the study is to assess the nutritional value of shea butter cake when fermented with *Aspergillus niger* by evaluating its effect on the growth performances and nutrient digestibilities of broiler chickens at the starter and finisher phases.

## MATERIALS AND METHODS

### Experimental site

The experiment was carried out at the Poultry unit of the Teaching and Research Farm of the Department of Animal Production, Federal University of Technology, Gidan Kwano Campus, Minna, Niger State. Minna is located between latitude 28°N to 37°N and longitude 23°E to 33°E with annual rainfall of 1000 – 1500mm located in the Southern Guinea Savanna Vegetation Zone (Niger State Agricultural Development Project, 2009).

### Processing and Feed formulation

Shea butter cake (SBC) was obtained from a local shea butter processing factory in Bida, Niger State, Nigeria. The shea butter cake was air-dried for 7 days and then pulverized into powdery form. After converting the shea butter cake to powder, it was fermented by mixing the shea butter cake with water in the ratio 1:2 (1kg of shea butter cake: 2 litres of water) after the spores of *Aspergillus niger* (0.25 g/kg) were premixed with the water. The mixture was packed in a plastic covered container, gently firmed, and sealed with adhesive film to provide anaerobic condition before being kept in a container at an ambient temperature of 24°C. The mixture was fermented for 7 days during which it was stirred every day to ensure proper mixing of the *Aspergillus*

*niger* with shea butter cake. The *Aspergillus niger* used in this study was a laboratory strain isolate obtained from the Biochemistry Laboratory of Federal University of Technology Minna, Niger State. After fermentation, the fermented SBC was spread on a polythene sheet in an open place and air-dried at a temperature of 30<sup>o</sup> to 40<sup>o</sup>C for 5 days to attain about 90% dry matter. Five (5) experimental diets were formulated for the broiler starter (Table 1) and finisher (Table 2) phases. In both phases the fermented shea butter cake was included at 0%, 5%, 10%, 15% and 20% for T<sub>1</sub> (control), T<sub>2</sub>, T<sub>3</sub>, T<sub>4</sub> and T<sub>5</sub> respectively.

### Experimental design and Animal management

A total of one hundred and eighty (180) day-old broiler chicks were weighed and randomly allotted to the five treatments with three replicates each in a completely randomized design (CRD). Each replicated pen contained twelve (12) birds, making a total of thirty six (36) birds per treatment. The birds were raised intensively in deep litter system. The pens were constructed to ensure safety and comfort of the birds. The chicks were acclimatized for 3 days during which they were fed commercial starter ration. After the 3 days acclimatization, the chicks were picked randomly and placed in a brooding unit representing a replicate. Throughout the experiment, feed and water were provided *ad libitum*. Feed was given in mash form. All vaccination and medication schedule were strictly adhered to. The experiment lasted for 9 weeks.

### Data collection

Daily feed intake was obtained by subtracting the quantity of the left over feed from the total quantity of the feed supplied to the birds per day. Total feed intake was obtained by summing up the total daily feed intake. Initial body weight was taken at the commencement of the experiment. Thereafter, weighing was done on weekly basis to determine weekly body weight. Weekly body weight gain was obtained by subtracting the body weight of previous week from the body weight of the present week. Total body weight gain was estimated by deducting initial weight from the final weight. Daily weight gain was obtained by dividing the total body weight gain by number of days of the experiment. Feed conversion ratio was calculated by dividing the cumulative values of daily feed intake by daily weight gain. Mortality was properly recorded. Nutrient digestibility determination for the starter phase was done at 4 weeks (6 birds per treatment; 2 per replicate) and the finisher was done at 8<sup>th</sup> week (6 birds per treatment; 2 per replicate). In each of the phases, the birds were first transferred to metabolic cages, weighed and allowed a 3-day acclimatization period. After acclimatization, a three-day nutrient



digestibility trial was conducted during which feed and water were given and left over feed recorded. Also during the three days, the faecal droppings from each replicate were collected, weighed and sun-dried on a daily basis. After the three-day trial, the daily sun-dried faecal samples from each replicate were pooled together on replicate basis and taken to the laboratory for proximate analysis according to the techniques of AOAC (1990) for the determination of nutrient digestibility.

#### Statistical Analysis

Data obtained were subjected to one way Analysis of Variance (ANOVA) for completely randomized design using Statistical Package for Social Sciences (SPSS) version 16. Significantly different means were separated using the Duncan Multiple Range Test.

### RESULTS AND DISCUSSION

The result of growth performance at the starter and finisher phases are displayed in Table 3. At the starter phase, final body weight, total body weight gain, daily weight gain and percentage mortality were not significantly ( $P>0.05$ ) influenced by the treatments but total feed intake, daily feed intake and feed conversion ratio (FCR) were significantly ( $P<0.05$ ) influenced by different inclusion levels of fermented shea butter cake. The values of final body weight, total body weight gain and daily weight gain at the end of the starter phase were highest in T<sub>4</sub> and lowest T<sub>5</sub>. The slight increase in weight values observed in T<sub>4</sub> compared to other treatments could suggest that 15% inclusion of fermented shea butter cake supported muscle deposition and consequently increased growth rate than other inclusion levels at the starter phase. Also, the reduced weight values in T<sub>5</sub> could be attributed to the effects of residual tannins (Annongu *et al.*, 1996) since they consumed diets containing the highest (20%) fermented SBC. Total feed intake and daily feed intake were significantly highest in T<sub>5</sub> and lowest in T<sub>1</sub>. 20% inclusion level could have led to reduced heat increment during feeding thereby resulting in the highest values of feed intake observed in T<sub>5</sub>. T<sub>1</sub> (control) had the best feed conversion ratio implying that absence of fermented shea butter improved the conversion of feed to flesh than other diets at the starter phase. Significant differences for feed intake, feed conversion and mortality are in line with the findings of Dei *et al.* (2008), Atuahene *et al.* (1998) and Annongu *et al.* (1996).

At the finisher phase, significant ( $P<0.05$ ) differences were observed among treatment groups for final body weight, total body weight gain, daily weight gain, total feed intake, daily feed intake, feed conversion

ratio (FCR). However, no difference was observed statistically ( $P>0.05$ ) for mortality rate. The values of final body weight, total body weight gain and daily weight gain at the end of the finisher phase were highest in T<sub>1</sub> and lowest T<sub>5</sub>. The highest weight values observed in T<sub>1</sub> (control) compared to other treatments could suggest that 0% inclusion of fermented shea butter cake supported muscle deposition and consequently growth rate than other inclusion levels at the finisher phase. Also, the reduced weight values in T<sub>5</sub> could confirm the effects of residual tannins observed at the starter phase (Annongu *et al.*, 1996) having consumed diets containing the highest (20%) fermented SBC. High dietary tannins result in reduced weight gains and poor feed efficiencies in birds (Iji *et al.*, 2004). Total feed intake and daily feed intake were significantly highest in T<sub>4</sub> and lowest in T<sub>1</sub>. 15% inclusion level could have led to reduced heat increment during finisher feeding thereby resulting in the highest values of feed intake observed in T<sub>4</sub>. T<sub>1</sub> (control) had the best feed conversion ratio confirming that absence of fermented shea butter cake improved the conversion of feed to flesh than other diets both at the starter and finisher phases. Significant differences for feed intake, weight gain, feed conversion and mortality is in line with the findings of Dei *et al.* (2008), Atuahene *et al.* (1998) and Annongu *et al.* (1996).

Table 4 captures the results of nutrient digestibility for the starter and finisher phases. At the starter phase, significant ( $p<0.05$ ) differences were observed in crude protein, ether extract, crude fibre, ash and nitrogen free extract but dry matter values were statistically similar ( $p>0.05$ ). Nutrient digestibility for dry matter, crude protein, ether extract, crude fibre, ash and nitrogen free extract had very little variations at the starter phase. This suggests that the treatments did not have any adverse effect on the nutrient digestibility at the starter phase.

At the finisher phase significant ( $p<0.05$ ) differences were observed for dry matter, crude protein, ash and nitrogen free extracts but values of crude fibre and ether extract were statistically similar ( $p>0.05$ ). Dry matter values decreased as the inclusion levels of fermented SBC increased. Crude protein and ether extract digestibility were poorest in T<sub>3</sub> – T<sub>5</sub> indicating that increasing levels of fermented SBC decreased the digestion of crude protein and fat in the diets. Digestibilities of ash and nitrogen free extract were poorest in T<sub>5</sub>. The poor digestibility values in T<sub>5</sub> could be attributed to the presence of residual ANFs (tannin, saponin and alkaloids) (Huisman and Tolman, 2001)



## CONCLUSION AND RECOMMENDATIONS

Based on the study, it can be concluded that broiler chickens can tolerate up to 20% inclusion of shea butter cake fermented with *Aspergillus niger* in their diets both at the starter and finisher phases without extreme adverse effects on growth performance. However, lower inclusion levels are recommended for optimal digestibility of nutrients.

## ACKNOWLEDGEMENTS

We are grateful to the Department of Animal Production, Federal University of Technology Minna Gidan Kwano Campus for giving us space at the Teaching and Research Farm to conduct this research.

**Table 1: Ingredient composition of experimental diet at starter phase**

Ingredients (kg)	T <sub>1</sub> (control)	Treatments			
		T <sub>2</sub>	T <sub>3</sub>	T <sub>4</sub>	T <sub>5</sub>
Maize	54.69	51.95	49.22	46.48	43.75
Fermented SBC	0.00	2.73	5.47	8.20	10.94
Groundnut cake	32.31	31.31	31.31	28.31	26.31
Fish meal	3.00	3.00	2.00	3.00	3.00
Rice bran	8.00	8.00	9.00	10.00	13.00
Bone meal	1.00	2.00	2.00	3.00	2.00
Vitamin premix	0.25	0.25	0.25	0.25	0.25
Salt	0.25	0.25	0.25	0.25	0.25
Lysine	0.25	0.25	0.25	0.25	0.25
Methionine	0.25	0.25	0.25	0.25	0.25
<b>Calculated composition</b>					
Crude protein	23.00	23.07	23.07	23.02	23.03
Crude fibre	3.71	3.71	3.86	3.92	4.24
Metabolizable energy (Kcal/kg)	2932.19	2936.80	2956.92	2958.78	2994.97
<b>Analysed composition (%)</b>					
Dry matter	86.80	91.20	90.08	85.60	88.60
Crude protein	22.75	22.75	22.40	23.45	23.63
Crude fibre	12.50	9.00	10.00	8.50	9.00
Ether extract	11.00	11.50	17.00	11.50	14.50
Ash	9.50	7.50	10.00	11.00	12.00
NFE	30.05	40.45	31.40	23.15	29.47

**Premix (vitamin x minerals)** Vitamins; A=7,500 IU, D=500,000 IU, E=100 IU, B1=325 mg, B2=125 mg, B3=500 mg, B6=150 mg, B12=2.5 mg, C=10 mg, K, =15 mg and folic acid= 150 mg. Minerals; Ca=12.5 mg, Cu=8.0 mg, Fe=32 mg, I= 0.8 mg, Se= 100 mg, Mg= 0.25 mg, chlorine= 250 mg, pantothenic acid=14.4 mg, lysine, methionine and terramycine (Broad-spectrum antibiotics and growth promoters).

T<sub>1</sub> (control): 0% fermented shea butter cake inclusion

T<sub>2</sub>: 5% fermented shea butter cake inclusion

T<sub>3</sub>: 10% fermented shea butter cake inclusion

T<sub>4</sub>: 15% fermented shea butter cake inclusion

T<sub>5</sub>: 20% fermented shea butter cake inclusion

SBC: Shea Butter Cake

**Table 2: Ingredient composition of experimental diet at finisher phase**

Ingredients (kg)	T <sub>1</sub> (control)	Treatments			
		T <sub>2</sub>	T <sub>3</sub>	T <sub>4</sub>	T <sub>5</sub>
Maize	67.97	64.57	61.17	57.78	54.38
Fermented SBC	0.00	3.40	6.80	10.20	13.59
Groundnut cake	23.53	23.53	20.53	19.53	17.53
Fish meal	2.00	1.00	1.00	1.00	1.00
Rice bran	2.50	2.50	8.00	6.50	9.00
Bone meal	3.00	4.00	1.50	4.00	3.50
Vitamin premix	0.25	0.25	0.25	0.25	0.25
Salt	0.25	0.25	0.25	0.25	0.25
Lysine	0.25	0.25	0.25	0.25	0.25
Methionine	0.25	0.25	0.25	0.25	0.25
<b>Calculated composition</b>					
Crude protein	19.01	19.01	19.02	19.02	19.09
Crude fibre	3.06	3.10	3.69	3.53	3.80
Metabolizable energy (Kcal/kg)	3032.99	3041.52	3107.00	3097.52	3131.54
<b>Analysed composition (%)</b>					
Dry matter	87.20	85.60	89.60	87.80	87.40
Crude protein	19.60	18.90	19.25	17.78	20.13
Crude fibre	6.50	9.00	8.00	9.00	8.00
Ether extract	15.50	13.50	14.00	12.00	13.50
Ash	8.00	9.50	6.50	10.50	10.50
NFE	37.60	34.70	41.83	36.52	35.27

**Premix (vitamin x minerals)** Vitamins; A=7,500 IU, D=500,000 IU, E=100 IU, B1=325 mg, B2=125 mg, B3=500 mg, B6=150 mg, B12=2.5 mg, C=10 mg, K, =15 mg and folic acid= 150 mg. Minerals: Ca=12.5 mg, Cu=8.0 mg, Fe=32 mg, I= 0.8 mg, Se= 100 mg, Mg= 0.25 mg, chlorine= 250 mg, pantothenic acid=14.4 mg, lysine, methionine and terramycin (Broad-spectrum antibiotics and growth promoters).

T<sub>1</sub> (control): 0% fermented shea butter cake inclusion

T<sub>2</sub>: 5% fermented shea butter cake inclusion

T<sub>3</sub>: 10% fermented shea butter cake inclusion

T<sub>4</sub>: 15% fermented shea butter cake inclusion

T<sub>5</sub>: 20% fermented shea butter cake inclusion

SBC: Shea Butter Cake

**Table 3: Growth performance of broiler chickens fed diets containing varying levels of shea butter cake fermented with *Aspergillus niger* at the starter phase and finisher phases**

Parameters	Treatments					SEM
	T <sub>1</sub> (control)	T <sub>2</sub>	T <sub>3</sub>	T <sub>4</sub>	T <sub>5</sub>	
<b>Starter phase</b>						
Initial body weight(g)	65.58	65.54	65.54	65.52	65.55	0.00
Final body weight(g)	320.27	325.30	322.26	328.11	319.63	1.42
Total body weight gain (g)	254.00	259.33	256.00	262.33	253.67	1.43
Daily weight gain (g)	9.09	9.27	9.17	9.38	9.07	0.05
Total feed intake (g)	538.33 <sup>c</sup>	613.00 <sup>b</sup>	643.33 <sup>ab</sup>	649.67 <sup>a</sup>	670.00 <sup>a</sup>	12.95
Daily feed intake (g)	19.00 <sup>c</sup>	21.33 <sup>b</sup>	22.33 <sup>ab</sup>	23.20 <sup>a</sup>	23.93 <sup>a</sup>	0.42
Feed conversion ratio	2.16 <sup>c</sup>	2.36 <sup>b</sup>	2.51 <sup>ab</sup>	2.48 <sup>ab</sup>	2.64 <sup>a</sup>	0.05
Mortality (%)	0.83	0.00	0.12	0.08	0.08	0.03
<b>Finisher phase</b>						
Initial body weight (g)	320.27	325.30	322.26	328.26	319.63	1.42
Final body weight (g)	1480.00 <sup>a</sup>	1365.00 <sup>ab</sup>	1287.00 <sup>bc</sup>	1247.00 <sup>bc</sup>	1170.70 <sup>c</sup>	31.93
Total body weight gain (g)	1159.00 <sup>a</sup>	1039.30 <sup>ab</sup>	964.00 <sup>bc</sup>	918.33 <sup>bc</sup>	850.67 <sup>c</sup>	31.99
Daily weight gain (g)	33.13 <sup>a</sup>	29.71 <sup>ab</sup>	27.56 <sup>bc</sup>	26.25 <sup>bc</sup>	24.31 <sup>c</sup>	0.91
Total feed intake (g)	2066.70 <sup>c</sup>	2110.00 <sup>bc</sup>	2160.00 <sup>ab</sup>	2223.20 <sup>a</sup>	2150.00 <sup>ab</sup>	1.73
Daily feed intake (g)	59.00 <sup>c</sup>	60.00 <sup>bc</sup>	61.33 <sup>ab</sup>	63.33 <sup>a</sup>	61.00 <sup>bc</sup>	0.46
Feed conversion ratio	1.79 <sup>c</sup>	2.03 <sup>bc</sup>	2.25 <sup>ab</sup>	2.44 <sup>a</sup>	2.54 <sup>a</sup>	0.08
Mortality (%)	0.80	0.12	0.00	0.00	0.78	0.19

Means with different superscripts on the same row differ significantly (P<0.05); SEM: Standard error of mean; T<sub>1</sub> (control): 0% fermented shea butter cake inclusion; T<sub>2</sub>: 5% fermented shea butter cake inclusion; T<sub>3</sub>: 10% fermented shea butter cake inclusion; T<sub>4</sub>: 15% fermented shea butter cake inclusion; T<sub>5</sub>: 20% fermented shea butter cake inclusion

**Table 4: Nutrient digestibility of broiler chickens fed diets containing varying levels of shea butter cake fermented with *Aspergillus niger* at the starter phase and finisher phases**

Parameters (%)	Treatments					SEM
	T <sub>1</sub> (control)	T <sub>2</sub>	T <sub>3</sub>	T <sub>4</sub>	T <sub>5</sub>	
<b>Starter phase</b>						
Dry matter	89.71	90.13	90.70	90.04	89.07	0.27
Crude protein	92.17 <sup>ab</sup>	91.27 <sup>ab</sup>	92.13 <sup>ab</sup>	92.67 <sup>a</sup>	90.70 <sup>b</sup>	0.26
Ether extract	87.23 <sup>b</sup>	87.53 <sup>b</sup>	92.73 <sup>a</sup>	87.93 <sup>b</sup>	88.97 <sup>b</sup>	0.67
Crude fibre	95.20 <sup>a</sup>	88.67 <sup>b</sup>	90.57 <sup>b</sup>	90.23 <sup>b</sup>	88.43 <sup>b</sup>	0.79
Ash	78.67 <sup>ab</sup>	72.07 <sup>b</sup>	80.13 <sup>ab</sup>	83.90 <sup>a</sup>	82.00 <sup>a</sup>	1.51
Nitrogen free extract	91.80 <sup>ab</sup>	93.63 <sup>a</sup>	92.20 <sup>a</sup>	87.63 <sup>b</sup>	90.50 <sup>ab</sup>	0.69
<b>Finisher phase</b>						
Dry matter	68.10 <sup>a</sup>	66.18 <sup>ab</sup>	60.13 <sup>ab</sup>	59.27 <sup>ab</sup>	56.40 <sup>b</sup>	1.61
Crude protein	73.27 <sup>a</sup>	71.97 <sup>a</sup>	62.07 <sup>b</sup>	61.60 <sup>b</sup>	65.83 <sup>ab</sup>	1.70
Ether extract	71.97	71.83	62.37	59.07	58.77	2.23
Crude fibre	60.73	67.93	62.67	64.10	61.07	1.47
Ash	39.37 <sup>ab</sup>	45.57 <sup>a</sup>	50.70 <sup>a</sup>	38.47 <sup>ab</sup>	26.73 <sup>b</sup>	2.71
Nitrogen free extract	73.40 <sup>a</sup>	66.90 <sup>ab</sup>	70.90 <sup>ab</sup>	66.67 <sup>ab</sup>	62.36 <sup>b</sup>	1.58

Means with different superscripts on the same row differ significantly (P<0.05); SEM: Standard error of mean; T<sub>1</sub> (control): 0% fermented shea butter cake inclusion; T<sub>2</sub>: 5% fermented shea butter cake inclusion; T<sub>3</sub>: 10% fermented shea butter cake inclusion; T<sub>4</sub>: 15% fermented shea butter cake inclusion; T<sub>5</sub>: 20% fermented shea butter cake inclusion



## REFERENCES

- A.O.A.C. (1990). Association of Analytical Chemists: Official methods of analyses 18th Edition, Washington, D.C, pp. 12 - 19.
- Aguilera, J. F. (1989). Use of Agro-industrial by-products in the feeding of ruminants. *Revista Argentina de Produccion Animal*, 9: 253–67.
- Annongu, A. A., Termeulen, U., Atteh, J. O. and Apata, D. F. (1996). Toxicological assessment of native and industrial fermented shea butter cake in nutrition of broilers. *Archiv für Geflügelkunde*, 60: 221–226.
- Armstrong, W. D., Featherston, W. R. and Rogler, J. C. (1974). Effects of bird resistant sorghum grain and various commercial tannins on chick performance. *Poultry Science*. 53: 2137–2142.
- Atuahene, C. C., Donkoh, A. and Asante, F. (1998). Value of sheanut cake as a dietary ingredient for broiler chickens. *Animal Feed Science Technology*, 72: 133–142.
- Belewu, M. A., and Yahaya, A. A. (2008). Effects of *Aspergillus niger* treated Shea butter cake based diets on nutrient intake and weight gain of Red Sokoto goat. *African Journal of Biotechnology*, 7 (9): 1357-1361.
- Bhat, T. K., Singh, B. and Sharma, O. P. (1998). Microbial degradation of tannins - A current perspective. *Biodegradation*, 9: 343–357.
- Dei, H. K., Rose, S. P., Mackenzie, A. M. and Amarowicz, R. (2008). Growth performance of broiler chickens fed diets containing shea nut (*Vitellaria paradoxa*, Gaertn.) meal fermented with *Aspergillus niger*. *Poultry Science*, 87: 1773–1778.
- Huisman, J. and Tolman, G. H. (2001). Anti-nutritional factors in the plant proteins of diets for non ruminants. Recent developments in pig nutrition, 3: 261–291. Netherlands.
- Iji, P. A., Khumalo, K., Slippers, S. and Gous, R. M. (2004). Intestinal function and body growth of broiler chickens on maize-based diets supplemented with mimosa tannins and microbial enzyme. *Journal of the Science of Food and Agriculture*, 84: 1451–1458.
- Mathivanan, R., Selvaraj, P. and Nanjappan, K. (2006). Feeding of fermented soybean meal on broiler performance. *International Journal of Poultry Science*, 5: 868–872.
- Niger State Agricultural Development Project. (2009). Quarterly Farmers' magazine, 27 series.
- Okai, D. B., Topps, J. H., English, P., Tuah, A. K. and Osafo, E. L. K. (1995). The effects of processed sheanut cake and groundnut skins on the growth performance and organ characteristics of rats. *Ghana Journal of Biochemistry, Biotechnology and Molecular Biology*, 3: 76–82.
- Oloredo, B. R. and Longe, O. C. (1999). Growth performance of pullet chicks fed graded levels of shea butter Cake. *Sokoto Journal of Veterinary Sciences*, 1(1): 8 – 15.
- Pinto, G. A. S., Leite, S. G. F., Terzi, S. C. and Couri. C. (2001). Selection of tannase-producing *Aspergillus niger* strains. *Brazilian Journal of Microbiology*, 32: 24–26.
- Reddy, N. R., and Pierson, M. D. (1994). Reduction in anti-nutritional and toxic components in plant foods by fermentation. *Food Research International*, 27: 281–290.
- Sindhu, A. A., Khan, M. A., Mahr-Un-Nisa and Sarwar, M. (2002). Agro-Industrial by-products as a potential source of livestock feed. *International Journal of Agriculture and Biology*, 4(2): 307 – 310.
- Smulikowska, S., Pastuszewska, B., Swiech, E., Ochtabinska, A., Mieczkowska, A., Nguyen, V. C. and Buraczewska, K. (2001). Tannin content affects negatively nutritive value of pea for monogastrics. *Journal of Animal and Feed Sciences*, 10: 511–523.

# CARCASS CHARACTERISTICS, CARCASS COMPOSITION AND MEAT QUALITY OF BROILER CHICKENS FED DIETS CONTAINING SHEA BUTTER CAKE FERMENTED WITH *Aspergillus niger*

Jiya<sup>1</sup>, E. Z., E. C. Ewa<sup>2\*</sup>, M. B. Tihamiyu<sup>3</sup>

<sup>1,2,3</sup> Department of Animal Production, School of Agriculture and Agricultural Technology, Federal University of Technology, P. M. B. 65 Minna, Niger State, Nigeria

\*Corresponding Author's E-mail: [ebuoceciliaewa@gmail.com](mailto:ebuoceciliaewa@gmail.com) GSM: 08033484598, 08183912984

## ABSTRACT

The study was conducted to evaluate carcass/internal organs characteristics, carcass composition and meat quality characteristics of broiler chickens fed diets containing shea butter cake fermented with *Aspergillus niger*. One hundred and eighty day-old chicks were used for the experiment. Five experimental diets were formulated for the starter and finisher phases. The control diet (T<sub>1</sub>) contained 0% fermented shea butter cake while T<sub>2</sub>, T<sub>3</sub>, T<sub>4</sub> and T<sub>5</sub> contained 5%, 10%, 15% and 20% fermented shea butter cake respectively. Each dietary treatment was assigned to a group 36 birds having 3 replicates of 12 birds in a completely randomized design. The experiment lasted for 9 weeks. Results of carcass and internal organs characteristics revealed no significant ( $p > 0.05$ ) differences in live weight, slaughter weight, dressed weight and weights of head, neck, breast, thigh, back, drumsticks, shanks, wings, liver, lungs, gizzard, intestines and abdominal fat. However, there were significant ( $p < 0.05$ ) differences in dressing percentage and heart weight. Results of carcass composition revealed significant ( $p < 0.05$ ) differences in moisture content, ether extract and ash. There was no significant ( $p > 0.05$ ) difference in crude protein. Results of meat quality characteristics revealed significant ( $p < 0.05$ ) differences in water holding capacity, cooking yield and cooking loss but no significant ( $p > 0.05$ ) difference in pH. Based on the findings from the study, it can be concluded that up to 20% inclusion of shea butter cake fermented with *Aspergillus niger* had no adverse effects on carcass and internal organs characteristics since nearly all parameters measured were statistically insignificant. However, 15% level of inclusion resulted in the best meat quality characteristics.

**KEYWORDS:** Shea butter cake, *Aspergillus niger*, carcass characteristics, carcass composition, meat quality

## INTRODUCTION

Shea butter tree, *Vitellaria paradoxa* produces shea fruits from which the nut is obtained. Shea butter cake (SBC) is an agro industrial by-product obtained after the fat is extracted from the nut. The shea butter tree grows wild in the savanna zones of Africa. In Nigeria, the tree abundantly grows in the wild especially in the middle-belt region like the Federal Capital Territory (FCT - Abuja), Benue, Kwara and Niger States (Badifu, 1993). As an agro-industrial by-product, shea butter cake is a potential tropical feed resource but its optimum utilization by livestock (especially at high levels) has been hampered the presence of anti-nutritional factors (ANFs). Also, the presence of ANFs makes the cake bitter in taste and therefore unpalatable to livestock (Belewu and Yahaya, 2008). Atuahene *et al.* (1998) and Olorede and Longe (1999) examined growth responses of poultry to shea nut meal based diets and reported poor and variable growth performances which were attributed to the presence of anti-nutritive factors such as tannins and saponins (Annongu *et al.*, 1996; Okai *et al.*, 1995). Therefore improving its nutritive value will make it a valuable alternative feed ingredient for livestock. The tannin content is comparable to or higher than other tannin-rich

feedstuffs like faba beans (*Vicia faba*) and sorghum (*Sorghum vulgare*). The biological significance of tannins in poultry nutrition is associated with their characteristic adverse effects on feed intake (Armstrong *et al.*, 1974) and nutrient utilization (Smulikowska *et al.*, 2001). Therefore, to improve the nutritive value of tannin-rich feedstuffs, fermentation (wet incubation of a feedstuff) is recommended (Reddy and Pierson, 1994). The fermentation process can create suitable conditions that favour the growth of microorganisms such as *Aspergillus*, *Bacillus*, *Candida*, *Corynebacterium*, *Fusarium*, *Klebsiella* and *Penicillium* which break down tannins (Reddy and Pierson, 1994). It has been suggested that during incubation, tannins may react to form higher oligomeric polymers that are not readily soluble in water and therefore, are less likely to interfere with digestive enzymes or other proteins (Reichert *et al.*, 1980). Fermentation has great potential for recycling some agro-industrial by-products into useful alternative animal feed ingredients in developing countries. The process is chemical-free and can be easily managed in on-farm conditions or on an industrial scale (Dei *et al.*, 2008).



Certain microbes have been extensively used for fermentation of feedstuffs and notable amongst them is *Aspergillus niger*. *Aspergillus niger* is a fungus that can produce enzymes like hemicellulases, hydrolases, pectinases, lipases, and tannases (Pinto *et al.*, 2001; Mathivanan *et al.*, 2006). As a result, it has been used widely for improving agro by-products through its action on substrates such as protein and non-starch polysaccharides. Fermentation processes using aspergilli have been used to improve the nutritive value of some feedstuffs such as soybeans (Chah *et al.*, 1975; Mathivanan *et al.*, 2006), guar meal (Nagra *et al.*, 1998), and koji feed (Yamamoto *et al.*, 2007) for poultry. The desirable characteristics of the fermented products include their acceptability by birds (Nagra *et al.*, 1998) and nutrient availability (Hong *et al.*, 2004). Furthermore, *Aspergillus niger* has been reported to possess tannin–protein complex degrading activity (Bhat *et al.*, 1998) which makes shea butter cake a suitable substrate for it. This study therefore seeks to assess the nutritional value of shea butter cake when fermented with *Aspergillus niger*. The assessment will be carried out by evaluating carcass/internal organs characteristics, carcass composition and meat quality parameters in broiler chickens when fed diets containing shea butter cake fermented *Aspergillus niger*.

## MATERIALS AND METHODS

### Location of the study

The experiment was conducted at the Poultry unit of the Teaching and Research Farm of the Department of Animal Production, Federal University of Technology, Gidan Kwano Campus, Minna, Niger State. Minna is located between latitude 28°N to 37°N and longitude 23°E to 33°E with annual rainfall of 1000 – 1500mm located in the Southern Guinea Savanna Vegetation Zone (Niger State Agricultural Development Project, 2009).

### Processing and Feed Formulation

Shea butter cake (SBC) was obtained from a local shea butter processing factory in Bida, Niger State, Nigeria. The shea butter cake was air-dried for 7 days and then pulverized into powdery form. After converting the shea butter cake to powder, it was fermented by mixing the shea butter cake with water in the ratio 1:2 (1kg of shea butter cake:2 litres of water) after the spores of *Aspergillus niger* (0.25 g/kg) were premixed with the water. The mixture was packed in a plastic covered container, gently firmed, and sealed with adhesive film to provide anaerobic condition before being kept in a container at an ambient temperature of 24°C. The mixture was fermented for 7 days during which it was stirred every day to ensure proper mixing of the *Aspergillus niger* with shea butter cake. The *Aspergillus niger*

used in this study was a laboratory strain isolate obtained from the Biochemistry Laboratory of Federal University of Technology Minna, Niger State. After fermentation, the fermented SBC was spread on a polythene sheet and air-dried at temperature of 30<sup>0</sup> to 40<sup>0</sup>C for 5 days to attain about 90% dry matter. Five (5) experimental diets were formulated for the broiler starter (Table 1) and finisher (Table 2) phases. In both phases the fermented SBC was included at 0%, 5%, 10%, 15% and 20% for T<sub>1</sub> (control), T<sub>2</sub>, T<sub>3</sub>, T<sub>4</sub> and T<sub>5</sub> respectively.

### Experimental design and Animal Management

One hundred and eighty (180) day-old broiler chicks were purchased and used for the experiment. At the starter phase, the chicks were weighed and allotted to the five experimental treatments in a completely randomized design (CRD). Each treatment had 36 chicks with three replicates of 12 chicks. The replicates were housed in fifteen (15) floor pens which were properly constructed and disinfected before the arrival of the chicks. The birds were acclimatized for three days after which the experimental diets were given to them in mash form. Throughout the experiment, feed and water was provided *ad libitum*. Vaccination and medication schedule were strictly adhered to throughout the experiment.

### Data collection

At the end of nine weeks, six birds from each treatment (2 per replicate) were randomly picked and fasted for 12 hours in preparation for slaughter. Prior to slaughter, live weights were obtained. The birds were then slaughtered by severing the jugular vein after which they were bled and slaughtered weight was obtained. They were further dipped in hot water for one minute and de-feathered. The heads, shanks, wings and viscera were removed for the determination of dressed weights and dressing percentages. The weights of the eviscerated parts (heart, liver, lungs, gizzard, intestines and abdominal fat) and the cut-up-parts (head, neck, breast, thigh, wings, drumstick and back) were also obtained. The weights of the cut-up parts were expressed as percentages of dressed weight but internal organs were expressed as percentage of live weight. After carcass evaluation, the breast muscles were deboned and samples were obtained, processed and subjected to proximate analysis according to the techniques of AOAC (1990) for the determination of the moisture content, crude protein, ether extract and ash. pH of the broiler chicken meat was determined using a pH meter. Water holding capacity (WHC), cooking yield (CY) and cooking loss (CL) of broiler chicken meat were determined with the following formulas:

$$\text{WHC} = \text{IMW} - \text{PMW}/\text{IMW} \times 100$$



$$CY = \frac{WRM - WCM}{WRM} \times 100$$

$$CL = \frac{PFMW - CY}{PFMW} \times 100$$

Where:

IMW = Initial meat weight

PMW = Pressed meat weight

WRM = Weight of raw meat

WCM = Weight of cooked meat

PFMW = Pre-freezing meat weight

### Statistical Analysis

The data collected from this study were subjected to one way analysis of variance (ANOVA) for completely randomized design using Statistical Package for Social Sciences (SPSS) version 16. The variations in means were separated using the Duncan Multiple Range Test.

## RESULTS AND DISCUSSION

Table 3 shows the result of the carcass and internal organ characteristics. The result showed that there were no significant ( $P > 0.05$ ) differences in live weight, slaughter weight, dressed weight and weights of head, neck, breast, thigh, back, drumsticks, shanks, wings, liver, lungs, gizzard, intestines and abdominal fat across the treatments. However, there were significant ( $p < 0.05$ ) differences in dressing percentage and heart weight. The highest value of dressing percentage in  $T_1$  (control) could imply that absence (0%) of fermented SBC in their diet resulted in faster growth rate and consequently increased dressing percentage in comparison with other treatments. Significantly highest value of dressing percentage for the control diet in this study is in line with the findings of Atuahene *et al.*, (1998) when shea nut cake was included in broiler diets at 0, 2.5, 5, and 7 percent. The lower values for live weight, slaughter weight, dressed weight and dressing percentages among treated birds in comparison with the control could suggest that fermented SBC inclusion depressed growth rate/weight gain and consequently carcass yield. Atuahene *et al.* (1998) reported that inclusion of shea nut cake above 2.5% (5% and 7.5%) significantly depressed weight gain which led to a significant depression in dressing percentage. Also, Dei *et al.* (2008) reported significant decrease in weight gain which consequently led to a significant decrease in live weight when fermented and unfermented shea nut meal were included in broiler diets. The lowest heart weight observed for the control ( $T_1$ ) could imply that absence of shea butter inclusion led to a decrease in the size and weight of the heart. Absence of significant differences ( $p > 0.05$ ) in weights of gizzard and intestine agrees with the works of Aguihe *et al.* (2017) when shea butter cake based diets were supplemented with probiotics for broiler chickens.

The result of carcass composition is shown in Table 4. The result showed significant ( $p < 0.05$ ) differences in moisture content, ether extract and ash but no significant ( $p > 0.05$ ) difference in crude protein. The moisture content values of broiler meat for treatment diets were higher than the control except  $T_3$  which was 0.12% lower than the control. The significantly highest value observed in  $T_2$  may suggest that 5% inclusion of fermented SBC caused a higher retention of moisture in broiler meat on dry matter basis. The values for crude protein were the same for  $T_1$  to  $T_4$  but  $T_5$  was 0.23% lower than others. This implies that 0% inclusion and up to 15% fermented SBC inclusion led to an isonitrogenous outcome for crude protein values of the broiler meat. The highest and lowest values of ether extract in  $T_2$  and  $T_5$  respectively, implies that 5% fermented SBC inclusion slightly elevated the fat content of broiler meat and 20% inclusion slightly decreased the fat content of broiler meat. Ash content values indicate that 0%, 10% and 20% of fermented SBC inclusion caused a higher retention of minerals in the broiler meat than 5% and 15% levels. On a general note, significant differences observed among treatments may have been caused by variations in proximate composition of feeds. It has been stated that nutrition significantly influences the proximate composition of broiler meat. Nutritional factors that affect chemical composition and quality of broiler meat are: Choice of feed ingredients for feed formulation, chemical composition of feed ingredients and energy and protein values of formulated rations (Snežana *et al.*, 2010).

Table 5 reveals the result of meat quality characteristics. Significant ( $p < 0.05$ ) differences were observed for all parameters measured except pH. All the pH values were very close to neutrality. The highest value for water holding capacity observed in  $T_4$  could imply that 15% of fermented SBC increased the ability of meat muscles to retain water intracellularly when compared with other treatments. The next value comparable with  $T_4$  was  $T_1$  suggesting that absence of fermented shea butter inclusion also supports the water holding capacity of broiler meat. The highest value for cooking yield observed in  $T_4$  could be attributed to its high water holding capacity in comparison with other treatments which was also sustained after cooking. Cooking loss value in  $T_4$  was the least as a result of good water holding capacity and good cooking yield. The results of cooking yield and cooking loss revealed a confirmatory order. Ranking the values in terms of the best cooking yield we have  $T_4$ ,  $T_2$ ,  $T_1$ ,  $T_5$  and  $T_3$ . The same treatment order was also observed for cooking loss.

## **CONCLUSION AND RECOMMENDATIONS**

Based on the findings from the study, it can be concluded that up to 20% inclusion of shea butter cake fermented with *Aspergillus niger* had no adverse effect on carcass and internal organ characteristics of broiler chickens since nearly all parameters measured (except dressing percentage and heart weight) were statistically similar. On the other hand, most of the parameters measured for carcass composition and meat quality characteristics were significantly influenced except crude protein and pH. It is therefore recommended that for optimum carcass yield, up to 20% level of shea butter cake fermented with *Aspergillus niger* could be included in broiler chicken diet whereas for best meat quality characteristics, 15% level of inclusion is recommended.

## **ACKNOWLEDGEMENTS**

We are grateful to the Department of Animal Production, Federal University of Technology Minna Gidan Kwano Campus for giving us space in the Teaching and Research Farm to conduct this research.



**Table 1: Ingredient composition of experimental diet at starter phase**

Ingredients (kg)	T <sub>1</sub> (control)	Treatments			
		T <sub>2</sub>	T <sub>3</sub>	T <sub>4</sub>	T <sub>5</sub>
Maize	54.69	51.95	49.22	46.48	43.75
Fermented SBC	0.00	2.73	5.47	8.20	10.94
Groundnut cake	32.31	31.31	31.31	28.31	26.31
Fish meal	3.00	3.00	2.00	3.00	3.00
Rice bran	8.00	8.00	9.00	10.00	13.00
Bone meal	1.00	2.00	2.00	3.00	2.00
Vitamin premix	0.25	0.25	0.25	0.25	0.25
Salt	0.25	0.25	0.25	0.25	0.25
Lysine	0.25	0.25	0.25	0.25	0.25
Methionine	0.25	0.25	0.25	0.25	0.25
<b>Calculated composition</b>					
Crude protein	23.00	23.07	23.07	23.02	23.03
Crude fibre	3.71	3.71	3.86	3.92	4.24
Metabolizable energy (Kcal/kg)	2932.19	2936.80	2956.92	2958.78	2994.97
<b>Analysed composition (%)</b>					
Dry matter	86.80	91.20	90.08	85.60	88.60
Crude protein	22.75	22.75	22.40	23.45	23.63
Crude fibre	12.50	9.00	10.00	8.50	9.00
Ether extract	11.00	11.50	17.00	11.50	14.50
Ash	9.50	7.50	10.00	11.00	12.00
NFE	30.05	40.45	31.40	23.15	29.47

**Premix (vitamin x minerals)** Vitamins; A=7,500 IU, D=500,000 IU, E=100 IU, B1=325 mg, B2=125 mg, B3=500 mg, B6=150 mg, B12=2.5 mg, C=10 mg, K, =15 mg and folic acid= 150 mg. Minerals: Ca=12.5 mg, Cu=8.0 mg, Fe=32 mg, I= 0.8 mg, Se= 100 mg, Mg= 0.25 mg, chlorine= 250 mg, pantothenic acid=14.4 mg, lysine, methionine and terramycine (Broad-spectrum antibiotics and growth promoters).

T<sub>1</sub> (control): 0% fermented shea butter cake inclusion ,

T<sub>2</sub>: 5% fermented shea butter cake inclusion

T<sub>3</sub>: 10% fermented shea butter cake inclusion

T<sub>4</sub>: 15% fermented shea butter cake inclusion

T<sub>5</sub>: 20% fermented shea butter cake inclusion

SBC: Shea Butter Cake



**Table 2: Ingredient composition of experimental diet at finisher phase**

Ingredients (kg)	T <sub>1</sub> (control)	Treatments			
		T <sub>2</sub>	T <sub>3</sub>	T <sub>4</sub>	T <sub>5</sub>
Maize	67.97	64.57	61.17	57.78	54.38
Fermented SBC	0.00	3.40	6.80	10.20	13.59
Groundnut cake	23.53	23.53	20.53	19.53	17.53
Fish meal	2.00	1.00	1.00	1.00	1.00
Rice bran	2.50	2.50	8.00	6.50	9.00
Bone meal	3.00	4.00	1.50	4.00	3.50
Vitamin premix	0.25	0.25	0.25	0.25	0.25
Salt	0.25	0.25	0.25	0.25	0.25
Lysine	0.25	0.25	0.25	0.25	0.25
Methionine	0.25	0.25	0.25	0.25	0.25
<b>Calculated composition</b>					
Crude protein	19.01	19.01	19.02	19.02	19.09
Crude fibre	3.06	3.10	3.69	3.53	3.80
Metabolizable energy (Kcal/kg)	3032.99	3041.52	3107.00	3097.52	3131.54
<b>Analysed composition (%)</b>					
Dry matter	87.20	85.60	89.60	87.80	87.40
Crude protein	19.60	18.90	19.25	17.78	20.13
Crude fibre	6.50	9.00	8.00	9.00	8.00
Ether extract	15.50	13.50	14.00	12.00	13.50
Ash	8.00	9.50	6.50	10.50	10.50
NFE	37.60	34.70	41.83	36.52	35.27

**Premix (vitamin x minerals)** Vitamins; A=7,500 IU, D=500,000 IU, E=100 IU, B1=325 mg, B2=125 mg, B3=500 mg, B6=150 mg, B12=2.5 mg, C=10 mg, K, =15 mg and folic acid= 150 mg. Minerals: Ca=12.5 mg, Cu=8.0 mg, Fe=32 mg, I= 0.8 mg, Se= 100 mg, Mg= 0.25 mg, chlorine= 250 mg, pantothenic acid=14.4 mg, lysine, methionine and terramycin (Broad-spectrum antibiotics and growth promoters).

T<sub>1</sub> (control): 0% fermented shea butter cake inclusion

T<sub>2</sub>: 5% fermented shea butter cake inclusion

T<sub>3</sub>: 10% fermented shea butter cake inclusion

T<sub>4</sub>: 15% fermented shea butter cake inclusion

T<sub>5</sub>: 20% fermented shea butter cake inclusion

SBC: Shea Butter Cake

**Table 3: Carcass and internal organ characteristics of broiler chickens fed diets containing varying levels of shea butter cake fermented with *Aspergillus niger***

Parameters	Treatments					SEM
	T <sub>1</sub>	T <sub>2</sub>	T <sub>3</sub>	T <sub>4</sub>	T <sub>5</sub>	
Live weight (g)	1750.00	1500.00	1700.00	1550.00	1550.00	45.83
Slaughter weight (g)	1680.00	1415.00	1550.00	1465.00	1465.00	51.02
Dressed weight (g)	1350.00	1100.00	1250.00	1150.00	1150.00	39.44
Dressing percentage (%)	77.13 <sup>a</sup>	73.33 <sup>b</sup>	73.50 <sup>b</sup>	74.16 <sup>b</sup>	74.17 <sup>b</sup>	0.51
Head (%)	1.86	1.77	1.89	1.80	2.09	0.19
Neck (%)	3.95	3.64	3.26	3.11	3.94	0.25
Back (%)	8.40	7.36	8.12	6.96	7.20	0.53
Breast (%)	10.51	9.68	10.07	10.38	11.86	0.70
Thigh (%)	8.55	8.73	8.25	8.50	7.98	0.66
Drum stick (%)	6.26	7.18	6.86	6.87	6.33	0.58
Shank (%)	2.50	3.50	3.04	3.34	2.55	0.26
Wings (%)	8.56	7.14	6.14	7.76	7.46	0.47
Heart (%)	0.18 <sup>c</sup>	0.29 <sup>a</sup>	0.24 <sup>c</sup>	0.19 <sup>c</sup>	0.26 <sup>b</sup>	0.02
Liver (%)	1.00	0.67	0.73	0.61	0.65	0.06
Lungs (%)	0.46	0.47	0.23	0.26	0.29	0.04
Gizzard (%)	1.13	1.47	0.84	0.94	1.17	0.12
Intestines (%)	3.13	3.00	3.18	3.19	2.82	0.20
Abdominal fat (%)	0.75	0.84	0.56	0.78	0.82	0.09

Means on the same row with different superscripts are significantly ( $p < 0.05$ ) different; SEM: Standard Error of Mean; T<sub>1</sub> (control): 0% fermented shea butter cake inclusion; T<sub>2</sub>: 5% fermented shea butter cake inclusion; T<sub>3</sub>: 10% fermented shea butter cake inclusion; T<sub>4</sub>: 15% fermented shea butter cake inclusion; T<sub>5</sub>: 20% fermented shea butter cake inclusion

**Table 4: Carcass composition of broiler chicken meat fed diets containing varying levels of shea butter cake fermented with *Aspergillus niger***

Parameters (%)	Treatments					SEM
	T <sub>1</sub>	T <sub>2</sub>	T <sub>3</sub>	T <sub>4</sub>	T <sub>5</sub>	
Moisture content	65.75 <sup>d</sup>	75.47 <sup>a</sup>	65.63 <sup>d</sup>	70.10 <sup>b</sup>	68.97 <sup>c</sup>	1.20
Crude protein	18.75	18.75	18.75	18.75	18.52	0.04
Ether extract	1.24 <sup>b</sup>	2.00 <sup>a</sup>	1.36 <sup>b</sup>	1.84 <sup>a</sup>	1.00 <sup>b</sup>	0.13
Ash content	4.55 <sup>b</sup>	3.44 <sup>d</sup>	4.76 <sup>a</sup>	3.85 <sup>c</sup>	4.35 <sup>b</sup>	0.16

Means on the same row with different superscripts are significantly ( $p < 0.05$ ) different; SEM: Standard Error of Mean; T<sub>1</sub> (control): 0% fermented shea butter cake inclusion; T<sub>2</sub>: 5% fermented shea butter cake inclusion; T<sub>3</sub>: 10% fermented shea butter cake inclusion; T<sub>4</sub>: 15% fermented shea butter cake inclusion; T<sub>5</sub>: 20% fermented shea butter cake inclusion

**Table 5: Meat quality characteristics of broiler chickens fed diets containing varying levels of shea butter cake fermented with *Aspergillus niger***

Parameters	Treatments					SEM
	T <sub>1</sub>	T <sub>2</sub>	T <sub>3</sub>	T <sub>4</sub>	T <sub>5</sub>	
pH	6.45	6.43	6.44	6.53	6.50	0.04
WHC (%)	51.59 <sup>b</sup>	34.93 <sup>d</sup>	34.17 <sup>e</sup>	52.37 <sup>a</sup>	39.92 <sup>c</sup>	5.65
Cooking yield (%)	83.35 <sup>c</sup>	84.34 <sup>b</sup>	78.37 <sup>e</sup>	89.33 <sup>a</sup>	81.36 <sup>d</sup>	1.21
Cooking loss (%)	16.85 <sup>c</sup>	15.91 <sup>d</sup>	21.86 <sup>a</sup>	10.94 <sup>e</sup>	18.88 <sup>b</sup>	1.20

Means on the same row with different superscripts are significantly ( $p < 0.05$ ) different; SEM: Standard Error of Mean; T<sub>1</sub> (control): 0% fermented shea butter cake inclusion; T<sub>2</sub>: 5% fermented shea butter cake inclusion; T<sub>3</sub>: 10% fermented shea butter cake inclusion; T<sub>4</sub>: 15% fermented shea butter cake inclusion; T<sub>5</sub>: 20% fermented shea butter cake inclusion

## REFERENCES

- A.O.A.C. (1990). Association of Analytical Chemists: Official methods of analyses 18<sup>th</sup> Edition, Washington, D.C, pp. 12 – 19.
- Aguihe, P. C., Kehinde, A. S., Abdulmumini, S., Ospina-Rojas, I. C. and Murakami, A. E. (2017). Effect of dietary probiotic supplementation on carcass traits and haematological responses of broiler chickens fed shea butter cake based diets. *Acta Scientiarum. Animal Sciences*, 39(3): 265-271.
- Annongu, A. A., Termeulen, U., Atteh, J. O. and Apata, D. F. (1996). Toxicological assessment of native and industrial fermented shea butter cake in nutrition of broilers. *Archiv für Geflügelkunde*, 60: 221–226.
- Armstrong, W. D., Featherston, W. R. and Rogler, J. C. (1974). Effects of bird resistant sorghum grain and various commercial tannins on chick performance. *Poultry Science*, 53: 2137–2142.
- Atuahene, C. C., Donkoh, A. and Asante, F. (1998). Value of sheanut cake as a dietary ingredient for broiler chickens. *Animal Feed Science Technology*, 72: 133–142.
- Badifu, G. I. O. (1993). Food potentials of some unconventional oil seeds grown in Nigeria, A brief review. *Pant Foods for human nutrition* 43: 211- 224. Kluwer Academic Publishers printed in the Netherlands.
- Belewu, M. A., and Yahaya, A. A. (2008). Effects of *Aspergillus niger* treated shea butter cake based diets on nutrient intake and weight gain of Red Sokoto goat. *African Journal of Biotechnology*, 7(9): 1357-1361.
- Bhat, T. K., Singh, B. and Sharma, O. P. (1998). Microbial degradation of tannins - A current perspective. *Biodegradation*, 9: 343–357.
- Chah, C. C., Carlson, C. W., Semeniuk, G., Palmer, I. S. and Hesseltine, C. W. (1975). Growth promoting effects of fermented soybeans for broilers. *Poultry Science*, 54: 600–609.
- Dei, H. K., Rose, S. P., Mackenzie, A. M. and Amarowicz, R. (2008). Growth performance of broiler chickens fed diets containing shea nut (*Vitellaria paradoxa*, Gaertn.) meal fermented with *Aspergillus niger*. *Poultry Science*, 87: 1773–1778.
- Hong, K. L., Lee, C. H. and Kim, S. W. (2004). *Aspergillus oryzae* GB-107 fermentation improves nutritional quality of food soybeans and feed soybean meals. *Journal of Medicinal Food*, 7: 430–435.
- Mathivanan, R., Selvaraj, P. and Nanjappan, K. (2006). Feeding of fermented soybean meal on broiler performance. *International Journal of Poultry Science*, 5: 868–872.
- Nagra, S. S., Sethi, R. P. and Chopra, A. K. (1998). Feeding of fermented guar (*Cyamopsis tetragonoloba* L. taub) meal to broiler chicks. *Indian Journal of Animal Production and Management*, 14: 40–44.
- Niger State Agricultural Development Project. (2009). Quarterly Farmers' magazine, 27 series.
- Okai, D. B., Topps, J. H., English, P., Tuah, A. K. and Osafo, E. L. K. (1995). The effects of processed sheanut cake and groundnut skins on the growth performance and organ characteristics of rats. *Ghana Journal of Biochemistry, Biotechnology and Molecular Biology*, 3: 76–82.
- Oloredo, B. R. and Longe, O. C. (1999). Growth performance of pullet chicks fed graded levels of shea butter Cake. *Sokoto Journal of Veterinary Sciences*, 1(1): 1 – 15.
- Pinto, G. A. S., Leite, S. G. F., Terzi, S. C. and Couri, C. (2001). Selection of tannase-producing *Aspergillus niger* strains. *Brazilian Journal of Microbiology*, 32: 24–26.
- Reddy, N. R., and Pierson, M. D. (1994). Reduction in anti-nutritional and toxic components in plant foods by fermentation. *Food Research International*, 27: 281–290.
- Reichert, R. D., Fleming, E. S. and Schwab, D. J. (1980). Tannin deactivation and nutritional improvement of sorghum by anaerobic storage of H<sub>2</sub>O, HCl, NaOH-treated grain. *Journal of Agricultural and Food Chemistry*, 28: 824–829.
- Smulikowska, S., Pastuszewska, B., Swiech, E., Ochtabinska, A., Mieczkowska, A., Nguyen, V. C. and Buraczewska, K. (2001). Tannin content affects negatively nutritive value of pea for monogastrics. *Journal of Animal and Feed Sciences*, 10: 511–523.
- Snežana, B. B., Zlatica, P., Milun, D. P., Vladimir, D., Simeon, R. (2010). Broiler meat quality: Proteins and lipids of muscle tissue. *African Journal of Biotechnology*, 9(54): 9177-9182.
- Yamamoto, M., Saleh, F., Tahir, M., Ohtsuka, A. and Hayashi, K. (2007). The effect of Koji-feed (fermented distillery by-product) on the growth performance and nutrient metabolizability in broiler. *Japanese Poultry Science*, 44: 291–296.



# EFFECT OF RURAL YOUTHS MIGRATION ON MAIZE PRODUCTION IN KONTAGORA LOCAL GOVERNMENT AREA OF NIGER STATE, NIGERIA

Abdullahi<sup>1</sup>, A., Baba<sup>2</sup>, K.M. and Salihu<sup>1</sup>, I. T.

<sup>1</sup>Department of Agricultural Extension and Rural Development  
Federal University of Technology, Minna, P.M.B. 65, Niger State, Nigeria

<sup>2</sup>Department of Agricultural Economics and Farm Management  
Federal University of Technology, Minna, P.M.B. 65, Niger State, Nigeria

\*Corresponding Author's E-mail: [abdulwahababdullahi6@gmail.com](mailto:abdulwahababdullahi6@gmail.com), GSM: 07061848379

## ABSTRACT

*The study assessed the effect of rural youths' migration on maize production in Kontagora Local Government Area of Niger State, Nigeria. The specific objectives were to; describe the socio-economic characteristics of farmers; ascertain the causes of youths' migration, determine the extent of youths' migration, access the effect of youths' migration on maize production and identify the problems associated with youths' migration in the area. To achieve these objectives, 120 maize farmers were randomly selected through multi-stage sampling technique. Data were analyzed using descriptive statistics and multiple regression analysis. The result on socio-economic characteristics shows that majority (52.5%) of the respondents are still in their active age of between 21- 40 years with mean age of 39years. Equally, respondents were males (72.5%), married (77.5%) with Non formal education (40%). Only a few (18.3%) attained tertiary education. Similarly, majority (90%) had a household size of between 1 – 10 persons with average size of 6 persons per household. The average maize farming experience among the respondents was 17 years. The major causes of youths' migration in the area includes: lack of employment opportunities (90%), furthering of education (77.5%), and lack of access to modern amenities (55%). The extent of Youths migration in the area is relatively moderate (45.8%) with averagely 31 youths leaving each village every year. The peak period of migration is usually during the off-season (50.8%). The result of the regression analysis shows Cob-Dougllass as the lead equation. The result revealed that youths' migration affect production negatively while labour, agro chemicals and fertilizer are positively significant. The problems of youths migration in the area include; loss of cultural values (75%), reduction in rural population (54.2%) and dull village life (47.5). To this end, youths' migration limits maize production thus, government should provide functional schools and employment opportunities to engage rural youths.*

**KEYWORDS:** migration, rural-urban drift, Regression model

## INTRODUCTION

Nigeria was previously an agricultural economy when farming sector contributes to the majority of her total export. The income and revenue obtained from farming sector was sufficient to not only cater for the farmers' needs but also sustain the Government (Adejugbe, 2004). The rural areas accounted for the bulk (75%) of the Nigerian farming activities. To this end, Nigeria was among the largest producers of cocoa, groundnut, palm oil and rubber thereby, generating revenue for the development of several infrastructures and educational institution like Ahmadu Bello University of Zaria and Obafemi Awolowo University of Ife, two of the best learning institutions in the present era. However, the discovery of crude oil and its subsequent exploration and exportation in 1970's brought setback to Nigeria agricultural sector as government shifted their attention to the easy money-making oil industry at the expense of Agricultural development. Consequently, rural youths were tempted to move to the urban centers where they can have their own

share of the national cake. This act of movement of people away from their current place of living to another geographical area is known as '**migration**'. Thus, movement of people from the rural area to the urban centre is called '**rural-urban migration**' (Tacoli, 1998).

The Movement away from the places of origin of either on a permanent or a temporary nature had become an option to improve the life chance of a wider spectrum of the population of developing countries especially farm youths (Solomon, 2005). Therefore, migration is an economic choice where individuals or households decide to migrate to other areas, if there is a higher anticipated income. By implication, migration results in response to rural-urban dissimilarities in anticipated rather than actual incomes (Okhankhuele, 2013), The basic premise is that migrants consciously deliberate on the various opportunities or labour market prospects accessible to them between the rural and urban sectors, and select the one which maximizes their anticipated gains or benefit from migration. Hence, the movement of

people from the rural to urban centres can be seen as a spontaneous human reaction or effort to achieve balance between population and resources. Ofuoku (2015) pointed out that, one of the main effects of rural-urban migration is the shortage of labour supply needed for farming activities. Rural-urban pattern of migration takes more young men than the aged people out of the rural areas, leaving the few elderly men and women as well as children whose effort in farming operation is limited (Eliss and Harris, 2004).

Presently, Nigeria like most African countries is at a stage where it realized that proficiency in rural development depends on sustained growth in rural incomes and standard of living derived primarily from agriculture (De Haan *et al.*, 2002). In view of the above drive, this study seeks to achieve the following objectives:

- (i) describe the socio-economic characteristics of the farmers,
- (ii) examine the causes of rural-urban migration in the study area,
- (iii) determine the extent of rural-urban migration,
- (iv) determine the effect of youths' rural-urban migration on maize production,
- (v) identify the problems associated with youths' migration in rural areas.

## METHODOLOGY

### Area of Study

This study was conducted in Kontagora Local Government Area (LGA) of Niger State, Nigeria. The Area covers approximately 2,179 km<sup>2</sup> lands mass and a projected population size of 185,698 people (Niger State Bureau of statistics (NSBS), 2016). The Area is located between longitude 10<sup>0</sup> and 24<sup>0</sup> North and latitude 5<sup>0</sup> and 28<sup>0</sup> East. It is bordered by Rijau LGA to the north; Mashegu LGA to the south; Magama and Mariga LGA to the west and east, respectively. Kontagora LGA has distinct dry and wet seasons with an average annual rainfall of about 1,300mm. The Area is divided into thirteen (13) major Communities with farming as the major occupation of the people.

### Sampling Technique and Sample Size

The sample population for this study consisted of mainly maize farmers in Kontagora LGA of Niger State. A multi-stage sampling technique was used to select the respondents for this study. The first stage involved random selection of six (6) out of the 13 rural communities in the study area. The second stage involves selection of registered maize farmers (as sample frame) from each of the selected communities. While the third stage, involves random

selection of 20% of the registered farmers as the sample size of the study. A total of 120 farmers were considered as respondents for this study.

### Method of Data Collection

Primary data were utilized for this study. The data were obtained using a structured questionnaire and interview schedule.

### Method of Data Analysis

Data were analyzed by means of descriptive statistics such as frequency counts, percentages and multiple regression analysis. The multiple regression analysis was utilized to examine the effect of rural-urban migration on maize production.

### Model Specification

#### Multiple regression model

Multiple regression model - shows the relationship between a dependent variable and combination of independent variables. The value of dependent variable is defined as a combination of independent variables plus error term.

Thus, the implicit form of the regression model is stated as:  $Y=f(X_1, X_2, X_3, \dots, X_n, e_i)$  (i)

In this study, four (4) regression functions were tested in order to determine the best fit. The explicit forms of the four (4) functional models were expressed as:

1. Linear:  $Y = a + \beta_1 X_1 + \beta_2 X_2 + \beta_3 X_3 + \beta_4 X_4 + \beta_5 X_5 + \beta_6 X_6 + e$
2. Semi-log:  $Y = a + \beta_1 \ln X_1 + \beta_2 \ln X_2 + \beta_3 \ln X_3 + \beta_4 \ln X_4 + \beta_5 \ln X_5 + \beta_6 \ln X_6 + e$
3. Double-log:  $\ln Y = a + \beta_1 \ln X_1 + \beta_2 \ln X_2 + \beta_3 \ln X_3 + \beta_4 \ln X_4 + \beta_5 \ln X_5 + \beta_6 \ln X_6 + e$
4. Exponential:  $\ln Y = a + \beta_1 X_1 + \beta_2 X_2 + \beta_3 X_3 + \beta_4 X_4 + \beta_5 X_5 + \beta_6 X_6 + e$

Where:

$Y_i$  = Total maize output (Kg)

$\beta_1 - \beta_6$  = Parameters to be estimated

$X_1 - X_6$  = independent variables. Where;

$X_1$  = Migration (number of migrants per household)

$X_2$  = farm labour (Man days)

$X_3$  = Agro chemicals (liters)

$X_4$  = Quantity of seed (kg)

$X_5$  = Fertilizer (kg)

$X_6$  = Land (hectares)

$a$  = Constant

$e$  = Error term

## RESULTS AND DISCUSSION

### Socio-economic Characteristics of the Respondents

Socio-economic characteristics influence the thought, feelings and behaviors of farmers towards making decisions in their daily farming operations. Some of these attributes includes gender: which help to identify



the involvement of males and females in farming operations, age, marital status, educational status, household size and farming experience. Therefore, the results in Table 1 revealed that majority (52.5%) of the respondents were between the ages of 21 – 40 years with a mean age of 39 years. This implies that, the respondents were still in their active age and therefore constitute readily available labour supply for maize production. This result corroborate with the findings of Obidike (2015) who reported that, the average age of respondents among farmers in Abia State was 40years. The Table also reveals that majority (72.5%) of the respondents were males, while female farmers in the area accounted for 27.5% of the population. This is perhaps due to the cultural and religious belief that tends to restrict females to household keeps rather than participating in farming activities. This result is also consistent with the findings of Obidike (2015) who reported that majority of rural farmers who tend to migrate to urban centers of Abia State were male.

Equally, majority (77.5%) of the respondents were married thus, farm households are likely to have large labour supply for farming activities. This result corroborate with the findings of Ofuoku (2015) who pointed out that, married persons were more involved in farming activities due to higher food demand in the household. Furthermore, the result revealed that all the respondents had one form of education or the other. However, majority (40%) of the respondents had Non formal type of education related to skills acquisition and training while 18% of the respondents attended tertiary education. Meaning that, there is low literacy level in the study area. This finding agreed with Olajide and Udoh (2012) who reported that personal characteristic especially, education influences adoption of new technology and when it is lacking among farmers decrease in innovation adoption rate and low production may result.

In the same vein, the result revealed that majority (90%) of the respondents had a household size of between 1– 10 persons with average size of six (6) persons per household. This implies that the respondents had a fairly large family size and by implication large family labour for farming. This finding corroborate with the result of Gimba (2004) who reported that, the average household size among the migrant maize farmers in Maiduguri Metropolis was eight (8) persons.

In terms of maize farming experience, the respondents had fairly large years of experience as majority (52.5%) of the respondents had been into maize production for 8 – 21 years. The average farming experience among the respondents was 17 years. This finding thus, conforms to the traditional assertion that ‘every rural person is a farmer from birth’.

### **Causes of Rural Youths Migration**

In other to ascertain the causes of rural youths drift, a collection of factors were presented to the respondents: the options were as presented in Table 2. The Table shows a mix results ranging from educational, political, and socio-economic factors. Majority (90%) of the respondents were of the opinion that, youths in their community migrate to the urban centres in other to secure employment particularly, the more paying and less stressful white-collar job that is often lacking in rural areas. This implies that most of the migrants have formal Education certificate or training that could secure their livelihood outside farming thus, seek greener pasture in the cities. Similarly, 77.5% of the respondents believed that youths migrate to the cities in other to further their education which has necessitated by the ineffective schools and learning facilities in most villages. Other respondents (55%) reported lack of social amenities as the driving force behind rural-urban migration. Meaning that; youths whom constitute the literate class of the community wish to enjoy access to social infrastructures which are grossly inadequate in the rural areas. This result agrees with the findings of Okhankhuele (2013) who reported that, people migrate to cities in other to further their Education, to seek for employment opportunities and to enjoy recreational amenities.

### **Extent of Rural Youths Migration**

The extent of out migration describes the level and peak period of youths migration to urban centres.

The result in Table 3 revealed split opinion among the farmers on the level of youths’ migration. While majority (45.8%) of the respondents described youths’ migration in their village to be moderate others (25.8%) believed that it is on the high side with averagely 31 youths leaving each village every year. It therefore implies that maize farmers in the study area are feeling the pressure of losing their loved ones to the cities hence, considers it as threat to family labour supply. This result corroborate with the findings of Adejugbe (2004) who reported that, with averagely twenty (20) persons leaving the village yearly to settle in the urban areas, farmers’ access to family labour is grossly limited. Similarly, majority (50.8%) of the respondents observed that, the peak period of migration in their village is during the off-season when farming activities are being put to rest due to lack of rain fall. This finding is further supported by the 28.3% of the respondents who stated that, most youths migrated to the cities immediately after completing their studies. This is perhaps due to the strong determination of youths to pursue more educational qualification that will afford them life outside farming through white-collar job. This result



conforms to the findings of Olajide and Udoh (2012) who reported that, migrants are often reluctant to return to their villages in spite of the problems perceived in the cities and would rather that the government used motorbikes and other experimental development programs as instruments of poverty reduction instead of farm inputs.

#### **Effect of Youths Migration on maize Production**

The results of the regression model showing the effect of youth's migration on maize production were as presented in Table 4. From the regression analysis result, output of the double-log regression gave the best fit based on the significance of the F-value, the value of the coefficient of determination ( $R^2$ ), number and signs of significant parameters estimated in conformity with the aprior expectation. The R-Square ( $R^2$ ) value of 0.7842 shows that 78.42% variation in the maize farmers' production were explained by the independent variables included in the model.

The result also revealed that youths' migration was negatively significant at 10% probability level. While labour, agro chemicals and fertilizer were all positively significant at 1% level of probability. This shows that increase in youths migration to urban areas will result to decrease in maize production. In other words, the loss of a single youth to urban area will result to 0.17kg probability decrease in the quantity of maize grain produced. This is perhaps due to the fact that majority of the rural maize farmers in the practices subsistence production system hence; greatly depend on the family labour for cultivation. This is in agreement with the finding of Ofuoku (2015) who reported among other reasons that rural families keeps larger household members in other to meet with the labour requirement of cultivating larger farm size. The result further indicates that farm labour had a significant and positive effect on maize production in the area. Meaning that, a day increase in farm labour will result to 0.39kg probability increase in maize output. Similarly, agro chemical is positively significant to maize production thus; continuous application of agro chemicals in maize farm will lead to increase in the quantity of output produced. By implication, one liter increase in agro chemical application will result to 0.53kg probability increase in the quantity of output generated by the farmers. Equally, fertilizer had a significant and positive effect on maize production therefore; one kilogram (1kg) increase in the quantity of fertilizer application will result to 0.19kg probability increase in the quantity of maize produced. These findings is in line with the apriori expectations of the study which tend to consider labour, agro chemicals and fertilizer as important factors required for maize production. In the same vein, the result corroborate with the findings of

Adesiyan (2015) and Adaku (2013) who reported that labour, agro chemicals and fertilizer are the main determinant of crop farmers' productivity in rural areas.

#### **Problems of Rural-Urban Migration**

Rural-urban migration has long been recognized as a great challenge in the developmental effort of the rural areas (Olajide and Udoh, 2012). Government programmes to improve the rural people and regulate rural-urban drift had yielded mix result, particularly now that human population is increasing at geometric pace as against arithmetic increase in food production (Okhankhuele, 2013). Some major problems of rural-urban migration in the study area were as presented in Table 5. These problems include loss of cultural values (75%) which ranked highest, followed by decrease in rural population (54.2%) and dull village life (47.5%). This implies that, with continuous migration of rural youths to the urban centers, the entire social life of the rural people is threatened. Youths whom are presumably the future of every community are less available for the smooth transfer of cultural values. These perhaps are the main reasons for loss of cultural identity in some of the rural areas in the country. This result agrees with the findings of Okhankhuele (2013) who reported that, out-migration of youths in large number has led to a dull village life since youths were no longer available to help parents carry out domestic chores and family vocation thereby, resulting in decreased production and living condition among rural dwellers.

#### **CONCLUSION AND RECOMMENDATIONS**

It is an appreciable fact that rural-dwellers in kontagora Local Government Area of Niger State are fully involved in maize production. Thus, youths' migration is in response to the socio-economic deprivation existing in the area which tends to threaten not only the sustainability of cultural values but also the economy development of the community, especially, maize farming enterprise. To this end, public authorities and educational stakeholders should collaborate to establish functional Schools, skill acquisition centres and workshops in rural areas. This will go a long way to reducing youths migration to the urban centres searching for knowledge and skills that will empower them to acquire white collar job. Similarly, social infrastructures and loans should be made available by those in authority and financial institutions so as to bridge the social gap in living condition between rural and urban dwellers.

Table 1: Socio economic Characteristics of the respondents

<b>Variables</b>	<b>Frequency (120)</b>	<b>Percentage (%)</b>	<b>Mean</b>
<b>Age</b>			
20 and below	9	7.5	39
21 – 40	63	52.5	
41 – 60	44	36.7	
61 and above	4	3.3	
<b>Gender</b>			
Male	87	72.5	
Female	33	27.5	
<b>Marital status</b>			
Married	93	77.5	
Single	21	17.5	
Divorced	4	3.3	
Widow	2	1.7	
<b>Educational Status</b>			
Non formal	48	40	
Primary Education	17	14.2	
Secondary Education	33	27.5	
Tertiary Education	22	18.3	
<b>Household size</b>			
10 and below	108	90.0	6
11 – 15	10	8.3	
16 and above	2	1.7	
<b>Maize farming experience</b>			
7 and below	21	17.5	17
8 – 14	31	25.8	
15 – 21	32	26.7	
Above 21 years	36	30.0	

Source: ICAAT, 2018

Table 2: Distribution of respondents based on the causes of rural-urban migration

<b>Causes of Migration</b>	<b>Frequency (120)</b>	<b>Percentage (%)</b>	<b>Rank</b>
Further education	93	77.5	2 <sup>nd</sup>
To secure employment	108	90	1 <sup>st</sup>
Lack of social amenities	66	55	3 <sup>rd</sup>
Find partner for business	22	18.3	7 <sup>th</sup>
Natural disaster	28	23.3	6 <sup>th</sup>
Change of environment	48	40	4 <sup>th</sup>
Marriage	29	24.2	5 <sup>th</sup>

Source: ICAAT, 2018

Table 3: Distribution of respondents based on the extent of youths' migration in the study area

<b>Parameters</b>	<b>Frequency (120)</b>	<b>Percentage</b>	<b>Average num of migrants per village</b>
<b>Level of migration in the area</b>			
Low	34	28.3	31
Moderate	55	45.8	
High	31	25.8	
<b>Period of peak migration</b>			
During festivals/elections	6	4.2	
During planting season	13	10.8	
Immediately after harvest	61	50.8	
After acquiring vocational training	7	5.8	
After acquiring educational qualification	34	28.3	

Source: ICAAT, 2018



Table 4: Functional forms of multiple regression analysis on effect of rural–urban migration

Variables	Linear	Semi-Log	Double-log	Exponential
Migration	-135.164 (-1.06)	-220.9455 (-1.20)	-0.1656325 (-1.70*)	-0.030089 (-0.33)
Farm labour	5.214618 (2.44***)	351.5758 (1.66*)	.3903902 (3.49***)	.0062227 (4.05***)
Agro chemical	85.45699 (4.59***)	728.3588 (4.24***)	0.5332885 (5.87***)	0.0533042 (3.98***)
Seed	-2.635642 (-1.15)	-74.00239 (-0.37)	-0.0070767 (-0.07)	-0.0016207 (-0.98)
Fertilizer	0.8893374 (1.76*)	517.0963 (3.57***)	.1939732 (2.53***)	0.0003991 (1.10)
Land	238.3197 (1.97**)	88.87863 (0.57)	-0.063606 (-0.77)	0.0437035 (0.50)
Constant	151.9428 (0.67)	-3844.332 (-3.18***)	3.574919 (5.58***)	6.211076 (37.93***)
R-squared	0.7858	0.7188	0.7842	0.6972
F-value	69.09***	48.14***	68.42***	43.36***

NOTE: \* = Significant at 10%    \*\* = Significant at 5%    \*\*\* = Significant at 1%  
 Source: ICAAT, 2018

Table 5: problems of rural-urban migration

Problem of Migration	Frequency (n = 120)	Percentage (%)	Rank
Dull village life	57	47.5	3 <sup>rd</sup>
Decrease in rural population	65	54.2	2 <sup>nd</sup>
Uneven development	40	33.3	6 <sup>th</sup>
Decrease in family labour	54	45	4 <sup>th</sup>
Loss of cultural values	90	75	1 <sup>st</sup>
Reduction in annual farm income	48	40	5 <sup>th</sup>
Low farm productivity	38	31.7	7 <sup>th</sup>

Source: ICAAT, 2018

## REFERENCES

- Adaku, A. A. (2013). The effect of rural-urban migration on agricultural production in the northern region of Ghana. *Journal of Agricultural Science Application*, 2(4), 193–201.  
<http://doi.org/10.14511/jasa.2013.020402>
- Adejugbe, M. A. (2004): Industrialization, Urbanization and Development in Nigeria: An Introduction in Industrialization, Urbanization and Development in Nigeria 1950-1999. Concept Publications Limited. pp. 11, 15-16.
- Adesiyun, A. T. (2015). Economic Analysis of Maize Production in Osun State: A Case Study of Ilesa East and West of Osun State. *Journal of Economics and Sustainable Development* 6(9), 268-279.
- De Haan, A. & Rogally, B. (2002): Migrant Workers and their Role in Rural Change. *Journal of Development Studies*. 38(5), 1 – 14.
- Eliss, F. & Harris, N. (2004). In New Agriculturist on-Line: *Reporting Agriculture for the 21<sup>st</sup> Century*. 1<sup>st</sup> September 2004. p.1. <http://www.new-ag.info/04-5/dev.1.html>.
- Gimba, Z. (2004). Causes and Effects of Rural-Urban Migration in Borno State : a Case Study of Maiduguri Metropolis, *Asian Journal of Business Management Science*. 1(1), 168-172.
- Niger State Bureau of Statistics (NSBS), (2013). Online: Retrieved from [https://www.citypopulation.de/php/nigeria\\_admin.php?adminid=NGA027:21](https://www.citypopulation.de/php/nigeria_admin.php?adminid=NGA027:21) March, 2016
- Obidike, P. C. (2015). Managing rural-urban migration and brain drain for sustainable economic recovery in Nigeria: Constraints and options. *International Business Management Journal*, 1(1), 1-7.
- Ofuoku, A. (2015). Effect of rural-urban migrants' remittances on arable crop production in Delta State, Nigeria. *Journal of Agricultural Sciences, Belgrade*, 60(1), 49–59.
- Okhankhuele, O. T. (2013). Causes and Consequences of Rural-Urban Migration Nigeria : A Case Study of Ogun Waterside Local Government Area of Ogun State , Nigeria . *British Journal of Arts and Social Sciences*», 16(I), 185–194.
- Olajide, A., & Udoh, G. (2012). Rural-Urban Migration: Migrants Perceptions of Problems and Benefits in Oyo State Nigeria, *Journal of Agricultural Extension and Rural Development*, 187–191.
- Solomon, K. (2005): *Housing Development as Instrument to Alleviate Urban Poverty: The case of Addis Ababa*. At the International Conference for Integrating Urban Knowledge and Practice, Gothenburg, Sweden, May 29 to June 3, 2005.
- Tacoli, C. (1998). Rural-urban interactions : a guide to the literature. *Environment & Urbanization* 10(1): 147-166.

## PROXIMATE COMPOSITION, MICRONUTRIENT AND SENSORY PROPERTIES OF COMPLEMENTARY FOOD FORMULATED USING SOME SELECTED CEREALS

Okwori, E.,

. National Agricultural Research Extension and Liaison Services (NAERLS), Ahmadu Bello University (A.B.U), Zaria, Nigeria.

\*Correspondence: estherokwori777@yahoo.com. Phone: 07068798168

### ABSTRACT

*This study was conducted to formulate an affordable blend based on the locally available cereals within the environment, chemically evaluate their respective nutritive values and assess the acceptability of the product developed using four organoleptic attributes. An improved complementary food consisting of Rice, soybeans and groundnut was formulated with rice serving as the food base. Standard procedures of Association of Official Analytical Chemists were used to determine the proximate chemical composition while atomic absorption spectrophotometer was used to determine the mineral element composition. Sensory evaluation to test their acceptability was assessed with 10 panelists using four organoleptic attributes. The result showed carbohydrate was the highest calorific contributor in the sample as it contained  $50.24 \pm 0.06$  of carbohydrate followed by lipids, protein moisture and the ash and fiber contents of the sample was obtained to be  $1.40 \pm 0.77$  and  $0.51 \pm 0.13$ . Micronutrient concentration, Calcium was found to be the most abundant mineral element ( $7075 \text{mg/kg}$ ) followed by magnesium and iron with the concentration of  $352.5 \text{mg/kg}$  and  $26.0 \text{mg/kg}$  respectively. The moisture content was  $4.51 \pm 0.03$  and the ash and fiber contents of the sample were  $1.67 \pm 0.24$  and  $0.74 \pm 0.14$ . The sample contain all the vitamins tested for (vitamin C, B6 and A). The product was acceptable to the assessors. It meets the consumers' sensory attributes and high in both macro and micro nutrient content. The research concluded that complementary food products formulated from cereal, rice, soybeans and groundnut can meet both the micro and macro nutritional needs of infants and young children. Mothers and caregivers can source this item within their localities to solve the problem of malnutrition. Formulated diets had nutritional superiority in terms of protein, ash, fat and total energy (kCal) composition.*

**KEYWORDS:** Complementary food, Proximate Composition, Micronutrient, Sensory

### INTRODUCTION

Breast milk alone is the ideal start to a child's life; breast milk can continue to be an important source of nutrients until the child is at least two years old. To keep a young child healthy during this period, complementary foods should be nutritious, clean and safe and fed in adequate amounts. These foods given in addition to breast milk are called complementary foods. The process of feeding them is called complementary feeding. Many infants and children suffer from malnutrition, not because of the economic status but because parents lack the knowledge to utilize the available resources within the environment to meet their daily needs. (Ojinnaka et al., 2013). Childhood malnutrition is prevalent in many parts of the world, especially in developing countries like ours. Protein, energy and micronutrient malnutrition are the commonest forms. Micronutrients malnutrition in infants and young children became a major concern to public health nutrition just before the World Summit for Children in the late 80's (Solomon, 2000). Adequate

processing and judicious blending of locally available foods could result in improved intake of nutrients to prevent malnutrition problems. Wheat, rice; groundnut and soybean are readily available foods in Nigeria. They have promising nutritional attributes. The crude protein content of most legumes varies between 16.0% in groundnut to 35.1% in soybeans. Soy protein is limiting in essential Sulphur containing amino acids (methionine, cysteine, etc.), but rich in lysine and tryptophan (FAO 1992). Complementary foods in developing countries are often low in fat and essential fatty acids, which are required for growth and development. Adequate breastfeeding and complementary feeding practices are fundamental to infant's nutrition, health, and survival during the first two years of life. Infant feeding in the early years of life influences an individual's whole life. Therefore, the nutritional adequacy of complementary foods is essential for the prevention of infant morbidity and mortality, including malnutrition and overweight. Complementary feeding usually begins at 6 months and continues up to the age of 24 months when



transition from exclusive breastfeeding to semi-solid foods begins. It is at this stage that the nutritional requirements of many infants are not met, thus leading to the onset of malnutrition that is prevalent in children under 5 years of age worldwide (Daelmans and Saadeh, 2003). Traditional weaning foods in Nigeria and other parts of Africa is made up of single or one type of grains prepared from millet, maize or sorghum into gruels known as “Akamu” which is not adequate nutrition wise. Formulation of complementary foods using available and affordable staple food commodities is a possible approach that has been recommended to reduce malnutrition. This study was conducted to formulate some affordable composite blends based on the locally available cereals within the environment, and chemically evaluate their respective nutritive values. The study also examines the acceptability of the product developed using four organoleptic attributes with a five hedonic scale

## METHODOLOGY

Procurement and processing of the Complementary Diets: wheat, rice, Soybean and rice grain were purchased at the Samaru market Zaria. Experiments were conducted to formulate complementary food from Rice, soybean and ground nut. Productions of rice, soya bean, groundnuts flours, were sorted separately, cleaned, washed and blanched for 45 min. They were deshelled and toasted for 30 min. The toasted grains and nuts were then oven dried at 60°C for 15 min, milled and sieved to fine flours. The sample were milled separately and formulated as follows: Rice-Soybean- groundnut consisting of 80% rice flour, 10% soybean flour, 10% groundnut, and the flours were packaged separately and sealed with food grade polyethylene bags (100g) stored in the refrigerator till further use and analysis.

Composite blends were formulated from common rice, soya bean and groundnut. Standard procedures of Association of Official Analytical Chemists (AOAC) were used to determine the proximate chemical composition while atomic absorption spectrophotometer was used to determine the mineral element composition. Sensory evaluation to test their acceptability was assessed with 10 panelists using four organoleptic attributes with a six-point hedonic scale. The products were evaluated for proximate composition and organoleptic assessment.

## Statistical analysis

Results were expressed as mean  $\pm$  standard deviation, descriptive and inferential analytical statistics using SPSS statistical package. The results of sensory evaluation were reported in percentages.

## RESULTS AND DISCUSSION

In developing countries, complementary foods are mainly based on starchy tubers like cassava, cocoyam and sweet potato or on cereals like maize. (Hellstrom et al, 1981). Supplementation of cereals with locally available legumes increases the protein content of cereal-legume blends and their protein quality through mutual complementation of their individual amino acids (Muhimbula et al 2011). (Ojofeitimi EO et al., 2010,).

Results for the proximate composition of food (complementary food) used in the study are presented in Tables 1-12. The moisture content of the sample was obtained to be  $4.02 \pm 0.03$ . The protein and lipids contained in the sample are  $22.68 \pm 0.24$  and  $26.09 \pm 0.25$  respectively. The carbohydrate level was the highest calorific contributor as it contained  $50.24 \pm 0.06$  of carbohydrate. The ash and fiber contents of the sample were obtained to be  $1.40 \pm 0.77$  and  $0.51 \pm 0.13$ . Micronutrient, concentration Calcium was found to be the most abundant mineral element present in the sample with the concentration of 7075mg/kg followed by magnesium and iron with the concentration of 352.5mg/kg and 26.0mg/kg respectively. All the vitamins tested for (vitamin C, B6 and A) are present in the sample. In the weaning period, the iron requirements in relation to energy intake are the highest of the lifespan and the rapidly growing weaning infant has no iron stores and has to rely on dietary iron (FAO/WHO, 2001). A lack of sufficient micronutrients in the diet affects the health and development of children and results in potentially life-threatening deficiency diseases such as anemia and vitamin A deficiency (FAO, 2001). A positive calcium balance is required throughout growth, particularly during the first two years

of life and children of this age group are always at risk of calcium deficiency (FAO/WHO, 2001). The sample contain all the vitamins tested for (vitamin C, B6 and A) are present in the sample. Sensory evaluation color, taste, mouth feel and texture of the sample shows 10.5% , 21.1%, 15.8% of the population like moderately for taste, color and texture and 21.1% for mouth feel and flavor while 10.5% dislike moderately. FAO/WHO (2001) reported that special emphasis should be placed on the micronutrient composition, nutrient bioavailability and utilization of local diets and also in the way these foods are actually consumed by the people. (Solomon, 2005, FAO/WHO, 2001)

## CONCLUSION AND RECOMMENDATIONS

The research concluded that complementary food products formulated from cereal, rice, soybeans and groundnut can meet both the micro and macro nutritional needs of infants and young children. The product conformed to FAO/WHO requirements with respects to protein, energy and micronutrients contents. It has acceptable sensory attributes Mothers and caregivers can source this item within their localities to solve the problem of malnutrition. Formulated diets had nutritional superiority in terms of protein, ash, fat and total energy (kCal) composition. The formulated complementary food can be used to combat the problem of malnutrition among infants and children in Nigeria and other developing countries.



**Table 1: Proximate composition of Rice Mix Meal**

Parameter	Taste	Color	Texture	Mouth feel	Flavor	Acceptability
Parameter	Values (%)					
Moisture	4.02±0.03					
Ash	1.40±0.77					
Lipid	26.09±0.25					
Protein	22.68±0.24					
Fibre	0.51±0.13					
CHO	50.24±0.06					

Values are expressed as Mean ± Standard Deviation (SD)

**Table 2: Photochemical and anti-nutritional factors of Rice Mix Meal**

Anti-nutritional factor	Concentration (%)
Phytate	0.19
Tannin	1.00
Oxalate	0.36
Saponin	16.50
flavonoids	86.37

**Table 3: Mineral Concentration of Rice Mix Meal**

Parameter	Concentration (mg/kg)
Calcium (Ca)	7075
Magnesium (mg)	352.5
Iron (Fe)	26.0
Zinc (Zn)	0.00

**Table 4: Vitamin Analysis of Rice Mix Meal**

Parameter	Result
Vitamin C	+
Vitamin B6	+
Vitamin A	+

**KEY** + = Present and - Absent

**Table 5: Sensory properties of Rice Mix Meal**



	F	%	F	%	F	%	F	%	F	%	F	%
Dislike	2	10.5			2	10.5	2	10.5	3	15.8	3	15.8
Dislike extremely	1	5.3	1	5.3	1	5.3	1	5.3	1	5.3	1	5.3
Dislike moderately	1	5.3			1	5.3	1	5.3	1	5.3	1	5.3
Neither like nor dislike					1	5.3			2	10.5	1	5.3
Like slightly	2	10.5	3	15.8	4	21.1	5	26.3	1	5.3		
Like moderately	3	15.8	3	15.8	4	21.1	4	21.1	4	21.1	6	31.6
Like extremely	6	31.6	8	42.1	2	10.5	2	10.5	3	15.8	3	15.8
Total	15	78.9	15	78.9	15	78.9	15	78.9	15	78.9	15	78.9
Missing system	4	21.1	4	21.1	4	21.1	4	21.1	4	21.1	4	21.1
Total	19	100.0	19	100.0	19	100.0	19	100.0	19	100.0	19	100.0

## REFERENCES

- Anigo K. M., Ameh, D. A. Ibrahim. S. and Danbauchi S. S. (2009). Nutrient composition of commonly used complementary foods in North western Nigeria. *African Journal of Biotechnology* Vol. 8 (17), pp. 4211-4216, 1 September, Available online at <http://www.academicjournals.org/AJB> DOI: 10.5897/AJB09.253 ISSN 1684-5315 © 2009 Academic Journals
- AOAC (2005). Official methods of analysis of Association of Official Analytical Chemists International (18 ed.). Gaithersburg, Maryland, USA: AOAC International
- Daelmans B, Saadeh R (2003). Global initiatives to improve complementary feeding. In: Moreira (eds) Meeting the challenge to improve complementary feeding. SCN News United Nations System Standing Committee on Nutrition, Lavenham Press, UK. pp. 10-17
- FAO/WHO, (2001). Energy and Protein Requirements. Report of a joint FAO/WHO. Expert consultation. WHO Tech. Report Series No. 74: 86-98.
- Gazhim, S., Bintu, B.P., Modu, S., Falmata A.S. and Zainab M.K., (2015). Effects of feeding a complementary diet formulated from rice, Banjara beans and sesame on in vitro studies in weaning rats. *Merit Research Journal of Food Science and Technology*. 3(1): 001-005.
- Hellstrom A, Hermansson AM, Karlsson A, Liungquist B, Melander D and Solomon M (2005). Nutritive Value of three potential complementary foods based on cereals and legumes. *African. Journal. Food. Nutrition. Science*. 5(2): 1-14.
- Muhimbula HS, Issa-Zacharia A and Kinabo J (2011). Formulation and sensory evaluation of complementary foods from local, cheap and readily available cereals and legumes in Iringa, Tanzania
- Nnam, N.M., (2002). Evaluation of complementary foods based on maize, Groundnut, pawpaw and mango fruit flour blends. *Nigerian Journal Nutrition Science* 22 & 23:8-18
- Obinna-Echem PC, Kuri V, Beal J (2015). Effect of processing method on the mineral content of Nigerian fermented infant complementary food-Akamu. *LWT – Food Sci. Technol.*, 61: 145-151.
- Ojofeitimi EO, Afolabi OA, Fapojuwo, Grissom FEG and Oke OL. (2010). The use of black-eyed cowpeas, maize-gruel mixture ("ewa-ogi") in the treatment and prevention of infantile protein malnutrition. *Nutrition Reports International* 1984; 30
- Solomon's NW (2000). Micronutrient deficiencies and contamination. *Nutrition. Environment. J* 2(1): 14-17.
- Developing countries FAO/WHO (2001). Human vitamin and mineral requirements. Report of a joint FAO/WHO Expert Consultation. Bangkok, Thailand. Food and Nutrition Division, FAO Rome. pp. 7-8.
- Svanberg U. (2005) Dietary bulk as a limiting factor for nutrient intake in pre-school children. II. Consistency as related to Dietary Bulk – A model study. *J. Trop. Paediatric*; 27: 127.
- UNICEF (2001). Situation Assessment and Analysis. In: Hodges (eds) Children's and Women's Rights in Nigeria: A Wake-up call. National Planning Commission, Abuja and UNICEF, Nigeria.

## PALATABILITY AND ACCEPTABILITY STUDY OF SPROUTED SORGHUM AS AN IMPROVED CEREAL CROP FOR HOUSEHOLD USE

<sup>1</sup>Okwori, E., <sup>2</sup>Gaminana. Z. <sup>1</sup>Onu, R.O., and <sup>1</sup>Mustapha, A.K

<sup>1</sup> National Agricultural Research Extension and Liaison Services (NAERLS), Ahmadu Bello University (A.B.U), Zaria, Nigeria.

<sup>2</sup> Samaru College of Agriculture, Division of Agricultural Colleges, Ahmadu Bello University (A.B.U), Zaria, Nigeria.

\*Correspondence: estherokwori777@yahoo.com.Phone: 07068798168

### ABSTRACT

*The study was conducted on sprouted sorghum as an improved cereal crop to check for its palatability and acceptability. Standard procedures of Association of Official Analytical Chemists were used to determine the proximate chemical composition and Sensory evaluation to test their acceptability was assessed with 20 panelists using four organoleptic attributes with 7-point hedonic scale. Results indicated that the sample had highest acceptability and palatability quantities at 20% ad sprouting showed a significant increase at ( $p < 0.05$ ) in proximate composition of level of proteins. A significant reduction was seen in the level of fat, ash and fiber content also substitution with sorghum bran did not alter the physical characteristics and consumer acceptability of cookie sample at 20% substitution level. SSB incorporation in cookie production was found to help to substantially reduce foreign exchange on wheat importation and reduce wastage of by-products in production.*

**KEYWORDS:** Sorghum, Sprouted, Acceptability, Palatability, Substitution

### INTRODUCTION

Cereals supply the bulk of the food eaten by the human race. They are the cheapest source of food energy and has a calorie percentage and protein intake of man particularly in developing countries commonly cultivated cereals are wheat, rice, rye, oats, corn and sorghum.

Sorghum is a cereal crop that is grown in semi-arid zones of Africa, Asia and South America because of its drought tolerance. It is the fifth most important world cereal, followed by wheat, maize, rice and barley (Zohard., 2000). Sorghum contains some nutrients such as carbohydrate, protein, lipids, minerals and vitamins. However, they are made unavailable for use by the body because of the presence of some anti-nutritional factors such as phytic acid and polyphenols (Chavan & Kadan, 1993).

Germination processes have been developed to overcome these disadvantages of sorghum in food products (Zohard, 2000). Germination which also means sprouting is a complex metabolic process during which lipids, carbohydrate and storage proteins within the seeds are broken down to obtain the energy and amino acid necessary for the plant's development (Malomo et al., 2013). Germination or sprouting is a common problem for grain during harvest when the weather is moist or when the environment is humid during storage. Germination promotes the development of cytolytic, proteolytic

and amylolytic enzymes that are not active in dry kernels (Bamforth, 2006; Dewar et al., 1997; Klose et al., 2009) and could cause significant changes in kernel composition and physical properties (Zohard, 2000). It's in this light that the study is conducted to examine the nutrient composition of Sorghum before and after sprouting, evaluate the physico-chemical and organoleptic qualities of sprouted Sorghum on the palatability and acceptability for household utilization. Palability of food or fluid, unlike its flavor or taste varies with the state of an individual that is it is lower after consumption and higher when deprived. Palability of foods however can be needed and it has increasingly been appreciated that this can create a hedonic hunger that is independent of homeostatic needs (Wikipedia, 2017). Food acceptability is the measure of whether an individual will consume enough food to meet his/ her calorie needs.

### METHODOLOGY

Standard procedures of Association of Official Analytical Chemists were used to determine the proximate chemical composition and Sensory evaluation to test their acceptability was assessed with 20 panelists using four organoleptic attributes with 7-point hedonic scale.

Materials used are Composite flour, Sprouted Sorghum, Margarine, Sugar, Egg, Baking powder, Salt.

### Preparation of Cookies



**Cookies Recipe;** Flour- 250g, margarine-100g, sugar-100g, egg-1, baking powder-10g, pinch of salt.

**Procedure:** Mix cream butter and sugar until soft and fluffy; add beaten egg and cream, mix all the dry ingredients with composite flour (wheat flour), rub-in the flour, mold to shape and bake in 150°C, preheated oven for about 30mins to golden brown.

#### Formulation of composite flour

The composite flour was prepared by replacing sprouted sorghum flour (SSF) with wheat flour (WF) at 20%, 40%, 60%, 80%, 100% and were labelled as samples; T0, T1, T2, T3, T4 and T5 respectively. Sample T0 with 100% SSF served as a reference sample. The sorghum bran was sorted to remove whole sorghum grains and then winnowed to remove stones and other foreign materials. The winnowed grains were soaked for 24 hours, rinsed and strained. It was covered and left at room temperature to sprout; the sprouting grain was rinsed with clean water after every 12 hours to prevent fermentation. The Sprouting processing was closely monitored pictures and measurements of the sprouts were taken until fully sprouted after 48 hours. The sprouted sorghum was dried under room temperature for about 72 hours and milled into flour. The sprouted sorghum flour and commercial wheat flour were weighed separately with the aid of a digital electronic weighing balance (Metra, model TL 600) at different proportions to make composite for cookies.

#### Flow Chart for Preparation



#### Determination of proximate compositions of sorghum flour

Sorghum flour was analyzed for moisture, protein, fat, crude fiber and ash contents according to the methods described in Association of Official Analytical Chemists [AOAC] (2005). The total carbohydrate (CHO) was calculated by difference method as: CHO = (%moisture + %protein + %fat + %ash). Food energy value (kcal/100 g) was determined according to the method of Marero et al. (1998) using the factor (4 × %Protein) + (4 × %Carbohydrate) + (9 × %Fat)

#### Determination of physical characteristics of the cookies

##### Weight

The weight of the cookies was determined according to the method of (Nkama and Adeworie, 2007). The weights of cookie samples were determined with the aid of a weighing balance (model) immediately after cooling.

##### Diameter

The diameter (D) of the cookies was determined according to the method of AACC (2000). Four cookies were placed edge to edge and their total diameter was measured with the aid of a ruler. The cookies were rotated at angles of 90° for duplicate reading. The experiment was repeated twice and average diameter was recorded in millimeter.

##### Thickness

The thickness of the cookies was determined according to the method of Ayo et al. (2007). The cookies thickness was measured with the aid of a digital Vernier caliper with 0.01 mm precision.

##### Spread ratio

Spread ratio of the cookie samples was determined according to the method of Monyo (1997). For spread ratio, two rows of four well-formed cookies were made and the height measured. They were arranged horizontally edge to edge and the sum of their diameters measured. The spread ratio was calculated as diameter divided by height, using the formula below;

$$SF = \frac{D \times CF \times 1.0}{T}$$

Where, CF is a correction factor at constant atmospheric pressure. It has a value of 1.0 in this case (AACC, 2000).

##### Breaking strength

The breaking strength was determined according to the method described by Okaka and Isiehs (1997). Cookies of known thickness (0.4 cm) were placed centrally between two parallel metal bars (3 cm apart) and weights were applied until the cookies snapped. The least weight that caused the breaking of

the cookies was regarded as the break strength of the cookies.

### **Sensory evaluation of the cookies**

Sensory evaluation of the cookies was carried out according to the method described by Retapol and Hooker (2006). A panel of twenty members was chosen based on their familiarity and experience with wheat-based cookies for sensory evaluation. Cookies produced from each flour blend, along with the reference sample were presented in coded form on white plastic plates and were randomly presented to each household. The households were provided with portable water to rinse their mouth between evaluations. However, a questionnaire describing the quality attributes (colour, taste, flavour, crispiness and overall acceptability) of the cookies was given to each household. The households assigned scores for each parameter as against the maximum score of 7. Each sensory attribute was rated on a 7-point hedonic scale (1 = dislike extremely and 7 = like extremely).

### **Data Analysis**

Quantitative data was done using the Statistical Package for Social Sciences (SPSS 20). For objectives 1 and 2 descriptive statistics, namely percentages, frequency and ANOVA for the sensory evaluation of cookies from sprouted sorghum flour were used.

## **RESULTS AND DISCUSSION**

The results of the effect of sprouted sorghum flour on the proximate compositions of cookies are presented shows, the moisture content (%) of the cookies ranged between 3.34 and 4.06. The reference sample (T0) had the least value while cookie sample (T1) had the highest value. However, increased substitution level with WF caused significant ( $p < 0.05$ ) reduction in the moisture content values. The moisture content of the cookies was low enough (<10%) to reduce the chances of spoilage by micro-organisms and consequently guarantee good storage stability (Ayo et al., 2007). The findings showed that the moisture content of the cookie samples decreased with increasing substitution levels with WF. On the contrary, Gernah et al. (2010) reported higher moisture content (5.20–9.30%) for cookies made from sprouted sorghum-brewers spent grain flour blends.

**Ash content** of the cookies ranged from 1.41 to 1.88% for the reference sample (T0) and cookie sample (T4) respectively. The addition of sorghum flour significantly ( $p < 0.05$ ) increased the ash content of the cookies progressively. Ash content of a food material is an indication of the mineral constituent's present. (Adebowale, Olayiwola, & Maziya-Dixon, 2008). It aids the metabolism of other compounds such as fat, protein and

carbohydrate (Okaka&Ene, 2005, Omeire & Ohambele 2010, Giwa & Abiodun, 2010).

**The protein content** of the sprouted sorghum ranged from 11.21 to 15.64%; cookie sample (T4) had the highest protein content (15.64%) while the reference sample (T0) had the lowest (11.21%). Addition of SS caused significant ( $p < 0.05$ ) increase in the protein content of the cookies. The observed increase could be attributed to the significant quantity of protein (12.5%) in barley bran. The findings conform with the report of Giwa & Ikuenlorta, 2010, Giwa & Abiodun., 2010, Ayo, Mkama & Adeworie, 2006, Adebowale et al.,2012).

**The fat content (%)** of the cookies ranged between 29.86 and 32.36%. Cookie sample (T4) had the highest fat content (32.36%) while the reference sample (T0) had the least value (29.86%).

The fat content of the cookies increased significantly ( $p < 0.05$ ) as the substitution level increased from 5 to 50% with malted barley bran. The finding agrees with Omeire & Ohambele (2010) and Gernah et al. (2010) on their reports for the increasing trend in the fat content of the cookies produced from wheat-defatted cashew nut and wheat-brewers spent grain (2.52–4.80%) flour blends respectively. The presence of high fat content in the cookies means high calorific value and also serves as a lubricating agent that improves the quality of the product, in terms of flavour and texture (Giwa & Abiodun, 2010).

**The crude fibre content** of sprouted sorghum ranged from 1.32 to 6.38%; sprouted sorghum flour sample (T4) had the highest value (6.38%) while the reference sample (T0) had the lowest value (1.32%). Sprouted sorghum flour has relatively higher crude fibre content than wheat and this justify the results obtained for the sorghum samples. The increasing trend in the crude fibre content of the sprouted sorghum flour could be a reflection of its composition that is reported to be 13.9% (Satinder et al., 2011). The finding conforms to the observation Akinwande et al., (2008) for the increasing trend in the crude fibre (1.32–10.82%) contents of cookies made from wheat-brewers spent grain flour blends. The presence of high fibre in food products is essential owing to its ability to facilitate bowel movement (peristalsis), bulk addition to food and prevention of many gastrointestinal diseases in man (Satinder et al., 2011, Omeire & Ohambele, 2010).

**Carbohydrate content** of the sprouted sorghum ranged between 40.05 and 52.79%. Sprouted sorghum flour sample (T4) had the lowest carbohydrate content (40.05%) while the reference sample (T0) had the highest value (52.79%). The increase in proportion of wheat flour brought about decrease in the carbohydrate content of the sprouted sorghum flour. Similarly, a decreasing trend in the



carbohydrate contents (73.46– 46.20%) and (70.45– 23.71%) of sprouted sorghum flour made from wheat-brewers spent grain flour blends and whole wheat- full fat soya flour blends was reported by Nagaraj et al. (2013). The low carbohydrate content and increased fibre content of the composite cookies have several health benefits, as it aids digestion in the colon and reduces constipation often associated with products from refined grain flours (Elleuch et al., 2011)

**The energy value** of the sprouted sorghum ranged between 509.98 and 525.05 kcal/100 g; cookie sample (T3) had the lowest energy value, while the reference sample (T0) had the highest value. The energy values of the composite cookies were significantly ( $p < 0.05$ ) different from the reference samples. Similarly, a decreasing trend in the energy value (443.89–431.95 kcal) for cookies made from wheat and quality protein maize was reported by Giwa and Ikujenlola (2010).

#### **Sensory characteristics of cookies**

The results of the sensory assessment of cookies produced from sorghum flour blends are presented in Table 4. The mean scores of colour, taste, flavor, crispiness and overall acceptability for the cookies were significantly different ( $p < 0.05$ ) from one another. The reference sample had the highest scores for all the attributes observed, except for colour and crispiness. The mean score for the cookies colour ranged between 7.1 and 8.4. Cookie sample (T1) had the lowest value while sample (T4) had the highest value. Generally, the scores for cookies colour increased as the substitution level of malted barley bran increased. This could be attributed to the dark brown coloration of the cookie samples with incorporation of 20–100% WF as compared with that of the reference sample as well as the coarser texture of the former compared with the latter.

The intense brown colour of the composite cookies could be due the presence of high amount of carbohydrate in the flour blends, thus resulting in caramelized product. In addition, this could be an indication that substitution of sorghum bran with sorghum flour for cookie making actually provides more protein for Maillard reaction to take place, which is normally encountered and desirable in baked goods. Moreover, the change in colour with increasing substitution level of WF might be due to nutrients interaction during processing and baking temperature and time combination. The results are in accordance with the findings of Giwa and Abiodun, 2010, Akpapunam and Darbe (1994) who observed that darker colour of cookies may be due to the non-enzymatic reaction (Maillard reaction) between reducing sugar molecules and lysine protein.

Based on taste, the scores for the cookies ranged from 4.1 to 7.6; cookie sample (T4) had the lowest value while the reference sample (T0) and sample (T1) had the same high value (7.6). The astringent taste observed among the cookie samples could be attributed to the development of bitter substances, owing to the presence of tannin in sorghum bran. From the result, it could be deduced that up to 20% substitution level wheat flour could be acceptable by consumers with a mean score of 7.6. The mean scores for flavor ranged between 4.3 and 8.3 for cookie sample (T4) and the reference sample (T0) respectively. However, there was a decrease in the aroma scores of the cookie samples with increase in the substitution level of WF. No significant differences ( $p > 0.05$ ) exist between cookie samples; T2 and T3 respectively. The scores for the texture of cookies ranged from 5.2 to 8.2; cookie sample (T5) had the lowest value while sample (T1) had the highest value. There was no significant difference ( $p < 0.05$ ) between 20 and 100% substituted cookie samples. The mean scores (5.4–8.8) for the overall acceptability of the cookies were above the average (4.5), indicating high acceptability of the cookie samples. The reference sample (T0) had the highest value, while cookie sample (T5) had the least value. The possible reason for low acceptability of the cookie samples produced with WF substitution level above 20% could be due to the observed dark brown coloration and bitter taste. It is therefore clear according to the result that substitution of sorghum bran up to 100% substitution level could produce good cookies that are even more acceptable than the reference sample with excellent attributes. Notes: Mean value with different subscripts on the same row are significantly different ( $p \leq 0.05$ ); SSF–Sprouted sorghum flour; WF– wheat flour; T0–100% SSF–0% WF; T1–80% SSF–20% WF; T2–60% SSF–40% WF; T3–40% SSF–80% WF; T4–20% SSF–100% WF; T5- WF-100%

The mean scores (5.5–7.8) for the overall palatability of the cookies were above the average (4.5), indicating high palatability of the cookie samples. The reference sample (T4) had the highest value, while cookie sample (T0) had the least value. The possible reason for low palatability of the cookie's samples produced with WF substitution level above 20% could be due to the observed dark brown coloration and bitter taste. It is therefore clear according to the result that substitution of wheat flours up to 100% substitution level could produce good cookies that are even more palatable than the reference sample wit

#### **CONCLUSION AND RECOMMENDATIONS**

Sprouting showed a significant ( $p < 0.05$ ) increase in the proximate composition in the level of Proteins



and a significant reduction was observed in the level of fat, ash and fiber content. Processing significantly increase in vitro Protein digestibility and this could be due to the reduction in the tannin level especially in the Sprouted Sample. Sprouting reduced to the nearest minimum level of proximate composition. The results vividly showed that it could be possible to produce palatable and acceptable cookies through the substitution of sprouted sorghum flour with sorghum bran. The high protein, ash and fiber contents of cookies made from sorghum bran substitution as well as the acceptability of the composite cookies attested to this fact. The results also showed that substitution with sorghum bran did not alter the physical characteristics and consumer acceptability of the cookie samples especially at 20% substitution level. In conclusion, therefore, 20% SSB incorporation in cookies production could help to substantially reduce foreign exchange on wheat importation and reduce wastage of the by-product, while improving the nutritional status of consumers. Germination should be encouraged as it promotes the development of cytolytic, proteolytic and amylolytic enzymes that are not active in dry kernels and enhances the taste of food.



Table 1: Composition of Sorghum before and after sprouting

	Moisture	Ash	Protein	Oil	Fibre	Carbohydrate	Total Energy
Before	7.46	1.55	9.28	2.27	2.34	85.20	376.9
After	7.54	1.33	11.63	2.33	4.84	81.91	372.4

Table 2: Effect of Processing on proximate Composition of Sorghum Flour

Proximate compositions of (%) of sorghum flour						
Moisture	Ash	Crude protein	Fat	Fibre	Carbohydrate	Energy value Kcal/100
3.34 <sup>e</sup>	1.41 <sup>e</sup>	11.21 <sup>e</sup>	29.86 <sup>d</sup>	1.32 <sup>e</sup>	52.79 <sup>a</sup>	
4.06 <sup>a</sup>	1.53 <sup>d</sup>	11.86 <sup>d</sup>	30.76 <sup>c</sup>	3.41 <sup>d</sup>	48.41 <sup>b</sup>	
3.78 <sup>b</sup>	1.62 <sup>c</sup>	13.17 <sup>c</sup>	30.76 <sup>c</sup>	4.24 <sup>c</sup>	46.43 <sup>c</sup>	
3.75 <sup>c</sup>	1.75 <sup>b</sup>	14.68 <sup>b</sup>	30.78 <sup>b</sup>	5.48 <sup>b</sup>	43.56 <sup>d</sup>	
3.65 <sup>d</sup>	1.88 <sup>a</sup>	15.63 <sup>a</sup>	32.36 <sup>a</sup>	6.38 <sup>a</sup>	40.05 <sup>e</sup>	

Table 3: Shows the Effect of Processing on Proximate Composition of Sprouted Sorghum

Proximate compositions of (%) of sprouted sorghum flour						
Moisture	Ash	Crude protein	Fat	Fibre	Carbohydrate	Energy value Kcal/100
3.34 <sup>e</sup>	1.41 <sup>e</sup>	11.21 <sup>e</sup>	29.86 <sup>d</sup>	1.32 <sup>e</sup>	52.79 <sup>a</sup>	525.02 <sup>a</sup>
4.06 <sup>a</sup>	1.53 <sup>d</sup>	11.86 <sup>d</sup>	30.76 <sup>c</sup>	3.41 <sup>d</sup>	48.41 <sup>b</sup>	517.79 <sup>b</sup> 00
3.78 <sup>b</sup>	1.62 <sup>c</sup>	13.17 <sup>c</sup>	30.76 <sup>c</sup>	4.24 <sup>c</sup>	46.43 <sup>c</sup>	515.24 <sup>c</sup>
3.75 <sup>c</sup>	1.75 <sup>b</sup>	14.68 <sup>b</sup>	30.78 <sup>b</sup>	5.48 <sup>b</sup>	43.56 <sup>d</sup>	509.98 <sup>e</sup>
3.65 <sup>d</sup>	1.88 <sup>a</sup>	15.63 <sup>a</sup>	32.36 <sup>a</sup>	6.38 <sup>a</sup>	40.05 <sup>e</sup>	514.00 <sup>d</sup>

Table 4: Shows the Mean scores for the sensory evaluation of cookies produced from sprouted sorghum flour and wheat flour (Sensory attributes of cookies)

Sample	Taste	Aroma	Colour	Texture	Overall acceptability	Palatability
T <sub>5</sub>	7.8 <sup>a</sup>	8.5 <sup>a</sup>	7.0 <sup>e</sup>	5.0 <sup>f</sup>	5.2 <sup>f</sup>	5.3 <sup>f</sup>
T <sub>4</sub>	7.6 <sup>b</sup>	8.3 <sup>b</sup>	7.3 <sup>d</sup>	7.7 <sup>b</sup>	8.8 <sup>a</sup>	7.8 <sup>a</sup>
T <sub>3</sub>	7.6 <sup>b</sup>	7.8 <sup>c</sup>	7.1 <sup>e</sup>	8.2 <sup>a</sup>	8.2 <sup>b</sup>	7.4 <sup>b</sup>
T <sub>2</sub>	7.1 <sup>b</sup>	6.5 <sup>d</sup>	7.5 <sup>b</sup>	5.3 <sup>d</sup>	7.3 <sup>c</sup>	7.0 <sup>c</sup>
T <sub>1</sub>	6.3 <sup>c</sup>	6.5 <sup>d</sup>	7.4 <sup>c</sup>	5.7 <sup>c</sup>	6.3 <sup>d</sup>	6.1 <sup>d</sup>
T <sub>0</sub>	4.1 <sup>e</sup>	4.3 <sup>d</sup>	8.4 <sup>a</sup>	5.2 <sup>e</sup>	5.4 <sup>e</sup>	5.5 <sup>e</sup>

## REFERENCES

- Akinwande, B. A., Ade- Omowaye, B. I. O., Olaniyan, S. A., & Akintaro, O. O. (2008). Quality evaluation of ginger flavored soy-cassava biscuit. *Nutritional and Food Science Journal*, 38, 473–481.
- Akpapunam, M. A., & Darbe, J. W. (1994). Chemical composition and functional properties of blends of maize and Bambara groundnut flours for cookie production
- Ascroft J., (1973). The overall evaluation of the special rural development plan. Geneva. Institute for Social Development.
- Association of Official Analytical Chemists [AOAC]. (2005). Official methods of analysis (16th Ed.). Washington, DC: Author.
- Ayo, J. A., Ayo, V. A., Nkama, I., & Adeworie, R. (2007). Physicochemical, invitro digestibility and organoleptic evaluation of acha-wheat biscuit supplemented with soybean flour. *Nigerian Food Journal*, 25, 15–17.
- Chavan, J. K., & Kadam, S. S. (1993). Nutritional enrichment of bakery products by supplementation with non-wheat flours. *Critical Reviews In Food Science and Nutrition*, 33, 189–226.  
<http://dx.doi.org/10.1080/10408399309527620> Chemistry, 124, 411– 421.
- Elleuch, M., Bedigian, D., Roiseux, O., Besbes, S., Blecker, C., & Atta, H. (2011). Dietary fibre and fibre-rich by-products of food processing: Characterization, technological functionality and commercial applications. *Review of Food*
- FAO (Food and Agricultural Organization of the United Nations) and ICRISAT (International Crops Research Institute of the Semi-Arid Tropics) (1996). The world sorghum economies: facts, trends and outlook. FAO, Rome, Italy and ICRISAT.
- Giwa, E. O., & Abiodun, I. V. (2010). Quality characteristics of biscuits produced from composite flours of wheat and quality protein maize. *African Journal Food Science*, 1, 116–119.
- Giwa, E. O., & Ikujenlola, A. V. (2010). Quality characteristics of biscuits produced from composite flours of wheat and quality protein maize. *African Journal of Food Science and Technology*, 1, 118–119.
- Nagaraj N, Basavaraj G, Parthasarathy Rao P, Bantilan C, Halder S, (2013). Sorghum and pearl millet economy of India – future outlook and options. *Econom Political weekly XLVIII (52): 74 – 81.*
- Wikipedia, (2006/2017). Sorghum. Wikipedia, the Free Encyclopedia.  
<http://en.wikipedia.org/wiki/Sorghum>
- Zohary, D., and M. Hoof. 2000. Domestication of Plants in the Old World, 3rd edition. Oxford: University Press. ISBN 0198503571



**NUTRIENT DIGESTIBILITY AND CARCASS CHARACTERISTICS OF WEANER RABBITS  
(*Oryctolagus cuniculus*) FED GRADED LEVELS OF BOILED PELLETED NEGRO COFFEE (*Senna  
occidentalis*) SEED MEAL.**

Kudu, Y.S., M.J. Ibrahim, A. O. Abdulmalik and A. A. Malik.

Department of Animal Production, Federal University of Technology, Minna, Nigeria.

Corresponding Author's e-mail: [ibrahimmj@futminna.edu.ng](mailto:ibrahimmj@futminna.edu.ng), GSM: 08036020469

#### ABSTRACT

A 12 week feeding trial was conducted to determine the nutrient digestibility and carcass characteristics of weaner rabbits fed boiled pelleted senna *occidentalis*. A total of forty-five weaner rabbits of mixed sexes were randomly divided into five treatment groups in a completely randomized block design with three replicates of three rabbits each. Boiled senna *occidentalis* was included in the diets at the levels of 0%, 2.5%, 5%, 7.5% and 10% respectively. Although a significant difference ( $p < 0.05$ ) observed in the result of feed intake and feed conversion ratio, they however decreased linearly with increasing levels of senna in the diet. Weekly weight gain was highest in Treatment 4 (7.5% boiled pelleted senna) from the fourth week till the end of the experiment while Treatment 5 (10% senna) recorded the lowest throughout the experiment. Treatment 1 had the highest digestibility values for crude protein and fat while Treatment 4 had the highest value for crude fibre, although significant variation ( $p < 0.05$ ) occurred among all the parameters taken (Nutrient Digestibility and Carcass Characteristics). Significant difference ( $p < 0.05$ ) occurred in the live weight, slaughter weight and dressed weight. The weight of the dressed external parts and the internal organs showed significant difference ( $p < 0.05$ ). Better performance parameters were obtained in Treatment 4 indicating that up to 7.5% boiled senna can be included in the diets of growing rabbits without any adverse effects.

**KEYWORDS:** Boiled Pelleted *Senna occidentalis* seeds, Digestibility, Carcass

#### INTRODUCTION

Rabbit production is becoming more attractive among the tropical farmers because of its numerous desirable traits which include: ability to convert plant feed materials into high quality protein, high growth rate (when compared to other livestock like goat, sheep, pig and cattle), high fecundity, short generation period, good source of organic manure for farmers and high adaptability to varying climatic extremes among others (Mailafia *et al.*, 2010).

The cost of the conventional feed stuffs has continued to increase tremendously in recent times and as livestock production continues to increase to meet the growing population of the world, the availability of these conventional feed stuffs is often fickle. This challenge has been worsened by the rising competition between man and livestock for these conventional feedstuffs (Odunsi, 2003). Feed forms the most important component in livestock production and if not provided in the right quality and quantity, the amount and quality of livestock products will reduce and there will be limited supply of animal protein to meet the human needs. Non-conventional feedstuffs generally refer to those feed stuffs that are not traditionally used for feeding livestock and are not used commercially to produce animal feeds. Several known examples of these

feedstuffs among others are negro coffee, palm leaf meals, palm press fibre, seeds and leaves of *gmelina arborea* (gmelina) and cassava foliage. The objective of this study is to determine the potentials of *Senna occidentalis* (Negro coffee) as feed material and the performance of rabbit fed on coffee. Abdullahi *et al.* (2003) reported that the use of negro coffee is limited due to poor information on its nutritional values and the presence of anti-nutritional factors such as phytates, cyanide, saponnins, trypsin inhibitor, tannins and anthroquinones coupled with its pungent smell.

#### MATERIALS AND METHODS

Forty-five mixed sexed rabbits were used for this study while the *senna occidentalis* seeds were harvested from the matured shrub stands in the wild along the roads. *Senna* pods collected were well dried and threshed to get the seeds which were then winnowed and cleaned to remove dirt. The cleaned seeds were then boiled using the method described by Omoikhoje *et al.* (2009) which was adopted by Yahaya (2014); the seeds were subjected to boiling at 100<sup>o</sup> C for 60 minutes and then removed and dried. The boiled dried seeds were milled using hammer mill to get a fine texture and was labelled boiled *senna occidentalis* seed meal (BSOSM) and then

stored. Anti-nutritional factors such as cyanide, tannin content, saponnin, phytic acid, trypsin inhibitor activity of both boiled and raw *senna* seeds were determined at the National Cereals Research Institute, Badegi using the methods of Onwuka (2005). Formulated feeds were pelleted using pelleting machine of 2mm screen size to prevent waste of feed during feeding and it was served *ad-libitum*. The proximate analysis of the feed and fecal samples was carried out using AOAC (2000) standard methods to determine the quality and nutrients in the feed such as the (Dry matter (dm), Crude protein (cp), Crude fiber (cf) Ether extract (ee), and Ash ) and the nutrients voided out through the feces to establish the nutrient intake.

## RESULTS AND DISCUSSION

Table 1 shows the effects of boiling on the anti-nutritional factors present in the raw seeds. Tannins recorded the highest percentage reduction of 78.38% while saponnin recorded the lowest percentage reduction of 24.74%. Table 2 shows the feed composition of the experimental diets. The crude protein ranges from 17.99% in T2 to 18.09% in T4. The performance parameters are shown in Table 3. Average feed intake recorded significant differences ( $p < 0.05$ ) between treatments for all the weeks with the values decreasing with increasing levels of *senna* in the diet. The feed conversion ratio also followed similar trend with significant differences observed among all the treatments throughout the experiment except at weeks 4, 5 and 8. Midala *et al.* (2013) and Tasaka *et al.* (2000) also reported similar decrease in feed intake and feed conversion ratio (FCR) with higher levels of *senna* in the diets. This could be as a result of higher residual effects of anti-nutritional factors. The result for the nutrient digestibility is shown in Table 4. Rabbits on the control diet had the highest digestibility values for crude protein, crude fat and nitrogen free extract which are necessary for growth and energy respectively. Rabbits on Diet 4 (7.5% boiled *senna occidentalis* seed meal) had the second highest digestibility values for crude protein and crude fibre. Diet 5 had the highest value for dry matter. There was however a significant difference among all parameters taken. The carcass result shown in Table 5 indicates that rabbits on Diet 4 (7.5 % boiled *senna occidentalis* seed meal) recorded the highest values for live weight, slaughter weight, empty body weight and dressed weight. This result is contrary to the results obtained by Midala *et al.* (2013) which revealed that performance variables and carcass weights decreased as the level of raw seeds increases in the diet from 2.5% to 10%. This could be

**Table 1: Anti-nutritional factors of raw and boiled *Senna occidentalis* seeds**

attributed to the high amounts of anti-nutritional factors present in raw seeds. Ogunlade *et al.* (2011) reported that anti-nutritional factors like tannin can affect the availability of amino acids and the utilization of protein thereby depressing growth. The significant difference in the weight of internal organs and external parts is in accordance with the results obtained when raw seeds were fed to rabbit by Midala *et al.* (2013). Final weight gain was highest in rabbits from Treatment 4 fed (7.5%) inclusion level of (boiled *senna occidentalis* seed meal) from the fourth week of the experiment till the end of the experiment. This reveals that nutrients were not just digested but were also optimally absorbed and assimilated to aid body growth and weight gain. Amy (2010) had reported that rabbits if fed balanced ration are efficient converters of feed to meat, however, Midala *et al.* (2013) had reported that performance of rabbits fed raw *senna* seeds decreased linearly with increasing level of *senna* in the diet. This contradiction could be as a result of high amount of anti-nutritional factors in raw *senna*. However, at 10% inclusion of boiled *senna occidentalis* seed meal in the diet, rabbits recorded the lowest weight gain from the inception of the experiment till the end even though they had recorded the highest digestibility value for dry matter. This could be as a result of possible effect of residual anti-nutritional factors present in the diet. Shaahu *et al.* (2014b) had stated that although the digestion of a diet may be good but the utilization can be poor due to impaired absorption; which can be due to the presence of certain anti-nutritional factors like phytohaematoglutinins, which exert a non-selective adverse effect on the absorption of nutrients from the intestinal tract rather than a direct effect on the digestive process. However, poor digestion in this case may also be attributed to higher levels of saponnin content. Tannins reduce feed intake by decreasing palatability of diets because of its astringent effect on oral cavity. It also forms complex with certain enzymes of the digestive tract seriously affecting utilization of carbohydrates and proteins and resulting in decreased growth, feeding efficiency, metabolizable energy and availability of amino acids (Onyango *et al.*, 2005).

## CONCLUSION

Based on the results of this study, it can be concluded that boiled *senna occidentalis* seed meal had no adverse effect on the carcass characteristics and nutrient digestibility of rabbits. This result shows also that boiled *senna occidentalis* seed meal can be included up to 7.5 % in the diets of growing rabbit without any adverse effect.

Anti-nutritional factors	Raw	Boiled	% Reduction
Cyanide (mg/100g)	18.30	7.06	61.42
Phytate (mg/100g)	518.25	332.18	35.90
Tannin (g/kg)	25.86	5.59	78.38
Saponin (mg/100g)	32.10	24.16	24.74
Trypsin inhibitor (g/kg)	35.72	15.41	56.86

**Table 2: Feed composition and calculated nutrient values of experimental diets on dry matter basis**

Ingredients (%)	DIETS				
	1	2	3	4	5
Maize	36.00	36.50	37.00	37.00	37.50
Soybean	27.00	25.00	24.00	24.00	20.00
Blood meal	2.45	2.45	2.45	2.5	2.0
BSOSM	0.00	2.50	5.00	7.50	10.00
Rice offal	18.00	17.00	18.00	16.45	17.95
Maize offal	13.00	13.00	10.00	9.00	9.00
Bone meal	2.50	2.50	2.50	2.50	2.50
*Premix	0.25	0.25	0.25	0.25	0.25
Salt	0.40	0.40	0.40	0.40	0.40
Methionine	0.20	0.20	0.20	0.20	0.20
Lysine	0.20	0.20	0.20	0.20	0.20
Total	100	100	100	100	100
<b>Calculated nutrients</b>					
Crude protein (%)	18.05	17.99	18.08	18.09	18.00
Energy kcal/kg	2992.17	3000.05	3002.63	3002.78	3017.26
Crude fibre (%)	12.23	12.21	11.74	10.87	11.32
Calcium (%)	1.16	0.98	1.13	1.02	0.94
Phosphorus (%)	0.62	0.62	0.61	0.58	0.53

\*To provide the following per 100kg of the diet :440mg riboflavin, 720mg calcium,2g pantothenate, 2g niacin, 2.2g chloride, 15mg folic acid, 1mg vitamin B12, 15mg retinol,165mg vitamin D2, 1000mg DL-tocopherol acetate, 1700mg copper, 200mg iodide, 3000mg manganese, 5000mg zinc, 10,000mg iron.

\*BSOSM: Boiled *Senna occidentalis* seed meal

**Table 3: Growth performance of weaner rabbits fed graded levels of pelleted boiled *Senna occidentalis* seed meal**

Parameters	DIETS					SEM	LS
	1	2	3	4	5		
Init. body weight (g)	546.67 <sup>a</sup>	548.33 <sup>a</sup>	548.33 <sup>a</sup>	548.33 <sup>a</sup>	546.67 <sup>a</sup>	20.35	NS
Final body weight (g)	1175.00 <sup>bc</sup>	1200.00 <sup>bc</sup>	1410.00 <sup>ab</sup>	1550.00 <sup>a</sup>	1053.30 <sup>c</sup>	119.42	**
Av.d.body wt gain (g)	7.48 <sup>bc</sup>	7.66 <sup>bc</sup>	10.26 <sup>ab</sup>	11.94 <sup>a</sup>	6.03 <sup>c</sup>	1.40	**
Av.d. feed intake (g)	56.50 <sup>a</sup>	53.34 <sup>b</sup>	45.51 <sup>c</sup>	43.93 <sup>c</sup>	40.48 <sup>d</sup>	0.97	**
FCR	7.88 <sup>c</sup>	6.96 <sup>bc</sup>	4.47 <sup>ab</sup>	3.78 <sup>a</sup>	7.20 <sup>c</sup>	1.16	**

<sup>abc</sup>Means with different superscripts showed significant differences (p<0.05)

Av.d =Average daily, FCR=Feed conversion ratio, Init= Initial weight.



**Table 4: % Nutrient digestibility of rabbits fed graded levels of pelleted boiled *Senna occidentalis* seed meal (BSOM)**

Parameter	DIETS					SEM	LOS
	1	2	3	4	5		
Dry matter	77.33 <sup>ab</sup>	73.85 <sup>b</sup>	79.80 <sup>a</sup>	77.84 <sup>ab</sup>	80.59 <sup>a</sup>	2.19	*
Crude Protein	82.74 <sup>a</sup>	78.13 <sup>b</sup>	78.67 <sup>ab</sup>	78.78 <sup>ab</sup>	76.88 <sup>b</sup>	1.99	*
Crude Fibre	69.09 <sup>b</sup>	73.22 <sup>ab</sup>	72.51 <sup>ab</sup>	78.66 <sup>a</sup>	76.13 <sup>ab</sup>	3.19	*
Ether extract	77.39 <sup>a</sup>	76.81 <sup>ab</sup>	73.98 <sup>abc</sup>	71.72 <sup>c</sup>	72.72 <sup>bc</sup>	2.06	*
Ash	63.68 <sup>c</sup>	74.42 <sup>b</sup>	75.48 <sup>b</sup>	82.13 <sup>a</sup>	84.22 <sup>a</sup>	2.74	*
NFE	89.38 <sup>a</sup>	84.14 <sup>b</sup>	85.93 <sup>ab</sup>	84.90 <sup>ab</sup>	83.49 <sup>b</sup>	2.13	*

<sup>abc</sup>Means with different letters show significant difference (p<0.05), NFE: Nitrogen Free Extract,

1 = 0 % BSOSM, 2 = 2.5 % BSOSM, 3 = 5.0 % BSOSM, 4 = 7.5 % BSOSM, 5 = 10.0 %

\*= Significant difference, LOS=Level of significance, SEM= Standard error of mean.

**Table 5: Carcass characteristics of rabbits fed boiled *Senna occidentalis* seed meal**

Parameter	T1	T2	T3	T4	T5	SEM	LOS
LV weight(g)	1200.00 <sup>b</sup>	1216.70 <sup>b</sup>	1450.00 <sup>a</sup>	1600.00 <sup>a</sup>	1100.00 <sup>b</sup>	102.20	*
SL weight (g)	1150.00 <sup>bc</sup>	1116.70 <sup>c</sup>	1350.00 <sup>ab</sup>	1450.00 <sup>a</sup>	1050.00 <sup>c</sup>	102.20	*
EM weight(g)	1000.00 <sup>ab</sup>	850.00 <sup>b</sup>	1050.00 <sup>ab</sup>	1150.00 <sup>a</sup>	833.30 <sup>b</sup>	86.28	*
DR weight (g)	622.98 <sup>dc</sup>	651.99 <sup>c</sup>	758.03 <sup>b</sup>	912.84 <sup>a</sup>	538.61 <sup>d</sup>	40.28	*

<sup>abc</sup>Means with different letters show significant difference (p<0.05).

SL weight=slaughter weight, \*= Significant difference, LV weight = Live weight, EM weight = Empty weight, DR weight = Dressed weight.

#### ACKNOWLEDGEMENTS

The Almighty God and the Department of Animal Production, Federal University of Technology, Minna, and National Cereals Research Institute, Badegi are acknowledged.

Midala, D.B., Augustine, C., Moses, J.D., and Jimruna, E.Y. (2013). Response of growing rabbits to graded levels of *Senna occidentalis* seedmeal and Cost Benefit of using *Senna occidentalis* seedmeal as feedstuff for rabbits. *International Journal of IT, Engineering and Applied Sciences Research (IJIEASR)* Volume 2, No. 8, August 2013.

#### REFERENCES

Abdullahi, M., Mohammed, G., Abdulkadir, N.U. (2003). Medicinal and economic plant of Nupe. Bida, Niger State, Nigeria.: Jube Evans Books Publications.

Odunsi A.A (2003). Assessment of lablab (*Lablab pruriens*) leaf meal as a feed ingredient and yolk colourings agent in the diet of layers. *International journal of poultry science*, 2(1):71-74.

Amy, H.E. (2010). M.Sc. Nutritional Requirements for Rabbits, October, 2010 – Monogastric nutritionist Shur-Gain, Nutreco Canada Inc.

AOAC (2000). Association of Official Analytical Chemists. Official methods of analysis, vol. 1, 17th edition. AOAC, Arlington, VA, USA.

Ogunlade, I., Ilugbiyin, A., and Osasona, A. I. (2011). A comparative study of proximate composition, anti- nutrient composition and functional properties of *Pachira glabra* and *Azelia africana* seed flours. *African Journal of Food Science*, 5 (1), 32-35.

Mailafia, S.I., Onakpa, M.M. and Owoleke O.E. (2010). Problems and prospects of rabbit production in Nigeria. *Bayero Journal of Pure and Applied Sciences*. Volume 3(2): 20-25.

Omoikhoje, O., Aruna, M.B., and Bambgbose, A.S. (2009). Effect of cooking on some anti-

nutrient component of Bambara roundnut seeds. *Journal of Animal Science* , 52-56.

Onwuka, G.I.(2013).Food analysis and instrumentation, theory and practice, printed by Naphthali prints, A division of Hg support, Nigeria Limited, Surulere, Lagos, Nigeria.pg 140-153.

Onyango, C., Noetzold, H., Ziem, A., Hofmann, T., Bley,T., and Henle, T. (2005). Digestibility and anti-nutrient properties of acidified and extruded maize-finger millet blend in the production of Uji. *LWT, Food Science and Technology* 38: 697-707.

Shaahu, D.T., Carew S.N., and Dzungwe N.E. (2014b). Effect of using raw or processed Lablab seed as major protein source in diets on the economics of feeding and growth performance of rabbits. *IOSR Journal of agriculture and Veterinary Science ((IOSR-JAVS) Vol.7, issues 5 ver. 1 (May, 2014) pp22-26.*

Tasaka, A.C., Weg, R.,Calore, E.E., Sinhorini, I.I., Dagli, M.I.Z., Haraguchi, M. and Gorniak, S.I. (2000). Toxicity testing of *Senna occidentalis* seed in rabbits. *Veterinary Research Communication* 24(8)573-582.

Yahaya, S.K. (2014). Performance and biochemical profile of wild indigenous guinea fowl fed differently processed Negro coffee (*Senna occidentalis*) seed meal under intensive system management. Ph.D Thesis submitted to the Postgraduate School , Federal University of Technology, Minna.

## OCCURRENCE AND DISTRIBUTION OF MAIZE STEM BORERS IN SOME SELECTED LOCAL GOVERNMENT AREAS OF NIGER STATE, NIGERIA

Oyewale<sup>1</sup>, R.O., Salaudeen<sup>1</sup>, M.T., Bamaiyi<sup>2</sup>, L.J., Bello<sup>1</sup>, L.Y., Usman<sup>1</sup>, M.B. & Adeyemo<sup>1</sup>, J.M.

<sup>1</sup>Department of Crop Production, Federal University of Technology, Minna, Niger State, Nigeria

<sup>2</sup>Institute for Agricultural Research, Ahmadu Bello University, Samaru, Zaria,

Kaduna State

\*Corresponding Author's E-mail: [r.oyewale@futminna.edu.ng](mailto:r.oyewale@futminna.edu.ng), GSM:08069532552

### ABSTRACT

Maize is one of the cereal crops cultivated for food, feed and as industrial raw materials. Stem borers have been the most damaging group of insect pests in maize cultivation worldwide. Feeding by borer larvae on maize plants usually results in crop losses as a consequence of death of the growing point (dead heart), early leaf senescence, reduced translocation, lodging and direct damage to the ears. To ascertain this, a survey of maize stem borers was conducted in selected Local Government Areas (LGAs) of Niger state (Bida, Bosso, Chanchaga, Gbako, Paikoro, Wushishi) from June to August 2017. Three farms were surveyed in each LGAs for stem borer larvae, the larvae obtained were caged differently based on LGAs and reared to adults, then taken to Insect Museum at Department of Crop protection, Ahmadu Bello University, Zaria, Kaduna State for identification. The results showed that species of *Sesamiacalamistis* were found to be prevalent in the maize fields in the six LGAs of Niger state. Also result of Analysis revealed that Gbako local government area had the highest incidence and severity of maize borer infestation.

Key words: Survey, stem borers, larvae, species, maize

### INTRODUCTION

Maize (*Zea mays* L.) is a cereal crop in the family Poaceae. It is perhaps the most completely domesticated of all cereals (Okwechee *et al.*, 2012) and essentially a crop of warm countries with adequate soil moisture (Okwechee *et al.*, 2012). It originated from South America where it was taken to all parts of the world (Gonzalez, 2001). Modern maize is considered to have evolved from Teosinte (God's corn) than from early Mesoamerican maize called Chapalote or a *Tripacum* species (Brenneman, 2001). Maize is an important cereal crop with high economic value after wheat and rice in the world including Pakistan (Bukhshet *et al.* 2012). It has short growing season and is drought resistant that make it very easy to grow everywhere in different climatic conditions of the world (Amin 2011). Due to its highest yield potential among the cereals it is known globally as queen of cereals. The largest producer of maize is United States of America (USA) contributing about 35% of the total world maize production. It is known as mother grain of Americans and it is the driver of the US economy. In USA, EU, Canada and other developed countries, maize is used mainly to feed animals directly or sold to feed industry and as raw material for extractive fermentation industries. In Latin America and Africa

the main use of maize is for food while in Asia it is used for food and animal feed. In fact in many countries it is the basic staple food and an important ingredient in the diets of people. Globally, it has been estimated that approximately 21% of the total grain produced is consumed as food. Maize is the third most important food grain in India after wheat and rice. In India, about 28% of maize produced is used for food purpose, about 11% as livestock feed, 48% as poultry feed, 12% in wet milling industry (for example starch and oil production) and 1% as seed (AICRP on Maize, 2007).

The major species of stem borers associated with maize in Nigeria are the maize stalk borer, *Busseolafusca* Fuller (Noctuidae), the pink stalk borer, *Sesamiacalamistis* Hampson (Noctuidae), the millet stem borer, *Acigona ignefusalis* Hampson (Pyralidae) and the Africa sugarcane borer, *Eldanasaccharina* Walker (Pyralidae) (Balogun and Tanimola, 2001). Others of less importance are the spotted stalk borer (*Chilopartellus* Swinehoe. Pyralidae), *C. orichalcociliella*, *C. suppressalis*, and the ear borer (*Mussidianigrivenella* Pyralidae) (Khan, *et al.*, 2001). *Busseolafusca* larvae feed on the aboveground parts of the grass hosts, causing economically important yield losses to crops such as



maize. Feeding and tunnelling by *B. fusca* larvae can result in the destruction of the growing point (resulting in “deadhearts”), early leaf senescence, interference with nutrient and metabolite translocation resulting in malformation of the grain, stem break-age, plant stunting, and direct damage to ears (Kfirit *et al.*, 2002).

The severity and nature of stem borer damage depend upon the borer species, the number of larvae feeding on the plants and the plant reaction to the borer feeding. The occurrence of maize stem borers affect the crop throughout the growth stages from seedling to maturity. The objective of research work was to determine the occurrence and distribution of stem borers and identification of various borers in the survey fields. The information thereby obtained would be useful for developing resistant maize varieties, and information on the distribution pattern of different stem borers species in the study area.

## MATERIALS AND METHODS

### Study Sites and Sampling Technique

Six (6) local government areas were selected for the study in Niger state, namely; Bida, Bosso, Chanchaga, Gbako, Paikoro and Wushishi. Niger state is in the Southern Guinea Savanna of Nigeria, with Geographical Positioning System (GPS) co-ordinates of (Latitude 9.52335N, and Longitude 6.44791E).

Field survey was conducted in 6 selected maize growing local government areas (LGAs) of Niger state, Nigeria. In each local government, 3 farm sites were surveyed in 2017 cropping season. Maize stem borer severity was determined by visual observation of holes on the maize plants, based on 9- point rating scale (Appendix 1). The infested plants were selected randomly and the lepidopterans in their larval stage (stem borers) inside the infested plants were collected.

### Rearing of Larvae

Wooden insect cages were made, measuring 25 by 50cm in diameter and 50cm of height. The cages were cleaned thoroughly and small quantity of moist top soil was evenly distributed in the cages, before the insects larvae were introduced into the cages. The collected insects from surveyed farm sites were put inside their designated cages for each LGAs. Fresh maize leaves were put into their respective cages to feed on and then reared to adults.

### Identification and Classification Techniques

The insects at their adult stage were taken out of their respective cages and were kept in different transparent plastic containers and labeled (for the different farms at which they were collected). The samples were taken to the insect laboratory (Insect Museum) of the Department of Crop Protection, Faculty of Agriculture Ahmadu Bello University

(ABU), Zaria, Kaduna state for identification and classification by comparing with various existing species in the Insect Museum.

### Data Analysis

The average infested plants, in each farm from various LGAs were converted into percent infestation. The data were subjected to Analysis of variance (ANOVA) using Minitab package. Significant levels of the ANOVA were tested at 5% probability level and where significant, means were separated using least significant difference (LSD).

## RESULTS AND DISCUSSION

### Incidence of stem borer infestation in selected local government area of Niger State

The results indicated that there were significant ( $p \leq 0.05$ ) differences among the six local government areas surveyed in terms of incidence of stem borers infestation (Figure 1), Gbako LGA had the highest incidence (58.33) of stem borers which was significantly different from Wushishi (12.00), Bosso (13.33) and Paikoro (20.00), while Wushishi had the least incidence of stem borers but not significantly different from Bosso LGA.

### Severity of stem borer infestation in selected local government area of Niger State

The severity of maize stem borers in six LGAs of Niger State were significant. Gbako LGAs had the highest severity (33.33) which was significantly different from that observed in Wushishi LGA which had the lowest severity (7.00). The stem borer severity among other LGAs were not significantly.

Information from various farmers met on the farms during survey about the knowledge of the occurrence of stem borers was positive. They were aware of the presence and infestation of the pest, but no management strategy was attempted against it. The cropping system practiced by most farmers in the areas also making favourite breeding environment for the survival and infestation of stem borers because most farmers intercropped maize with sorghum, millet and pearl millet which serve as alternative host for some of stem borer species.

In this study, *S. calamistis* was the most predominant stem/stalk borer species. This agreed with the finding of Obhiokhenanet *et al.* (2001) who reported higher percentage of *S. calamistis* in the mangrove and rain forest zones of Nigeria. Polaszek (1998) had earlier reported that *B. fusca*, *S. calamistis*, *C. partellus*, *E. saccharina* and *C. ignefusalis* were the most important and widely distributed lepidopterous stem borers in Nigeria. Similar observations have been made in studies carried out in South-western Nigeria by Balogun and Tanimola, 2001 who reported that the

major species of stem borers associated with maize in Nigeria are the maize stalk borer, *Busseolafusca* Fuller (Noctuidae), the pink stalk borer, *Sesamiacalamistis* Hampson (Noctuidae), the millet stem borer, *Acigona ignefusalis* Hampson (Pyralidae) and the Africa sugarcane borer, *Eldanasaccharina* Walker (Pyralidae). Ogunwolu (1987) further reported that the difference in population between the two borer species was due to the feeding habit of the borers.

#### CONCLUSION AND RECOMMENDATION

The result of this study has shown that all the six LGAs surveyed for maize stem borers were positive but varied in terms of incidence and severity from one LGA to the other during the 2017 cropping season. Conventional identification carried out in the insect museum showed that *S. calamistis* was the most predominant stem/stalk borer species. The low yield

of maize has been attributed to the infestation of various species of stem borers in Nigeria. Furthermore, the study will assist the maize growing farmers in Niger State to take precautionary measure against the occurrence of stem borers in their localities.

Farmers should be enlightened on maize stem borer management to prevent the borer damage on their field. Improved resistance maize cultivars should be made readily available at subsidized rate for them. Further study should be conducted to ascertain the occurrence of stem borers annually.

**Table1.** States and Local Government Areas where Farms were surveyed

Local Govt Area	Location	Longitude ( <sup>0</sup> E)	Latitude ( <sup>0</sup> N)	Altitude (masl)
Bida	Bida	6.03996	9.11072	111
Bida	Bida	6.13219	9.21608	121
Bida	Bida	6.18545	9.27320	89
Paikoro	Seriki-fulani	6.61370	9.43995	300
Paikoro	Mabe	6.75539	9.40057	378
Paikoro	Jita	6.59153	9.36360	277
Wushishi	Kikamaria	6.15421	9.79919	137
Wushishi	Kaluko	6.161	9.822	138
Wushishi	Kompani	6.43889	9.81108	122
Bosso	Garatu	6.44689	9.53126	207
Bosso	Gidankwano	6.43889	9.48563	206
Bosso	Futminna farm	6.44689	9.51707	213
Gbako	Lemu	6.02759	9.40102	167
Gbako	Kunkele	6.03308	9.31362	138
Gbako	Ndakama	6.02189	9.15765	148
Chanchaga	Mandella	6.50680	9.58266	220
Chanchaga	Bebeji	6.5127	9.59210	217
Chanchaga	Chanchaga	6.53046	9.59737	226

( masl= metres above sea level)

**Table2.** Infestation of maize plant by stem borers.

Local Govt Area	Location	Hectares (m <sup>2</sup> )	Severity (%)	Incidence (%)
Bida	Bida	3	3	7
Bida	Bida	3	20	35

Bida	Bida	6	20	50
Paikoro	Seriki	2	30	20
Paikoro	Mabe	2	20	20
Paikoro	Jita	2	20	20
Wushishi	Kiria	1	10	20
Wushishi	Kaluko	1	10	15
Wushishi	Kompani	2	1	1
Bosso	Garatu	2	10	20
Bosso	GidanKwano	1	10	30
Bosso	Futminnafarm	3	35	40
Gbako	Lemu	2	70	30
Gbako	Maikunkele	1	55	4
Gbako	Ndakama	2	50	30
Chanchaga	Mandella	1	20	30
Chanchaga	Bebeji	1	50	35
Chanchaga	Chanchaga	1	10	15

**Table 3. Severity of Maize Stem Borer in selected government of Niger state**

Local Governments	Means
Bida	30.00 <sup>a</sup>
Paikoro	14.33 <sup>ab</sup>
Wushishi	7.00 <sup>b</sup>
Gbako	33.33 <sup>a</sup>
Bosso	30.00 <sup>a</sup>
Chanchaga	26.67 <sup>a</sup>

Means with the same letter in the same column are not significantly different by LSD at 0.05 probability level.

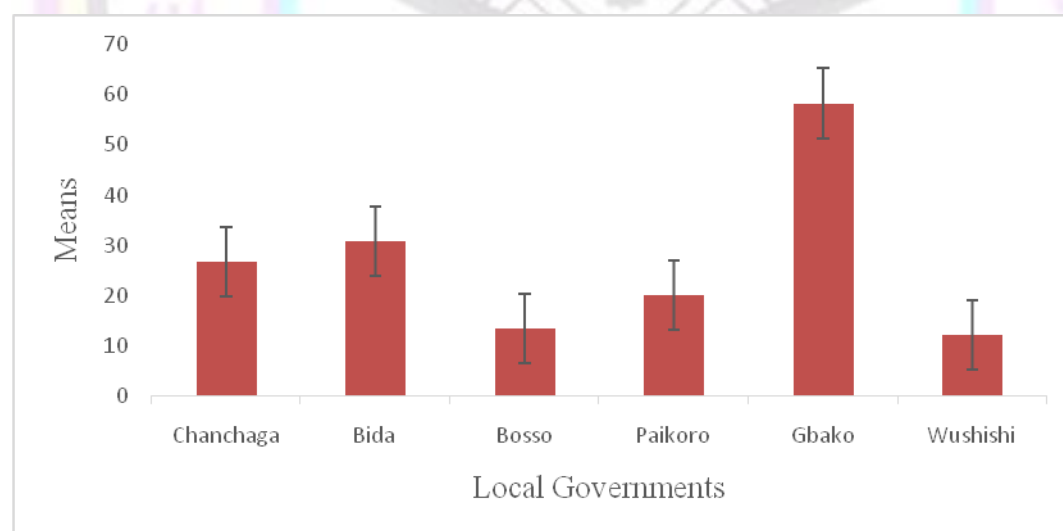


Figure 1: Incidence of Maize Stem Borer in Selected Local Government Area of Niger State

Appendix 1: Visual scoring scale used for assessing stem borer damage on maize plants

Visual rating of plant damage	Numerical score	Resistance reaction
Damage	0	Likely escape
Few pin holes	1	Highly resistant
Few short holes on few leaves	2	Resistant
Several short holes (<50%)	3	Resistant
Several leaves with short holes (>50%)	4	Moderately resistant
Elongated lesion on a few leaves	5	Moderately resistant
Elongated lesions on several leaves	6	Susceptible
Several leaves with long lesions or tattering	7	Susceptible



Severe tattering	8	Highly susceptible
Plant dying as a result of foliar damage	9	Extremely sensitive to damage

Source: CIMMYT, 1989

## REFERENCES

- Amin, M. E. M. H. (2011). Effect of different nitrogen sources on growth, yield and quality of foddermaize (*Zea mays* L.). *Journal of the Saudi Society of Agricultural Sciences* 10(1): 17–23.
- Balogun, O. S & Tanimola, O. S. (2001). Preliminary studies on the occurrence of stem borer and incidence of stalk rot under varying plant population densities in maize. *Journal of Agricultural Research and Development* 1: 67-73
- Brenneman, D. S. (2001). The verdict is in: corn is the direct descendant of Teosinte. *Southwestern Mission Research Centre Newsletter* 35:52
- Bukhsh M A A H A, Ahmad R, Ali A, Ishaque M and Rehman A. 2012. Potassium use efficiency of maize hybrids. *Journal of Animal and Plant Sciences* 22(3): 728–32.
- Gonzalez, R. F. (2001). Zapotec Science: Farming and Food in the Northern Sierra Oaxaca. University of Texas Press, Austin, U.S.A.
- Kfir, R., Overholt, W.A., Khan, Z.R., and Polaszek, A. (2002). Biology and management of economically important lepidopteran cereal stem borers in Africa. *Annual review of Entomology* 47: 701-731. Doi:10.1146/annurev.ento.47.091201.145254.[PubMed] [Cross Ref]
- Khan, Z. R. Pickett, J. A., Wadhams L. J. & Muyekho, F. (2001). Habitat management strategies for the control of cereal stem borers and *Striga* in maize in Kenya. *Insect Science Applied*, 21:275-380
- Milind, P., & Isha, D. (2013). Zea maize: A modern craze. *International Research Journal of Pharmacy*, 4, 39–43.
- Obhiokhenan, A. A.; Usua E J. & Umoetok S. B.A (2002). Distribution of Lepidopterous stem borers of maize (*Zea mays* L.) in ecological zones of Cross River State of Nigeria. *Global Journal of Agricultural Science*. 1:89-92.
- Ogunwolu, E. O. (1987). Efficacy of carbofuran against lepidopterous stem borer of maize. *Nigerian Journal of Agronomy* 2(2):27-32.
- Okweche, Simon Idoko and Umoetok, Sylvia B.A (2014). The distribution of maize stem borers in cross river state, Nigeria. Department of crop science, faculty of Agriculture, Forestry and Wildlife, P.M.B. 1115, University of Calabar, Nigeria. (623).
- Polaszek, A. (1998). Africa cereal stem borers. Economic Importance, Taxonomy, Natural Enemies and Control. CAB International. Wallingford. understanding of Biosafety Latest scientific findings, policy responses and public participation. South Africa: North-West University; (2010).

## UTILIZATION OF POST HARVEST TECHNOLOGIES AMONG YAM FARMERS IN SELECTED LOCAL GOVERNMENT AREAS OF NIGER STATE, NIGERIA

Hassan<sup>1</sup>\*, S., Salihu<sup>2</sup>, I. T., Abdullahi<sup>2</sup>, A., and Aliyu<sup>1</sup>, A.

<sup>1</sup>Department of Agricultural Economics and Extension Technology,  
Federal University of Technology, Minna, P.M.B. 65, Niger State, Nigeria

<sup>2</sup>Department of Agricultural Extension and Rural Development  
Federal University of Technology, Minna, P.M.B. 65, Niger State, Nigeria

\*Corresponding Author's E-mail: [organotim31@gmail.com](mailto:organotim31@gmail.com), GSM: [07061683781](tel:07061683781)

### ABSTRACT

*Yam is an important tuber crop in Nigeria. However, its availability is affected by rate of deterioration arising from poor postharvest handling. Hence, farmers use various techniques to minimize the loss. Therefore, this study examined the utilization of post harvest technologies among yam farmers in selected local Government areas of Niger state, Nigeria. Data were collected from 195 respondents and analyzed with descriptive statistics. The result revealed that, the mean age of the respondent was 35.0 years and highly experienced in food crops production with mean of 18.0 years experience. Majority of the respondents (79%) had formal education. However data analysis reveals that yam barn storage technique ranked first in terms of types and level of utilization by the farmers with the highest weighted mean (WM=3.87) while, open sided shelve was the least (WM=1.43). It is therefore recommended that extension agents should actively disseminate information on improved storage techniques to yam farmers in the study area as well as the need to use such techniques.*

**KEYWORDS:** Technology, Storage technique, Postharvest losses, Yam barn, Utilization.

### INTRODUCTION

Agriculture is the most important economic sector of any Nation saddled with the responsibility of meeting the food requirements of the rather fast growing global population (Andersen, 2010). The situation is dire with the projected world population expected to reach 10.5 billion by the year 2050 as stated by the United Nation (UN, 2013) thereby, adding to the global food security concerns. This projection, translates into 33% more human mouths to feed, with the greatest demand growth in the poor communities of the world. Food supplies would therefore need to increase by 60% as estimated at 2005 food production levels in order to meet the food demand in 2050 (Alexandratos and Bruinsma, 2012). To this end, food availability and accessibility can be increased by increasing production, improving distribution and reducing the losses by Food Agricultural Organization (FAO, 2010). Thus, reduction of post-harvest food losses is a critical component of ensuring future global food security.

Post harvest handling and storage of yam is an important aspect of economic development in Nigeria. Accurate financial worth of yam industry in Nigeria is hard to come by, but it was estimated at two hundred billion naira (200bl) per annum with estimated losses from storage over half the expected revenue (FAO, 2010). These losses were mostly attributed to rot caused by bacteria, fungi and

nematode. The bulk of these pathogens causing yam tuber rots are soil borne but manifestation of the tuber disease are observable mostly during storage (Okigbo, 2004).

Similarly, weight loss during storage in traditional or clamp storage can reach 10-12% in the first three months and 30-60% after 6 months of storage and in West Africa alone; this amounted to an annual loss of one million tons of tuber (FAO, 2003). It is important to also point out that maximization of profit can only be achieved when farmers are well equipped with required technological knowledge and skills of yam storage. This act is necessary because one of the major constraints upon establishing effective storage and processing management approaches for smallholder farmers is the lack of adequate information sources to increase farmers' knowledge level in the practices of yam tuber processing and storage. In fact, the need to understand farmers' knowledge systems has been recognized as a basis for development of proper storage and processing technologies that are sustainable and adaptable to local farmer's environmental condition.

However, despite the necessity of producing more food to meet the ever-increasing global population, most of agricultural produce are lost during post-harvest handling and that up to 50-70% losses are estimated between production area and consumption



point because of lack of storage facilities, limited access to processing technologies, unstable market prices, poor market opportunities and non utilization of postharvest technologies (Olayemiet *et al.*, 2012) and (Owolade, 2011). Post-harvest losses will lead to reduction in farmer's income, food insecurity, poor nutritional value and lack of input for the next production (Olayemiet *et al.*, 2012).

In recent times research on post harvest preservation has been given little support by both the government and the private sectors. To minimize post-harvest losses, improved methods of storage have therefore been developed. However, the poor economic status of most Nigerian farmers has inhibited the adoption and usage of most agricultural technologies (Alimi and Zango, 2016). It was hoped that farmers' usage of these technologies would lead to reduction in food losses, improved income and enhanced food security (Okoedo and Onemolease, 2009). Nevertheless, the widespread and continued use of traditional storage practices by small-scale farmers despite considerable losses usually associated with these methods need investigation.

Over the past decades, significant focus by researchers (such as: Gbemisola, 2009; shehu, 2010) and resources have been allocated to increasing food production. For instance, 95% of the research investments during the past 30 years were reported to have focused on increasing productivity, and only about 5% was directed towards reducing losses (Kader, 2005; Kader and Roller, 2004). Although, increasing agricultural productivity is critical for ensuring global food security but this may not be sufficient. The global food supply is currently being challenged by limited post-harvest preservation techniques as a result of a wide gap that exist between actual achievement and achievable potential in the yam farming industry. This study seeks to fill the identified research gap. In view of the above, this study is initiated to assess the utilization of post harvest technologies among yam farmers in selected areas of Niger state, Nigeria. The specific objectives are to:

- i. describe the socio economic characteristics of yam farmers
- ii. identify the types of post harvest technologies used by the yam farmers
- iii. examine the level of utilization of post harvest technologies by yam farmers
- iv. identify the constraints limiting the utilization of post harvest technologies by yam farmers in the study area.

## METHODOLOGY

The study was conducted in Niger State of Nigeria. Niger State is located between latitudes 8°11'2" N and 11° 20' 2" N and longitude 4° 30' 2" E and 7° 20' 2" E (Ojoet *et al.*, 2013). The State is located in the North central zone along the Middle Belt region of Nigeria. The state has a population of about 3,954,772 individuals as stated by the National Population Commission (NPC, 2006). Niger state is classified as one of the largest states in the country spanning over 86,000km<sup>2</sup> in land area with 80% of the land mass conducive for agriculture (Tologbonse, 2008). With 9.30% of the total land area of the country, Niger state is not only divided into three agricultural zones under climatic features containing nearly all classes of soils of the savannah regions of West Africa (Tologbonse, 2008). In order to achieve the study objectives, multiple sampling techniques were employed. This involves purposive selection of zone B of Niger state because of the preponderance of yam production in this zone. The second stage involved the purposive selection of three Local Government Areas known for higher yam production in the zone namely; Paikoro, Shiroro, and Bosso Local Government Areas. The third stage involved the random selection of two districts from the selected Local Government Areas. The fourth stage involved the random selection of two villages from each of the selected Local Government Areas. The fifth stage involved a proportionate random selection of 5% from the registered yam farmers in each of the selected villages. Therefore, a total of 195 yam farmers were considered as the sample size for this study. Interview schedule was used to elicit data from the respondents. The responses were analyzed using frequency counts, percentages and mean score to describe the socio economic characteristics and the types of post harvest technologies used by yam farmers. However a 4-point Likert type of scale was employed for objective (iii) and scored as follows: Always Used (AU) = 4, Frequently Used (FU) = 3, Sometimes Used (SU) = 2, Never Used (NU) = 1. A mean score of 2.5 was obtained and the decision rule is that any mean ( $\bar{X}$ ) scores  $\geq 2.5$  indicate used, while scores  $< 2.5$  not used. Similarly a 3-point Likert type of scale was employed for objective (iv) and scored as follows: Very Serious (VS) = 3, Serious (S) = 2, and Not Serious (NS) = 1. The mean score was obtained and the decision rule is that any mean ( $\bar{X}$ ) scores  $\geq 2.0$ , indicate serious constraint while scores  $< 2.0$  indicate Not serious constraint.

## RESULTS AND DISCUSSION

### Socio economic characteristics of the respondents



The results in Table 4.1 showed that majority (92.4%) of the respondents were between the age of 21 and 50 years, while only 3.1% were less than 20 years and 4.6% above 50 years. The mean age of the respondents was 35 years. The implication of the mean age on utilization of post-harvest technologies is that the young farmers can take risk by utilizing new technologies than the older farmers. This supports the findings of Jabil and Abdu (2012) who stated that young farmers are willing to use new technologies than the older ones and they are not averse to risk. Similarly, (69.2%) of the farmers had been into yam production for over 20 years and all the respondents had an average farming experience of 18 years. This implies that the farmers are quite experienced in yam cultivation. This compares favorably with the findings of Falola *et al.*, (2017); Oluwatosin (2011) that indicated that the yam farmers had a significant level of expertise in yam production. Similarly, more than half (59.0%) of the respondents had a household size of about 3-6 members, while the mean of the household size was found to be five (5), implying a large household size. This is in agreement with Giroh *et al.* (2012) who reported that farmers with large household size tend to channel more of their income to food consumption expenditure rather than to save and invest in improved storage technique. The result further revealed that majority (79%) of the respondents had formal education. This implies that respondents are educated enough to know and understand the complexities involved in improved technology to adopt it. This assertion is in contrast to Tor *et al.* (2017); Onemolease (2005), who reported that a low educational background not exceeding primary education may impede acceptance of improved post harvest technologies, since education facilitates farmers' utilization of innovations.

#### **Types of post harvest technologies used by yam farmers**

Post harvest technologies are referred to as technologies commonly used for the purpose of storing and processing by the yam farmers in the study area. The comprehensive list of technologies was developed and farmers were asked to indicate the technologies they use. Tables 2 showed that majority of the respondents use the following post harvest technologies: Storage in barn (98.5%), Processing into pounded yam (97.4%), Processing into fried yam (96.9%) and Storage in mud hut (88.7%). While open sided shelf stores (32.3%) and ventilated pit (28.7%) are the least storage methods used. This result agrees with that of Akangbe *et al.* (2012) who stated that storage of yam tubers in barns was the major storage method utilized while ventilated pit and open sided

shelf stores were the least methods used by the respondents in the study area.

#### **Level of utilization of post harvest technologies by yam farmers**

Table 3 indicates that storage of yam tubers in barns was the major storage method used by the respondents in the study area (mean = 3.87). However, in terms of frequency of utilization, (91.3%) of the respondents always use yam barns, followed by processing into pounded yam (90.2%) with the mean of 3.85, then processing into fried yam (77.9) with (mean = 3.68). Storage in open sided shelf stores were the least used storage techniques with (mean = 1.43). This implies that majority of the respondents depend on manual or traditional technology to execute some vital processes. This result agrees with that of Falola *et al.* (2017); Okoedo and Onemolease (2009) who stated that storage of yam tubers in barns was the major storage method utilized by the respondents in the study area. It also tallies with the findings of Akangbe *et al.*, (2012) who reported open sided store was the least adopted method by farmers in the storage of yam in Asa Local Government Area of Kwara State.

Summarily, level of utilization of post harvest technologies in the study area as shown in table 4 revealed that utilization level is low (51.3%) . This result may be attributed to lack of access and effective information on these improved technologies. Thus, respondents rely on traditional methods for yam storage and processing.

#### **Constraints limiting the utilization of post harvest technologies by yam farmers**

Analysis on table 5 revealed some of the constraints limiting the utilization of post harvest technologies. The result showed that the incidence of pest and diseases and lack of improved technology ranked first and third. This may be because of the quality deterioration of yam as a result of poor storage strategy till the time of sales. Most farmers in the study area use traditional method of storing yam. This result collaborated with the findings of Abubakar and Nasiru (2017) who stated that the yam barn are locally made or constructed which give room to micro-organisms and rodent to destroy yam tubers stored. High cost of labour has been identified to limit effective use of the local storage methods especially the storage barn. This is corroborated by Nwaigwe *et al.*, (2015) who reported that the construction of barn requires a lot of work and effort and is more expensive than other local storage methods. This finding agrees with that of Olayem *et*

*al.*, (2011) who stated that bruising and spoilage, high cost of transportation, inadequate storage facilities and menace of theft are responsible for losses incurred by farmers and marketers. However the result seems to disagree with the research of Okoedo and Onemolease (2009) that did not recognize theft of tubers as a significant cause of postharvest losses in yam production.

#### **CONCLUSION AND RECOMMENDATIONS**

The study examined the utilization of post harvest technologies among yam farmers in selected local government areas of Niger state, Nigeria. Based on the findings of this study, it was concluded that respondents use local post harvest technologies and utilization of modern postharvest technologies is low despite the losses due to the use of traditional techniques. It is therefore recommended that extension agents should actively disseminate information on improved post harvest to yam farmers in the study area as well as the need to use such technologies. New yam postharvest technologies should be made available to the farmers in the study area at subsidized rates so as to encourage them to use such technologies.



**Table 1: Socio-economic characteristic of respondents**

Variable	Frequency	Percentage	Mean
<b>Age</b>			
below 21 years	6	3.1	35
21-30 years	68	34.9	
31-40 years	53	27.2	
41-50 years	59	30.3	
51-60 years	9	4.6	
<b>Farming experience</b>			
below 11 years	46	23.6	18
11-20 years	89	45.6	
21-30 years	42	21.5	
31-40 years	15	7.7	
41-50 years	3	1.5	
<b>Household size</b>			
below 3 members	41	21.0	5
3-6 members	115	59.0	
above 6 members	39	20.0	
<b>Level of education</b>			
non formal	41	21.0	
Primary	43	22.1	
Secondary	58	29.7	
Tertiary	51	26.2	
Masters	2	1.0	

Source: ICAAT, 2018

**Table 2 Types of post harvest technologies used by yam farmers**

Technologies	Frequency	Percentage (%)
Storage in barn	192	98.5
Storage in pit	115	59.0
Curing method	82	42.1
Storage in mud hut	173	88.7
Storage in open sided shelf stores	63	32.3
Storage in elevated store shed	70	35.9



Storage in ventilated pit	56	28.7
Storage in thatched roof pit	74	37.9
Processing into flour	181	92.8
Processing into chips	123	63.1
Processing into fried yam	189	96.9
Processing into pounded yam	190	97.4

Source: ICAAT, 2018

**Table 3 level of utilization of post harvest technologies by yam farmers**

Technologies	AU	FU	SU	NU	WM	Rank
Storage in barn	178(91.3)	12(6.2)	2(1.0)	3(1.5)	3.87	1 <sup>st</sup>
Processing into pounded yam	176(90.2)	13(6.7)	1(0.5)	5(2.6)	3.85	2 <sup>nd</sup>
Processing into fried yam	152(77.9)	30(15.4)	7(3.6)	6(3.1)	3.68	3 <sup>rd</sup>
Processing into flour	130(66.7)	44(22.6)	7(3.6)	14(7.2)	3.49	4 <sup>th</sup>
Storage in mud hut	110(56.4)	49(25.1)	14(7.2)	22(11.3)	3.27	5 <sup>th</sup>
Processing into chips	19(9.7)	30(15.4)	74(37.9)	72(36.9)	1.96	6 <sup>th</sup>
Storage in pit	13(6.7)	36(18.5)	66(33.8)	80(41.0)	1.91	7 <sup>th</sup>
Storage in thatched roof pit	17(8.7)	19(9.7)	38(19.5)	121(62.1)	1.66	8 <sup>th</sup>
Curing method	6(3.1)	15(7.7)	61(31.3)	113(57.9)	1.56	9 <sup>th</sup>
Storage in elevated store shed	5(2.6)	10(5.1)	55(28.2)	125(64.1)	1.46	10 <sup>th</sup>
Storage in ventilated pit	4(2.1)	23(11.8)	29(14.9)	139(71.3)	1.45	11 <sup>th</sup>
Storage in open sided shelf stores	5(2.6)	10(5.1)	48(24.6)	132(67.7)	1.43	12 <sup>th</sup>

Source: ICAAT, 2018

**Note:** Always Used (AU); Frequently Used (FU); Sometimes Used (SU); Never Used (NU) WM=Weighted Mean

**Table 4 categorization of respondents' level of utilization of post harvest technologies**

Utilization level	Frequency	Percentage
Low utilization (0 - 0.33)	100	51.3
Moderate utilization (0.34 - 0.66)	63	32.3
High utilization (0.67 - 1.00)	32	16.4
<b>Total</b>	195	100.0

Source: ICAAT, 2018

**Table 5 constraint faced by yam farmers**

Constraints	VS	S	NS	WM	Rank
Pests and diseases	161(82.6)	30(15.4)	4(2.1)	2.81	1 <sup>st</sup>
Poor transport network	146(74.9)	49(25.1)	0(0)	2.75	2 <sup>nd</sup>
Lack of improved technology	150(76.9)	33(16.9)	12(6.2)	2.71	3 <sup>rd</sup>
Long distance to market	140(71.8)	49(25.1)	6(3.1)	2.69	4 <sup>th</sup>
Insufficient working capital	141(72.3)	47(24.1)	7(3.6)	2.69	4 <sup>th</sup>
High cost of transportation	141(72.3)	41(21.0)	13(6.7)	2.66	6 <sup>th</sup>
Lack of credit	123(63.1)	53(27.2)	19(9.7)	2.58	7 <sup>th</sup>
High cost of labour	121(62.1)	66(33.8)	8(4.1)	2.58	7 <sup>th</sup>
Theft of yam	121(62.1)	65(33.3)	9(4.6)	2.57	9 <sup>th</sup>
Low government support	116(59.5)	58(29.7)	21(10.8)	2.49	10 <sup>th</sup>
Limited land	94(48.2)	67(34.4)	34(17.4)	2.31	11 <sup>th</sup>
Labor unavailability	83(42.6)	85(43.6)	27(13.8)	2.29	12 <sup>th</sup>
Injury on yam	64(32.8)	104(53.3)	27(13.8)	2.19	13 <sup>th</sup>
Poor storage facilities	60(30.8)	109(55.9)	26(13.3)	2.17	14 <sup>th</sup>
Illiteracy	65(33.3)	93(47.7)	37(19.0)	2.14	15 <sup>th</sup>
Lack of storage/ Processing facilities	65(33.3)	88(45.1)	42(21.5)	2.12	16 <sup>th</sup>
Poor management skill	68(34.9)	77(39.5)	50(25.6)	2.09	17 <sup>th</sup>
Poor buyers	50(25.6)	83(42.6)	62(31.8)	1.94	18 <sup>th</sup>
Over storage	40(20.5)	98(50.3)	57(29.2)	1.91	19 <sup>th</sup>
Lack of extension contact	59(30.3)	59(30.3)	77(39.5)	1.91	19 <sup>th</sup>

Source: ICAAT, 2018

**Note:** VS-Very Serious; S-Serious; NS-Not Serious; WM=Weighted Mean

## REFERENCES

- Abubakar, M. and Nasiru, M. I. (2017). Assessment of post-harvest losses of yam in selected district of Karu local government area, Nasarawa state. *FUW Trends in Science & Technology Journal*, retrieved from [www.ftstjournal.com](http://www.ftstjournal.com)
- Akangbe, J.A., Oloruntoba, O. O., Ayanda, I.F. and Komolafe, S. E. (2012). An Analysis of Yam Storage Strategy to Promote Food Security. *Ethiopian Journal of Environmental Studies and Management* 5 (4): 550-558
- Akinbile, L. A. (2007). Standardization of socio-economic status (SES) scale for farm family in south-west Nigeria. *Journal of social sciences*, 14(3): 221-227.
- Alexandratos, N. and J. Bruinsma. (2012). World agriculture towards 2030/2050: the saving water. From Field to Fork-Curbing Losses and Wastage in the Food Chain 2012 revision. Working paper: FAO: ESA No. 12-03, p.4.
- Alimi, H. M. and Zango, M. I. (2016) The Influence of Socio-Economic Variables On Adoption Behaviour Towards Tadco Improved Rice Parboiling Technique Among Rice Parboilers In Kura Processing Areas Of Kano State, Nigeria. *Agrosearch*. 16 (2): 51-60
- Andersen, P., (2010). The State of Food Security in Pakistan: Future Challenges and Coping Strategies, 903–923.
- Falola, A., Salami, M. F., Bello, A. A. and Olaoye T. A. (2017). Effect of yam storage techniques usage on farm income in kwara state, Nigeria. *Agrosearch (2017)* 17(1): 54– 65.
- FAO. (2003), Food and Agricultural Organization 2003. Data bases. F.A.O. report (1998).
- Food and Agricultural Organization. (2010). Nigeria Food Security report 2010. Food Security Statistics, Nigeria (FAOSTAT) [www.fao.org](http://www.fao.org).
- Gbemisola, O. and Paul, W. (2009). Rural nonfarm activities and agricultural crop production in Nigeria. *Wiley Blackwell journal*, 40(2): 189-201
- Giroh, D. Y., Gal, T. N. and Minampah, C. J. (2012). Analysis of the Determinants of Savings among Gum Arabic Collectors in Selected Local Government Areas of Adamawa State, Nigeria. *New York Science Journal*, 5(11): 1-6
- Jabil, I. Y and Abdu, U. D. (2012). Socio-economic characteristics of farmers and the factors that hampers their Adoption of Agricultural Technologies in Northern Central Zones of Plateau State, Nigeria. *International journal of agriculture economics and extension*, 4 (1): 5.
- Kader, A. A. (2005). “Increasing food availability by reducing postharvest losses of fresh produce.” *Acta Horticulture* 68(2): 2169-2176.
- Kader, A. A. and R. S. Rolle. 2004. The Role of Post-harvest Management in Assuring the Quality and Safety Horticultural Crops. Food and Agriculture Organization. *Agricultural Services Bulletin* 15(2): 52 .
- National Population Commission, NPC (2006). Nigeria Population Census Report, NPC Abuja.
- Nwaigwe, K. N., Okafor, V. C., Asonye, G. U. and Nwokocha, J. C. (2015). *Analysis of Tuber Storage Techniques in Africa: A Review*. ASABE Annual International Meeting, July 26-29, New Orleans, Louisiana.
- Ojo, M. A., Nmadu, J. N., Tanko, L. and Olaleye, R. S. (2013). Multinomial Logit Analysis of Factors Affecting the Choice of Enterprise among Small-holder Yam and Cassava Farmers in Niger State, Nigeria. *journal of agricultural science*, 4(1): 7-12
- Okigbo, R. N. (2004). A review of biological control methods for postharvest yams *Dioscoreaspp*. In storage in South Eastern Nigeria. *King Mongkut's institute of technology Ladkrabangscience journal*. 4(1): 207 - 215.
- Okoedo-Okojjie, D. U. and Onemolease, E. A. (2009). Factors Affecting the Adoption of Yam Storage Technologies in the Northern Ecological Zone of Edo State, Nigeria. *Journal of Human Ecology*. 27(2): 155-160.



- Olayemi, F. F., Adegbola, J. A., Bamishaiye, E. I. and Awagu, E. F. (2011) Assessment of postharvest losses of some selected crops in eight local government areas of Rivers state Nigeria, *Asian Journal of Rural Development*, 20(11): 1-11.
- Oluwatosin F. M. (2011): Measuring Technical Efficiency of Yam Farmers in Nigeria: A Stochastic Parametric Approach. *Agricultural Journal*6 (2): 40-46.
- Onemolease, E. A (2005). Impact of the Agricultural Development Programme (ADP) Activities in Arable Crop Production on Rural Poverty Alleviation in Edo State, Nigeria. Ph.D Thesis (Unpublished). University of Benin, Benin City, Edo State, Nigeria pp123
- Owolade, S. O. (2011). Promotion of food Security through reduction in post-harvest losses of horticulture crops in Nigeria. *Journal of Horticulture*. 1 (9): 14-16.
- Shehu, J. F., Iyortyer, I. T., Mshelia, S. I. and Jongur, A. A. U. (2010). Determinants of yam production and technical efficiency among yam farmers in Benue State Nigeria. *Journal of SocialScience*, 24(2): 143-148.
- Tologbonse, D. (2008). Policy Issues In Meeting Rice Farmers Agricultural Information Needs in Niger State. *Journal of Agricultural Extension*. 12(2): 84-94.
- Tor, I. E., Iheanacho, A. C. and Okeke, A. M. (2017). Analysis of Socio – economic Challenges of Using Local Storage Systems for Root and Tuber Crops in Benue State, Nigeria. *International Journal of Innovative Agriculture & Biology Research* 5(4): 30-37.



# EFFECT OF TILLAGE AND WEED CONTROL METHODS ON THE GROWTH AND YIELD OF MAIZE (*Zea mays* L)

Adesina, O. A.<sup>1\*</sup> A.P. Ajakpovi<sup>2</sup>. H.A Ibrahim<sup>3</sup>

<sup>1</sup>Crop Production Department, Federal University of Technology Minna.

<sup>2</sup>Department of Agricultural Economics and Extension Services, Federal University Oye- Ekiti.

<sup>3</sup>Crop Production Department, Federal University of Technology Minna

\*Corresponding Author's Email: [adolwak@gmail.com](mailto:adolwak@gmail.com) GSM: 07033160767

## ABSTRACT

A field experiment was conducted during the 2007 raining season at the research farm of Institute of Agricultural Research and Training (IAR&T) Moor Plantation Ibadan to determine the effects of tillage and cultural weed control method on growth and yield of three maize varieties. The tillage methods evaluated are ploughed twice ( $T_1$ ), ploughed twice, harrowed once ( $T_2$ ), ploughed twice harrowed once and ridged ( $T_3$ ) and zero tillage ( $T_4$ ). The cultural weed control adopted was hoe weeding and the three maize varieties used are Suwan- ISR - Y (Suwan I Striga Resistance- Yellow) ( $V_1$ ), TZPBSR - W (Tropical *Zea mays* Population Borer and Streak Resistant - White) ( $V_2$ ) and DMR - LSR - Y (Downey Mildew Resistant, Late maturing Streak Resistant, Yellow) ( $V_3$ ). Results showed that  $T_1$  favours the highest response of all the three varieties for vegetative growth and yield under cultural weed control method. All the 3 varieties had high yield value under  $T_1$  (Suwan-ISR-Y = 4755.6Kg/ha, TZPBSR-W = 7555.6Kg/ha and DMR-LSR-Y = 4311.1Kg/ha). The highest yield (7555.6Kg/ha) was obtained with TZPBSR-W. All varieties had their least yield under  $T_4$ . The  $T_1$  was recommended for maize cultivation especially under cultural weed control method.

**KEYWORDS:** Cultural, growth, tillage, weed, yield.

## INTRODUCTION

Maize belongs to the family gramineae and is one of the most important food crop worldwide with a remarkable production potential (Jennifer and Gregory, 1997; Komolafe, 2007unpublished; Nuss and Tanumihardjo, 2010). The origin of maize has been a matter of controversy but the most common opinion is that maize originated through domestication of wild grass Teosinte (*Zea mexicana*) which is native to Mexico, Guatemala and Honduras. Maize is one of the crops that are produced in greater quantities than other crops (Jennifer and Gregory, 1997). In Africa, Nigeria in particular, maize is one of the crops used by many families to ameliorate poverty by using it to replace other costlier foods. Maize brings people and culture together and help them realise their dependence on one another (Iwuafor, 1986, unpublished; Nuss and Tanumihardjo, 2010).

According to Oguntoyinbo (1987), Maize performs best on well drained, aerated, warm, deep and soft loam having adequate organic matter content and rich in nutrient. Different tillage operations are usually carried out before maize is planted based on how much money the farmer is having to spend or the time available in the growing season for land preparation. Decisions on tillage practices by

farmers' are usually made not in relation to intended weed control method, be it chemical (herbicides) or cultural (hoe weeding) due to knowledge gap and lack of awareness by famers. Osunbitten *et al.*, (2005) indicated that soil bulk density decreases with the degree of soil manipulation during tillage practices with no tillage having the highest and ploughed harrowed having the least. They stated further that effects of the degree of soil manipulation on hydraulic conductivity, soil bulk density, soil strength and penetration consequently affects crop productivity (Kayode and Ademiluyi, 2004; Ressia *et al*, 2003). To this extent, Douglas (1995) stated that care must be taken in soil manipulation since tropical soils are physically fragile, generally low in fertility and easily eroded when cleared of natural vegetation.

Weeds on the other hand are unwanted plants that struggle for existence in competition with crops. Several researchers (Steiner and Twomlow, 2003; Lehoczky and Reinsinger, 2003) have reported a yields reduction of up to one tonne per hectare in maize as a result of weed invasion, and that to boost maize production, the effect of weeds should be reduced. Weeds can be controlled culturally and chemically among other methods (Parish, 1990).

The economic importance of maize necessitates the study of factors that will improve its growth and yield. Thus there is need to determine what the impact of these land preparation methods in combination with cultural weed control method will have on maize yield. Hence, the objective of this study was to determine the effect of different tillage practices and cultural weed control method on the growth and yield of maize.

## METHODOLOGY

### Experimental Site

The experiment was carried out at research farm of Institute of Agricultural Research and Training (IAR&T) Moor Plantation Ibadan.

### Treatment and experimental design

The treatment comprised of factorial combination of four tillage practices (ploughed twice-T<sub>1</sub>, ploughed twice and harrowed once- T<sub>2</sub>, ploughed twice and harrowed once and ridged T<sub>3</sub> and zero tillage-T<sub>4</sub>), one weed control method (Cultural weed control: hoe weeding) and three maize varieties (Suwan-ISR-Y, TZPB-SR-W and DMR-LSR-Y) arranged and laid out in a randomized complete block design and replicated three times. Plot size for each treatment was 6.5m by 6.5m.

### Planting and Crop Maintenance

Three varieties of maize were used as test crops. Three seeds were planted per hole and thinned to one plant per stand after two weeks. Hoe weeding was used as cultural weed control method. It was regularly done at three weeks interval and weeded three times before terminating the experiment.

### Data collection

Crops growth data which includes stem girth (cm), number of leave and plant heights (cm) were measured at four, six and eight weeks after planting (WAP). Crops yields data collected including kilogram weight per hectare for fresh weight and at 10 % moisture content.

### Data Analysis

The data collected were subjected to Analysis of Variance (ANOVA). Where there is significant difference among the treatments, the Duncan Multiple Range Test (DMRT) at 5% significant level was used for mean separation.

## RESULTS AND DISCUSSION

Table 1 shows the result of physical and chemical analysis carried out on soil sample obtained from the experimental site. The textural class of the soil used for the experiment is sandy-loamy. The pH is slightly acidic

This soil structure and texture is suitable for maize cultivation according to AIC, (2004) which states that maize is well adapted to a well-drained sandy loam to silt loam soils.

### The effects of tillage on growth parameters of maize varieties under cultural weed control method

Table 02 shows the mean value for stem girth of maize plants at 4, 6 and 8WAP under cultural weed control method. The highest stem girth size was obtained in DMR-ISR-Y under ploughed twice at 4WAP. TZPB-SR-W was significantly different ( $p \leq 0.05$ ) at 6WAP and 8WAP under ploughed twice. The least value was obtained in Suwan-ISR-Y under zero tillage at 6WAP and 8WAP.

In Table 03, the highest numbers leaf was obtained in TZPB-SR-W at 8WAP for ploughed twice followed by TZPB-SR-W and DMR-LSR-Y with same leaf numbers each in ploughed twice and harrowed once. The number of leaf was the same for ploughed twice, ploughed twice and harrowed once and ridged at 4WAP. The least number of leaves at 8WAP is consistent with ploughed twice and harrowed once, ploughed twice harrowed once and ridged and zero tillage.

The effects of tillage on growth parameters of maize varieties under cultural weed control method for plant height are shown in Table 04. The highest value was obtained in DMR-LSR-Y under ploughed twice and harrowed once at 4WAP and 6 WAP. DMR-LSR-Y had the highest value at 8WAP under ploughed twice. The least value was consistent under zero tillage at 4, 6, and 8 WAP. The difference in height was more significant in DMR-LSR-Y at 4WAP in ploughed twice harrowed once.

Poor responses was obtained under zero tillage in almost all the growth parameters under cultural weed control method and this is an indication for poor growth and yield. Also, the highest value gotten in ploughed twice in most of the growth parameters under cultural weed control method is a pointer to good conformation and high yield. This is because there was adequate room for photosynthesis, proper nutrient and water utilization and the ability of the plant to bear maize cob at a proper level above the ground without lodging, thereby preventing rodents, disease and insect attacks. This best performance



under ploughed twice also agrees with the recommendation of Agribusiness Information Centre, (2004) that “there is no need of excessive soil manipulation for maize production.”

#### **Effects of Tillage and Cultural weed control on the yield (kg/ha) of Maize Varieties (Fresh weight and at 10% Moisture Content)**

Table 06 showed the mean yield of three maize varieties for Fresh weight and at 10% moisture content (MC) under cultural weed control method. TZPB-SR-W had the highest yield for Fresh weight in ploughed twice while the least yield was gotten in DMSR-MSR-Y at 70 MC under zero tillage. It was also followed by TZPB-SR-W under ploughed twice harrowed once. At 10% MC Suwan-ISR-Y was significantly higher than the rest under T<sub>1</sub>, followed by TZPB-SR-W also under T<sub>1</sub>. DMR-LSR-Y had lowest yield in zero tillage under cultural control method for Fresh weight and 10% MC.

#### **CONCLUSION AND RECOMMENDATIONS**

With the result obtained from growth and yield performances of the three varieties of maize under different tillage and cultural weed control method, it can be concluded that ploughed twice is the best tillage method as it best favours growth and yield of maize. It is hereby recommended that ploughed twice should be used for maize cultivation especially under cultural weed control method.

#### **ACKNOWLEDGEMENTS**

My gratitude goes to my supervisor, Dr O.B Adetayo and Mr Wale Adetayo for their immense contribution towards the completion of this study.

Table 1. The soil physical and chemical properties of the site prior to planting.

Parameters	Values
Ph	5.79
Ca (cmol/kg)	0.86
Mg (cmol/kg)	0.72
K (cmol/kg)	0.13
Na (cmol/kg)	0.52
H <sup>+</sup>	0.12
Av. P (cmol/kg)	4.30
Zn (cmol/kg)	8.00
C.E.C (cmol/kg)	2.35
% Organic Carbon	0.68
% Organic Matter	1.17
% N	0.07
% Sand	76.8
% Silt	13.00
% Clay	10.02

Table 2: The Effects of Tillage and Cultural weed control on the Stem Girth (cm) of maize varieties

VxT	4WAP	6WAP	8WAP	
V <sub>1</sub> T <sub>1</sub>		2.73	5.23 <sup>b</sup>	4.57 <sup>b</sup>
V <sub>1</sub> T <sub>2</sub>		2.76	4.63 <sup>b</sup>	4.83 <sup>b</sup>
V <sub>1</sub> T <sub>3</sub>		2.46	4.20 <sup>b</sup>	4.73 <sup>b</sup>
V <sub>1</sub> T <sub>4</sub>		2.58	3.43 <sup>bc</sup>	4.13 <sup>b</sup>
V <sub>2</sub> T <sub>1</sub>		2.86	6.50 <sup>a</sup>	7.47 <sup>a</sup>
V <sub>2</sub> T <sub>2</sub>		2.43	5.23 <sup>b</sup>	5.86 <sup>b</sup>
V <sub>2</sub> T <sub>3</sub>		2.60	5.33 <sup>b</sup>	5.96 <sup>b</sup>
V <sub>2</sub> T <sub>4</sub>		2.70	4.20 <sup>b</sup>	4.17 <sup>b</sup>
V <sub>3</sub> T <sub>1</sub>		2.86	5.16 <sup>b</sup>	5.33 <sup>b</sup>
V <sub>3</sub> T <sub>2</sub>		3.20	4.70 <sup>b</sup>	5.03 <sup>b</sup>
V <sub>3</sub> T <sub>3</sub>		2.83	4.66 <sup>b</sup>	4.87 <sup>b</sup>
V <sub>3</sub> T <sub>4</sub>		2.70	4.76 <sup>b</sup>	4.23 <sup>b</sup>
CV%		13.77	15.68	15.65
S.E.M		0.38	0.76	0.80

Means with the same letter are not significantly different (at 5% level of significance) according to Duncan Multiple Range Test.

KEY: V<sub>1</sub>=Suwan-ISR-Y; V<sub>2</sub>= TZPB-SR-W; V<sub>3</sub>= DMR-LSR-Y.

T<sub>1</sub>= Ploughed Twice T<sub>2</sub>= Ploughed Twice, Harrowed Once T<sub>3</sub>= Ploughed Twice Harrowed Once and Ridged T<sub>4</sub>= Zero Tillage

WAP= Week After Planting



Table 3: Effects of Tillage and Cultural weed control on the Number of Leaves for Maize varieties

VxT	4WAP	6WAP	8WAP
V <sub>1</sub> T <sub>1</sub>	6 <sup>b</sup>	8	11
V <sub>1</sub> T <sub>2</sub>	6 <sup>b</sup>	9	9
V <sub>1</sub> T <sub>3</sub>	6 <sup>b</sup>	7	9
V <sub>1</sub> T <sub>4</sub>	6 <sup>b</sup>	7	10
V <sub>2</sub> T <sub>1</sub>	6 <sup>b</sup>	9	12
V <sub>2</sub> T <sub>2</sub>	7 <sup>a</sup>	8	12
V <sub>2</sub> T <sub>3</sub>	7 <sup>a</sup>	8	11
V <sub>2</sub> T <sub>4</sub>	6 <sup>b</sup>	8	9
V <sub>3</sub> T <sub>1</sub>	7 <sup>a</sup>	8	10
V <sub>3</sub> T <sub>2</sub>	6 <sup>b</sup>	8	11
V <sub>3</sub> T <sub>3</sub>	6 <sup>b</sup>	8	10
V <sub>3</sub> T <sub>4</sub>	6 <sup>b</sup>	8	9
CV (%)	10.33	17.96	10.96
S.E.M	0.66	1.43	1.06

Means with the same letter are not significantly different (at 5% level of significance) according to Duncan Multiple Range Test.

Table 4: Effects of Tillage and Cultural weed control on the Plant Height (cm) of maize varieties.

VxT	4WAP	6WAP	8WAP
V <sub>1</sub> T <sub>1</sub>	19.70 <sup>b</sup>	45.60 <sup>a</sup>	106.26
V <sub>1</sub> T <sub>2</sub>	16.36 <sup>b</sup>	43.30 <sup>a</sup>	88.76
V <sub>1</sub> T <sub>3</sub>	16.53 <sup>b</sup>	32.03 <sup>b</sup>	83.03
V <sub>1</sub> T <sub>4</sub>	16.20 <sup>b</sup>	28.33 <sup>b</sup>	68.77
V <sub>2</sub> T <sub>1</sub>	21.46 <sup>b</sup>	45.37 <sup>a</sup>	71.10
V <sub>2</sub> T <sub>2</sub>	16.40 <sup>b</sup>	42.56 <sup>a</sup>	100.03
V <sub>2</sub> T <sub>3</sub>	18.03 <sup>b</sup>	40.07 <sup>a</sup>	66.63
V <sub>2</sub> T <sub>4</sub>	17.87 <sup>b</sup>	31.03 <sup>b</sup>	51.86
V <sub>3</sub> T <sub>1</sub>	21.86 <sup>b</sup>	51.53 <sup>a</sup>	108.70
V <sub>3</sub> T <sub>2</sub>	30.46 <sup>a</sup>	52.10 <sup>a</sup>	104.33
V <sub>3</sub> T <sub>3</sub>	17.60 <sup>b</sup>	46.50 <sup>a</sup>	92.60
V <sub>3</sub> T <sub>4</sub>	22.17 <sup>b</sup>	42.20 <sup>a</sup>	84.63
CV%	31.25	17.75	30.65
S.E.M	6.11	7.40	26.22

Means with the same letter are not significantly different (at 5% level of significance) according to Duncan Multiple Range Test

Table 5: Effects of Tillage and Cultural weed control on the yield (kg/ha) of Maize Varieties (Fresh Weight and at 10% Moisture Content (MC)

VxT

V<sub>1</sub>T<sub>1</sub>  
V<sub>1</sub>T<sub>2</sub>  
V<sub>1</sub>T<sub>3</sub>  
V<sub>1</sub>T<sub>4</sub>  
V<sub>2</sub>T<sub>1</sub>  
V<sub>2</sub>T<sub>2</sub>  
V<sub>2</sub>T<sub>3</sub>  
V<sub>2</sub>T<sub>4</sub>  
V<sub>3</sub>T<sub>1</sub>  
V<sub>3</sub>T<sub>2</sub>  
V<sub>3</sub>T<sub>3</sub>  
V<sub>3</sub>T<sub>4</sub>  
CV%  
S.E.M





## REFERENCES

- Agribusiness Information Centre (2004). Production Guidelines for Maize. Agribusiness Information Centre. Federation of Indian Chamber of Commerce and Industry (FICC), 4<sup>th</sup> Floor Federation House Tansen Marg. New Delhi. , pp. 1-7
- Bolarinwa Senjobi, (2007). The effects of Tillage Practices on soil properties under a maize cultivation in South Western Nigeria . 2007. Olabisi Onabanjo University, Ogun state, Ayetoro, Nigeria.
- Douglas, C. Couper (1995). No Till farming in the humid and sub-humid, Tropics Africa. IITA Research Guide 3, 2<sup>nd</sup> Edition. Training programme IITA, Ibadan, Nigeria. Pg. 5-8
- Iwuafor, E.N.O, (1998). The effects of Tillage and crop residue management practices on soil properties and crop performance in the southern Guinea Savannah zone of Nigeria. Unpublished Ph,D Thesis Ahmadu Bello University Zaria. Pp 254-255
- Jennifer G kling and Gregory E, (1997). Morphology and Growth of Maize, IITA/CIMMYT Research Guide 9, 2<sup>nd</sup> Edition. P 36.
- Kayode J and Ademiluyi B (2004). Effect of Tillage Methods on Weed Control and Maize performance in Southwestern Nigeria. *Journal of Sustainable Agriculture*, (2004). Vol 23(No 3) pg. 39-45 [doi.org/10.1300/J064v23n03\\_05](https://doi.org/10.1300/J064v23n03_05)
- Komolafe R.F. (2007). Comparative effects of Organo-mineral Fertilizer and Poultry Dung on the growth of Maize. Unpublished student research work Federal College of Agriculture, Moor Plantation, Ibadan. Pg 1-8.
- Nuss, E. T., and Tanumihardjo, S. A. (2010). Maize: a paramount staple crop in the context of global nutrition. *Comprehensive reviews in food science and food safety*, 9(4), 417-436.
- Steiner, K.G. and Twomlow, S. (2003). Weed management in conservation tillage systems. *African Conservation Tillage Network. Information Series, 8* (Retrieved from [http://www.act-africa.org/file/newsletters/promotional\\_materials/bulletins/Weed%20Management%20in%20Conservation%20Tillage%20Systems.pdf](http://www.act-africa.org/file/newsletters/promotional_materials/bulletins/Weed%20Management%20in%20Conservation%20Tillage%20Systems.pdf))
- Lehoczky E, Reisinger P, (2003). Study on the Weed-Crop Competition for Nutrients in Maize. *Applied Biology Sciences* 2003. Georgiken Faculty of Agriculture Science Keszthely, Veszprein University H -8360 Keszthely, Deak F.U. 16, Hungary. Pg 378-80 (Retrieved from [https://www.researchgate.net/profile/Eva\\_Lehoczky/publication/8557341\\_Study\\_on\\_the\\_weed-crop\\_competition\\_for\\_nutrients\\_in\\_maize/links/58e634d4a6fdcc6800b44c30/Study-on-the-weed-crop-competition-for-nutrients-in-maize.pdf](https://www.researchgate.net/profile/Eva_Lehoczky/publication/8557341_Study_on_the_weed-crop_competition_for_nutrients_in_maize/links/58e634d4a6fdcc6800b44c30/Study-on-the-weed-crop-competition-for-nutrients-in-maize.pdf))
- Oguntoyinbo S.S, (1987). Climatic Variability and Food Crop Production in West Africa *Geo Journal* 5(2), Pg 139-149 (Retrieved from <https://link.springer.com/content/pdf/10.1007/BF02582047.pdf>)
- Osunbitan J.A, Oyedele D.J., Adelaku K.O. (2005). Tillage Effects on Bulk Density, Hydraulic Conductivity and Strength of a Loamy Sand Soil in Southwestern Nigeria. *Soil and Tillage Research*, Vol. 82 No. 1. Pg 57-64 [doi.org/10.1016/j.still.2004.05.007](https://doi.org/10.1016/j.still.2004.05.007)
- Parish S, (1990). A review of Non-Chemical Weed Control Techniques. The West Scotland College, Auchin Cruive, Ayr KA6 5HW, Scotland. Academia publishers Printed in Great Britain. Vol. 7 pp 117-137 [doi.org/10.1080/01448765.1990.975454](https://doi.org/10.1080/01448765.1990.975454)
- Ressia J. Mendivila, Balbuena R, Pablo M. de, (2003). Corn Hybrid Emergence under the Tillage Systems. *Agro-Ciencia*, 2003 (vol. 19) (No. 2) 115-119

## MAPPING OF PHYTOPLANKTON COMPOSITION AND ABUNDANCE IN TAGWAI DAM RESERVOIR NIGER STATE, NIGERIA

Ibrahim <sup>1\*</sup>, S. U., A. T. Yisa <sup>2</sup>, A. Ibrahim <sup>3</sup>, I. H. Abah <sup>4</sup>

<sup>1,2,3,4</sup>Department of Water Resource, Aquaculture and Fisheries Technology, FUT, Minna, Niger State, Nigeria

\*Corresponding Author's E-mail: [suibrahim@futminna.edu.ng](mailto:suibrahim@futminna.edu.ng) GSM: 07039025846

### ABSTRACT

The mapping of phytoplankton composition and abundance of Tagwai reservoir were assessed with the aid of computer-assisted interpretation of Quick Bird Satellite imagery (Geographical Information System) over a period of six months (February-July 2016). Four sampling stations were selected based on provincial activities around the lake and the co-ordinate points of each identified sampling station were taking using Global Positioning System (GIS). Plankton net was used to take plankton samples from the water surface monthly, preserved using with 5% formalin and taken to the laboratory for analysis. A total of fifteen species from four taxonomic group were identified in which chlorophyceae was the most abundant which ranged from 20.00±14.14 (station III) to 106.00±61.89 (station II) There was a significant difference ( $P < 0.05$ ) in the mean variation of chlorophyceae observed in all stations followed by Baccillariophyceae, with the mean range of 68.57±65.94 (station II) to 12.00±4.47 (station III), and Cyanophyceae that ranges from 40.00±28.28 (station III) to 70.00±28.28 (station II) The difference was not significant ( $P > 0.05$ ) in the mean variation of Baccillariophyceae and Cyanophyceae distributions in all the stations. While the lowest was Desmidiaceae. The high relative abundance of Chlorophyceae is an indication that the reservoir will support fish production.

**KEYWORDS:** GIS, Phytoplankton, GPS, Mapping, Quick Bird Satellite imagery

### INTRODUCTION

For a water body to be productive and generate high yield, the primary producers (phytoplanktons) of the water must be assessed because they are the main source of food directly or indirectly to the fish population and all the aquatic organisms as they form part of the aquatic ecosystem food web for their optimum performance. Phytoplanktons are essential component of the aquatic food chain (Janjua, et al., 2008). Phytoplanktons do not only influence the food chain but are also of economic value and biological significance to man (Araoye and Owolabi, 2005). Water quality share a mutual relationship with Phytoplankton as the later strongly influence water quality through carbon dioxide uptake and oxygen production. Changes in the water quality can also lead to change in the phytoplankton' distribution and abundance. The importance of phytoplankton and its structure as a means of determining the productivity of the Tagwai dam reservoir, as well as the well-being of the organisms of the water body calls for the Mapping of the phytoplankton in Tagwai dam reservoir using GIS which is a computerized mapping system that enables the user to spatially illustrate and interactively visualize statistical information about an area on a map was used because it has many advantages in that it provides the user an

instantaneous visualization of the distribution of phytoplankton in the dam reservoir in which the study was channelled on.

### METHODOLOGY

#### The study Area

The study was carried out for the period of six months (February to July 2016) and located on Tagwai dam reservoir in Chachanga Local Government area in southwest zone of Minna which is at the east of Tungan Goro about 10km, southeast of Mobil market and northeast of Paiko. It is an earthen dam constructed in the year 1978 by the Kano state water resources engineering construction agency (NSWB, 1991). The dam lies on the latitude 90 33' 35'' to 90 36' 07'' N and longitude 60 39' 20'' to 60 39' 58'' E. The dam is under the care of Niger State water board and serves as primary reservoir for Minna town water supply and a source of livelihood to riverine communities around it.

#### Sources of Data Acquisitions

Various methods and materials were used ranging from plankton net, plankton bottle, electronic microscope, centrifuge model 800, monograph for



phytoplankton identification, DO bottle for dissolve oxygen and B.O.D, GPSMAP 76 garmin product for coordinates measurement, secchi disc for transparency, fish finder 400C for depth and temperature measurement, pH meter for Potential Hydrogen Concentration, Chloride, Nitrate and Phosphate Determination were measured according to APHA (1995) standard procedures using Hach spectrophotometer model and GIS techniques to acquire the data for study. The data were obtained from two main sources which are primary data and secondary data. Primary data was data from measurement results of chemical-physical parameter of the water which was performed in situ or ex situ whose outcomes were analyses at the wet and dry laboratory of FUT, Minna, Niger State, Nigeria While the secondary data was data related to the location map and mapping of the phytoplankton, mapping was done with the aid of computer-assisted interpretation of Quick Bird Satellite imagery, Topographic map and research data from various report.

#### Data Analysis

All data collected were process and tabulated using Microsoft excel of 2010. The tabulated data were subjected to statistical analysis. Mean difference of parameters was compare using two-way ANOVA at  $P < 0.05$  to see the variations due to months and stations. While One-way ANOVA was used to see the station variation of phytoplankton.

#### RESULTS AND DISCUSSION

The result of Table 2 shows Phytoplankton community identified in Tagwai dam reservoir was characterized by four families which are Chlorophyceae represent by *Coscinodiscus* sp., *Lingulodinium polyedra* sp., *Pediastrum* sp., *Microspore* sp., *Gonatozygon* sp. and *Spirogyra* sp. Bacillariophyceae was represented by *Rhizosolenia* sp., *Pseudo-nitzschia australis* sp., *Proboscia alata* sp. *Fragillariopsis* sp. Cyanophyceae was represented by *Coelosphaerium* sp. and *Anabaena spirodes* sp. while Desmidiaceae was represented by *Closterium* sp.

The result (Table 3) depicts that the mean value of Chlorophyceae recorded which range from  $20.00 \pm 14.14$  (station III) to  $106.00 \pm 61.89$  (station II) There was a significant difference ( $P < 0.05$ ) in mean variation of Chlorophyceae observed in all stations. For Bacillariophyceae the mean range was from  $68.57 \pm 65.94$  (station II) to  $12.00 \pm 4.47$  (station III), while that of Cyanophyceae it ranges from  $40.00 \pm 28.28$  (station III) to  $70.00 \pm 28.28$  (station II) There was no significant difference ( $P > 0.05$ ) in the mean variation of Bacillariophyceae and Cyanophyceae distributions in all the stations.

The result which was display on the GIS map (Figure 3.). showed that high concentration of the three phytoplanktons (chlorophyceae, baccillariophyceae and Cyanophyceae) were in station II, moderately concentrated in station I and IV and low concentration in III. This high occurrence and relative abundance of phytoplankton in station II (site with vegetation) may be due to the farming activities in that region (eutrophication) and the plant nutrient washed into the dam reservoir via runoff which aid in growth of phytoplankton in the station and the low occurrence in station III (open water) may also be due to lack of nutrient that promote the growth of phytoplankton. The GIS query map result shows that Demidiaceae was present only in station 1 and absent in other (Figure 4 and Table 3).

#### The species attribute data

The result Figure 5 indicates that dam reservoir was dominated by Chlorophyceae followed by Bacillariophyceae then Cyanophyceae with Demidiaceae been the least representative in the dam. The presence of this phytoplankton in the reservoir indicates that the water is productive. The observation of more Chlorophyta than Bacillariophyta agrees to the trend in tropical water bodies (Akomeah et al., 2010). This result was also inclined with the work, Abdullahi and Indabawa (2005), on the phytoplankton content of Nguru Lake, Kolo et al (2010), on plankton communities of Tagwai Dam, Omondi et al (2016) on assessment of primary productivity of Kuinet Dam, Ahmed (2015) on determination of physic-chemical parameters and plankton composition in Wawan-Rafi Lake. Though the result disagrees with the result of Mustapha (2009) on limnological and assemblages of Oyun Reservoir in which the Bacillariophyceae was the dominant phytoplankton group in the reservoir.

#### CONCLUSION AND RECOMMENDATIONS

##### Conclusion

This study identified four groups of phytoplankton which include the Chlorophyceae, Bacillariophyceae, Cyanophyceae and Demidiaceae in Tagwai dam reservoir. It also identified Tagwai dam reservoir as a water body with potentials to support fish life due to the presence and abundance of the Chlorophyceae group of phytoplankton.

##### Recommendation.

There is need for periodic and continuous analysis of the composition and distribution of phytoplankton in Tagwai dam reservoirs. This will serve as an indicator of its productivity status as well as provide data needed for its effective management.

#### ACKNOWLEDGEMENTS



The Federal University of Technology, Minna and the Department of Water Resources, Aquaculture and Fisheries Technology are greatly appreciated for providing the enabling academic environment for the conduct of this study. Also, the Niger State Government through the Ministry of Water resources always deserve our commendation for giving us unhindered access to the water body.



**Table 1: Description of the Sampling point**

Sampling point	Location	Description	Longitudes X	Latitudes Y
1	Landing site	Landing site for fishers and where domestic activities take place	09°34.321"	06°39.159"
2	Site with vegetation	The site is very close to the reservoir where farming activities were carried out	09°34.558"	06°39.377"
3	open water	The middle part of the reservoir where all tributaries empty their water.	09°34.178"	06°39.600"
4	Dam site	This site is close to the dam outlet.	09°33.991"	06°39.419"

**Source:** Researcher compilation 2016

**Table 2: Phytoplankton species identified across the Stations**

Taxa	Station I	Station II	Station III	Station IV
<b><u>Chlorophyceae</u></b>				
<i>Coscinodiscus sp</i>	+	++	-	-
<i>Lingulodinium polyedra sp</i>	+	+	+	+
<i>Pediastrum sp</i>	-	+	-	-
<i>Microspora sp</i>	+	+	-	+
<i>Gonatozygon sp</i>	++	+	+	+
<i>Spirogyra sp</i>	++	++	-	+
<b><u>Baccillariophyceae</u></b>				
<i>Rhizosolentia sp</i>	+	+	-	-
<i>Nitzschia sp</i>	++	+++	+	+
<i>Proboscia sp</i>	-	++	-	+
<i>Fragillariopsis sp</i>	+	+	-	+
<i>Navicula sp</i>	+	+	-	+
<i>Thalassirora sp</i>	++	+	-	-
<b><u>Cyanophyceae</u></b>				
<i>Coelosphaerium</i>	+	++	+	+
<i>Anabaena sp</i>	+	++	-	++
<b><u>Desmidiaceae</u></b>				
<i>Closterium sp</i>	++	-	-	-

- = absent, + = sparse, ++ = abundant and +++ = dominant

**Table. 3: Station Variation of Phytoplankton distribution**

Species	Station I	Station II	Station III	Station IV
<i>Chlorophyceae</i>	74.00±31.30 <sup>ab</sup>	106.00±61.89 <sup>b</sup>	20.00±14.14 <sup>a</sup>	68.00±34.21 <sup>ab</sup>
<i>Baccillariophyceae</i>	55.71±44.29 <sup>a</sup>	68.57±65.94 <sup>a</sup>	12.00±4.47 <sup>a</sup>	48.57±37.16 <sup>a</sup>
<i>Cyanophyceae</i>	50.00±28.28 <sup>a</sup>	70.00±28.28 <sup>a</sup>	40.00±28.28 <sup>a</sup>	60.00±28.28 <sup>a</sup>
<i>Desmidiaceae</i>	90.00 <sup>a</sup>			

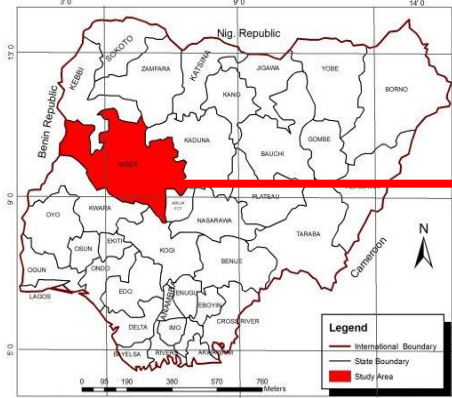


Figure 1a: Nigeria showing Niger state

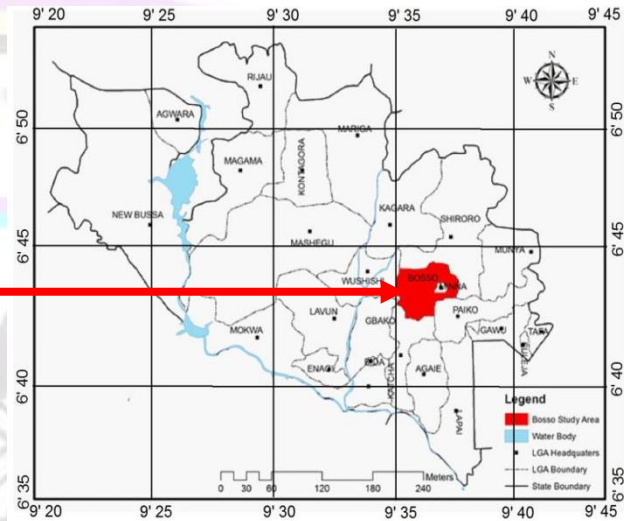


Figure 1b: Niger State showing Chanchaga in Bosso Local Government Area

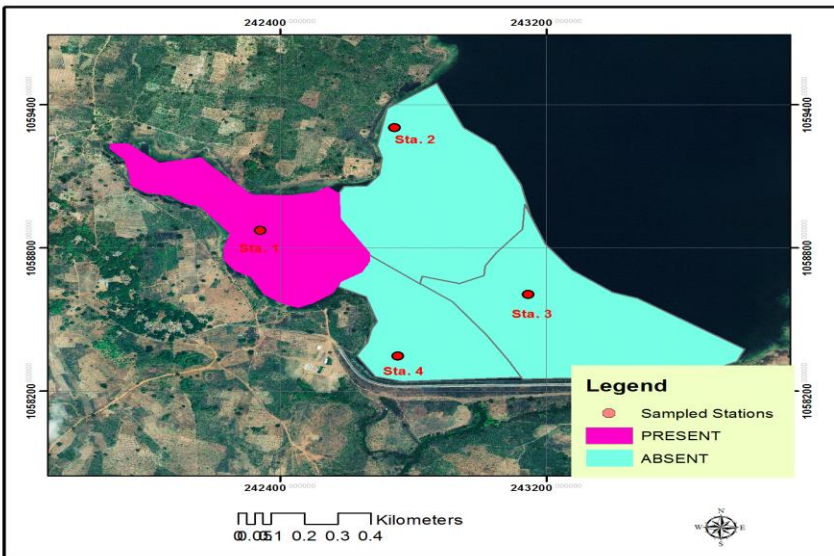
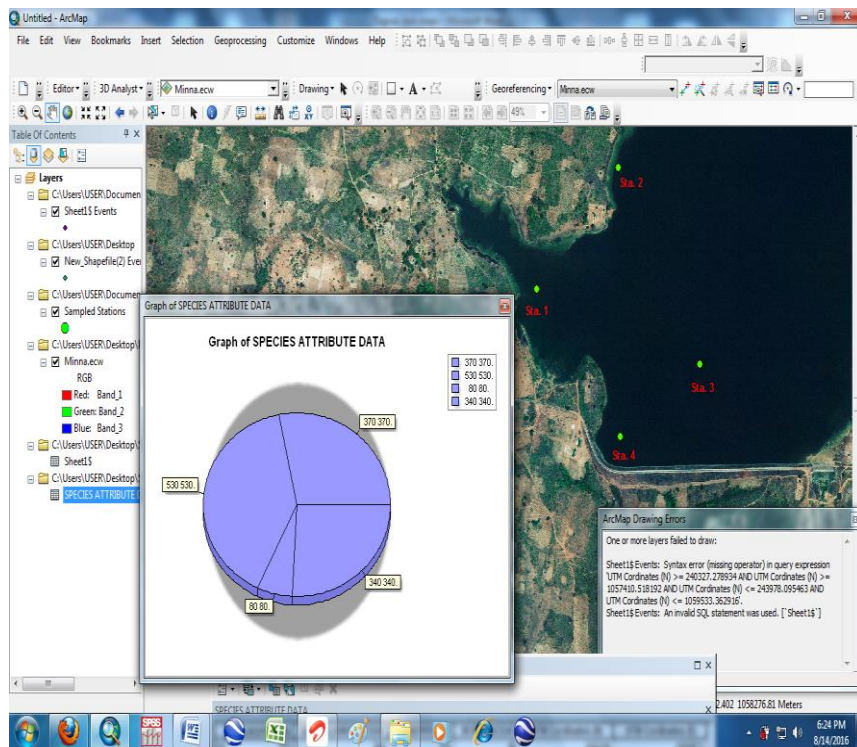


Figure 4: GIS Map of Tagwai Dam Reservoir Indicating the distribution of Desmidiaceae





**Figure 5: Database map of the study Area showing the phytoplankton attributes**

## REFERENCES

- Abdullahi, B. A and Indabawa, I. I. (2005) Ecology of Freshwater Phytoplankton of River Hadejia, Jigawa state. *Biological and Environmental Sciences journal for the tropics*. 1(2):141-145.
- Ahmed U. (2015), Determination of Physico-Chemical Parameters and Plankton Composition of Wawa-Rafi Lake in Kazaure, Nigeria, Department of Biological Sciences, Faculty of Science, Ahmadu Bello University, Zaria, Nigeria.
- Akomeah, P. A., Ekhator O. and Udoka C. (2010). Dry season phytoplankton composition of Ibiekuma dam, Edo State. *Ethiopian J. Env. Stud. Manage.* 3(3): 36-40.
- APHA (1995). American public Health Authority. Standard methods for examination of waters and waste waters. 16th Ed. Washington D.C pp 1193.
- Araoye, P. A. and Owolabi O. (2005). Some changes in the animal and fish species composition due to the construction of Kampe (Omi) dam and irrigation project in Kogi State, Nigeria. *Nigerian Journal of Pure & Applied Sciences*. 20: 1781-1789.
- Kolo, R. J, Ojutiku, R.O and Musulmi, D.T. (2010), Plankton Communities of Tagwai Dam Minna, Nigeria Continental. *Journal Fisheries and Aquatic Science* 4: 1 - 7, 2010 ISSN: 2141 - 4246 © Wilolud Journals <http://www.wiloludjournal.com>
- Mustapha M. K. (2009). Limnology and Fish Assemblages of Oyun Reservoir, Nigeria. [moonstapha@yahoo.com](mailto:moonstapha@yahoo.com)
- NSWB (Niger State Water Board) (1978) The Feature Data of The Tagwai Dam After Construction.
- Omondi O. Gilbert. O. R. and Ngodhe S. O. (2016) Assessment of Primary productivity, Nutrient levels and trophic status of Kuinet dam, Kenya. *International Journal of Fisheries and Aquatic Studies*; 4(3): 45-51, ISSN: 2347-5129 (ICV-Poland) Impact Value: 5.62 (GIF) Impact Factor: 0.352 *IJFAS* 2016; 4(3): 45-51 © 2016 *IJFAS* [www.fisheriesjournal.com](http://www.fisheriesjournal.com).

## INTERACTIONS BETWEEN CROP GENOTYPIC DIVERSITY AND TILLAGE

\* Adekanmbi A.A.<sup>1,2</sup> and D. Johnson<sup>1</sup>

<sup>1</sup> Institute of Environmental and Biological Sciences, University of Aberdeen, Cruickshank building, St. Machar Drive, Aberdeen AB24 3UU

<sup>2</sup> Soil Science and Land Management Department, Federal University of Technology, P.M.B 65 Minna, Nigeria.

\*Corresponding Author's E-mail: [alexuniji1@yahoo.co.uk](mailto:alexuniji1@yahoo.co.uk) GSM: +447435369507

### ABSTRACT

*Tillage is an important crop management practice and a major factor for consideration in the managements of plant-microbe interactions in agro-ecosystems. Interactions between tillage and different crop genotypes or their combinations were evaluated to assess plant nutrient acquisition, shoot and root biomass and mycorrhizal colonization of different barley genotypes in agricultural soil. The results showed that, tillage and genotypic diversity differentially affect plant nutrient acquisition and biomass accumulation of barley grown in tillage affected agricultural soils at early growth stage. In this study, we present the that, genotypic diversity support more nutrient acquisition and biomass accumulation in spring barley compared to winter types at early growth stage. Presence of keystone genotype among different combination shapes the functioning and productivity in terms of biomass accumulation and nutrients acquisition. Although, minimum tillage increased tissue nitrogen, phosphorus concentration and their total uptake by plant, a salient fact in this study is the increased tissue concentration of phosphorus in barley genotypes grown in conventional tilled soil, indicating the need to study into other factors that may be responsible for increased P concentration in barley grown on soils from contrasting tillage systems since there is no quantifiable evidence of mycorrhizal activity in soil.*

**KEYWORDS:** Tillage, plant genotype, nutrient acquisition, sustainable land use

### INTRODUCTION

Modern farming is increasingly using reduced tillage systems, where shallower layers of soil are cultivated as a means to save energy and possibly decrease impacts on soil quality. Due to different mixing of soil and the development of shallow plough pans, the soil environment for root growth can be very different between reduced tillage and conventional systems using deeper inversion cultivation. Key soil organisms such as arbuscular mycorrhiza fungi may be less disturbed under reduced tillage. Moreover, as the variation in the reproductive and functional attributes of different crop genotype is driven by both genetic and environmental factors (Johnson et al., 2012), there may be a genotype specific response to soil tillage systems.

Most breeding trials in Europe including Scotland are based on soil cultivated under conventional tillage system, disturbing soil to at least 20 cm depth. However, most studies on potential impacts of tillage and barley genotypes in Scotland have focused mainly on growth, yield and disease resilience of the system (Newton et al., 2012). In this study, we investigate whether the interactions between tillage and different crop genotypes or their combinations

affect plant nutrient acquisition, shoot and root biomass and mycorrhiza colonization of different barley genotypes in agricultural soil from North East Scotland.

### METHODOLOGY

Soil cores were collected from a tillage experiment at Pilmore station of James Hutton Institutes (JHI), Invergowrie, Dundee. The soil cores were carefully collected at random from three replicated minimum and conventional tillage treatment plots at 0 - 15 cm depth with little or no physical disturbance as described by Schalamuk et al. (2011). Each soil core was carefully placed in a 1000cm<sup>3</sup> rectangular plastic pot and then taken to the greenhouse of the School of Biological Sciences, University of Aberdeen, Scotland where the study was carried out. The tillage experiment at Pilmore was established in 2003 and has since been cultivated to both the winter and spring barley which is one of the economic cereal crop in the UK. The minimum tillage treatment disturbs soil yearly at 7 cm depth, while the conventional tillage treatment at 20 cm depth. The



detail about the tillage treatments and their replicate plots are reported by Newton et al. (2012).

The greenhouse study consisted of two different experiment; i) to evaluate the interactions between tillage and different crop genotypes (Genotypic differences – T x G) and ii) to assess the interactions between tillage and combinations of different genotypes (Genotypic richness – T x GR). The two experiments were carried out simultaneously under temperate condition. Experiment I consist of a 4 x 2 factorial combinations of crop genotype and tillage in a Completely Randomized Design (CRD). Four different genotypes developed as cultivated varieties in UK (Lima grain, UK) were used for this study and identified as G1, G2, G3, and G4 respectively. The genotypes includes; G1 – Carat (winter barley), G2 – Scout (spring barley), G3 – Pearls (winter barley) and G4 – Westminster (spring barley) respectively. The tillage treatments were minimum (Min.) tillage (T1) and conventional (Con.) tillage (T2). The treatments were laid out in three replicates which represent the field experimental conditions from where the soil samples were collected. Experiment II was a 3 x 2 factorial combinations consisting of three different crop genotype combinations in three places randomly selected from the four genotypes at two tillage methods in CRD as in experiment I above. The genotypic combination (richness) were denoted as; X = G1+G2+G3, Y = G2+G3+G4, and Z = G1+G2+G4. Three replications were performed as in experiment I.

The soil at Pilmore is a Dystric-Fluvis Cambisol with a sandy loam texture, freely drained and underlain by colluvial sand at 60 cm depth (Bell and Hipkin, 1988 and Newton et al., 2012). Baseline measurement of soil was carried out to determine the pH, plant available nitrogen ( $\text{NO}_3\text{-N}$  and  $\text{NH}_4\text{-N}$ ) and phosphorus ( $\text{PO}_4\text{-P}$ ) and total N and carbon (C) from bulked soil samples collected at 0 -15 cm depth. Atleast, 3 – 4 randomly selected points were sampled from each replicate plot to obtain a bulk sample. The samples were air-dried at 25°C and sieved using 2mm diameter sieve and then stored in the cold room at 4°C or analyzed immediately. To measure the total N and C, soil samples were oven dried at 105°C (overnight), ball milled and then analyzed. For the assessments of plant available N and P, 1 M KCl and

2.5% acetic acid extracts were analyzed using FIA star 5000 Foss Tecator. Soil pH was also determined at 2:1 water to soil by volume (Allen, 1989).

Planting was done as laid out in each experiment in the greenhouse. On 1<sup>st</sup> June, 2015, 4 day old seedlings pre-germinated in pure sand were transplanted into pots as laid out in experiment I and II above. Prior to transplanting, each pot was watered to equilibrate the soil at field capacity. In experiment I, 3 seedlings were transplanted to each plastic pot to obtain 3 within genotype population per pot. But in experiment II, 1 seedling each from each genotype in combination was transplanted to obtain 3 different genotypes per pot. The plants were grown for four weeks without nutrient addition, but watered regularly to avoid water stress during the growth period.

During the growing period, plant height ( $\text{cm plant}^{-1}$ ) was recorded using a meter rule at 1, 2, 3, and 4 weeks after transplanting (WAT) respectively. Plants were harvested after four weeks. The shoot of the individual plant within each pot was separated from the root and the root within each pot was collected after washing off its adhering soil with tap water. Oven-dried mass of the shoot ( $\text{g plant}^{-1}$ ) and root per pot (g) obtained were recorded after drying at 60°C for 24 hours. To obtain shoot biomass per pot (g), shoot dry mass ( $\text{g plant}^{-1}$ ) of each individual plant within each pot was added together. Total biomass per pot ( $\text{g pot}^{-1}$ ) was obtained from the addition of shoot and root biomass per pot ( $\text{g pot}^{-1}$ ). The ratio of root to shoot in each pot was also determined. The dried root samples were stored until further analysis for root length colonization by AM fungi.

The acid digests (sulphuric acid and hydrogen peroxide) from dried, milled and homogenized subsamples of shoots collected per plant were analyzed using flow injection auto-analyzer (FIA star 5000, Foss Tecator, Denmark) to measure tissue N and P concentrations ( $\text{mg N g}^{-1}$ ). To obtain total N or P uptake ( $\text{mg N}$  or  $\text{mg P plant}^{-1}$ ), shoot dry mass ( $\text{g plant}^{-1}$ ) was multiplied by its respective tissue N or P concentrations. Analysis of root colonization was done by calculating the percentage root length colonized using the magnified intersection method (McGonigle et al., 1990).

## RESULTS AND DISCUSSION



**Soil baseline characteristics** Tillage practice significantly influence soil characteristics measured. Soil pH ( $F_{1,4} = 42.43$ ;  $P = 0.003$ ), available P ( $F_{1,4} = 28.54$ ;  $P = 0.006$ ) and  $\text{NO}_3\text{-N}$  ( $F_{1,4} = 40.35$ ;  $P = 0.003$ ) were significantly higher under minimum tillage than conventional tillage (figure 1), whereas, there was no significant difference in  $\text{NH}_4\text{-N}$ , total N and C between the two tillage systems.

**Effects of tillage and genotypic differences on barley N and P acquisition** Tillage significantly influenced tissue N ( $F_{1,64} = 202.85$ ;  $P = 0.0001$ ) and P ( $F_{1,64} = 47.28$ ;  $P = 0.0001$ ) concentration and total N ( $F_{1,64} = 99.70$ ;  $P = 0.0001$ ) and P ( $F_{1,64} = 20.82$ ;  $P = 0.0001$ ) uptake of barley crop respectively (Figure 2). Tissue N concentration (figure 2d), total N (figure 2c) and P (figure 2a) uptake were significantly higher under minimum tillage compare to the conventional system. This culminate into a 50%, 220%, and 59% increases in tissue N, total N and total P respectively. Conversely, tissue P concentration was 16% higher under conventional tillage compared to minimum tillage system (figure 2b). Similarly, there was a significant differences in tissue N ( $F_{3,64} = 24.64$ ;  $P = 0.0001$ ) and P ( $F_{3,64} = 15.89$ ;  $P = 0.0001$ ) concentration, and total N ( $F_{3,64} = 6.47$ ;  $P = 0.001$ ) uptake of different barley genotypes, though a significant interaction ( $F_{3,64} = 7.68$ ;  $P = 0.0001$ ) of tillage and genotype was found only in tissue P concentration. Tissue N concentration was high in cv. Westminster (G4) ( $16.10 \text{ mg N g}^{-1}$ ) compared to the other genotypes (figure 2d). there was 85% increase in total N uptake of cv. Westminster above that of cv. Pearl and this was similar to that of cv. Carat. Due to the interactions in tissue P concentration, cv. Westminster (G4) had the highest concentration ( $5.81 \text{ mg P g}^{-1}$ ) when cultivated under conventional tillage which was similar to cv. Pearl (G3) under the same tillage condition. Whereas, cv. Scout (G2) had the lowest tissue P concentration ( $3.54 \text{ mg P g}^{-1}$ ) under minimum tillage similar to cv. Westminster under the same tillage system (figure 2b). The cv. Westminster and Scout took up more Total N than cv. Pearl similar to cv. Carat respectively. The results here implies that, N and P accumulation and distribution with the plants was favoured by minimum tillage. This result may be a results of higher available N and P at the surface soil as reported by (Małecka *et al.*, 2012), though this depend on the individual genotype. Generally, minimum tillage increased nutrient uptake of barley

genotypes differentially. This is in contrast with the report of Ishaq *et al.*(2001), that there is no significant differences in wheat tissue N and P contents under contrasting tillage systems at tillering stage.

Each genotype as a component of each genotype combination was examined for their nutrient acquisition under varying tillage systems (Table 1). The results showed that, tillage and genotype significantly influenced tissue and total N and P. Conventional tillage significantly reduced tissue N ( $F_{1,30} = 69.71$ ;  $P = 0.0001$ ), total N ( $F_{1,30} = 44.46$ ;  $P = 0.0001$ ) and P ( $F_{1,30} = 13.91$ ;  $P = 0.002$ ) uptake by 39%, 61% and 30% respectively, but increased tissue P concentration ( $F_{1,30} = 6.27$ ;  $P = 0.024$ ) by 19%. There was a significantly high total N ( $F_{3,30} = 15.95$ ;  $P = 0.0001$ ) and P ( $F_{3,30} = 11.78$ ;  $P = 0.0001$ ) uptake in cv. Scout compared to cv. Carat, Pearl and Westminster, but acquired significantly low ( $F_{3,30} = 13.16$ ;  $P = 0.0001$ ) tissue P concentration when it is grown in combination with others. Genotypic difference did not affect tissue N concentration and there was no significant interactions between tillage and genotype in all the nutrient parameters measured. This results agrees with the principle of intraspecific diversity. That is, intraspecific diversity could have substantial effects on ecosystem functioning when genetic diversity of one species directly affects the abundance, distribution and functioning of a key stone species or reflected by trait diversity under varying environments (Johnson *et al.*, 2012).

**Influence of Tillage and genotypic difference on shoot and root dry biomass** Effect of Tillage was significant in shoot ( $F_{1,16} = 65.19$ ;  $P = 0.0001$ ), root ( $F_{1,16} = 33.87$ ;  $P = 0.0001$ ) and total biomass ( $F_{1,16} = 68.04$ ;  $P = 0.0001$ ) per pot respectively, but did not affect root/shoot ratio. This resulted in 96%, 67% and 82% increase in shoot, root and total biomass under minimum tillage compared to the conventional system respectively. Also, genotype variation significantly influenced shoot biomass ( $F_{3,16} = 5.53$ ;  $P = 0.008$ ), root biomass ( $F_{3,16} = 5.45$ ;  $P = 0.009$ ) and root/shoot ratio ( $F_{3,16} = 39.42$ ;  $P = 0.0001$ ) respectively, but not total biomass. The cv. Scout accumulated more shoot ( $0.899 \text{ g pot}^{-1}$ ) than  $0.542 \text{ g pot}^{-1}$  recorded for cv. Pearl (figure 3d). Conversely, root biomass was higher in cv. Pearl and cv. Carat, but lower in cv. Westminster. A similar trend was observed in root/shoot ratio where cv. Pearl and cv. Carat expressed more ratio compared to the others. There was no significant interactions between tillage

and barley genotype in plant biomass parameters tested, but minimum tillage supported more biomass accumulation than the conventional system. This implies that minimum tillage support biomass accumulation compare to conventional tillage. This is in agreement with the results reported in Manitoba, Canada where conventional tillage reduced flax root biomass (Monreal et al., 2010).

**Genotype combination and richness as affected by tillage system** Figure 4 represent the effects of tillage and genotype combination on plant biomass accumulation of barley crop (to examine how tillage interact with different combination of barley genotype). In all, tillage significantly influenced shoot ( $F_{1,12} = 26.21$ ;  $P = 0.0001$ ), root ( $F_{1,12} = 24.14$ ;  $P = 0.0001$ ) and total biomass ( $F_{1,12} = 34.42$ ;  $P = 0.0001$ ) per pot, but did not affect root/shoot ratio. Minimum tillage supported high accumulation of shoot (Figure 4d), root (Figure 4c) and total biomass (Figure 4b) irrespective of the combination. Genotype combination did not influence plant biomass parameters except in root/shoot ratio (Figure 4a) where cv. Carat-Scout-Pearl (X) combination accumulated more biomass than Y and Z respectively.

We examined whether genetically diverse combinations of plants produced more biomass ( $\text{g pot}^{-1}$ ) compared to genetically impoverished populations (single genotype individuals; Table 2) in different tillage systems. It was found that, single effect of tillage significantly influenced shoot, root and total biomass, but did not affect the root/shoot ratio. Minimum tillage system supported high shoot ( $F_{1,28} = 68.78$ ;  $P = 0.0001$ ), root ( $F_{1,28} = 58.00$ ;  $P = 0.0001$ ) and total biomass ( $F_{1,28} = 76.20$ ;  $P = 0.0001$ ) accumulation compared to conventional tillage. This amount to 44% and 39% increase in shoot and root biomass under minimum tillage. Also, genotypic richness significantly increased shoot biomass ( $F_{6,28} = 4.10$ ;  $P = 0.004$ ), root biomass ( $F_{6,28} = 3.65$ ;  $P = 0.008$ ) and root/shoot ratio ( $F_{6,28} = 22.02$ ;  $P = 0.0001$ ), but did not affect total biomass per pot. Combination consisting of cv. Scout-Pearl-Westminster (Y) and single genotype cv. Scout (G2) produced more shoot compared to cv. Pearl (G3). Also, combination consisting cv. Carat-Scout-Pearl (X), single genotypes cv. Carat (G1) and cv. Pearl (G3) produced more root biomass compared to cv. Westminster (G4). In terms of root/shoot ratio, cv. Pearl (G3) expressed higher ratio similar to that of G1, but lower ratios were recorded from cv. Scout

(G2), Westminster (G4) and combination cv. Carat-Scout-Westminster (Z) similar to that of cv. Carat-Scout-Westminster (Y) combination. There were no significant interactions between tillage and genotypic richness in all the biomass and the ratio. The result did not support the hypothesis that genotypic diverse population produced more biomass than genotypic impoverished populations due to complementarity since they accumulated similar shoot, root and total biomass whether in combination or monoculture. This is line with the results of the root traits which reveals little or no cultivars' complementarity reported from field study at the same site (Newton et al., 2012).

## CONCLUSION AND RECOMMENDATIONS

In conclusion, this study has shown that tillage and genotypic diversity differentially affects plant nutrient acquisition and biomass accumulation of barley in the early stages of growth. The findings suggest that, since there is no evidence of mycorrhizal fungi activity in the soil, there may be other factors responsible for increased P concentration in barley grown on soils from contrasting tillage systems. In this study, we present the evidence that, genotypic diversity support more nutrient acquisition and biomass accumulation in spring barley compared to winter types at early growth stage. We recommend that minimum tillage barley plants with superior traits (nutrient acquisition) be adopted under barley production in the study area.

## ACKNOWLEDGEMENTS

This work and my MSc. Soil Science programme were sponsored by the Commonwealth Scholarship Commission, UK.

**Table 1: Analysis of tillage and within genotype combinations on plant nutrient acquisition**

Treatment	Tissue N ( mg g <sup>-1</sup> )	Total N ( mg N plant <sup>-1</sup> )	Tissue P (mg P g <sup>-1</sup> )	Total P (mg P plant <sup>-1</sup> )
Tillage (T)				
Min.	17.253a	5.409a	3.729b	1.155a
Con.	10.601b	2.095b	4.451a	0.806b
Genotype (G)				
G1	14.092a	3.796b	4.113a	0.954b
G2	13.012a	5.743a	3.490b	1.505a
G3	13.745a	2.922b	4.573a	0.832b
G4	14.850a	2.548b	4.183a	0.632b
T x G	ns	ns	ns	ns
P - Values				
Tillage (T)	0.000**	0.000**	0.024*	0.002**
Genotype(G)	0.210ns	0.000**	0.000**	0.000**
Pot(Tillage)	0.121ns	0.112ns	0.000**	0.827ns
T x G	0.094ns	0.912ns	0.141ns	0.914ns
Error df	30	30	30	30

Means that shares the same letter within a column are not significantly different; ns = not significant (P < 0.05)

\*\* = P < 0.01 , \* = P < 0.05

**Table 2: Combined analysis of the effects of tillage and genotypic combinations (richness) on biomass accumulation**

Treatment	Shoot biomass / pot ( g pot <sup>-1</sup> )	Root biomass/pot ( g pot <sup>-1</sup> )	Total biomass/pot ( g pot <sup>-1</sup> )	Root/Shoot biomass
Tillage (T)				
Min.	0.978a	0.876a	1.854a	0.955a
Con.	0.549b	0.534b	1.084b	1.021a
Genotype Richness (GR)				
G1	0.623ab	0.793a	1.416a	1.308ab
G2	0.899a	0.617ab	1.516a	0.698d
G3	0.542b	0.810a	1.351a	1.514a
G4	0.770ab	0.522b	1.292a	0.708d
X	0.768ab	0.820a	1.588a	1.105bc
Y	0.919a	0.727ab	1.646a	0.796cd
Z	0.826ab	0.646ab	1.471a	0.786d
T x GR	ns	ns	ns	ns
P - Values				
Tillage (T)	0.000**	0.000**	0.000**	0.216ns
Genotype Richness (GR)	0.004**	0.008**	0.351ns	0.000**
T x GR	0.117ns	0.966ns	0.522ns	0.658ns
Error df	28	28	28	28

Means that shares the same letter within a column are not significantly different; ns = not significant (P ≤ 0.01)

\*\* = P < 0.01 , \* = P < 0.05

X (G1 + G2 + G3), Y (G2 + G3 + G4) or Z (G1 + G2 + G4) = Genotypic combination



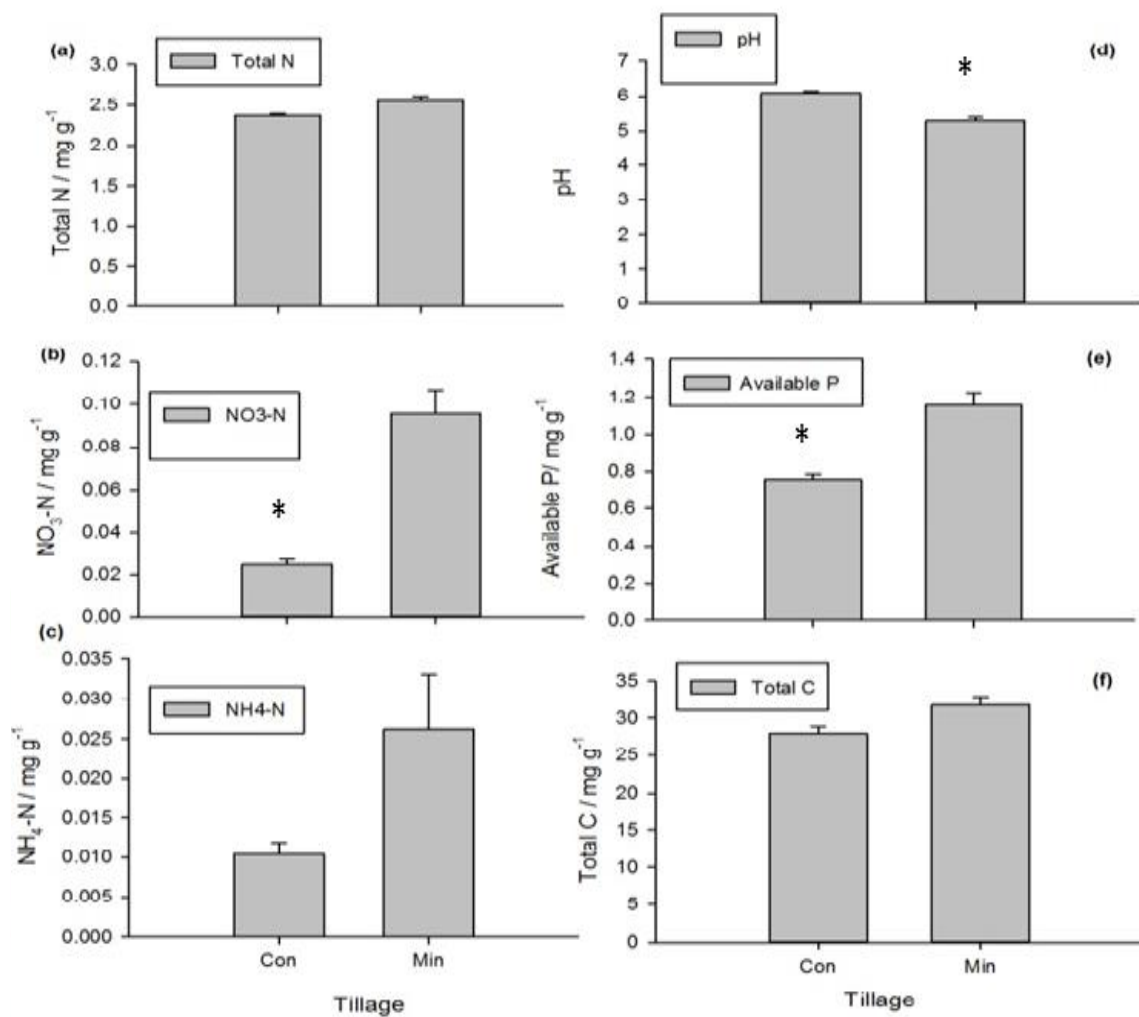


Figure 1 – Baseline Soil characteristics showing soil Total N (mg g<sup>-1</sup>) (a), NO<sub>3</sub>-N (mg g<sup>-1</sup>) (b) NH<sub>4</sub>-N (mg g<sup>-1</sup>) (c), pH (d), Available P (mg g<sup>-1</sup>) (e), and Total C (mg g<sup>-1</sup>) (f). Error bar = SE; asterisk indicate bars that are significantly different between tillage systems (P < 0.01). Min. = Minimum; Con. = Conventional.

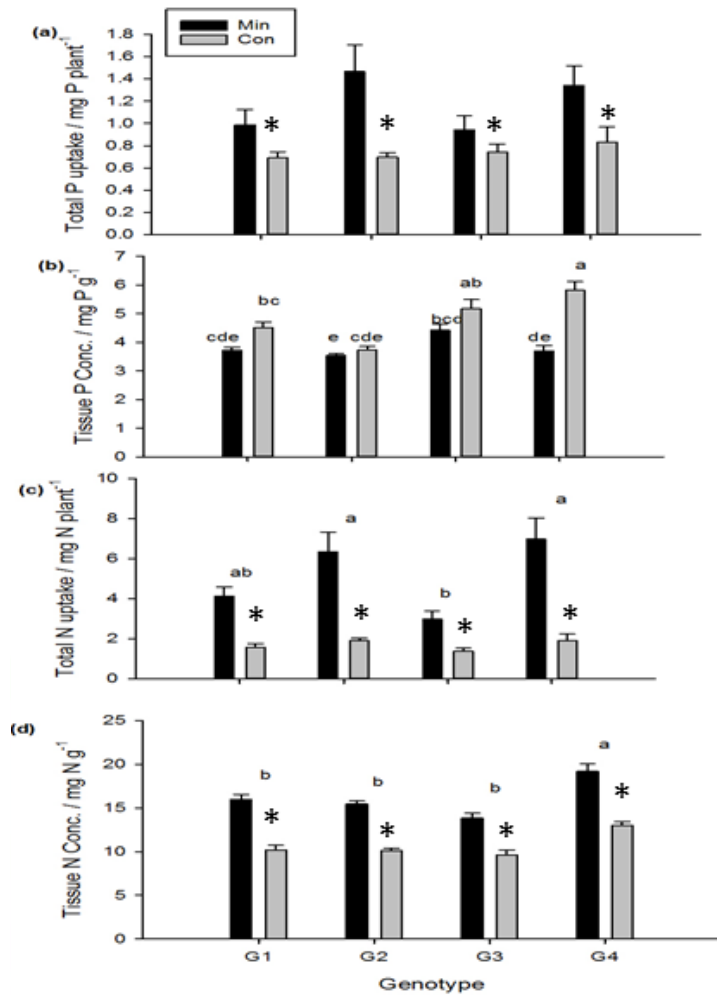


Figure 2: Effects of tillage and genotypic differences on nutrient acquisition. (a) Main effects of tillage and genotype on Total P (mg P plant<sup>-1</sup>); (b) interaction effect on Tissue P (mg P g<sup>-1</sup>); (c) main effects of tillage and genotypes on Total N (mg N plant<sup>-1</sup>); (d) main effects of tillage and genotypes on Tissue N (mg N g<sup>-1</sup>). Error bar = SE; Bars (Means) that do not share a letter (only genotype or interaction effects) are significantly different from each other ( $P < 0.01$ ); asterisks indicate bars that are significantly different between tillage systems ( $P < 0.01$ ). G1 = Carat; G2 = Scout; G3 = Pearls; G4 = Westminster. Min. = Minimum; Con. = Conventional.

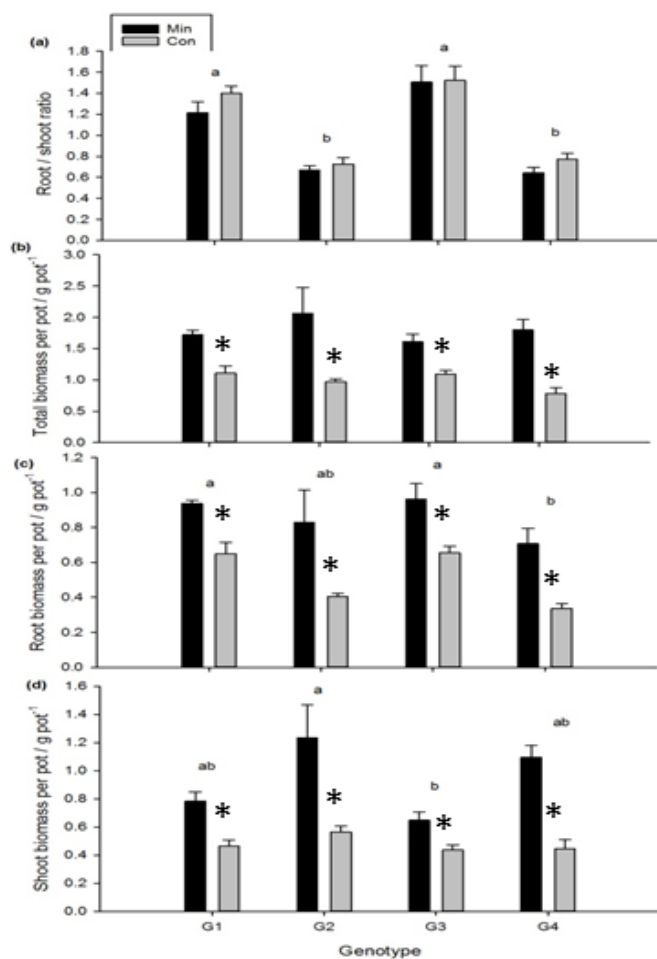
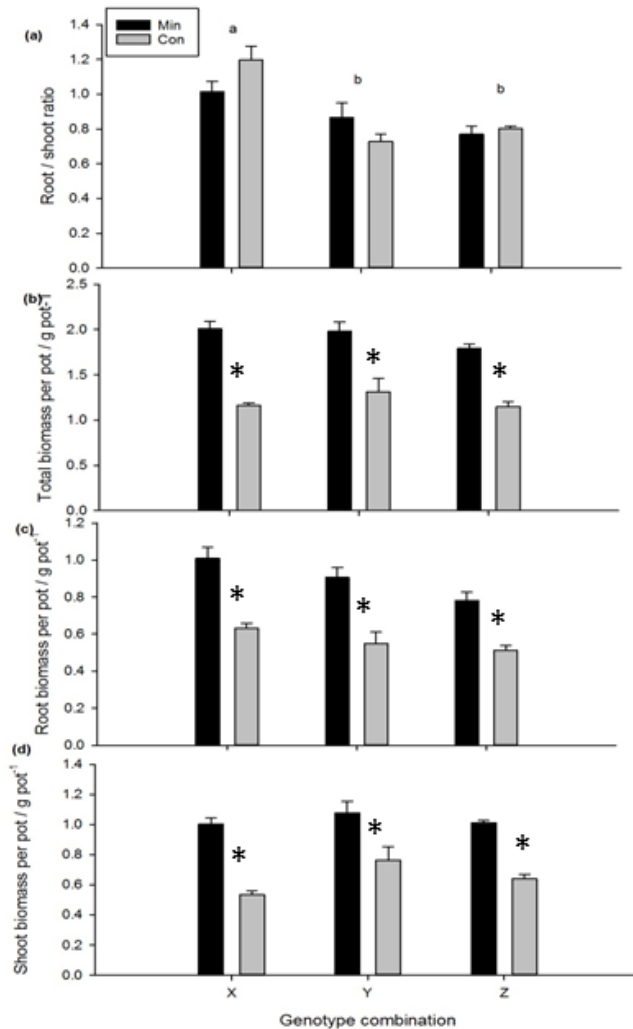


Figure 3 – Effects of tillage and genotypic differences on plant biomass accumulation. (a) Main effect of genotype on root/shoot ratio; (b) main effect of tillage on total biomass / Pot (g pot<sup>-1</sup>); (c) main effects of tillage and genotype on root biomass / pot (g pot<sup>-1</sup>) and (d) main effects of tillage and genotype on shoot biomass / pot (g pot<sup>-1</sup>). Error bar = SE; Bars (Means) that do not share a letter (only genotype effects) are significantly different from each other ( $P < 0.01$ ); asterisk indicate bars that are significantly different between tillage systems ( $P < 0.01$ ). G1 = Carat; G2 = Scout; G3 = Pearls; G4 = Westminster. Min. = Minimum; Con. = Conventional.





**Figure 4 - Effects of tillage and genotype combination on plant biomass accumulation. (a) Main effect of genotype on root/shoot ratio (b) main effect of tillage on total biomass / Pot (g pot<sup>-1</sup>); (c) main effects of tillage on root biomass / pot (g pot<sup>-1</sup>) and (d) main effects of tillage on shoot biomass / pot (g pot<sup>-1</sup>). Error bar = SE; Bars (Means) that do not share a letter (only genotype effects) are significantly different from each other (P < 0.01); astericks indicate bars that are significantly different between tillage systems (P < 0.01). Min. = Minimum; Con. = Conventional; X (G1 + G2 + G3), Y (G2 + G3 + G4) or Z (G1 + G2 + G4) = Genotypic combination. G1 = Carat; G2 = Scout; G3 = Pearls; G4 = Westminster.**

## REFERENCES

- Allen, S.E., Grimshaw, H.M., Parkinson, J.A. and Quarmby, C., 1974. *Chemical analysis of ecological materials*. Blackwell Scientific Publications..
- Bell, J. and Hipkin, J., (1988). Soils of Mylnefield and Gourdie Farms. *Scottish Crop Research Institute. Macaulay Land Use Research Institute, Aberdeen*
- Ishaq, M., Ibrahim, M. and Lal, R., 2001. Tillage effect on nutrient uptake by wheat and cotton as influenced by fertilizer rate. *Soil and Tillage Research*, **62**(1), pp. 41-53.
- Johnson, D., Martin, F., Cairney, J.W. and Anderson, I.C., (2012). The importance of individuals: intraspecific diversity of mycorrhizal plants and fungi in ecosystems. *New Phytologist*, **194**(3), pp. 614-628.

- Małeczka I, Blecharczyk A, Sawinska Z, Dobrzeńiecki T. The effect of various long-term tillage systems on soil properties and spring barley yield. *Turkish Journal of Agriculture and Forestry*. 2012;36(2):217–26
- Mcgonigle, T., Miller, M., Evans, D., Fairchild, G. and Swan, J., (1990). A new method which gives an objective measure of colonization of roots by vesicular—arbuscular mycorrhizal fungi. *New Phytologist*, **115**(3), pp. 495-501.
- Monreal, M., Grant, C., Irvine, R., Mohr, R., McLaren, D. and Khakbazan, M., (2011). Crop management effect on arbuscular mycorrhizae and root growth of flax. *Canadian Journal of Plant Science*, **91**(2), pp. 315-324.
- Newton, A., Guy, D., Bengough, A., Gordon, D., Mckenzie, B., Sun, B., Valentine, T. and Hallett, P., (2012). Soil tillage effects on the efficacy of cultivars and their mixtures in winter barley. *Field Crops Research*, **128**, pp. 91-100.
- Prosser, J.I., Bohannan, B.J., Curtis, T.P., Ellis, R.J., Firestone, M.K., Freckleton, R.P., Green, J.L., Green, L.E., Killham, K. and Lennon, J.J., (2007). The role of ecological theory in microbial ecology. *Nature Reviews Microbiology*, **5**(5), pp. 384-392.
- Stockdale, E. and Joint Nature Conservation Committee, (2006). Do farm management practices alter below-ground biodiversity and ecosystem function: implications for sustainable land management? [envia.bl.uk](http://envia.bl.uk) (accessed 29 April 2015).



## DEVELOPMENT AND ASSESSMENT OF ROUND BOTTOM FERROCEMENT CANOE FOR ARTISANAL FISHERY IN KAINJI LAKE BASIN.

\* Ibrahim. A, \*\*R.J Kolo and \*\* S.O.E Sadiku

\*FISHERIES TECHNOLOGY DEPARTMENT FEDERAL COLLEGE OF FRESHWATER FISHERIES TECHNOLOGY, PMB1500 NEW BUSSA, NIGER STATE

\*\* DEPARTMENT OF WATER RESOURCES AQUACULTURE AND FISHERIES TECHNOLOGY, FEDERAL UNIVERSITY OF TECHNOLOGY MINNA, NIGERIA.

E-mail: [bigshaba@gmail.com](mailto:bigshaba@gmail.com), GSM: 08059779306

### ABSTRACT

*This paper contains information on the step-by-step design and construction process of round bottom ferrocement canoe in form of photo essay. The 4.7M length overall (LOA) round bottom canoe was designed and constructed using locally available materials which include; cement, fine aggregate sharp sand, water and iron reinforcement. The craft featured some advantages which include easy construction, adequate water tightness, durability, affordable cost, shallow draft and easy manoeuvrability and ability to withstand the wave action, as it drift less away from the course. The light displacement (weight empty) was 0.2 tonnes (200kg) when placed on water, the draft was 17cm. The capacity of the craft was 0.59 tonnes (590kg) and the total production cost was fifty one thousand five hundred Naira (N 51,500), which was not beyond the reach of an average fisher folks. The canoe was easily manoeuvred when propelled by paddling as it floated at a shallow draft; this makes the craft adequate for use on kainji lake basin. The craft surpasses the local canoe by adequate water tightness, stability and easy maintenance. The main construction material used (ferrocement) is environment friendly as deforestation could be highly reduced. The craft, because of its easy manoeuvrability, on assessment with the planked canoe, found to performed better and could gain local acceptance within the fisher forks around the kainji lake basin.*

**KEYWORDS:** Round bottom, Stability, water tightness.

### INTRODUCTION

The traditional dugout canoe used for fishing and marine transportation requires high-quality hardwood. With deforestation of many tropical coastal areas, these strong, workable, long-lived woods are increasingly scarce in many areas of the world, finding the type of timber needed to build a good quality wooden boat is becoming a problem hence boat construction is a growing problem for many small scale fishermen. Ferrocement can be defined as a composite material consisting of a matrix made from sand cement mortar and a number of layers of continuous steel mesh reinforcement distributed throughout the matrix (Riley and Turner (1995).

The canoes commonly used, that have replaced the dugout canoe are mostly flat bottoms that are characterized by heavy pounding on water body due to the strong wave action, most of the canoes have chines that are not adequately water tight making them float at drafts that are not safe, reducing their capacity and causing in flow of water through leakages and also there is little or no free board (Abubakar, 2006). Fishermen usually spend more on repairs and maintenance of their crafts adding to the total fishing cost, and spending part of their precious fishing time bailing out water from the crafts.

Fishing activity cannot be carried out effectively without fishing craft, this is due to the fact that the fisherman will be restricted to fishing along the shore or shallow areas only, which will lead to reduced fish catch (Ogundiwin, 2014). Floating platform that is adequate for transportation of the fishing crew, gear, and catch to and from the fishing ground is therefore necessary for effective fishing activity. Most of the modern crafts that were designed and constructed for use on Kainji lake, were produced with less regard to the fact that, a radical departure from the traditional hull designs may not gain local acceptance by the fisher folks (NRC, 1988). Vessels sizes and designs that have evolved in an area are usually adapted to the local fishing gear and methods. The type of craft the artisanal fishermen use are mostly flat bottom planked canoes that are characterized by poor performance on turbulent water body, which results into discomfort to the users and early damages causing higher spending on repairs and maintenance of crafts hence increase in the total fishing cost. The high cost of maintenance generally increases the cost of fish production through capture fisheries. Hence the introduction of round bottom ferrocement boat will serve to navigate, alleviate and improve upon the consequences associated with the present fishing crafts by the local



artisanal fisher folks. The objectives of this work are to:-

- i. Develop and assess a ferrocement canoe for kainji lake fishery with better efficiency.
- ii. Make the fishing canoe Safer and free from leakages that make fishermen spend part of their fishing time bailing out water.
- iii. Determine and compare the cost effectiveness of ferrocement canoe and the planked canoe.

## METHODOLOGY

### Canoe design process

To obtain the design data, a free hand sketch of the canoe was drawn putting in place all the required design lines and making all necessary adjustments. A metre rule was used to measure the specifications of the free hand sketch. This is in accordance with Abubakar (2006) adapted from Love (1979), who state that designs do not begin with T-square and drawing instrument, they begin with ideas nurtured on experience and on observations, then best developed by translating the mental picture thus formed into freehand sketches made with soft pencils. To obtain the shape of the canoe at each section, measurements were taken at each of the sections then projected accordingly. The points of interceptions at sheer height above base (sheer HA/B) and sheer half breadth (sheer H/B) were joined with straight lines to the points of interceptions at chine height above base (chine HA/B) and chine half breadth (chine H/B) points, at the two sides of the centerline. The two sides were then joined with straight lines to the keel to form the shape of the canoe at the section. Combination of the projected sections constituted the body plan of the canoe.

### Craft construction process

The layout for the round bottom canoe mould was drawn on 2 sheets of plywood maintaining the required sizes and shape of each part that needed to be put together to make the complete hull. A zig-zag pattern was drawn on one part of the arranged plywood, tapering systematically from one end to the other, on both sides. This was achieved by using a long wooden batten to aid marking of proper straight lines with a HB pencil. The parts marked out on the plywood divided the plywood into two halves.

The marked plywood was placed on a work table, then a jig saw was used to saw along the marked zig-zag pattern from one end to the other end. The two pieces of plywood: two halves, were separated, then the pieces were swapped, and straight edges of the strips were joined to the edges of the second plywood using glue, piece of 6mm ply and wire nails.

The single strip after joining was folded gradually from the two sides to the centre, and then the sliced pieces at the two ends were bound together with binding wire.

24mm hard wood was fixed along the sides to form rigid gunwale of the canoe hull.

The construction process adopted is in line with that of (ACI, 1987). On the mould, polythene sheet was spread covering the outer surface to prevent sticking. 18mm and 6mm iron rod were placed, bent and binded with 2mm binding wire at the required positions to form the main frame work. 12mm wire mesh reinforcement was spread, stretched and binded to the rod reinforcement of the framework.

A mixture of cement sand ratio 1:2 was used to prepare a mortar through addition of water and thorough mixing. The mortar was carefully plastered into the rod and mesh network with the aid of the masonry trowel. The construction was allowed to set for 24hours before wetting commenced. Jute sac material was sliced and used to cover the hull then water was applied at 6 hours interval. After curing for a period of 3 weeks, the hull was removed from the mould and turned over. Water that has weight equal to the boat was poured into the canoe to determine floating level. A portable grinding machine was used to grind the rough surfaces of the hull to make it smooth, then 3 coats of oil gloss paint was used to paint the entire hull.

### Testing, assessment and determination of specifications of the canoe

After the construction, the completed canoe (plate2.) was conveyed from the college (FCFFT, New Bussa) boat building workshop to 'Kigera III' reservoir for testing with the aid of a simple boat trailer. It was gently placed on water then allowed to float empty, while being observed for leakage, stability, and draft. The capacity was tested practically by allowing one person at a time, until it carries the maximum weight it could carry to float at the maximum displacement float plane, in line with Maritime and coast Guard (2003). The canoe was also conveyed to Kainji Lake, and then tested for the effect of wave and lake turbulence alongside a local canoe of same size. The testing was carried out by propelling the canoes (through manpower effort), from Tada fishing village (9°53'N 4°33' 55.7E) to Yunna fishing Village (9°54' 27.23'N 4°33' 42.28'E).

The design specifications of the canoe obtained from the design sketch were compared with the canoe's specifications obtained through direct measurement after construction. The magnitude of the draft was obtained through direct measurement of the part of the boat bellow water line, in line with Maritime and Coastguard Agency (MCA) (2009). The stability status was also obtained through roll or heel test guideline of MCA (2009).

The total cost of producing the ferrocement canoe, was obtained based on the local market price of the materials used (Abubakaret al.,2011). It was compared

with the cost of local canoe of equal size that is commonly used through simple economic analysis.

## RESULTS AND DISCUSSION

The design data obtained from the free hand sketch, shows that the data for sections are the same; the data for sections 2 and 4 are also similar, while section 3 has a different data from other sections. The design lines that constituted the main sketch and the projected sections indicated that there are 5 sectional lines and 6 horizontal curved lines. The body plan projections indicate that section 1 and 5 are identical in both shape and size while; Section 2 is same as section 4 and section 3 is the midship section. Table 1 shows the list of materials and scantling sizes. The plan and profile views of the canoe (fig 1), indicates the top view which is symmetrical and the profile view indicates the side view respectively. (fig 2) indicate the design layout and the cutting pattern on the plywood. Plate 1 shows: Cured canoe hull removed from the mould construction of the canoe mould, while Plate 2 shows the canoe with 3 persons on board.

The result of the determination of specifications, shows that the length overall (LOA) was 4.7M, beam overall (BOA) is 0.98 M, and depth is 0.30 M. The light displacements were 0.26tonnes (T). The result of the light displacement by estimation was (0.4667T) (466.7kg), and the Capacity was calculated to be 0.375tonnes (T). Water plane area was 2.085m<sup>2</sup>. The water plane area coefficients were 0.72 and the block coefficient was 0.58. The displacement and TPC was 0.635 and 0.021 (T).

When the completed canoe was placed on water (empty), it floated at a shallow draft of 17cm with stable equilibrium, whereas the draft was 25cm while carrying five persons. The canoe carried a maximum of 5 persons (with an average weight of 70kg); hence the capacity based on this was 0.59 Tones.

The stability check based on roll period, indicated that the period of roll of the improved canoe (0.80s) was less than the beam of the canoe (0.84m). This indicates that the canoe was stiff (stable). Hence, the period of roll for the local canoe (1.1s) was more than the beam of the canoe (0.77m). This indicates that the canoe is tender (not stable). When the improved canoe was observed for leakages visually, there were no signs of water on the floor and the parts below water line.

The list of construction materials and scantling sizes cost for the improved canoe presented in table 1, indicates that the total sum of N51,500 was used to purchase the materials used from the local market. Greater part of the cost was on the purchase of the iron reinforcement used for the major construction work. The cost of local canoe of same size around Kainji lake area was recorded to be within the range of N 38,000 to N46, 000 depending on the quality of materials used for the construction.

The result of the benefit cost ratio calculation indicated that at discount value of 10% the benefit over a period of 15 years (N3,327,659.79) was greater than the discounted value of cost (N 391,713.10) with resultant ratio of 8.48:1.

## CONCLUSION AND RECOMMENDATIONS

The fishing craft, despite the weight, has least cost, adequate stability and easy maneuverability as its attributes. These important qualities are adequate for a craft needed for artisanal fishing activities. The ferrocement canoe was observed to have adequate water tightness and proper reinforcement. This made the canoe more efficient for fishing as the fishermen would not have to spend part of their fishing time bailing out water as obtained in the local canoe, and the improved canoe is also safer for use due to adequate reinforcement, there is less tendency of the canoe braking into pieces leading to loss of lives and catches, which is a common phenomenon in the use of the local canoes. The overall result of the assessment of the improved canoe for hydrostatic characteristics, performance on turbulent water and economic analysis were generally adequate for a craft that is needed for the improvement of artisanal fishing activities in Kainji Lake basin.

It is recommended that the improved canoe is introduced to the artisanal fishermen fishing on the lakes and other large inland water bodies in Nigeria as a replacement of the flat bottom canoes in use. This is in order to immediately address the loss of lives through accidents and also save the fishermen from spending their resources on crafts that are not safe and durable. This craft is also recommended for use on turbulent inland water bodies such as Kainji Lake, hence it can be introduced to fishermen operating on calm water bodies as a replacement of the locally built canoes that are characterized by short lifespan and high maintenance cost. Hence, same technology should be introduced to local boat builders to construct larger craft for transportation and fishing on Kainji Lake.

## ACKNOWLEDGEMENTS

I wish to thank Almighty God for sparing my life, giving me the strength and ability to carry out this work successfully and for all other blessings bestowed on me. My profound gratitude goes to my office (Federal college of freshwater fisheries technology New Bussa) for making all things possible for me to achieve this goal. I am highly indebted to my supervisors in persons of; Professor R.J Kolo and professor S.O.E Sadiku, for taking time despite their tight schedule to read through, criticize, correct and ensure that this work was successful. My unalloyed appreciations go to ICAAT for organizing the conference, and to Mr. Sanusi Abubakar, Mr. Mohammed Shaba for their untiring efforts, without which the success of the work wouldn't

have been possible. I finally wish to thank all the members of my family for their patience, endurance and support.





Table 1: Scantling sizes and cost estimate

Material	Size	Quantity	Unit	Amount N
Plywood	6mm	2sht	3500	7000
Glue	1kg	1tn	1200	1200
Wire nail	3/4 ''	1ib	300	300
Iron rod	6mm	8No	850	6800
Iron rod	10mm	6No	1800	10800
Wire mesh	12mm	6yds	350	2100
Binding wire	2mmroll	10rl	200	2000
Portland cement	50kg	2.bg	2650	5300
Sharp sand		200 kg		2000
Grinding disc	10mm	4	250	1000
Sanding	3mm	2	250	500
Labour cost				10,000.00
<b>Total cost</b>				<b>N51,500.00</b>

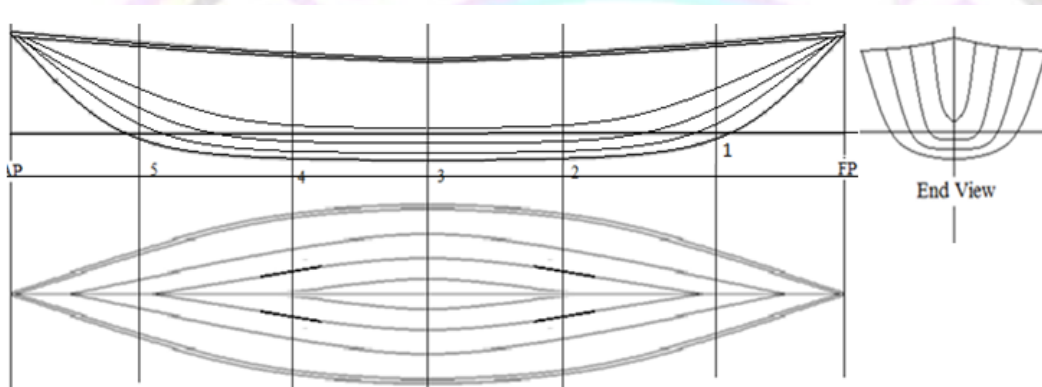


Fig 1: Design

sketch and body plan of the improved canoe

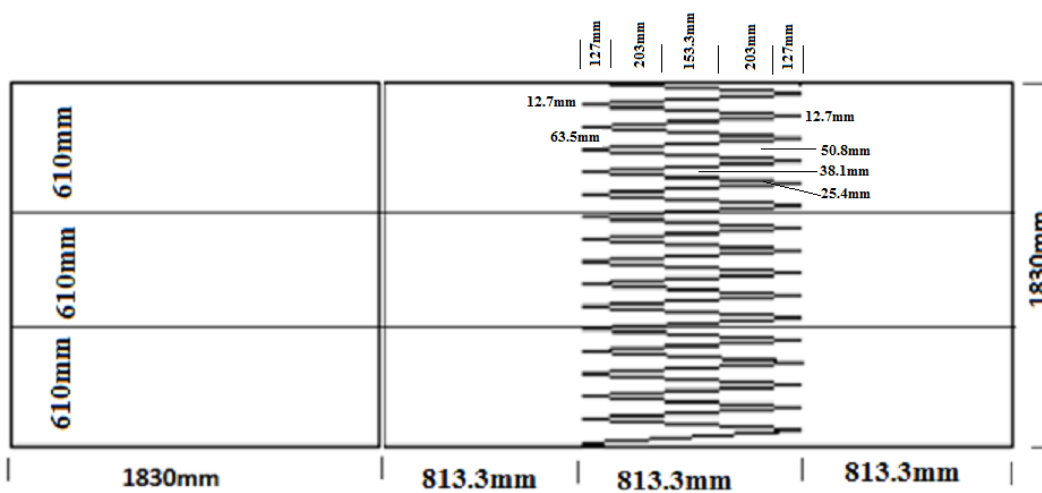


Fig. 2:

Design layout



**Plate 1: Cured canoe hull removed from the mould**



**Plate2: the canoe with 3 persons on board**

## REFERENCES

- Abubakar, S. (2006). Design and construction of an improved Flat bottom fishing Canoe. In: U.I Enin *etal* ( eds.) *Proceeding of the 21<sup>st</sup> Annual Conference of the fisheries Society of Nigeria*, Calabar 13<sup>th</sup> – 17<sup>th</sup> November, 2006 pp 335 – 347.
- Abubakar. S., Adamu. R., Ahmed. Y.B., Fajingbesi. O., Adeleye A. R. And Francis . A. (2011).Development of an improved Dug canoe for Artisanal Fishery.*Paper presented at the 26<sup>th</sup> Annual Conference of the fisheries Society of Nigeria, Minna 28<sup>th</sup> Nov. – 2<sup>nd</sup> Dec., 2011.*
- American Concrete Institute,(ACI) Farmington Hills, Michigan, 1997, 26 pages. Guide for the Design, Construction, and Repair of Ferrocement, ACI 549-1R-88 and 1R-93, in Manual of Concrete Practice, American Concrete Institute, Farmington Hills, Michigan, 1988 and 1993, 27 pages.
- Maritime Coast guard (2003), Safe loading. *Boatbuilder's Handbook revised ed. 2003*, the Aquatic Resources (Wallop-Breaux) Trust Fund, U.S Coast Guard. 54p.
- Love G. (1979) *The theory and practice of woodwork*. Longman publishers ,London, 4<sup>th</sup> ed. 56p.
- Maritime Coastguard Agency (2009) Procedure for carrying out a Roll or Heel test to assess stability for fishing Vessel Owners and Skippers. *Maritime and Coastguard Agency, Marine Guidance Note 2009; 7p.*
- National Research Council (1988) Fisheries technology for developing Countries *Report of an ad-hoc panel of the board for science and technology for international development* National Research. Council Washington DC.168p
- Ogundiwin D. I, (2014). Survey of Artisanal Fishing Gear and Craft: A case study of Kainji Lake lower basin, Nigeria. *Master Thesis in International Fisheries Management* Faculty of Bioscience, Fisheries and Economics University of Norway. 87p
- Riley R.O.N. and J. M.M. Turner (1995). Building ferrocement fishing boat, Fishingboat construction:3, FAO fisheries Technical Paper No:354

## RESPONSE OF COWPEA (*Vigna unguiculata* L. Walp) TO APPLICATION OF STARTER NITROGEN IN MINNA, NIGERIA

Afolabi\*, S.G., Adeboye, M.K.A. and Ohiare, N.M.

Department of Soil Science and Land Management.

School of Agriculture and Agricultural Technology, Federal University of Technology, P.M.B. 65, Minna, Niger State, Nigeria.

\*Corresponding Author e-mail: [afolabi.gbolahan@futminna.edu.ng](mailto:afolabi.gbolahan@futminna.edu.ng); [ooreoluwa14@gmail.com](mailto:ooreoluwa14@gmail.com)

GSM No. +2348035014309

### ABSTRACT

The experiment was conducted in the screen house of Federal University of Technology Minna, Nigeria, to determine the response of cowpea to application of starter nitrogen (N) in Minna. The treatments were 0, 10, 20 and 30 kg N ha<sup>-1</sup> laid down in a Completely Randomized Design (CRD) with four replications. Data collected were plant height, number of leaves, number of days to flowering, number of days to podding, grain yield and haulms yield. The results showed that the soil was sandy loam, low in organic carbon and phosphorous. At 4, 8, and 10 WAS, application of 30 kg N ha<sup>-1</sup> had significantly taller plant than control, but statistically similar to 10 and 20 kg N ha<sup>-1</sup>. The 10 kg N ha<sup>-1</sup> the highest grain yield and fresh haulms yield which were significantly higher than control. There was no significant effect of N on the soil chemical properties, except for total nitrogen were application of N resulted in significant increase over that of control. N application increased the growth and yield of cowpea, application of 10 kg N ha<sup>-1</sup> improved the growth parameters, haulms and grain yield of cowpea assessed.

**KEYWORDS:** Cowpea, starter nitrogen and Minna

### INTRODUCTION

Cowpea (*Vigna unguiculata* L. Walp) is an important grain legume usually grown in the dry savanna of tropical Africa, Asia and South America with over 9.3 million metric tons of annual production (Ortiz, 1998). Nigeria is the world's largest producer with about 2.1 million tons followed by Niger with 650,000 tones and Mali with 110,000 tones. FAO (2006) reported that 850 million people in the world with high incidence of undernourishment in sub-Saharan Africa. Cowpea is mostly intercropped with other crops such as millet, sorghum, pigeon peas, leafy vegetables, bananas, maize and others (Bittenbender *et al.*, 1984; Singh *et al.*, 1997). In intercropping system, the spreading indeterminate type of cowpea serves as a ground cover crop which helps in suppressing weeds as well as protects the soil against erosion and in addition, some varieties are suicidal germination of the seed of *Striga hermonthica*, a parasite plant that usually infests cereals with devastating effect (Quin, 1997). Cowpea grain is a rich source of protein, and its haulms, a valuable source of livestock protein (Fatokun, 2002). Both grain and leaves are edible products of cowpea that are rich in protein and cheap sources of protein.

On average, cowpea grain contains 23-25 % protein, cooked leaves contain two-third the protein, seven times the calcium, three times the iron, half the phosphorus, eight times the riboflavin, five times the niacin and several hundred times the ascorbic acid and beta-carotene of the cooked seed (Bittenbender, 1990). Cowpea yield are among the lowest in the world, averaging 310 kg/ha (Ofosun-Budu *et al.*, 2007). Consequently, efforts have been made to improve cowpea production in Nigeria through various means including the introduction of new varieties (Addo-Quaye *et al.*, 2011). None of these improved varieties could achieve optimum yield without appropriate fertilizer recommendation. The positive effect on the application of inorganic fertilizer on crop yield and yield improvement has been reported (Carsky and Iwuafor, 1999).

Nitrogen (N) is the most important element needed for crop production. Although, cowpea symbiotically fixes N, plants which are dependent on symbiotically fixed N may suffer from temporary N-fixation during the seedling growth once the cotyledon reserves have been exhausted. It has thus been recognized and demonstrated that application of a small amount of nitrogen fertilizer enhances early vegetative growth (Dart *et al.*,



1977). Nitrogen fertilizer is sometimes also used as a starter dose. Cowpea responds to added fertilizer despite its capacity to fix nitrogen with *Rhizobium* (Sultana, 2003). Although there are divergent views of nitrogen application to legumes, especially cowpea, results of investigation in the tropics have indicated either no response or significant response to nitrogen fertilizer application (Akinola, 1978). It has also been reported that available nitrogenous compound allowed seedlings to make a good start before nitrogen fixation has a chance to occur. Other researchers have shown that plants given inorganic N during vegetative periods were much larger by the onset of flowering than those dependent on symbiotic N fixation (Minchin *et al.*, 1981). Such plants also had more branches and produced many peduncles resulting in greater number of pods, seeds and significantly larger yields.

Despite the importance of cowpea in human diet and animal feed, the yield obtained by most farmers in Nigeria is very low due to the rapid increase in population, there is need to increase production generally and that of cowpea in particular hence the objective of the study is to evaluate the response of cowpea to application of starter N in Minna.

## **MATERIALS AND METHODS**

### **Study site**

The experiment was conducted at screen house, Federal University of Technology, Gidan Kwano, Minna, Niger State in the Southern Guinea Savanna of Nigeria. Climate of Minna is sub-humid with mean annual rainfall of about 1284 mm. The physical features around Minna consist of gently undulating high plains developed on basement complex rocks made up of granites, migmatites, gneisses and schists. Inselbergs of "Older Granites" and low hills of schists rise conspicuously above the plains. Beneath the plains, bedrock is deeply weathered and constitutes the major soil parent material. The soil has been classified as Typic plinthustalf (Lawal *et al.*, 2012)

### **Treatments and experimental design**

The treatments consisted of four rates of N, application 0, 10, 20, 30 kg N ha<sup>-1</sup>. The experiment was laid out in a completely randomized design (CRD) with four replications to give a total of 16 pots.

### **Soil sampling and analysis**

Surface soil (0-15 cm) collected from the Teaching and Research Farm of the Federal University of Technology, from different points were bulked together to give a composite sample. The soil samples were analysed according to the procedures described by Agbenin (1995). Particle size analysis was carried out by Bouyoucos hydrometer method and textural class, determined using the textural triangle. The soil pH was measured in 1:2.5 soil/CaCl<sub>2</sub> suspension with glass electrode pH meter and organic carbon by Walkley-Black method. Available phosphorus (P) was extracted by Bray P1s method. The phosphorus concentration in the extract was determined colorimetrically using the spectrophotometer. Exchangeable acidity was determined by titrimetric titration with standard NaOH. Exchangeable bases, Ca<sup>2+</sup>, Mg<sup>2+</sup>, K<sup>+</sup> and Na<sup>+</sup> were extracted with 1N NH<sub>4</sub>OAc. Ca<sup>2+</sup> and Mg<sup>2+</sup> in the extracts were determined using atomic absorption spectrophotometer (AAS) while K<sup>+</sup> and Na<sup>+</sup> by determined by flame photometer.

### **Agronomic practices**

Three seed of cowpea variety Sampea 15 (IT99K-573-2-1) was sown in the pot. Two weeks after sowing (WAS), the cowpea plant was thinned to one plant per pot. 10 kg/ha of phosphorous and potassium was applied at 2 WAS as basal application. Nitrogen fertilizer was applied at 2 WAS. The source of phosphorous and potassium were single super phosphate and muriate of potash respectively while urea was used to supply nitrogen and the fertilizer was applied by ring method. Weeding was also done on a weekly basis by hand pulling.

### **Growth and yield components**

The plant height of cowpea was measured from the base of the plant to the tip of the plant using meter rule at 2, 4, 6, 8 and 10 WAS. Number of leaf was determined by numerical counting of leaves on each plant at 2, 4, 6, 8 and 10 WAS. Number of days to flowering was calculated from the date of sowing to the date when the first flower appeared on each treatment pot and recorded as days to flowering. Plants were harvested 8 WAS. Shoots were cut down at soil level, roots were washed, nodules were collected, counted, weighed and recorded as fresh nodule weight. Dry nodules weight was weighed and recorded as dry nodules weight. Biomass fresh weight and dry biomass weight were weighed and recorded.

### **Statistical analysis**

Data collected were subjected to Analysis of Variance (ANOVA) using the General Linear Model Procedure of Statistical Analysis System (SAS

version 9.0) 2002. Treatment means were compared using least significant difference (LSD) at 5 % Level of probability.

## RESULTS AND DISCUSSION

The soil physical and chemical properties before sowing are shown in Table 1. The textural class of the soil was sandy loam. The soil was slightly acidic in water (pH 6.5) and the organic carbon ( $3.12 \text{ g kg}^{-1}$ ), with available phosphorus ( $9 \text{ mg kg}^{-1}$ ) was low and high N ( $0.58 \text{ g kg}^{-1}$ ) content (Esu, 1991). The effect of N on some soil chemical properties is shown in Table 2. There was no significant effect of N on the soil chemical properties, except for total nitrogen where application of N resulted in significant increase over that of control.

The effect of nitrogen on plant height of cowpea at different growth stage is shown in Table 3. At 2 WAS, all the pots with starter N were significantly taller ( $p < 0.05$ ) than the control. At 4, 8, and 10 WAS, the treatment  $30 \text{ kg N ha}^{-1}$  had significantly taller plant than control, but statistically similar to 10 and  $20 \text{ kg N ha}^{-1}$ . The effect of starter N on number of leaves are shown in Table 4. The control had significantly higher number of leaves than other treatments at all the growth stages of the plant except at 2 WAS. There was however no significant difference amongst the other treatments at all the growth stages of the plant. The effect of N on yield components of cowpea are shown in Table 5. Application of starter N had no effect on flowering and podding of the plant. All the plants flowered and podded at the same time. Similarly, all the plants produced the statistically similar number of pods. Effect of N on grain yield of cowpea was shown in Figure 1. The treatment  $10 \text{ kg N ha}^{-1}$  recorded the highest grain yield and the lowest was observed in  $0 \text{ kg N ha}^{-1}$ .

The pH of the soil which was slightly acidic and favourable for accessibility of plant nutrients as most plant nutrients are available for plant uptake at pH 5.5- 6.5 (Brady and Weil, 2002). The N content of the soil is high probably due to prior cultivation of land with fertilizer or incorporation of crop residue. Giller (2001) reported that N increases the growth of plant. The reduction of flowering and podding duration was observed, this might be due to enhanced supply of carbohydrate to active reproductive parts (Giller *et al.*, 1991). Afolabi *et al.*, (2013) observed an increase in plant height, shoot biomass, leaf number as result of application of nitrogenous fertilizer with phosphate fertilizer. Sultana (2003)

also reported that plant height increased due to increase in N fertilizer.

Nitrogen application increases yield of cowpea. This increase might be due to the positive effect of N element on plant growth that lead to progressive increase in internodes length and consequently plant height. Several reports had earlier attributed significant increase in the development of vegetative plant parts and dry matter accumulation with N application, as N is an important constituent of chlorophyll, amino acid and nucleic acid (Anjorin, 2013). The improvement in plant growth also corroborated the findings of Cox *et al.*, (1993); Sumi and Ketayama, (2000) also reported that N promotes higher leaf area development and reduced rate of senescence. The application of N increased the grain yield of cowpea. This is in agreement with the findings of Minchin *et al.* (1981) who showed that cowpea plants supplied with nitrogen fertilizer had more branches, produced many peduncels and so greater number of pods, seeds, and significantly larger grain yields than those dependant on symbiotic nitrogen fixation.

## CONCLUSION AND RECOMMENDATIONS

From the result of this study, N application increased the plant height, haulms and grain yield of cowpea. Application of  $10 \text{ kg N ha}^{-1}$  improved the growth parameters, haulms and grain yield of cowpea, suggesting that application of  $10 \text{ kg N ha}^{-1}$  will improve the performance of cowpea assessed. A field trial should be conducted to ascertain this finding.

**Table 1: Physical and chemical properties of the soil used for the experiment**

Parameters	Values
Sand (g kg <sup>-1</sup> )	858
Silt (g kg <sup>-1</sup> )	40
Clay (g kg <sup>-1</sup> )	102
Textural class	Sandy loam
pH in water at 1:2.5	6.5
Organic Carbon (g kg <sup>-1</sup> )	3.12
Total Nitrogen (g kg <sup>-1</sup> )	0.58
Available phosphorus (mg kg <sup>-1</sup> )	9
Exchangeable Bases (cmol kg <sup>-1</sup> )	
Ca <sup>2+</sup>	4.12
Mg <sup>2+</sup>	1.00
K <sup>+</sup>	0.09
Na <sup>+</sup>	0.16
Exchangeable acidity (cmol kg <sup>-1</sup> )	0.02
ECEC	5.39

**Table 2: Effect of nitrogen fertilization on some soil chemical properties**

Treatment (kgN/ha)	EK (cmol kg <sup>-1</sup> )	AP (mg kg <sup>-1</sup> )	OC (g kg <sup>-1</sup> )	TN (g kg <sup>-1</sup> )
0	0.06	5.23	9.73	0.50
10	0.06	5.53	10.40	0.66
20	0.07	5.14	6.40	0.80
30	0.06	4.74	8.00	0.55
LSD	0.009	0.45	2.13	0.14

EK: Exchangeable potassium AP: Available phosphorus OC: Organic Carbon TN: Total Nitrogen

**Table 3: Effect of nitrogen on plant height**

Treatment (kg N ha <sup>-1</sup> )	Plant height (cm)				
	2 WAS	4 WAS	6 WAS	8 WAS	10 WAS
0	18.2	24.2	31.0	33.6	33.6
10	27.3	29.1	38.0	40.2	40.3
20	25.4	30.6	37.3	40.2	40.2
30	26.2	31.1	45.1	41.8	41.8
LSD	3.81	3.15	6.67	4.49	4.83



WAS: weeks after sowing

**Table 4: Effect of nitrogen on number of leaves**

Treatment (kg N ha <sup>-1</sup> )	Number of leaves				
	2 WAS	4WAS	6WAS	8WAS	10WAS
0	7	20	26	36	37
10	11	15	21	22	24
20	8	13	17	20	22
30	9	14	19	23	23
LSD	2.19	4.43	3.93	7.30	7.13

WAS: weeks after sowing

**Table 5: Effect of nitrogen on yield components**

Treatment (kg N ha <sup>-1</sup> )	DTF	DTP	NPPP	FHY	DHY
0	46	58	2	8.59	3.36
10	47	59	3	16.77	5.08
20	44	62	3	10.78	3.46
30	51	56	3	14.95	4.03
LSD	3.57	2.56	0.54	3.89	0.85

DTF: Days to flowering, DTP: Days to podding, NPPP: Number of pods per plant  
 FHY: Fresh haulms yield DHY: Dry haulms yield

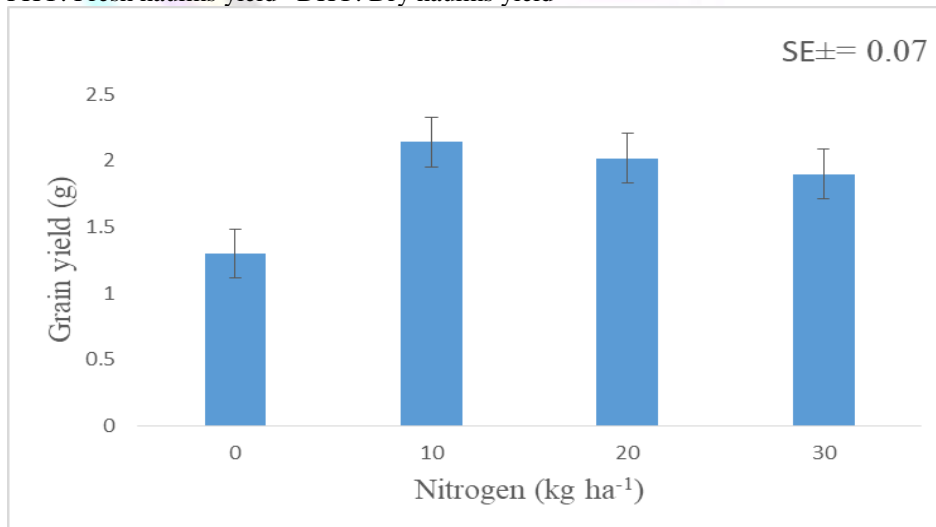


Figure1: Effect of nitrogen on grain yield

## REFERENCES

- Addo-Quaye A.A., Darkwa A.A., and Ampian, M.K.P. (2011). Performance of three cowpea (*Vigna unguiculata* [L.]Walp) varieties in two agro-ecological zones of the Central Region of Ghana II: Grain yields and its components. *ARP Journal of Agricultural and Biological Science*. 6 (2): 1-9.
- Afolabi, S.G., Ogunsesan, A.O., Uzoma, A.O., Adeboye, M.K.A., Bala, A. and Osunde, A.O. (2013). Growth, nodulation and yield response of cowpea to fertilizer inputs on Alfisols in Minna, southern Guinea savanna of Nigeria .Ojeniyi, S.O. Agbede, O.O. and Jayeoba, O.J. (eds.) *Soil Science, Environmental Management and food security. Proceedings of the 37<sup>th</sup> Annual Conference of the Soil Science Society of Nigeria*. pp 159-165.
- Agbenin, J.O. (1995). *Laboratory Manual for Soil and Plant Analysis. (Selected Methods and Data Analysis)*. Published by the author. 140pp.
- Akinola A.A. (1978). Influence of soil organic matter on cowpea: Response to N fertilizer. *American Journal Agronomy*. 70(1): 25.
- Anjorin, F.B.(2013). Comparative growth and grain yield response of five maize varieties to nitrogen fertilizer application. *Greener journal of Agricultural sciences*. 3(12): 801-808.
- Bittenbender, H.C. (1990). Handling and storage of cowpea (*Vigna unguiculata*(L.) Walp.) as a leaf vegetable. *Tropical Agriculture*. 69:197-200.
- Bittenbender, H.C., Barrett, R.P. and Indire-Lavusa, B.M. (1984). *Beans and cowpea as leaf vegetables and grain legumes*. Occasional Monograph Series, No. 1, Bean/Cowpea CRSP, Michigan State University, East Lansing, MI, USA 34. Pp. 1-21.
- Brady, N.C. and Weil, R. (2002). *The Nature and Properties of Soils*. 13<sup>th</sup> edition. Singapore, Pearson Education. 976pp.
- Carsky R.J. and Iwuafor E.N.O (1999). Contribution of Soil Fertility Research and Maintenance to Improve Maize Production and Productivity in Sub-Saharan African. In: *Strategy for Sustainable Maize Production in West and Central Africa*, Badu-Apraku, B., M.A.B. Fakorede, M. Ouedraogo and F.M. Quin (Eds.). International Institute for Tropical Agriculture, Cotonou, Benin Republic, pp: 3-20.
- Cox, W.J., Kalonoge, S., Cherney, D.J.R., and Raid, W.S. (1993). Growth yield and quality of forage maize under different nitrogen management practice. *Agronomy journal*. 85: 341-347.
- Dart, P., Day, J., Islam, R.A. and Dobereiner J.(1977). Some Effects of Temperature and Composition of the Rooting Medium in Symbiotic Nitrogen Fixation in Plants Synthesis. In: *Tropical Grain Legume, Nutman, R.S. (Ed.)*. Cambridge University Press, pp: 361-383.
- Esu I.E. (1991). Detailed soil survey of NIHORT Farm at Bunkure, Kano state, Nigeria. Institute for Agricultural Research, Ahmadu Bello University, Zaria, Nigeria. 72pp.
- FAO (Food and Agriculture Organisation of the United Nations), 2006. *The state of food and agriculture: Food aid for food security?*
- Fatokun A.C.(2002). Breeding Cowpea for Resistance to Insects Pests, Attempted Crosses Between Cowpea and *Vignavexillata*. In: *Challenges and Opportunities for Enhancing Sustainable Cowpea Production*, Fatokun, C.A., S.A. Tarawali, B.B. Singh, P.M. Kormawa and M. Tamo (Eds.). *International Institute for Tropical Agriculture (IITA) Ibadan, Nigeria*, pp: 52-61.
- Giller K.E. (2001). *Nitrogen fixation in tropical cropping systems*. CABI Publishing, Wallingford, UK. 423pp.
- Giller, K.E., Ormesher, J and Awah, F.M. (1991). Nitrogen transfer from phaseolus bean to intercropped maize measure using <sup>15</sup>N-

- enrichment and  $^{15}\text{N}$ - isotopes dilution methods. *Soil Biology and Biochemistry*. 23: 339-346.
- Lawal, B.A., Adeboye, M.K.A., Tsado. P.A., Elebiyo, M.G. and Nwajoku, C.R. (2012). "Properties, classification and agricultural potentials of lateritic soils in Minna in sub-humid agroecological zone, Nigeria", *International Journal of Development and Sustainability*. 1 (3): 903-911.
- Minchin, F.R., Summerfield, R.J. and Neves, M.C. (1981). Nitrogen nutrition of cowpea (*Vigna unguiculata* (L.), Walp): Effects of timing of inorganic nitrogen application. *Tropical Agriculture. (Trinidad)*. 58: 1-12.
- Ofosu-Budu K.G., Obeng-Ofori D., Afreh-Nuamah K. and Annobil R. (2007). Effect of phosphorus-compost on growth and yield of cowpea (*Vigna unguiculata*). *Ghana Journal Agricultural Science*. 40: 169-176.
- Ortiz, R. (1998). Cowpeas from Nigeria: A silent food revolution. *Outlook Agriculture*. 27: 125-128.
- Quin, F.M. (1997). Introduction. In: B.B. Singh, D.R. Mohan Raj, K.E. Dashiell and L.E.N. Jackai (eds.). *Advances in cowpea research*. Co-publication of International Institute of Tropical Agriculture (IITA) and Japan International Research Center for Agricultural Sciences (JIRCAS). Ibadan, Nigeria.
- Singh, B.B., Chambliss, O.L. and Sharma, B. (1997). Recent advances in cowpea. In: B.B. Singh, D.R. Mohan Raj, K.E. Dashiell and L.E.N. Jackai (eds.). *Advances in cowpea research*. Co-publication of International Institute of Tropical Agriculture (IITA) and Japan International Research Center for Agricultural Sciences (JIRCAS), Ibadan, Nigeria. Pp. 30-49.
- Sultana, M.N. (2003). Effects of Rhizobium inoculum and nitrogen fertilizer on yield and nutrient quality of cowpea (*Vigna unguiculata*) forage at different stages of maturity. M.Sc. (A.H). Thesis, Dept. of Animal Nutrition, Bangladesh Agricultural University, Mymensingh.
- Sumi, A. and Ketayama, T.C. (2000). Effect of nitrogen fertilizer application and solar on the growth response of sorghum seedling to soil moisture. *Crop Science*. 69: 513-519.



# MEAT QUALITY AND SENSORY PROPERTIES OF BROILER CHICKENS FED COMMERCIAL DIETS

Shadawo. Y.J., Jiya, E. Z., Kudu, Y.S. and Adigun, U.O.

Department of Animal Production, Federal University of Technology, Minna, Niger State, Nigeria

**Corresponding Author:** Email: Shadawofaith@gmail.com G.S.M: 08130000002

## ABSTRACT

*A total of one hundred and eighty (180) unsexed day old broiler chickens (cobb ® 500) were used to evaluate the meat quality and sensory properties of broiler chicken fed commercial diets. The birds were obtained from Olam Feed and Hatchery Mill. Located at Chikpiri village, Chikun LGA, Km 25 kaduna – Abuja expressway Kaduna, Nigeria. The birds were randomly allocated to five treatments, each treatment having three replicates and twelve (12) birds per replicate. The birds were fed a control diet and four different commercial diets ad libitum. The experiment was completely randomized design (CRD) and lasted for six weeks. The birds were intensively managed on deep litter system. At the end of growth studies one bird per replicate was sacrificed and the meat from breast of chicken was used for the analysis. Data was collected on meat quality characteristics; pH, WHC, cooking yield, cooking loss and carcass composition. Sensory properties were also evaluated. The result revealed that all the meat quality characteristics were significantly ( $p < 0.05$ ) different among the treatment means. The carcass composition except ash were also significantly ( $p < 0.05$ ) different among the treatment means. The sensory properties were not significantly ( $p < 0.05$ ) influenced by the treatments for all the parameter measured except overall acceptability which was significantly ( $p < 0.05$ ) different. It was concluded that commercial feeds compare well with the control in terms of meat quality characteristics and sensory properties.*

**Keywords:** Meat quality, Sensory Evaluation, Commercial diets.

## INTRODUCTION

Meat is one of the most important foods in the world (Amaefule and Obioha, 2001; Delgado, 2003). Its quality is very important for both consumers and producers and it depends on different factors. In order to produce high quality meat, it is necessary to understand the characteristics of meat quality traits and factors (Joo *et al.*, 2013). Toldrá (2006) considered that such aspects of meat as source, cost, ethical factors, religion, production systems and safety, influence on the acceptability of the product by consumers.

Other quality factors perceived by consumers are related to sensory characteristics (for example colour, tenderness and flavour), nutritional properties (for example calories, vitamins content, fatty acids profile, and soon) and appearance (for example exudation, marbling, visible amount of fat, and soon) (Toldrá, 2006). Important quality traits for fresh meat are colour, water-holding capacity, texture and amount of fat, while the important traits for eating quality of cooked meat are tenderness, flavour and juiciness (Joo *et al.*, 2013).

Water holding capacity (WHC) is among the most important functional properties of raw meat (Jauregui *et al.*, 1981). The authors proposed the use of the terms water binding potential, expressible juice and free drip to categorize the WHC of meat samples. Water binding potential (WBP) was defined as the ability of the muscle proteins to retain water in excess and under the influence of external forces. Factors such as pH, macromere length, ionic strength, osmotic pressure, and development of rigor mortis influence the WHC by altering the cellular and extracellular components (Northcutt *et al.*, 1994; Offer and Knight, 1988). Tenderness, juiciness, firmness, and appearance of meat improve as the content of water in the muscle increases, leading to an improvement in quality and economical value.

The appearance of meat deals with the visual identification of quality meat based on color, marbling, and water holding capacity. The meat should have a normal color that is uniform throughout. In addition, it should have marbling throughout the cut. Meat quality is a term used to describe a range of attributes of meat (Ani and Okeke, 2011). Appearance, texture, juiciness, wateriness, firmness, tenderness, odor and flavour are

the most important and perceptible meat features that influence the initial and after purchasing a meat product. It is important to remember that feed companies are very much in the business of making money. Just like in the human food industry there are thousands of clever new products in the market. The fact is that most, if not all, of the feed on the commercial market may not contain the required nutrient for production. Feed is the most important input for poultry production and the availability of low-priced, high-quality feeds is critical for the expansion of the poultry industry and quality (FAO, 2003). The assessment of meat products from commercial feeds is not ascertained, therefore the aim of this was to evaluate the meat quality and sensory properties of broiler chicken fed commercial diets.

## METHODOLOGY

The research work was carried out at the Poultry production unit Minna, Opposite Veterinary Hospital, Bosso, Minna, Niger State. Niger state lies between latitude 8° 00' and 11° 30' N and longitude 3° 20' and 7° 40' E.

A total of one hundred and eighty (180) day old broiler chickens (Cobb® 500) were bought from Olam Feed and Hatchery Mill. Located at Chikpiri village, Chikun LGA, Km 25 Kaduna – Abuja expressway Kaduna, Nigeria. The housing system was intensive (deep litter) with concrete floor, covered with wood shavings on it. The pen were cleaned and washed with water and detergents. The pen was disinfected with formaldehyde solution to get rid of harmful organisms a week prior to the arrival of the chickens. The birds on arrival were randomly allocated into five treatments with three replicates each, twelve (12) birds per replicate. The broiler chickens were fed a control diet and four different commercial diets (Table 1, 2 and 3). Fresh and clean water were given *ad-libitum*. A completely randomized design (CRD) was used for the research and the experiment lasted for six weeks.

### Meat quality characteristics of Broiler Chickens fed commercial diets

In determining the meat yield and meat quality characteristics of broiler chickens, the method of Jiya *et al.* (2014) was adopted. After the conclusion of the growth experiment, fifteen (15) broiler chickens were randomly selected from the five treatments, one broiler chicken from each replicate. Their final live weight was determined and recorded, then fasted overnight by allowing the animal access to water only; they were then slaughtered using a knife by

means of cutting through the jugular vein and carotid artery around the atlas bone. The broiler chicken was suspended with the head facing down-ward; this was done to allow for complete bleeding. The broiler chickens were dressed by complete removal of the feathers.

### pH of Broiler meat

A pH meter was used following the method of Marchiori and deFelicio (2003). 10g sample of meat was homogenized in 90 ml distilled water using a blending machine (model 242, Nakai, Japan) at speed 5. The pH meter was standardized by means of buffers 4 and 7, after which the pH reading of meat samples were taken.

### Water holding capacity (WHC)

Meat samples from the breast muscles were used to evaluate the WHC according to the methods described by Kauffman *et al.*, (1992). A 10g of the fresh/hot meat sample was taken using a digital sensitive weighing scale. The sample was laid between two filter papers and pressed in a screw jack to expel out the water/ fluid contained in it. The sample was then removed from the filter paper and weighed again. The difference between the initial and the final weights were the weight of the expelled water/fluid which is expressed as a percentage of the initial sample weight and recorded as the WHC.

### Cooking Yield of meat

Cooking yield of meat sample was determined according to method of Okubanjo (1997). The percentage of the last weight of cooked meat and first weight of raw meat were determined as shown below:

$$\text{Cooking yield (\%)} = \frac{\text{Weight of cooked meat sample}}{\text{Weight of raw meat sample}} \times 100$$

$$\text{Cooking loss} = \text{Initial meat weight} - \text{cooked meat weight}$$

### Proximate Composition

The proximate composition of breast meat samples were determined for moisture, crude protein, fat and ash using the method of AOAC (2000).

### Sensory evaluation from the Breast meat of Broiler chicken

Lean meat from the breast of the broiler chicken from each treatment group were used to evaluate the sensory attributes. Various cuts of the meat were made into bite size and boiled in water without salt at 80°C



for 15 minutes. The meat samples were left to cool to room temperature and then served in plates to a 30-member untrained taste panel selected from the University Community (Federal University of Technology, Minna). They were instructed to evaluate the meat for appearance, taste, juiciness, chewiness, texture, aroma and overall acceptability using a 9-point Hedonic scale (where 1 = dislike extremely and 9 = like extremely) as adopted by Vasanthakumar *et al.*, (1999). Panelist were served with cold water after each round of assessment of the meat sample to rinse their mouth to avoid carryover result of the preceding assessment.

### Statistical Analysis

Data obtained were subjected to analysis of variance (ANOVA) using SAS (2013). Where significant differences existed, means were separated by the method of Duncan (1955) at 5% level of significance.

## RESULTS AND DISCUSSION

Table 4 shows the result of meat quality characteristics of broilers fed commercial diets. The result revealed significant ( $p < 0.05$ ) differences in mean values of pH, water holding capacity, cooking yield and cooking loss. The pH had similar values in T<sub>2</sub> (6.09), T<sub>3</sub> (6.07), T<sub>5</sub> (6.06) and T<sub>4</sub> (5.90). The least was observed in the control (5.82). The control is similar the values recorded in T<sub>4</sub>. The water holding capacity of T<sub>3</sub> (42.00%) was highest compared to all other treatments that are similar. The result of cooking yield was higher in T<sub>5</sub> (75.80%) and it cooking loss was least in the same treatment (24.20%). pH values provides a good guideline for judging physiological meat quality. The pH range of 5.82 – 6.09 of this study is within the normal range and is classified as normal for quality purposes (Lara *et al.*, 2003). The significant ( $p < 0.05$ ) difference in WHC of meat from broiler chicken fed commercial diets compared to the control might not be a result of the feed but due to factors as metabolic state of the live animal at the time of harvest, genetic make-up or the way the animal was handled at the time of the harvest. Such reasons were corroborated by Kauffman *et al.*, (1992) and Omojola and Adesihinwa (2006). T<sub>5</sub> had higher cooking yield and of course a low cooking loss which is inversely proportional. The low loss (24.20%) reported in this study is lower than the (27.69%) reported by Omojola and Adesihinwa (2006). This is also dependent on the WHC of the meat.

The result of the carcass composition of broiler chicken fed commercial diets is presented on Table 5. The result showed that, moisture, crude protein and

fat percentages were significant ( $p < 0.05$ ) different among the treatment means. Only Ash percent was not significantly ( $p < 0.05$ ) influenced by the diets. The moisture content were significantly ( $p < 0.05$ ) in T<sub>3</sub> (65.62%), T<sub>4</sub> (65.54%) and T<sub>2</sub> (64.09%). The least was recorded in T<sub>5</sub> (61.24%) although similar to the control. Crude protein result followed a similar trend with those of the moisture content. Fat content revealed significant ( $p < 0.05$ ) difference among treatment having similar values in T<sub>1</sub> (2.39%), T<sub>3</sub> (2.16%), T<sub>4</sub> (2.14%) and T<sub>2</sub> (2.07%). The least values were observed in T<sub>5</sub> (1.87%). The significant ( $p < 0.05$ ) effect observed in the carcass composition might be as a result of the feed type. Feed in treatment five gave the least moisture (61.24%), crude protein (27.13%) and fat (1.87%). They are in line with those reported by Gumulka *et al.*, (2006); Gardzielewska *et al.*, (2009). The chemical composition of the respective muscles determines the nutritional value of the meat (Biesiada-Dizazga, 2008).

Sensory properties of broiler chicken fed commercial diets shown (Table 6) revealed no significant ( $p < 0.05$ ) differences in colour, juiciness, appearance, flavor, aroma and tenderness. However, overall acceptability was significant ( $p < 0.05$ ) differences among the treatment means. The highest acceptability was recorded in the meat of broiler chicken fed commercial diets T<sub>5</sub> (7.57) and the least was recorded in the control diets (6.47). The significant ( $p < 0.05$ ) effect on the overall acceptability of the meat from T<sub>5</sub> (7.57) might be as a result of the diet composition. Puvaca *et al.* (2015) published in their research that sensory quality of meat has high scores for small, juiciness and overall impression; it could that the feed millers may have added some spices to their feed.

## CONCLUSION AND RECOMMENDATIONS

It is therefore concluded that the type of feed tasted in the study provide good meat quality, fat composition and sensory acceptability at six weeks of age.



**Table 1: Composition of control diets (T<sub>1</sub>)**

Ingredient	Starter	Finisher
Maize	53.84	59.52
GNC	28.11	22.43
Bone meal	3.50	3.50
Salt	0.30	0.30
Methionine	0.20	0.20
Lysine	0.20	0.20
Premix	0.25	0.25
Maize bran	9.6	9.6
Fish meal	4.0	4.0
TOTAL	100	100

Supplied per Kg: 800 IU vitamin A; 1200 IU vitamin D<sub>3</sub>; 13mg vitamin E; 2mg vitamin K; 3mg riboflavin; 10mg cobalamin; 1.5mg folic acid; 0.25mg biotin; 125mg antioxidant (satoquin); 25mg Fe; 80mg Mn; 50mg Zn; 2mg Cu, 0.2mg Co; and 0.1mg Se.

**Table 2: Proximate composition of control (T<sub>1</sub>) and commercial starter diets**

Composition	T <sub>1</sub>	T <sub>2</sub>	T <sub>3</sub>	T <sub>4</sub>	T <sub>5</sub>
ME (Kcal/Kg)	2855.7	2950	3000	3000	2840
Crude Protein (%)	22	19	22	18	21
Crude Fibre (%)	3.34	5	4.3	12	4.0
Fat (%)	4.36	4.5	5.1	10	2.75
Calcium (%)	1.61	1.0	1.2	1.2	1.0
Phosphorus (%)	0.78	0.45	0.45	0.45	0.45
Lysine (%)	0.85	1.05	1.3	-	-
Methionine (%)	0.33	0.45	0.56	-	-

**Table 3 Proximate composition of control (T<sub>1</sub>) and commercial finisher diets**

Composition	T <sub>1</sub>	T <sub>2</sub>	T <sub>3</sub>	T <sub>4</sub>	T <sub>5</sub>
ME (Kcal/Kg)	2906.4	3000	3100	3000	2900
Crude Protein (%)	19.5	17	19.5	17	19
Crude Fibre (%)	3.2	5	3	15	6
Fat (%)	4.24	5	3.8	10	3
Calcium (%)	1.59	0.9	1.2	0.80	1
Phosphorus (%)	0.77	0.4	0.44	0.35	0.45
Lysine (%)	0.78	0.9	1.2	-	-
Methionine (%)	0.31	0.4	0.5	-	-

**Table 4: Meat quality characteristics of broiler chicken fed commercial diets**

Parameter	T <sub>1</sub>	T <sub>2</sub>	T <sub>3</sub>	T <sub>4</sub>	T <sub>5</sub>	SEM	P-value
Ph	5.82 <sup>b</sup>	6.09 <sup>a</sup>	6.07 <sup>a</sup>	5.90 <sup>ab</sup>	6.06 <sup>a</sup>	0.04	0.04
WHC(%)	34.33 <sup>b</sup>	33.33 <sup>b</sup>	42.00 <sup>a</sup>	34.33 <sup>b</sup>	38.00 <sup>ab</sup>	1.13	0.05
Cooking Yield	68.50 <sup>ab</sup>	65.77 <sup>bc</sup>	65.90 <sup>bc</sup>	58.77 <sup>c</sup>	75.80 <sup>a</sup>	1.74	0.01
Cooking Loss	31.50 <sup>bc</sup>	34.23 <sup>ab</sup>	34.10 <sup>ab</sup>	41.23 <sup>a</sup>	24.20 <sup>c</sup>	1.74	0.01

<sup>a,b,c</sup>; Means in the row not showing a common superscript are significantly different (P<0.05)

SEM = Standard Error of Means

WHC = Water Holding capacity

**Table 5: Carcass composition of broiler chicken fed commercial diets**

Parameters (%)	T <sub>1</sub>	T <sub>2</sub>	T <sub>3</sub>	T <sub>4</sub>	T <sub>5</sub>	SEM	P-value
Moisture	64.09 <sup>ab</sup>	65.25 <sup>a</sup>	65.62 <sup>a</sup>	65.34 <sup>a</sup>	61.24 <sup>b</sup>	0.65	0.13
Crude Protein	28.09 <sup>a</sup>	28.44 <sup>a</sup>	28.56 <sup>a</sup>	28.44 <sup>a</sup>	27.13 <sup>b</sup>	0.18	0.04
Ash	2.47	1.89	1.72	1.38	2.11	0.18	0.39
Fat	2.39 <sup>a</sup>	2.07 <sup>bc</sup>	2.16 <sup>ab</sup>	2.14 <sup>abc</sup>	1.87 <sup>c</sup>	0.06	0.02

<sup>a,b,c</sup>; Means in the row not showing a common superscript are significantly different (P<0.05)

SEM: Standard Error of Mean

**Table 6: Sensory properties of broiler chicken fed commercial diets**

Parameter	T <sub>1</sub>	T <sub>2</sub>	T <sub>3</sub>	T <sub>4</sub>	T <sub>5</sub>	SEM	P-value
Colour	6.03	6.33	6.07	6.30 <sup>a</sup>	6.13 <sup>a</sup>	0.15	0.96
Juiciness	6.43	7.00	6.30	6.63	6.40	0.14	0.54
Appearances	5.76	6.30	6.43	6.43	6.70	0.15	0.35
Flavour	6.10	6.50	6.30	6.53	6.57	0.14	0.82
Aroma	6.03	6.47	6.43	6.53	6.63	0.15	0.78
Tenderness	6.90	7.27	6.80	7.10	7.07	0.14	0.86
Overall Acceptability	6.47 <sup>b</sup>	7.30 <sup>ab</sup>	6.70 <sup>ab</sup>	7.20 <sup>ab</sup>	7.57 <sup>a</sup>	0.15	0.10

<sup>a,b</sup>; Means in the row not showing a common superscript are significantly different (P<0.05)

SEM: Standard Error of Mean

## REFERENCES

- Amaefule, K.U. and Obioha, F.C. (2001). Performance and nutrient utilization of broiler starter diets containing raw, boiled or dehulled pigeon seeds (Cajanuscajan). *Nigeria Journal of Animal Production*
- Ani, A.O and Okeke, G.C. (2011). The performance of broiler birds fed varying dietary levels of roasted pigeon pea (cajanuscajan) seed meal. *Pakistan Journal of Nutrition*. 10(11): 1036-1040.
- AOAC (1990). Association of Official Analytical Chemists. Official Methods of Analysis (21st edition) Washington D.C. USA
- Biesiada-Drzazga, B. (2008) Comparison of body weight and tissue composition of W11 and W31 White Koluda Breed geese. *Roczniki Naukowe Polskiego Towarzystwa Zootechnicznego* 4: 245-253.
- Delgado C.L., (2003). Rising consumption of meat and milk in developing countries has created a new food revolution. International Food Policy Research Institute, Washington, D.C.
- Duncan D B (1955) Multiple Range and Multiple F-test. *Biometrics*, 11:1-42.
- FAO (2013). Food and Agriculture Organization of the United Nations. Statistical Yearbook. Rome: FAO.
- Gardzielewska, J., Jakubowska, M., Karamucki, T., Rybarczyk, A. and Natalczk-Szkmkowska, A. (2009) Comparison of carcass and meat quality in seventeen-week old and three-year old geese. *Roczniki Naukowe Polskiego Towarzystwa Zootechnicznego* 5: 147-156.
- Gumulka, M., Kapkowska, E., Bobrowiec, F., Rabsztyn, A. and Poltowicz, K. (2006) Fatty acid profile and chemical composition of muscles and abdominal fat in geese from reserve and commercial lock. *Animal Science* 1 (supply): 90-91
- Jauregui, C.A., J.M. Regenstein, and R.C. Baker, (1981). A simple centrifugal method for measuring expressible moisture, A water binding property of muscle foods. *Journal of Food Science*. 46:1271-1273.
- Jiya, E.Z., Ijaiya, A.T., Ayanwale, B.A. and Olorunsanya, A.O. (2014). Meat quality characteristics and sensory evaluation of rabbits (*Oryctolagus cuniculus*) fed diets containing graded levels of processed tallow (*Detarium microcarpum*) seed meal. *Nigeria Journal of Animal Science Vol 16(2)* 318-32
- Joo S.T., Kim G.D., Hwang Y.H. and Ryu Y.C., (2013). Control of fresh meat quality through manipulation of muscle fiber characteristics. *Meat Science*, 95(4), pp. 828-36
- Kauffman, R.G., Cassens, R.G., Scherer, A., and Meeker, D.L. (1992). Variation in Pork Quality; History, Definition, Extent, Resolution. *A National Pork Producers Council Publication Washington D.C. USA*.

- Lara, J.A.F., Nepomuceno, A.L., Ledur, M.C., Ida, E.I. and Shimokomaki, M. (2003), Chicken PSE meat mutation in the ryanodione receptor gene. *Proceeding of international congress of meat science and Technology* 49: 79-81.
- Marchiori AF, deFelicio PE (2003). Quality of Wild boar meat and Commercial Pork. *Science Agriculture*. (Piracicaba, Braz) 60(1): 1–10
- Northcutt, J.K., E.A. Foegeding, and F.W. Edens, (1994). Water-holding properties of thermally preconditioned chicken breast and leg meat. *Poultry Science*. 73:308-316.
- Northcutt, J.K., E.A. Foegeding, and F.W. Edens, (1994). Water-holding properties of thermally preconditioned chicken breast and leg meat. *Poultry Science*. 73:308-316.
- Offer, G., and P. Knight, (1988). The structural basis of water-holding in meat. General principles and water uptake in meat processing. Pages 63-171 in: *Developments in Meat Science*. Elsevier Applied Science Publishing Co., Inc., New York, NY.
- Okubanjo AO (1997). Meat Characteristics of Singed and Conventionally dressed chevon carcasses *Journal of Food Science*. Technol. 34(6): 494–497.
- Omojola, A.B. and Adeshinwa, A.O.K. (2006). Meat characteristics of scalded, singed and conventional dressed rabbit carcasses. *International digital organization for Scientific information*. 1(1)24-29.
- Puvača. N., Kostadinovic, L.J., Popović, S., Lević, J., Ljubojević, D., Tufarelli, V., Jovanović, R., Tasić, T., Ikonić, P. and Lukač, D. Proximate composition, cholesterol content and lipid oxidation of meat of chicken fed dietary spice addition (*Allium sativum*, *Piper nigrum*, *Capsicum annum*). *Animal Production Science* 55: <http://dx.doi.org/10.1071/AN15115>
- SAS (2013). Statistical Analysis System Institute. Inc., Cary. North Caroline, USA.
- Toldrá F., (2006). Meat: Chemistry and Biochemistry. In: Hui Y. (ed.). *Handbook of food science, technology and engineering*. CRC Press, Taylor & Francis Group, Florida
- Vasanthakumar, P.K., Sharma, V. R. B., Sastry, and Kumar S., (1999). Effect of graded dietary level of neem seed kernel cake on carcass characteristics of boiler and rabbits. *International Journal of Poultry science*. 2(6), 309-312.



# WILLINGNESS TO PAY FOR SAFE BEEF CONSUMPTION IN KONTAGORA LOCAL GOVERNMENT AREA OF NIGER STATE, NIGERIA

Oseghale<sup>1\*</sup> A. I., S. Akinsola<sup>1</sup>, T.O Olarewaju <sup>2</sup>

<sup>1</sup> Department of Agricultural Economics and Farm Management, Federal University of Technology, P.M.B. 65, Minna, Niger State.

<sup>2</sup> Department of Forest Economics and Extension Services, Forestry Research Institute of Nigeria, P.M.B.5054, Jericho Hills Ibadan, Oyo State

\*Corresponding Author's E-mail: [itodine.agatha@futminna.edu.ng](mailto:itodine.agatha@futminna.edu.ng) GSM: [08033641643](tel:08033641643)

## ABSTRACT

*This study assessed the willingness to pay for safe beef consumption in Kontagora, Niger State. Primary data was collected from 100 respondents selected through multi staged sampling technique. Data were analyzed using descriptive statistics, contingent valuation and the Probit regression model. The results showed that the average age of the respondents was 46years with income less or equal to ₦50, 000. The result of the Probit regression showed that education, household size and percentage expenditure on beef increased the probability of paying for safe beef while age and maximum amount to pay had negative effect on the probability of paying for safe beef. The study recommended that safe beef in the study area should be sold at a price less or equal to ₦2, 000 and that beef consumers in the study area should be educated more on the need to eat safe beef so as to increase their willingness to pay.*

**KEYWORDS:** Consumption, Safe, Beef, Contigent valuation, Kontagora

## INTRODUCTION

Meat is one of the food necessary for human existence and it plays a very vital role in the growth and development of humans as meat products are rich sources of nutrients (Pereira and Vicente, 2013). It is highly nutritious and contains amino acid that are in form of protein and group B vitamins (particularly riboflavin, niacin), calcium, phosphorus and ash (Adetuji and Rauf, 2012). In Nigeria, 88.9% of the food commonly consumed by households consist of meat, fish and animal products and it is the fourth most commonly consumed food group after grains and flours (97.2%), oils and fats (96.8%) and vegetables (96.7%) (National Bureau of Statistics (NBS, 2016; Olumide and Carlos 2017). According to Food and Agriculture Organization beef is the third largest produced meat in the world and it is the most sold meat after poultry (FAO, 2014). World beef production is estimated at about 60 million tonnes carcass weight equivalent (CWE), growing at an average of 1.7% annually (USDA, 2014).

The meat industry in Nigeria is faced with some challenges such as sanitation problems of abattoirs, sales of meat in open market spaces (close to dirty water drainage facilities and refuse disposal sites). This could be attributed to inadequate planning of market and abattoirs, presence of illegal abattoirs and private slaughter rooms, inadequate water supply and lack of monitoring and enforcement of regulation (Iyiola and Oni-Ojo, 2013) and Mande (2011) stated

that dirty abattoirs and slaughter houses was one of the most difficult public health problem.

Food safety as defined by the FAO/WHO is the assurance that food when consumed in the usual manner does not cause harm to human health and well-being (WHO, 2002). Food safety issues concerning beef extends from the health and treatment of the live animal, through to slaughtering and final processing into beef and other products sold to the consumers. Most beef consumers in Nigeria are uninformed about the quality of beef they consume because of the absence of standard and quality labels (Ehirim *et al.*, 2013). Verbeke and Ward (2006) suggested that information about beef quality can be communicated to consumers through labels and beef certifications. The high consumption of meat globally has necessitated the need for meat safety since unsafe meat exposes consumers to potential hazards. Therefore this study assessed consumers' willingness to pay for safe beef in Kontagora LGA of Niger State, Nigeria.

## METHODOLOGY

### Study Area

The study was carried out in Kontagora. Kontagora is located between longitude 5.47°E and latitude 10.4°N. It has a tropical climate with an average temperature of 26.20c. April is the warmest month of the year with the average temperature of 29.3°c, and August having the lowest average temperature of

24.3<sup>0</sup>c. It has an annual rainfall of about 1533mm.

#### **Method of data collection**

Primary data were collected through the use of questionnaire. The questionnaire was used to obtain information that had to do with the socio-economic characteristics and willingness to pay for safe beef from the beef consumers.

#### **Sampling method**

Multistage sampling technique was employed in order to draw the sample for this study. In the first stage 5 areas including Federal college of education, Government Residential Area phase II, Tunga wawa, Rafin gora and Kanfaniwaye were purposively in order to have a representation of the low, medium and high income levels. In the second stage systematic sampling was used to select 20 respondents from each of the areas making a total of 100 respondents.

### **3.4 Method of data analysis**

#### **Descriptive Statistics**

Descriptive statistics such as mean frequency count, percentages, pie and bar charts respectively were used to describe the socio-economic characteristics, level of awareness of safe beef and willingness to pay for safe beef of the meat consumers in the study area. A three point rating scale of not aware (1) aware (2) Indifferent to aware (3) was also used to ascertain the level of awareness of consumers about safe beef consumption.

#### **Willingness to Pay**

Contingent valuation method was used to elicit consumers' willingness to pay for safe meat consumption while the probit regression analysis was used to determine the factors that influenced consumers' willingness to pay for safe beef. The model is stated as;

$$Y = F(X_1, X_2, X_3, X_4, X_5, X_6, X_7, U)$$

Y = Willingness to pay for safe beef meat (₦/kg)

X<sub>1</sub> = maximum amount willing to pay (₦/kg)

X<sub>2</sub> = monthly income (₦)

X<sub>3</sub> = gender (male =1 and female =0)

X<sub>4</sub> = age (years)

X<sub>5</sub> = marital status (married =1 and 0 otherwise)

X<sub>6</sub> = family size (no. of persons)

X<sub>7</sub> = years of education (years)

X<sub>8</sub> = % expenditure on meat

U = error term

### **RESULTS AND DISCUSSION**

The main tenet of this study was to assess consumers' willingness to pay for safe beef consumption in Kontagora, Niger State. The result in Table 1 revealed that, 34% of the respondents were aged between 31 and 40years with a mean age of 46years.

This implies that the study area was dominated by moderately aged who may be at higher risk of having health challenges due to beef consumption hence inclusion of unsafe beef in their diet makes them more vulnerable. This finding is in corroboration with Angul and Gil (2007) but in disagreement with Ehirim *et al.*, (2013) who stated that the mean age of safe beef consumers in Delta State was 28years, an indication that youths who understood the implications of health risks associated with unsafe food consumption dominated the study area. 51% of the respondents were female. This suggests that females may be the major determinants household food consumption and safety. This corroborates the finding of Mimi *et al.* (2010) and Ehirim *et al.* (2013) who stated that women dominated the study area and are particularly concerned about safety issues of the food their family members consume, but it is in disagreement with Xu and Wu (2010) who stated otherwise. The maximum household number is within a range of 1-5 (64%), with a mean of 4. This is an indication that the study area was made up of small households. This finding is in agreement with Angul and Gil (2007), however, Nnamdi (2010) revealed that the maximum household number was within a range 6-10 (46%), with an average mean household size of 9.

Table 1 also showed that, majority (67%) of the consumers had formal education (primary, secondary or tertiary) with secondary school having the highest percentage of 40%. This indicates that most of the meat consumers in the study area were literate, signifying that consumers in the study area may be aware of the disadvantages of unsafe meat consumption.

Furthermore, table 1 showed the distribution of respondents by income. Majority (72%) of the respondents earned ₦50,000 or less. This is an indication that beef consumers in the study area were low income earners. However, only about 2% of the respondents earned ₦200,000 and above. This is in line with Akerele *et al.* (2010) who found that the average monthly income among *kilishi* consumers in Sokoto North-West, Nigeria was of ₦16, 971.98.

#### **Willingness to Pay for Safe Beef Consumption**

Table 2 revealed that majority (56%) of the consumers in the study area were aware of meat safety. Therefore, they may be willing to pay for safe meat knowing the implications of unsafe meat consumption. Consequently, it becomes rational for the consumers to be positive about paying for safe beef so as to prevent the harmful effects of consuming contaminated beef. Ehirim *et al.* (2013), also reported that a higher percentage of the beef consumers in Delta State were aware of the advantages of consuming safe meat and the likely



risks involved in the consumption of unsafe food product.

Consumers in the study area were willing to pay for safe meat as indicated by 84.0% of the respondents (Table 2). This is probably because they were aware of the risk involved with unsafe meat consumption and they may be concerned about their health issues. This is however not surprising because majority of the consumers were educated. This study corroborates with Iyiola and Oni-Ojo (2013) who reported that consumers were willing to pay for quality product if the meat industry would involve itself in advanced practices like packaging, labelling and so on, but in disagreement with Angul and Gil. (2007) who observed, that even though consumers were more aware of food safety issues, about 72.5 % of them were not willing to pay a premium for labelled beef (packaged). Also, table 2 showed that, 27% of consumers in the study area were willing to pay between ₦ 500-1000 per kg for safe meat as against ₦800 which is the normal price of 1kg of meat sold in the open market in the study area, with a mean amount of ₦ 2000. This implies that beef consumers in the study area were willing to pay a price over 100% higher than the price beef was sold in the market. This confirms the study of Xu and Wu (2010) who reported that consumers who had a knowledge of the health risks associated with quality impaired food items were more likely to pay for certified food.

#### **Factors Influencing Willingness to Pay for Safe Beef**

Table 3 shows the factors that influenced willingness to pay for safe beef in the study area. While education, household size and expenditure had positive and significant effect on willingness to pay, age and maximum amount to pay had negative effect on WTP.

This implies that beef consumers with higher education had a higher probability of paying for safe beef than those without education. That is, an increase in education by a year will increase the probability of paying for safe beef by 2.1% (4). This may be explained based on the premise that education enhances level of awareness. This is similar to Akinbode *et al.* (2012) who also found that education had positive effect on willingness to pay for safe street food in Southwest Nigeria. Also, the positive coefficient of household size signifies that households with more number of people had a higher probability of paying for safe beef. This could be because large households may have different sources of income and therefore higher household income. This however, depends on the composition of the household. Likewise, a percentage increase in the

expenditure on beef will increase willingness to pay by 1.1%.

On the other hand, the coefficient of age was negative. Implying that older respondents are likely to pay less for safe beef consumption. This could be because, older people may be aware that they should consume less meat. Therefore, there is probability that they substitute beef with other protein sources instead of paying extra for beef. More so, the youths are more exposed and should be more attracted to well package beef. This finding disagrees with Obi-Egbedi *et al.* (2017) who reported that age had positive effect on willingness to pay for safe beef in Oyo State. In addition, an increase in the maximum amount to pay by a naira will decrease the probability of paying for safe beef by 2.7%. This follows the theory of demand which states that there is an inverse relationship between the price of a commodity and its demand. This finding is in line with Akinbode *et al.* (2012) who also reported that maximum bid price had a significant but negative influence on willingness to pay.

#### **CONCLUSION AND RECOMMENDATIONS**

This study assessed the willingness to pay for safe beef in Kontagora LGA of Niger State. Based on the findings of this study, it can be concluded that beef consumers in the study area were aware of unsafe beef and were therefore willing to pay for the consumption of safe beef. However, this was influenced by education, household size, and percentage expenditure on beef, age and maximum amount to pay. Thus, the study recommended that beef sellers in the study area can venture into the sales of well packaged beef, however, the price of the beef should not exceed ₦2000/kg. Also, the people of Kontagora should be educated about the advantages involved in consumption of safe meat so as to increase their willingness to pay.



Table 2 : Socio-economic Characteristics of Beef Consumers in the Study Area

<b>Description</b>	<b>Frequency</b>	<b>Percentages</b>
<b>Age</b>		
Less than 21	1	1.0%
21-30	22	22.0%
31-40	34	34.0%
41-50	31	31.0%
51-60	9	9.0%
Greater than 60	3	3.0%
<b>Mean</b>	46	
<b>Gender</b>		
Male	49	49.0%
Female	51	51.0%
<b>Household Size</b>		
1-5	64	64.0%
6-10	29	29.0%
11-15	6	6.0%
16-20	1	1.0%
<b>Mean</b>	4	4.0%
<b>Educational Level</b>		
No Formal Education	33	33.0%
Primary	14	14.0%
Secondary	40	40.0%
Tertiary	13	13.0%
<b>Income(N/month)</b>		
1000-50000	72	72.0%
51000-100000	16	16.0%
101000-150000	7	7.0%
151000-200000	3	3.0%
Above 200000	2	2.0%
<b>Mean</b>		

Source: Field Survey, 2015

Table 2: Willingness to pay for safe beef

Description	Frequency	Percentage
<b>Consumers awareness of safe beef</b>		
Aware	56	56.0%
Not Aware	9	9.0%
Indifferent	35	35.0%
<b>Willingness to pay for safe beef</b>		
Yes	84	84.0%
No	16	16.0%
<b>Willingness to Pay (₦)</b>		
1-500	25	25.0%
501-1000	27	27.0%
1001-1500	9	9.0%
1501-2000	13	13.0%
Greater than 2000	16	16.0%
<b>mean</b>	2000	

Source: Field Survey, 2015

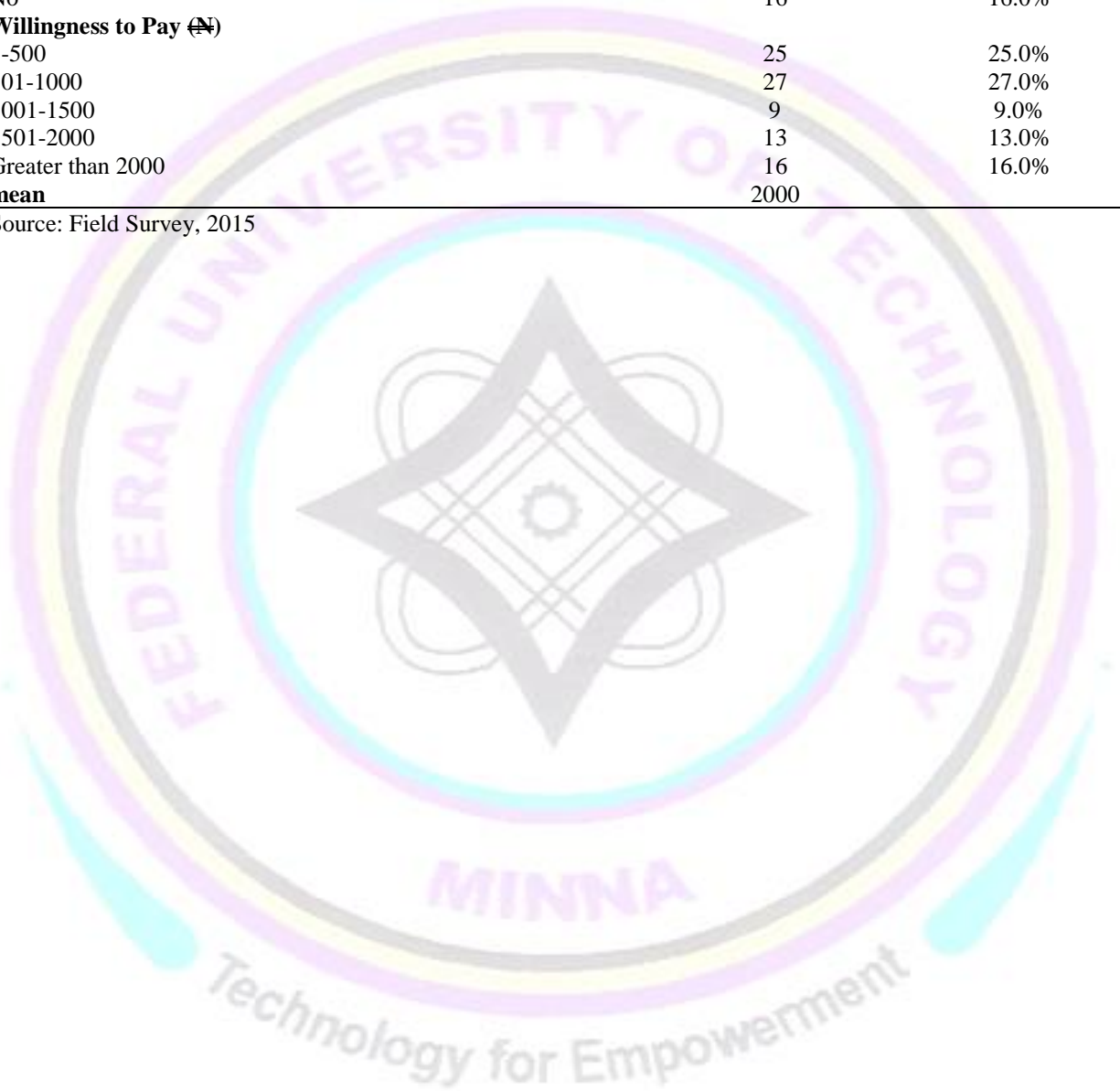


Table 3. Factors Affecting Willingness to pay for Safe beef in the Study Area

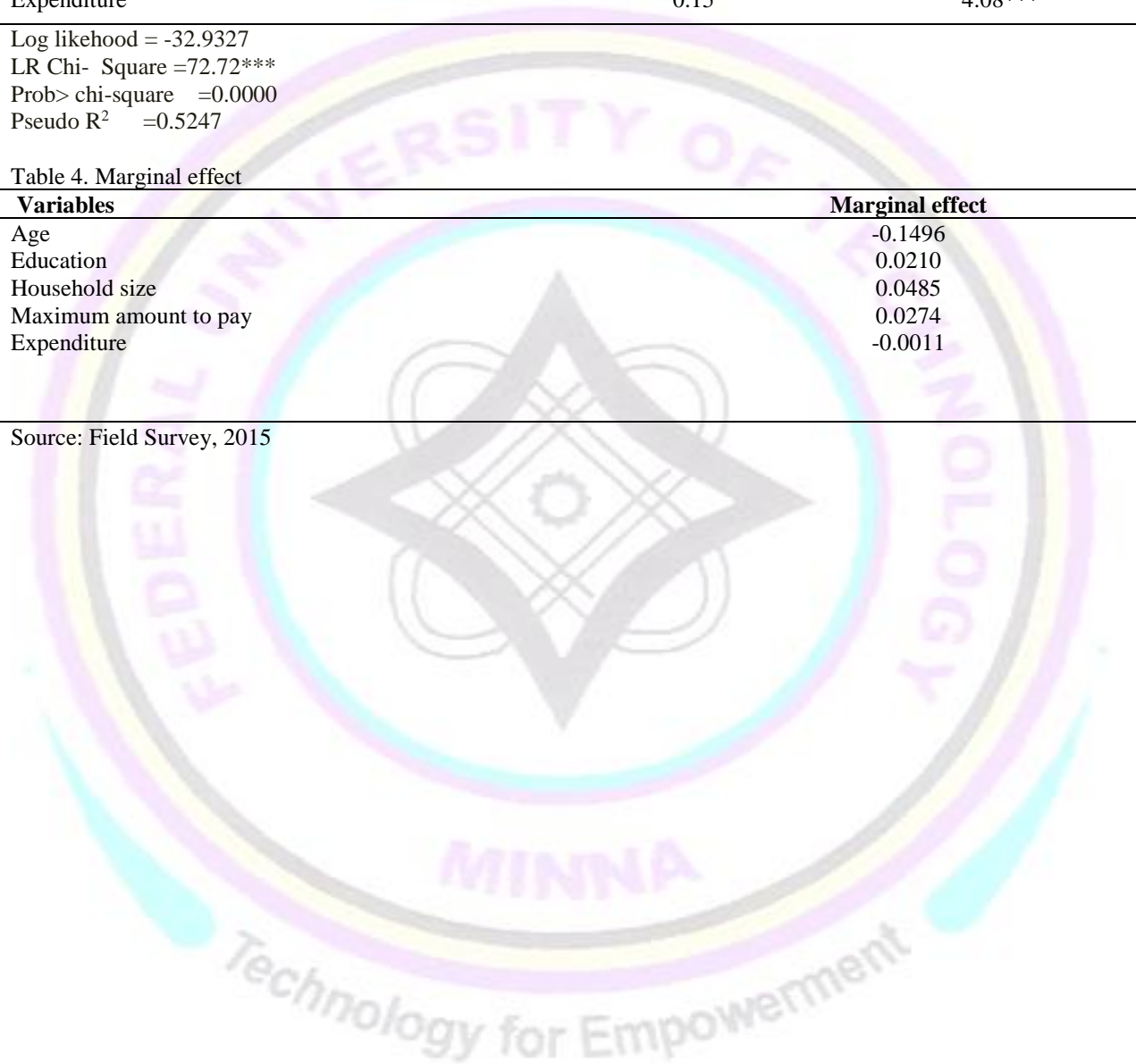
<b>Variables</b>	<b>Coefficient</b>	<b>Z-values</b>
Age	-0.08	-3.00***
Education	0.12	3.04***
Household size	0.27	2.81***
Gender	0.29	0.79
Income	-0.81	-0.66
Max amount to pay	-0.01	- 2.09**
Expenditure	0.15	4.08***

Log likelihood = -32.9327  
 LR Chi- Square =72.72\*\*\*  
 Prob> chi-square =0.0000  
 Pseudo R<sup>2</sup> =0.5247

Table 4. Marginal effect

<b>Variables</b>	<b>Marginal effect</b>
Age	-0.1496
Education	0.0210
Household size	0.0485
Maximum amount to pay	0.0274
Expenditure	-0.0011

Source: Field Survey, 2015





## REFERENCES

- Adetunji, M. O. and Rauf, M.O (2012). Analysis of Household Demand for Meat, in Southwest, Nigeria. *Global Journal of Science Frontier Research Agriculture & Biology (12) 1 Version 1.0 Global Journals Inc. (USA)* Online ISSN: 2249-4626 & Print ISSN: 0975-5896.
- Akerele D., Akinbode S.O. and Dipeolu A.O. (2010). Willingness to pay for the Safety of *Kilishi* in Sokoto, Nigeria. *Journal of Agricultural and Food Information*. 11:330-339.
- Akinbode S. O., Dipeolu A. O. and Okojie L. O. (2012). Estimating consumers' willingness to pay for safety of street foods in South-west Nigeria. *Nigerian Journal of Agricultural Economics (NJAE)* 3(1): 28 – 39
- Angul, A. M., and Gil, J. M., (2007). Risk Perception and Consumer Willingness to Pay for Certified Beef in Spain. *Food Quality and Preference* 18: 1106–1117.
- Ehirim, N.C., L.O.E. Nwauwa, and E.E. Ikheloa. 2013. Determinants of consumer preference for safe beef in Delta State, Nigeria, *Wudpecker Journals of Agricultural Research*, 2(3): 073-079.
- Food and Agriculture Organisation (FAO), (2014). World Food Outlook. Accessed at <http://www.fao.org/ag/againfo/themes/en/meat/background.html>
- Iyiola O. and Oni-Ojo E.E. (2013). Attitudes toward Service Innovations in Red Meat Industry and its Consumption Effects on Nigerian Consumers. *Developing Country Studies*. 3(9): 39-49
- Mande. B., 2011. Policy Guidelines on Market and Abattoir. [tsaftarmuhalli.blogspot.com/2011/](http://tsaftarmuhalli.blogspot.com/2011/)
- Mimi L., Alias R. and Mohammed R. (2010). Consumer Perception towards Meat Safety: Confirmatory Factor Analysis. *International Journal of Economics and Management* 4(2): 305 – 318.
- National Bureau of Statistics (NBS), (2016). LSMS - Integrated Surveys on Agriculture General Household Survey Panel 2015/2016. Nigerian National Bureau of Statistics.
- Nnamdi C. (2010). Determinants of consumers' Preference for Safe Chicken Consumption in Imo State, Nigeria. *Researcher*, 2(12) <http://www.sciencepub.net/researcher>
- Obi-Egbedi, O., Ahmed, J., & Israel, J. M. (2017). Consumers' Willingness to Pay for Safe Beef In Ibadan-North Local Government, Oyo State, Nigeria. *Archives of Business Research*, 5(6): 18-28.
- Olumide A and Carlos E.C. (2017). Household Demand for Meat in Nigeria. Selected Paper prepared for presentation at the Southern Agricultural Economics Association's 2017 Annual Meeting, Mobile, Alabama, February, 4-7 2017
- Pereira, P. M. C. C and A. F. R. B Vicente. (2013). Meat Nutritional Composition and Nutritive Role in the Human Diet. *Meat Science*, 93: 586-592.
- Verbeke, W. and R.W. Ward (2006). Consumer interest in information cues denoting quality, traceability and origin: an application of ordered probit models to beef labels, *Food Quality and Preference*, 17(6): 453-467.
- World Health Organization (WHO), (2002). Global Strategy for Food Safety, Genera WHO.
- Xu, L. and L. Wu (2010). Food safety and consumer willingness to pay for certified traceable food in China, *Journal of Science, Food and Agriculture*, 90: 1368-1373.

## DIETARY PROTEIN REQUIREMENT FOR GROWTH PERFORMANCE AND NUTRIENT DIGESTIBILITY OF FUNAAB ALPHA BROILER CHICKENS

Olawuyi, D.O., Alabi, O.J., Jiya, E.Z., Egena S.S.A. and Alemede, I.C.

Department of Animal Production, School of Agriculture and Agricultural Technology,  
Federal University of Technology,

P. M. B 65, Minna

Niger State, Nigeria.

[alabioj@gmail.com](mailto:alabioj@gmail.com)

Phone number: 09030083008

### ABSTRACT

A thirteen-week trial was carried out at the Teaching and Research Farm of the Federal University of Technology, Minna Nigeria to determine dietary protein requirement for growth performance and nutrient digestibility of FUNAAB Alpha broiler chickens. A total of one hundred and twenty (120) day-old of FUNAAB Alpha chicks was used for the study. The chicks were grade and randomly allocated to four varying dietary protein levels of 14, 17, 20 and 23 % CP and were tagged CP14, CP17, CP20 and CP23, respectively. The birds were allocated to the four treatments using a Completely Randomized Design (CRD). Each treatment group was replicated thrice with ten birds per replicate. The birds were housed in deep litter system where they received uniform care and management. The experiment lasted for thirteen weeks. Light was provided 24 hours daily, while feed and clean cool drinking water were given *ad libitum*. Data on feed intake, daily weight gain, FCR and nutrient digestibility were collected and subjected to one-way analysis of variance where differences occurred, they were separated using Duncan multiple range test. There were no differences ( $P>0.05$ ) in all the growth parameters measured. Digestibility results indicated that dietary treatments had effect ( $P<0.05$ ) in all the parameters measured. The birds on CP 14 % had better ( $P<0.05$ ) DM (89.82 %), CF (81.90 %) and ash (70.17 %) digestibility than all the other treatments. It was thus, concluded and recommended that CP level of 14 % is adequate for FUNAAB Alpha chickens since there were no significant difference between this level and other higher protein levels used. This level also gave the highest DM, CF and ash digestibility.

**KEYWORDS:** Protein, FUNAAB Alpha, Performance, Digestibility

### INTRODUCTION

The poultry industry is one of the most important sectors of the Nigerian economy contributing substantially to the nation's Gross Domestic Product (Ambali *et al.*, 2003). In 2005 the population of poultry was estimated to be about 190 million (Orajaka, 2005) comprising of 8.0 % exotic breeds and over 90 % indigenous species (Nwanta *et al.*, 2006). Local chickens play an important role as household food supply in rural areas of developing countries (Zaman *et al.*, 2008). It is also a means of providing additional income to the generally resource-poor small holder farmers (Gueye, 2003), thereby helping to alleviate poverty.

Despite the fact that more than 90 % of the Nigeria poultry production system consists of local chickens, their contribution to human nutrition, gross domestic products and export earnings are disproportionately low. These problems are poor growth rate (reaching maturity at 3-4 months, laid few eggs), genetic makeup and environmental management (King'ori *et al.*, 2003). In all this nutrition plays a major role. One of the major nutrients is protein. Protein is one of the most important dietary macronutrients for animals, and as the key component of cells, plays an important role in the process of life.

Various authors have work on the dietary protein

requirement for indigenous chickens. Chemjor (1998) reported that a dietary protein level of 13 % was adequate for indigenous chickens aged between 14 and 21 weeks. King'ori *et al.* (2003) observed that indigenous chickens require a protein level of 16 % to optimize feed intake and growth between 14 and 21 weeks of age. Furthermore, Ndegwaet *al.* (2001) reported that indigenous chickens fed diets containing 17 to 23 % CP had similar growth rates and feed intakes, suggesting that a 17 % CP diet was sufficient for these chickens. King'ori *et al.* (2003) compared the effect of varying crude protein levels of 100, 120, 140, 160 and 180 g/kg DM on the feed intake, feed conversion ratio and live weight of growing indigenous chickens raised intensively between 14 and 21 weeks of age. Results from this study indicate that feed intake per bird increased with increasing dietary protein levels. Similarly, live weight gain increased with increasing protein levels while feed conversion ratio decreased with increasing dietary protein levels. The results from literature on dietary protein requirement varies and thus inconclusive.

FUNAB alpha is an indigenous broiler breed developed through crossbreeding and intensive selection over many generations; this bird was developed at the Federal University of Agriculture of Agriculture, Abeokuta, Nigeria for improved meat and egg production without compromising the adaptation to tropical climate and diseases. There are limited studies on the protein requirement of this breed of chicken. This study was carried out to determine the dietary protein requirement of growth performance and nutrient digestibility of FUNAAB Alpha broiler chickens.

## METHODOLOGY

The study was carried out in the poultry section of the Teaching and Research Farm of the Department of Animal Production, Federal University of Technology, Gidan Kwano Campus, Minna, Niger State. Minna is located between latitude 4° 30 and 9° 37 North and longitude 6°33 and 06°45 East with an altitude of 1475 m above sea level (Niger State Agricultural Development Project; NSADP, 2009). The area falls within the Southern Guinea Savannah vegetation zone of Nigeria with average annual

rainfall of between 1100 and 1600 mm and a mean temperature of between 21° and 36.5° C (Ovimap, 2016). Minna experiences two distinct seasons (dry, from November to March, and wet or rainy season from April to October). The study was conducted between May and September, 2018. The experimental ingredients (Table 1) used for the research were obtained from Minna UltraModern Market, Minna Niger State. FUNAAB Alpha chicks were obtained from Federal University of Technology Abeokuta, Ogun State, Nigeria.

A total of one hundred and twenty (120) day-old of FUNAAB Alpha chicks was used for the study. The chicks were grade and randomly allocated to four varying dietary protein levels of 14, 17, 20 and 23 % CP and were tagged CP<sub>14</sub>, CP<sub>17</sub>, CP<sub>20</sub> and CP<sub>23</sub>, respectively. The birds were allocated to the four treatments using a Completely Randomized Design (CRD). Each treatment group was replicated thrice with ten birds per replicate. The birds were housed in deep litter system where they received uniform care and management. The experiment lasted for thirteen weeks. Light was provided 24 hours daily, while feed and clean cool drinking water were given *ad libitum*

## Data Collection

On arrival, the initial live weights of chicks were taken at the commencement of each experiment. Thereafter, average live weights per bird were measured at weekly intervals by weighing the chickens in each pen and the total weight was divided by the total number of birds in each pen. These live weights were used to calculate body weight gain of the chickens. Weekly mean feed intakes were determined until termination of the experiment. These weights were used to calculate daily mean feed intake.

**Feed intake:** A known quantities of feed were offered every morning and the left over were measured the next morning. The difference between the feed offered and the leftover was considered as feed intake. This was carried out daily.

**Body weight gain:** This were measured weekly



per bird. The current body weights were subtracted from the weight of the previous week to obtain the weekly weight gain.

#### Feed Conversion Ratio (FCR)

Feed conversion ratio was computed as the ratio of feed intake to weight gain (g).

#### Feed Conversion Ratio (FCR)

=Average weekly feed intake/ Average weekly weight gain (Egbewande, 2009)

#### Nutrients Digestibility

A total collection method was used. This was determined when the chickens are between 84 and 91 days old. Two birds per replicate were randomly selected from each replicate were transferred to specially construct metabolic cages. They were allowed three days acclimatization, thereafter, fasted overnight and the feed and water were served *ad-libitum* to the chickens. Their total droppings were collected for four days. The total fecal collected were bulked and oven at 85 °C until a constant weight was gotten. Proximate composition of the feed and droppings were analyzed in the Animal Production Laboratory according to the methods and procedure of AOAC (2013). The nutrients digestibility was determined using the formula below.

Digestibility coefficient =  $\frac{\text{Nutrient in Feed Intake} - \text{Nutrient in dropping voided}}{\text{Nutrient in Feed Intake}}$  (Aduku and Olukosi, 1990)

#### Statistical Analysis

All data collected on feed intake, body weight gain, digestibility, growth rate, feed conversion ratio, live weight and apparent nutrient digestibility of the chickens were analyzed by one-way analysis of variance (ANOVA) in a Completely Randomized Design (SAS, 2012) and where there were mean differences, they were separated using Duncan's Mutiple Range Test (SAS 2012).

## RESULTS AND DISCUSSION

The results of the growth performance of FUNAAB

Alpha chickens fed different levels of dietary crude protein are presented in Table 2. All the growth parameters measured were not influenced ( $P>0.05$ ) by the dietary treatments. The might imply that CP level of 14 is adequate for FUNAAB Alpha broiler chickens. The results obtain from this study is similar to those reported by Aftab (2009) who did not observed differences in the feed intake of broiler chickens at day 21 and 35 when the birds were fed diets containing different ME and protein concentrate. The CP 14 observed in this study is lower than NRC (1994) recommendation of 23, 20 and 18 % dietary protein levels for the broiler chickens during the starter, grower and finisher phases respectively, for optimal growth and maximum productivity. Furthermore, it is lower than those of Tadelle and Ogle (1996) who observed that the protein requirement of growing indigenous chickens varies between 16 and 18 % during the growing phase for optimal performance. The results observed in this study is close to the 13 % recommended by Chemjor (1998); who reported that a dietary protein level of 13 % was adequate for indigenous chickens aged between 14 and 21 weeks.

The apparent nutrient digestibility on FUNAAB Alpha chickens fed different levels of dietary crude protein results are presented in Table 3. Unlike the growth performance results all the parameter measured were influenced ( $P<0.05$ ) by the dietary treatments. There was a negative relationship in the dry matter, crude fibre and ash contents digestibility. As the dietary crude protein increased the dry matter, crude fibre and ash contents digestibility decreased. This might imply that high in, crude fibre and ash contents digestibility inclusion levels of dietary protein are wasted by the birds since they are not well digested. This might be the reason that it was observed that CP level of 14% was adequate for the performance of FUNAAB Alpha broiler chickens.

## CONCLUSION AND RECOMMENDATIONS

It was thus, concluded and recommended that CP level of 14 % is adequate for FUNAAB Alpha chickens since there were no significant difference between this level and other higher protein levels used. This level also gave the highest DM, CF and ash digestibility.



**Table 1. Ingredient Composition of Experimental Diets (g/Kg)**

INGREDIENT	CP <sub>14</sub>	CP <sub>17</sub>	CP <sub>20</sub>	CP <sub>23</sub>
Maize	71.90	61.00	51.00	48.00
GNC	1.20	2.35	2.20	12.00
Full fat soya	9.50	18.00	27.80	26.00
Maize bran	10.20	12.00	12.80	7.50
Fish meal	2.00	2.00	2.00	2.00
Bone meal	3.00	3.00	3.00	3.00
Methionine	0.25	0.25	0.25	0.25
Lysine	0.75	0.75	0.75	0.75
Premix	0.50	0.50	0.50	0.50
Salt	0.25	0.25	0.25	0.25
Total	10.00	100.00	100.00	100.00
Calculated CP (%)	14.14	17.33	20.47	23.25
Calculated Energy (Kcal/kg)	3124.11	3104.62	3101.02	3054.10
Ether Extract	5.12	4.15	5.24	6.24
Crude Fiber	5.86	5.47	4.77	4.88

CP<sub>14</sub> = Crude Protein 14, CP<sub>15</sub> = Crude Protein 15, CP<sub>16</sub> = Crude Protein 16, CP<sub>17</sub> = Crude Protein 17

**Table 2. Growth Performance of FUNAAB Alpha Chickens fed Different Levels of Dietary Crude Protein**

Parameter	CP <sub>14</sub>	CP <sub>17</sub>	CP <sub>20</sub>	CP <sub>23</sub>	SEM	SIG
Initial Weight	604.33	608.33	618.33	627.00	6.86	0.24
Final Weight	2133.33	2366.67	2366.67	2300.00	80.21	0.40
Feed intake	60.30	72.73	62.81	62.81	3.11	0.34
Weight Gain	1529.00	1758.33	1748.33	1673.00	80.78	0.42
Daily Weight Gain	23.01	28.17	28.17	27.38	1.12	0.15
Feed Conversion Ratio	2.64	2.54	2.23	2.37	0.09	0.19
Protein Efficiency Ratio	1.90	1.83	2.13	1.90	0.07	0.20

CP<sub>14</sub> = Crude Protein 14, CP<sub>15</sub> = Crude Protein 15, CP<sub>16</sub> = Crude Protein 16, CP<sub>17</sub> = Crude Protein 17



**Table 3. Apparent Nutrient Digestibility on FUNAAB Alpha Chickens fed Different Levels of Dietary Crude Protein (%)**

PARAMETRS	CP14	CP17	CP20	CP23	SEM
Dry Matter	89.02a	88.53b	83.41c	82.58d	0.88
Crude Protein	87.28a	87.28a	81.31b	80.15c	1.00
Crude Fiber	81.90a	78.37b	73.65c	66.78d	1.71
Ether Extract	80.30b	80.13b	68.53c	82.88a	1.68
Ash	70.17a	61.52b	56.44c	42.76d	3.00
Nitrogen Free Extract	94.98a	94.92a	92.12b	91.94b	0.45

abcd : mean with different superscripts along the row are significantly different at  $p < 0.05$

CP<sub>14</sub> = Crude Protein 14, CP<sub>15</sub> = Crude Protein 15, CP<sub>16</sub> = Crude Protein 16, CP<sub>17</sub> = Crude Protein 17

### REFERENCES

References are presented in APA format please.

- Aduku, A.O., and Olukosi J.O. (1990). Rabbit Management in the Tropics. Living Book Series. G.U. Publication. Abuja, Nigeria Pp 2-5.
- Aftab, U. Response of Broilers to Practical Diets with Different Metabolizable Energy and Balanced Protein Concentrations. Brazilian Journal of Poultry Science. 11 (3): 169 - 173.
- Ambali, A. G., Abubakar, M.B, & James, T.E, (2003). An Assessment of Poultry Health Problems In Maiduguri, Borno State, Nigeria. Tropical Veterinarian. 21: 138-145
- Chemjor, W. 1998. Energy and protein requirements of indigenous chickens of Kenya Msc thesis (Unpublished), Egerton University, Kenya, pp. 83
- Egbewande ,O.O. (2009). Poultry industry and alternative feedstuffs. P roceeding 14th Annual Conference of Animal Science Association of Nigeria. Ladoke Akintola University of Technology, Ogbomosho. Pp 385-386.
- Gueye, E.F. 2003. Production and consumption trends in Africa. World Poult. Sci. 19 (11): 12-14.
- King'ori, A.M., J.K. Tuitoek, H.K. Muiruri. and A.M. Wachira. (2003). Protein requirements of growing indigenous chickens during the 14-21 weeks growing period. S. Afr. J. of Ani. Sci. 33 (2): 78-82.
- Ndegwa, J.M., Mead, R., Norrish, P., Kimani, C.W., and Wachira, A.M. (2001). The performance of indigenous Kenya chickens fed diets containing different protein levels during rearing. Tropical Animal Health and Production 33: 441-448.
- NRC, 1994. Nutrient Requirements of Poultry. 9th Revised edition. National Academy Press: Washington, DC
- Nwanta, J.A, Umoh, J.U, Abdu, P.A, Ajogi, I. and Ali Balogun, J.K. (2006). Management of Losses and Newcastle Disease In Rural Poultry In Kaduna State, Nigeria. Nigerian Journal of Animal Production 33 (2): 274-285.
- Orajaka, L.J.E, (2005). The Role of Local Chicken In Poultry Production In Nigeria. Nigerian Veterinary Journal 26: 68-72.
- Ovimaps (2016). Ovi location map; Ovi Earth Imager.
- SAS, (2012). Statistical Analysis System. SAS User Guide: Release 9.2. SAS Institute, Cary NC.
- Tadelle, D. and Ogle, B. (1996). Effect of maize (*Zea mays*) and noug (*Guizotia abyssinica*) cake supplementation on egg production performance of local birds under scavenging conditions in the central highlands of Ethiopia. M.sc Thesis, Swedish University of Agricultural Sciences, pp14.
- Zaman, Q.U., Mushtaq, T., Nawaz, H., Mirza, M.A., Mahmood, S., Ahmad, T. M.E., Babar, M.E and Mushtaq, M.M.H. (2008). Effect of varying dietary energy and protein on broiler performance in hot climate. Animal Feed Science and Technology 146:302-312

## **GROWTH PERFORMANCE AND NUTRIENT DIGESTIBILITY OF BROILER CHICKENS FED WOOD ASH BASED DIETS AT BOTH STARTER AND FINISHER PHASES**

**Alabi, O.J., Alemede, I.C. Egena S.S.A, Obari, O.C. Ewa, E.C, and Oyinloye, J.O.**

Department of Animal Production, School of Agriculture and Agricultural Technology,  
Federal University of Technology,

P. M. B 65, Minna

Niger State, Nigeria.

[alabioj@gmail.com](mailto:alabioj@gmail.com)

Phone number: 09030083008

### **ABSTRACT**

An eight-week study was conducted to determine the effect of different firewood ash-based diets growth performance and nutrient digestibility of broiler chickens at both the starter and finisher phases. A total of 120 broiler chickens were randomly allocated to four treatments in the completely randomized design. Treatments 1, 2, 3, and 4 are No ash (control), NTA (Neem tree ash), SBA (Shea butter ash) and LBA (Locust bean ash), respectively. Each treatment was replicated three times with ten birds per replicate. Data on feed intake, daily weight gain, FCR and nutrient digestibility were collected and subjected to one-way analysis of variance where differences occurred, they were separated using Duncan multiple range test. Starter phase results shows that dietary treatments had effect on final weight, body weight gain and feed intake. Birds on STA having higher (366.00 g) weight, body weight gain (173.71 g) and feed intake (546.03 g) than the control. At the finisher phase, dietary treatments had effect on the final weight with birds on NTA having the highest final weight (1238.15 g), daily weight gain with birds on SBA having the highest daily weight gain (32.88 g), FCR with birds on SBA having better conversion FCR (2.84). The digestibility results indicated birds on LBA diet had the highest crude fibre (79.87 %) and ash content (69.56 %). It is recommended that any of the wood ash could be use, as they had similar effects in terms of final weight, daily weight gain, FCR, crude fibre digestibility and ash content digestibility and birds on the wood ash treatments performed better than the control.

**KEYWORDS:** wood ash, performance, digestibility

---

## INTRODUCTION

Broiler production plays a major role in food security for the rapidly increasing human population. Their short production cycle, high feed efficiency and high biomass per unit of agricultural land are particularly attractive for the production systems (Talpur *et al.*, 2012). The present broiler chicken has been genetically selected for rapid growth, increased muscle mass and heavier breast weight (Garner *et al.*, 2002). These genetic potentials cannot be fully utilized or expressed if the right or optimal nutrient is not provided, it implies that animals should be adequately provided with the right kind of nutrients for the maximum expression of their genetic endowment. Modern broiler strains have very rapid growth for which their requirement for oxygen, nutrients, enzymes, hormones, and growth factors has increased in comparison to earlier strains (Onimisi *et al.*, 2014). Additionally, the supportive systems are challenged to maintain structure, function, and to satisfy demands of tissues during growth. Thus, it is extremely important that their metabolism and bones support the increasingly heavier body weight and muscle mass that are obtained in younger ages as genetic selection for growth progresses.

Mineral imbalance, particularly of calcium (Ca) is one of the problems responsible for economic losses to poultry industry (Talpur *et al.*, 2012). Maintenance of calcium and phosphorus (P) ratio at 1:0.5 is essential for performing various functions in the body. Generally, minerals are responsible for proper osmo-regulation in addition to maintaining nervous and muscular coordination and blood coagulation in the animal's body (Adamu *etal*, 2012).

Calcium is the mineral with the highest concentration in the body of poultry, consisting of 1.5 % of its body weight (Pelicia *et al.*, 2011). Calcium plays two important physiological roles in the poultry. First, it provides the structural strength of the poultry skeleton by the formation of calcium salts. Second, it plays vital roles in many of the biochemical reactions within the body via its concentration in the extracellular fluid (Vahid *et al.*, 2014). Deficiency of calcium, for instance, leads to development of rickets, tibial dyschondroplasia (TD), increased chick's mortality and reduced body weight in older birds (Underwood and Suttle, 2001).

Supplying diets with adequate calcium levels is essential for bone formation to support high growth

rates in broilers (Costa *et al.*, 2009). Supporting muscles and protects delicate organs and tissues, including the bone marrow, but is also jointed to allow movement, and is malleable to allow growth.

There are several studies in literature on the calcium requirements of broilers (Alveset *al.*, 2002; Araujo *et al.*, 2002; Sa *et al.*, 2004; Santos *et al.*, 2011; Tancharoenrat and Ravindran, 2014), out of which some have evaluated calcium sources, such as calcium bicarbonate (Alveset *al.*, 2002), calcium citrate-malate (Henry and Pesti, 2002), and calcitic and dolomitic limestone (Saet *al.*, 2004). However, there are limited studies on the use of firewood ash as a calcium source for broilers at the finisher phase. The objective of this study was to evaluate effect of firewood ash-based diet on the performance and nutrient digestibility of broilers.

## METHODOLOGY

The study was carried out in the poultry section of the Teaching and Research Farm of the Department of Animal Production, Federal University of Technology, Gidan Kwano Campus, Minna, Niger State. Minna is located between latitude 4° 30 and 9° 37 North and longitude 6°33 and 06°45 East with an altitude of 1475 m above sea level (Niger State Agricultural Development Project; NSADP, 2009). The area falls within the Southern Guinea Savannah vegetation zone of Nigeria with average annual rainfall of between 1100 and 1600 mm and a mean temperature of between 21° and 36.5° C (Ovimap, 2016). Minna experiences two distinct seasons (dry, from November to March, and wet or rainy season from April to October). The study was conducted between May and July, 2017.

## Origin and Managements of Birds and Other Ingredients

Broiler birds used in the experiments were purchased from Globus Resources Limited in Ijesha- Tedo, Lagos State, Nigeria. Other ingredients used in the formulation of the feed were purchased from the Minna Central Market (Kure), Niger State. Fresh *Azadirachta indica* (Neem), *Parkia biglobosa* (African Locust bean) and *Vitellaria paradoxa* (Shea butter tree) woods were collected from within the Gidan Kwano campus. This was because of their abundance, availability and accessibility. The woods including the barks collected were broken into pieces to hasten the drying process and sun dried before



burning to ashes. The woods were separately burnt in open air. Ashes produced were collected in plastic bags and taken to the laboratory for storage and subsequent analysis to determine their mineral contents. Use of fuel for burning was avoided to minimize contamination. Four experimental diets were formulated and designated as Control, NWA, The initial live weights of the birds were taken at the beginning of each experiment and at weekly intervals thereafter. Feed intake, weight gain and feed conversion ratio were determined according to the procedures of McDonald *et al.* (2011).

This was conducted on the 23<sup>rd</sup> and 49<sup>th</sup> day of the experiment using total collection technique according to the procedure of Aduku and Olukosi (1990). Two birds were randomly selected from each replicate and kept in the constructed metabolic cages. Activities involved feeding the broilers with known quantity of feed after allowing three days of acclimatization, followed by four days total faecal collection from each replicate. Faeces were bulked thoroughly mixed and sub-sample taken at the end of the faecal collection. The faeces were weighed and oven dried at 85 °C until a constant weight was obtained, followed by grinding to a size that could pass through a 2 mm sieve for proximate analysis. The difference between the nutrients in the Feed and faecal sample multiply by 100 gives the apparent digestibility coefficient of the feed in feed

Digestibility coefficient =  $\frac{\text{Nutrient in Feed Intake} - \text{Nutrient in dropping voided}}{\text{Nutrient in Feed Intake}}$  (Aduku and Olukosi, 1990)

#### Chemical Analysis

Feed and faecal sample of the diet were oven dried until a constant weight is attained. Both the diet as well as the faeces collected from each animal per replicate was chemically analysed according to AOAC (2000) procedure.

#### Statistical analysis

All data collected on growth performance and

SWA and LWA, respectively. Diet 1 was designated as the control without wood ash while diets 2, 3 and 4 contained 2 % NWA, SWA and LWA, respectively. The wood ash in diets 2, 3 and 4 were used to replace limestone and bone meal which were used in the control diet. The diet compositions of the two phases of the work are shown in Table 1. nutrient digestibility were subjected to one-way analysis of variance (ANOVA) using SAS version 9.2(SAS, 2013). Where means were significantly different at 5% ( $p < 0.05$ ), they were separated using Duncan Multiple Range Test.

## RESULTS AND DISCUSSION

The results showed that at the starter phase the dietary treatment had effect on the final weight, body weight gain and feed intake (Table 2). The wood ash treatments showed superior results that the control diets with the birds on STA diet performed better ( $P < 0.05$ ) than the control treatment.

The present results indicate that the final weight has no trend. The results showed that the final weight is higher in birds fed STA compared to other treatment, it also indicates that all experimental treatments had similar value compare to the control. However, birds on STA diet had the highest final weight gain. The present result is in agreement with the findings reported by Atuhene (1998) who reported that inclusion of Shea Butter Cake (SBC) up to 2.5% in growing broiler diet have no adverse effect on the growth performance.

Feed intake have similar trend with to the body weight gain. The results indicate that birds on STA had higher performance in term of feed intake, and weight gain. However, all dietary treatments performed better than the control. The high weight gain recorded could be as a result of feed intake. That decreased in weight gain in the control diet could be attributed to the fact that weight gain in broiler is directly related to feed intake, the quantity of feed as well as how efficiently the bird utilized it. The differences between the experimental diets and the control may be attributed to different source of mineral and the medicinal properties of the wood-ashes. The higher good performance of the experimental diets is in agreement with report of Saccomani *et al.* (2016) who started that firewood ash may be employed as calcium source in

replacement of limestone in broiler diet at starter phase (1 to 21 days of age) as it promotes similar performance and bone development as limestone.

Similarly, at the finisher phase, dietary treatments had effect ( $P < 0.05$ ) on the final and daily body weight gain. However, unlike the starter phase, dietary treatment had effect on the feed conversion ratio (Table 3). All the birds on the wood ash-based diets had similar results. Their results were better than those of birds on the control diet. The better performance might be attributed to better absorption of the mineral present in the wood ashes. Okoli *et al.* (2014) indicated that minerals in the ash are easily absorbed by the animal. Contrary to the finding in the present study, Onimisi *et al.* (2014) observed no difference in the growth performance of birds fed different calcium sources. This might be because the authors worked on only calcium and not with the other minerals present in the wood ash such as phosphorus, potassium, aluminium, magnesium, sodium, boron, copper, molybdenum, sulphur and zinc. (Theo Van Kempen, 2002). Furthermore, the similarity in the results of the different wood ashes used might implies that any of the ashes can be substitute for the other and they contained similar minerals. From FCR results, birds on shea butter ash had the highest FCR, the reasons is not well known; it, however, could be due to the fact that shea butter tree is rich in saturated and unsaturated fatty acids with a large fraction of unsaponifiable triglycerides, oleic acid, triterpene alcohols, vitamin E, provitamin A, allantoin (Hall *et al.*, 1996). The results of FCR agree with that of Okoli *et al.* (2014), who reported very high feed efficiency in pullets fed plantain ash supplemented diet.

In term of nutrient digestibility, birds on control, NTA, and LTA diets had higher ( $P < 0.05$ ) dry matter, ether extract digestibility compared to birds on STA diet at the starter phase. However, at the finisher phase birds on locust bean ash had better crude fibre and ash content digestibility, it might be due to the fact that locust bean tree is very rich in protein, vitamin C, retinol, calcium, crude fibre (Gernah *et al.* 2005; Ogundun, 2007). It could be because of the elevated mineral content present in locust bean wood ash as compared to shea butter wood ash (Alves *et al.* 2002). Storage, handling, processing procedure and anti-nutritional factor, combustion system and handling of the wood may also be contributing factors (Okoli *et al.* 2014). The results of growth performance showed that the wood ash based diets had effect on the daily weight gain, final weight and feed conversion ratio (FCR) of broiler chickens at finisher phase with birds on the wood ash diets performing better than the control. Wood ash based diets had effect on ash and crude fibre, with the birds of locust bean ash having high digestibility.

#### **CONCLUSION AND RECOMMENDATIONS**

From the results of this study, it can be recommended to both small and large scale farmers that any of these wood ash sources (neem tree, shea butter tree and locust bean tree) could be an effective substitute for feed lime stone and bone meal in supplying minerals in poultry diets since wood ash is rich in calcium and easily absorbed, it can be used also to supplement deficiencies in diets that contain ingredients known to be deficient in calcium.

**Table 1. Ingredients and chemical composition of experimental diet**

Starter phase Ingredients	Finisher phase							
	Control	NWA	SWA	LWA	Control	NWA	SWA	LWA
Maize	50.00	50.00	50.00	50.00	62.00	62.00	62.00	62.00
Maize bran	9.00	9.00	9.00	9.00	5.00	5.00	5.00	5.00
GNC	26.00	26.00	26.00	26.00	20.00	20.00	20.00	20.00
Fish meal	2.00	2.00	2.00	2.00	2.00	2.00	2.00	2.00
SBM	8.00	8.00	8.00	8.00	6.00	6.00	6.00	6.00
Bone meal	2.00	1.00	1.00	1.00	2.00	1.00	1.00	1.00
Limestone	2.00	1.00	1.00	1.00	2.00	1.00	1.00	1.00
Wood ash	0.00	2.00	2.00	2.00	0.00	2.00	2.00	2.00
Methionine	0.25	0.25	0.25	0.25	0.25	0.25	0.25	0.25
Lysine	0.25	0.25	0.25	0.25	0.25	0.25	0.25	0.25
Premix	0.25	0.25	0.25	0.25	0.25	0.25	0.25	0.25
Salt	0.25	0.25	0.25	0.25	0.25	0.25	0.25	0.25
<b>Total</b>	<b>100</b>	<b>100</b>	<b>100</b>	<b>100</b>	<b>100</b>	<b>100</b>	<b>100</b>	<b>100</b>
<b>CP (%)</b>	<b>22.35</b>	<b>22.35</b>	<b>22.35</b>	<b>22.35</b>	<b>19.39</b>	<b>19.39</b>	<b>19.39</b>	<b>19.39</b>
<b>ME (Kcal/Kg)</b>	<b>2934.00</b>	<b>2934.00</b>	<b>2934.00</b>	<b>2934.00</b>	<b>2939.00</b>	<b>2939.00</b>	<b>2939.00</b>	<b>2939.00</b>

NTA: Neem tree ash LTA:

Locus beans tree ash STA:

Shear butter tree ash



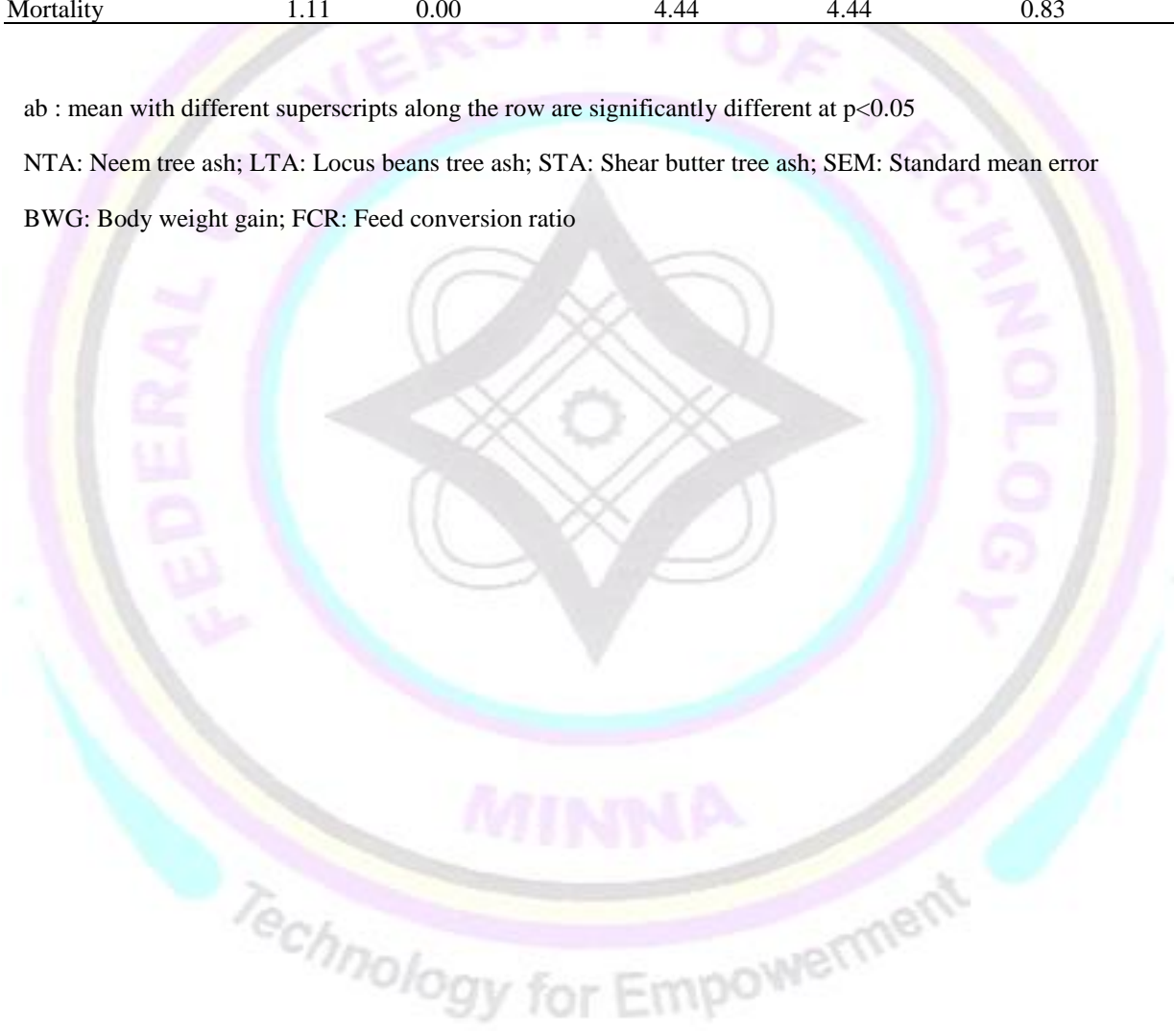
**Table 2. Effects of wood-ash based diet on growth performance of broiler chicken at starter phase.**

Parameters	Control	NTA	STA	LTA	SEM
Initial weight	57.67	61.00	62.00	63.00	1.18
Final weight	283.67 <sup>b</sup>	330.00 <sup>ab</sup>	366.00 <sup>a</sup>	318.67 <sup>ab</sup>	12.29
BWG	129.33 <sup>b</sup>	153.90 <sup>ab</sup>	173.71 <sup>a</sup>	144.52 <sup>ab</sup>	6.67
Feed intake	447.27 <sup>b</sup>	535.42 <sup>a</sup>	546.03 <sup>a</sup>	498.95 <sup>ab</sup>	15.62
FCR	3.46	3.48	3.27	3.50	0.08
Mortality	1.11	0.00	4.44	4.44	0.83

ab : mean with different superscripts along the row are significantly different at  $p < 0.05$

NTA: Neem tree ash; LTA: Locus beans tree ash; STA: Shear butter tree ash; SEM: Standard mean error

BWG: Body weight gain; FCR: Feed conversion ratio



**Table 3 Growth performance of broiler chicken fed diets containing different wood ash based diets at the finisher phase**

Parameter	NOA	NTA	SBA	LBA	SEM
Initial weight (g)	286.33	330.00	276.67	316.67	11.43
Final weight (g)	959.17 <sup>b</sup>	1238.15 <sup>a</sup>	1197.38 <sup>a</sup>	1155.95 <sup>a</sup>	37.86
Daily Weight gain (g)	24.03 <sup>b</sup>	32.43 <sup>a</sup>	32.88 <sup>a</sup>	29.97 <sup>a</sup>	1.27
Average daily Feed intake (g)	88.41	95.04	92.63	93.76	2.24
FCR	3.68 <sup>b</sup>	2.93 <sup>a</sup>	2.84 <sup>a</sup>	3.13 <sup>a</sup>	0.12
MORT (%)	13.33	13.33	16.67	16.67	3.59

**ab=means on the same row bearing different superscript are significantly different (p<0.05) NOA=No ash (control)**

**NTA=Neem tree ash SBA=Shea butter ash LBA=Locust bean ash NFE=Nitrogen free extract FCR=feed conversion ratio**

**MORT=Mortality SEM=Standard error of mean**



**Table 4. Effects of wood-ash based diets on nutrient digestibility of broiler chicken at starter phase.**

Parameters	Control	NTA	STA	LTA	SEM
Dry matter	64.53 <sup>a</sup>	65.03 <sup>a</sup>	55.96 <sup>b</sup>	65.73 <sup>a</sup>	1.71
Ether extract	76.45 <sup>a</sup>	75.59 <sup>a</sup>	57.41 <sup>b</sup>	70.23 <sup>b</sup>	3.18
Ash	15.69	20.73	4.29	19.15	3.86
Crude protein	66.42	63.72	53.83	64.56	2.42
Crude fibre	23.63	28.15	20.90	23.33	1.64
NFE	76.47	75.62	80.55	78.86	0.88

ab: mean with different superscript are significantly different ( $p < 0.05$ ) NTA: Neem tree ash LTA: Locust bean tree ash STA: Shea butter tree ash





**Table 5. Nutrient digestibility of broiler chickens fed diets containing different wood ash-based diets at the finisher phase**

Parameter	NOA	NTA	SBA	LBA	SEM
Dry matter (%)	90.74	90.88	90.79	91.44	0.21
Crude protein (%)	91.04	93.12	92.46	90.94	0.62
Crude fibre (%)	38.62 <sup>c</sup>	58.81 <sup>b</sup>	53.79 <sup>b</sup>	79.87 <sup>a</sup>	5.63
Ether extract (%)	92.63	92.59	92.11	93.59	0.67
Ash content (%)	65.80 <sup>ab</sup>	64.05 <sup>ab</sup>	52.13 <sup>b</sup>	69.56 <sup>a</sup>	2.96
NFE (%)	97.61	95.35	96.90	96.65	0.44
Gross energy (%)	92.26	91.51	91.72	91.81	0.35

abc=means on the same row bearing different superscript are significantly different ( $p < 0.05$ ) NOA=No ash (control)

NTA=Neem tree ash

SBA=Shea butter ash

LBA=Locust bean ash

NFE=Nitrogen free extract

CP=Crude protein EE=Ether

extract

## REFERENCES

- Adamu, S. B., Geidam, Y. A., Mohammed, G., Gambo, H. I. and Raji, A. O. (2012). The influence of varying calcium-phosphorus ratios on finishing and carcass characteristics of broiler finisher chickens under a semi-arid environment. Asian Research Publishing Network. *Journal of Agricultural and Biological Science*, (7), (7), 1990-6145.
- Aduku, A. O. and Olukosi, J. O. (1990). Rabbit management in the tropics: production, processing, utilization, marketing, economics, practical training, research and future prospect. *Living book series*. Abuja, FCT. GU publisher: pp 111.
- Alves, E. L., Teixeira, A. S., Bertechini, A. G., Rodrigues, P. B. and Oliveira, A. I.G. (2002). Effect of calcium levels in two sources on the performance of broiler chickens. *Science and Agrotechnology*, 26, (6), 1305-1312.
- AOAC (2000). *Official Methods of Analysis. 17th edition*. Association of Official Analytical Chemists, Arlington, DC.
- Araujo, C. S. S., Artoni, S. M. B., Araujo, L.F. and Borges, S. A. (2002). Avaliação e desempenho e excreção de cálcio em duas linhagens de frangos de corte, na fase inicial, alimentados com diferentes níveis de aminoácidos e de cálcio. *Revista Brasileira de Ciência Avícola*, 4, 111-118.
- Atuahene, C. C., Donkoh, A. and Asante, F. (1998). Value of sheanut cake as a dietary ingredient for broiler chickens. *Animal Feed Science and Technology*, 72: 133-142.
- Costa, F. G. P., Brandao, P. A., Silva, J. H. V., Lima-Neto, R. C., Goulart, C. C. and Pereira, W.E. (2009). Calcium requirements for female Japanese quails from one to 35 days of age. *Acta Scientiarum Animal Science*, 31, (1), 7-12.
- Garner, J. P., Falcone, C., Wakenell, P., Martin, M. and Mench, J. A. (2002). *British Poultry Science*, 43, 355-363.
- Gernah, D.I., Atolagbe, M.O. and Echegwo, C.C. (2007). Nutritional Composition of the African Locust Bean (*Parkia biglobosa*) fruit pulp. *Nigerian Food Journal*, 25 (1), 190 - 196.
- Hall JB et. al. 1996. *Vitellariaparadoxa: a monograph*. School of Agriculture and Forest Sciences, University of Wales, Bangor.
- Henry, M. H. and Pesti, G. M. (2002). An investigation of calcium citrate-malate as a calcium source for young broiler chicks. *Poultry Science*, 81, 1149-1155.
- McDonald, P., Edwards, R.A., Greenhalgh, J.F.D., Morgan, C. A., Sinclair L.A. and Wilkinson R.G. (2011). *Animal Nutrition*. Seventh edition. Prentice Hall. London.
- Ogundun, N.J. (2007). Replacement of maize with locust bean seed as energy sources in the diet of rabbit. 32 NSAP conf. Unical. 18th - 21st March, 455-456.
- Okoli, I.C., Ngowu, C.M., Etuk, I.F., Omede, A.A., Ogbuewe, I.P., Aladi, N.O., Okoro, V.M.O., Opara, M.N., Zema, C.E., Uchegu, M.C., Ekenyem, G.A., Anyanwu, N.J., Okeudo, A.B. I. Udedibie, and Madubuike, F.N. (2014). Plantain ash enhances dietary mineral elements absorption in pullets. *Asian Journal of Animal Science* 4(2): 351-360.
- Onimisi P. A., Dafwang, I. I. and Bishop B. (2014). Effects of calcium and phosphorus sources on growth performance and bone mineralisation of broiler chickens raised in

- the Nigerian environment. *Nigerian Poultry Science Journal*, 11.
- Ovimaps (2016). Ovi location map; Ovi Earth Imager.
- Pelicia, K., Mourao, L., Garcia, E.A., Pinheiro, V.N.C., Berto, D.A., Molino, A.B., Faitairone, A.B.G., Vercese, F., Santos, G.C. and Silva, A. P. (2011). Effects of dietary calcium levels and limestone particle size on the performance, tibia and blood of laying hens. *Brazilian Journal of Poultry Science*, 1, (1), 29-34.
- Sa, L. M., Gomes, P. C., Albino, L. F. T., Rostagno, H. S. and D'Agostini, P. (2004). Exigência nutricional de cálcio e sua biodisponibilidade em alguns alimentos para frangos de corte, no período de 1 a 21 dias de idade. *Revista Brasileira de Zootecnia*, 33, 157-168.
- Saccomani, A. P. O., Faria-Filho, D.E., Franca, X.A.A., Dias, A.A. and Matos-Junior, J.B. (2016). Firewood ash as calcium source in the initial diet of broiler chickens. *Brazilian Journal of Poultry Science*, 18, (4), 645-648.
- Santos, L. M., Rodrigues, P. B., Freitas, R. T. F., Bertechini, A. G., Fialho, E. T. and Gomide. (2011). Calcium and phosphorus levels available in phytase diets for broilers in the pre-initial and early stages. *Revista Brasileira de Zootecnia*, 40 (11): 2476-2485.
- SAS (2013) - Statistical Analysis System Institute. Statistical analysis user's guide. Version 9.2 Cary; NC.
- Talpur, M., Rind, M., Memon, A. and Ujjan N. (2012). Effect of Dietary calcium on the performance of commercial chicken. *Journal of Veterinary and Animal Science*, 2, 101-106.
- Tancharoenrat, P. and Ravindran, V. (2014). Influence of tallow and calcium concentrations on the performance and energy and nutrient utilization in broiler starters. *Poultry Science*, 93, 145-146.
- Theo Van Kempen (2002). Ultimate Recycling: Ash from combustion of swine manure used as a mineral source for pigs. North Carolina cooperative extension service. *Swine husbandry*, 25 (9), 4-6.
- Underwood, E.J. and Suttle, N. F. (2001). The mineral nutrition of livestock. 3rd edition. Wallingford: CAB International.
- Vahid, R., Aliakbar, P. A. and Masomeh, N. (2014). Growth performance, tibia characteristics, immune response and blood metabolites of Broiler chickens fed diets containing Citrus Brown Snail (*Caucasotachea Lencoranea*) Powder as a Source of Calcium. *International Journal of Advanced Biological and Biomedical Research*, 2, (8), 2495-2504.



## AN ASSESSMENT OF FARMERS AWARENESS AND PERCEPTION ON USE OF SOIL INFORMATION IN NIGER STATE

Abdurasak<sup>1\*</sup>, Y. L., B. A. Lawal<sup>1</sup>, B. A. Raji<sup>2</sup>., M. Yakubu<sup>3</sup>., A. A. Panti<sup>4</sup>

<sup>1</sup>Department of Soil Science and Land Management, Federal University of Technology Minna, P.M.B 65, Minna, Niger State. Nigeria

<sup>2</sup>Department of Forest Resources Management, University of Ilorin, P.M.B 1515, Ilorin, Kwara state. Nigeria

<sup>3</sup>Department of Agricultural Extension and Rural Development, Federal University of Technology Minna, P.M.B 65, Minna, Niger state. Nigeria

<sup>4</sup>Niger State Agricultural and Mechanization Development Authority (NAMDA), Maitumbi, Minna. Niger state. Nigeria

\*Corresponding Author's E-mail: [yusuflayi@gmail.com](mailto:yusuflayi@gmail.com) GSM: [08157035105](tel:08157035105)

### ABSTRACT

*The study farmers awareness and perception about use of soil information in Niger state. Multi stage sampling technique was used to select 120 respondents within the three agricultural zones of the state for the study. Data for the study were collected using a structured questionnaire. Descriptive statistics was used to analyse the data. The result revealed 99.2 % of the respondents know about soil information with 64.2 % introduced to soil information by extension agents. Majority of the respondents were not aware of the importance and use of soil information, with the mean level of awareness of farmers towards soil information was low with an average of 1.78. Majority of the respondents agreed with the notion that soil information can increase productivity and lead to sustainable agriculture, with the mean level of agreement revealed to be high with an average of 3.64. The respondents disagreed with the notion that soil information is needed for only large-scale farming. The study also revealed that 66.7 % of the respondents locally classify their soils in the study area as a form of soil information, using topsoil physical characteristics such as soil colour, soil weight and feel as indicators for classification. The respondents were not aware of the importance of soil information, but are willing to adopt the use of soil information, if more awareness programs and reduced cost of soil analysis are in place.*

**KEYWORDS:** Soil information, Local classification, Sustainable agriculture.

---

### INTRODUCTION

Soil plays a major role in the quality of our environment. It is the foundation for food and fibre production. Knowledge of soil is required for land use planning activities and the decision of what use a particular soil type could be assigned. Moreover, understanding of soil properties and processes is important in evaluating the criteria for soil management and cultivation and agricultural production.

Esu (2004), Lekwa *et al.* (2004), Ogunleke (2004), Fasina *et al.* (2007), Lobry de Bruyn and Andrew (2016), noted that increase in demand and lack of information on soils contribute to the problem of soil degradation and world food crises, due to the wrong use and poor management of land resources. With existing soil information sources and soil characterization basic information can be provided to assess soil fertility in order to resolve soil problems in an ecosystem and help in the world food crisis.

Onyekanne (2012), Achukwu *et al.* (2013), Sharu *et al.* (2013) stated that for sustainable land management, information on the soil resources and how to manage them is needed and this is achieved through characterization, classification and evaluation of the soil. Romig *et al.* (1995), Liebig *et al.* (1995) and Lobry de Bruyn and Abbey (2003), Lobry de Bruyn and Andrews (2016) all noted that there are a lot of barriers to collecting and acting on soil information, with majority of farmer's soil-information poor, or at least they are not informed as to the condition of their soil by soil testing, which highlights those soils which are at risk of land degradation. Increasing farmers access to the use of soil information means engaging farmers more directly with existing soil information resources (Lobry de Bruyn and Andrews, 2016). A challenge to agricultural production is that farmers, in particular small-scale farmers, do not know the status of their soils. The ability to have data that can move across

states and borders are vital for the agricultural sector in today's global market environment (FAO, 2017), the only way agricultural production can be sustained is when farmers can assess adequate and accurate data.

In Nigeria there is a lack of collection and management of agricultural data and inadequate data in agriculture will hinder foreign direct investment and governments efforts to reform the agricultural sector, since quality data improves both sectoral benefits and real economic benefits (Essiet, 2015). In Nigeria, like most developing countries, one primary constraint to sustainable and successful agricultural program, is lack of knowledge about the soil resources and how to manage them (Achukwu *et al.*, 2013). Boonsompopphan *et al.* (2008) noted that with the ability of farmers to identify soil series farmers could obtain site-specific nutrient recommendations and as a result of applying site-specific nutrient management, farmers have reduced their fertilizer use while maintaining yields and thus increased profit and reduced excessive fertilization. In Minna, there have been wide spread survey of the soil, documenting the fertility status in conjunction with management practices which can improve the soil fertility and reduce soil degradation. However, these recommendations have majorly not been adopted by farmers, with the reason for this basically being the lack of knowledge and information by the farmers. Also, there has been lack of knowledge of the perception of farmers towards soil data and their willingness to use the data presented to them, which might have led to bridging the gap between researchers and farmers. Since, there have been few studies in Minna, that document farmers view on soil data and their utilization. The study was therefore designed to identify how soils are classified, assess the level of awareness, perception and use of soil information by farmers in crop production in Niger State, Nigeria.

## METHODOLOGY

The study was carried out in the three agricultural zones of Niger State, Nigeria. It lies between longitude 6° 25' E and 6°45' E and Latitude 9°24' N and 9°48' N and is at an elevation of 299 m above sea level. Niger falls under the Southern Guinea Savanna agro-ecological zone of Nigeria, the climate of Minna is sub-humid with mean annual rainfall of 1284 mm and a distinct dry season of about 5 months duration occurring from November to March (Ojanuga, 2006). The mean maximum temperature remains high throughout, about 33.5° C, particularly in March and June (Ojanuga, 2006). The soils of the study area are grouped under the Southern belt of forest soils which have underlying rocks of granite or clay, with

soils rich in clay loam, and zone of alluvial soils which are fresh - water soil of grey to white sand, grey clay and sandy clay with humic topsoil (Oyenuga, 1967; Iloeje, 2001). The soils are generally low in organic matter, total nitrogen and available phosphorus with high erodibility, are structurally weak, coarse textured with low organic matter status (Ahmakhian and Osemwota, 2012).

A multi-stage sampling technique was used to select the respondents for the study. Stage one involved random selection of one (1) Local Government Area from each agricultural zone, stage two (2) was random selection of two (2) villages from each Local Government Area. Stage three (3) was random selection of twenty (20) rural farmers from each village to give 120 respondents for the study. Primary data was collected with the use of structured questionnaire, complimented with an interview schedule. Data collected was analyzed using descriptive statistics such as mean, standard deviation, pie chart, bar chart, percentages and frequency distribution as appropriate. Attitudinal measuring scale like likert rating scale was also used to categorize the respondent responses into 3-point and 5-point likert rating scale. The research methodology used was the quantitative method of data collection, this provided general understanding of the research problem and generated empirical evidence that could be used to answer research questions. This quantitative data was collected with the use of primary data. The data was obtained through the use of structured questionnaires, with simple random sampling procedure being utilized in selection of respondents in order to be a representative sample of the population.

## RESULTS AND DISCUSSION

### Institutional characteristics

Table 1 shows that majority of the respondents (52.5 %) are permanently practising agriculture with 28.3 % utilizing trading as a secondary occupation. The table shows that (73.3 %) of the farmers belong to a cooperative society and (46.7 %) having access to agricultural credit majorly through agricultural banks (44.2 %), although the amount of credit is low which has little impact on increase in productivity. This is accordance with Odoemenem *et al.* (2010) who stated that productivity and growth of agriculture is hindered by limited access to credit facilities. The table also shows that (99.2 %) of the farmers have contact with agricultural extension agents, with frequency of the contact majorly bi-weekly (42.5 %), which may lead to higher rate of adoption of information and new technologies. This is accordance with Shehu *et al.* (2016) who noted that farmers who had more contact with extension agents are more than



two times likely to adopt modern technology than those with no access to extension agents. Majority (99.2 %) of the respondents know about soil information. This may be due introduction by extension agents, since the framers have a high level of contact with extension agents. Majority of the respondents (64.2 %) were introduced to soil information by extension agents and 57.5 % of the respondents use a form soil information, while carrying out farming activities.

#### **Awareness of farmers to soil information**

Table 2 shows the awareness of farmers about soil information in the study area. Awareness about soil information (1.98), awareness on use of soil information (1.93) and awareness that soil information improves yield (1.79) were the statements the farmers were most aware about. All the mean scores were less than 2.00 indicating they are generally not aware of all the statements on table 4. This may imply that most farmers do not use standard soil information for farming. Okunola (2009) stated that awareness is the first stage of adoption before respondents develop interest in the technology and later decide on adoption.

#### **Farmers perception about soil information**

Table 3 shows the perception of farmers towards soil information. Improvement of yield (3.98), improvement of soil fertility (4.20), encouragement to farm (3.86), lack of knowledge on soil information (3.83) and high cost of soil analysis (3.71) were the statements the respondents majorly agreed upon with the mean scores above 3.00. This means that if farmers are educated about soil information, they are able to understand, utilize and transfer soil information to other farmers. This is similar to the findings of Duruiheoma *et al.* (2015) who stated that highly aware farmers aid in transferring knowledge between older farmers and farm owners, through a possible knowledge transfer network, where knowledge about soils are shared.

The farmers majorly disagreed with the perception that soil information is only necessary for large scale farming (2.14), which may mean farmers are willing to adopt use of soil information in their farming activities if made available to them, with reduced cost of soil analysis being the incentive they require.

#### **Barriers limiting use of soil information**

Table 4 shows the constraints faced with by the farmers on the use of soil information. The result showed that lack of awareness on actual importance of soil information (99.2 %), lack of understanding of soil information (93.2 %), inadequate extension service (83.3 %), language barrier (80.8 %) and high

cost of accessing soil information (72.5 %) the major barriers the farmers believe affect their adoption of soil information. This showed that farmers are willing to accept the use of soil information, if they are properly educated on soil information through the proper channels and they are made accessible.

#### **Solutions to barriers**

Table 5 shows the possible solutions suggested by the farmers that can aid them in utilizing soil information. Majority of the farmers stated that more awareness programs on soil information (64.2 %) will help them understand the use and importance of soil information. They also stated that Reduced cost of soil analysis (52.5 %) will encourage them to utilize soil information, with farmers stating that if the price is affordable they are willing to pay for soil analysis. The farmers also suggested to be giving more access to soil information (44.2 %) with most claiming that even though they have heard of soil information they have been taught how and where to access such information. Also 25% of the farmers believed that extension agents should be trained on soil information and should help in soil analysis, since the extension agents only introduced them to soil information but did not state its importance to them. This might be due to the fact most extension agents are trained in agriculture which does not give them enough knowledge on soil information. Kufoniyi (2000) and Okedi (2000) stated that a well trained extension worker in soil information can transform such complex soil data to customized or user-friendly forms.

#### **CONCLUSION AND RECOMMENDATIONS**

The result of this research showed that majority of the farmers have been introduced to soil information but not all use it for farming. Even though, they were introduced to soil information there is a gap in knowledge regarding the relevance and use of soil information, due to the fact that extension agents did not disseminate such information to the farmers. The farmers also agree with the notion that soil information can increase agricultural productivity and bring about sustainable agriculture, although this depends on the availability of soil information to them in terms of reduced cost of soil analysis and more awareness programs. Most of the farmers classify their soils locally as a form of soil information and this serves as a means of selecting specific crops to suit specific crop types, although there is a gap between scientific classification of soils and local classification with local classification only taking into consideration the colour and texture of the soil, linkage between farmers, extension agents and soil scientist can bridge the gap in classification



allowing for farmers to in-cooperate more parameters

into their form of classification.

**Table 1: Institutional characteristics of respondents**

<b>Variables</b>	<b>Frequency</b>	<b>Percentage</b>
<b>Secondary occupation</b>		
Farming	63	52.5
Trading	34	28.3
Civil servant	2	1.7
Processing	21	17.5
<b>Total</b>	120	100.0
<b>Cooperative Membership</b>		
Yes	88	73.3
No	32	26.7
<b>Total</b>	120	100.0
<b>Access to credit</b>		
Yes	56	46.7
No	64	53.3
<b>Total</b>	120	100.0
<b>Source of Credit</b>		
None	58	48.3
Agricultural bank	53	44.2
Cooperative	9	7.5
<b>Total</b>	120	100.0
<b>Extension Contact</b>		
Yes	119	99.2
No	1	0.8
<b>Total</b>	120	100.0
<b>Frequency of Contact</b>		
Weekly	28	23.3
Bi-weekly	51	42.5
Monthly	41	34.2
<b>Total</b>	120	100.0
<b>Introduction to Soil information by extension agents</b>		
Yes	77	64.2
No	43	35.8
<b>Total</b>	120	100.0
<b>Knowledge about soil information</b>		
Yes	119	99.2
No	1	0.8
<b>Total</b>	120	100.0
<b>Usage of soil information</b>		
Yes	69	57.5
No	51	42.5
<b>Total</b>	120	100.0
<b>Use of local soil classification</b>		
Yes	80	66.7
No	40	33.3

**Total**

120

100

Source: Field survey, 2018

Table 2: Awareness of respondents about soil information

<b>Statements</b>	<b>HA</b>	<b>A</b>	<b>NA</b>	<b>WS</b>	<b>WM</b>	<b>Decision</b>
Awareness about soil information	0	118	2	238	1.98	Not aware
Awareness of use of soil information	0	112	8	232	1.93	Not aware
Awareness on importance of soil information	9	49	62	187	1.56	Not aware
Awareness that soil information improve yield	23	49	48	215	1.79	Not aware
Awareness that soil information improves fertility	13	61	46	207	1.73	Not aware
Awareness that soil information reduces cost of production	11	66	43	208	1.73	Not aware
Awareness that soil information reduces soil deterioration	14	61	45	209	1.74	Not aware

HA = Highly aware, A = Aware, NA = Not aware, WS = Weighted sum, WM =Weighted mean.

Table 3: Perception of respondents about soil information

<b>Statement</b>	<b>SA</b>	<b>A</b>	<b>UD</b>	<b>D</b>	<b>SD</b>	<b>WS</b>	<b>WM</b>	<b>Decision</b>
Soil information improves yield	0	118	2	0	0	478	3.98	Agree
Soil information improves soil fertility	27	90	3	0	0	504	4.20	Agree
Soil information is necessary for agricultural production	22	51	43	4	0	451	3.76	Agree
Soil information encourages people to farm	30	45	43	2	0	463	3.86	Agree
Soil information reduces soil deterioration	16	35	68	1	0	426	3.55	Agree
Soil information is only necessary for large scale farming	0	0	18	101	1	257	2.14	Disagree
Soil information reduces stress	1	72	47	0	0	434	3.62	Agree
Soil information is too expensive	0	85	35	0	0	445	3.71	Agree
There is lack of knowledge on soil information	4	93	22	1	0	460	3.83	Agree
Inadequate information on soil information	5	76	38	1	0	445	3.71	Agree

SA = Strongly agree, A = Agree, UD = Undecided, D = Disagree, SD = Strongly disagree, WS = Weighted sum, WM= Weighted mean.

Table 4: Barriers limiting use of soil information

<b>Barriers</b>	<b>Frequency</b>	<b>Percentage</b>	<b>Rank</b>
Lack of awareness on soil information	119	99.2	1
High cost of accessing soil information	87	72.5	5
Unreliability of soil information	57	47.5	9
Lack of understanding of soil information	112	93.3	2
Change in soil fertility	83	69.2	6
Land tenure problem	65	54.2	8
Lack of subsidy for soil information	68	56.7	7
Inadequate extension service	100	83.3	3
Language barrier	97	80.8	4

Source: Field survey, 2018

Table 5: Solutions to barriers

<b>Solutions</b>	<b>Frequency</b>	<b>Percentage</b>	<b>Rank</b>
Reliable soil information	11	9.2	6
More awareness programme	77	64.2	1
Extension agents aiding in soil analysis	30	25	5
Reduced cost of soil analysis	63	52.5	2
Access to soil information	53	44.2	3
Training of extension agents on soil information	30	25	4

Source: Field survey, 2018

## REFERENCES

- Achukwu, E. M., Raji, B. A., & Lya, U. S. (2013). Compilation Of Existing Soil Series In North-Eastern Nigeria: Problem And Prospect. *Nigerian Journal of Soil Science*, 23(2): 189-195.
- Amhakhian, S. O., & Osemwota, I. O. (2012). Physical and Chemical Properties of Soils in Kogi State, Guinea Savanna Zone of Nigeria. *Nigerian Journal of Soil Science*, 22(1): 44-53.
- Boonsompopphan, B., Vearasilp, T., Yost, R. S., & Attanandana, T. (2008). Field Identification of Soil Series: Indexing and Retrieving Soil Information While Sharing Experience and Knowledge. (*Soil Science*; 173(10): 736–744) Lippincott Williams & Wilkins, Inc.
- Duruiheoma, F. I., Burek, C. V., & Alexander, R. (2015). Farmers perception of soil: implications for soil conservation and susustainable agriculture in the UK. *European centre for research training and development UK* 3(3): 11- 24.
- Essiet, D. (2015) Combating challenges of poor data-driven agriculture Retrieved:01/05/18 <http://thenationonline.net/combating-challenges-of-poor-data-driven-agriculture/>
- Esu I. E. (2004). Soil Characterization and Mapping for Food Security and Sustainable Environment in Nigeria: In Proceeding of the 29th Annual Conference of The Soil Science Society of Nigeria. 10-16Pp.
- FAO (2017). Food and Agricultural Organization, FAO in Nigeria: Nigeria improve data collection on agriculture <http://www.fao.org/Nigeria/news/detail-event/en/c/891622/> retrieved 01/05/2018
- Fasina, A. S., Omolayo, F. A., Ajayi, S. O., & Falodun, A. A. (2007). Influence of Land Use on Soil Properties in Three Mapping Units in Southwestern Nigeria-Implications for Sustainable Soil Management. In Uyovbisere, E.O, Raji, B.A, Yusuf, A.A, Ogunwale, J.O, Aliyu, L. and Ojeniyi, S.O (Eds). *Soil and water management for poverty alleviation and sustainable Environment* Proceedings of the 31st annual conference. of SSSN/ABU Zaria Nig. Nov. 13th to 17th, 2006.
- Iloeje, N. P. (2001). A New Geography of Nigeria. New Revised Edition. Longman Nigeria PLC. 200Pp.
- Kufoniyi, O. (2000). Basic concepts in Geographic Information systems (GIS) In: Principles and Applications of GIS, Eziegbo C.U. (Ed.) Panaf Press. Lagos
- Lekwa, M. U., Anene, B. O., & Lekwa, G. (2004). Chemical and Morphological Soil Characteristics in Drainage Toposequence in Southeastern Nigeria. In Ojeniyi, S.O., Ano, A.O., Awasalam, D.O. and Chukwu, G.O. (Eds) *Land Degradation, Agricultural Productivity and rural poverty, environmental implications*. Proceedings of the 28<sup>th</sup> Annual Conference of the Soil Science Society of Nigeria, held at National Root Crops Research Institute, Umudike, Abia State. Nov. 2003, 4<sup>th</sup> – 7<sup>th</sup>, 316-322.
- Liebig, M. A., & Doran, J. W. (1995). Evaluation of farmers' perceptions of soil quality indicators. *American Journal of Alternative Agriculture*, 14: 11–21.
- Lobry de Bruyn, L. A., & Abbey, J. A. (2003). Characterization of farmers' soil sense and the implications for on-farm monitoring of soil health. *Australian Journal of Experimental Agriculture*, 43: 285–305.
- Lobry de Bruyn, L. A., & Andrews, S. (2016). Review Are Australian and United States Farmers Using Soil Information for Soil Health Management? *Sustainability*, 2016, 8(4): 304; doi:10.3390/su8040304 March 2016
- Odoemenem, I. U., and Obine, C. P. O. (2010). Assessing the factors that influence the utilization of improved cereal crop production technologies by small scale farmers in Nigeria. *Indian journal of science and technology*, 3(1): 180 – 183.
- Ogunleke, A. O., (2004). Soil Survey and Sustainable Land Management. Proceedings of the 29th Annual Conference of The Soil Science Society of Nigeria, December 6-10, 2004, University of Agriculture, Abeokuta, Nigeria, 12-16.
- Ojanuga, A. G. (2006). Agroecological Zones of Nigeria Manual. FAO/NSPFS, Federal Ministry of Agriculture and Rural Development, Abuja, Nigeria, 124 Pp.



- Okedi, J. Y. (2000). Information support for natural resource management policy formulation in Uganda. Proceedings of a CTA: Information support for hundred resource management policy CTA workshop, January 26 – 29, 2000, Wageningen, the Netherlands, 131 – 144.
- Onyekanne, C. F., Akamigbo, F. O. R., & Nnaji, G. U. (2012). Characterization and Classification of Soils of Ideato North Local Government Area. *Nigerian Journal of Soil Science*, 22 (1): 11- 17.
- Oyenuga, V. A. (1967). Agriculture in Nigeria. Food and Agriculture Organization of The United Nations). FAO, Rome, Italy. 308 Pp
- Romig, D. E., Garlynd, M. J., Harris, R. F. & McSweeney, K. (1995). How farmers assess soil health and quality. *Journal of Soil Water Conservation*, 50: 229–236.
- Sharu, M.B., Yakubu, M., Noma, S. S., & Tsafe, A. I. (2013). Characterization and Classification of Soils on An Agricultural Landscape in Dingyadi District, Sokoto State, Nigeria. *Nigerian Journal of Basic Applied Science*, 21: 137-147.
- Shehu, J. F., Gaya, A. S., Msheliu, S. I., and Adebayo, E. F. (2016). Determinants of innovativeness. The case study of smallholder rice farmers in North eastern Nigeria. In Nwachukwu, I. N., Amadi, C. O., Ewuziem, J. E., Okoye, B. C., Afuape, S. O, Agwu, N. M. and Oteh, O.U (Eds.) Economic dicersifiaction: the agricultural road map. Proceedings of 50<sup>th</sup> annual conference of agricultural society of Nigeria, Abia 2016, October 3 – 7, 2016, 157 – 160.

# ARTIFICIAL IMMUNE SYSTEM (AIS) ALGORITHMS FOR CROPS CLASSIFICATION USING PRINCIPAL COMPONENTS ANALYSIS

\*<sup>1</sup> Akinwande, O.T and <sup>2</sup> Abdullahi, M.B

Department of Computer Science, Federal University of Technology, Minna, Niger State, Nigeria

\*Email of Corresponding Author: [oladavoakinwande@yahoo.com](mailto:oladavoakinwande@yahoo.com) GSM: 07039146008

## ABSTRACT

*There have been tremendous increase in crop production data which can be used to characterize and predict models in data mining for agriculture. Recently, researchers have shown a lot of interest in applying biologically inspired systems for solving classification and recognition problems. Several solutions have been proposed using Artificial Immune System (AIS), Ant Colony Optimization and so forth in classification problems as another machine learning technique. The field of agriculture is not left behind in the use of machine learning technique for crop and soil classification but few research has been carried out in using AIS as a machine learning technique for crop edibility and disease classification. In this paper, we propose an Artificial Immune System (AIS) solution using AIRS, Clonal and Immunos algorithms with PCA for crop edibility and crop disease classification. The proposed solution is tested on two crop dataset (Mushroom and Soybeans dataset). The results show significant improvement of the proposed solution over other techniques in most of the cases. Accuracy, true positives and false positives were used as performance measures. The proposed model can be used to enhance crop productivity.*

**KEYWORDS:** Expert System, Artificial Immune System, Feature Extraction, Principal Components Analysis

## INTRODUCTION

The vast amount of data in the agricultural sector has make the application of machine learning technique in agriculture to be on the rise. Accurate prediction of crop production, classification of crop type and diseases detection in crops can be better analyzed with the use of machine learning techniques which are brought together by computer science and statistics.

Machine learning involves adaptive mechanism that enable computers to learn from experience, learn by example and learn by analogy. In machine learning techniques, knowledge is giving to the machine to learn some certain features in order to classify or make predictions that can be used for decisions. Supervised and unsupervised are two types of machine learning techniques (Subhdra et al ,2016). Over time, learning capabilities can improve the performance of an intelligent system. Neural networks, Bayesian networks and AIS are one of the popular approaches to machine learning.

In order to verify the effectiveness of different AIS classifiers algorithms on the combination of principal component analysis (PCA) as a preprocessing method for the crops production, we used mushroom and Soybeans dataset to make relevant experiments step-by-step. Firstly, we build the experiment evaluation environment with major steps: environment setup, data preprocessing, choosing the data mining software. Secondly, we select the three of most popular AIS classifier algorithms. An

overview of how specific values of these algorithms were identified as well as their classification performance is given. Finally, we come up with the performance comparison between the 3 selected classifiers with mushroom dataset and soybean dataset. The outcome of this AIS based mining model can be utilized for decision support in improving agricultural crops productivity.

The paper is organized as follows. The section 2 discussed some research work in the use of machine learning for crop classification. In section 3, the AIS algorithms are explained. Section 4 gives the description of the experiments and the methods used. The results obtained are discussed in section 5. Conclusion and future work is given in section 6.

## METHODOLOGY

As Classification problems is important in computing so it is in agriculture. For this work, we use Soybeans and Mushroom dataset. All testing are done on a Personal Computer (PC) Windows 8.1 Machine (Intel Pentium 2.4GHZ, 6 GB RAM). The software used for the evaluation was WEKA (Waikato Environment for Knowledge Analysis) and WekaClassalgos, an open source machine Learning workbench for artificial immune systems algorithms. WEKA has an extensive collection of pre-processing methods and Machine learning algorithms implemented in Java as classes with an optional

graphical user interface. WEKA Version 3.7.8 and WekaClassifiers 1.8 were used in this study.

### A. Artificial Immune System

The AIRS algorithm was one of the first AIS technique that is designed to tackle classification and recognition problems. The Artificial Immune Recognition System belongs to the field of Artificial Immune Systems, and more broadly to the field of Computational Intelligence. It was extended early to the canonical version called the Artificial Immune Recognition System 2 (AIRS2) and provides the basis for extensions such as the Parallel Artificial Immune Recognition System. It is related to other Artificial Immune System algorithms such as the Dendritic Cell Algorithm, the Clonal Selection Algorithm, and the Negative Selection Algorithm (Jason, 2012). The information processing objective of the technique is to prepare a set of real-valued vectors to classify patterns. The function of the AIRS algorithm is to prepare a pool of recognition or memory cells (data exemplars) which are representative of the training data the model is exposed to, and is suitable for classifying unseen data. In AIRS, clonal expansion and affinity maturation are used to encourage the generation of potential memory cells which are later used for classification. Hypothetically, AIRS has four stages to learning which are initialization, memory cell identification, resource competition and finally; refinement of established memory cells. The original AIRS1 algorithm uses a user defined *mutate rate* parameter to determine the degree to mutate a produced clone, and simply replaced attribute values with randomly generated values within the attributes normalised range. AIRS2 introduced the concept of somatic hyper mutation where the amount of mutation a clone receives is proportional to its affinity to the antigen in question (Jason,2012 ). Another important difference between AIRS1 and AIRS2 is the manner in which clones are mutated.

### 3.2 Clonal Selection Algorithm

The clonal selection algorithm (CLONALG) is actuated from the clonal selection theory. It is applied to optimization and pattern recognition problem. The clonal selection theory credited to Burnet was proposed to account for the behavior and capabilities of antibodies in the acquired immune system (). Inspired itself by the principles of Darwinian natural

selection theory of evolution, the theory proposes that antigens select-for lymphocytes (both B and T-cells).(Jason,2012) The information processing principles of the clonal selection theory describe a general learning strategy. This strategy involves a population of adaptive information units (each representing a problem-solution or component) subjected to a competitive processes for selection, which together with the resultant duplication and variation ultimately improves the adaptive fit of the information units to their environment.

### 3.3 Immunos

IMMUNOS1 algorithm is an artificial immune system based algorithm which assumes no data reduction, thus the clone population prepared is maintained and is used to classify unknown data instances. The artificial immune network algorithms includes the base version and the extension for optimization problems called the optimization artificial immune network algorithm (Jason, 2005). The Immunos-2 implementation is same as Immunos-1,the only difference is it seeks to provide some form of basic generalization via data reduction, and thus a closer representation to the original Immunos-81 proposal(Andrew and Jon, 2002 ).

### A. Data Set

Dataset was selected from the (UCI) machine learning repository(<https://archive.ics.uci.edu/>),specific to agricultural crops, the soybean [25] and mushroom [26] datasets. The soybean dataset contains 35 categorical features(See Table 5) and a class while the mushroom datasets contains 22 nominal features and a class(See Table 6). The mushroom data set includes descriptions of hypothetical samples corresponding to 23 species of gilled mushrooms in the agaricus and lepiota family. It has information for 8124 mushroom transactions in which 4208(51.8%) are edible and 3916(48.2%) are poisonous. In Soybean data set, the values for attributes are encoded numerically with the first value encoded as "0" and the second as "1".

### B. Data Preprocessing

Pre-processing is carried out in order to remove noise or useless data that will not contribute to the accuracy of the classifier. Irrelevant or redundant feature can result to high computational cost, high memory usage and reduced performance on the accuracy of the classifier.



### Normalization using the Min-Max Scaling

A suitable normalization technique is necessary to reduce the domination of features with higher values over features with lesser values so that the detection model would not be biased towards features having higher values ( You et al 2006). In this work, normalization is carried out to transform values of all features in to a common specific range by using the Min-Max scaling technique. The formulae for the normalization is giving below

$$z_i = \frac{x_i - \min(x)}{\max(x) - \min(x)}$$

### C. Feature Extraction Procedure

Principal Component Analysis (PCA) was used in this paper. PCA analyzes the relationships among multivariable, seeks the principal components denoted as a linear combination, and explains the entire changes with several components. The aim of PCA is to make the effective explanations through dimension reduction using linear equations (Geraldin & Bobby,2014). Although p components are required to reproduce the total system variability, often much of this variability can be accounted for by a small number, k, of the principal components. If so, there is almost as much information in the k components as there is in the original p variables. The k principal components can then replace the initial p variables, and the original data set, consisting of n measurements on p variables, is reduced to one consisting of n measurements on k principal components. The most common definition of PCA, is that, for a set of observed vectors  $\{v_i\}; i \in \{1, \dots, N\}$ , the q principal axes  $\{w_j\}; j \in \{1, \dots, q\}$  are those orthonormal axes onto which the retained variance under projection is maximal. It can be shown that the vectors  $w_j$  are given by the q dominant eigenvectors (i.e. those with largest associated eigenvalues) of the covariance matrix  $\Sigma$ .

## RESULTS AND DISCUSSION

This section presents the classification performance of AIRS1, ClonalG and Immnos1 on the dataset used. 10-fold cross validation is applied on both dataset. 10-fold cross validation process divides the dataset into 10 part, nine parts will be used as training data and one part is used as data for testing. The results were identified for the algorithms using, TP, FP, accuracy, precision and recall. Table 1 shows the TP, FP, Accuracy, precision and recall of the Soybean without the combination of PCA. Table 2 shows

Accuracy, Time taken, Precision, Recall, F-Measure and RMSE of the Soyabean dataset with the combination of PCA. Table 3 shows Accuracy, Time taken, Precision, Recall, F-Measure and RMSE of the Mushroom dataset with no combination of PCA. Table 4 shows Accuracy, Time taken, Precision, Recall, F-Measure and RMSE of the Mushroom dataset with the combination of PCA. The accuracy performance of AIRS1, Immunos1 and ClonalG has been compared to each other and this is shown in Figure 1.

AIRS1 performed best among all the other AIS algorithms in the two datasets. AIRS2 without PCA for the two dataset didn't a yield an optimal solution in a reasonable time . We compared our results with proven classifiers that have performed well on intrusion detection system. We choose ZeroR and J48 classifiers to compare with these AIS algorithms.

## CONCLUSION AND RECOMMENDATIONS

This paper provides a general baseline comparison for three popular AIS algorithms, namely AIRS1, ClonalG and Immunos1 and Immunos2 on crop dataset. Effectiveness of Mushroom edibility and Soybeans diseases detection using AIS algorithms was comparatively evaluated and the results were presented. Experimental results suggested that AIRS1 are effective and powerful for mushroom edibility and Soyabean disease detection achieved higher classification accuracies. Future work can include other AIS algorithms such as Dendritic cell algorithms (DCA) and Negative Selection Algorithms to test their performance in classifying crops for decision making.

Table 1: Soybeans without PCA

Attack Types	TP	FP	Accuracy	Time Taken	Precision	Recall	F-Measure	RMSE
<b>CSCA</b>	0.87	0.025	79.94	3.65	0.753	0.799	0.768	0.1455
<b>ClonalG</b>	0.552	0.049	55.19	0.43	0.547	0.552	0.528	0.201
<b>AIRS1</b>	0.813	0.021	81.25	1.23	0.756	0.813	0.778	0.141
<b>AIRS2</b>								
<b>Immunos1</b>	0.79	0.02	79.79	0	0.77	0.798	0.768	0.0213
<b>Immunos2</b>	0.32	0.105	31.77	0	0.32	0.32	0.187	0.268

Table 2: Soybeans with PCA

Attack Types	TP	FP	Accuracy	Time Taken	Precision	Recall	F-Measure	RMSE
<b>CSCA</b>	0.87	0.073	86.96	2.38	0.883	0.87	0.869	0.014
<b>ClonalG</b>	0.54	0.057	54.02	0.38	0.6	0.54	0.523	0.013
<b>AIRS1</b>	0.864	0.018	86.38	2.13	0.87	0.864	0.861	0.1197
<b>AIRS2</b>	0.837	0.02	83.74	0.5	0.842	0.861	0.836	0.02
<b>Immunos1</b>	0.861	0.01	86.09	0.06	0.902	0.483	0.867	0.143
<b>Immunos2</b>	0.483	0.08	48.31	0.03	0.394	0.816	0.365	0.2312

Table 3: Mushroom without PCA

Attack Types	TP	FP	Accuracy	Time Taken	Precision	Recall	F-Measure	RMSE
<b>CSCA</b>	0.846	0.162	84.61	494.64	0.861	0.846	0.844	0.3923
<b>ClonalG</b>	0.77	0.244	76.76	2.17	0.795	0.77	0.76	0.481
<b>AIRS1</b>	0.9	0.103	90	29.64	0.909	0.9	0.899	0.3161
<b>AIRS2</b>								
<b>Immunos1</b>	0.782	0.232	78.1	0.01	0.826	0.782	0.772	0.467
<b>Immunos2</b>	0.518	0.518	51.79	0.02	0.268	0.518	0.353	0.6943

Table 4: Mushroom with PCA

Attack Types	TP	FP	Accuracy	Time Taken	Precision	Recall	F-Measure	RMSE
<b>CSCA</b>	0.997	0.003	99.74	1795.03	0.997	0.997	0.997	0.0508

<b>ClonalG</b>	0.842	0.163	84.24	6.86	0.85	0.84	0.841	0.39
<b>AIRS1</b>	0.97	0.027	97.36	64.11	0.97	0.97	0.97	0.213
<b>AIRS2</b>	0.996	0.004	99.64	135.63	0.996	0.996	0.996	0.019
<b>Immunos1</b>	0.91	0.09	91.4	0.06	0.924	0.914	0.913	0.174
<b>Immunos2</b>	0.89	0.11	89.18	0.09	0.91	0.89	0.89	0.3289

Table 4 shows Accuracy, Time taken, Precision, Recall, F-Measure and RMSE of the Mushroom dataset with the combination of PCA.

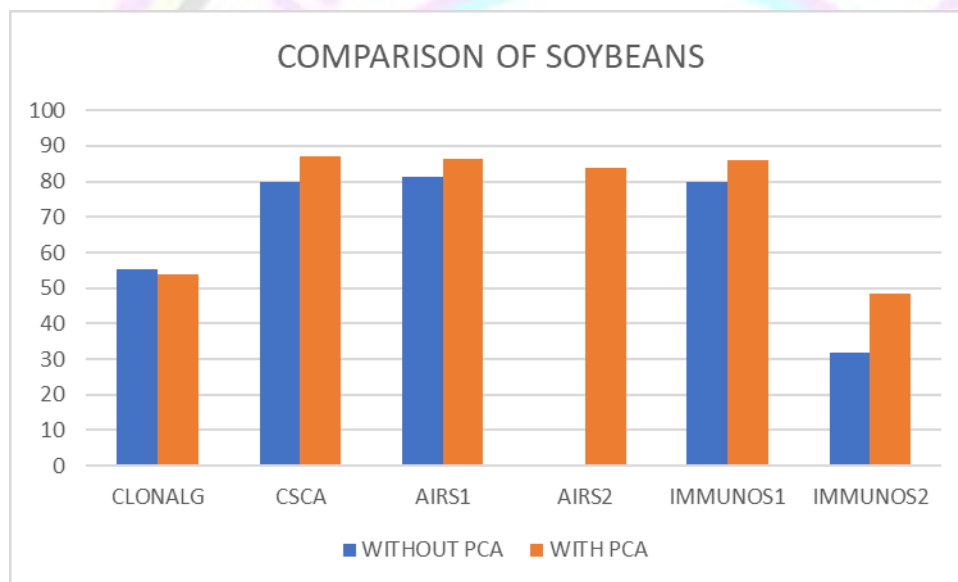


Fig. 1 Accuracy Classification for SoyBean with or without PCA

**Table 5 Mushroom Dataset**

Features and their Attributes
1. cap-shape: bell=b,conical=c,convex=x,flat=f, knobbed=k,sunken=s
2. cap-surface: fibrous=f,grooves=g,scaly=y,smooth=s
3. cap-color: brown=n,buff=b,cinnamon=c,gray=g,green=r, pink=p,purple=u,red=e,white=w,yellow=y
4. bruises?: bruises=t,no=f



5. odor: almond=a,anise=l,creosote=c,fishy=y,foul=f, musty=m,none=n,pungent=p,spicy=s
6. gill-attachment: attached=a,descending=d,free=f,notched=n
7. gill-spacing: close=c,crowded=w,distant=d
8. gill-size: broad=b,narrow=n
9. gill-color: black=k,brown=n,buff=b,chocolate=h,gray=g, green=r,orange=o,pink=p,purple=u,red=e, white=w,yellow=y
10. stalk-shape: enlarging=e,tapering=t
11. stalk-root: bulbous=b,club=c,cup=u,equal=e, rhizomorphs=z,rooted=r,missing=?
12. stalk-surface-above-ring: fibrous=f,scaly=y,silky=k,smooth=s
13. stalk-surface-below-ring: fibrous=f,scaly=y,silky=k,smooth=s
14. stalk-color-above-ring: brown=n,buff=b,cinnamon=c,gray=g,orange=o, pink=p,red=e,white=w,yellow=y
15. stalk-color-below-ring: brown=n,buff=b,cinnamon=c,gray=g,orange=o, pink=p,red=e,white=w,yellow=y
16. veil-type: partial=p,universal=u
17. veil-color: brown=n,orange=o,white=w,yellow=y
18. ring-number: none=n,one=o,two=t
19. ring-type: cobwebby=c,evanescent=e,flaring=f,large=l, none=n,pendant=p,sheathing=s,zone=z
20. spore-print-color: black=k,brown=n,buff=b,chocolate=h,green=r, orange=o,purple=u,white=w,yellow=y
21. population: abundant=a,clustered=c,numerous=n, scattered=s,several=v,solitary=y
22. habitat: grasses=g,leaves=l,meadows=m,paths=p, urban=u,waste=w,woods=d
<b>23. Class : edible or poisonous</b>

**Table 6 Soybean Data set**

Features and their Attributes	
1. date:	april,may,june,july,august,458ctober458r,458ctober,?.
2. plant-stand:	normal,lt-normal,?.
3. precip:	lt-norm,norm,gt-norm,?.
4. temp:	lt-norm,norm,gt-norm,?.

5. hail:	yes,no,?.
6. crop-hist:	diff-1st-year,same-1st-yr,same-1st-two-yrs, same-1st-sev-yrs,?.
7. area-damaged:	scattered,low-areas,upper-areas,whole-field,?.
8. severity:	minor,pot-severe,severe,?.
9. seed-tmt:	none,fungicide,other,?.
10. germination:	90-100%,80-89%,lt-80%,?.
11. plant-growth:	norm,abnorm,?.
12. leaves:	norm,abnorm.
13. leafspots-halo:	absent,yellow-halos,no-yellow-halos,?.
14. leafspots-marg:	w-s-marg,no-w-s-marg,dna,?.
15. leafspot-size:	lt-1/8,gt-1/8,dna,?.
16. leaf-shread:	absent,present,?.
17. leaf-malf:	absent,present,?.
18. leaf-mild:	absent,upper-surf,lower-surf,?.
19. stem:	norm,abnorm,?.
20. lodging:	yes,no,?.
21. stem-cankers:	absent,below-soil,above-soil,above-sec-nde,?.
22. canker-lesion:	dna,brown,dk-brown-blk,tan,?.
23. fruiting-bodies:	absent,present,?.
24. external decay:	absent,firm-and-dry,watery,?.
25. mycelium:	absent,present,?.
26. int-discolor:	none,brown,black,?.
27. sclerotia:	absent,present,?.
28. fruit-pods:	norm,diseased,few-present,dna,?.
29. fruit spots:	absent,colored,brown-w/blk-specks,distort,dna,?.
30. seed:	norm,abnorm,?.
31. mold-growth:	absent,present,?.
32. seed-discolor:	absent,present,?.

33. seed-size: norm,lt-norm,?.
34. shriveling: absent,present,?.
35. roots: norm,rotted,galls-cysts,?.
36. Class : diaporthe-stem-canker, charcoal-rot, rhizoctonia-root-rot, phytophthora-rot, brown-stem-rot, powdery-mildew, downy-mildew, brown-spot, bacterial-blight, bacterial-pustule, purple-seed-stain, anthracnose, phyllosticta-leaf-spot, alternarialeaf-spot, frog-eye-leaf-spot, diaporthe-pod-&-stem-blight, cyst-nematode, 2-4-d-injury, herbicide-injury.





## REFERENCES

- Andrew Watkins & Jon Timmis (2002). Artificial Immune Recognition System (AIRS): Revisions and Refinements
- R. Porkodi (2012). Comparison of Filter Based feature Selection algorithms : An overview
- Jason Brownlee. Clonal Selection theory and ClonalG: The Clonal Selection Classification Algorithm, Technical Report No, 2-02, January (2005)
- Jason Brownlee. 'Clever Algorithms Nature-Inspired Programming Recipes', Revision 2, 16 June 2012 ISBN: 978-1-4467-8506-5.
- Jason Brownlee(2005). 'Artificial Immune Recognition System (AIRS) A Review And Analysis', January 2005, Technical Report No. 1-02.
- Soybean (Large) Data Set. [Online]. Available: <https://archive.ics.uci.edu/ml/datasets/Soybean+%28Large%29>
- Mushroom Data Set. (Online). Available: <https://archive.ics.uci.edu/ml/datasets/Mushroom>
- Sanghmitra Dash, Rabindra Kishore Mishra, Rama Krusha Das and Manisha Panda (2016). Comparison of Classifier Outputs using AIS and Non-AIS Based Data Mining Algorithms
- Felix T.S Chan, Anuj Prakash, R.K Tibrewal and M.K. Tiwari (2013). Clonal Selection Approach for Network Intrusion Detection
- Subhadra Mishra, Debahuti Mishra and Gour Hari Santra(2016). Applications of Machine Learning Techniques in Agricultural Crop Production : A Review Paper
- Ayodele Lasisi, Rozaida Ghazali, Tutut Herawan, Fola Lasisi, Mustafa Mat Deris(2015). Knowledge Extraction of Agricultural Data using Artificial Immune System
- Jihen Amara, Bassem Bouaziz, Alsayed Algergawy(2017). A deep learning-based Approach for Banana Leaf Diseases Classification
- Agung Wibowo, Yuri Rahayu, Andi Riyanto, Taufik Hidayatulloh(2018). Classification Algorithm for Edible Mushroom identification
- S.Hari Ganesh, Pritty Cindrella, Joy Christy(2015). A review on Classification Techniques over Agricultural Data
- Geraldin B. Cruz, Bobby D. Gerardo and Bartolome T. Tanguilig(2014). Agricultural Crops Classification Models Based on PCA-GA Implementation in Data Mining
- Surabhi Chouhan, Divakar Singh, Anju Singh(2016). A Survey and Analysis of Various Agricultural Classification Techniques
- Geraldin B. Cruz(2015). Comparative Study of Data Mining Classification Techniques over Soybean Disease by Implementing PCA-GA

# INTERNET OF THINGS (IOT): EMERGING TOOL FOR FOOD SECURITY IN AGRICULTURE

Bamigboye<sup>1\*</sup>, F. O., E. O. Ademola<sup>2</sup>

<sup>1</sup> Afe Babalola University, Ado-Ekiti, Nigeria.

<sup>2</sup> Trademark Owner of Power-Age (Management Consulting) Chairman, P-ACC 2 Edenbridge Close Orpington, Kent BR5 3SL United Kingdom

\*Corresponding Author's E-mail: [bamigbovefo@abuad.edu.ng](mailto:bamigbovefo@abuad.edu.ng), GSM: [07066622836](tel:07066622836)

## ABSTRACT

The present paper discussed the use of Internet of Things (IoT) as technological tools in solving inherent agricultural challenges to forestall food insecurity. The use of IoT in crop production as par weather forecast, soil monitoring, pest, insects and diseases monitoring and irrigation was considered. While in animal production: animal health monitoring, animal nutrition, reproductive parameters and performance monitoring were considered. Future opportunities that researchers can key into were highlighted. In conclusion, IoT is a technological tool for securing food in Africa.

**KEYWORDS:** Internet of Things, sensors, monitoring devices, animal productivity and crop production

## INTRODUCTION

Food insecurity is becoming a serious threat to life in many parts of Africa in the recent times. Insufficient production and disease outbreaks on crops and animals can lead to food insecurity, economic downturn and death due to hunger, reduced quality and halting access to important export markets. Importation of crops and animal products to subsidize indigenous production is on the increase and this is not sustainable; it is cost-ineffective. However, these challenges can be combated through production of crops and animals in commercial quantity.

Profitable production of crops and animals in large quantity is hinged on improved practices, use of modern equipment and in the recent times, IoT. Internet of Things (IoT) is the network of physical objects, devices, vehicles, buildings and other items which are embedded with electronics, software, sensors and network connectivity which enables these objects to collect and exchange data (GSI, 2015). The Internet of Things allows objects to be sensed and controlled remotely across existing network infrastructure, creating opportunities for more-direct integration between the physical world and computer-based systems, and resulting in improved efficiency, accuracy and economic benefit. IoT is any object which is capable of identifying, connecting and communicating with other objects (Santucci, 2011; LOPEZ Research Series, 2013; Reddy, 2014).

Weather forecast can be synonymous to good cropping; it accords the farmer pre-knowledge of

weather situation hence, cropping activities are tailored to achieving successful and bountiful crop production. Disease surveillance empowers the farmers with ability to nib the problem at the bud before getting out of hands. Precision in the use of water, fertilizers and drug/chemicals prevents wastefulness, high cost of production, environmental hazards and pollution and health implications on consumers. Efficient management of these resources leads to better production gains. Animal health and tracking can be monitored and documented for later use. Animal feeding and nutrition are critical to the profitability of any farm. Compounding a balanced ration for the different categories and classes of farm animals and feeding them required quantity can reduce cost of production. Ovulation and parturition in animals are tantamount to reproduction. Any mishap at these periods lowers animal production. Internet of things has emerged as a viable tool that can address these critical issues in agricultural production.

## INTERNET OF THINGS AS TOOL FOR COMBATING FOOD INSECURITY IN CROP PRODUCTION

### *Weather forecast and soil monitoring*

Weather is a paramount factor to be considered in crop and animal agriculture. Hence, weather forecasting and monitoring must be accurately predicted so as to carry out production activities to time for eventual improved productivity (Bamigboye

and Ademola, 2016). In Africa, most farmers still rely on the traditional methods and practices to produce crops and animals. The most important barrier that arises in traditional farming is climatic change. The number of effects of climatic change includes heavy rainfall, most intense storm and heat waves, less rainfall etc. Due to these the productivity decreases to a large extent. Climatic change also raises the environmental consequences such as seasonal changes in life cycle of plants. To boost the productivity and minimize the barriers in agriculture field, there is need to use innovative technology and techniques called Internet of Things (Malavade and Alukwar, 2016).

Weather forecasting can be done through analysis of weather data over long periods to reduce agricultural risk. This is referred to as big data analysis. In weather forecasts for pest management, humidity, precipitation, crop type, soil fertility, leaf wetness, temperature, winds and soil moisture are collected at local level through sensors. The life cycle of pests is monitored along with the climate data, allowing researchers to predict pest outbreaks more accurately because pest maturation depends on environmental conditions (Dlodlo and Kalezhi, 2015). Internet of Things provides basis for irrigation schedule depending on temperature and soil moisture; it can also provide the dose of irrigation.

Temperature, humidity, light intensity, and soil moisture can be monitored through various sensors. These can then be linked to systems to trigger alerts or automate processes such as water and air control. IoT sensors are capable of providing farmers with information about crop yields, rainfall, pest infestation, and soil nutrition are invaluable to production and offer precise data which can be used to improve farming techniques over time (Huang, 2014). Soil management such as pH level, moisture content and condition can be identified easily (sensors) so that farmer can sow seeds according to soil level (Malavade and Akulwar, 2016) for optimum crop production. Vijaykumar (2011) and Zhang *et al.*, (2010) studied the work of rural farming community that replaces some of the traditional techniques. The sensor nodes have several external sensors namely leaf wetness, soil moisture sensor, soil pH, atmospheric pressure sensors attached to it. Based on the soil moisture sensor the node triggers the water sprinkling during the period of water scarcity and switches off after adequate water is sprinkled. This results in water conservation and soil pH is sent to the base station and in turn base station intimates the farmer about soil pH via SMS using

GSM model. This information helps the farmers to reduce quantity of fertilizers used.

### ***Pest, insects and diseases monitoring and irrigation in crop production using IoT***

Agriculture is one of the major industries to incorporate drones. Drones are being used in agriculture to enhance various agricultural practices. The ways ground-based and aerial based drones are used to assess crop health, carry out irrigation, crop monitoring, crop spraying, planting, and soil and field analysis. The major benefits of using drones include crop health imaging, integrated GIS mapping, ease of use, saves time, and the potential to increase yields. With strategy and planning based on real-time data collection and processing, the drone technology can give a high-tech makeover to the agriculture industry (Ravindra, 2018).

Drones can gather valuable data via a series of sensors that are used for imaging, mapping, and surveying of agricultural land. These drones perform in-flight monitoring and observations. From the drone data, insights can be drawn regarding plant health indices, plant counting and yield prediction, plant height measurement, canopy cover mapping, scouting reports, stockpile measuring, chlorophyll measurement, nitrogen content, drainage mapping and weed pressure mapping (Ravindra, 2018).

The use of drip irrigation system for wetting plants eliminates waste of water and fertilizers. Sensors are used to detect the moisture and nutrient deficiencies of plant and soil while the right quantity is allowed to drop where it is needed. As such, under or over watering is eliminated. This can be said to be precision agriculture and it can lead to great harvest even in dry/drought periods of the year. Crops that are naturally unavailable in dry season can be readily made abundant through this means (Bamigboye and Ademola, 2016). Also, sensors can be set up to look for early signs of pests or disease (Huang, 2014).

Sensors and RFID chips aids to recognize the diseases occurred in plants and crops. RFID tags send the EPC (information) to the reader and are shared across the internet. The farmer or scientist can access this information from a remote place and take necessary actions; automatically crops can be protected from coming diseases (Deeksha Jain *et al.*, 2012).

## **INTERNET OF THINGS AS TOOL FOR COMBATING FOOD INSECURITY IN ANIMAL PRODUCTION**

### ***Livestock Management***



Traditional animal production techniques are usually labour intensive and driven by very slim margins. These margins are subject to variables such as meat and milk prices, growth rates of animals, governmental policy changes and volatile risk of infectious disease resulting in livestock losses, increased veterinary inputs and reduced meat prices. However, the world population is rapidly increasing; world meat production is predicted to double by 2050 (FAO, 2009). Hence, farming techniques are changing from traditional towards intensification.

Livestock management has to do with feeding, health care and breeding of animals. Good management system enhances productivity. The cost of raising livestock continues to rise every year. At the same time, the public is also pushing for the more humane treatment of animals as animals reared in a humanely produce higher quality meat that is more nutritious. Under pressure to reduce costs and raise their livestock in a more humane manner, farmers are starting to turn to Internet of Things (IoT) technology. For humane slaughtering, sensors connected to internet can be embedded on the livestock and they do not suffer discomfort while they are slaughtered. Using information from these sensors, farmers are able to monitor the overall health of the animal by analyzing blood pressure, heart rate, and other parameters. If any of these parameters veer outside the accepted ranges, farmers would have the knowledge that “all is not well” with the animal and necessary treatment can be administered. Not only can these sensors help monitor the health of the animal, GPS technology can also help track the animal’s location. Location monitoring can be extremely useful to farmers rearing free range or pastured livestock as it would enable farmers to better account for their livestock (QLIKTAG, 2017).

Animal monitoring device was developed and used to detect animal physiological parameters such as body temperature; physical gestures like sitting, standing, eating and heartbeat, environmental parameters such as air temperature and relative humidity. The device is mounted on the neck (collar), senses the values and predicts the health status of the animal by using cloud IoT analytics platform. The result is made available to the farmer on his mobile phone that has been installed with the app. The accuracy of the system is 90 per cent (Saravanan and Saraniya, 2018).

In Nigeria, feed dispensing methods working based on IoT were developed by researchers. In Arulogun *et al.* (2010) a mobile intelligent poultry feed dispensing system was developed. The system was

able to move, detect and avoid obstructions and dispense solid feed to poultry birds. However, Olaniyi *et al.* (2014) designed a mobile intelligent poultry feed and water dispensing system; using fuzzy logic control technique.

Breeding in animal guarantees continuity. Heat detection determines the success of breeding – it can occur unnoticed by the herder. A device, equipped the herd with battery powered pedometers was developed to detect the number of steps, wirelessly transmitted the information to an MS Azure DB where it was analyzed and notified the farmer via mobile phone app when the time was right for insemination. With a smartphone, the farmer can scan barcoded cow while milk is being collected and log that data against the digital record for the cow on the internet. This would not just create an individual log for every cow but also help analyse patterns and optimize productivity. Farmers can use IoT solutions to monitor livestock reproductive cycles and the calving process to promote safer and more successful outcomes. Biosensors allow farmers to optimize yield in this short period through a predictive approach. These gadgets are also designed to survive even the toughest environments in the farm while constantly measuring data. This data is being analyzed on the cloud in terms of the number of steps the cows takes during the day (QLIKTAG, 2017). Wireless sensor can detect when a cow is going into active labor. It is strapped to the tail, where it can monitor movement for the patterns of activity that mean a calf is on the way. Then Moocall uses the 3G mobile network to send a text alert to the farmer, who should have about an hour to prepare for the arrival of the newborn (Postscape, 2016).

Automatic milking systems are IoT controlled systems that milk the dairy cattle without human labor. The complete automation of the milking process is controlled by an agricultural robot, complex herd management software, and specialized computers. Automatic milking eliminates the farmer from the actual milking process, allowing for more time for supervision of the farm and the herd. Farmers can also improve herd management by using the data gathered by the computer. By analyzing the effect of various animal feeds on milk yield, farmers may adjust accordingly to obtain optimal milk yields. Since the data is available down to individual level, each cow may be tracked and examined, and the farmer may be alerted when there are unusual changes that could mean sickness or injuries (Chauhan, 2018)

## **OTHER USES OF IOT IN AGRICULTURE TO COMBAT FOOD INSECURITY**

Deter theft – Farm security cameras in areas such as holding pens, calving pens, tool shops, and gates will help to prevent thieves from stealing animals and equipment (Chauhan, 2018).

Monitor daily operations – Security cameras can also ensure that daily operations such as milking and feeding run smoothly (Chauhan, 2018).

Employee monitoring – Video surveillance can be used to monitor employee behavior so that critical farm operations are properly carried out (Chauhan, 2018).

Remote playback and monitoring – With an IP-based surveillance system, farm owners can monitor their property remotely (Chauhan, 2018)

Purchases: As farmers use technology to make better-informed purchasing decisions, the internet and proliferation of data can quickly uncover where to find the best prices for any product or service.

## **FUTURE RESEARCH OUTLETS IN IOT THAT CAN COMBAT FOOD INSECURITY**

- Feed formulation determines the inherent mix of nutrients that make-up a feed. For all classes of animal at different stages in life and at various physiological periods require different nutrients for optimum performance, hence, the importance of feed formulation. Over-feeding reduces farmer's profit and increases environmental pollution while under-feeding reduces performance. An IoT device that can formulate feeds for any class of animal based on information supplied on available feedstuffs and animal requirement, dispense to the animal the required quantity using information on its body weight can increase animal productivity.
- Many devices used in IoT are connected to android phone where the apps are installed. The app to be installed on farmers' mobile phone should be written in their local languages for good understanding and better performance.

- Government should make internet available and accessible to the remotest parts where farmers are found.
- In Nigeria, most of the farm produces are not always available in industrial quantity in a place at a given time. Hence, buyers or middlemen go around seeing farmers that are ready to sell their produces at a given time and they buy from them in bits. Transporting these goods is also a big challenge in Nigeria, due to the fact that they are purchased in bits, the produce sometimes may not fill up a lorry. However, with the advent of IoT, the transporter can be guided to others in the vicinity in need of this service (Bamigboye and Ademola, 2016).

## **CONCLUSION AND RECOMMENDATIONS**

Internet of Things increases productivity, reduce manual work and time dedicated to work, and increase efficiency. Hence, IoT can be said to be the technological tool for alleviating food insecurity in Africa. Also, if well and widely adopted in Africa, it will make farming more attractive and lucrative to the youths. Government and network should make internet available to farmers at affordable price.



## REFERENCES

- Arulogun, O. T., Olaniyi O.M., Oke, O.A., and D.O. Fenwa (2010). Development of mobile Intelligent Poultry Feed and Water Dispensing System. *Medwell journals of Engineering and Applied Science*, 5(3), 229- 233.
- Bamigboye, F.O., and O. Ademola (2016). Internet of Things (Iot): It's Application For Sustainable Agricultural Productivity in Nigeria. 6<sup>th</sup> Proceedings of the iSTEAMS Multidisciplinary Cross-Border Conference, held at University of Professional Studies, Accra Ghana, 2016. Pp. 309-312.
- Chauhan R. M. (2018). Advantages and Challenges in E Agriculture. *Oriental Journal of Computer Science and Technology* 8(3). Available from: <http://www.computerscijournal.org/?p=296>
- Deeksha Jain, P. Venkata Krishna and V. Saritha. (2012). "A Study on Internet of Things based Applications", [Online]. Available: <https://arxiv.org/abs/1206.389>
- Dlodlo, N. and J. Kalezhi, (2015). The Internet of things in Agriculture for sustainable rural development. International conference on Emergence Trends Networks and Computer Communications at Windhoek, Namibia.
- F.A.O. (Food and Agriculture Organisation) (2009). How to feed the World in 2050. [http://www.fao.org/fileadmin/templates/wsfs/docs/expert\\_paper/How to Feed the World in 2050.pdf](http://www.fao.org/fileadmin/templates/wsfs/docs/expert_paper/How_to_Feed_the_World_in_2050.pdf)
- GSI (Global Standard Initiatives) (2015). Internet of Things Global Standards Initiative. Available at <http://www.itu.int/en/ITU-T/gsi/iot/Pages/default.aspx>
- Huang, R. (2014): Internet of Things: 5 applications in Agriculture. Available at <http://blog.hwtrek.com/p=626>
- LOPEZ Research Series, (2013). An introduction to the Internet of things (IoT), part 1. Available at [http://www.cisco.com/c/dam/en\\_us/solutions/trends/iot/introduction to IoT november.pdf](http://www.cisco.com/c/dam/en_us/solutions/trends/iot/introduction_to_IoT_november.pdf)
- Malavade, V. N. and P.K. Akulwar (2016): Role of IoT in Agriculture. *IOSR Journal of Computer Engineering (IOSR-JCE)* e-ISSN: 2278-0661,p-ISSN: 2278-8727 PP 56-57
- Postscape, (2016). IoT Smart Farming. Available at: <https://www.postscapes.com/smart-agriculture/>
- Ravindra, S. (2018). IoT Application in Agriculture. Available at <https://www.iotforall.com/iotapplicationinagriculture.org>
- Reddy, A. S (2014). Reaping the Benefits of the internet of things. Cognizant report. Available at <http://www.cognizant.com/InsightsWhitepapers/Reaping-the-Benefits-of-the-Internet-of-Things.pdf>
- Santucci, G. (2011). The Internet of Things: Between the Revolution of the Internet and the Metamorphosis of Objects <http://cordis.europa.eu/fp7/ict/enet/documents/publications/iot-between-the-internet-revolution.pdf>
- Saravanan K., and S. Saraniya (2018). "Cloud IOT based novel livestock monitoring and identification system using UID", *Sensor Review*, Vol. 38 Issue: 1, pp.21-33, <https://doi.org/10.1108/SR-08-2017-0152>
- QLIKTAG (2017). Putting Cows on the Internet of Things. Available at <https://www.qliktag.com/putting-cows-on-the-internet-of-things/>
- Vijayakumar, S. and J. Nelson Rosario (2011). "Preliminary Design for Crop Monitoring Involving Water and Fertilizer Conservation Using Wireless Sensor Networks", *Communication Software and Networks (ICCSN)*, 2011 IEEE 3rd International Conference.
- Wang, X and N. Liu (2014). "The application of internet of things in agricultural means of production supply Chain management" *Journal of Chemical and Pharmaceutical Research* 6(7):2304-2310, ISSN: 0975-7384.
- Zhang, L., M. Yuan, D. Tai, X. Oweixu, X. Zhan and Y. Zhang (2010). "Design and implementation of granary monitoring system based on wireless sensor network node" International Conference on Measuring Technology and Mechatronics Automation.



# CHEMICAL COMPOSITION, PHYSICAL AND SENSORY PROPERTIES OF CAKES PREPARED FROM FLOUR BLENDS OF WHEAT AND CASHEW NUT KERNELS.

Yakubu, C. M.\*, James, S., Maxwell, Y. M. O., Joseph F., Ocheme, O. B. and Zubair B. A.

## ABSTRACT

The chemical composition, physical and sensory properties of cakes prepared from flour blends of wheat and cashew nut kernels were investigated. Wheat and cashew nut kernels flour were blended at different proportions (100:0%; 90:10%; 80:20%; 70:30%; 60:40% and 50:50%) for cake making where 100% wheat flour was used as standard. Addition of cashew nut kernels flour to wheat flour increased chemical composition of cake samples such as moisture, protein, fat, crude fiber, ash contents from (13.19 to 14.42%), (23.05 to 29.36%), (3.41 to 7.06%), (3.57 to 3.95%), (1.42 to 4.02%), while carbohydrate content decreased from (54.28 to 41.19Kcal), similar trend was observed for wheat flour. Mineral elements of cakes such as copper, iron, magnesium, sodium, calcium and phosphorus ranged from 0.13 to 0.19mg/100g, 2.95 to 4.43mg/100g, 61.65 to 164.64mg/100g, and 273.52 to 264.24mg/100g, 56.33 to 123.27.05 mg/100 g and 298.70 to 356.03 mg/100g respectively. The weight (32.25 to 34.30 g) and volume (242.05 to 246.11 cm<sup>3</sup>) of wheat-cashew nut kernels flour cake increased, whereas batter density and volume index of cakes decreased from (0.90 to 0.83) and (103.65 to 99.47) with increasing levels of cashew nut kernels flour. There was no significant ( $p \geq 0.05$ ) difference in crust and crumb colour, crumb grain and texture between wheat cake and composite cakes but taste and overall acceptability of composite cakes were significantly different from the standard.

**Keywords:** wheat, cashew nut kernels, cake, flour blends,

## Introduction

Cakes are soft bakery products produced by baking batter containing wheat flour, sugar, baking powders and beaten eggs, with or without shortenings (IFIS, 2005). Cake serves as a medium for delivery of important nutrients and the nutritional content varies with the type of flour used. There is an increase in demand of baked products such as cakes, bread and cookies resulting to high demand for imported wheat flour in Nigeria.

Department of Food Science and Technology,  
Federal University of Technology, Minna, Niger  
State, Nigeria.

author: [calebs@futminna.edu.ng](mailto:calebs@futminna.edu.ng)

\*Corresponding

The current global economic meltdown has

partly resulted in an upsurge in the number

of well-informed consumers who put into

consideration the health and nutritional

benefits of food products they consume; and

this has contributed to the stimulation of

research into alternative food crops with

functional or health benefits to

Amino acids, which include lysine, tryptophan, isoleucine and leucine and it has a high biological value (Bicalho and Schuch, 2001). The full fat cashew nut kernels contain protein 20.23%, ash 6.26%, fat 45.17% ,crude fiber 4.55%, carbohydrate 11.39%, energy value 533.01 kcal, iron 3.00 g, calcium 321.66 g, phosphorus 450.13 g, sodium 101.24 g, potassium 503.16 g.(Aloboet *al.*,2009). Considering these impressive chemical and functional properties of cashew nut kernels and its full fat flour it may represent a useful material in food systems. The present research therefore aimed at evaluating the effect of cashew nut kernels flour addition on the chemical composition, physical and sensory properties of wheat flour and cakes prepared from their flour bends.

### **Materials and Methods**

Three kilograms of wheat flour (Golden Penny), cashew nut seeds and other ingredients were all purchased from Minna Central Market, Nigeria while the Department of Food Science and Technology, Federal University of Technology, Minna provided the facilities for the work.

### **Preparations of cashew nut kernels flour**

Cashew nut kernels flour was prepared as described by Aloboet *al.* (2009). The nuts were split open with knife to release the kernels. The kernels were dried at 60°C in an air-draft oven (Gallenkamp 300 plus series, England) and then ground into flour using attrition mill (Globe P

44, China). The flour samples were passed through 75µm mesh size sieve, packaged in an air tight polyethylene bag and transferred into a plastic container with lid then stored in a refrigerator from where samples were taken for analysis.

### **Formulation of blends**

Wheat flour and cashew nut kernels flour was mixed at varied proportions (100: 0%; 90 : 10 %;

80 : 20%; 70 : 30 %; 60 : 40% and 50 : 50% ) where 100% wheat flour served as standard. A

Kenwood mixer was used for mixing samples at speed 6 for 5 minutes to achieve uniform mixing.

### **Proportion of ingredients**

The proportion of ingredients used consists of flour (100 g), sugar (62.5 g), margarine (47.9 g), baking powder (5.7 g) and vanilla essence (three drops) as described by Akubor (2004).

### **Preparation of cake**

The method of Akubor (2004) was adopted for the preparation of cake. The margarine and sugar were creamed manually for 2 min in a bowl until soft and fluffy. The egg was beaten for 3 min, added to the mixture and mixed manually for 3 min. Flour samples from various composite blends were separately sieved, and baking powder was then added and mixed lightly by hand until soft dough was formed. The dough was transferred to a greased baking pan and baked in a

preheated oven at 200 °C for 30 min.

3





### **Chemical analysis**

The moisture content, crude protein, fat content, crude fiber, ash content, carbohydrate and mineral determination were determined following the procedure outlined by AOAC (2000). The food energy values of the samples were determined according to the method described by Osborne and Voogt (1978).

### **Determination of physical properties of cake**

Batter density was determined with a measuring cylinder and expressed as the relation between the weight of batter and the same volume of distilled water. Volume index of cake samples were measured using AACC template method 1091 (AACC, 2000) while the weight of cake samples were determined by weight measurement using the electronic digital balance.

### **Determination of sensory properties**

A trained twenty-member panel consisting of students and staff members of Food Science and Technology Department of Federal University of Technology, Minna, Nigeria was selected based on their experience and familiarity with cake for the sensory evaluation. Cake samples prepared from each flour blend were presented in coded white plastic plates. The order of presentation of samples to the panel was randomized. Tap water was provided to rinse the mouth between evaluations. The panelists were instructed to evaluate the coded samples for appearance, crust colour, crumb grain, texture, aroma and overall acceptability. Each sensory attribute was rated on a 9-point Hedonic scale (1=disliked extremely while 9=liked extremely).

### **Statistical Analysis**

Data were analyzed by analysis of variance (Steel and Torrie, 1980). The difference between mean values was determined by least significant difference (LSD) test. Significance was accepted at 5% probability level.

### **Results and Discussion**

Tables 1 and 2 showed the chemical composition of flour blends from wheat and cashew nut kernels. There was no significant difference ( $p \geq 0.05$ ) in moisture value among samples. The low moisture values (9.13 to 10.56%) obtained in this study is indicative that the flour samples will have good storage life. The protein content varied between 10.61 and 25.72% with 100% wheat flour having lowest protein content, while 100% cashew nut kernels flour had the highest protein value. The protein content of flour blends increased with increasing level of cashew nut kernels flour in the blends. There were significant differences ( $p \leq 0.05$ ) in protein content among flour blends implying that the treatment had effect.

**Table1: Proximate composition of flour blends from wheat and cashew nut kernels.**

Flour blends	Moisture (%)	Protein (%)	Fat (%)	Crude fiber (%)	Ash (%)	Carbohydrate (%)
Wheat:						
Cashew nut						
100:0 (control)	9.13 <sup>b</sup> ±0.05	10.61 <sup>g</sup> ±0.18	1.25 <sup>g</sup> ±0.12	0.88 <sup>e</sup> ±0.01	1.25 <sup>c</sup> ±0.04	76.88 <sup>a</sup> ±0.60
0:100	10.56 <sup>a</sup> ±0.13	25.72 <sup>a</sup> ±0.24	12.18 <sup>a</sup> ±0.25	5.27 <sup>a</sup> ±0.06	7.64 <sup>a</sup> ±0.00	38.63 <sup>g</sup> ±0.47
90:10	9.25 <sup>b</sup> ±0.07	12.03 <sup>f</sup> ±0.16	3.04 <sup>f</sup> ±0.07	1.68 <sup>d</sup> ±0.01	1.89 <sup>b</sup> ±0.03	72.11 <sup>b</sup> ±0.56
80:20	9.33 <sup>b</sup> ±0.20	13.74 <sup>e</sup> ±0.05	4.11 <sup>e</sup> ±0.10	2.14 <sup>c</sup> ±0.04	2.06 <sup>b</sup> ±0.09	68.62 <sup>c</sup> ±0.72
70:30	9.51 <sup>b</sup> ±0.11	14.89 <sup>d</sup> ±0.17	5.52 <sup>d</sup> ±0.12	2.75 <sup>bc</sup> ±0.01	2.87 <sup>ab</sup> ±0.00	64.46 <sup>d</sup> ±0.39
60:40	9.68 <sup>b</sup> ±0.07	16.30 <sup>c</sup> ±0.33	6.75 <sup>c</sup> ±0.00	3.02 <sup>b</sup> ±0.07	3.15 <sup>b</sup> ±0.02	61.10 <sup>e</sup> ±0.56
50:50	9.75 <sup>b</sup> ±0.19	17.23 <sup>b</sup> ±0.08	7.90 <sup>b</sup> ±0.01	3.65 <sup>b</sup> ±0.15	3.49 <sup>b</sup> ±0.01	57.98 <sup>f</sup> ±0.97

Values followed by different superscript in a column are significantly ( $p \leq 0.05$ ) from each other

The high protein, fat, ash, crude fiber and mineral contents of cashew nut kernels flour was

expected since cashew nut kernels contains higher protein, fat and ash contents than wheat. The

chemical composition of wheat flour and

cashew nut kernels flours obtained in this study is in

close agreement with values reported by Ayo *et al.* (2007) and Alozie *et al.* (2009) for cashew nut

kernels flour and wheat flours respectively.

**Table 2: Mineral contents of flour blends from wheat and cashew nut kernels**

Blends	Copper (mg/100g)	Iron (mg/100g)	Magnesium (mg/100g)	Sodium (mg/100g)	Calcium (mg/100g)	Phosphorus (mg/100g)
Wheat:						
Cashew nut						
100:0 (control)	0.09 <sup>a</sup> ±0.01	2.74 <sup>b</sup> ±0.00	60.65 <sup>g</sup> ±0.16	268.91 <sup>a</sup> ±1.14	54.45 <sup>g</sup> ±0.33	270.03 <sup>g</sup> ±1.78
00:100	0.11 <sup>a</sup> ±0.00	3.03 <sup>b</sup> ±0.01	87.37 <sup>f</sup> ±0.11	99.83 <sup>b</sup> ±0.72	319.05 <sup>a</sup> ±0.89	466.13 <sup>a</sup> ±1.23
90:10	0.13 <sup>a</sup> ±0.01	3.10 <sup>ab</sup> ±0.00	88.97 <sup>e</sup> ±0.24	268.90 <sup>a</sup> ±1.35	70.82 <sup>f</sup> ±0.65	313.45 <sup>f</sup> ±0.98
80:20	0.14 <sup>a</sup> ±0.00	3.45 <sup>ab</sup> ±0.03	113.70 <sup>d</sup> ±0.90	268.13 <sup>a</sup> ±1.10	84.40 <sup>e</sup> ±0.30	319.05 <sup>e</sup> ±1.30
70:30	0.14 <sup>a</sup> ±0.00	3.70 <sup>a</sup> ±0.01	122.05 <sup>c</sup> ±0.83	266.08 <sup>b</sup> ±1.23	103.21 <sup>d</sup> ±0.82	328.10 <sup>d</sup> ±1.21
60:40	0.15 <sup>a</sup> ±0.02	4.04 <sup>a</sup> ±0.02	136.69 <sup>b</sup> ±0.69	264.24 <sup>c</sup> ±0.94	111.72 <sup>c</sup> ±0.64	348.75 <sup>c</sup> ±0.97
50:50	0.15 <sup>a</sup> ±0.00	4.19 <sup>a</sup> ±0.05	162.46 <sup>a</sup> ±0.95	263.77 <sup>c</sup> ±1.01	122.04 <sup>b</sup> ±0.97	357.90 <sup>b</sup> ±1.56

Values followed by different superscript in a column are significantly ( $p \leq 0.05$ ) different from each other.

The chemical composition of cakes prepared from flour blends of wheat-cashew nut kernels are

presented in Tables 3 and 4. Addition of cashew nut kernels flour to wheat flour increased

proximate composition of cake samples

such as moisture, protein, fat, crude fiber and ash

contents while carbohydrate content decreased from (54.28 to 41.19 Kcal). A similar trend was

also observed for mineral elements such as copper, iron, magnesium,

**Table 3: Proximate composition of cakes prepared from flour blends of wheat and cashew nut kernels**

Flour blends Wheat: Cashew nut	Moisture (%)	Protein (%)	Fat (%)	Crude fiber (%)	Ash (%)	Carbohydrate (%)
100:0 (control)	14.27 <sup>a</sup> ±0.34	23.05 <sup>f</sup> ±0.61	3.41 <sup>f</sup> ±0.12	3.57 <sup>d</sup> ±0.04	1.42 <sup>d</sup> ±0.00	54.28 <sup>a</sup> ±1.03
90:10	13.19 <sup>c</sup> ±0.51	24.12 <sup>e</sup> ±0.49	3.78 <sup>e</sup> ±0.09	3.63 <sup>d</sup> ±0.01	1.95 <sup>cd</sup> ±0.03	53.33 <sup>b</sup> ±0.97
80:20	13.56 <sup>c</sup> ±0.29	25.39 <sup>d</sup> ±0.37	4.96 <sup>d</sup> ±0.11	3.71 <sup>c</sup> ±0.07	2.66 <sup>c</sup> ±0.01	49.72 <sup>c</sup> ±1.34
70:30	13.89 <sup>bc</sup> ±0.55	26.14 <sup>c</sup> ±0.68	6.03 <sup>c</sup> ±0.06	3.84 <sup>bc</sup> ±0.00	2.78 <sup>c</sup> ±0.05	47.32 <sup>d</sup> ±0.86
60:40	13.96 <sup>b</sup> ±0.27	28.10 <sup>b</sup> ±0.49	6.83 <sup>b</sup> ±0.02	3.88 <sup>a</sup> ±0.03	3.81 <sup>b</sup> ±0.01	44.12 <sup>e</sup> ±0.95
50:50	14.42 <sup>b</sup> ±0.16	29.36 <sup>a</sup> ±0.23	7.06 <sup>a</sup> ±0.14	3.95 <sup>b</sup> ±0.01	4.02 <sup>a</sup> ±0.03	41.19 <sup>f</sup> ±1.08

Values followed by different superscript in a column are significantly ( $p \leq 0.05$ ) from each other

sodium, calcium and phosphorus. The higher moisture content of composite cakes than 100% wheat cake may be attributed to high water-binding properties of the cashew-wheat flour blends than wheat flour.



The increased protein, fat, crude fiber, ash, energy value and mineral contents of cake samples prepared from composite blends may be because of the addition effect of cashew nut kernels flour since cashew nut kernels flour contain higher protein, ash, fat, crude fiber and mineral contents than wheat flour. However, the higher protein, ash, crude fiber and low carbohydrate contents of composite cakes than control implies that the composite cakes are of nutritional value than 100% wheat cake. While, low

carbohydrate content of composite cakes is an indication that the cookies may serve as a functional food for groups with special caloric and glycemic requirements such as obese or diabetic people. The proximate composition of composite cakes and 100% wheat cakes obtained in this study was higher than to those of Alozie *et al.* (2009) and Akubor (2004) for wheat- African yam and wheat-cowpea cakes respectively, but in close agreements with the values reported by Chinma *et al.* (2010) for wheat-tiger nut cake.

**Table 4: Mineral contents of cakes prepared from flour blends of wheat and cashew nut kernels**

Blends	Copper (mg/100g)	Iron (mg/100g)	Magnesium (mg/100g)	Sodium (mg/100g)	Calcium (mg/100g)	Phosphorus (mg/100g)
Wheat: Cashew nut						
100:0 (control)	0.13 <sup>b</sup> ±0.17	2.95 <sup>c</sup> ±0.01	61.14 <sup>f</sup> ±0.18	273.52 <sup>a</sup> ±0.95	56.33 <sup>f</sup> ±0.29	298.70 <sup>f</sup> ±0.80
90:10	0.14 <sup>a</sup> ±0.30	3.19 <sup>b</sup> ±0.05	90.89 <sup>e</sup> ±0.02	270.76 <sup>b</sup> ±0.70	75.91 <sup>e</sup> ±0.90	311.84 <sup>e</sup> ±0.92
80:20	0.16 <sup>a</sup> ±0.24	3.65 <sup>b</sup> ±0.01	115.64 <sup>d</sup> ±0.15	269.05 <sup>c</sup> ±0.87	87.65 <sup>d</sup> ±0.75	317.47 <sup>d</sup> ±0.76
70:30	0.17 <sup>a</sup> ±0.06	3.81 <sup>b</sup> ±0.12	123.51 <sup>c</sup> ±0.43	267.42 <sup>d</sup> ±0.61	106.43 <sup>c</sup> ±0.84	326.91 <sup>c</sup> ±0.85
60:40	0.18 <sup>a</sup> ±0.33	4.17 <sup>a</sup> ±0.10	138.48 <sup>b</sup> ±0.22	265.73 <sup>c</sup> ±0.94	114.90 <sup>b</sup> ±0.55	341.27 <sup>b</sup> ±0.98
50:50	0.19 <sup>a</sup> ±0.10	4.43 <sup>a</sup> ±0.05	164.64 <sup>a</sup> ±0.03	264.24 <sup>f</sup> ±0.89	123.27 <sup>a</sup> ±0.63	356.03 <sup>a</sup> ±0.71

Values followed by different superscript in a column are significantly ( $p \leq 0.05$ ) different from each other

The physical properties of batter and cakes prepared from flour blends of wheat-cashew nut kernels are presented in Table 5. The weight (32.25 to 34.30 g) and volume (242.05 to 246.11 cm<sup>3</sup>) of wheat-cashew nut flour cake increased, whereas batter density and volume index of cakes decreased from (0.90 to 0.83) and (103.65 to 99.47) with increasing level of cashew nut kernels flour. However, 100% wheat flour cake had higher batter density, volume and volume index than composite cakes, while the

weight of the former was lower than the latter. The increase in weight and volume of cakes with increasing the level of cashew nut kernels flour in wheat flour may be attributed to low batter density or increased bulk density of flour blends. This is in line with the earlier report of Chinma *et al.* (2007) that weight and volume of snack products depends on bulk density of the flour blends in the product. Also, the increased moisture content of composite cakes as a result of increasing level of cashew nut flour

substitution may be responsible for such increase in weight of composite cake samples. The higher cake volume and of gluten in wheat flour. Gluten (wheat flour protein) is responsible for gas retention and during dough development, it becomes extensive and strong; this allows the dough to rise and also

cake volume index of 100% wheat cake than composite blends may be attributed to the presence

prevents easy escape of the gas during baking thereby resulting to improved physical properties of baked products (Chinma and Gernah, 2007; Akubor *et al.*, 2003).



**Table 5: Physical properties of cakes prepared from flour blends of wheat and cashew nut kernels**

Wheat: cashew nut	Batter density	Cake weight (g)	Cake volume (cm <sup>3</sup> )	Cake volume index
100:0	0.90±0.00 <sup>a</sup>	32.25±0.64 <sup>d</sup>	242.05±0.87 <sup>d</sup>	103.65±0.00 <sup>a</sup>
90:10	0.90±0.01 <sup>a</sup>	32.94±0.43 <sup>c</sup>	243.53±0.69 <sup>c</sup>	102.15 <sup>d</sup> ±0.00 <sup>b</sup>
80:20	0.87±0.00 <sup>a</sup>	33.12±0.45 <sup>b</sup>	243.69±0.68 <sup>bc</sup>	101.00±0.01 <sup>c</sup>
70:30	0.85±0.00 <sup>a</sup>	33.79±0.29 <sup>b</sup>	244.05±0.72 <sup>b</sup>	100.57±0.01 <sup>d</sup>
60:40	0.85±0.01 <sup>a</sup>	33.92±0.36 <sup>b</sup>	245.76±0.80 <sup>a</sup>	100.10±0.00 <sup>d</sup>
50:50	0.83±0.00 <sup>a</sup>	34.30±0.80 <sup>b</sup>	246.11±0.45 <sup>a</sup>	99.47±0.00 <sup>e</sup>

Mean value with different superscript in a column are significantly ( $p \leq 0.05$ ) different from each other

Table 6 presents the sensory properties of cakes prepared from flour blends of wheat and cashew

nut flour. There was no significant ( $p \geq 0.05$ ) difference in crust and crumb colour, crumb grain

texture between wheat cake and composite cakes, but taste and overall acceptability of composite

cakes were significantly different from standard. There was significant difference in texture and

overall acceptability between wheat cake and composite cakes. Addition of cashew nut flour to

wheat increased sensory attribute scores evaluated.

**Table 6: Sensory properties of cakes prepared from flour blends of wheat and cashew nut kernels**

Wheat: cashew nut	Crust colour	Crumb colour	Crumb grain	Texture	Taste	Overall acceptability
100:0	7.53±0.01 <sup>a</sup>	7.72±0.01 <sup>a</sup>	6.95±0.00 <sup>a</sup>	7.15±0.01 <sup>a</sup>	7.20±0.02 <sup>b</sup>	7.03±0.01 <sup>b</sup>
90:10	7.60±0.01 <sup>a</sup>	7.47±0.01 <sup>a</sup>	6.02±0.00 <sup>a</sup>	6.88±0.02 <sup>a</sup>	8.11±0.01	7.96±0.03 <sup>a</sup>
80:20	7.82±0.01 <sup>a</sup>	7.53 <sup>a</sup> ±0.02 <sup>a</sup>	6.17±0.01 <sup>a</sup>	7.10±0.01 <sup>a</sup>	8.17±0.02 <sup>a</sup>	8.18±0.05 <sup>a</sup>
70:30	8.05 <sup>a</sup> ±0.00 <sup>a</sup>	7.58 <sup>a</sup> ±0.01 <sup>a</sup>	6.44±0.01 <sup>a</sup>	7.29±0.03 <sup>a</sup>	8.26±0.01 <sup>a</sup>	7.85±0.01 <sup>a</sup>
60:40	7.97 <sup>a</sup> ±0.00 <sup>a</sup>	7.65±0.00 <sup>a</sup>	6.56±0.03 <sup>a</sup>	7.05±0.01 <sup>a</sup>	8.64±0.03 <sup>a</sup>	8.20±0.01 <sup>a</sup>
50:50	8.11 <sup>a</sup> ±0.02 <sup>a</sup>	7.80±0.00 <sup>a</sup>	6.63±0.01 <sup>a</sup>	7.33±0.03 <sup>a</sup>	8.80±0.02 <sup>a</sup>	8.43±0.03 <sup>a</sup>

Mean value of twenty member panelist

Mean value with different superscript in a column are significantly ( $p \leq 0.05$ ) different from each other.



The increase in sensory scores of wheat-cashew nut kernels cakes could be attributed to addition

of cashew nut kernels flour which imparted good sensory attributes to composite cakes. The

higher texture scores of composite cakes than 100% wheat could be attributed to reduced gluten

content due to substitution of wheat flour with cashew nut kernels flour. This could have resulted

to a soft crumb which is desirable by cake consumers. However, composite cakes was highly

acceptable than 100% wheat cake.

### Conclusion

Based on the outcome of this study, cake with improved chemical, sensory and weight can be

prepared using wheat-cashew nut flour blends up to 50% cashew nut kernels flour substitution;

Cakes prepared from such composite flour could help in combating protein- energy malnutrition

and reduce micro nutrient deficiency prevalent in developing countries such as Nigeria. The low

carbohydrate content of wheat-cashew nut cakes is an indication that such cakes can serve as a

functional food. Wheat-cashew nut kernels cake is recommended for people with protein-energy

and micro-nutrient deficiency.

### REFERENCES

AACC.(2000).Approved methods of the American Association of Cereal Chemists, 17<sup>th</sup> edition.

Akubor, P.I. (2004). Protein contents, physical and sensory properties of Nigerian snack food (cake, Chin-chin and puff-puff) prepared from cowpea-wheat flour blends. *International Journal of Food Science and Technology*, 39, 419–424.

Alozie, Y.A., Udofia, S., Lawal, O. and Ani, I.F. (2009). Nutrient composition and sensory properties of cakes made from wheat and African yam bean flour blends. *Journal of Food Technology*, 7, 115– 118.

AOAC. (2000). Approved methods of the American Association of Cereal Chemists, 17<sup>th</sup> edition, Washington, D.C

Ayo, J. A, Ayo,V. A., Nkama, I. and Adewori, R. (2007). Physicochemical, invitro digestibility and organoleptic evaluation of “acha”-wheat biscuit supplemented with soybean flour. *Nigerian Food Journal*, 25(2):77-89.

Bicalho, B. and Schuch, M.L. (2001). Volatile compounds of cashew (Anacardium occidentale) apple. *Natureforsch*, 56, 35–39.

Chinma, C.E; Abu, J.O and Abubakar, Y.A. (2010).Effect of tigernut (*Cyperus esculentus*) flour addition on the quality of wheat-based cake.*International Journal of Food Science Technology*, 45 (8): 1745-1752.

Chinma, C.E and Gernah, D.I. (2007). Physicochemical and sensory properties of cookies produced from cassava/soyabean/ mango composite flours. *Journal of Raw Materials Research*.4 (1&2): 32-43.

New York. P. 623

*Nigerian Food Journal*, 25(2):77-89.

Steel, R.D.G. and Torrie, J.H (1980). Principle and Procedures of Statistics. A Biometrical Approach. 2nd edn. McGraw Hill Co.



**MICROBIAL EVALUATION OF BOILED EGGS SOLD IN RETAIL OUTLETS IN ZARIA, NIGERIA**

Kolo<sup>1\*</sup>, H. N., E. C. Okolocha<sup>2</sup>, F. U. Samuel<sup>3</sup>, P. S. Kolo<sup>1</sup>, A. A. Banjo<sup>1</sup>, C. E. Ewa<sup>1</sup> and S. O. Azeez<sup>4</sup>

<sup>1</sup>Department of Animal Production, Federal University of Technology, Minna, Nigeria

<sup>2</sup>Department of Public Health and Preventive medicine, Ahmadu Bello University, Zaria, Nigeria

<sup>3</sup>National Animal Production Research Institute, Ahmadu Bello University, Shika-Zaria, Nigeria

<sup>4</sup>Department of Food Science and Nutrition, Federal University of Technology, Minna, Nigeria

\*Corresponding Author's E-mail: [hyacinth.kolo@futminna.edu.ng](mailto:hyacinth.kolo@futminna.edu.ng), [drhy12@yahoo.com](mailto:drhy12@yahoo.com), GSM: 08033847889

## ABSTRACT

One hundred and fifty samples of boiled eggs were collected from three designated sampling areas in Zaria, Nigeria, for the isolation of *Escherichia coli* and *Staphylococcus aureus*, widely known to be contaminants and in some cases pathogens in ready-to-eat foods. Total aerobic plate count was carried out using nutrient agar. The total aerobic plate count ranged from  $1.0 \times 10^9$  to  $7.1 \times 10^{10}$  cfu/g. The average aerobic plate count was  $1.8 \times 10^{10}$  cfu/g. The samples were inoculated on Eosin Methylene Blue (EMB) and staphylococcus 110 agars and the susceptible isolates were subjected to standard biochemical tests and pathogenicity tests for proper biochemical characterization and identification of the pathogens respectively. The results showed that out of 7 suspected isolates of *Escherichia coli* and 9 of the suspected *Staphylococcus aureus* isolates, there were no *Escherichia coli* confirmed in all 7 (100%) isolates and 9(100%) was confirmed as *Staphylococcus aureus*. Therefore, the work shows that boiled eggs can be contaminated and that unsanitary, and unhygienic practices, during preparation and presentation especially cracked shell eggs for consumption can pose serious health hazards.

**KEYWORDS:** *Escherichia coli*, *Staphylococcus aureus*, boiled eggs, food safety.

## INTRODUCTION

There is a growing tendency to eat in places other than the homes and food consumption in restaurants and public eateries (Kinton and Ceserani, 1986; Soriano *et al.*, 2000), as well as road-side ready-to-eat foods which are convenient sources of nourishment available at reasonable costs and sold along road sides, market places, schools and at door steps in Zaria and many other towns in Nigeria (Raji, 2001).

Most of these establishments and places are implicated or considered (by the Health Authority or by consumers) as being implicated in foodborne disease outbreaks (Bryan, 1988; Hedberg *et al.*, 1993; Wienekeet *et al.*, 1993; Igoet *et al.*, 2003).

Foodborne illness is a major public health problem in all developed and developing countries (Akbar and Anal 2014a; Akbar and Anal 2014b). In Nigeria, like most other public health foodborne disease outbreaks, have been attributed to high ambient temperatures, unhygienic surrounding and insanitary manner in which food is hawked and sold in Nigeria predisposes the food to contamination with foodborne micro-organisms (Williams, 1984).

Several foodborne micro-organisms are common contaminants in poultry and livestock products e.g. *Campylobacter* sp., *Salmonella* sp., *Staphylococcus* sp., *Escherichiacoli* (Ghasemian, 2011; Akbar and Anal, 2013a). In case of *Salmonella* infection, egg products were identified as the major food vehicle for outbreaks (CDC, 2000) as well as for sporadic infections (Hedberg *et al.*, 1993; Morse *et al.*, 1994; Trepkaet *et al.*, 1999), though other harmful pathogens are capable of causing foodborne disease outbreaks.

Total Enterobacteriaceae count and total coliforms count are more frequently used to assess enteric contamination and commonly used in slaughterhouses as indicators of faecal as well as environmental contamination (Gonzalez and Domingues, 2006). However, total staphylococci count and *Staphylococcus aureus* counts, which are present on hand, mucous membrane and skin of man, birds and animals, are good indicators of poor personal hygiene, poor handling and temperature control (Rindheet *et al.*, 2008).

Contamination of poultry products with foodborne pathogens remains an important public health issue, where many food poisoning bacteria contaminate chicken meat (Mbata, 2005), eggs and egg products (Kolo, 2009). Therefore, the present study aimed to evaluate the bacteriological quality of boiled eggs sold in retail outlets in Zaria, Nigeria.

## METHODOLOGY

**Study area:** The study was carried out at the bacterial laboratory of the Department of Public health and preventive medicine, Faculty of Veterinary medicine, Ahmadu Bello University, Zaria. The institution is located in Samaru, a suburb of Zaria Nigeria; situated on latitude  $11^{\circ} 12''$  N and longitude  $07^{\circ} 37''$  E, and located in the Northern Guinea Savannah zone of Nigeria.

**Source of experimental samples:** A total of one hundred and fifty samples of boiled eggs were purchased from three designated sampling areas in Zaria, namely: Samaru, Sabon-Gari and Zaria city.



The samples were purchased from the sellers after usual packaging without any prior instruction on mode of packaging.

**Laboratory procedure / analyses of sample:** Ten grams of each of the boiled egg samples was aseptically weighed out using the weighing balance after sterilizing the egg shell with 70% alcohol using a clean cotton wool and then de-shelling with a sterilized forceps (Loongyai, *et al.* 2011). A sterilized pair of scissors was used to cut the products into small pieces and then homogenized with 90ml of 0.1% peptone water in sterile transparent polythene bags using a Stomacher machine (Stomacher L-B 400).

**Total Aerobic Plate Count:** Nutrient agar was used for the total aerobic plate count. A hundred fold serial dilutions were carried out using sterile pipettes to aspirate 0.1mL of the homogenate and 9.9mls of sterile physiological saline solution. Serial dilutions up to  $10^{-9}$  were carried out. Aliquots of 0.1mL of the  $10^{-9}$  dilution were usually inoculated on to nutrient agar plates and spread uniformly using sterile glass spreaders (Hockey sticks). The plates were incubated at  $37^{\circ}\text{C}$  for 24 hours, after which the colonies were counted.

**Isolation of *Escherichiacoli*:** About 0.1mL of the initial homogenate at  $10^{-3}$  dilution was inoculated onto separate Eosin-Methylene Blue agar plates and spread using sterile glass spreaders. The plates were appropriately labelled and incubated at  $37^{\circ}\text{C}$  for 24 hours. The plates were observed for colonies with characteristic greenish metallic sheen on Eosin-Methylene Blue agar plates. A loopful of the suspected *E. coli* was picked and sub cultured on nutrient agar slants for further confirmatory tests.

**Biochemical Characterization:** The suspected *E. coli* isolates were subjected to biochemical characterization using Triple Sugar Iron agar (TSI), Simmon's citrate agar, Sulphide Indole Motility agar (SIM), Urease agar and Methyl Red Vogues Proskaur broth for their various reactions.

**Isolation of *Staphylococcus aureus*:** A volume of 0.1mL of the initial homogenate at  $10^{-2}$  dilution was inoculated onto Staph 100 agar plates using sterile glass spreaders. The plates were appropriately labelled and incubated aerobically for 24 hours at  $37^{\circ}\text{C}$ . Growths which appeared as round, smooth creamy white to yellowish colonies were suspected as *Staphylococcus aureus* colonies. The colonies obtained were identified using Gram staining technique. The isolates were streaked on nutrient agar

slants and stored in the refrigerator for further analyses.

**Pathogenicity Test for *Staphylococcus aureus*:** To confirm the presence of pathogenic *Staphylococcus aureus*, catalase and coagulate tests were conducted.

For the catalase test, a loopful of the growth was picked from the nutrient agar slant and emulsified with a drop or two of hydrogen peroxide on a clean glass slide. Appearance of bubbles of gas signified positive reaction to catalase test.

For the coagulase test, a drop of physiological saline was dropped on a clean glass slide with the aid of a sterile inoculating loop. The loop was then used to pick the growth of the suspected *Staphylococcus aureus* isolate from the nutrient agar slant. The isolates were emulsified in drops of normal physiological saline on clean glass slide. Two drops of human plasma were added and mixed with the emulsified isolate. The mixture was observed for clumping or agglutination.

**Statistical analysis:** Microbial counts (CFU/g) were represented as  $\log_{10}$  CFU/g and Means were calculated. Microbial counts were compared by ANOVA using SPSS Software 13.0.

## RESULTS AND DISCUSSION

**Isolation of *Escherichiacoli* from boiled eggs:** Growths of suspected *Escherichiacoli* were observed on 7(4.6%) out of the 150 samples cultured on Eosin-Methylene Blue. The growths had flat surface with blackish centre and a greenish metallic sheen.

Out of the 7 suspected *Escherichiacoli* isolates, there were no positive results to confirm *E. coli* following the biochemical tests (Table 1).

**Isolation of *Staphylococcus aureus* from boiled eggs:** Growths of the suspected *Staphylococcus aureus* isolates were observed on 9(6%) out of the 150 samples (Table 2) cultured on Staph10 agar. The growths appeared round, smooth creamy-white to golden yellow with convex appearance. Gram staining of the suspected isolates revealed gram-positive cocci in clusters, like grapes, with purple appearance.

**Catalase and Coagulase tests:** All the 9(100%) suspected isolates were catalase positive, and coagulase positive hence confirming the presence of *Staphylococcus aureus* (Table 2).

**Total Aerobic Plate Count:** The mean  $\log_{10}$  total aerobic plate count ranged from 9.0 to 10.9  $\log_{10}$  cfu/g with an overall mean of 10.3  $\log_{10}$  cfu/g. The

colonies were small to medium-sized, rounded and smooth, with a creamy to yellowish colouration on nutrient agar (Table 3).

Exogenic contamination of eggs (also termed horizontal contamination), by far more frequent than vertical contamination in terms of overall levels and diversity of bacteria, corresponds to the contamination of the egg (Baron and Jan, 2011) after the egg defense system such as cuticle, calcium egg shell and shell membrane (Jerzy and Dagmara, 2009; Chaemsanitet *et al.*, 2015) have been bridged.

Egg can be contaminated at both egg shell and egg contents by a variety of microbes including *Escherichia coli* and *Staphylococciaureus* (Board and Tranter, 1995; Rickeet *et al.*, 2001). *Staphylococci* are most common bacteria contaminating egg shells. Contamination is more likely linked with cracked egg, dirty shells and storage in contaminated surroundings. This agrees with our findings for the presence of *Staphylococciaureus* across all the sampled areas in Zaria.

From the study, the total aerobic plate count ranged from  $1.0 \times 10^9$  to  $7.1 \times 10^{10}$  cfu/g and the average aerobic plate count was  $1.8 \times 10^{10}$  cfu/g. This agrees with other reported level of eggshell contamination by mesophilic aerobic microbiota ranges from  $10^{3.8}$  to  $10^{6.3}$  cfu/egg, with an average of around  $10^{4.5}$  cfu/egg (Moats, 1980; Lucoret *et al.*, 1997; Favieret *et al.*, 2000; Jones *et al.*, 2004; De Reuet *al.*, 2005, 2006a; Musgrove *et al.*, 2005). De Reuet *al.* (2006a) also observed a predominance of *E coli* ( $5.5 \times 10^4$  cfu/egg), and *Staphylococcus* ( $4.3 \times 10^4$  cfu/egg), thus indicative of contamination of boiled eggs with aerobic microbes through various sources of contamination.

## CONCLUSION AND RECOMMENDATIONS

This study shows that boiled eggs sold in Zaria, Nigeria, are capable of a relative contamination with foodborne micro-organisms which can pose a threat to consumer's health due to unsanitary and unhygienic locations as well as egg and egg product handlers are culpable to varying levels of contamination. It is recommended that:

1. Boiled eggs especially with a cracked shell should not be purchased and consumption of raw or undercooked eggs should be avoided so that they do not serve as medium for transmission of foodborne pathogens.
2. An enlightenment campaign should be carried out to educate food handlers and consumers on the need for proper personal hygiene practices to minimize contamination.

## ACKNOWLEDGEMENTS

Authors wish to thank the Department of Public Health and Preventive medicine, Ahmadu Bello University, Zaria, Nigeria for the research support.

Table 1: Isolation of *Escherichiacoli* in boiled eggs sold in retail outlets in Zaria, Nigeria

Sampling area	Total number of samples examined	Number of samples with suspected growth (cfu/g) and percentage	No. of samples positives for <i>E. coli</i>
1 Samaru	50	7(14%)	0
2 Sabon-Gari	50	0(0%)	0
3 Zaria city	50	0(0%)	0

Table 2: Isolation of *Staphylococcus aureus* in boiled eggs sold in retail outlets in Zaria, Nigeria

Sampling area	Total number of samples examined	Number of samples positive for <i>S. aureus</i> and percentage
1 Samaru	50	4(8%)
2 Sabon-Gari	50	3(6%)
3 Zaria city	50	2(4%)

Table 3: Total Aerobic Plate count (TAPC) of boiled eggs sold retail outlets in Zaria, Nigeria

Sampling area	Total number of samples examined.	Number of samples with growth observed (cfu/g), the percentage and Standard Deviation.	Mean log <sub>10</sub> of TAPC (cfu/g).	Range of log <sub>10</sub> TAPC (cfu/g).
1 Samaru	50	47(94%)± 16.3	10.3	9.3-10.9
2 Sabon-Gari	50	45(90%)± 17.3	10.3	9.0-10.8
3 Zaria city	50	49(98%)± 9.7	10.0	9.0-10.6

#### REFERENCES

Akbar, A. & Anal, A. K. (2013a). Prevalence and antibiogram study of *Salmonella* and

*Staphylococcus aureus* in poultry meat. *Asian Pacific Journal of Tropical Biomedicine*, 3(2): 163-168.



- Akbar, A. & Anal, A. K. (2014a). Occurrence of *Staphylococcus aureus* and evaluation of anti-staphylococcal activity of *Lactococcus lactis* subsp. *lactis* in ready-to-eat poultry meat. *Annals of Microbiology*, 64(1): 131-138.
- Akbar, A. & Anal, A. K. (2014). Zinc oxide nanoparticles loaded active packaging a challenge study against *Salmonella typhimurium* and *Staphylococcus aureus* in ready- to-eat poultry meat. *Food Control*, 38: 88-95.
- Board, R. G. & Tranter, H. S. (1995). The microbiology of eggs. In: W. J. Stadelman and Cotterill O. J. (Eds). *Egg Science and technology*. 4th edition. Haworth Press Inc. New York.
- Bryan, F. L. (1988). Risk associated with Practice, Procedure and Process that lead to Outbreaks of Food Borne disease. *Journal of Food Protection*, 51:663-673.
- Centre for Disease control and Prevention- CDC (2000). Outbreaks of Salmonella and other pathogens infections Associated with Eating Raw or undercooked shell Eggs. *United States, 1996-1998 Morbidity Mortal weekly Report*, 49: 73-79.
- Chaemsanit, S., Akbar, A. & Anal, A. K. (2015). Isolation of total aerobic and pathogenic bacteria from table eggs and its Contents. *Food and Applied Bioscience Journal*, 3 (1): 1-9.
- De Reu, K., Grijspeerdt, K., Heyndrickx, M., Zoons, J., De Baere, K., Uyttendaele, M., Debevere, J. & Herman, L. (2005). Bacterial eggshell contamination in conventional cages, furnished cages and aviary housing systems for laying hens. *British Poultry Science*, 46(2): 149-155.
- De Reu, K., Grijspeerdt, K., Heyndrickx, M., Uyttendaele, M., Debevere, J. & Herman, L. (2006a). Bacterial shell contamination in the egg collection chains of different housing systems for laying hens. *British Poultry Science*, 47(2): 163-172.
- Favier, G. I., Escudero, M. E., Mattar, M. A., & de Guzman, A. M. (2000). Survival of *Yersinia enterocolitica* and mesophilic aerobic bacteria on eggshell after washing with hypochlorite and organic acid solutions. *Journal of Food Protection*, 63(8): 1053-1057.
- Ghasemian, S. (2011). The prevalence of bacterial contamination of table eggs from retail markets by *Salmonella* spp., *Listeria monocytogenes*, *Campylobacter jejuni* and *Escherichia coli* in Shahrekord, Iran. *Jundishapur Journal of Microbiology*, 4(4): 249-253.
- Gonzalez-Fandos, E. & Dominguez, J. L. (2006). Efficacy of lactic acid against *Listeria monocytogenes* attached to poultry skin during refrigerated storage. *Journal of Applied Microbiology*, 101 (6): 1331-1339.
- Hedberg, C.W., David, M. J., White, K. E., MacDonald, K. L. & Osterholm, M. T. (1993). Role of Egg consumption in sporadic *Salmonella enteritidis* and *Salmonella typhimurium* infections in Minnesota. *Journal of Infectious Diseases*, 167:107-111.
- Jerzy, R. & Dagmara, S. P. (2009). Antimicrobial defense mechanisms of chicken eggs and possibilities for their use in protecting human and animal health. Division of avian diseases, Institute of biological bases of animal diseases University of life sciences in Lublin.
- Jones, D. R., Musgrove, M. T. & Northcutt, J. K. (2004). Variations in external and internal microbial populations in shell eggs during extended storage. *Journal of Food Protection*, 67(12): 2657-2660.
- Kinton, R. & Ceserani, V. (1886). The theory of catering, 5<sup>th</sup> Edition, Hodder and Stoughton, London, pp 2-3.
- Kolo, H. N. (2009). Total Counts and Isolation of *Escherichia coli* and *Staphylococcus aureus* from boiled eggs sold in retail outlets in Zaria, Nigeria. A DVM Final year thesis, Ahmadu Bello University, Zaria, pp 2.
- Lucore, L., Jones, F., Anderson, K. E. & Curtis, P. A. (1997). Internal and external bacterial counts from shells of eggs washed in a commercial-type processor at various wash-water temperatures. *Journal of Food Protection*, 60(11): 1324-1328.
- Loongyai, W., Wiriya, B. & Sangsawang, N. (2011). Detection of *Salmonella* and *Escherichia coli* in egg shell and egg content from different housing systems for laying hens. *International Journal of Poultry Science*, 10(2): 93-97.
- Mbata, T. I. (2005). Poultry meat pathogens and its Control. Department of Applied Microbiology and Brewing .Nnamdi Azikiwe University, P.M.B 5025 .Awka Nigeria. *Internet Journal of Food Safety*, 7: 20-28.
- Moats, W. A. (1980). Classification of bacteria from commercial egg washers and washed and unwashed

eggs. *Applied Environmental Microbiology*, 40(4): 710-714.

- Morse, D. L., Birkhead, G. S., Guardino, J., Kondracki, S. F. & Guzewich, J. J. (1994). Outbreak and sporadic egg-associated cases of *Salmonella enteritidis* - New York experience. *American Journal Public Health*, 84: 859-860.
- Musgrove, M. T., Jones, D. R., Northcutt, J. K., Cox, N. A. & Harrison, M. A. (2005). Shell rinse and shell crush methods for the recovery of aerobic microorganisms and enterobacteriaceae from shell eggs. *Journal of Food Protection*, 68(10): 2144-2148.
- Raji, K. B. (2001). Total Aerobic Plate count and isolation of *Staphylococcus aureus* in some selected Ready-to-eat road-side food in Zaria, Nigeria. A DVM Final year thesis, Ahmadu Bello University, Zaria, pp 1.
- Ricke, S. C., Birkhold, S. G. & Gast, R. K. (2001). Eggs and egg products. In compendium of methods for the microbiological examination of foods, 4th edition. Downes, F. P. & Ito, K. (Eds). American Public Health Association, Washington, D.C, pp. 473-479.
- Rindhe, S. N., Zanjad, P. N., Doifode, V. K., Siddique, A. & Mendhe, M. S. (2008). Assessment of microbial contamination of chicken products sold in Parbhani city. *Veterinary World*, 1(7): 208-210.
- Soriano, J. M., Manes, J., Rubert, J. V., & Sospedra, I. (2000). Microbial contamination of Milk and Dairy Products from Restaurants in Spain. *Journal of Foodborne Pathogens and Disease*, 2(2): 138-11.
- Trepka, M. J., Archer, J. R., Altekuse, S. F., Procter, M. E. & Davis, J. P. (1999). An Increase in Sporadic and Outbreak – associated *Salmonella enteritidis* Infection in Wisconsin: The role of eggs. *Journal of Infectious Diseases*, 180: 1214-1219.
- Wieneke, A. A., Roberts, D. & Gilbert, R. J. (1993). Staphylococcal food poisoning in the United Kingdom, 1969-1990. *Epidemiology of Infection*, 110: 519-531.
- Williams, B. (1984). Problems of food poisoning and infection in Nigeria. The Medical Microbiological Aspects. *Nigeria Food Journal*. 2(1): 93-94.

# INFLUENCE OF WATTLE ON HAEMATOLOGY AND SERUM BIOCHEMISTRY OF RED SOKOTO BUCKS KEPT SEMI-INTENSIVELY IN NIGER STATE, NIGERIA

Kolo<sup>1\*</sup>, P. S., Alemede, I.C., Egena, S. S. A. and Adama, J. Y.

Department of Animal Production, Federal University of Technology, Minna, Niger State, Nigeria.

Corresponding Author: [kolo.philip@futminna.edu.ng](mailto:kolo.philip@futminna.edu.ng) GSM: 07035071871

## ABSTRACT

*A study aimed at assessing the influence of wattle on haematology and serum biochemistry was carried out on eight Red Sokoto bucks in Niger State, Nigeria. The experiment lasted six months within which data was collected on haematology (Red blood cell, White blood cells, PCV, Neutrophils Lymphocytes. Haemoglobin, Mono, Eos, Baso, MCV, MCH and MCHC) and serum biochemistry (ALB, ALP, Na, Ca, Total protein, Urea, Creat, K, Trigy, Cl, Total bid, Conjbid, Phos, Choles, HDL, LDL, Glucose, SGOT and SGPT). Data obtained were subjected to statistical package (SAS, 2000). At the end, wattle had significant influence ( $p < 0.05$ ) the white blood cells neutrophils, lymphocytes and HDL. Bucks without wattle had higher white blood cells and lymphocytes than wattled bucks which might have resulted from an active viral infection stress or other abnormalities. Bucks with wattle had higher HDL, which lowers blood cholesterol level.*

**KEYWORDS:** wattle, buck, haematology, biochemistry, red sokoto

## INTRODUCTION

Wattle is the cartilaginous tissue surrounded by dense fibrous connective tissue hanging on the neck of some ruminants (Robert, 1994). Wattle possession in goats could either be present or absent. When present, could vary in number, shape and position. It is speculated that the expression of wattle traits in goats may represent some adaptive mechanisms related to adaptation and survival in different ecological zones (Odubote, 1994). Several research findings (Casu et al. 1970; Osinowo et al. 1988; Shongjia et al. 1992; Ozoje, 2002; Ozoje and Mgbere, 2002) have reported some positive associations between wattle traits and livestock performances, namely; growth, reproduction and heat tolerance Adedeji (2011) worked on the effect of wattle on haematology in West African Dwarf goats. Information on effect of wattle on red Sokoto breed of Nigeria, especially on the role of wattle on haematology and serum biochemistry of red sokoto goat is scarce. This study will therefore focus on the effect of wattle on haematology and serum biochemistry of Red sokoto bucks raised semi intensively in Niger state.

## METHODOLOGY

### Location of study

The study was conducted at the ruminant unit of the teaching and research farm, School of Agriculture and Agricultural Technology, Federal University of Technology, Gidan Kwano Campus, Minna, Niger State. Minna is located at the Southern Guinea savanna zone on the Latitude (90-36 and 90-50

North) and longitude (60-33 and 60-25 East) (NSADP. 1995).

### Source of Experimental Animals

The Red Sokoto bucks used for the study were purchased from Mariga, Kanfaninbobi and Bida goat markets in Niger State.

### Management of Experimental Animals / Experimental Design

The eight red sokoto bucks were allotted to two (2) treatments groups. Treatment 1 contained bucks without wattle. Treatment 2 of contained bucks with wattle. The animals were given routine treatment using prescribed dose of penstrep, oxytetracycline, ivometin and multivitamins. Vaccination against PPR was also given. The bucks were managed under a semi-intensive system. The animals were provided feed supplement such as Maize bran/offal, Beans husk, and Guinea corn shaft and mango leaves. Animals were also left to graze freely on natural rangeland daily from 10:00 am until 6:00 pm in the evening after which they are returned to the pen. The bucks were tagged using rope and well label plastic material for identification. The experiment lasted for six months (March - August).

### Data Collection

Blood samples was collected from the bucks three times (beginning, middle and at the end of the experiment). At each point, 5ml of blood sample was collected using 5ml syringe, 2.5 ml was dispensed into plain (anticoagulant free) while 2.5 ml was dispensed into Ethylene Diamine Tetra acetic Acid



(EDTA) bottle and labeled appropriately. The blood samples were transported in ice pack to the laboratory for analysis (haematology and serum biochemistry).

#### **Statistical Analysis**

Data collected was analyzed using SAS statistical package (SAS, 2000). Duncan's Multiple Range Test, Duncan (1955) was used to determine the significant differences ( $p < 0.05$ ) among treatments. means.

#### **RESULTS AND DISCUSSION**

The haematology result shown in table 1 revealed a significant difference ( $p < 0.05$ ) in the white blood cells neutrophils and lymphocytes. Wattle had no significant effect ( $p > 0.05$ ) on red blood cell, Haemoglobin, PCV, Monocytes, Eosinophils, Basophils, MCV, MCH and MCHC of the bucks used. The high level of white blood cells and lymphocytes in bucks without wattle might be due presence of infection or a toxic substance in the body of the does. According to Veterinary Drug Handbook (2009), active viral infection stimulates the immune system to produce higher levels of white blood cells and lymphocytes. Higher WBC is an indicator of immune response to infections or toxic substances in the organism (Bradbury *et al.*, 1999). Etim (2013) stated that over the upper limits of white blood cell (leukocytosis) indicates problem, these could include; stress, infection, allergy, inflammation, trauma, or certain diseases. Therefore, a high white blood cell count requires further investigation. Braun (2013) reported that a high white blood cell count could be caused by stress, immune system disorders, and infection among others. In other studies, it was reported that a high number of leucocytes may be due to anaemia, bone marrow tumour, infectious diseases inflammatory disease, severe physical stress, tissue damage (for example, burns) among others (Bagby, 2007).

The serum biochemistry as presented in Table 2. Shows that wattle did not significantly influence the ALB, ALP, Na, Ca, Total protein, Urea, Creat, K, Trigy, Cl, Total bid, Conjbid, Phos, Choles, LDL, Glucose, SGOT and SGPT of male except the HDL ( $p > 0.05$ ).

Bucks with wattle had significantly higher ( $p < 0.05$ ) HDL than those without wattle. HDL, which stands for high-density lipoprotein (HDL), is called 'good' cholesterol, as it takes cholesterol out of cells and the blood and helps to prevent excess cholesterol. This prevents poor circulation of blood, which can lead to stroke, high blood pressure, kidney damage and other heart diseases (Waugh, 2008).

#### **CONCLUSION AND RECOMMENDATIONS**

##### **Conclusion**

The study identified higher white blood cell count above the recommended range, which suggest active infection, toxicity, trauma, stress or other anomalies inbucks without wattle.

In addition, bucks with wattle had higher HDL, which brings about lower blood cholesterol levels.

##### **Recommendation**

There is need to conduct further studies to determine the effect of wattle on immune system and blood cholesterol.

**Table 1. Haematology of the bucks used**

Parameters	Range (Daramola <i>et al.</i> , 2005)	T1	T2	SEM
Red Blood Cell(x106/dl)	9.2 -13.5	10.20	10.19	0.17
Haemoglobin (g/dl)	7 – 15	8.85	9.79	0.39
Packed Cell Volumes(%)	21- 35	29.58	31.47	1.32
Mean Corpuscular Volume(fl)	16-25	37.20	37.40	0.32
Mean Corpuscular Haemoglobin(pg)	5.2-8.0	6.55	6.43	0.40
Mean Corpuscular Haemoglobin Concentration(g/dl)	30 – 36	36.81	37.22	0.80
White Blood Cell(x 103/l)	6.8 -20.1	15.58 <sup>a</sup>	12.53 <sup>b</sup>	0.76
WBC Differentials				
Lymphocytes(%)	47 – 82	65.53 <sup>a</sup>	60.41 <sup>b</sup>	1.31
Neutrophils(%)	17 – 52	32.30 <sup>b</sup>	37.05 <sup>a</sup>	0.98
Eosinophils(%)	1 – 7	2.00	1.20	0.41
Monocytes(%)	0-4	0.47	0.32	0.14
Basophils(%)	0-1	0.20	0.40	0.15

a b c d Means within a row having different superscripts differed significantly (P<0.05)

T1= Bucks without wattle

T2= Wattled Bucks

**Table 2. Serum biochemistry of the bucks used**

Parameters	Range (Daramola <i>et al.</i> , 2005)	T1	T2	SEM
Albumin (g/dl)	2.8 – 4.3	2.85	2.72	0.32
Alkaline Phosphatase (Iu/ml)	1.4-25.7	312.1	261.5	52.14
Sodium (mmol/ml)	-	153.6	160.53	3.66
Calcium (mmu/L)	1.15 – 2.4	2.7	2.81	0.11
Total Protein (g/dl)	6.3 – 8.5	6.14	6.33	0.45
UREA( mmu/L)	0.8 – 9.7	7.73	8.00	0.81
Creatinine (mg/dl)	0.9 - 1.8	1.2	1.19	0.23
Potassium mmu/L	3.0 – 6.0	6.21	5.72	0.38
High Density Lipoprotien (mmu/L)	-	0.47 <sup>b</sup>	1.00 <sup>a</sup>	0.11
Chloride (mmu/L)	105 – 120	66.52	72.44	11.43
TOTALBilirubin (mg/dL)	0 - 0.9	2.9	3.83	0.35
Conjugated Bilirubin (mg/dl)	-	1.2	1.37	0.12
Phosphorus (mmu/l)	0.58 – 4.5	2.35	2.3	0.22
Cholesterol (mmu/L)	64.6 - 136.4	5.025	5.38	0.71
Low Density Lipoprotein (mmol/L)	-	1.3	1.75	0.28
Glucose (mmu/L)	-	2.59	2.66	0.6
SGOT (IU/L)	Dec-38	31.37	26.41	4.1
SGPT (IU/L)	2 – 22	15.49	13.82	2.89

abcd Means within a row having different superscripts differed significantly (P<0.05)

T1= Bucks without wattle

T2= Wattled Bucks

## REFERENCES

Adedeji,T.A., Ozoje, M.O., Peters,S.O., Sanusi, O.A.,Ojedapo, L.O.& Ige, A.O. (2011). Coat

- pigmentation and Wattle Genes' effect on some Haematological Characteristics of Heat Stressed and Extensively Reared West African Dwarf Goats. *World Journal of Life Science and Medical Research*. 1(3):48-55.
- Bagby, G. C. (2007). Leucopenia and leucocytosis. In: Goldman L. Ausiello D, eds. *Cecil Medicine*. 23rd ed. Philadelphia. Pa: Saunders Elsevier, 173.
- Bradbury, M. G; Egan, S. V and Bradbury, J. H (1999). Determination of all forms of Cyanogen in cassava Roots and cassava Products Using Picrate paper kits. *J.S. Clinical cases of Small ruminants in Zaria, Nigeria. Bulletin of Animal Health and Production in Africa* 30, 111-116. 15.
- Braun, P. (2013). High white blood cell count. What you should know? Inside Tracker. Available at: Bunn, H. F. (2011). Approach to the anaemias. In: Goldman, L., Schaffer, A. I. eds. *Cecil Medicine*. 24th ed. Philadelphia, Pa: Saunders Elsevier, 161.
- Casu S., Boyazoglu J.G. and Lauvergne J.J. (1970). The Inheritance of wattles in the Sardinian breed of sheep. *Anal. Genet. Sel. Anim.* 2, 249-261.
- Etim, N. N., Enyenihi, G. E., Williams, M. E. Udo, M. D., and Offiong, E. E. A. (2013) Haematological Parameters: Indicators of the Physiological Status of Farm Animals. *British Journal of Science*. Vol. 10 (1). 33 December © 2013 British Journals ISSN 2047-3745
- NSADP. (1995). Niger State Agricultural Development Project. 31st quarterly report, January March. In: *Nigerian Agro –Newsletter*. July- December, 2, 32-33.
- Odubote I.K. (1994). Influence of qualitative traits on the performance of West African Dwarf goats. *Nigerian J. Anim. Prod.* 21, 25-28.
- Osinowo O.A., Buvanendran V. and Koining M.L. (1990). The Occurrence and inheritance of Wattles in Yankasa sheep. *Nigerian. J. Anim. Prod.* 17(1/2), 63-64.
- Ozoje M.O. (2002). Incidence and relative effects of qualitative traits in West African Dwarf goats. *Small Rumin. Res.* 43, 97100.
- Ozoje M.O. and Mgbere O.O. (2002). Coat pigmentation effects in West Africa Dwarf goats: Live weights and body dimensions. *Nigerian. J. Anim. Prod.* 29(1), 5-10.
- Robert A.V. (1994). Raising Healthy Goats under Primitive Conditions, Overview of General Information, Pp. 12-18. Christian Veterinary Mission, Washington, U.S.A.
- Shongjia L., Xiangmo L., Gangyl X. and Shenov C. (1992). Relationship between physical traits, litter size and milk yield in Saanen, Guanzhong and Crossbred goats. Pp. 83 in *Proc. 5th Int. Conf. Goats*. New Delhi
- Veterinary Drug Handbook, D.C. Plumb, Iowa State University Press, 1999.
- Waugh, DJ and Wilson, C. (2008). "The interleukin-8 pathway in cancer". *Clinical Cancer Research*. 14 (21): 6735–41.



# INFLUENCE OF CLIMATE CHANGE ON THE LENGTH OF GROWING SEASON IN MINNA, NIGER STATE (2006-2016)

Rita Edoga and Lukman Animashaun

Dept of Soil Science & Land Management, SAAT, FUT, Minna – Nigeria  
+2347018613725, [edogarita@yahoo.com](mailto:edogarita@yahoo.com)

**Abstract:** Ten years climatic data (daily, monthly and annual) collected from A.B.U, Zaria were computed and statistically analyzed using Correlation. The annual temperature and rainfall were determined by summing up the monthly temperature, rainfall and the whole twelve months added together each respectively, for every year. The duration of growing season was determined by subtracting, for each year, the date at which the rains started from the date that it ended. Pearsons product moment correlation analysis was used to determine the relationship between temperature, rainfall and growing seasons. The results of this analysis were shown in Tables and Figures. The ten years data (2006 – 2016) from Institute for Agricultural Research (IAR), Ahmadu Bello University (ABU), Zaria were used to compute the data for temperature and rainfall. The data for temperature and rainfall were computed and were compared statistically using correlation analyses showing that temperature and rainfall change has significant effect on growing season.

**Keywords:** Climate change, length of growing season

## INTRODUCTION

The growing season is the part of the year during which local weather condition (i.e rainfall and temperature) permit normal plant growth. While each plant or crop has a specific growing season that depends on its genetic adaptation. Geographical conditions have major impacts on the growing season for any given area. The elevation or the height above sea level, and temperature of region are two of the main factors that affect the growing season (McMichaels AJ, Kovats RS ,2014). Generally speaking, the distance a location is from the equator can be a strong indicator as to what the growing season will look like, however in a high elevation area, regardless of proximity to the equator, a shorter growing season will generally be experienced. Proximity to the ocean also can create less extreme condition, especially in terms of temperature, which has the potential to extend the growing season further in either direction. In hotter climate, particularly in deserts, despite the geographic barrier of limited water source, people have been able to extend their growing season in these regions by way of diverting water from other areas and using it in their agriculture. The ability to use these irrigation methods, despite geographic challenges, has made it possible to enjoy almost a year-round growing season (Miller, C. and Edwards, P.N., 2001).

Climate change, also called global warming, refers to the rise in average surface temperature on earth. An overwhelming scientific consensus maintains that climate change is due primarily, to the human use of fossil fuels, which release carbon dioxide and other

greenhouse gases into the air. Climate change is perhaps the most serious environmental threat to agricultural production in Nigeria. The effects of climate change are dependent on latitude, altitude, type of crop grown and livestock reared. The direct impact of climate change on agricultural systems are: changes in rainfall pattern and temperatures which could impact on agro-climatic conditions, altering growing seasons, planting and harvesting calendars, water availability, pest, weed and disease populations. Climate change would also impact on alteration in evapotranspiration, photosynthesis, biomass production and land suitability for agricultural production (Walter 1970). There was also increase in the intensity of the rains. Measures mitigating the impact of climate change and adaptation have been identified to include: human capital development, increase funding of research and technology development, breeding short duration varieties, draining lowland rice fields to reduce emission of methane, nitrous oxide and carbon dioxide (greenhouse gases), agro forestry, soil and water conservation and trade (Fischer, 2005).

Climate change is the latest challenge to sustainable human development. The scientific evidence is clear, climate change is likely to have negative impacts on efforts to achieve Nigeria's development objectives, including the targets set out in Nigeria Vision 20:20202 and the Millennium Development Goals (MDGs). In particular, climate change will impede efforts to reduce the poverty experienced by the majority of

Nigerians. It will retard the drive to ensure equity in the distribution of development benefits, particularly among women and men; as well as to check the effort to promote sustainable livelihoods. In addition, climate change will likely lead to other changes such as ecosystem degradation and reduced availability of water and food. It is therefore likely to become a major driver of increased human conflict. Climate change is already having an impact in Nigeria. Weather-related disasters have become more frequent in the past four decades and the trend continues (NEMA, 2010).

**LENGTH OF GROWING SEASON**

The duration of the growing season can be determined by subtracting, for each year, the date at which the rains start from the date that it ends. A growing season is the period of the year when crops and other plants grow successfully. The length of a growing season varies from place to place. Most crops need a growing season of at least 90 days.

In tropical regions, where it is warm year-round, the growing season can last the entire year. In some tropical places, however, the growing season is interrupted by a rainy season. During this time, it is too wet to grow crops. Coffee, which grows in tropical climates, has this type of varied growing season.

In other tropical places, it is sometimes too dry for crops to grow. The tropical region of northern Africa, called the Sahel, experiences frequent periods of drought. The Sahel is a transition zone between the Sahara Desert in the north and the Savanna in the south. Due to dramatic weather patterns, the prospect of a successful harvest in the Sahel is highly uncertain.

Therefore, the objectives of this research are:

- (i) To determine the influence of climate change (temperature and rainfall) on the duration of growing season in Minna, Southern Guinea Savanna of Nigeria from 2006 to 2016.
- (ii) To compare the various year growing seasons.

**2. MATERIALS AND METHODS**

The research was carried out at the Teaching and Research Farm of the School of Agriculture and Agricultural Technology, Federal University of Technology Minna, Niger State, Nigeria. Located in the Southern Guinea Savanna vegetation zone of Nigeria (latitude 9° 41' N and longitude 6° 31' E; 258.5 m above sea level). Climate of Minna is sub

humid with mean annual rainfall of about 1284 mm and a distinct dry season of about 5 months occurring from November to March. The mean maximum temperature remains high throughout the year, about 33.5°C particularly in March and June (Ojanuga, 2006).

Evapo-transpiration is highest in the month of March; this is also the month when dry season is at its peak. Due to the high temperature during this period, there is more water loss from the earth surface and from plant cells. In the other way rounds, least evapo-transpiration occurs in the month of August, which is also the month at which rainy season is at its peak in the zone. (Edoga and Suzzy, 2008).

**DATA SOURCE:** Climatic data were collected from Institute for Agricultural Research (IAR), Ahmadu Bello University (ABU), Zaria. Ten years of daily data (2006 – 2016) were used. The climatic data available at the station include temperature, relative humidity, wind speed, rainfall, sunshine hours and radiation. Data collection will be done by department well trained staff.

**ANALYSIS OF THE DATA:** The annual temperature was determined by summing up the monthly temperature and the whole twelve months added together for every year. The annual rainfall was determined by summing up the monthly rainfall and the whole twelve months added together for every year. The climatic data (daily, monthly and annual) were analyzed using Correlation.

**LENGTH OF GROWING SEASON:** The duration of growing season was determined by subtracting, for each year, the date at which the rains started from the date that it ended.

**Correlation analysis:** The ten years climatic data of temperature, rainfall and length of growing season were statistically analysed using correlation analysis. The results are presented on Table 1.

**3. Results**

The results are presented on Tables 1,2, 3 and Figures 1, 2, 3

**CORRELATION**

Pearsons product moment correlation analysis was used to determine the relationship between temperature, rainfall and growing seasons. The results of this analysis was shown in Table 1.0

Table 1.0: Correlation analysis (2006 – 2016)

Years	Temp	Rainfall	Length of growing season
2006	0.091	0.081	0.773**
2007	0.029	0.010	0.965**
2008	0.041	0.005	0.968**
2009	0.104	0.004	0.945**

2010	0.090	0.042	0.973**
2011	0.283	0.264	0.971
2012	0.110	0.187	0.943**
<b>YEARS</b>	<b>AMOUNT OF RAINFALL IN (MM)</b>		
2006	1088.5		
2007	1093.1		
2008	1175.1		
2009	1278		
2010	1127.3		
2011	931.3		
2012	1333.3		
2013	1028.8		
2014	1067.9		
2015	1135.9		
2016	1128.5		
2013	0.035	0.036	0.918**
2014	0.230	0.129	0.879**
2015	0.051	0.005	0.909**
2016	0.253	0.012	0.922**

Table 2: Annual Rainfall Pattern (2006 – 2016)

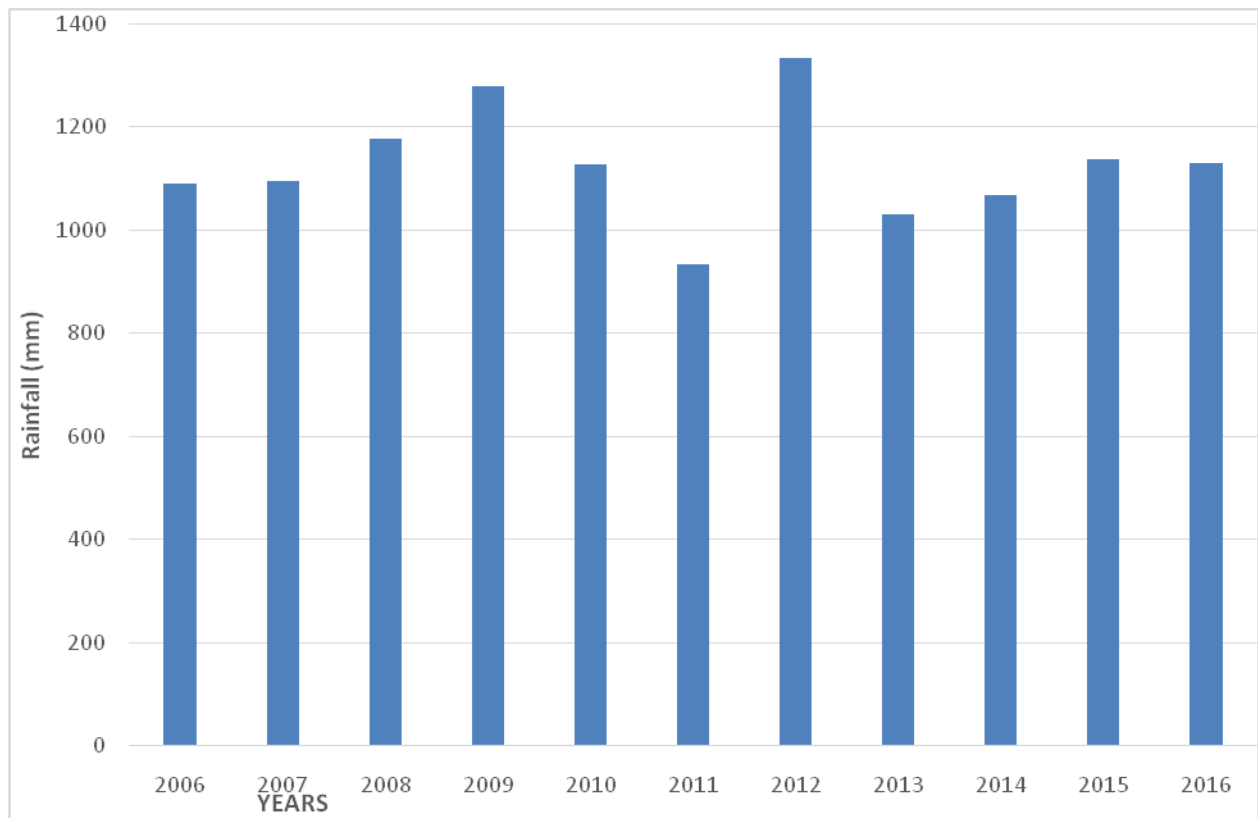
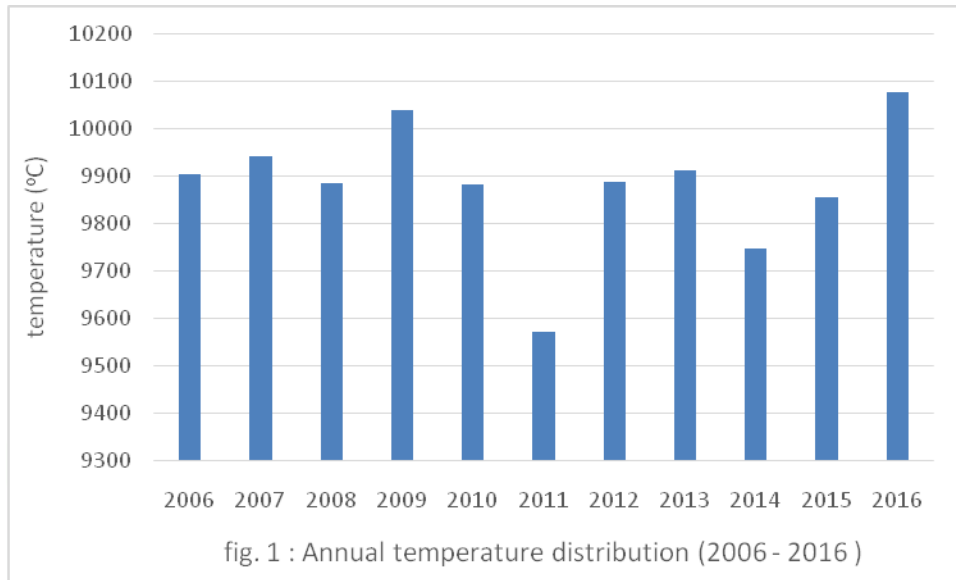


Fig. 2: ANNUAL RAINFALL DISTRIBUTION (2006 - 2016)

#### 4.2 TEMPERATURE

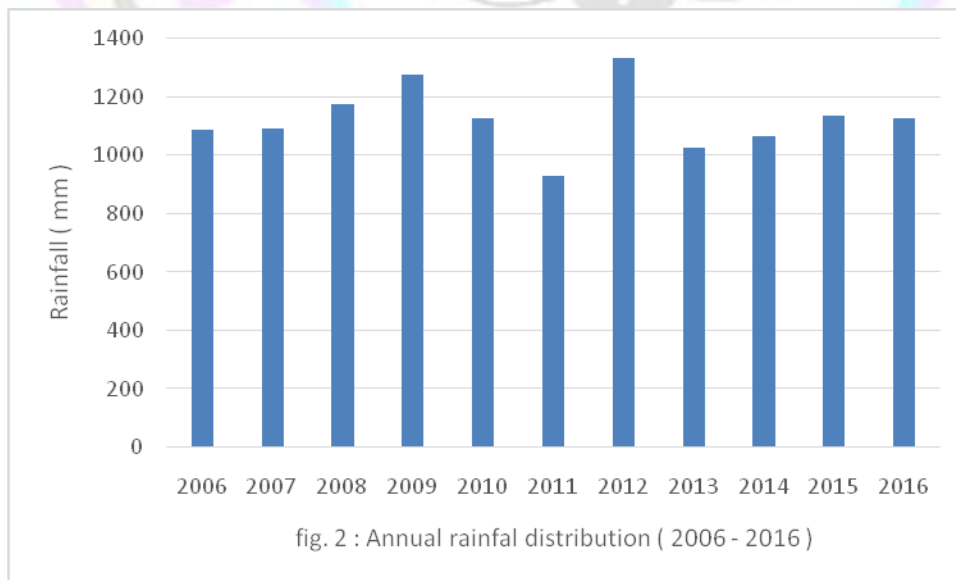


The amount of annual temperature distribution during the eleven years (2006- 2016) is shown in figure 1.



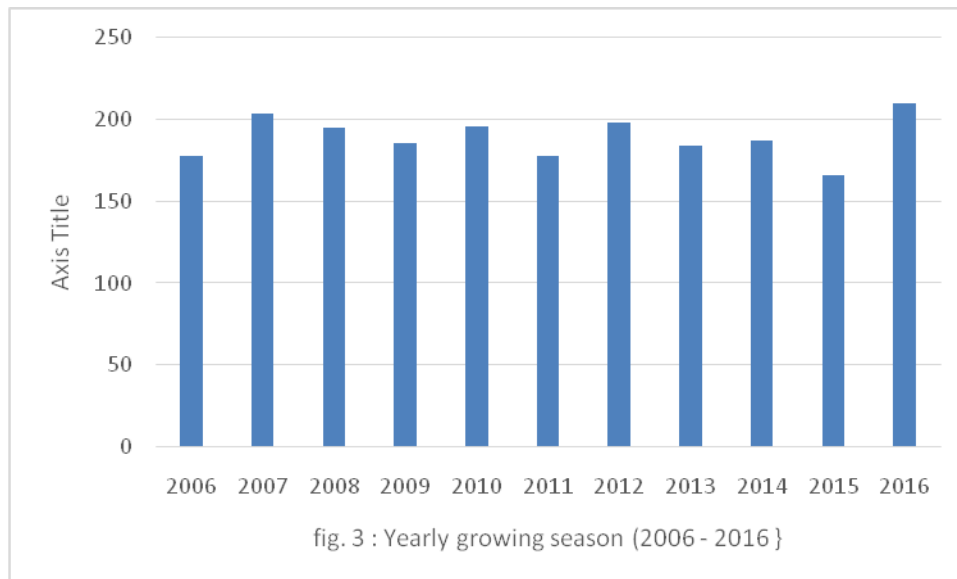
#### 4.3 RAINFALL

The amount of annual rainfall distribution during the eleven years (2006 – 2016) period is shown in figure 2.



#### 4.4 GROWING SEASON

The length of annual growing season during the eleven years (2006 – 2016) period is shown in figure 3



#### 4. Discussion

2006, 2011 and 2015, with growing season days of 198, 196, 195, 187, 186, 184, 178, 178 and 166 days respectively. The year 2015 has the least growing season. This is shown in Figure 3. Growing season depends on rainfall and temperature, if there is increase in temperature and decrease in rainfall this will affect the length of growing season. Also if there is increase rainfall and decrease in temperature this will also affect the length of growing season. The year 2016 has the longest growing season because of high temperature and high rainfall. Also in the year 2015 which has the lowest growing season this as a result of high rainfall and low temperature. Table 1.0 shows that growing season strongly correlate with rainfall. It depends so much on rainfall, as rainfall increases, the length of growing season increases also. The growing season is inversely affected by temperature, but high temperature simulates rainfall. Table 2 shows that 2012 has the highest value of rainfall (1333.3 mm) this was due to increase in atmospheric temperature of the Northern Guinea Savanna, followed by 2009 which has a rainfall value of (1278 mm). much differences were not notice between 2015 and 2016, while 2011 has the lowest rainfall value of (931.3 mm).

#### 5. Conclusion and Recommendations

This research work was carried out to investigate the influence of temperature and rainfall on the length of growing season. The ten years data (2006 – 2016) from Institute for Agricultural Research (IAR), Ahmadu Bello University (ABU), Zaria was used to compute the data for temperature and rainfall. The data for temperature and rainfall were computed and were compared statistically using correlation analyses showing that temperature and rainfall change has significant effect on growing season.

Climate change has also affected the atmospheric temperatures which has adverse effect on the fluctuation of the rainfall pattern in guinea savannah, leading to flood within the northern hemisphere of the country .

#### References

Fischer G (2005). Socio-economic and climate change impacts on agriculture: an integrated assessment 1990 –2080. Philosophical Transactions of the Royal Society 360:2067- 2083.

Miller, C. and Edwards, P.N., 2001: Changing the Atmosphere. Expert Knowledge and Environmental governance, MIT press. National Geographic 2014.

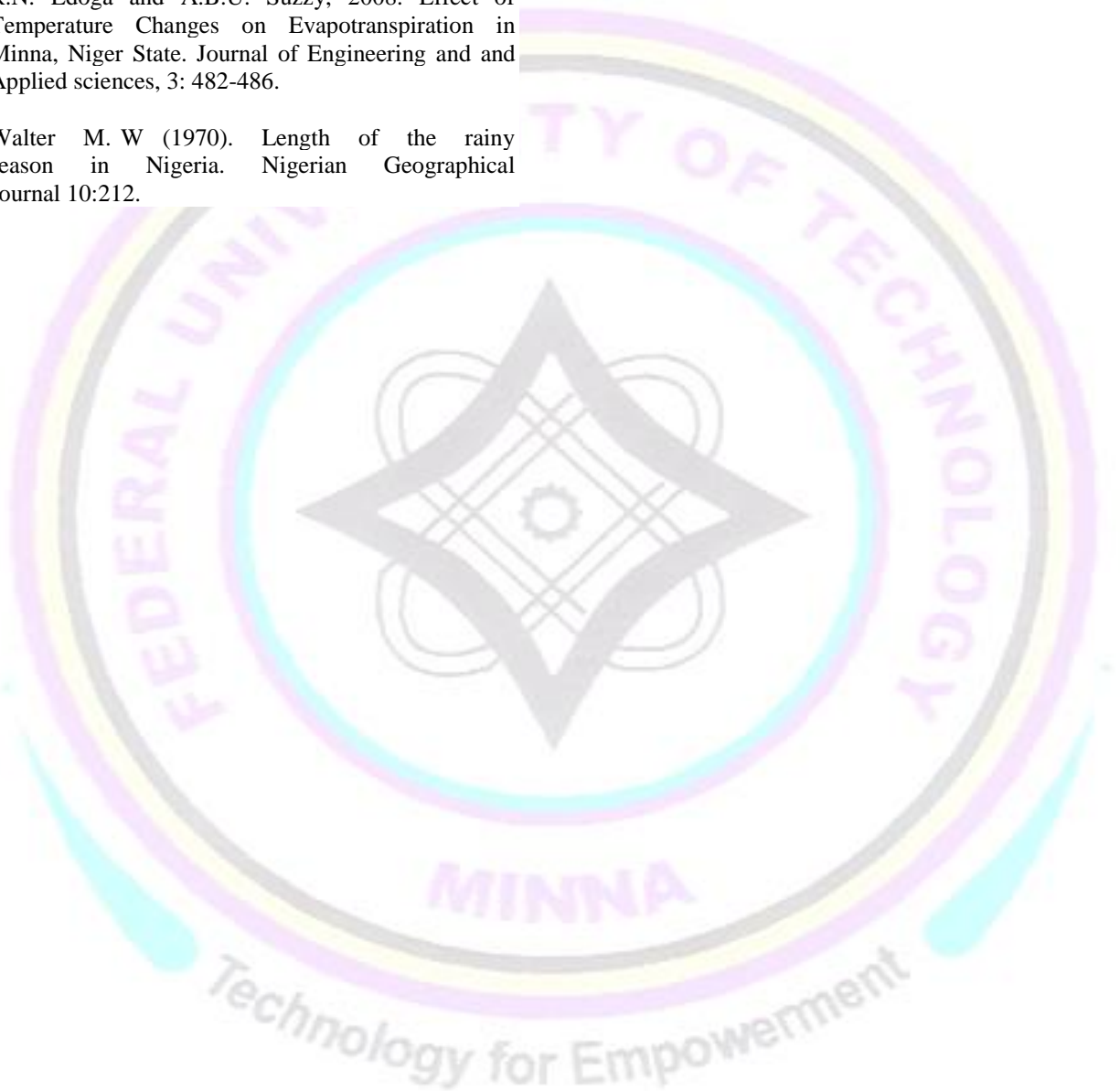
NEMA (2010). Daily trust newspaper 14 th October 2010.

Ojanuga, A.G. (2006) Agroecological Zones of Nigeria Manual. In: Berding, F. and chude, V.O., Eds., National Special Programme for Food Security (NSPFS) and FAO, 124.

Pebly AR. Demography and the Environment. Demography 1998;35:377–89.

R.N. Edoga and A.B.U. Suzzy, 2008. Effect of Temperature Changes on Evapotranspiration in Minna, Niger State. Journal of Engineering and Applied sciences, 3: 482-486.

Walter M. W (1970). Length of the rainy season in Nigeria. Nigerian Geographical Journal 10:212.





# PERFORMANCE OF FUNAAB ALPHA BROILER CHICKENS FED DIFFERENT DIETARY ENERGY LEVELS UNDER A SINGLE PHASE FEEDING

Akigbogun\*, K.I., Alemede, I.C. and Egena, S.S.A.

*Department of Animal Production, School of Agriculture and Agricultural Technology  
Federal University of Technology, Minna, Niger State, Nigeria.*

## ABSTRACT

*A twelve week feeding trial was conducted to investigate the performance characteristics of FUNAAB Alpha broiler chickens fed diets containing different energy levels. One hundred and ninety-eight broiler chickens were randomly allotted to four dietary treatments in a randomized complete block design with 3 replicates containing 16 chicks each. The experimental diets contain four varying dietary energy at levels of 2899.76, 2954.85, 3094.80 and 3166.38 kcal/kg ME. The experimental diets were designated T<sub>1</sub>, T<sub>2</sub>, T<sub>3</sub> and T<sub>4</sub>, respectively with crude protein content of 18%. Data collected on feed intake, weight gain, feed conversion ratio and carcass characteristics were subjected to analysis of variance using SAS statistical software. The results revealed that there were significant ( $P < 0.05$ ) difference in the final body weight, feed intake and body weight gain of the birds influenced by the feeding of different energy levels while no significant ( $P > 0.05$ ) difference was observed in the feed conversion ratio and efficiency ratio of the birds. Carcass characteristics evaluated were not affected ( $P > 0.05$ ) by the experimental treatment. It was concluded that FUNAAB Alpha broiler chickens perform better at dietary energy level of 3094.80 kcal/kg ME.*

**Keywords:** Indigenous chicken, FUNAAB Alpha chickens, Energy  
E-mail: akioo1962@yahoo.com 08052627289

## INTRODUCTION

The indigenous chickens are considered to be of low productivity in terms of poor growth rates, few eggs produced, high mortalities, susceptibility to disease and long brooding period. Pedersen (2002), Sonaiya and Swan (2004) and Lwelamira (2007) reported that indigenous chickens are characterized by low productivity due to factors such as low genetic potential, poor management practices and high prevalence of disease. This has caused declines in the number of indigenous chickens (Ben Larbi *et al.*, 2013), and an increase in commercially produced poultry meat and eggs from exotic poultry breeds (Gueye, 2003). To maximize the potential of indigenous chickens in order for them to be able to meet the current high demand for poultry meat and eggs in the country, optimum production energy has to be provided. In order to improve and maximize productivity, the optimal nutritional requirements of the FUNAAB Alpha broiler chickens needs to be known, particularly energy (bases for feed formulation) and crude protein. The dearth of information on the optimal energy requirement that will warrant growth and good carcass characteristics of the FUNAAB Alpha broiler chickens is the reason why the current study is being undertaken. Results emanating from the research will shed more light on the optimum energy requirement of the birds. This

will be of vital interest to farmers as it may have implications on the profitability of their enterprise.

## MATERIALS AND METHODS

The experiment was carried out at the poultry unit of the Teaching and Research Farm of the Department of Animal Production, Federal University of Technology, Minna, Niger State, Nigeria.

### Experimental Animals and Management

One hundred and ninety-eight (198) day old FUNAAB Alpha broiler chicks were used for the experiment. They were randomly allotted to four (4) treatments in a completely randomized design. Each treatment was replicated three times giving 16 birds per replicate. Feed and water were provided *ad libitum*. Prior to the arrival of the birds, the pens were subjected to thorough washing with disinfectant (Izal® solution), followed with scrubbing, cleaning, removal of debris and cobwebs. Fresh wood shavings were spread to a depth of 3 cm and other appliances such as pilot light, drinkers, feeders and heating source from charcoal for brooding were provided. The chicks were brooded for two (2) weeks. During the course of rearing, the birds were vaccinated against Gumboro, Newcastle and Fowl pox disease. Prophylactic antibiotics and coccidiostat with electrolytes or antistress were also administered.

### Preparation of Full-fat soyabean.

The anti nutritional factor in the soyabean was removed using cooking method. The raw soyabeans were cleaned by removing stones and thereafter pour into aluminium pot containing 50 litres of water. 50 kg of soyabean were pour into water and then allow to cook at 80 °C for 30 minutes according to the method described by Kaankuka *et al.*(1996).The cooked soyabean was then allowed to cool and dried before grinding.

### Experimental Diets

The treatments were four diets varying in dietary energy levels of 2899.76, 2954.85, 3094.80 and 3166.38 kcal/kg ME and labelled T<sub>1</sub>, T<sub>2</sub>, T<sub>3</sub> and T<sub>4</sub>, respectively (Table 1) with crude protein content of 18 % (isonitrogenous).

### Parameters Measured

Parameters measured were body weight, body weight gain, feed intake, feed conversion ratio and energy efficiency ratio. Carcass parameters evaluated include: live weight, slaughtered weight, dressed weight, dressing percentage and weights of some cut-up parts (breast, back, wings, shanks and drumstick). The experiment lasted for 12 weeks.

### Data Analysis

Data generated were subjected to analysis of variance using SPSS software (SPSS, 2015) and means were separated using Duncan's Multiple Range Test. Significant differences were considered at 5% level of probability.

## RESULTS AND DISCUSSION

The effect of feeding varying dietary energy levels on the growth performance of FUNAAB Alpha broiler chickens is presented in Table 2. There were

significant (P<0.05) differences in the final body weight, body weight gain and feed intake of the birds among the treatments. Birds fed treatment T<sub>4</sub> having energy level of 3166.38 had significantly (P<0.05) lower body weight gain than birds fed with treatment T<sub>2</sub> and T<sub>3</sub> with energy levels of 2954.85 and 3094.80, respectively. However, birds fed treatment T<sub>2</sub> (2899.76 kcal/kg ME) had comparable body weight gain as birds fed treatments containing 2954.85, 3094.80 and 3166.38kcal/kg ME, respectively. The result agrees with the reports of Khobondo *et al.* (2015) who opined that, at 18% crude protein level, increasing dietary energy from 2800 to 3000 kcal/kg ME resulted into a 42 g decrease in weight gain.

There were marked (P<0.05) variations in the feed intake among the treatments. Birds fed with energy level of 3166.38 kcal/kg ME had significantly (P<0.05) reduced feed intake compared to birds fed the other energy levels. There were no significant (P>0.05) differences in feed conversion ratio and energy efficiency of the birds among the treatments. These findings strengthened the earlier reports of Nahashon *et al.* (2005) that as dietary energy level increases, birds satisfy their energy needs by decreasing feed intake. Another report (Leeson, 2000; Veldkamp *et al.*, 2005) supported the assertion that there is a decrease in feed intake with high energy levels in the diets of broiler chickens. In contrast to the above observation, Araújo (1998) reported that there is no effect of dietary metabolizable energy concentration on feed intake between two groups of broiler chickens fed *ad-libitum* diets containing two energy levels of energy; 13.38 and 15 MJ ME/kg dry matter.

Table 1: Ingredient composition of experimental diets (%)

Ingredient	T <sub>1</sub>	T <sub>2</sub>	T <sub>3</sub>	T <sub>4</sub>
Maize	29.95	33.00	54.00	64.25
Maize Offal	39.50	36.00	14.25	3.00
Full fat soya	20.80	22.25	23.00	24.00
Fish meal	3.00	3.00	3.00	3.00
Methionine	0.25	0.25	0.25	0.25
Lysine	0.75	0.75	0.75	0.75
*Premix	0.50	0.50	0.50	0.50
Bone meal	3.00	3.00	3.00	3.00
Oyster shell	1.00	1.00	1.00	1.00
Salt	0.25	0.25	0.25	0.25
Total	100	100	100	100
Calculated analysis				
Crude protein (%)	17.90	18.00	17.98	18.08
Energy (kcal/kg ME)	2899.76	2954.85	3094.80	3166.38

Crude fibre (%)	5.03	4.86	4.47	4.77
Lysine (%)	1.11	1.12	1.10	1.05
Methionine (%)	0.33	0.34	0.31	0.30
Calcium (%)	1.74	1.74	1.72	1.64
Phosphorus (%)	0.81	0.81	0.77	0.75
Ether Extract (%)	3.09	3.12	3.12	3.24

\*Each 2.5kg HI-Mix® vitamin/mineral premix contain: Vitamin A= 7,500,000 IU, Vitamin D3=1,000,000 IU, Vitamin E=1,800mg, Vitamin K=700mg, Vitamin B1= 500mg, Vitamin B2=1,800mg, Vitamin B6=180mg, Niacin=4,000mg, Vitamin B12=5mg, Pantothenic acid=3,200mg, Folic acid=50mg, Choline chloride=63,000mg, Manganese=35,000mg, Zinc=15,000mg, Iron=10,000mg, Copper=1,500mg, Iodine=720mg and Cobalt=180mg.

The carcass characteristic of FUNAAB Alpha broiler chickens as affected by the feeding of different energy levels is presented in Table 3. The results revealed no significant ( $P>0.05$ ) effect of the treatment on the carcass characteristics of the FUNAAB Alpha broiler chickens. Although no significant effect was observed, birds fed treatment 3 (3094.80 kcal/kg ME) had better carcass scores in all the parameters evaluated with the exception of dressing percentage and wings. The dressing

percentage value obtained showed that birds fed treatment 2 (2954.85 kcal/kg ME) had the highest value of 60.36%, while birds in treatment T4 (3166.38 kcal/kg ME) had the lowest dressing percentage of 57.54%. The results obtained agrees with the reports of Missohou *et al.* (2002) and FAO (2004) that indigenous chickens are known to be slow growing with a low carcass weight. The low carcass weight had implication on the other carcass cuts and dressing percentage.

Table 2: Effect of feeding varying dietary energy levels on growth performance of FUNAAB Alpha broiler chickens

Parameter	T <sub>1</sub>	T <sub>2</sub>	T <sub>3</sub>	T <sub>4</sub>	SEM
Initial weight (g)/bird	39.72	39.09	40.07	40.52	0.10
Final weight (g)/bird	0.001 <sup>a</sup>	0.011 <sup>a</sup>	0.001 <sup>a</sup>	0.0782 <sup>b</sup>	11.58*
Final body weight gain (g)/bird	77.00 <sup>ab</sup>	87.52 <sup>a</sup>	84.09 <sup>a</sup>	57.44 <sup>c</sup>	4.34*
Feed intake (g)	0.0033 <sup>c</sup>	0.0036 <sup>c</sup>	0.0322 <sup>a</sup>	0.0249 <sup>ab</sup>	13.67*
Feed conversion ratio	5.37	5.23	4.59	5.30	0.29ns
Energy efficiency ratio	0.0001	0.0001	0.0001	0.0001	0.00001ns

abc=Means with different superscripts in the same row are significantly different ( $P<0.05$ ), SEM=standard error of mean, ns=not significant ( $P>0.05$ )

Table 3: Effect of feeding varying energy levels on the carcass characteristic of FUNAAB Alpha broiler chickens

Parameter	T <sub>1</sub>	T <sub>2</sub>	T <sub>3</sub>	T <sub>4</sub>	SEM
Live weight (g)	1350.00	1483.30	1500.00	1116.70	69.39ns
Eviscerated weight (g)	1300.00	1416.70	1450.00	1066.70	68.76ns
Dressing %	56.75	60.36	58.98	57.54	1.03ns
Wing (%)	10.40	10.31	9.74	9.32	0.42ns
Drumstick (%)	10.09	9.56	10.35	9.73	0.25ns
Breast (%)	12.37	14.00	12.80	13.08	0.42ns
Back (%)	12.78	12.82	13.62	12.70	0.23ns
Shank (%)	10.77	10.26	11.38	10.19	0.44ns

SEM=standard error of mean, ns=not significant ( $P>0.05$ )

## CONCLUSION

Based on the obtained results, it can be concluded that the FUNAAB Alpha broiler chickens performed



better when fed at dietary energy level of 3094.80 kcal/kg ME and 18% crude protein under a single phase regime.

## REFERENCES

- Araújo, L.F. (1998). Avaliação do desempenho e rendimento de carcaça de frangos de corte submetidos a dietas com altos níveis de energia, metionina+cistina e lisina na fase final de criação [dissertação]. Jaboticabal (SP): UNESP.
- Ben Larbi, M., M'hamdi, N. and Haddad, B. (2013). Indigenous chicken production systems in villages in the south of Tunisia. *Livestock Research for Rural Development* 25, 99–105.
- FAO (2004). Food and Agriculture Organization of the United Nations. Banques De Données, Faostat: Agriculture.
- Gueye, E.F. (2003). Production and consumption trend in Africa. *World Poultry* 19: 12-14.
- Kaankuka, F.G. Balogun, T. F. and Tegbe, T. S. B. (1996). Effect of duration of cooking of full-fat soyabans on proximate analysis, level of anti-nutritional factors and digestibility by weaning pigs. *Animal Feed Science Technology*, 62: 229-237
- Khobondo, J.O., Muasya , T.K., Miyumo, S., Okeno, T.O., Wasike, C.B., Mwakubambanya, R., Kingori, A.M. and Kahi, A.K (2015). Genetic and nutrition development of indigenous chicken in Africa. *Livestock Research for Rural Development* 27, Article #122.
- Leeson, S. (2000). Is feed efficiency still a useful measure of broiler performance? Department of Animal and Poultry Science, University of Guelph, Ministry of Agriculture, Food and Rural Affairs, Canada.
- Lwelamira, J. (2007). Prospects for improving chicken performance among two local chicken ecotypes of Tanzania through selection. Ph.D thesis, Sokoine University of Agriculture, Morogoro, Tanzania.
- Missohou, A., Dieye, P.N. and Talaki, E. (2002). Rural poultry production and productivity in southern Senegal. *Livestock Research for Rural Development* 14: 2
- <http://www.cipav.org.co/lrrd/lrrd14/2/miss142.htm>
- Nahashon, S.N., Adefope, N., Amenyenu, A. and Wright, D. (2005). Effect of dietary metabolisable energy and crude protein concentrations on growth performance and carcass characteristics of French guinea fowl broilers. *Poultry Science Journal* 84: 337-344 growth phase. *Livestock Research for Rural Development, Volume 27, Article #204* .
- Pedersen, C.V. (2002). Productivity of semi-scavenging chickens in Zimbabwe. Ph.D thesis. The Royal Veterinary and Agricultural University (RVAU), Copenhagen, Denmark.
- SPSS(2015). Statistical package for the Social Science
- Sonaiya, E.B. and Swan, S.E.J. (2004). Small-scale poultry production technical guide. Food and Agriculture Organization of the United Nations. Animal production and health manual. Rome 2004.
- Veldkamp, T., Kwakkel, R.P., Ferket, P.R. and Verstegen, M.W.A. (2005). Growth response to dietary energy and lysine at high and low ambient temperature in male Turkeys. *Poultry Science Journal* 84: 273-282.

## CLIMATE ADAPTATION MEASURES BY IFAD-VCDP RICE FARMERS IN WUSHISHI LOCAL GOVERNMENT AREA, NIGER STATE, NIGERIA.

Jirgi, A. J.<sup>1</sup>, J. G. Tuedogheye<sup>1</sup>, A. O. Simon<sup>1</sup>, A. I. Oseghale<sup>1</sup>

<sup>1</sup>Department of Agricultural Economics and Farm Management, School of Agriculture and Agricultural Technology, Federal University of Technology, Minna, P.M.B 65, Minna, Niger State, Nigeria.

## ABSTRACT

*Change in Climate is one of the major global environmental glitches threatening the survival of the entire human race. It is a global threat with serious negative results on agriculture, natural ecosystem, water supply, health, soil and atmosphere, which are all elements that institute the support for long term sustainability of life on earth. The variation in climate parameters affect different sectors of the economy such as agriculture, health, water, resources, energy etc. this main cause of climate change has been attributed to human activities. This study describes the socio-economic characteristics and examines the determinants of climate change adaptation strategies used by IFAD-VCDP farmers in the study area. The results of the study are expected to give direction for policy makers in designing appropriate policies to increase climate adaptation measure in Wushishi LGA. It will provide a useful guide to international and local donor agencies interested in climate adaptation in their provision of grants and funds for environmental and resource management studies. Researchers will also find the outcome of the study relevant in a bid to expand the frontiers of knowledge. A multi-stage sampling procedure was used to select 120 rice farmers from a total of 173 rice farmers in the LGA using the Yamane's formula at 5% limit or tolerable error. The farmers were male, married and have a mean age of 34 years. The years of farming experience was 23 years. The majority of the farmers cultivate less than five hectare as reveal by a mean farm size of 1.04ha. The result from the multinomial logit revealed that farm income, the number of years in school and years in farming were positively significant. Income from farm activities and years in farming were positively significant and had positive marginal effect on probability of choosing and using various adaptation strategies while household size was negatively significant. It is therefore recommended that government provide basic amenities such as hospital, market and credit facilities.*

**KEYWORDS:** Climatic adaptation, IFAD –VCDP, Rice, Niger state

## INTRODUCTION

Change in Climate is one of the major global environmental problems threatening the survival of the entire human race. It is a global threat with serious negative results on agriculture, natural ecosystem, water supply, health, soil and atmosphere, which are all elements that constitute the support for long term sustainability of life on earth (Emeka, 2008). Ikehi and Zimoghen (2015) also defined Climate change is the variation in the statistical distribution of the average weather conditions over a prolong period of time. Climate change refers to weather changes, including steady alteration in usual temperature (rise or fall), rainfall pattern or intensity), wind, relative humidity and solar radiation over time. The variation in climate parameters affect diverse sectors of the economy such as agriculture, health, water, resources, energy etc. this main cause of climate change has been accredited to human activities. Agriculture is therefore the main perpetrator of climate change producing significant effects through the production and release of GHGs. Climate change is one of the most serious environmental threats facing mankind. It affects agriculture in several ways, one of which is its direct impact on food production.

Adaptation is defined as “decision-making processes and actions” that enhance enabling conditions for adaptation (Eisenack and Stecker, 2010). Climate

adaptation refers to organized methods through which people and societies adjust to changes in climate, thereby making changes in the operation and use of natural resource by systems and other forms of social and economic organizations (Quan and Dyer, 2008).

Crop yield are affected by many factors resulting from climate change which include temperature, rainfall, and other extreme weather events. Adapting to climate change entails taking the right measures to reduce the negative effects of climate change (or exploit the positive ones) by making the appropriate adjustments and changes (UNFCCC, 2007). Adaptation therefore aims at reducing vulnerability to climatic change and vulnerability of communities, regions, and nations to climate variability.

Rice farming is highly dependent on environmental factors which are the most important among several factors that influence agricultural production. Edeh *et al.* (2011) stated that rice production depends on optimum combination of production inputs in order to achieve remarkable yield. These inputs are both the familiar production inputs and the various environmental factors provided by nature such as rainfall characteristics (intensity and duration), relative humidity and temperature constitute. As reported by Manneh *et al.* (2007), rice when compared with other crops is very sensitive to



drought which can reduce stand establishment, tillering, plant height, spikelet fertility and also delay flowering. The degree of impact on drought however, is dependent on the stage of growth of the crop. Nguyen (2004) also noted that the growth pattern, duration and productivity of rice crop is greatly influenced by temperature while severe moisture stress especially during rice reproductive stage may lead to complete crop failure.

The Value Chain Development Program is a Federal Government Programme was inaugurated by International Food for Agricultural Development (IFAD) in 2015. The programme is for rice and cassava farmers for improving cassava and rice value chains for small farmers in the six states namely Anambra, Benue, Ebonyi, Niger, Ogun and Taraba State. The programme is aimed at enhancing the economic status of small -holders' farmers in the rural areas over a period of six years. The programme will strengthen farmers' organization, opportunities and overcome constraints along the value chain through the use of smart technologies. The goal of the programme is to reduce rural poverty, increase food security and accelerate economic growth on a sustainable basis.

A prolonged period of insufficient or excessive rainfall, a sudden hot spell or cold snap, climatic extremes such as flooding or storms, can have a significant influence on local rice yields. In Nigeria, farmers are facing problem of extreme weather events such as floods, droughts and low soil fertility which are responsible for low rate of rice production (Arimi, 2014). Existing adaptation strategies may not work under future changes and consequently more work on adaptation preparedness would be required. Although several studies have been conducted on climate change and adaptations (Ayoade, 2012; Ifeanyi-Obi *et al.*, 2012; Otitoju, 2013), little empirical knowledge exist on the climate adaptation measures by IFAD/ FGN/ VCDP rice farmers.

It is against this backdrop that the study describe the socio-economic characteristics and examine the determinants of climate change adaptation strategies used by IFAD-VCDP farmers in the study area. The results of this study are expected to give direction for policy makers to designing appropriate public policies to increase climate adaptation measure in Wushishi LGA. The study will also provide a useful guide to international and local donor agencies interested in climate adaptation in their provision of grants and funds for environmental and resource management studies. Researchers will also find the outcome of the study relevant in a bid to expand the frontiers of knowledge.

## METHODOLOGY

### Study Area

The study was undertaken in in Wushishi, Local Government Area in Niger State, Nigeria Niger State is located between Latitudes 8°22'N and 11°30'N and Longitudes 3°30'E and 7°20'E. Wushishi local government area has an area of 1,879 km<sup>2</sup>, density of 51.6inh/km and a population of 81,783 at the 2006 census. The towns include: Dagbaiko, Ashishi, Barwa, Begi, C-ekun. Kanko e.t.c and the town is known for enormous farming activities. The State covers a total land area of 74.244sq.km, which is about 8% of Nigeria's total land area. This makes the State the largest in the Country. The population of the State is 3,950,249, comprising 2,082,725 males and 1,867,524 females (National Population Commission (NPC), 2006). The projected population of the State as at 2016 was 5,556,200 (United Nations Population Fund (UNFPA), 2016). The average annual rainfall in the State is 1,219 mm. The dry season is between November and March. Temperature is fairly regular and ranges from 26.1°C (June – February) to 30.3°C (March – April). The soil types support sustainable production of arable crops. Major crops cultivated include rice, guinea corn, maize, yam, beans, groundnut, and sugarcane ([www.nigerstate.gov.ng](http://www.nigerstate.gov.ng)). The State has large water bodies (River Niger and River Kaduna) with numerous tributaries, as well as lakes and dams which make it suitable for the cultivation of irrigated crops such as rice, vegetables. Livestock rearing and fishing activities are also prevalent in the State (International Rice Research Institute (IRRI), 2000).

### Sample Design, Techniques and Sample Size

#### Sample Selection

A multi-stage sampling procedure was used to select respondents for this study. In the first stage, one local government area was selected (Wushishi LGA) in Niger State. Second stage, four (4) villages were purposively selected because of their predominance in rice production in the local government area (Table 1). The third stage, involved random selection of a total of 120 rice farmers from a total of 173 rice farmers in the LGA using the Yamane's formula at 5% limit or tolerable error.

### Method of Data Collection and Management

Primary data was used for the study. Primary data was collected using a well-structured questionnaire to be administered on the respondents by the researcher and team of extension agents involved in IFAD - VCDP program in Niger state. Information on some



socio- economic variables such as Input output data on production was also be collected.

### Model Specification

Descriptive statistics and multinomial logit regression was employed to analyse the data from field survey.

The multinomial logit model is specified in equation 1:

$$Y_i = \beta_0 + \beta_1 X_1 + \beta_2 X_2 + \beta_3 X_3 + \beta_4 X_4 + \beta_5 X_5 + \beta_6 X_6 + \beta_7 X_7 + \beta_8 X_8 + \beta_9 X_9 + \beta_{10} X_{10} + e \quad (1)$$

Where  $Y_i$  = Adaptation strategies (Change crop variety and Build water conservation scheme = 1, Implement soil conservation scheme and use of chemical fertilizer = 2, Seeking early warning information and changing planting date = 3, Reduce number of livestock and diversity from farming to non-farming activity = 4).

$X_1$ = Farm Income (Naira);

$X_2$ = Age of Farmer (years);

$X_3$ = Household Size (Number);

$X_4$ = Source of capital (1= own savings, 0 = other sources)

$X_5$ = Years in school (Years);

$X_6$ = Years in farming (Years);

$X_7$ = Farm size (ha);

$X_8$ = Access to credit (1= yes, 0= No)

$X_9$ = Off farm income (Naira)

$B_0$  = Intercept

$\beta_1 - \beta_8$  = Coefficients to be estimated

$e$  = error term

## RESULTS AND DISCUSSION

### Socio economic characteristics of the farmers

Figure 1 reveal that majority 90.8% of farmers were male while only 9.2% were females. This shows that males dominated the crop production activities in the study area. This agrees with the findings of Akintonde *et al.* (2016), Ayoade (2012) and Defeng *et al.* (2017) who asserted that rice production were dominated by male. Ifeanyi-Obi *et al.* (2013) disagree with this assertion. Figure 2 show that 92.5% of the total farmer were married, while the remaining 7.5% were single. This may determine availability of labor in traditional agricultural economics. Furthermore,

figure 3 showed that the mean age was 34 years with most of the respondents 48.3% within the age range of 31 - 40 years which indicates an agriculturally active age bracket while 23.3% of the respondents were within the age of 41- 50 years. The age of the farmers determine the quality and quantity of work he or she can do on his her respondents were within the agriculturally active age bracket. This is in agreement with the finding of Ifeanyi-obi *et al.* (2013). Also, figure 4 show that the mean household size of 6 persons with 32.5% of respondents having a household size of between 4 - 6 persons and 23.3% having household size of between 10-12 persons. Figure 5 revealed that 58% had one form of formal education. Education enhances individual farmer's ability to make correct decision on the adoption of technologies and practice in the farm. This is in consonance with Ayoade (2012) and Akintonde *et al.* (2016) who reported the range of household size was between 5-10 persons. Figure 6 show that the mean years of farming experience was about 23years which indicates that they have been involved in agricultural activities for a relatively long time and should be familiar with climatic condition prevalent in their area and are likely accept and adapt any strategy that will help to mitigate the effect of climate change on crop production in the area. This is in agreement with Defeng *et al.* (2017) and Ifeanyi-obi *et al.* (2013) who reported that farming experience was above 20 years. Moreso, figure 7 revealed that 45.8% of the respondents had farm sizes of less than 2 hectares in scattered plots and in different locations. About 41.7% of the respondents had 2.1 to 4.0 hectares of farm land and only 12.5% had more than 4 hectares of farm land. With a mean farm size of 1.04ha, it implies that, majority of the respondents were basically small scale farmers. This corroborated the findings of Segun, *et al.* (2010) who found that most of the farmers had affirm size of less than 2 hectares. Also, figure 8 shows that 60.0% of respondents planted between 16 -25kg of rice seed with 27.5% planting between 26 -35kg, 10.8% planting above 36kg and 1.7% planting between 1 -15kg of rice seed.

### Determinants of climate adaptation strategies

Multinomial logit regression was used for the analysis (Table 2). The result revealed that income, years in school and years in farming were positively significant. The incomes of the respondents was positively significant and had positive effect on probability of changing crop variety and building water conservation scheme, and reduce number of livestock and diversity from farming to non-farming activity. The income of the respondents was positively significant and had positive effect on

probability of changing crop variety and building water conservation scheme, and reduce number of livestock and diversity from farming to non-farming activity. Higher level of education are positively related to adoption of improved technologies. Farmers with more schooling are expected to adapt better climate changes and extreme climatic events. The values from result indicate that higher educational level have positive effect in accepting seeking early warning information and changing planting date. This is in consonance with Nkanya *et al.* (2008) and Gbegeh and Akubinto (2012). The level of farming experience increases the possibility of undertaking different adaptation strategies, since experienced farmers are knowledgeable and better informed on climate change. Farm experience here is significant for two adaptation strategies: changing crop variety and build water conservation scheme, and implement soil conservation scheme and use of chemical fertilizer. This agrees with the findings of Gbegeh and Akinbinto (2012) and Nhemachena and Hassan (2007). Furthermore, the result show that farm size was positively significant with changing crop variety and build water conservation scheme. This implies that as farm size increases, adaptation of changing crop variety and build water conservation scheme will increase. Increase in farmland reflects the farmer positive attitude towards practicing rice farming and as such would welcome new adaptation strategies. Moreso, household size is negatively significant. It implies that as household size increase, the probability to adapt to new technologies decreases. An increase in household size will reduce the adaptation strategy of changing crop variety and build water conservation scheme. This can be attributed to extra household expenses in the house which can reduce the amount spent on farming practices.

Table 3 shows the marginal effects on determinants of various adaptation strategies. The results show that two variables (income from farm activities and years in farming) were positively significant and had positive marginal effect on probability of choosing and using various adaptation strategies while household size was negatively significant. This implies that marginal increase in income from farm activities and years in farming would cause a 1.97E-07 and 0.0161 increase in probability of choosing and using cultivation of improved varieties. Furthermore, marginal increase in household size will lead to a decrease in the probability of choosing cultivation of improved varieties, Change in planting date, fertilizer application, Seeking early warning information and use of conservation practices 0.0547.

### CONCLUSION AND RECOMMENDATIONS

The study examined the climate adaptation measures by IFAD-VCDP rice farmers in Wushishi LGA, Niger state. The study concluded that climate change had negative effect on the farmers income which resulted in adapting to various adaptation strategies to improve the income. The farmers made use of various adaptation strategies that helped in adjusting to climate change in the study area. The marginal increase in income from farm activities and years in farming would cause an increase in probability of choosing and using cultivation of improved varieties. It is therefore recommended that the farmer should continue to adapt more climate adaptation strategies in order to improve their income. Such strategies are the use of information system, improved varieties and use of resources in efficient manner in order to obtain high yields and hence more income.

**Table 1: Sample frame and size of registered Rice farmers under Wushishi local government area, Niger state**

VILLAGES	SAMPLE FRAME	SAMPLE SIZE
Danko	36	25
Kanko	47	33
Wushishi	30	21
Bankwagi	60	41
<b>TOTAL</b>	<b>173</b>	<b>120</b>

**Source:** Federal Ministry of Agriculture and Rural Development, (2017).

**Table 2: Distribution of respondents according to climate adaptation strategies**

Adaptation strategies	CCVABWCS	ISCSAUOCF	SEWIACPD	RNOLADFFTNA
-----------------------	----------	-----------	----------	-------------

Constant	-3.166 (-1.44)	-3.755 (-1.46)	-5.235 (-2.58)	-3.528 (-1.48)
Income from farming activities	2.57E-06 (1.75)*	2.20E-06 (-1.38)	-1.42E-07 (-0.09)	3.38E-06 (2.34)**
Age	-0.086 (-1.32)	-0.071 (-0.95)	-0.044 (-0.84)	-0.0456 (-0.69)
Household size	-0.44 (-1.94)*	-0.175 (-0.68)	0.131 (-0.75)	-0.057 (-0.26)
Source of capital	-0.21 (-0.16)	-0.591 (-0.37)	-0.816 (-1.83)*	-0.614 (-0.56)
Years in school	0.092 (-0.73)	0.114 (-0.79)	0.178 (1.92)*	0.055 (-0.52)
Years in farming	0.272 (3.04)***	0.228 (2.27)**	0.212 (2.81)***	0.168 (1.84)*
Farm size	0.657 (1.66)*	0.411 (-0.91)	0.43 (-1.39)	0.158 (-0.39)
Access to credit	-10.507 (-0.01)	-11.750 (-0.01)	0.501 (-0.33)	1.377 (-0.87)
Off farm income	3.21E-06 (-1.60)	2.08E-06 (-0.88)	2.72E-06 (-1.51)	3.36E-06 (-1.62)

Number of observations =

120

Source: Computer data, 2018

**NOTE:** CCVABWCS stands for Change crop variety and Build water conservation scheme, ISCSAUOCF stands for Implement soil conservation scheme and use of chemical fertilizer, SEWIACPD stands for Seeking early warning information and changing planting date, RNOLADFFTNA stands for Reduce number of livestock and diversity from farming to non-farming activity

Figures in parentheses are Z- values

\*\*\* denotes 1%, \*\* denotes 5%, while \* denotes 10% level of significance.

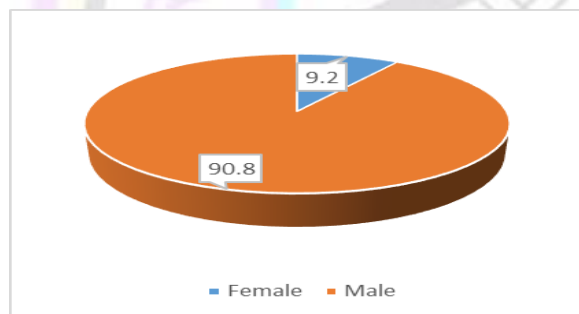


Figure 1: Sex of respondents

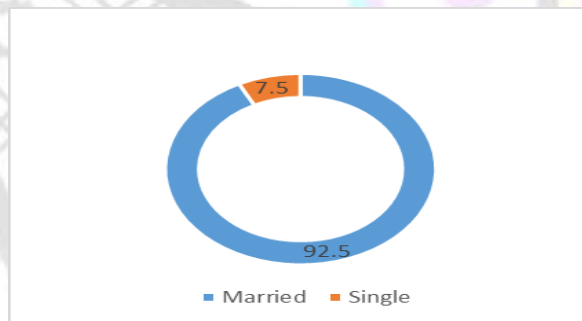


Figure 2: Marital status of respondents

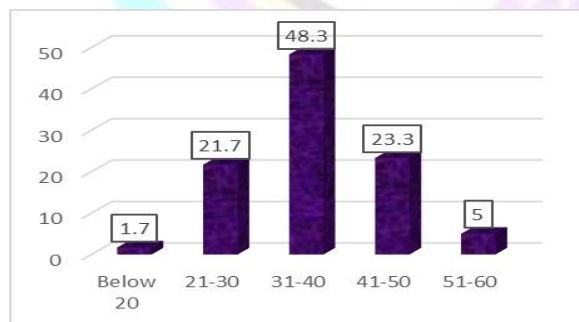


Figure 3: Age of respondents

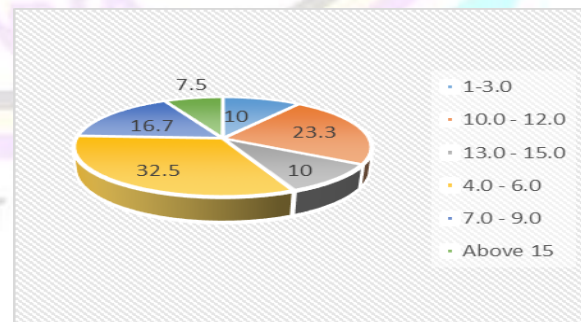


Figure 4: Household size of respondents



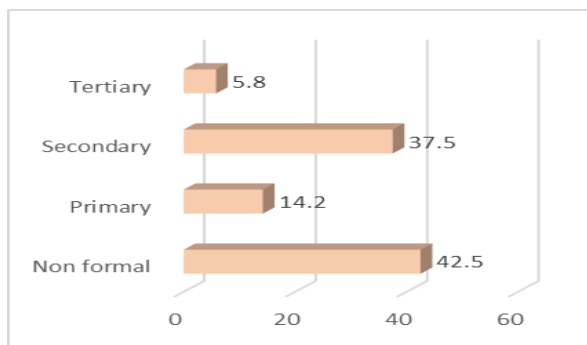


Figure 5: educational status of respondents

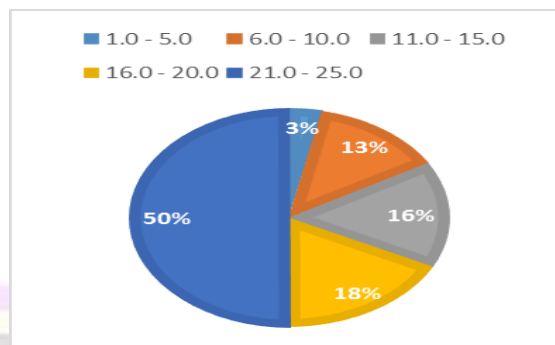


Figure 6: farm experience of respondents

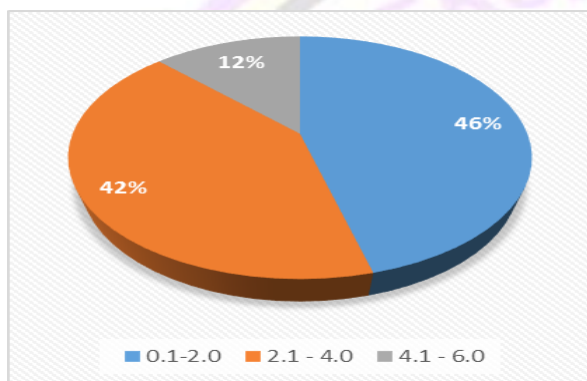


Figure 7: farm size of respondents

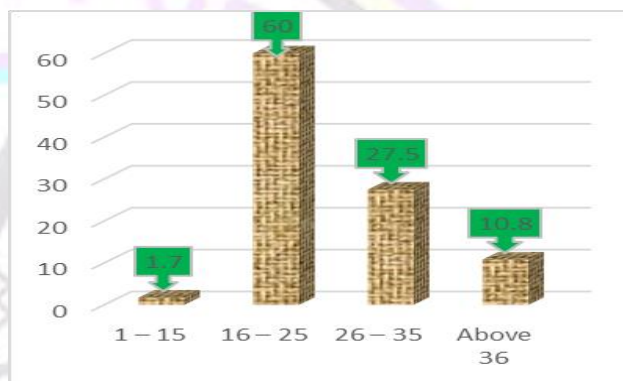


Figure 8: amount of seed planted / hectare

## REFERENCES

- Akinbode, S. O. (2013). Access to credit: Implication for sustainable rice production in Nigeria. *Journal of Sustainable Development in Africa*. 15 (1), 13-30.
- Akintonde J. O., Shuaib L (2016) Assesment of Level of Use of Climate Change Adaptation Strategies among Arable Crop Farmers Oyo and Ekiti States, Nigeria. *Journal Earth Science Climate Change* (7), 369.
- Arimi, K. (2014). Determinants of climate change adaptation strategies used by rice farmers in South-Western Nigeria. *Journal of Agriculture and Rural Development in the Tropics and Subtropics*. 115(2):91-99.
- Ayoade, A.R. (2012). Determinants of Climate Change on Cassava Production in Oyo State, Nigeria. *Global Journal of Science Frontier Research Agriculture & Biology*. 12 (3):45-49
- Defang, T. J., Amungwa, F.A. & Manu .I (2017). Farmers' Perception of Climate Change and

Adaptation Options in Southwest Cameroon. *International journal of Rural Development, Environment and Health Research (IJREH)*. 1(3), 102- 114

Edeh, H.O, Eboh, E.C., Mbam, P.N. (2011). Analysis of environmental risk factors affecting rice farming in Ebonyi state, Southeastern Nigeria. *World Journal of Agricultural Science*. 7(1):100-103

Eisenack, K. & Stecker, R. (2010). An Action Theory of Adaptation to Climate Change. Paper presented at the 2010 Berlin Conference on the Human Dimensions on Global Environmental Change.

Ifeanyi-Obi, C. C., Etuk, U. R. & Jike-Wai, O. (2012). Climate change, effects and adaptation strategies: implication for agricultural extension system in Nigeria. *Greener Journal of Agricultural Science* 2(2):053-060.

Ikehi, M.E., Zimoghen, J. (2015). Impacts of climate change on fishing and fish farming in Niger Delta Region of Nigeria. *Direct Resource Journal of Agricultural Food Science*. 3(1):1-6.

International Food Policy Research Institute (IFPRI), (2008). An Agricultural Policy, Research and Knowledge Program to support Nigeria's National Economic Empowerment and Development Strategy (NEEDS)". Accessed from

<http://www.ifpri.org/publication/poverty-and-nutrition-policy-analysis>

International Institute of Tropical Agriculture and Consultative Groups on International Agricultural Research (IRRI), (2000); Annual Report, Impact publishing Nigeria Limited Ibadan. Pp 164-16

Manneh, B., Kiepe, P., Sie, M., Drame, N. K. & Traore, K. (2007). Exploiting partnerships in research and development to help African rice farmers cope with climate variability. *The Journal of Semi-Arid Tropical Agricultural Research (International Crops Research Institute for the Semi-Arid Tropics (ICRISAT)*. 4(1):2-6

National Population Commission of Nigeria (NPC), (2006). Population Distribution by Age and Sex; 2006 Census Priority Tables (Volume 4). Accessed from <http://www.population.gov.ng/index.php/publications/141> population-distribution

Nguyen, V.N. (2004). FAO programme on hybrid rice development and use for food security and livelihood improvement. Paper presented at the concluding workshop of the IRRI- ADB funded project. 'Sustaining food security in Asia through the development of hybrid rice technology'. IRRI, Los Banos, Philippines, 7-9 Dec

Quan, J. & Dyer, N. (2008). Climate change and land tenure: The implications of climate change for land tenure and land policy. Land Tenure Working Paper 2, FAO, Rome. P. 21.

United Nations Framework Convention on Climate Change (UNFCCC) (2007). Report on the workshop on climate related risks and extreme events. Note by the secretariat. FCCC/SBSTA/2007/7. UNFCCC. Bonn, Germany. 15 pp.

United Nations Population Fund (UNFPA), (2016). UNFPA in Niger State: population projections. Accessed from [www.unfpa.org/niger.html.10/07/2015](http://www.unfpa.org/niger.html.10/07/2015).

[www.nigerstate.gov.ng](http://www.nigerstate.gov.ng)

Yamane, M. (1979). *Journal of Materials Science*. 14: 607-611. Accessed from <https://doi.org/10.1007/BF00772720>

# SOCIOECONOMIC DETERMINANTS OF ADOPTION LEVELS OF ADAPTIVE YAM MINISETT TECHNOLOGY BY FARMERS IN FEDERAL CAPITAL TERRITORY, NIGERIA

Otene<sup>1\*</sup>, N. U., J. H. Tsado<sup>1</sup>, I. T. Salihu<sup>1</sup>

<sup>1</sup> Department of Agricultural Extension and Rural Development, Federal University of Technology, Minna, Niger State, Nigeria

\*Corresponding Author's E-mail: [nathotene@gmail.com](mailto:nathotene@gmail.com), GSM: 07039626149

## ABSTRACT

This study examined the socioeconomic determinants of adoption levels of adaptive yam minisett technology by farmers in Federal Capital Territory, Nigeria. Multi-stage and simple random sampling techniques were employed to select 153 farmers from 3 Area Councils who adopted adaptive yam minisett technology and. Primary data used for this study were collected using a structured questionnaire. Research findings revealed more male farmers (76%), and the mean age of the respondents was 39.2 years. About 80% of the respondents had formal education, with an average of 23.2 years of farming experience. Average yam farm size and mean annual household income were 0.77ha and ₦77,418.30 respectively. Mean household size was about 8 persons, and 62.7% of the respondents were members of cooperative societies. Majority (51.6%) of the respondents were medium adopters, adopting between 4 and 6 packages of the technology. The ordered logistic regression analysis results confirmed level of education ( $Z=3.21$ ), yam farm size ( $Z=-3.71$ ), annual household income ( $Z=2.45$ ) and membership of cooperative societies ( $Z=2.59$ ) to significantly affect the adoption levels of the technology. This study therefore recommended strengthening of agricultural extension services to encourage higher adoption of yam minisett technology, while financial support is provided to the farmers as their income had a positive impact on their level of adoption of the technology.

**KEYWORDS:** Determinants, adoption levels, adaptive yam minisett technology

## INTRODUCTION

Yam is a tuber crop belonging to the family Dioscoreaceae. The species of economic importance include *Dioscorea rotundata*, *Dioscorea alata*, *Dioscorea cayenensis*, *Dioscorea dumetorum*, *Dioscorea bulbifera* and *Dioscorea esculenta* (Bassey, 2017). In West Africa, *D. rotundata*, also referred to as white yam or white guinea yam, is the most widely cultivated. Nigeria produced about 38 million tonnes of yam in 2012, approximately 65% of the world's total yam production thus being the largest producer of yam in the world (FAO, 2014). According to FAO (2014), after cassava, yam had the second highest production level of all food crops in Nigeria. Apart from the important role yam plays by providing cash and dietary carbohydrate, it is also used in many parts of West Africa for social and religious festivals such as traditional marriage ceremonies, as well as in sacrificial ceremonies of traditional religions (Izekor and Olumese, 2010).

In Nigeria, the traditional methods of obtaining planting materials, referred to as seed yam are from farmer-saved seeds from previous year's harvest, double harvesting or milking and cutting of large ware tubers of up to 2 kg into seed sized setts of 300-

500 g, a process referred to as 'junking' which reduces substantially the quantity of tubers that could be used for food (Nahanga and Vera, 2015). Seed yams derived from the traditional methods have a low multiplication ratio within 1:5 and 1:10. And farmers who buy seed yam from the market for planting are likely to increase their overall production cost by 50% (Aighewi *et al.*, 2014).

The constraints associated with getting quality seed yams led to the introduction of Yam Minisett Technology (YMT) by the National Root Crop Research Institute, Umudike in collaboration with International Institute of Tropical Agriculture (IITA), Ibadan Nigeria in the late 1970s to rapidly multiply yam germplasm and address the frequent problems of high cost and non-availability of seed yam (Oguntade *et al.*, 2010). The YMT involves cutting 'mother' yam tubers into smaller sett sizes of between 25-100g. The treated setts are treated with chemicals to prevent pests and diseases and then planted to produce small whole seed tubers. Though the initial size of setts introduced was about 25g and required pre-sprouting in a nursery, Aighewi *et al.* (2014) reported a positive correlation between minisett sizes



and seed yam they produce, thus minisetts sizes have been varied over the years to even 100g.

According to Lawal *et al.* (2014), the adoption rate of the YMT has been low despite decades of its introduction. In the early 2000s, modification of the YMT gave rise to the term Adaptive Yam Miniset Technology (AYMT) which introduced larger sett sizes of between 40-120g to be used for seed yam production, which can be planted directly on the field after rains have been established without pre-sprouting in nursery (McNamara *et al.*, 2012; Morse and McNamara, 2014). Also, the pesticide dust used for minisetts treatment in YMT which stays on the surface of minisetts was replaced with a pesticide dip containing a mixture of insecticide and fungicide which allows for deeper penetration of chemicals into the flesh of the minisetts was recommended. All of these modifications were intended to make the technology more farmer friendly.

The introduction of the Yam Improvement for Income and Food Security in West Africa (YIIFSWA) Project from 2011 to 2015 popularized the use of AYMT in the Federal Capital Territory. According to Lopez-montes *et al.* (2012), the rate of increase in yam production in West Africa has been slowing due to deteriorating soil fertility and poor quality of seed yams. It was predicted that yam production could decrease dramatically over the next fifteen years unless urgent steps are taken to reverse the decline and the AYMT remains a better alternative to the production of high quality seed yams for planting at a higher multiplication ratio of up to 1:30, depending on the minisetts size used, compared to the traditional methods of obtaining seed yams.

Literatures are replete on adoption studies that have established significant relationships among farmers' socioeconomic characteristics and the overall adoption of the YMT (Ajie, 2012; Ayoola, 2012). Significant farmers' socio-economic characteristics found to influence the economics of yam miniset production include age, gender, educational status, membership of societies and household size (Ibitoye and Onimisi, 2013; Gbegeh and Akubuilu, 2012). These socio-economic attributes refer to the personal predisposing factors of the farmer who makes decisions on whether to adopt or reject a given technology (Tey and Brindal, 2012). This study thus seeks to find out the socioeconomic characteristics of yam farmers who adopted AYMT in the FCT, to categorize farmers based on adoption levels of AYMT packages and to determine the socioeconomic characteristics that influence adoption levels of AYMT.

## METHODOLOGY

### Study Area

The study was conducted in the Federal Capital Territory (FCT), Abuja. FCT was established by decree No. 6 of 1976 and is in the geographical center of the country, bounded by Kaduna, Kwara, Kogi, Nasarawa, Niger and Plateau States. It lies between longitudes 6°45' and 7°45' East, latitudes 8°25' and 9°25' North (Dawan, 2000). It has a landmass of 7,607 square kilometers and an estimated population of 1,406,239 which was projected to be 3,628,696 in 2017 at 9% population growth rate based on National Population Census Figure of 2006 (Nigerian Bureau of Statistics, 2012). FCT comprises of six area councils namely: Abaji, Bwari, Gwagwalada, Kuje, Kwali and Abuja Municipal Area Councils. FCT falls within the Savannah Zone vegetation of the West Africa sub-region, experiencing two distinct seasons annually, the rainy and dry seasons. In between the two, there is a brief interlude of harmattan occasioned by the northeast trade wind, with the main feature of dust haze and dryness (Adakayi, 2000). The rainy season begins from April and ends in October with an annual rainfall of between 1174.7mm and 1471.8mm while the dry season, characterized by coldness and dryness, begins in November and ends in March. It records a mean annual temperature ranging from 22°C to 37.1°C (NBS, 2012). The major crops grown in the area include yam, cowpea, maize, rice, cassava and sorghum.

### Sampling Technique and Sample Size

Multi-stage and simple random sampling techniques were used for this study. All the yam farmers who adopted AYMT in the Federal Capital Territory constituted the population for the study. The first stage of sampling involved a random sampling of three Area Councils: Kwali, Gwagwalada and Bwari from the existing six Area Councils in the FCT. In the second stage, two communities were randomly selected from each Area Council to make a total of six communities. In the third and final stage, a sample size of 153 respondents was randomly selected from a population of 252 adopters of AYMT using the Taro Yamane formula, computed as:

$$n = \frac{N}{1 + N(e)^2}$$

Where:

n = sample size

N = finite population

1 = unity

e = level of significance

### Analytical Technique

The data for the study were analyzed using both descriptive and inferential statistics. Descriptive statistics such as frequency distribution, percentages and mean were used to describe the socioeconomic characteristics of yam farmers who adopted AYMT, and categorization of adopters into low, medium and high based on the number of AYMT packages adopted was done using Likert-type scale. Ordered logistic regression was used to determine the socioeconomic factors influencing adoption levels of AYMT.

AYMT Packages measured were:

- i. Selection of healthy sprouted yam tubers for minisett
- ii. Cutting of selected tubers in to 40 – 120g minisett sizes
- iii. Treatment of minisett with insecticide and fungicide mixture
- iv. Drying treated minisett under a shade for about 12-24 hours
- v. Planting minisett on ridges
- vi. Plant spacing of 100cm x 50cm inter-row and intra-row
- vii. Plant depth of 10cm
- viii. Planting after rain has been established
- ix. Staking of growing yam plants with 1-2m stakes

Adopters were categorized as low if 1-3 packages were adopted, medium if 4-6 packages were adopted and high if 7-9 packages were adopted.

### Model specification and estimation

The ordered logistic regression analysis is specified as:

$$Y=f(X_1, X_2, X_3, X_4, X_5, X_6, X_7, X_8)$$

Where:

Y = Adoption levels of AYMT packages (1-3 packages =1, 4-6 packages =2, 7-9 packages = 3)

X<sub>1</sub> = Sex (1 if male, 0 otherwise)

X<sub>2</sub> = Age (years)

X<sub>3</sub> = Educational level (years)

X<sub>4</sub> = Farming experience (years)

X<sub>5</sub> = Farm size (hectares)

X<sub>6</sub> = Household income (naira)

X<sub>7</sub> = Household size (persons)

X<sub>8</sub> = Membership of cooperative societies (yes=1, no=0)

## RESULTS AND DISCUSSION

### Socioeconomic characteristics of Adaptive Yam Minisett Technology Adopters

The result of the socioeconomic characteristics of AYMT adopters is presented in Table 1. It was found that 76% of the respondents were male while 24% were female. A finding which agrees with Okoro & Ajieh (2015) and Ajieh (2012), who revealed that there were more male yam farmers compared to female yam farmers in their studies on Yam Minisett Technology. The mean age was 39.2 years, implying that majority of adopters were in their most active and productive years. Majority of the sampled farmers (36.6%) had completed secondary education. On the average, adopters have been involved in yam farming for 23.2 years on an average yam farm size of 0.77 hectares. The mean annual household income was ₦477, 418.30. The average household size was about 8 persons living under the same roof and eating from a common source. About 63% of the sampled farmers belonged to at least one cooperative society.

### Categorization of Adoption levels based on the number of AYMT packages adopted by farmers

From the result presented in Table 2, majority (51.6%) were medium adopters, adopting between 4-6 technology packages. The least category of adopters were low adopters (17%), adopting between 1-3 technology packages while 31.4% were high adopters. This implies that AYMT is being adopted by majority of farmers in the FCT.

### Socioeconomic determinants of AYMT adoption levels

The result of the ordered logistic regression, presented in table 3 revealed a Pseudo R<sup>2</sup> of 0.1851, indicating that the independent variables accounted for 18.51% of variations in levels of AYMT adoption. The Chi<sup>2</sup> (0.0000) was found to be significant at 1% level of probability and shows the fitness of the model. The levels of education (Z= 3.21) had a significant and positive relationship with level of adoption at 1% probability level, indicating that respondents with higher levels of education have a higher probability to adopt AYMT. This could be because of their higher exposure and more consciousness to increase their production levels. This finding is similar to that of Lawal *et al.* (2014), who reported that highest level of education and membership of cooperative societies were statistically significant at influencing farmers' likelihood of adopting yam minisett technology.

The farm size of the respondents was statistically significant (Z = -3.71) at 5% alpha level and had a negative coefficient, implying that farmers with large farms have a lower probability to adopt AYMT. This could be because of the high cost involved in practicing the minisett technology to cover their large

farms. The advantage of AYMT is to increase good quality seed yam and invariably larger farm sizes therefore farmers with already large farms will adopt less packages.

Annual household income ( $Z = 2.45$ ) and membership of cooperative societies ( $Z = 2.59$ ) had a significant positive relationship with levels of adoption of AYMT at 5% and 1% probability levels respectively. Anozie *et al.* (2014) also found income of farmers to affect their level of adoption of technologies. Gender, age, years of yam farming and household size had no significant effect on level of AYMT adoption.

### **CONCLUSION AND RECOMMENDATIONS**

This study concluded that Adaptive Yam Miniset Technology was being adopted by more male yam farmers than females, 62.7% of adopters were members of cooperative societies and the majority of farmers who adopted AYMT were medium adopters, adopting between 4-6 packages out of the 9 technology packages identified. Level of education, yam farm size, annual household income and membership of cooperative societies were statistically significant determinants of adoption levels of AYMT. The study therefore recommended strengthening of agricultural extension services to enhance the level of adoption of AYMT, and provision of financial assistance to the farmers to increase their level of adoption of AYMT.



Table 1: Socioeconomic characteristics of adopters of AYMT (n=153)

Variable	Frequency	Percentage	Mean
<b>Sex</b>			
Female	36	24	
Male	117	76	
<b>Age</b>			
Below 35 years	46	30.0	
35-44 years	59	38.6	39.2
45-54 years	30	19.6	
Above 54 years	18	11.8	
<b>Educational level</b>			
No formal education	32	20.9	
Primary	42	27.5	
Secondary	56	36.6	
Tertiary	23	15.0	
<b>Years of yam farming experience</b>			
Below 15 years	41	26.8	
15-24 years	49	32.0	
25-34 years	35	22.9	23.2
35-44 years	18	11.8	
Above 44 years	10	6.5	
<b>Yam farm size (ha)</b>			
0.01-1.00	105	68.6	
1.01-2.00	39	25.5	0.77
2.01-3.00	6	3.9	
> 3.00 ha	3	2.0	
<b>Annual household income</b>			
< ₦ 150,000	4	2.6	
₦ 150,000-N 299,000	30	19.6	
₦ 300,000-N 449,000	52	34.0	
₦ 450,000-N599,000	26	17.0	477,418.30
₦ 600,000-N749,000	19	12.4	
> ₦ 749,000	22	14.4	
<b>Household size</b>			
<5	34	22.2	
5-10	88	57.5	
11-16	24	15.7	≈8.0
>16	7	4.6	
<b>Membership of cooperative Society</b>			
None	57	37.3	
Yes	96	62.7	

Source: Field Survey, 2018

Table 2: Categorization of adoption levels based on the number of AYMT packages adopted by farmers

Adopter categories	Frequency	Percentage
Low adopters (1-3 technology packages)	26	17.0
Medium adopters (4-6 technology packages)	79	51.6
High adopters (7-9 technology packages)	48	31.4
<b>Total</b>	153	100.0

Source: Field Survey, 2018

Table 3: Socioeconomic determinants of AYMT adoption levels

Variables	Coefficient	Std. Err.	Z statistics	Probability Z
Gender	.2400968	.5012472	0.48	0.632
Age	.0395461	.0553614	0.71	0.475
Level of education	.7439607	.232012	3.21***	0.001
Years of yam farming	.0125977	.0555905	0.23	0.821
Farm size	-1.60601	.4333883	-3.71***	0.000
Annual Household income	3.21e-06	1.31e-06	2.45**	0.014
Household size	.0920804	.0628944	1.46	0.143
Membership of cooperative	1.100809	.4258339	2.59***	0.010

Number of observations = 153

LR Chi<sup>2</sup> = 56.99

Pseudo R<sup>2</sup> = 0.1851

Probability Chi<sup>2</sup> = 0.0000

Note: \*\*\*, \*\* implies significance at 1% and 5% levels of probability.

Source: Data Analysis, 2018

## REFERENCES

- Adakayi, P. E. (2000). Climate. In Dawan, P. D. (ed.). *Geography of Abuja Federal Capital Territory*. Famous/Asanlu Publishers, Minna, Niger State, Nigeria, pp. 9-23.
- Aighewi, B. A., Maroya, N. G., & Asiedu, R. (2014). *Seed yam production from minisetts: A training manual*. Ibadan, IITA, Nigeria.
- Ajieh, P. C. (2012). Adoption of yam (*Dioscorea* spp.) miniset technology in Delta State, Nigeria. *Agricultura Tropica et Subtropica*, 45(2), 84-88.
- Anozie, R. O., Anozie, S. N., Usanga, U. J., & Okelola, O. E. (2014). The state of adoption of yam miniset technique in Imo state, Nigeria. *Asian Journal of Agricultural Extension, Economics & Sociology*, 3(6), 562-568.
- Ayoola, J.B. (2012). Socio-economic determinants of the adoption of yam miniset technology in the middle belt region of Nigeria. *Journal of Agricultural Science*, 4(6), 215-222.
- Bassey, E. E. (2017). Constraints and prospects of yam production in Nigeria. *European Journal of Physical and Agricultural Sciences*, 5(1), 55-64
- Food and Agriculture Organization (FAO). (2014). Retrieved 08 01, 2014, from <http://faostat3.fao.org/faostat-gateway/go/to/download/Q/QC/E>
- Gbegeh, B. D., & Akubuilu, C.J.C. (2012). Socioeconomic determinants of adoption of yam miniset by farmers in Rivers state, Nigeria. *Wudpecker Journal of Agricultural Research*, 2(1), 33 - 38.
- Ibitoye, S. J., & Onimisi J. A. (2013). Economic assessment of yam production in Kabba-Bunu Local Government Area of Kogi State, Nigeria. *Journal of Development and Agricultural Economics*, 5(11), 470-475.
- Izekor, O. B., & Olumese, M. I. (2010). Determinants of yam production and profitability in Edo State, Nigeria. *African Journal of General Agriculture*, 6(4), 30-35.
- Lawal, A. F., Liman, A., & Lakpene, T. (2014). Adoption of yam miniset technology by

- farmers in Niger State, Southern Guinea Savannah, Nigeria. *Nigerian Journal of Agriculture, Food and Environment*, 10(1), 65-71.
- Lopez-Montes, A., Asiedu, R., Jemo, M., Hauser, S., Bhattacharjee, R., & Matsumoto, R. (2012). Increasing Productivity and Utilization of Food Yams in Africa (IPUFYA). *Paper presented at the 16th Triennial Symposium International Society for Tropical Root Crops, 23rd - 28th Sept.* Federal University of Agriculture, Abeokuta, Nigeria.
- McNamara, N., Morse, S., Ugbe, U. P., & Claudius-Cole, A. (2012). Facilitating healthy seed yam entrepreneurship in the Niger River system in Nigeria: the value of 'Research Into Use'. *Outlook on Agriculture*, 41(4), 257-263.
- Morse, S., & McNamara, N. (2014). The adapted yam minisett technique for producing clean seed yams (*Dioscorea rotundata*): Agronomic performance and varietal differences under farmer-managed conditions in Nigeria. *Experimental Agriculture*, doi: 10.1017/S0014479714000428. Retrieved from <http://www.researchgate.net/publication/277924052>.
- Nahanga, V. and Vera, B. (2015). An analysis of yam production in Nigeria. Retrieved from <http://dx.doi.org/10.11118/actaun201563020659>
- NBS, (2012). Annual abstract of statistics, National Bureau of Statistics, Nigeria.
- Oguntade, A. E., Thompson, O. A., & Ige, T. (2010). Economics of Seed Yam Production using minisett techniques in Oyo State, Nigeria. *The Journal of field Actions*, 4, 1-10.
- Okoro, B.O., & Ajieh, P.C. (2015). Farmers' Perception and Adoption of Yam Minisett Technology in Anambra State, Nigeria. *Agriculture Science and Practice*, 3, 95-96.
- Tey, Y.S., & Brindal, M. (2012). Factors influencing the adoption of precision agricultural technologies: a review for policy implications. *Precis Agric*, 13, 713-730.



## LIVELIHOOD DIVERSIFICATION AND INCOME INEQUALITY AMONG HOUSEHOLDS IN MINNA METROPOLIS NIGER STATE

\*Ogaji, A., Adewumi, A., Ibrahim, M. and Ocheja, F. A.

Department of Agricultural Economics and Farm Management, Federal University of Technology, P. M. B. 65, Minna, Niger State, Nigeria.

\*Corresponding author: [abuogaji@yahoo.co.uk](mailto:abuogaji@yahoo.co.uk) +2348062125740

### ABSTRACT

*The study examined the livelihood diversification and income inequality of households in Minna, Niger state. Multistage sampling technique was employed to select a total of 120 respondents. Data were collected with the aid of a structured questionnaire and were analyzed using descriptive statistics, Gini coefficient, Simpson's Index of Diversity and Tobit regression model. The result of the research indicated that the respondents were into both off-farm and on-farm activities and trading, livestock and crop farming were the major livelihood activities of the respondents. Result of Gini coefficient indicated that there is income inequality (0.795) among the respondents while the Simpson's index of diversity (SID) showed a high level of diversity in the area (0.76). The need for the respondents to get involved in both agricultural and non-agricultural activities in order to diversify income sources and earn more income was recommended.*

**KEYWORDS:** *livelihood, diversification, income inequality and household.*

### INTRODUCTION

Livelihood diversification refers to attempts by individuals to raise income and reduce poverty (Hussein and Nelson, 1999). For rural households, it includes both on and off-farm activities which are under taken to generate additional income. In Africa, different studies have demonstrated that while most provincial family units are involved in farming activities, for example, livestock production, crop production and fish farming as their primary wellspring of livelihood, they additionally participate in other income producing ventures. A lion's share of provincial family has truly expanded their beneficial activities to envelope a scope of other profitable businesses.

Rising income inequality threatens growth and poverty reduction targets. This was why the united nation millennium summit put it as one of its main targets, and it was endorsed by virtually all world leaders to reduce the incidence of income inequality in developing countries from 30% to 15% between 1990 to

2015 (Adejuwon and Tijani, 2012). In Niger state, families that are poor are those that live below \$1 per day as well as individuals who experience the ill effects of tremendous imbalances in incomes, wellbeing status, and instability (National Bureau of Statistics, 2013). Oyekale *et al.* (2004) reported that the general Gini coefficient for Nigeria was 0.580. The study also discovered income inequality to be higher in provincial territories in contrast with urban regions and that business income expands income inequality. Nigerian profile report of 2010 showed that while income inequality rose from 0.429 in 2004 to 0.447 in 2010, destitution occurrences were 28.1, 46.3, 65.6, 58.3 and 69% in 1980, 1985, 1996, 2005 and 2010 respectively (world Bank, 1996; IMF, 2005 and NBS, 2010). Income inequality has become a significant open strategy challenge among improvement organizations and destitution diminishing specialists.

Various studies such as those of Ellis (2000) and Oyekale *et al.* (2004) have demonstrated that rustic families in the sub-Saharan Africa get their income from different sources with non-agrarian exercise representing a significant offer of aggregate income. Correspondingly, the general conviction that income inequality is nearly identified with destitution and that inequality is more broad and predominant in provincial than urban zones (IPAD 2001 and Oyekale *et al.*, 2004) supports the behavior of a top to bottom examination of rustic income inequality.

It has been build that neediness is common in Nigeria with the higher rate of the poor followed by the rustic cultivating family units, and income inequalities has been to a great extent connected with destitution (McKay, 2002). That is the reason neediness and income inequalities destitution are the first among the eight thousands years advancement objectives (Adejuwon and Tijani, 2012).

#### METHODOLOGY

The study was conducted in Minna Niger state. The state is located in the North Central part of Nigeria and it lies between Longitudes 3°30'E to 7°20'E and Latitudes 8°20'N to 11°30'N. The state currently covers a total land mass of 76,000 square kilometers which is about 9% of the total land mass of Nigeria (Niger State Geographic Information System, 2007). The state also has a population of about 4 million people (National Population Commission, 2006) and a projected value of 4,702,376 at the end of 2013 (CBN 2.38% annual projection).

The study applied a multistage sampling technique in selecting the representative households used. The first stage was a purposive selection four wards from the two local government areas in Minna metropolis. In the second stage, two communities each were selected at random from the wards and the third stage involved the selection of 15 households each from the communities

systematically giving the total sample size of 120 households.

The primary data collection involved the use of a structured questionnaire administered to the respondents. Data on socioeconomic and demographic characteristics as well as in other indicators of livelihood diversification activities of the respondents were obtained.

The data collected were analyzed using descriptive statistics, Gini coefficient, Simpson's Index of Diversity (SID) and Tobit regression model.

#### Model specification

##### The Gini coefficient:

The Gini coefficient was used to determine the income inequalities among the respondents. It is specified as:

$$G = 1 - \sum xy$$

Where;

x = proportion of income, and

y = proportions of total income in categories

##### The Simpson's Index of Diversity (SID):

The Simpson's index of diversity was used to determine the livelihood diversification among the respondents. The formula is specified as:

$$SID = 1 - \sum pi^2$$

$$Pi = \frac{\text{income from } i^{\text{th}} \text{ source of livelihood}}{\text{total income from all sources}}$$

1 = constant

##### Tobit Regression model;

The tobit regression model was used to determine the influence of livelihood diversification on income inequality among the respondents. The implicit form of the model is expressed as:

$$Y = f \{X_1, X_2, X_3, X_4, X_5, X_6, X_7, X_8, \dots, X_{14}\}$$

The explicit form of the model is specified as:

$$Y = \beta_0 + \beta_1 X_1 + \beta_2 X_2 + \beta_3 X_3 + \beta_4 X_4 + \beta_5 X_5 + \dots + \beta_{14} X_{14} + \mu$$

Where;

Y = diversification index (individual Simpson's index)

X<sub>1</sub> = gender (male = 1, otherwise = 0)

X<sub>2</sub> = age (years)



- X<sub>3</sub> = education (years)  
 X<sub>4</sub> = marital status (married = 1; otherwise = 0)  
 X<sub>5</sub> = monthly income of respondents, (₦)  
 X<sub>6</sub> = household size (number)  
 X<sub>7</sub> = primary occupation (farming = 1, otherwise = 0)  
 X<sub>8</sub> = primary occupation (civil service = 1, otherwise = 0)  
 X<sub>9</sub> = primary occupation (artisan = 1, otherwise = 0)  
 X<sub>10</sub> = ownership house(s) (owner = 1, otherwise = 0)  
 X<sub>11</sub> = ownership of land (owner = 1, otherwise = 0)  
 X<sub>12</sub> = income from primary occupation (₦)  
 X<sub>13</sub> = returns from agriculture (₦)  
 X<sub>14</sub> = availability of non-farm opportunities (available = 1, otherwise = 0)

## RESULTS AND DISCUSSION

### Socio-economic characteristics of respondents

The result of the socioeconomic characteristics of the respondents is presented in Table 1. It showed that the mean age of the respondents was 41 meaning that majority of respondents are in their active age and could actively involved in various livelihood sources and earn more income. Majority of the respondents were males (70%) and were married (66.7%). An average of 6 members per household was observed and this had an impact on their reason for diversification. It was also observed that most of the respondents had one form of education or the other with the majority having tertiary education (57.5%). The mean income of respondents as presented in Table 2 was ₦218,247.67, using the national average of 6 persons per household; it means that per capita income in the area is ₦36,374.61; this is above national minimum wage operational in the country (Jude, 2013).

### Income distribution among the respondents

The result of the analysis on the extent of income inequality was presented in Table 3 and it shows that, income is unevenly distributed and is unequal, as a Gini ratio of 0.795 was obtained for the study area indicating that greater proportion of the respondents were in low income groups with about 28% earning income of 60,000 and below and a very high level of inequality in the income distribution. This is compared with Gini coefficients of 0.449 and 0.488 for southeast Nigeria and Nigeria in general respectively as reported by NBS (2005) and Aigbokhan (2008). This shows that Niger state has done well in addressing the income inequality among populace however, the gap between the rich and the poor is still very wide.

### Livelihood diversification among the respondents

On the livelihood strategies used by the respondents as presented in Table 4, 77 (64.3%) among them combined off-farm, on-farm and bank shares all together as livelihood sources.

The Simpson's index of diversity of the respondents in the study area as presented in Table 5 was 0.76 indicating that diversification was high as respondents adopted multiple income sources. Furthermore, with a large number of working age adults, it is likely that the household members are specialize individuals, who rear livestock, grow crops, engage in fish farming and at the same time are civil servants. (Minot 2006). However, so many reasons could bring about the diversification, which include the following in order of importance; large family size, limited income from the primary occupation, limited financial power and availability of off-farm opportunities as presented in Table 6.

### Determinants of livelihood diversification among the respondents

The result of the Tobit estimates of the determinants of livelihood diversification is



presented in Table 7. It shows that owing a land had a positive relationship with diversification, as respondents with land had more income sources. Availability of non-farm opportunities was also positively significant to diversification, as respondents move away from agriculture and ventured in to other fields, so was their income sources increasing and it implies that more income would be generated when respondents engaged in non-agricultural activities.

**Conclusion and recommendation**

Based on the findings of this study, it was concluded that, although the respondents were relatively diversified in their livelihood activities, there still exist income inequality among them. It is therefore, recommended that the respondents should get involved in both agricultural and non-agricultural activities in order to earn more income so as to improve on their standard of living.



**Table 1: Socio-economic characteristics of Respondents**

<b>Variables</b>	<b>Frequencies</b>	<b>Percentage (%)</b>
<b>Age</b>		
Less than 25	15	12.5
26-30	20	16.7
31-40	10	8.3
36-40	9	7.5
Above 40	66	55.0
Total	120	100
Mean	41.43	
<b>Gender</b>		
Male	90	75
Female	30	25
Total	120	100
<b>Household size</b>		
Less than 5	67	55.8
6+6-10	39	32.5
11-15	11	9.2
16-above	3	2.5
Total	120	100
Mean	5.71	
<b>Educational status</b>		
Primary	5	4.2
Secondary	34	28.3
Tertiary	69	37.5
None	12	10
Total	120	100

Source: Field survey, 2014

**Table 2: Income distribution of respondents in the study area**

<b>Income</b>	<b>Frequencies</b>	<b>Percentages (%)</b>
Less than 60,000	35	28.3
60,001-150,000	27	22.5
150,001-210,000	14	11.7
210,001-300,000	14	11.7
300,001 above	31	25.8
Total	120	100
Mean	218,247.67	

Source: Field survey, 2014

**Table 3: Gini coefficient of respondents**

Income	Frequencies	Proportion (X)	Total income	Proportion (Y)	$\Sigma Xy$
Less than 60,000	35	0.29	24,700,187	0.21	0.061
60,001-150,000	27	0.23	24,685,354	0.21	0.048
150,001-210,000	14	0.12	23,009,686	0.20	0.024
210,001-300,000	14	0.12	21,728,136	0.19	0.023
300,001 above	31	0.26	22,428,136	0.19	0.049
Total	120	1.02	116,551,498	1.00	0.205

Gini coefficient = 0.795

Source: Field survey, 2014

**Table 4: Livelihood strategies adopted by respondents**

Livelihood strategy	Frequencies	Percentage (%)
On-farm	23	19.2
Off-farm	16	13.3
Bank shares	4	3.3
All above	77	64.3
Total	120	100

Source: Field survey, 2014

**Table 5: Simpson's Index of Diversity of Respondents**

Income	Frequencies	Proportion ( $p_i$ )	Simpson's Index ( $\Sigma P_i$ )
Less than 60,000	35	0.3	0.09
60,001 – 150,000	27	0.2	0.04
150,001 – 210,000	14	0.1	0.01
210,001 – 300,000	14	0.1	0.01
300,001 above	31	0.3	0.09
Total	120	1	0.24

Simpsons index of diversity (1-D); =  $1 - 0.24 = 0.76$

**Table 6: Reasons for diversification**

Variables	Yes (%)	No (%)
Large family	36.7	63.3
Limited income from primary occupation	59.2	40.8
Limited returns from agriculture	42.5	57.5
Available off-farm opportunities	55.8	44.2
Limited financial power	72.5	27.5
Fun of it	33.3	66.7

Source: Field survey, 2014

**Table 7: Tobit estimates of the determinants of livelihood diversification**



<b>Variables</b>	<b>Coefficient</b>	<b>t-value</b>
Gender (male = 1, female = 0)	-0.00025	-0.01
Age (years)	-0.00023	-0.29
Marital status (married = 1, otherwise = 0)	0.01332	0.69
Income (₹)	6.67e-08	1.49
Household size (number)	-0.00430	-1.51
Primary occupation (farming = 1, otherwise = 0)	-0.01989	-0.82
Primary occupation (civil service = 1, otherwise = 0)	-0.02109	-0.92
Primary occupation (artisan = 1, otherwise = 0)	0.03799	1.05
Educational level (years)	0.01272	0.68
Ownership of house(s) (owner =1, otherwise = 0)	-0.00035	-0.02
Ownership of land (owner =1, otherwise = 0)	0.04957	2.06**
Large family	0.03486	1.40
Income from primary occupation (₹)	-0.03019	-1.23
Returns from agriculture (₹)	0.01388	1.61
Availability of non-farm opportunities (available = 1, otherwise = 0)	0.04080	2.12**
Constant	-0.01053	-0.31
Sigma	-0.01053	

Source: Field survey, 2014



## REFERENCES:

- Adejuwon, K. D. & Tijani, A. A. (2012). Poverty Reduction and the Attainment of the Millennium Development Goals in Nigeria: Problems and Prospects. *International Journal of Research in Social Sciences*, 2(2): 53-74
- Aigbokhan M.S. (1999) "the Impact of Adjustment Policies and Income Distribution In Nigeria: An Empirical Study Research Report", No. 5. Development Policy Center (Dpc), Ibadan, Nigeria.
- Hussein K., and Nelson J. (1999) Sustainable Lively hood and Lively Diversification. p3.
- National Bureau of Statistics (NBS), (2005). Poverty profile for Nigeria. A publication of National Bureau of Statistics, Abuja, Nigeria.
- National Bureau of Statistics (NBS), (2010). National Bureau of Statistics (NBS), (2013).
- Minot, N., Epprecht., M., Anh., T.T.T. And Trung, L.Q. (2006) Income Diversification in The Northern Uplands of Vietnam: *Research Report No. 145 international food policy research institute, Washington D.C.*
- Ellis F. (2000) rural lively hoods and diversity in developing countries. Oxford University Press, Oxford UK.
- Jude A. M. (2013). Analysis of Income Inequality and Poverty Dynamics Among Rural Farm Household In Abia State Nigeria. *International Journal of Food and Agricultural Economics*.
- Oyekale A.S., Adeoti A.I. and Ogunnupe T.O. (2004) *Sources of Income Inequality and Poverty in Rural and Urban Nigeria*. Nigeria: Department of Agricultural Economics, University of Ibadan

# CHARACTERIZATION AND SUITABILITY CLASSIFICATION OF SOME PLINTHIC LANDSCAPES FOR OIL PALM PRODUCTION IN NIGER STATE, NIGERIA

Lawal\*, B. A., A. I. Kolo, M. K. A. Adeboye, P. A., Tsado, A. Mohammed.

Department of Soil Science and Land Management, Federal University of Technology, PMB 65, Minna, Nigeria

\*Corresponding Author's email: [lawalba63@futminna.edu.ng](mailto:lawalba63@futminna.edu.ng) GSM: +2348036207353, +2347052838732

## ABSTRACT

A rapid reconnaissance survey was carried out to characterize and classify the suitability of some plinthic landscapes for cultivation oil palm (*Elaeis guinensis*) in Niger State, Nigeria. Two locations, Minna and Ijah-Gbagyi, were selected for the study. In each location, two representative profile pits were dug and described according to FAO guidelines for soil description. Soil samples were collected from genetic horizons for routine laboratory analysis. Suitability evaluation was performed using Square Root method. Results have shown that the color of the soils was dark brown (10YR3/3) which graded to dark yellowish brown (10YR4/4) in the subsoil in Minna, while Ijah-Gbagyi had dark yellowish brown (10YR3/4) overlaying various shades of light yellowish brown in the subsoil. Texture was sandy clay loam over gravely sandy clay in Minna; and gravely sandy loam over gravely sandy clay loam in Ijah-Gbagyi. Both locations had poorly drained substratum due to presence of indurated plinthic materials. Soil reaction was moderately acid (pH 5.9) in Minna to strongly acid (pH 5.3) in Ijah-Gbagyi. Organic carbon, CEC and percent base saturation were all medium to high. Actual suitability evaluation ranked both locations currently not suitable (N1) for oil palm due to limitation of rainfall and its distribution pattern. When irrigation management was imposed as corrective measure, Minna upgraded to moderately suitable (S2) while Ijah-Gbagyi was marginally suitable (S3). On the basis of limitations of climate and soil factors, Minna could be more suitable for cultivation of oil palm.

**KEYWORDS:** Parametric land evaluation, plinthic soils, oil palm, Nigeria

## INTRODUCTION

Land suitability classification is an assessment of land in a particular location to determine its fitness for a specified use in a sustainable way (Boitt *et al.*, 2015). In terms of agricultural use, suitability classification is a function of matching crop requirements with soil or land quality/ characteristics to establish the suitability class of a particular land (Singha and Swain, 2016). Classification methodologies are principally grouped into qualitative and quantitative land evaluation (Baja *et al.*, 2007). In more recent time, quantitative approach was increasingly being used (Elsheik *et al.*, 2010) and hence, adopted for this study. In quantitative evaluation, numeric indicators, ranging from a scale of 0 to 100, are usually assigned in ranking land quality/ characteristics.

Oil palm, a perennial tree crop, originated from West Africa (Poku, 2002), particularly in Nigeria where records of its domestication dated as far back as some 5,000 years (Sridhar and Ade-Oluwa, 2009). Palm oil is a product extracted from the fleshy mesocarp of the palm fruit. It is a major food and non-food ingredient consumed by virtually every household in Nigeria, directly or indirectly, through the use of palm oil related products (Ohimain *et al.*, 2014). Nigeria was

once the world leading producer and exporter of palm oil in the sixties, but lost her leading status to Malaysia and Indonesia because of her poor commitment to oil palm production (Nnorom, 2012; Ohimain *et al.*, 2014). The drop in ranking was blamed on neglect of agriculture sector for petroleum products.

Plinthic soils or Plinthosols have a global coverage estimated at some 60 million hectares (WRB/IUSS Working Group, 2014). Plinthosols have a wide distribution in humid savanna grassland of north-central Nigeria including Jos Plateau (Ojanuga, 2006). They are formed from humus-poor iron-rich ferruginous materials, with genetic history of repeated wetting and drying, leading to formation of pisoliths (in form of gravels or concretions). These type of soils are associated with numerous management problems, ranging from low fertility, water-logging or drought (depending on their physiographic locations), to shallow rooting depth (WRB/IUSS Working Group, 2014). Suitability evaluation of this group of soils for tree crops, particularly oil palm, in this part of the country, that is north-central, Nigeria, have not been carried out. On this basis, this work was designed to characterize and evaluate the suitability of some plinthic



landscapes for oil palm production, based on a parametric (Square Root) method, in some locations (Minna and Ijah-Gbagyi) in Niger State, North-central Nigeria.

## MATERIALS AND METHOD

### Study Area

Niger State, Nigeria, lies between latitudes 8° 10' and 11° 31' N and longitudes 4° 30' and 7° 15' E in the Guinea savanna of zone of Nigeria. The state is covered by two major rock formations, that is, the sedimentary rocks (SR) to the south and basement complex rocks (BCR) to the north. To the west is some areas covered by Sokoto Basin (Fig. 1). The locations selected for the study were Minna (latitude 9° 25' N; longitude 6° 22' E, on 177 m above mean sea level) and Ijah-Gbagyi (latitude 9° 16' N and longitude 7° 15.327' E, on 466 m above mean sea level). The annual rainfall varies from 1600 mm in the south to about 1200 mm in the north usually spread between the months of May and October (Lawal *et al.*, 2012).

The study locations fall under sub-humid-Minna-Kaduna-Kafanchan High Plains consisting of gently undulating high plains developed on Basement Complex Rocks made up of granites, migmatites, gneisses and schists. Inselbergs of “Older Granites” and low hills of schists rise conspicuously above the plains. Beneath the plains, bedrock is deeply weathered and constitutes the major soil parent material. The soils derived from the weathered rocks are deep, weakly to moderately structured sand to sandy clay with gravelly and concretionary layers in the upper layer or beneath the surface layer (Ojanuga, 2006). The dominant soils have been classified as Typic Plinthustalfs (Lawal *et al.*, 2012; 2013; 2014). A wide range of crops such as grains, roots and tubers, legumes and vegetables are grown within the study areas, among them are maize, sorghum, rice, soybean and yam.

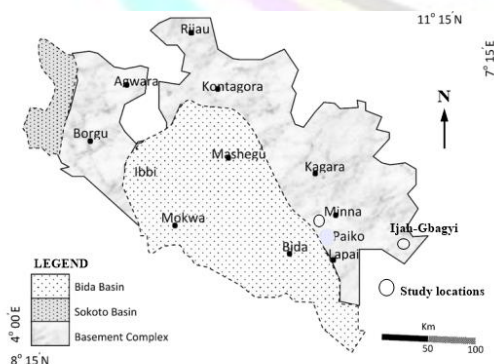


Figure 1: Geological map of Niger State, Nigeria, showing the study locations

### Field Work

The choice of the two locations (Minna and Ijah-Gbagyi), for this study was facilitated by previous works of Lawal *et al.* (2012; 2013). In each location, two representative profile pits were dug and described according to guidelines of Food and Agricultural Organization (FAO, 2006). Soil samples were collected, air-dried, gently crushed and passed through a 2 mm-sieve for routine laboratory analysis. The processed soil samples were analyzed for particle size distribution and some chemical properties following the procedures outlined by the International Soil Reference and Information Centre and Food and Agricultural Organization (ISRIC/FAO, 2002). Particle size analysis was determined by Bouyocous hydrometer method while soil pH in water (1:1) suspension was determined with pH meter. Organic carbon (C) was by Walkley-Black method. Exchangeable bases: calcium (Ca), magnesium (Mg), potassium (K) and sodium (Na) were extracted with neutral ammonium acetate (1N NH<sub>4</sub>OAc) solution and amounts Ca and Mg in solution were measured by atomic absorption spectrophotometer while K and Na were measured by flame photometer. Cation exchange capacity (CEC) was determined by the neutral 1 N NH<sub>4</sub>OAc saturation method, while percent base saturation was by calculation.

### Land Suitability Evaluation

The land suitability evaluation for oil palm was carried out using Square Root method. Land requirements for oil palm are shown in Table 1. Data from field observations and laboratory characterization were used in the evaluation. Key environmental factors used were climate, soil physical characteristics and drainage, topography of the land, nutrient availability and nutrient retention capacity. Index of suitability for each soil unit was calculated using the Square Root equation (Khiddir, 1986) below:

$$I = R_{\min} \times \sqrt{\frac{A}{100} \times \frac{B}{100} \times \frac{C}{100} \times \dots}$$

Where I is the index (%) of suitability, Rmin is the minimum rating of the environmental factors and A, B, C ... are other factor ratings besides the minimum. The overall suitability was assigned by converting the index values to their corresponding land suitability classes (Table 2).

## RESULTS AND DISCUSSION

### Soil/land characteristics and management implications

Information on land characteristics/ land quality are presented in Table 3. Mean annual rainfall for Minna and Ijah-Gbagyi was 1284 mm and 1016 mm (Lawal *et al.*, 2012; 2013) respectively. Daily temperature for Minna rarely falls below 22 °C with monthly mean of 34 °C (Ojanuga, 2006; Adeboye *et al.*, 2011), while Ijah-Gbagyi had average of 33 °C (Lawal *et al.*, 2013), which was marginally suitable for oil palm cultivation. Length of dry months for the two locations was 5-6 months, above the critical duration period of 4 months established as normal for optimum performance of oil palm (Djaenudin *et al.*, 2003).

The soils of Minna have dark brown (10YR3/3) color at the surface which graded to dark yellowish brown (10YR4/4) in the subsoil. Ijah-Gbagyi have dark yellowish brown (10YR3/4) overlaying various shades of light yellowish brown in the subsoil. The texture is sandy clay loam at the surface over gravely sandy clay at subsoil, while Ijah-Gbagyi have gravely sandy loam over gravely sandy clay loam subsurface. The gravely nature of soils in both locations may create difficulties particularly in rooting. According to Babalola and Lal (1977), gravels pose problems to root penetration and proliferation. Poor to imperfect drainage conditions at the substratum in both locations might be linked to accumulation and subsequent cementation of the gravely layer by clay, starting from the depth of 29 to 73 cm from surface. Since oil palm is sensitive to wet conditions, with implications in poor growth and yields (Arshad, 2014), drainage should be taken into consideration during the rainy seasons. Management problems associated with plinthic soils particularly on water-logging or drought have been pointed out earlier in this report.

Mean soil pH values were 5.9 and 5.3 for Minna and Ijah-Gbagyi respectively, and was fit for cultivation of oil palm. According to Djaenudin *et al.* (2003), oil palm is tolerant to acid soils with pH range of 4.2 to 6.0. Organic C was medium in Minna to high in Ijah-Gbagyi, which was unusual for plinthic soils. Medium to high organic carbon in the soils may imply practice of low intensity farming in both locations. Thus, maintaining the status of organic matter in these soils may immensely preserve the high cation retention capacities and nutrient reserves of the soils. Currently, cation exchange capacity of the soils was high, 18.64 and 13.05 cmol kg<sup>-1</sup> for Minna and Ijah-Gbagyi respectively. Base saturation was high (90 %) in Minna and medium (67 %) in Ijah-Gbagyi, suggesting dominance of basic cations in the exchange surfaces of the soils (Atoforati *et al.*, 2012).

### Land Suitability Classification by Land Characteristics

Results of suitability evaluation after matching land characteristics (Table 3) with environmental requirements of oil palm (Table 1) are presented in Table 4. The actual suitability considers the land in its original condition without any improvement measures imposed at the time of evaluation (Arshad, 2014). In this context, the current status of both locations was found not suitable (N1) for oil palm. The indices of productivity (IPc) were 20.4 % and 10.9 % respectively for Minna and Ijah-Gbagyi. These values were below 25 % established as the critical limit (Van Ranst and Verdoort, 2005). Major limitations for both locations are climatic factors: rainfall and length of dry months which exceeded 4 months established as critical for normal growth of oil palm (Djaenudin *et al.*, 2003). Shallowness of the soils in Ijah-Gbagyi constituted to be additional limiting factor for oil palm.

The potential suitability of any parcel of land refers to its suitability after improvement measures have been made on the land (Arshad, 2014). In this regard, since soil depth cannot be manipulated, rainfall/duration can be augmented by irrigation. By imposing irrigation, the two locations potentially become suitable with index values of 55.3 and 29.4 % respectively for Minna and Ijah-Gbagyi. Thus, Minna graded to moderately suitable (S2) and Ijah-Gbagyi was marginally suitable (S3).

### CONCLUSION AND RECOMMENDATIONS

On the basis of the parametric approach used in classifying these landscapes, results revealed that both locations, in their natural status are not suitable for the cultivation of oil palm. To make these plinthic landscapes suitable, irrigation must be practiced to augment water deficit. Aside from irrigation, since oil palm cannot perform optimally under poor drainage condition, poor internal drainage characteristics of these soils should be closely managed. Minna had higher potentials for oil palm cultivation. It is more likely to give higher yields compared to Ijah-Gbagyi which was characterized with shallow soil depth as additional limitation.

### ACKNOWLEDGEMENTS

The authors acknowledged the proprietor of Baba Kajegna Farms, Ijah-Gbagyi, Niger State of Nigeria for granting access to use the premises of its farmland and also financial support toward successful execution of part of field works, particularly in Ijah-Gbagyi sector.

Table 1: Requirements for growth of oil palm (*Elaeis guineensis*)

Land use requirements / Land characteristics	Land suitability class			
	S1	S2	S3	N
<b>Temperature regime (tc)</b>				
Annual average temperature	25-28	22-25 28-32	20-22 32-35	< 20 > 35
<b>Water availability (wa)</b>				
Average annual rainfall (mm)	1700-2500	1450-1700 2500-3500	1250-1450 3500-4000	< 1250 > 4000
Dry months	< 2	2-3	3-4	> 4
<b>Oxygen availability (oa)</b>				
Drainage	Good, moderate	Moderate, poor	Poor, moderate, rapid	Very poor, rapid
<b>Rooting conditions (rc)</b>				
Soil texture (surface)	Fine, slightly fine, medium	-	Slightly coarse	Coarse
Coarse material (%)	< 15	15-35	35-55	> 55
Soil depth (cm)	> 100	75-100	50-75	< 50
<b>Nutrient retention (nr)</b>				
CEC-clay (cmol kg <sup>-1</sup> )	> 16	≤ 16	-	-
Base saturation (%)	> 20	≤ 20	-	-
pH H <sub>2</sub> O	5.0-6.0	4.2-5.0 6.5-7.0	< 4.2 > 7.0	- -
Potassium	> 1.5	1.2-1.5	< 1.2	-
Organic C (g kg <sup>-1</sup> )	> 8.0	≤ 8.0	-	-
<b>Toxicity (xs)</b>				
Salinity (ds/m)	< 2	2-3	3-4	> 4
<b>Erosion hazard (eh)</b>				
Slope (%)	< 8	8-16	16-30	> 30
Erosion hazard (eh)	Very low	Low-moderate	Severe	Very severe
<b>Flood hazard (fh)</b>				
Flooding	F0	F1	F2	> F2
<b>Land preparation (lp)</b>				
Surface stoniness (%)	< 5	5-15	15-40	> 40
Rock out crops (%)	< 5	5-15	15-25	> 25

NB: S1 = highly suitable; S2 = moderately suitable; S3 = marginally suitable; N = not suitable  
Source: Modified from Djaenudin *et al.* (2003)

Table 2: Index values for the different land suitability classes

Land Index (%)	Suitability Class	Definition
100-75	S1	highly suitable
75-50	S2	moderately suitable
50-25	S3	marginally suitable
25-12.5	N1	Currently not suitable
12.5-0	N2	Permanently not suitable



Table 3: Land quality/ characteristics of the study locations

Land quality/characteristics	Location	
	Minna	Ijah-Gbagyi
Mean annual rainfall (mm)	1284	1016
Average length of dry season (months)	6	6
Temperature (mean annual) °C	33.5	33
Slope (%)	< 2	3
Drainage	Imperfectly drained	Imperfectly drained
Flooding	F0	F0
Soil depth to gravely/indurated layer (cm)	83	36
Texture	SCL/SC	SL/SCL
Surface Stoniness (%)	0	< 3
Rock out crops (%)	0	0
Soil reaction (pH)	5.9	5.3
Organic carbon (g kg <sup>-1</sup> )	10.68	30
Cation exchange capacity (cmol kg <sup>-1</sup> )	18.68	13.05
Base saturation (%)	90	67

NB: SCL = sandy clay loam, SC = sandy clay, SL = sandy loam, F0 = flood free.

Table 4: Suitability ratings of land characteristics of the study location for oil palm production

Factor	Minna		Ijah-Gbagyi	
	Actual	Potential	Actual	Potential
Topography (t):				
-Slope	100	100	100	100
Drainage (w):				
-wetness	85	100	85	100
-Flooding hazard	100	100	100	100
Climate (c):				
-Rainfall	60	100	40	100
-Temperature	60	60	60	60
Length of dry season (months)	40	100	40	100
Soil physical characteristics (s):				
-Texture	100	100	100	100
-Soil depth	85	85	40	40
Surface stoniness	100	100	95	95
Rock out crop	100	100	95	95
Nutrient availability (f):				
-Soil reaction (pH)	100	100	100	100
-Potassium				
Nutrient retention (n):				
-Organic carbon	100	100	100	100
-Cation exchange capacity (CEC)	100	100	85	85
-Base saturation	100	100	100	100
<b>Suitability Index (%)</b>	<b>20.4</b>	<b>55.3</b>	<b>10.9</b>	<b>29.4</b>
<b>Suitability Class*</b>	<b>N1c</b>	<b>S2c</b>	<b>N1sc</b>	<b>S3s</b>

NB: N1 = currently not suitable, S2 = moderately suitable, S3 = marginally suitable, c = climatic limitation, s = soil limitation.

## REFERENCES

- Adeboye, M.K.A., Bala, A., Osunde, A.O., Uzoma, A.O., Odofin, A.J. & Lawal, B.A. (2011). Assessment of soil quality using soil organic carbon and total nitrogen and microbial properties in tropical agroecosystems. *Agricultural Sciences*, 2(1): 34-40.
- Arshad, A.M. (2014). Qualitative Land Evaluation for Oil Palm Cultivation in Peninsular Malaysia. *Journal of Biology, Agriculture and Healthcare*, 4(1): 69-76.
- Atofarati S.O., Ewulo B.S. and Ojeniyi, S.O. (2012). Characterization and classification of soils on two toposequence at Ile-Oluji, Ondo State, Nigeria. *International Journal of AgriScience*, 2(7): 642-650.
- Babalola, O. and Lal, R. (1977). Subsoil gravel horizon and maize root growth. *Plant and Soil*, 46: 347-357
- Baja, S., Chapman, D.M. & Dragovich, D. (2007). Spatial based compromise programming for multiple criteria decision making in land use planning. *Environmental Modelling and Assessment*, 12: 171-184.
- Boitt, M.K., Mundia, C.N., Pellikka, P.K.E. and Kapoi, J.K. (2015). Land Suitability Assessment for Effective Crop Production, a Case Study of Taita Hills, Kenya. *Journal of Agricultural Informatics*, 6(2):23-31.
- Djaenudin, D., Marwan, Subagyo, H., Hidayat, A. (2003). Petunjuk Teknis Evaluasi Lahan untuk Komoditas Pertanian. Edisi Pertama. Balai Penelitian Tanah, Bogor.
- Elijah, I.O., Cletus, I.E., Sylvester, C.I. and Dorcas, A.E. (2014). Small-Scale Palm Oil Processing Business in Nigeria: A Feasibility Study. *Greener Journal of Business and Management Studies*, 4(3): 070-082.
- Elsheik, A.R., Ahmad, N., Shariff, A., Balasundra, S. and Yahaya, S. (2010). An agricultural investment map based on geographic information system and multi-criteria method. *Journal of Applied Sciences*, 10:1596-1602
- FAO (2006). Guidelines for Soil Description. 4<sup>th</sup> edition. Food and Agriculture Organization of the United Nations, Rome, Italy. 97pp.
- ISRIC/FAO (2002). Procedures for Soil Analysis. Sixth edition. L.P. van Reeuwijk (ed). International Soil Reference and Information Centre / Food and Agricultural Organization, 119pp.
- Khiddir, S.M. (1986). A statistical approach in the use of parametric systems applied to the FAO framework for land evaluation. Ph.D. Thesis, Ghent University, Ghent, Belgium. 141pp
- Lawal, B.A., Adeboye, M.K.A. Tsado, P.A., Elebiyo, M.G. & Nwajoku, C.R. (2012). Properties, classification and agricultural potentials of lateritic soils of Minna in sub-humid agroecological zone, Nigeria. *International Journal of Development and Sustainability*, 1(3):903-911.
- Lawal, B.A., Adeboye, M.K.A., Mbaoji, C., Abbah, I.M. and Abdulsarak, Y.L. (2014). Assessment of some micronutrients in profiles of Typic Plinthustalfs in Minna, southern Guinea savanna, Nigeria. *Nigerian Journal of Soil and Environmental Research*, 12: 107-114.
- Lawal, B.A., Ojanuga, G.A., Tsado, P.A. and Mohammed, A. (2013). Characterization, classification and agricultural potentials of soils on a toposequence in southern Guinea savanna of Nigeria. *International Journal of Biological, Veterinary, Agricultural and Food Engineering*, 7(5): 141-145.
- Ojanuga, A.G. (2006). Agroecological Zones of Nigeria Manual. FAO/NSPFS, Federal Ministry of Agriculture and Rural Development, Abuja, Nigeria, 124pp.
- Poku, K. (2002). Small-Scale Palm Oil Processing in Africa. Rome, Italy: Agriculture Services Bulletin 148. Food and Agricultural Organization of the United Nations
- Singha, C. and Swain, K.C. (2016). Land suitability evaluation criteria for agricultural crop selection: A review. *Agricultural Reviews*, 37(2): 125-132.
- Sridhar, M.K.C. and Ade-Oluwa, O.O. (2009). Palm Oil Industry Residue. In: Biotechnology for Agro-Industrial Residues Utilization. Nigam, P.S. and Pandey, A. (Eds.). Springer Science. Pp 341-355.
- Teoh, C.H. (2002). The palm oil industry in Malaysia - from seed to frying pan. A report prepared for WWF Switzerland. Selangor, Malaysia. Pp. 1-59.
- Van Ranst, E. & Verdoort, A. (2005). Land Evaluation Part II: Qualitative Methods in Land Evaluation. International Centre for Physical Land Resources, Ghent, Belgium. 150pp.
- WRB/IUSS Working Group (2014). World Reference Base for Soil Resources 2014. International soil classification system for naming soils and creating legends for soil maps. World Soil Resources Reports No. 106, FAO, Rome. 181pp.

## ANALYSIS OF ARTISANAL AND CULTURED FISH PRODUCTION IN NIGER STATE, NIGERIA

Tsado, J.H., Nmadu J.N., Baba K.M., Jirgi A.J., Ebiloma G.C.  
Department of Agricultural Economics and Extension Technology,  
Federal University of Technology, Minna, Nigeria.

\* Email: [jacobtsado2007@yahoo.com](mailto:jacobtsado2007@yahoo.com) 08065268098

### ABSTRACT

This study was conducted in Niger State, Nigeria to analyze artisanal and cultured fish production in the state. The data for this study was collected using questionnaires and interview schedules from 100 and 80 randomly selected cultured fish farmers and artisanal fish farmers (fishermen) respectively. Descriptive and inferential statistics were mainly used for the analysis. The results of the study revealed that majority of the respondents (69.4%) were still in their active and productive age and a large proportion (75.6%) were married and a moderate household size of between 4-6 persons. Also majority (69.4%) had one form of education or the other. The result shows that majority of the respondents (53.33%) were on the extra-large (above 15,000fishes) scale of production and fish produced from artisanal fishing (mean=16377 fishes) was greater than the fish produced by cultured fish farming (14216 fishes). The result shows that marital status, age and years of fishing experience were significant socio-economic factors that affect the level of fish production. Fish productions were faced with many problems such as depletion of fish stocks for the artisanal production and poor source of fingerlings for the cultured production. It is recommended that Government and NGOs should train the fishermen on artisanal fishing to stop over-exploitation/indiscriminate catch of wild fish and also training on how to domesticate the wild catches so as to increase production.

**KEYWORDS:** Artisanal, Cultured, Fish production

### INTRODUCTION

Nigeria is the largest fish consumer in Africa and among the largest fish consumers in the world with over 1.5 million tons of fish consumed annually. Yet, Nigeria imports over 900,000 metric tons of fish while its domestic catch is estimated at 450,000metric tons/year (Ozigbo *et al.*, 2013) making it among the largest importers of fish in the developing world. Considering its vast mangrove ecosystem, Nigeria is said to have a great potential to achieve sustainable fish production. The country's annual domestic fish supply stands at an estimate of about 400,000 tonnes (Adebayo and Daramola, 2013). Nigeria has the natural resources (such as lands, rivers, streams, reservoirs and lakes; and human resource) and potentials to compete with the world leading aquaculture countries. Nigeria has about 264 medium and large dams with a combined storage capacity of 33 billion cubic meters of water. Of these dams, 210 are owned by the Federal Government, 34 are owned by states, while 20 are owned by private organizations (Ukuedojor, 2013).

Artisanal fishing is the hunting of self-reproducing stocks of wild fish in a very harsh environment over which man has almost no control (Gorden, 1993). According to Williams (1995), it is the finding and capturing of wild species of fish that the fisherman cannot see in vast and largely barren areas of rivers,

lakes and streams. Harvesting water products by diving in deeper waters, wading in shallow waters without the help of boats, tools and only using simple gears or hands have been known for millions of years to the present day (Coul, 1983; FAO, 2002). The fundamental understanding by fishermen of the behavior of fish enables them to outwit the fish and catch it even with simple gear. This knowledge of fish behavior according to Wheatson and Lawson (1981) as well as FAO (1993) is falling fast into oblivion as a result of emergence of many sophisticated machines to operate fishing gears automatically and the development of electronic equipments for searching and finding fish in water.

Aquaculture activities in Nigeria started about 50 years ago (Olagunju *et al.*, 2007), yet Nigeria has not been able to meet domestic production demand for the populace. According to Ekunwe and Emokaro (2009), statistics indicate that Nigeria is the largest African aquaculture producer, with production output of over 15,489tonnes per annum; this is closely followed by Egypt with output of about 5,645 tonnes. Only five other countries: Zambia, Madagascar, Togo, Kenya and Sudan produce more than 1,000tonnes each. This result shows that Africa in general is far behind in aquaculture production. However, according to FAO (2012) report, Egypt is highest producer of aquaculture in 2010 with



919585tonnes of total Africa production followed by Nigeria with 200535tonnes. In Nigeria, aquaculture development has been driven by social and economic objectives, such as nutrition improvement in rural areas, generation of supplementary income, diversification of income activities, and the creation of employment. This is especially true in rural communities, where opportunities for economic activities are limited. Only in recent years has aquaculture been viewed as an activity likely to meet national shortfalls in fish supplies, thereby reducing fish imports. The fisheries sector accounts for about 2% of national G.D.P, 40% of the animal protein intake and a substantial proportion of employment, especially in the rural areas; the sector is a principal source of livelihood for over three million people in Nigeria (Adedeji and Okocha, 2011).

Despite the abundant human and non-human resources that the nation is blessed with, the country is yet to bridge the gap between the demand and supply of fish, thereby making the nation one of the protein deficient nations. Local fish production has failed to meet the country's domestic demand (FAO, 1995), despite these considerably high potentials the nation has. The fish industry remains the most virgin investment in Nigeria compared with the importation of frozen fish in the domestic market (Ndu, 2006). A sure means of substantially solving the demand-supply gap is by embarking on widespread homestead/small scale fish production (Kudi *et al*, 2008). However, the sources of this effort must be anchored on the analysis of fish production. .

The objectives are to: describe the socio- economic characteristics of the respondents; determine the level of fish production; determine the socio-economic factors affecting the level of fish production; examine the constraints associated with fish production and the respondent's perception of the constraints in the study area.

**METHODOLOGY**

This study was carried out in Niger State, Nigeria. Generally, agricultural activities form the mainstay of the State's economy and engage directly or indirectly more than 80 percent of the population.

A multistage sampling technique was adopted for the selection of respondents for this study. The first stage involved a purposive selection of one LGA each for the cultured and artisanal fish production in Niger state which was Borgu LGA for the cultured fish production and Mokwa LGA for the artisanal fish production as these are locations where the respondents are concentrated. The second stage was

random selection of 20% of the total respondents in each of the local government area, making a total sample size of 180 respondents from a total sample frame of 900 respondents. There is a table below to describe the sampling process. The data for this study was collected using questionnaires and interview schedules that were administered by the researcher with the assistance of trained enumerators.

Descriptive such as frequencies, percentages, and means and inferential statistics Ordered logit regression model was used to achieve to determine the factors that influence fish production. 3-point likert type of scale was used to analyze the respondents' perception on the constraints associated with fish production in Niger State. For respondents' perception on the constraints, the Likert rating scale of Severe (3 points), Not-sure (2 points), and Not a constraint (1 points) was used to obtain the main scores. The critical mean 2.0 derived from 3-point likert rating scale values (3+2+1)/4 was used to describe fish farmers' perceptions of the constraints faced. The constraints scores greater than or equal to critical mean of 2.0 depicts serious constraint to fish production.

The Ordered logit regression model is specified in equation 1

$$\ln(Y_i) = \alpha_i + \beta X_i \dots \dots \dots (1)$$

The level of production of the fish farmers was rated on this scale: Small (1), Medium (2), Large (3), and Extra-large (4).

The functional form is expressed in the explicit form as:

$$Y_i = b_0 + b_1X_1 + b_2X_2 + b_3X_3 + b_4X_4 + b_5X_5 + b_6X_6 + b_7X_7 + b_8X_8 + b_9X_9 + b_{10}X_{10} + b_{11}X_{11} + E.$$

- Y<sub>i</sub> = Level of fish production (Quantity produced)
- X<sub>1</sub> = Age of the fish farmer (year)
- X<sub>2</sub> = Gender of the farmer (Male/Female)
- X<sub>3</sub> = Marital Status (Single/Married)
- X<sub>4</sub> = Household Size (Number of members in the family)
- X<sub>5</sub> = Years of fish farming experience
- X<sub>6</sub> = Number of Years spent in Formal Education (years)
- X<sub>7</sub> = Annual Income (₦)
- X<sub>8</sub> = Access to Credit (₦)

$X_9$  = Access to extension services (number of contact)

$X_{10}$  = Access to training (number of times training received)

$X_{11}$  = Cooperative membership (number of cooperatives)

$b_1 - b_{11}$  = Regression coefficients

$b_0$  = Constant

E = Error term.

## RESULTS AND DISCUSSION

### Socio-Economic Characteristics of Artisanal Fish Farmers and Cultured Fish Farmers

Table 1 shows the results of the Socio-economic characteristics of both artisanal fish and cultured fish farmers. The socio-economic characteristics include age, sex, marital status, household size, education level, years of fish farming/fishing experience and primary occupation. According to the results in Table 1, majority of the artisanal fish farmers were between the ages of 41-60 years while for the cultured fish farmers, majority were between the ages of 20-40 years. The pooled result shows that the active years for both fishing (Capture) and fish farming (cultured) is between 20-40 years. The mean age of cultured fish farmers is 42.9 years. The mean age of artisanal fish farmers is 43.9 years. Table 1 revealed that the total number of respondents for artisanal fishing were male while for cultured fishing, 95% of the respondents were male. This agrees with the findings of Ele (2008) that artisanal fishing is dominated by male. Majority of the respondents for both artisanal fishing and cultured fishing were married, 73.8% and 77.0% respectively. For artisanal fishing, majority of the respondents had a household size of above 7 persons while for cultured fishing, majority had a household size of 4-6 persons. Majority of respondents had no formal education and were secondary school certificate holders for artisanal fishing and cultured fishing respectively.

### Level of Fish Production of Artisanal Fish Farmers and Cultured Fish Farmers

Table 2 shows the level of fish production of artisanal fish farmers and cultured fish farmers. The results from Table 2 revealed that majority of the respondents were on the Extra-large scale of Fish production level, having 68.8%, 41.0% and 53.33% for artisanal fish farmers, cultured fish farmers and pooled respectively. The average quantity of fish produced by cultured fish farmers under study was

14216 fishes while the average quantity of fish produced by artisanal fish farmers was 16377 fishes.

### Socio-Economic Factors that Affect the Level of Fish Production

The socio-economic factors affecting level of fish production, for both artisanal and cultured practices was analyzed using ordinal logit regression analysis. The results are presented in Table 3. The model had a pseudo  $R^2$  value of 0.5973 for cultured fish production, which implies that about 59.73% of the variation in Level of fish production was explained by the variables included in the model while the remaining 40.27% was as a result of the non – inclusion of other important explanatory variables, as well as errors in estimation. And a pseudo  $R^2$  value of 0.8606 for artisanal fish production, which implies that about 86.06% of the variation in Level of fish production was explained by the variables included in the model while the remaining 13.94% was as a result of the non – inclusion of other important explanatory variables, as well as errors in estimation. The Chi-square (155.27) and (164.3) for cultured fish production and artisanal fish production respectively were statistically significant at 1% probability level. This implies that the explanatory variables adequately explained the model.

For cultured fish production, the result in Table 3 further indicated that out of the 6 variables included, only two were statistically significant at explaining the level of fish production. These include marital status (3.4694) and years of fish farming experience (1.9071) which were found to be significant at the 0.05 and 0.01 probability levels respectively. The coefficient years of fish farming experience was positively signed. This implies that there is a positive relationship between the years of fish farming experience and the level of fish production. In other words as the years of the cultured fish farmer experience increased, the level of production of fish also increased. This is plausible because increase in years of experience enable the farmer to set realistic production targets and to be more technically competent.

### Constraints Associated with Artisanal Fish Production

Table 4 presents the result of the constraints that are associated with artisanal fish production. The constraints associated with artisanal fish production were analyzed using 3-point likert scale, having 3-points as Severe, 2-points as Not-sure and 1-point as Not a constraint, with a mean average of 2.0. The results showed that the constraints faced by artisanal



fish farmers in the study area were above the mean score of 2.0. In ranking, the most common constraint faced by the artisanal fish farmers was depletion of fish stocks with a mean score of 2.96. This is due to indiscriminate fishing practices i.e using chemical to catch fishes and over-exploitation of the rivers, using nets that catches the smaller fishes at the fry stage.

### **Constraints Associated with Cultured Fish Production**

Table 5 presents the result of the constraints that are associated with cultured fish production. The constraints associated with cultured fish production were analyzed using a 3-points likert scale, having 3-points as Severe, 2-points as Not-sure and 1-point as Not a constraint, with a mean average 2.0. The result showed that the most common constraint experienced by cultured fish farmers was the poor source of fingerlings. Cultured fish farmers have reported the issues of cannibalism experienced in many ponds were as a result of the source of the fingerlings being poor and bad. Many of the suppliers mix up the fingerlings of different ages together and this leads to some getting matured before the others, thereby the more matured ones feed on the less matured ones and these has led to some farmers engaging in personal hatching practices.

### **CONCLUSION AND RECOMMENDATIONS**

From the study it can be concluded that the quantity of fish produced by artisanal fish farmers was greater than the quantity produced by cultured fish farmers. Artisanal fish farmers and cultured fish farmers that have been in the business of fishing/fish farming have more output than others who just enter the business and this is because increase in years of fishing/fish farming experience enables the artisanal fish farmers and cultured fish farmer to set realistic production targets and to be more technically competent. Depletion of fish stocks or species in the water body was a major constraint prevailing in the area as regarding artisanal fish production as this is due to indiscriminate fishing practices carried out in the area i.e. using chemical to catch fishes and over-exploitation of the rivers, using nets that catch the smaller fishes at the fry stage. Poor source of fingerlings was a major constraint prevailing in the area as regarding cultured fish production as this leads to some getting matured before the others; thereby the more matured ones feed on the less matured ones (cannibalism). It is recommended that Government and NGOs should train the fishermen on artisanal fishing to stop over-exploitation/indiscriminate catch of wild fish and also training on how to domesticate the wild catches so as to increase production. And that Government,

Agricultural institutions, Non-Governmental Organizations (NGOs) and the fish farmers should provide adequate capital to establish better and adequate hatcheries certified by the government, having been equipped with the technical know-how of good hatching process, to produce good fingerlings so as to reduce the issue of cannibalism in many ponds.



**Table 1: Socio-economic Characteristics of Artisanal Fish Farmers and Cultured Fish Farmers**

Socio-economic Variable	Artisanal Fish Farmers		Cultured Fish Farmers		Pooled	
	Frequency	Percentage	Frequency	Percentage	Frequency	Percentage
<b>Age</b>						
Below 20 years	10	12.5	5	5.0	15	8.3
20 - 40 years	20	25.0	45	45.0	65	36.1
41 - 60 years	30	37.5	30	30.0	60	33.3
Above 60 years	20	25.0	20	20.0	40	22.2
Total	80	100.0	100	100.0	180	100.0
<b>Sex</b>						
Male	80	100.0	95	95.0	175	97.2
Female	0	0.0	5	5.0	5	2.8
Total	80	100.0	100	100.0	180	100.0
<b>Marital Status</b>						
Married	59	73.8	77	77.0	136	75.6
Single	21	26.3	23	23.0	44	24.4
Total	80	100.0	100	100.0	180	100.0
<b>Household Size</b>						
1 - 3 persons	23	28.8	30	30.0	53	29.4
4 - 6 persons	11	13.8	48	48.0	59	32.8
Above 7 persons	46	57.5	22	22.0	68	37.8
Total	80	100.0	100	100.0	180	100.0
<b>Educational Level</b>						
Primary	28	35.0	23	23.0	51	28.3
Secondary	15	18.8	30	30.0	45	25.0
Post-Secondary	0	0.0	29	29.0	29	16.1
No formal Educational	37	46.3	18	18.0	55	30.6
Total	80	100.0	100	100.0	180	100.0
<b>Years of Fishing Experience</b>						
Below 10 years	12	15.0	95	95.0	107	59.4
10 - 20 years	12	15.0	5	5.0	17	9.4
21 - 40 years	10	12.5	0	0.0	10	5.6
Above 30 years	46	57.5	0	0.0	46	25.6
Total	80	100.0	100	100.0	180	100.0
<b>Primary Occupation</b>						
Fishing	62	77.5	0	0.0	62	34.4
Fish Farming	0	0.0	61	61.0	61	33.9

Civil Servant	8	10.0	19	19.0	27	15.0
Trading	10	12.5	20	20.0	30	16.7
Total	80	100.0	100	100.0	180	100.0

Source: *Meso*-field survey, 2018

**Table 2: Level of Fish Production of Artisanal Fish Farmers and Cultured Fish Farmers**

Quantity Produced	Artisanal Fish Farmers		Cultured Fish Farmers		Pooled	
	Frequency	Percent	Frequency	Percent	Frequency	Percent
SMALL (Less 5,00 fishes)	9	11.3	12	12.0	21	11.67
MEDIUM (5,000 - 10,000 fishes)	7	8.8	25	25.0	32	17.78
LARGE (10,001 - 15,000 fishes)	9	11.3	22	22.0	31	17.22
EXTRA-LARGE (Above 15,000 fishes)	55	68.8	41	41.0	96	53.33
TOTAL	80	100.0	100	100.0	180	100.00

Source: *Meso*-field survey, 2018

**Table 3: Socio-Economic Characteristics affecting the Level of Fish Production**

Variables	Artisanal Fish Farmers	Cultured Fish Farmers
	Coefficient(z-values)	Coefficient(z-values)
Age (X1)	0.7100(1.82*)	0.0378(0.65)
Gender(X2)	-	0.6900(0.62)
Marital Status(X3)	-0.5477(-0.24)	3.4694(1.98**)
Household size(X4)	-1.7104(-1.80*)	0.0621(0.17)
Formal Education(X5)	0.005(0.00)	0.0039(0.06)
Years of Fish farming/Fishing Experience(X6)	0.9482(2.60***)	1.9071(4.70***)
LR Chi-Square	164.3***	155.27***
Pseudo R-Square	0.8606	0.5973

Source: *Meso*-field survey, 2018. \*\*\*, \*\* and \* @ 1%, 5%, and 10% significance level.

**Table 4 Constraints associated with Artisanal Fish Production**

Constraints	Severe	Not –Sure	Not Constraint <sup>a</sup>	Total Score	Mean	Ranking
Depletion of fish stocks	77(96.25)	3(3.75)	0(0.0)	237	2.96	1 <sup>st</sup>
Lack of Credit facilities	75(93.75)	4(5.0)	1(1.25)	234	2.93	2 <sup>nd</sup>
High Cost of Processing/Storage facilities	69(86.25)	6(7.5)	5(6.25)	224	2.8	3 <sup>rd</sup>
Absence of Extension Services	59(73.75)	17(21.25)	4(5.0)	215	2.69	4 <sup>th</sup>
High Cost of fishing gears	60(75.0)	11(13.75)	9(11.25)	211	2.64	5 <sup>th</sup>
Low Income from poor catch	56(70.0)	18(22.5)	6(7.5)	210	2.63	6 <sup>th</sup>
Lack of Storage facilities	28(35.0)	43(53.75)	9(11.25)	179	2.24	7 <sup>th</sup>
Lack of Processing facilities	30(37.5)	32(40.0)	18(22.5)	172	2.15	8 <sup>th</sup>

Source: *Meso*-field survey, 2018

**Table 5 Constraints associated with Cultured Fish Production**

Constraints	Severe	Not –Sure	Not a Constraint	Total Score	Mean	Ranking
Poor Source of fingerlings	76(76.0)	12(12.0)	12(12.0)	264	2.64	1 <sup>st</sup>
High cost of Inputs	75(75.0)	12(12.0)	13(13.0)	262	2.62	2 <sup>nd</sup>
Unfavorable weather conditions	71(71.0)	18(18.0)	11(11.0)	260	2.6	3 <sup>rd</sup>
Lack of Organized Market	68(68.0)	22(22.0)	10(10.0)	258	2.58	4 <sup>th</sup>
Theft	56(56.0)	39(39.0)	5(5.0)	251	2.51	5 <sup>th</sup>
Lack of good water supply	59(59.0)	28(28.0)	13(13.0)	246	2.46	6 <sup>th</sup>
Poor Hatching techniques/skills	43(43.0)	15(15.0)	42(42.0)	201	2.01	7 <sup>th</sup>
Disease and Pest	31(31.0)	30(30.0)	39(39.0)	192	1.92	8 <sup>th</sup>

Source: *Meso*-field survey, 2018

### REFERENCES

- Adebayo, O.O and Daramola, O.A (2013). Economic analysis of catfish (*Clarias gariepinus*) production in Ibadan metropolis. Department of Agricultural Economics and Extension, Ladoke Akintola University of Technology Ogbomosho, Nigeria.
- Adedeji O.B, Okocha R.C (2011). Constraint to Aquaculture Development in Nigeria and Way Forward. Veterinary Public Health and Preventive Medicine, University of Ibadan, Nigeria.
- Amiengheme P. 2005. The Importance of Fish in Human Nutrition. A paper delivered at a Fish Culture Forum, Federal Department of Fish Farmers, Abuja.
- Coul, R. J. (1993). *World Fisheries Resources*. Routledge Pub. Company. London.
- Ekunwe P.A, Emokaro C.O (2009). Technical Efficiency of Catfish Farmers in Kaduna, Nigeria *Journal of Applied Sciences Research*; 5(7):802-805.
- Ele, I. E. (2008). An empirical analysis of fish production in the major fishing systems of the Cross River Basin, Nigeria. Unpublished Ph.D thesis, University of Calabar.
- FAO, Food and Agriculture Organization of the United Nations (1995). *The State of World: Fishery and Agriculture*. Fisheries Department, Rome.
- FAO, Food and Agriculture Organization of the United Nations. *The State of the World Fisheries and Aquaculture* FAO, Rome Italy; 2012.
- Food and Agricultural Organisation (1993): “Experiences in Community Based Management”: Discussion Guide, FAO Fisheries Report 2 (474) Rome pp 552-555.
- Food and Agricultural Organization (2002). “Promoting the Contribution of Sustainable Livelihoods Approach and the Code of Conducts for Responsible Fisheries in Poverty Alleviation.” FAO Fisheries Report No.678 (Sustainable Livelihoods Programme, 2002).
- Gorden, C. E. (1993) *Engineering, Economics and Fisheries Management*. Buckland Foundation Books.
- Kudi, T. M., Bako, F. P. and Atala, T. K. (2008) Economics of Fish Production in Kaduna State Nigeria. *Journal of Agricultural and Biological Science*. Asian Research Publishing Network (ARPN), Vol 3 (5&6).
- Ndu N.R (2006). Fish Farm Layout, Pond Construction, Management and Maintenance-Hatchery Techniques. A paper presented at the National Workshop on the Principles and Techniques of Fish Farming organized by Nigerian Agricultural, Cooperative and Rural Development Bank Kaduna with collaboration of Life Riches Consulting.



Olagunju F.I, Adesiyani I.O, Ezekiel A.A (2007). Economic viability of Cat fish production in Oyo state, Nigeria. *J. Hum. Ecol*; 21(2):121–124.

Ozigbo E., Anyadike C., Adebite O., and Kolawole P. (2013). Review of Aquaculture Production and Management in Nigeria. Department of Agricultural and

Bioresources Engineering, University of Nigeria Nsukka.

Ukuedojor M. (2013). Adequate drinking water still a tall dream in Nigeria. *Weekly Trust*. Saturday, 05 January.

Wheatson, F.W and Lawson T.B (1981) *Preservation of Aquacultural Products*.



## EFFECT OF CLIMATE CHANGE ON FOOD SECURITY AND WELL-BEING OF RICE FARMERS IN KEBBI AND NASARAWA STATES, NIGERIA

Fatoki<sup>1\*</sup>, P. O., J. H. Tsado<sup>2</sup>, O. J. Ajayi<sup>3</sup> I. T. Salihu<sup>4</sup>

Department of Agricultural Extension and Rural Sociology, Federal University of Technology, Minna, Niger State, Nigeria

E-mail: [philipfatoki@yahoo.com](mailto:philipfatoki@yahoo.com), GSM: [08037200004](tel:08037200004)

### ABSTRACT

*The study investigated the effect of climate change on food security and well-being status of rice farmers in Kebbi and Nasarawa States, Nigeria. Multi-stage sampling technique was used to sample a total of 361 rice farmers from the study areas. Data for the study were collected through the use of questionnaire and interview schedule. The data were analyzed using both descriptive and inferential statistics. Results showed that majority of the respondents (86.7%) were married with mean age of 40.1 years. The result of the well-being status of rice farmers in the study area using well-being indicators and its measurements revealed that the respondents were satisfied with the following well-being status: standard of living (5.94), health status (6.79), personal relationship (6.84), safety (5.87) and feeling part of community (7.54). The four most important climatic elements that had significant and positive effect on food security status of the respondents were temperature, desertification, drought and revenue losses at 1%, 10%, 1% and 5% levels of probabilities, respectively. Also the three most important climatic elements that had significant and positive effect on respondents' well-being status were temperature, sandstorm and desertification at 1%, 5%, and 5% levels of probabilities, respectively. It is recommended that government should put measures in place that will ensure farmers future security so as to motivate them to be more involved in agricultural activities ensuring household and national food security and consequently improve well-being.*

**KEYWORDS:** Climate change, food security status, well-being status, rice farmers

### INTRODUCTION

Climate change is perhaps the most serious environmental threat facing mankind world-wide currently. It affects agriculture for instance in several ways, one of which is its direct impact on food production. Climate change is already having an impact in Nigeria. Weather-related disasters have become more frequent in the past four decades and the trend continues. In 2010, the National Emergency Management Agency (NEMA) reported that over 250,000 Nigerians were displaced by flood disasters that ravaged many communities across the country with farmers recording produce losses (NEMA, 2010).

Nigeria is an integral part of the global ecosystem and so contributes to and is affected by global environmental problems (Ekong, 2003), these problems include deforestation, desertification, pollution, degradation of green house, gases emission. The effects of climatic elements and their extremes include the significant alteration of crop production; this is because crop yield is the product of both growth and development. Temperature and rainfall patterns provide major constraint on primary productivity, which in turn determines secondary productivity for instance; cassava growth failure can

result if rain does not fall at all under rain-fed agriculture, or if it does fall at the eastern states of the country, which can cause erosion and leaching of the soil nutrient leading to low output. According to a report published by the Federal Ministry of Environment (FME, 2006), Nigeria with a population of about 140 million and with an area of 932,000Km<sup>2</sup> with various activities being carried out by this vast population coupled with variability in elements of climate such as rainfall and temperature, exposes the country to impact of climate change. The negative impact of climate change such as temperature rise, erratic rainfall, sandstorms, desertification, low agricultural yield; drying up of water bodies and flooding, are real in many states of Nigeria. The indications that climate change is occurring are trend in warming temperatures, varying rainfall patterns, more frequent extreme weather events (such as storms, high rainfall intensity, floods, droughts, and heat waves).

Food security entails ensuring sustainable access, availability and affordability of adequate quantity and quality food to all citizens to meet up with their physiological requirements (Okuneye, 2014). When employed at the level of individual household members, food security implies an intake of food and

absorption of nutrients sufficient to meet differential individual needs for activity, health, growth and development. In essence, a country should be considered as food-secure when food is not only available in the quantity needed by the population consistent with decent living, but also when the consumption of the food should not pose any health hazard to the citizens (Davies, 2009). Food security is not narrowly defined as whether food is available, but, in addition, whether the monetary and non-monetary resources at the disposal of the population are sufficient to allow everyone access to adequate quantities and qualities of food (Schmidhuber and Tubiello, 2007). More specifically, the four dimensions of food security include: food availability; stability of food supplies; access to food; and food utilization. All these dimensions of food security status of farmers are likely to be affected by climate change: food security will depend not only on the direct impact of climate change on food production, but also (and critically so) on human development, economic growth, trade flows, and food aid policy (Keane *et al.*, 2009).

The concept of well-being is critical in enabling farmers to succeed in their personal and professional lives, but the well-being of farmers, like that of other groups, is complex and multifaceted with a range of determinants. The World Health Organization defines the well-being of any person, whether a farmer or not, as a state in which every individual realizes his or her own potential, can cope with the normal stresses of life, can work productively and fruitfully, and is able to make a contribution to her or his community. (World Health Organization 2013).

There is an increasing recognition that well-being is just as important a measure of progress as more traditional economic measures: an increasing number of national and international organisations are including assessments of well-being in their reporting (Helliwell *et al.*, 2013 and Durand, 2015). The word 'well-being' is used in different ways by different people, and is sometimes used interchangeably with related concepts such as 'quality of life'. In general (including in our use of the term) it refers not only to a person's health, but to their economic and social well-being more broadly.

It is often argued that farmers experience poorer mental health and well-being than non-farmers. Studies examining this have produced inconsistent results, most likely because not all farmers are the same, and different studies have looked at different groups of farmers. However, the results of a number of studies suggest that at least some groups of

Australian farmers have poorer mental and physical well-being than non-farmers (Berry *et al.*, 2011 and Schirmer *et al.*, 2013). It is critical to understand which farmers are experiencing higher and lower levels of well-being at particular points in time, and why. It is also important to understand how the act of farming itself influences the well-being of farmers. The well-being of farmers is influenced not only by the typical determinants of well-being that matter for non-farmers which include their personal relationships, their own health, and their social relationships, amongst others but also by what is happening on the farm.

The objectives of the study were to describe the socio-economic characteristics of the rice farmers in the study area, determine the food security and well-being status of rice farmers in the study area, determine the effect of climate change on food security and well-being status of rice farmers in the study area;

## **METHODOLOGY**

The study was conducted in Kebbi and Nasarawa States of Nigeria. Kebbi State lies at the extreme North West corner of Nigeria. The State covers a land area of about 37,697 square kilometres and the projected population of the state is 3.8 million persons at 2.5 percent annual growth rate (NPC, 2006; Kebbi State Government, 2015). The State lies within two ecological zones: Northern part which constitutes the Sudan Savannah and the Southern part that forms the Northern Guinea Savannah. These ecological zones favour diverse agricultural production opportunities of a wide range of arable crops, roots, tubers and livestock production.

### **Sampling techniques and sample size**

All the Agricultural zones in both Kebbi and Nasarawa States were considered for this study. The sampling procedure used to select the rice farmers for the study was Multi-stage. The first stage was a purposive selection of three Local Government Areas each from Kebbi and Nasarawa states due to their predominance in rice production thereby having a total number of six LGAs from the two States. The second stage was purposive selection of five villages from each of the six LGAs due to annual cases of flood and drought in addition to predominance cultivation of rice thereby having a total number of 30 villages in the study areas. The third stage was random selection of predominantly 361 rice farmers from all the villages which is ten percent of the total sample frame. This forms the total sample size for the research work. Data used for this study were obtained from primary sources. Primary data were collected



through administration of a well-structured questionnaires and interview Schedule. Both Descriptive (mean, percentages, frequency count,) and Inferential (Logit regression analysis) statistics were used to analyze the data collected.

### Food security status of rice farmers

The food security index was used to determine the food security status of each rice farmer based on the food security line using recommended daily calorie required approach.

Food security index (K) = Household daily per capital calorie consumed (X) / Household daily per capital calorie required (Y)

For a household to be food secure K must be greater than or equal to 1 ( $K \geq 1$ ). If K is less than 1 ( $K < 1$ ) the household is food insecure. Food recall consumption method was undertaken for each rice farmer's household and analyse each type of food mentioned for calorie content. The quantity of food consumed will be converted first to gram and further to calorie and will then be divided by the household size and by 7 days to obtain the calorie consumed per day per household using both the nutrient composition table of commonly eaten food in Nigeria and the adjustment table for adult equivalent using consumption factors for age-sex categories. The result was then compared with the required standard (2260 Kcal) respectively to determine the rice farmers' food security status. Researchers that have applied this method in Nigeria include among others Bayode, 2003; Babatunde; 2007 and Adebayo, 2010.

### Well-being status of rice farmers

In determining the well-being status of the respondents, the study adopted personal well-being index-Adult of the international well-being group (2013). The international well-being group categorizes personal well-being using a constructed well-being index-Adult scale. The scale is a number continuum in a linear scale that ranges between 0-10. The mean score of 5.5 will be considered with not satisfied=0 for score less than 5.5 and satisfied=1 for score greater than or equal to 5.5 from the list of various questions of satisfaction with specific life domains. The scale measures the degree of personal well-being satisfaction. The procedure that determines an individual well-being satisfaction depends on the individual responses to some structured survey questions. These questions are; standard of living, personal health, achievement in life, personal relationships, personal safety, community connectedness and future security which forms the seven life domains.

### Effect of climate change on food security status and well-being of rice farmers

The Logit regression model was estimated to determine the effect of climate change on food security status among rice farmers in the study area.

The Logit regression model is explicitly specified as;  
 $Y_i = b_0 + b_1X_1 + b_2 X_2 + b_3X_3 + b_4X_4 + b_5X_5 + b_6X_6 + b_7X_7 + b_8X_8 + U_i \dots (4)$

Where in the case of food security status;

$Y_i$  = Food security status ith rice farmer (1 = food secure, 0 = food insecure)

$X_1$  = Temperature (3 point scale)

$X_2$  = Erratic rainfall (yes or No)

$X_3$  = Sandstorms (number per month)

$X_4$  = Desertification per km (yes or No)

$X_5$  = Flooding (number)

$X_6$  = Drought (years of experience)

$X_7$  = Drying up of water bodies (Number)

$X_8$  = Revenue losses (Naira)

$U_i$  = Error term

Where in the case of personal well-being status;

$Y_i$  = personal well-being status ith rice farmer (1 = satisfied, 0 = not satisfied)

$X_1$  = Temperature (3 point scale)

$X_2$  = Erratic rainfall (yes or No)

$X_3$  = Sandstorms (number per month)

$X_4$  = Desertification per km (yes or No)

$X_5$  = Flooding (number)

$X_6$  = Drought (years of experience)

$X_7$  = Drying up of water bodies (Number)

$X_8$  = Revenue losses (Naira)

$U_i$  = Error term

## RESULTS AND DISCUSSION

### Socio-economic characteristics of the rice farmers

The result in Table1 showed that most of the respondents (77.3%) were at their productive age range of 21-50 years while 21.3% of the respondents were above 51 years. The mean age was 40.1 years, implying that rice production in the study area was dominated by young, middle age, active and energetic rice farmers that were receptive to innovations thereby improving their production capacity. This is in agreement with Agwu and Chukwu (2006) who reported that adoption of innovation is mainly associated with youthful and active age farmers than the older ones.

Table 1 also indicated that majority of the respondents (65.1%) had farming experience of more than 11 years. The mean years of farming experience was 25.6 years. Respondents with higher number of years in farming are likely to accept and adopt any strategy that will help them combat the effects of

climate change on rice production in the study area. This is in agreement with Adeniji (2002) and Okunade (2006) who reported that farmers with long period of farming experience would be conversant with constraints hindering productivity thereby easily accepting and practicing new ideas as means of overcoming their production constraints. The mean household size as indicated in table 1 was 8 people in the study area. This implies that the majority of the respondents in the study area had large house hold size of between 1-15 persons per house hold. To some extent family labour may not be a major problem since some family members will contribute to labour supply; this help in improving food production and achieving food security and well-being status. This finding is in agreement with those of Olanipekun and Kuponiyi (2009), who pointed out that large family, may serve as incentive for engaging in livelihood diversification in order to meet the obligation of the family. Table 1 as well showed the average farm size to be 1.9 ha per household in the study area. This implies the farmers have a relatively small farm size for their crop production.

#### **Food security and well-being status of rice farmers in the study area**

The result in Table 2 showed that 67.31% of the respondents were food secure and 32.69% were food insecure while it also indicated weighted mean of daily food calorie consumption for food secure households and food security index in the study areas as 2510.3 kcal and 1.11 respectively. Based on the recommended daily calorie intake of 2260 kcal, the average food secure household had 250.3 kcal in excess of the recommended daily intake in the study area. The average daily household per capita calorie food consumption for insecure household in the study area showed 1040.84kcal while the weighted mean of daily households' per capita calorie consumption for food insecure households had 1219.2 kcal below the recommended consumption of daily per capita calorie intake while their food insecurity index indicated 0.46 in the study area. The implication of this result is that larger number of farmers in the study area had in aggregate more than the daily calorie consumption requirements of food security status because more than average numbers of the respondents were food secure. These results collaborates with the findings of Adebayo (2010), which indicated that more than average numbers of respondents were food secure in the evaluation of UNDP microcredit scheme on food security status of farm household.

#### **Well-being status of farmers in the study area**

The result in Table 3 shows the well-being status of rice farmers in the study area using well-being

indicators and its measurements revealed that the respondents were satisfied with the following well-being status: standard of living ( $\bar{X}$  =5.94), health status ( $\bar{X}$  =6.79), life achievement ( $\bar{X}$  =5.42), personal relationship ( $\bar{X}$  =6.84), safety ( $\bar{X}$  =5.87) and feeling part of community ( $\bar{X}$  =7.54). The implication of this result is that the respondents in the study area were satisfied with the majority of the well-being indicators which were clearly above the well-being index satisfaction scale of 5.50 while indicators like life achievement ( $\bar{X}$  =5.42) and future security ( $\bar{X}$  =4.45) fell below the index satisfaction scale level. This further gives credence to the importance of improving farmers' well-being towards the growth of agricultural production.

#### **Effect of climate change on food security and well-being status of rice farmers**

The result in Table 4 showed that the model used was adequate and efficient in the explanation of the determinants of food security status of respondents. The Table indicated that out of 8 variables included in the model 4 had positive significant effect on the food security status of the respondents in the study area. The four variables which were temperature, desertification, drought and revenue losses had positive significance at 1%, 10%, 1% and 5% respectively. The implication of this result is that the higher the impact of these climate change variables on farming operation, the likely the effect on food security status challenge of the respondents in the study area.

The result of the logit regression was as well presented in Table 5. The Table showed a total of 8 variables out of which 3 included in the model were positively significant in the explanation of the variation in the well-being status of the respondents in the study area. The three variables which were temperature, sandstorm and desertification had positive significance effect at 1%, 5%, and 5% respectively. The implication of this result is that the higher the impact of these climate change element on farming operation, the likely the effect on well-being status challenge of the respondents in the study area.

#### **CONCLUSION AND RECOMMENDATIONS**

The study revealed the danger to sustainable achievement of food security and well-being status which were clearly shown by the result of the findings of the climatic elements representing the dimension of food security/insecurity and well-being status of farmers in the study area. In view of this extension services has to be entrenched as it directly affects farmers on how best to manage and adapt to



the adverse effect of climate change threatening their food security status and general well-being. It is recommended that emphasis on health education, general human hygiene, best agricultural climatic adaptation practices, health and safety management measures amongst others should be directed at farmers' households. This is to reduce the risk of consuming insufficient, unhygienic and unbalanced diets and possible general education at improving agricultural capacity, life goal achievements and investment in future security which could help increase farm size and food production thereby bringing about positive effects on farmers' food security and well-being.

Table 1: Distribution of respondents according to their socio-economic characteristics (n=361)

Socio-economic characteristics	Frequency	Percentages	Mean value
<b>Age (years)</b>			40.1
Less than 21	5	1.4	
21-30	99	27.4	
31-40	100	27.7	
41-50	80	22.2	
51-60	60	16.6	
Above 60	17	4.7	
<b>Marital status</b>			
Single	48	13.3	
Married	313	86.7	
<b>Education</b>			6.0
Non-formal	134	37.1	
Primary	97	26.9	
Secondary	66	18.3	
Tertiary	53	14.7	
Others (Quranic)	11	3.0	
<b>Household size</b>			8.3
Less than 6	99	27.4	
6-10	167	46.3	
11-15	71	19.7	
16-20	17	4.7	
Above 20	7	1.9	
81	45	12.5	25.6
<b>Farm Experience</b>			
1-5	57	15.8	
6-10	56	15.5	
11-15	49	13.6	
16-20	35	9.7	
21-25	38	10.5	
26-30	33	9.1	1.9
Above 31	81	22.4	
<b>Farm size (ha)</b>			
Less than 0.5	10	2.8	
0.5-1.0	77	21.3	
	2	0.6	

1.1-1.5	158	43.8
1.6-2.0		
2.1-2.5		
Above 2.5		

Source: Field Survey, 2018

Table 2: Distribution of respondents according to food security and food insecurity status in the study area (n=361)

Food security indices	Food secure	Food insecure	Total
<b>Distribution</b>			
Frequency	243	118	361
Percentage	67.31	32.69	100
<b>Calorie/day</b>			
Mean	2510.3	1040.8	
Gap/Excess	250.3	(1219.2)	
SD	686.9	284.8	
<b>Food sec. index</b>			
Mean	1.11	0.46	
SD	0.30	0.13	

Source: Field Survey, 2018

\*Recommended per capita calorie consumption is 2260 kilocalorie per day.

Table 3: Distribution of respondents according to their well-being status of in the study area (n=361)

Well-being indicators	Weighted Sum	Weighted mean	Remarks
Standard of living	2143	5.94	Satisfied
Health status	2452	6.79	Satisfied
Life achievement	1958	5.42	Not satisfied
Personal relationships	2469	6.84	Satisfied
Safety	2118	5.87	Satisfied
Feeling part of community	2722	7.54	Satisfied
Future security	1606	4.45	Not satisfied

Source: Field Survey, 2018



Table 4: Effect of climate change on food security status of respondents in the study area (n=361)

Variables	Co-efficient	Z-value	Decision rule
Temperature			S
Rainfall	1.1818	2.95***	NS
Sandstorm		0.17	NS
desertification	0.5147	1.13	S
Flood		1.94*	NS
Drought	0.1552	0.15	S
Drying of			NS
water bodies	0.6223	3.24***	S
Revenue		1.55	NS
losses	0.0188		
Constant		2.26**	
LR Chi <sup>2</sup> (8)	0.4698	1.43	
Prob> Chi <sup>2</sup>			
Pseudo R <sup>2</sup>	0.2681		

Source: Field Survey, 2018

\*\*\* Significant at 1% level, \*\* Significant at 5% level, \*Significant at 10% level.

\*S=Significant, NS=Not significant

Table 5: Effect of climate change on well-being status of respondents in the study area (n=361)

Variables	Co-efficient	Z-value	Decision rule
Temperature			S
Rainfall	1.2222	3.02***	NS
Sandstorm		0.03	S
desertification	0.0078		S
Flood		2.00**	NS
Drought	0.2922		NS
Drying of		2.47**	NS

water bodies	0.8098	0.16	NS
Revenue		1.45	NS
losses	0.0211	0.44	
Constant		1.60	
LR Chi <sup>2</sup> (8)	0.2188	1.38	
Prob> Chi <sup>2</sup>			
Pseudo R <sup>2</sup>	0.0675		
		1.59e-0	
		0.5388	
		66.01	
		0.0000	
		0.1333	

Source: Field Survey, 2018

\*\*\* Significant at 1% level, \*\* Significant at 5% level, \*Significant at 10% level.

\*S=Significant, NS=Not significant

## REFERENCES

- Adebayo, C.O. (2010). Evaluation of United Nations' Development Programme's Microcredit Scheme on the Food Security Status of Farm Households in Kaduna State, Nigeria. PhD Dissertation submitted to Ahmadu Bello University, Zaria. Pp 110.
- Adeniji, O.B. (2002). Adoption of improved technologies for cotton production by farmers in Katsina State, Nigeria. A Ph.D thesis submitted to Department of Agricultural Economics and Rural Sociology, Ahmadu Bello University, Zaria, Nigeria.
- Agwu, A.F. and Chukwu, P.C. (2006). Intra-household roles and constraints in rice cropping systems in Aninri Local Government Area of Enugu State, Nigeria. *International Journal of Agricultural and Rural Development*, 7, 1-9
- Babatunde, R.O., Omotesho, O.A. and Sholotan, O.S. (2007). Factors influencing food security status of rural farming Households in North Central Nigeria. *Agricultural Journal* 2 (3): 351-357, 2007
- Bayode, T. (2004). The Place of yam in Rural Household Food Security in Kogi State, Unpublished B. Agric Project submitted to Department of Agricultural and Farm Management. University of Ilorin.
- Berry, H.L., Hogan, A., Owen, J., Rickwood, D., Fragar, L., (2011). Climate change and farmers' mental health: risks and

responses. *Asia-Pacific Journal of Public Health* 23 (2), 119S–132S.

- Davies, A.E. (2009), “Food Security Initiatives in Nigeria: Prospects and Challenges”, Monograph, Department of Political Science, University of Ilorin, Nigeria.
- Durand, M. (2015). The OECD Better Life Initiative: How's Life? and the Measurement of Well-Being. *Review of Income and Wealth*, 61 (1), 4-17.
- Ekong, E.W. (2003). Group and non-group women farmers’ access to agricultural production responses in Akwa Ibom State, Nigeria. A Ph.D Thesis submitted to Department of Agricultural Extension and Rural Development, University of Ibadan, Ibadan, Oyo State.
- Helliwell, J. F., Layard, R., and Sachs, J. (2014). *World happiness report 2013*. Earth Institute, Columbia University.
- Keane J., Page S., Kergna A., Kennan J. (2009). An Overview of Expected Impacts, Adaptation and Mitigation Challenges, and Funding Requirements, Issue Brief No. 2, Overseas Development Institute.
- Okuneye, B. (2014). Climate Change, Food Security and Agriculture in Lagos State: The Challenges, Vulnerabilities, Adaptation and Mitigation  
<http://www.seap.moelagos.org/pool/climate>
- Olanipekun, A.A. and Kuponiyi, F.A. (2009). The condition of livelihood diversification to rural household welfare in Ogbomoso agricultural zone of Oyo State, Nigeria. *Nigerian Journal of Rural Sociology*, 11 (2): 18-26
- Schirmer, J., Berry, H.L., and O’Brien, L.V. (2013). Healthier land, healthier farmers: Considering the potential of natural resource management as a place-focused farmer health intervention. *Health and Place*, 24, 97-109
- Schmidhuber, J. and Tubiello, F. N. (2007). Global food security under climate change. *PNAS* 104 (50): 19703-08.
- World Health Organisation. (2013). Mental health: a state of well-being. World Health Organization, Geneva, Switzerland.  
URL:www.efdinitiative.org. Accessed on 2nd August, 2010.

# ANALYSIS OF THE DETERMINANTS OF PROFIT EFFICIENCY OF SMALL-SCALE MAIZE FARMERS IN SOME SELECTED LOCAL GOVERNMENT AREA OF OSUN STATE, NIGERIA

Ojo A.O., Akande, N.O. and Ojo, M.A

Federal University of Technology, Minna, Niger State  
Corresponding Author e-mail: [olanike.ojo@futminna.edu.ng](mailto:olanike.ojo@futminna.edu.ng)

## ABSTRACT

*The study was carried on the analysis of the determinants of profit efficiency of small scale maize farmers in some selected LGAs of Osun State. Primary data were used to elicit information from proportionately selected 220 farmers using well-structured interview schedules and questionnaire. Descriptive statistics and stochastic profit frontier were used to analyze the objectives of this study. The findings revealed that maize farming was dominated by male gender with mean age of 48 years. Most of them had cognate experience of about 19 years and married with a mean household size of 6. They had moderate literacy level but very low extension contact. The maize farmers earned about ₦29,057.63/month and so engaged in various off-farm income to augment the household income. The mean profit efficiency of 0.76 while 34% and 4% of the farmers belonged to the highest (0.81-0.90) and lowest (0.31-0.40) efficiency class index, respectively. The maximum likelihood estimates of the parameters of profit stochastic frontier model revealed that labour wage rate, cost of other farm inputs, prices of planting material, fertilizer, agrochemicals and farm were the main determinants of profit efficiency of the farmers. Profit inefficiency however increased with increase in age and off farm employment. The main constraints facing the farmers included inadequate extension and farm advisory services and, poor road access and transport facilities.*

**Keywords:** Efficiency, stochastic, production and farmers

## INTRODUCTION

All nations in the world and their occupancies depend on agriculture for their survival. Nigeria is an agrarian economy with agriculture contributing about 70% of the work force and providing employment for about 80% of the rural population (Central Bank of Nigeria (CBN), 2014 and Awoke, 2010). Though its present contribution to GDP (26.8%) is low yet the agricultural sector has the potential of improving the economy of the country if the resources are well harnessed.

Maize (*Zea mays*) is a staple and versatile crop grown across range of agro ecological zones; it covers nearly 17% of the estimated 200 million hectares cultivated land in sub-sahara Africa of which Nigeria is inclusive (FAOSTAT, 2015). The global production of maize is about 785 Million tonnes and Nigeria has been rated 10th largest producers of maize in the world and second largest producers in Africa with about 8 million tonnes of maize grain produced annually at average yield of 1.5 tonnes per hectare (FAOSTAT, 2015). In Nigeria, maize is mostly produced by small scale farmers and has gained prominence among cereal crops grown in the country because of its wide range of uses. First, maize is an important livestock feed and is also used industrially for starch and oil extraction. It is an important source of carbohydrate, protein, iron, vitamin B, and minerals in the diet. Its meal also is used as a replacement for wheat flour to make

cornbread and other baked products. It can be eaten as snack (pop-corn), boiled, roasted or cook with beans in the diet. Masa (cornmeal treated with lime water) is the main ingredient for tortillas, atole, and many other dishes of Mexican. Moreso, it can generate employment and income for both the rural and urban dwellers. Increased population growth and urbanization has however placed more demand on maize but the existing low level of efficiency in food grain, especially, maize production has resulted to low level of profit efficiency.

Profit efficiency in this study is defined as profit gain from operating on the profit frontier, taking into consideration farm-specific prices and factors. The physical productivity considerations are important improvement in production efficiency, but profit efficiency will lead to greater benefits to agricultural producers and its estimation will assist in firm level production specialization in the country (Ogundari, 2008 and Ali and Byerlee, 2000). Conversely, profit inefficiency is the profit loss from not operating on the profit frontier given farm specific price and resource base. The relationship between profit and error in the production decision is assumed to be translated into lower profits or revenue for the producer. As pointed out by Ogunniyi (2011), a profit function is much superior to production function because it permits straight forward derivation of own-price and cross-price elasticity, likewise output supply and input demand functions. Secondly, the



indirect elasticity estimates via profit function have distinct advantage of statistical consistency. Thirdly, it avoids problems of simultaneity bias because input prices are exogenously determined. Furthermore, problems of endogeneity can be avoided by estimating the profit or cost function instead of the production functions. It is against these backdrops that this research attempted to assess the performance of the maize farmers in the study area. Specifically, it aimed at examining the demographics of the maize farmers, analyze the determinants of profit efficiency of the farmers and identify the constraints facing smallholder maize farmers in the area.

## MATERIAL AND METHODS

### Study Area

The study was conducted in Osun State, Nigeria. The State is located in the south west zone of Nigeria, and lies between latitude  $7^{\circ}9'N$  and  $4^{\circ}6'E$  and between longitude  $7^{\circ}9'N$  and  $4^{\circ}6'E$ . The State is bounded in the north by Kwara State, in the east by Ekiti and Ondo State, in the south by Ogun State and in the west by Oyo State. The state covers land area of about  $9,251\text{km}^2$  the projected population stood at 3,423,535 with an annual growth rate of 2.45 percent (United Nations Population Fund (UNFPA), 2013). It has a bimodal pattern of rain fall with peak in June, July and September with a short break in August. The total rainfall ranges between 1000 mm and 1500 mm with daily temperature ranged between  $30^{\circ}\text{C}$  and  $35^{\circ}\text{C}$  while the mean daily minimum temperature ranged between  $17^{\circ}\text{C}$  and  $19^{\circ}\text{C}$ . The State consists of 30 Local Government Areas (LGAs) and has a considerable number of highly urbanized towns namely: Ile-Ife, Ikirun, Ilobu, Iwo, Ede, Ila-Orangun and Ikire. The predominant language is Yoruba while the major economic activities of the inhabitants are farming. The main crops grown in the State are: maize, cocoa, yam and tomatoes. The major livestock kept are poultry (Broilers, layers and turkey), goats and pigs. The farmers use simple farming tools such as hoes, cutlass and sickles among others, for their farming operations.

### Sampling Technique

The respondents for this study were selected using multistage sampling procedure. Osun State has three agricultural zones namely, zone I, zone II and zone III. The first stage involved the random selection of one LGA from each of the zones. The second stage

involved random selection of three towns/villages from each of the LGAs selected while at the third stage, out of six hundred and twenty of the total registered maize farmers in the study area, 43% of the maize farmers were selected on the basis of their high level of maize production in proportion to the total population of maize farmers in each of the LGA making a total of 220 respondents in the study area.

### Method of Data Collection

The data used for this study were obtained from primary sources. The data were collected with the aid of structured interview schedules with the assistance of trained enumerators. Data were collected on farmers' characteristics such as age, sex and marital status; production factors such as farm size, agrochemicals and planting materials and, institutional factors such as extension contact, source of farm labour and source of capital.

### Analytical Techniques

The analytical tools such as descriptive statistics and stochastic profit frontier were used to analyze the objectives of this study.

According to Ali and Byerlee (2000) profit efficiency within a profit function context is defined as the ability of a farm to achieve the highest possible profit, given the prices and levels of fixed factors on the farm. Profit inefficiency is defined as profit loss from not operating on the profit frontier given farm specific price and resource base. Profit is maximized where marginal value product equals marginal cost (economic efficiency condition)

Total profit is realized by subtracting total cost from total revenue

$$\Pi = TR - TC \quad (1)$$

Where,  $\Pi$  = Profit, TR = Total revenue and TC = Total cost

Following Ogundari (2006) and Rahman (2002), the actual normalized profit function was derived as follows:

$$\Pi = \sum (TR - TC) = \sum (P_y Q - W_i X_i) \quad (2)$$

To normalize the profit function, gross margin ( $\Pi$ ) is divided on both sides of the equation above by  $P_y$  which is the market price of 1kg of maize output.

That is:

$$\frac{\Pi(p, z)}{P_y} = \frac{\sum (P_y Q - W_i X_i)}{P_y} = Q - \frac{W_i X_i}{P_y} = f(X_i, Z_i) - \sum (p_i$$

Where: TR = Total revenue, TC = Total cost,  $W_i$  = Price of variable input,  $Z_i$  = Quantity of optimized input,  $X_i$  = Price of fixed inputs, Q = Output,  $P_y$  =



51 – 60	76	34.66	
> 60	7	3.18	
<b>Sex</b>			
Female	96	43.63	
Male	124	56.36	
<b>Marital Status</b>			
Married	178	80.90	
Widowed	21	9.54	
Divorced	21	9.54	
<b>Household size</b>			6.00
1 – 5	66	30.00	
6 – 10	152	69.09	
> 10	2	0.91	
<b>Farming experience</b>			19.00
1 – 10	20	9.09	
11 – 20	128	58.18	
21 – 30	62	28.18	
> 30	10	4.54	
<b>Educational status</b>			
Non-formal education	22	10.00	
Primary	108	49.09	
Secondary	67	30.45	
Post-secondary	23	10.45	
<b>Farm size</b>			1.25
0.01 – 1.00	145	65.90	
1.01 – 2.00	43	19.95	
2.01 – 3.00	8	3.63	
3.01 – 4.00	13	5.90	
4.01 – 5.00	5	2.27	
Above 5.00	6	2.27	
<b>Extension visit</b>			
No	176	80.00	
Yes	44	20.00	
<b>Engagement in other occupation</b>			
No	110	50.00	
Yes	110	50.00	
<b>Monthly income</b>			29,057.63
≤ 25,000	154	70.00	
25,001 – 50,000	26	11.81	
50,001 – 75,000	24	11.90	
75,001 – 100,000	6	2.18	
> 100,000	7	3.18	
<b>Credit access</b>			
No	131	59.54	
Yes	89	40.45	

Source: Field Survey, 2017

The findings also revealed that majority, *that is*, 80.9% of the farmers were married. Others were either widowed or divorced. Since the larger percentage of the farmers were married, the household size of the farmers would probably increase and thereby enhancing the provision of cheap source of labour towards efficiency in maize production in the area. This finding is similar to that

of Adewumi (2017) on optimum production plans for cassava- based crop farmers in Kwara State who reported that 81.10% of farmers in Kwara State were married.

The result of the household size of the farmers in the area showed that an average maize farmer had household size of six people with most having household size of 6 – 10 persons. The household size



is important as it could determine the level of family labour available for farming activities thereby reducing the labour cost of the farmers. If majority of the households were in their economically active age and were also willing to actively participate in maize production, it could enhance maize profit efficiency in the area. However, farmers who did not have very large household size could have augmented their farm operations with hired labour.

Farming experience refers to the number of years spent in farming activities. It can greatly influence the efficiency of production of farmers. The result in Table 1 revealed that an average maize farmer in the area had 19 years of farming experience. About three-fifth (58.18%) of them had experience of 11 – 30 years while only 9.09% of the farmers had 1-10 years of farming experience. The finding implied that most of the farmers might have developed practical skills in maize production. This could assist them reduced pre and post-harvest losses through timely farm operations, weed control and diseases prevention measures so as to boost the output of the farmers. This findings was slightly higher than the 7 years and 15 years reported by Aminu *et al.* (2013) on effect of technical efficiency on dry season vegetable farms and Adewumi (2017) on optimum production plans for cassava- based crop farmers in Kwara State, Nigeria) for farmers in Lagos and Kwara States, respectively.

Majority of the farmers had at least primary education as only 10% of them did not have any form of formal education. It was observed that most of them had one form of formal education or the other from primary level (49.09%) to secondary (30.45) and post-secondary level (10.45). Hence, the literacy level of farm households in the study area was relatively moderate. Formal education is a vital variable that could enhance the chances of farmers in accepting modern ways of agricultural production especially those that will enhance efficiency in maize production in the area.

The result in Table 1 further revealed that a larger proportion of the farmers (65.90%) had farm size of between 0.01 and 1.00 hectares while 19.95% have farm size of between 1.01 and 2.00 hectares. Only 2.27% interestingly cultivate above 5 hectares of farmland. The mean farm size in the area was found to be 1.25 hectares. This figure is far lower than the 3.88 hectares reported by Ogunniyi (2011) in a study on profit efficiency among maize farmers in Oyo State, Nigeria. This indicated that majority of the maize farmers in the study area had small-farm holdings and the implication is that small farm

holdings results in small farm production and consequently, little farm output. The size of farm land available to farmers is vital to attaining efficiency in maize production.

The result presented in Table 1 showed that only 20.09% of the farmers had extension services delivered to them by the extension agents in the area. This is an indication that majority of the farmers lacked access to adequate extension service delivery which could help facilitate the adoption of latest agricultural innovations and technologies such as improved seed and fertilizer. This could go a long way to enhance efficiency in maize production by the farmers in the area.

About half of the farmers engaged in off-farm occupations (Table 1) so as to augment their farming activities. This served as security against risk embedded in maize production. Besides, it could also increase their earnings to meet up with household expenditure and farming expenses such as purchase of farm inputs that will enhance efficient maize production. This finding lends credence to the assertion of Sallawu (2014) in a study conducted on livelihood and income diversification strategies among farm households in Niger State, Nigeria. It was reported that farming households normally engage in various off-farm activities that will enhance their livelihood.

The distribution of farmers according to the monthly income presented in Table 1 revealed that an average farmer in the area earned ₦29,057.63 monthly. It showed that majority (70.0%) of them earned a maximum of ₦25,000 monthly. Moreover, 11.81% earned ₦25,001-₦50,000 while only 3.18% earned above ₦100,000 monthly. This is a clear indication that the farmers were low income earners. Low income may prevent the farmers from purchasing the inputs needed for efficient production at the right time and at the right quantity.

Access to agricultural credit enables farm households to procure additional production inputs such as fertilizers, agrochemicals and to hire additional labour so as to expand production and produce efficiently. The result shown in Table 1 revealed that most (59.54%) of the farmers in the study area had no access to credit. This finding is in agreement with the findings of Jirgi (2013) in a research conducted on technical efficiency and risk preferences of cropping system in Kebbi State, Nigeria; Sallawu (2014) on livelihood and income diversification strategies among farm households in Niger State, Nigeria and, Adewumi (2017) who reported that majority of farm

households in Kebbi, Niger and Kwara States respectively did not have access to agricultural credit.

### Profit Efficiency of the Maize Farmers

Profit efficiency in this study is defined as profit gain from operating on the profit frontier, taking into consideration farm-specific prices and factors (Ogundari, 2008). The summary statistics of prices of inputs used by maize farmers were presented in Table 2.

#### Summary statistics of prices of inputs (per hectare) in the profit efficiency model

The findings revealed that, on the average per hectare, the sampled maize farmers paid ₦649.55 per man-day to hired labour with minimum of ₦500.00 and maximum of ₦1000.00 respectively. Also, the farmers spent ₦949.55 on maize seed planted measured in kilogramme with minimum of ₦950.00

and maximum of ₦1100.00. More so, the maize farmer spent ₦6500 on a bag of fertilizer with minimum of ₦5500 and maximum of ₦7500 respectively. A total of ₦1187.05 was spent on a litre of agrochemical with minimum of ₦11000.00 and maximum of ₦1400.00. Lastly, the maize farmers spent ₦1174.78 on other farm inputs with the minimum of ₦425.00 and maximum of ₦650.00.

#### Profit efficiency scores of the maizefarmers in the study area

The scores in Table3 showed that the mean profit efficiency of the sampled maize farmers in the study area was 0.76. This implied that on the average farmers in the study area were able to obtain a 76% of maize profit from a given mix of production inputs and corresponding output. The highest efficiency class index was between 0.81-0.90 of 34.09% while the minimum index was between 0.31-0.40 of 4.09%. However, 69.54% operated

**Table 2: Summary statistics of prices of inputs (per hectare) in the profit efficiency model**

Variable	Mean	Standard Deviation	Minimum	Maximum
Labour wage rate(₦/man-day)	649.55	125.10	500.00	1000.00
Average price of panting material(₦/kg/)	964.06	23.98	950.00	1100.00
Average price of fertilizer(₦/bag)	6500.00	433.01	5500.00	7500.00
Average price of agrochemicals(₦/litre)	1187.05	82.90	1100.00	1400.00
Cost of other farm inputs(₦/ha)	1774.78	716.60	425.00	650.00

Source: Field Survey, 2017

**Table 3: Profit efficiency scores of the maizefarmers in the study area**

Efficiency class score	Frequency	Percentage
0.31 - 0.40	9	4.09
0.41 - 0.50	13	5.90
0.51 - 0.60	23	10.45
0.61 - 0.70	21	9.54
0.71 - 0.80	42	19.09
0.81 - 0.90	75	34.09
0.91 – 1.00	37	16.81
<b>Total</b>	<b>220</b>	<b>100.00</b>

Mean	0.7575
Minimum	0.3116
Maximum	0.9549

Source: Field Survey, 2017

between 0.71-1.00. The maximum profit efficiency index was 0.95 (*That is*, 95%) while the minimum profit efficiency index of farmer was 0.31 (*That is*, 31%). This finding is lower than the mean profit efficiency of 0.87 reported by Aminu (2013) for *maize* farmers in Northern Nigeria. From the results obtained, farmers in Osun State were generally relatively efficient, they still have room to increase the profit efficiency as about 24.25% efficiency gap from optimum (100%) was yet to be attained by all farmers. Thus, in short run there is a scope for increasing profit in maize production by 4.51% through adopting the technology for best practice in maize farming in the study area.

**Maximum likelihood estimates of parameters of stochastic profit frontier model**

The maximum likelihood estimates of the parameters of profit stochastic frontier model were as presented in Table 4. Estimates of the parameters of the stochastic frontier production model revealed that apart from labour wage rate and cost of other farm inputs, all the estimated coefficients of the variables of the profit function were positive. The coefficient of labour wage rate was negative but significant at  $P < 0.05$  probability level. This implied that a unit increase in labour wage rate likely reduced the profit of the farmers by 0.03679. Conversely, the coefficients of the prices of planting material, fertilizer, agrochemicals and farm size were positive and significant at  $P < 0.01$ ,  $P < 0.10$ ,  $P < 0.10$  and  $P < 0.01$ , respectively. This implied that the farm level profit of the maize farmers in Osun State increased with increase in these variables, *that is*, a unit increase in these variables led to increase in the profit of the farmers by 0.08063, 0.02752, 0.06590 and 0.83560 respectively. This finding conforms to that of Ojo *et al.* (2009) on profit efficiency of small scale cowpea farmers in Niger State and Abdullahi (2015) in a study conducted on the profit efficiency of small scale rice farmers in Bida Local Government Area of Niger State, Nigeria. It was reported that farm size and labour wage rate had negative effect on profit efficiency of the farmer while prices of seed, fertilizer and agrochemicals had positive effect on profit efficiency of the farmers.

The estimate of the sigma-square (0.65294) was significantly different from zero at  $P < 0.01$  which attested to the goodness of fit of the model. The estimated gamma (0.99259) was also significant at  $P < 0.05$  which implied that 99.26% variation in profit accrued from maize was due to the profit inefficiencies of the farmers in the area. The inefficiency model indicated that the age of the farmer and off-farm employments were positive and significant at  $P < 0.05$  and  $P < 0.10$ , respectively. This implied that profit inefficiency of the maize farmers likely increased with increase in these variables. This therefore means that age and off-farm employment had negative effect on the profit efficiency of the farmers in maize production. This finding corroborates that of Abdullahi (2015) for rice farmers in Niger State. Furthermore, the result revealed that farmers' educational level, farming experience, extension contact and amount of credit accessed were negative and significant at  $P < 0.05$ ,  $P < 0.10$ ,  $P < 0.05$  and  $P < 0.10$ , respectively. This means that an increase in these variables likely reduced the profit inefficiency of the maize farmers in the area. Increase in amount of credit accessed will enhance the acquisition additional production inputs required for production expansion; more years of farming experience means more perfection in application of skills and allocation of scarce resources while more educational attainment and extension contact implied more enlightenment on best farming practices that could positively influence the profit efficiency of the farmers in the area. This finding is similar to those of Ojo *et al.* (2009) on profit efficiency of small scale cowpea farmers in Niger State, Ogunniyi (2011) on determinant of profit efficiency among small sale maize farmers in Nigeria, Oladebo (2012). Profit efficiency among cassava producers: Empirical evidence from South western Nigeria, Oluwaranti (2012) Estimation of Farm efficiency using Cobb – Douglas, and Abdulai (2015) Profit efficiency of rice farmers in Niger State and Ogunniyi (2011) Profit efficiency among maize producers in Oyo State, Nigeria.

**Table 4: Maximum likelihood estimates of factors affecting the profit efficiency of maize farmers in Osun State**



Variable	Coefficient	T-ratio
<b>Efficiency model</b>		
Labour wage rate	-0.03679	-2.42**
Average price of planting material	0.08063	2.89***
Average price of fertilizer	0.02752	1.80*
Average price of agrochemicals	0.06590	1.85*
Farm size (Ha)	0.83560	4.94***
Cost of other farm inputs	-0.00997	-1.24
<b>Inefficiency model</b>		
Age	0.12331	2.03**
Educational level	-0.04379	-2.17**
Household size	-0.25129	-1.55
Farming experience	-0.01907	-1.75*
Off-farm employment	0.14425	1.94*
Extension contact	-0.25868	-2.05**
Amount of credit accessed	-0.00003	-1.85*
Distance to market	0.12794	1.24
Sigma-squared	0.65294	9.19**
Gamma	0.99259	3.06***
Log likelihood function	-52.27137	
LR test	101.43935	

**Note:** \*\*\* = P<0.01; \*\* = P<0.05 and \* = P<0.10 probability level

**Source:** Field Survey, 2017

### Constraints Faced by the Maize Farmers in Osun State

The result of analysis of the constraints faced by the maize farmers in Osun State was presented in Table 5. The result showed that inadequate extension and farm advisory services with weighted mean of 4.77 ranked first. They lacked the proper link to government and research institutes as a result of inadequacy in the number of well-equipped extension personnel that should foster appropriate service delivery to the farmers. This was corroborated by the argument of Ezeh *et al.* (2010) on the determinant of technical efficiency in arable crops production and the policy implications in Imo State, Nigeria. It was reported that inadequate transfer of information to farmers by extension agents due to bottlenecks such as negative attitudes of extension agents to their work could lead to poor service delivery. This finding is also similar to that of Pelemo (2016) who carried out a research on the effect of cashew production on rural poverty alleviation in Kogi State, Nigeria. This constraint was closely followed by lack of access to good road and transport facilities with a mean score

of 4.64. Lack of access to road and transport facilities could hinder the smooth movement of farm produce to the market. The implication of this was that, farmers may find it difficult to sell their produce in good time. This finding agreed with the study conducted by Abu (2013) and Kimiri *et al.* (2013) on profit efficiency among sesame farmers in Nassarawa State and, Boniface *et al.* (2014) on the analysis of factors affecting small-holder rice farmers' level scale of production and market participation in Tanzania who reported that good transport networks in areas of production increases market access as it enhances free and easy movement of products. Moreover, the high cost of farm inputs which ranked 3rd was also a major constraint faced by the farmers which is a barrier to farmers' timely farm operations which could also significantly affect efficient maize production in the area. This result conformed to the findings of Adewumi (2017) in a study on the optimum production plans for cassava-based crop farmers in Kwara State. The research result showed that high cost of farm inputs was a major constraint in the area. High incidence of pest and diseases was

also a severe constraint in the study area. It reduced both the quantity and market value of the maize produce. This is not only a threat to efficient maize production in the area, but of greater threat to food security in the area and Nigeria as a whole. Result in the Table further revealed lack of market information as a severe constraint faced by the maize farmers. Market information enables smallholder farmers to make proper decisions about input and output prices for their produce. Therefore whenever there is scarcity of market information, middlemen tend to act based on the farmers ignorance as opined by Varathan, *et al.* (2012) and Mohanasundaram (2015) in a finding on Production and marketing constraints in dairy cattle rearing. Inadequate storage facilities ranked sixth constraint with a mean score of 3.83. Farmers experience a lot of wastages, reduced income and profit, from maize production due to inadequate storage facilities to hold stock so as to

balance up excess and shortfall in supply during glut and off season, respectively. The constraint implied persistent poor prices during glut and shortfall in market supply as argued by Varathan, *et al.* (2012), Abu (2013) and Kimiri *et al.* (2013) in a finding on Profit efficiency among sesame farmers in Nassarawa. Furthermore, lack of farmers' association/cooperative society in the study area as revealed from the result in Table 5. The implication of this was that, their possibility of gaining access to agricultural credit facilities and other agricultural incentives would be minimal.

The result further revealed that conflict with Fulani herdsmen, insufficient rainfall, limited farmland and pilfering/theft however were not severe constraints faced by the maize farmers in the study area. Generally, maize farmers in Osun State were faced with several challenges which require attention for improved and efficient maize production.



**Table 5: Constraints Faced by the Maize-Based Crop Farmers**

Constraint	Weightedsum	Weightedmean	Rank	Remark
Inadequate extension and farm advisory services	1069	4.77	1 <sup>st</sup>	Severe
Poor road access and transport facilities	1039	4.64	2 <sup>nd</sup>	Severe
High cost of farm inputs	993	4.43	3 <sup>rd</sup>	Severe
High incidence of pests and diseases	939	4.19	4 <sup>th</sup>	Severe
Inadequate market information	893	3.99	5 <sup>th</sup>	Severe
Inadequate storage facilities	857	3.83	6 <sup>th</sup>	Severe
No co-operative or farm association	756	3.38	7 <sup>th</sup>	Severe
Conflict with Fulani herdsmen	663	2.96	8 <sup>th</sup>	Not severe
Insufficient rainfall	630	2.81	9 <sup>th</sup>	Not severe
Limited farm land	583	2.60	10 <sup>th</sup>	Not severe
Pilfering/ theft	462	2.06	11 <sup>th</sup>	Not severe

Source: Field Survey, 2017

### CONCLUSION AND RECOMMENDATIONS

It could be concluded from the findings of this research that maize farming was dominated by male gender with mean age of 48 years. Most of them had cognate experience of about 19 years and married with a mean household size of 6. They had moderate literacy level but very low extension contact. The profit efficiency analysis revealed that maize farmers were operating below the frontier level and its main determinants included labour wage rate, cost of other farm inputs, prices of planting material, fertilizer, agrochemicals and farm size. Profit inefficiency increased with increase in age and off farm employment while

increase in farmers' educational level, farming experience, extension contact and amount of credit accessed reduced the profit inefficiency of the maize farmers. The main constraints facing the farmers included inadequate extension and farm advisory services, poor road access and transport facilities and high cost of inputs. It is therefore recommended that youth with high literacy profile should be encouraged to engage in maize production. Also, extension agents should intensify their contacts with the maize farmers periodically. Federal government should subsidize the cost of inputs to make them affordable for the farmers.

### REFERENCES

- Abdulai, A., & Huffman, W. (2000). Structural adjustment and economic efficiency of Rice farm Farmers in Northern Ghana. Economic Development and Cultural Change. Hand book on Rice production (504-519).Ghana, Golden press.
- Adenegan, K.O., Adams, O and Nwauwa, L.O.E (2013) Gender Impact of Small-Scale Farm Households on Agricultural Commercialization in Oyo State, Nigeria. *British Journal of Economics, Management and Trade* 3(11), 1-11.
- Adewumi, A. (2017). Optimum production plans for cassava-based crop farmers in Kwara State, Nigeria. Unpublished MTech Thesis, Department of Agricultural Economics and Extension Technology, Federal University of Technology, Minna Nigeria.
- Akinbode, S.O. Dipeola A.O & Ibrahim D.A.(2011). Effects of Disease Burden on Technical Efficiency among low land Rice Farming household in North central Nigeria. *World Journal of Agricultural science* 7(5) 359-369.
- Ali, M. and Byerlee, D. (2000). Economic and profit Efficiencies of small farmers in changing world: *Journal of Development studies*, 4: 1-27
- Aminu, O.J. & Ali, M.(2013). Analysis of effect of Ill- health on technical efficiency of maize Farmers in Northern region of Nigeria. *Journal of Agricultural Economics* 2(1), 3-9.
- Awoke, M.U. (2010): Resource use efficiency in multiple cropping system by Small holder Farmers in Ebonyi State. Ph.D. Dissertation Department of Agricultural Economics



- and Extension, ESUT, Enugu, Enugu Stae. 54-76pp.
- Boniface, N.S., Fengying N & Fang C. (2014). An analysis of factors affecting smallholder rice farmers' level of sales and market participation in Tanzania; Evidence from National Panel Survey Data 2010 -2011. *Journal of Economics and Sustainable Development* 5(23), 185-206
- Central Bank of Nigeria (CBN) (2014). Agricultural sector aids in boosting Nigeria domestic product. *Statistical Bulletin*, 10: 23- 25.
- Coelli, T. J. (1995). Recent Development in Frontier Modeling and Efficiency Measurement *Journal on Econometric*, 219-245.
- Coelli, T. J. (1996). A Guide to Frontier version 4.1C: A computer programme for Stochastic Frontier production and cost function Estimation. Mines, Department of Econometrics, Armidele, Australia: University of New England.
- Chukwuji, C. O., Inoni O. E. & IkeP. C., (2007). Determinants of technical efficiency in gari processing in Delta State Nigeria. *Journal of Central European Agriculture*, 8(3), 327-336
- Ezeh C. I., Akpa C. E., Okudu P. O. (2010). Determinants of technical efficiency in arable crops production and policy implications in Imo state, Nigeria. *Advances in Agriculture Botantics-International Journal of Bioflux Society*, 2(3), 239-246.
- International Institute of Tropical Agriculture (2015). Classification of Maize based on (texture, colour and shapes) Discussion paper (5-10).
- Jirgi, A. J. (2013). Technical efficiency and risk preferences of cropping systems in Kebbi State, Nigeria. Unpublished PhD Dissertation, Department of Agricultural Economics, University of Free State, Bloemfontein, South Africa
- Kirimi, L., Gitau, R. & Olunga, M. (2013). Household food security and commercialization among smallholder farmers in Kenya. *4th International Conference of the African Association of Agricultural Economists*. Nairobi, Kenya: Tegemeo Institute of Agricultural Policy and Development, Egerton University.
- Mohanasundaram, P. (2015). Cultivation of Cotton: A Study on Factors and Problems. *International Journal of Arts, Humanities and Management Studies*, 1(3), 1-6
- Ogundari, K. (2006). Determinants of profit efficiency among small scale rice farmers in Nigeria. A profit function approach. *Research Journal of Applied Sciences*, 1:116-121.
- Ogunniyi, L. T. (2008). Profit efficiency among cocoyam producers in Osun state, Nigeria. *International Journal of Agricultural Economics Rural Development*, 1(1),38-46.
- Ogunniyi, L.T (2011) Determinant of profit of among small scale maize farmers in Nigeria *Research Journal of Applied Science* 1(2),116-122
- Ojo, M. A., Mohammed, U. S., Ojo, A. O., Yisa, E. S. & Tsado J. H. (2009). Profit efficiency of small scale cowpea farmers in Niger state, Nigeria. *International Journal of Agricultural Economics and Rural Development*, 2(2), 40-48.
- Oladeebo, J.O & Oluwaranti, A.S. (2014). Profit efficiency among cassava producers: Empirical evidence from South western Nigeria. *Journal of Agricultural Economics and Development*, 1(2), 46-52.
- Oluwaranti, A.o. & Oladeebo, O. (2012). Estimation of Farm efficiency using Cobb – Douglas Function. *Research Journal of Econometrics* 1(1) :12-16
- Pelemo, J. J. (2016). Effect of cashew production on rural poverty alleviation in Kogi State Nigeria. Unpublished MTech Thesis, Department of Agricultural Economics and Extension Technology Federal University of Technology, Minna, Nigeria.
- Sallawu, H. (2014). Livelihood and income diversification strategies among farm households in Niger State, Nigeria. Unpublished MTech Thesis, Department of Agricultural Economics and Extension Technology Federal University of Technology, Minna, Nigeria
- Varathan, B.J., Prabu, M. A., Pandian, A., Kumar, G.S. & Selva K.N. (2012). Production and marketing constraints in dairy cattle rearing as perceived by women self-help

group members and non-members.  
*Journal of Veterinary and Animal  
Sciences*, 8(2), 68-71



# SILAGE QUALITY AND PROXIMATE COMPOSITION OF *PANICUM MAXIMUM* (GUINEA GRASS) ENSILED WITH GRADED LEVELS OF HONEYCOMB WASTE

Bamigboye<sup>1\*</sup>, F. O., T. A. Ogunnusi<sup>2</sup>

<sup>1</sup>Department of Agricultural Sciences, Afe Babalola University, Ado Ekiti, Nigeria

<sup>2</sup>Department of Biological Sciences, Afe Babalola University, Ado Ekiti, Nigeria

\*Corresponding Author's E-mail: [bamigboyefo@abuad.edu.ng](mailto:bamigboyefo@abuad.edu.ng) GSM: 07066622836

## ABSTRACT

Silage additives most especially molasses are essential in making good quality silage but are expensive and not available to farmers in Nigeria. The present study was conducted to evaluate the effects of using graded levels of Honeycomb waste (HCW) as an additive in Guinea grass (GG) (*Panicum maximum*) silage. Silage quality and proximate composition of ensiled Guinea grass with graded levels of honeycomb waste were assessed using standard methods. The additive was thus graded: 5, 10 and 15 %. Significant differences ( $P < 0.05$ ) existed in all the parameters considered. The results showed that dry matter ranged from 83.2 % in GG + HCW 5 % to 84.43 % in GG + HCW 15%, temperature: 25.5 – 26.67 °C (GG + HCW 15% and GG + HCW 5% respectively) and pH: 5.18 – 5.51 (GG + HCW 10% and GG + HCW 15% respectively). All the silages were firm in texture, of pleasant smell and olive green in colour. The crude protein ranged between 7.13% in GG + HCW 5 % and 8.23 % in GG + HCW 15 %. The study showed that silage qualities, CP, ash, CF and NFE nutrients were enhanced as the HCW level increased in Guinea grass silage. However, 15 % level seemed to be the best.

**KEYWORDS:** Silage quality, Guinea grass, proximate composition, silage making and Honeycomb waste

## INTRODUCTION

Scarcity of quality forage all-year round is still a challenge in ruminant nutrition especially, small ruminants. In Nigeria, the dry season is characterised by little or no rainfall at all. Hence, green forages are scarce during these periods. Since small ruminants are mostly reared by farmers in small numbers, they hardly established grazing yards for their animals. The grazing yards can be fertilized and irrigated to supply water all-year round and subsequently; green forages.

*Panicum maximum* (Guinea grass) is one of the most common and wide spread grasses in the derived savannah region of Nigeria. Guinea grass is tolerant of shade and fire, but susceptible to water logging or severe drought. Under good conditions, its nutritional value is high, having up to 12.5 % crude protein, total digestible nutrients (TDN) of 10.2 % and calcium, phosphorus and magnesium (Agishi, 1985; McDonald *et al.*, 1988). Aderinola *et al.* (2014) affirmed that *P. maximum* has been classified among the best forage grass due to its high nutritive value. Also, *P. maximum* produces high yield of palatable fodder and is suited for grazing, but rapidly declines in nutritive value with age and could also die off if continually grazed close to the ground. Also, Guinea grass like any other tropical grass rapidly declines in crude protein and soluble carbohydrate as maturity

sets in. It increases in crude fibre and lignin which leads to reduction in voluntary intake and digestibility (Agishi, 1985). Bamikole and Babayemi (2004) stated that although ruminants relish *P. maximum*, this grass becomes scarce during the dry season. Also, during the rainy season, if not harvested, processed and preserved, the grass becomes fibrous and less nutritive. This results into loss of valuable feed resource that could have been used in ruminant production. Guinea grass is available in almost all ecological zones in Nigeria but scarce in dry season, suggesting the need for conservation (Familade and Babayemi, 2009).

This scenario has led to forage preservation to overcome dearth. Silage production in the tropics is a sustainable means of supplementing feed for ruminants in the dry season (Babayemi and Igbekoyi, 2008). Silage making; a preservative method, involves the use of additive that enhances the rapid growth of lactic acid bacteria at the detriment of spoilage bacteria. The lactic acid bacteria are responsible for pH reduction in silage and it is paramount in silage making. The main objective of applying additives, such as glucose and urea, in ensiling is to reduce pH more rapidly so as to preserve carbohydrates and proteins and inhibit the growth of microorganisms that might deteriorate the



quality of the silage (Weinberg and Muck, 1996; Zhang *et al.*, 2000). Molasses is one of the commonly used additives in silage making. However, in Nigeria, molasses is quite expensive and inaccessible most times especially to smallholder farmers. Hence, the need for a substitute; apiarian farming is getting populous in Nigeria. Honey is extracted from the beehive/honeycomb and honey-comb waste is the left-over of this extraction. Due to the fact that the honey-comb waste still has some quantity of honey, it was therefore used to make silage in the present study.

## METHODOLOGY

### Description of the study area

Afe Babalola University is located in Ado Ekiti, Nigeria. Ado Ekiti is a city in southwest Nigeria, the state capital and headquarters of the Ekiti State. It is also known as Ado. The people of Ado Ekiti are mainly of the Ekiti sub-ethnic group of the Yoruba. Ado-Ekiti is mainly an upland zone, rising over 250 m above sea level. Ekiti State lies between longitude 5°13'17 East of Greenwich meridian and latitude 7°37'16 North of the Equator. The weather condition of the study area is tropical climate with temperature of about 26 °C, humidity 74 %, Rainfall 300-1100 mm.

### Sample collection and Silage making

Guinea grass was harvested from natural grassland in Afe Babalola University Ado Ekiti. The grass was harvested in June (June peak of rainy season). The harvested grass was chopped to smaller size (about 5cm) and wilted under shade to reduce the moisture level. Thick polythene bags (double) were used as mini-silo for the fermentation of the grass. The wilted grass was packed and compressed to eliminate air. It was packed in layers into the mini-silo with honeycomb waste added as additive on each layer. The honeycomb waste was added in graded levels: 5 %, 10 % and 15 %. The final compaction was done; the polythene was tied and made airtight.

GG + HCW 5 % = Guinea grass ensiled with 5% Honeycomb waste

GG + HCW 10 % = Guinea grass ensiled with 10 % Honeycomb waste

GG + HCW 15% = Guinea grass ensiled with 15 % Honeycomb waste

The ensiling was carried out for 15 days (Ogunjobi *et al.*, 2010) in triplicate with each weighing 1kg. On termination, the silages were opened and assessed for physical qualities and proximate composition.

### Physicochemical Characteristics of Silage

The assessed qualities were dry matter, temperature, pH, colour, smell and texture according to Babayemi and Igbekoyi (2008). Immediately the silage was opened, a laboratory thermometer was inserted to determine the temperature. Sub-samples from different points and depths were then taken and mixed together for dry matter determination by oven drying at 105°C to a constant weight. Oven dried samples were milled (2 mm sieve) and kept in an airtight containers for proximate analysis. The pH of silage was done by soaking 100 g in a beaker containing 100 ml of distilled water. The supernatant liquid was decanted and pH meter was used to determine the level of the pH. Colour assessment was ascertained using visual observation with the aids of colour charts. The odour or smell of the silage was relatively assessed as to whether bad, pleasant or fruity. Structure of the silage was also determined based on firmness or otherwise.

### Proximate analysis

Crude protein, crude fiber, ether extract and ash contents of silages were determined according to AOAC (2000). Kjeldahl procedure was used to determine the total nitrogen present in the samples. It was effected through the breaking down of 2g sample in 25 ml concentrated H<sub>2</sub>SO<sub>4</sub> acid plus selenium, using Gerhardt Kjeldahtherm until an opaque colour was obtained. The digested sample was rested for 12 hours, diluted with distilled water and made up to the mark in a 250 volumetric flask. 5ml of digest was pipette and distilled with 40% NaOH solution and the ionized ammonium was trapped by boric acid. The distillate was immediately titrated (n = 3) with 0.01N hydrogen chloride. The crude protein was obtained by multiplying the nitrogen with factor: 6.25.

### Statistical analysis

Data obtained were subjected to analysis of variance and significant means were separated by Duncan's multiple range tests using the procedures of SAS (1998).

## RESULTS AND DISCUSSION

Presented in Table 1 are the physicochemical characteristics of Guinea grass ensiled with graded levels of honeycomb waste. The dry matter ranged from 83.2 % in GG + HCW 5 % to 84.43 % in GG + HCW 15%, temperature: 25.5 – 26.67 °C (GG + HCW 15% and GG + HCW 5% respectively) and pH: 5.18 – 5.51 (GG + HCW 10% and GG + HCW 15% respectively). All the silages were firm in texture, of pleasant smell and olive green in colour

which indicated that graded levels of HCW had no effects on these parameters. The result showed that as the level of HCW increased, the temperature of the silage decreased, this is an indication that the silage was well preserved. Also, olive green colour is close to green which was the original colour of the ensiled material. Excessively heated or heat-damaged silages have a brown to dark brown color with a tobacco-type smell. Temperature is one of the essential factors affecting silage colour. The lower the temperature during ensilage, the less will be the colour change. If the temperature obtained for the present silages was above 30 °C, the grass silage would have become dark yellow or closer to brown due to caramelization of sugars in the forage (McDonald *et al.*, 1995). Good silage usually preserves well the original colour of the pasture or forage (t'Mannetje, 1999). The olive green colour was close to the original colour of the grass, which was an indication of good quality silage that was well preserved (Oduguwa *et al.*, 2007). Furthermore, the texture of the silages was not influenced by grading of the honeycomb waste; they were all firm. It had been reported, that firmness was expected to be the best texture of good silage (Kung and Shaver, 2002).

Also, it was observed in the present study that the lower the DM the better the pH. However, the pH values for the silages were within the 4.5 - 5.5 values classified to be pH for good silage (Meneses *et al.*, 2007). The pH is the simplest and quickest way of evaluating silage quality (Jianxin and Jun, 2002). These authors however pointed out that silage quality cannot be satisfactorily evaluated on any single one of these subjective indicators, but on methods of integrated evaluation as recommended by BAPH (1996). Kung and Shaver (2002) in their interpretation of silage analysis stated that good quality grass and legume silage pH values in the tropics range between 4.3 and 4.7. Earlier, Weissbach (1996), had presented a critical pH limit for good silages depending on the dry matter content in which pH should be no higher than  $0.025 \times \text{DM}$  (expressed as percentage) + 3.71. Low levels indicate a stable fermentation, but acidic silage (below pH 4.0) can affect palatability and restrict animal's intake (Genever, 2011).

Proximate composition of ensiled Guinea grass with graded levels of honeycomb waste is shown on Table 2. In all the parameters measured, significant differences ( $P < 0.05$ ) existed. The study showed that the CP, ash, CF and NFE nutrients were enhanced as the HCW level increased in Guinea grass silage. Earlier work indicated that fermentation of feedstuffs enhanced nutritive values of feedstuffs (Eka, 1979;

Adeyemi and Adeyemi, 2000; Adeyemi and Familade). The crude protein in the present study ranged between 7.13% in GG + HCW 5 % and 8.23 % in GG + HCW 15 %. As the level of honeycomb waste increased, the crude protein also increased. This could be due to better proliferation of microbes (proteinous in nature) because of the enabling condition created by improved levels of substrate (HCW). Also, the honeycomb waste contents small amount of honey trapped and not extracted. Hence, though small, crude protein must have been contributed by HCW. However, the crude protein contents (7.13 - 8.23 %) in silage were lower than the range of 11.00 to 13.00 % recommended by NRC (1981) to be capable of supplying adequate protein for maintenance and moderate growth performances in goats. Therefore, it is essential to fortify the silage with protein supplements. Babayemi (2009) suggested that grass silage in Nigeria could be ensiled with other ingredients rich in protein and energy (browse pods, cassava leaf and industrial by-products) to enhance nutritive value of the silage.

The crude fibre was from 48.77 to 52.10 % in GG + HCW 15 % and GG + HCW 5 % respectively. It was found that as the level of HCW increased the crude fibre of silage decreased. This may be connected to degradation of fibre fraction through the activities of microbes. As the HCW increased, the microbes' population increased leading to greater degradation activity. Sniffen (1987) reported that beta-glucanase synthesized by microbes breakdown cellulose, hemicellulose and phenolic polymers; which might be the reason for this significant reduction of crude fibre. Reduction in the fibre level in this case is beneficial; high level of fibre reduces feed intake and digestibility leading to poor performance of animals. Hence, microbes play a vital role in reducing the fibre levels of silage.

Ash content was from 3.23 (GG + HCW 5 %) to 3.6 % (GG + HCW 15 %). The ash follows a direct relationship with increased

levels of HCW – as the HCW increased, the ash content increased. However, the ash content was generally low. In silage, levels of ash over 10 % have been reported to indicate soil contamination and poor fermentation and should not be fed to animals. High ash figures for legume silages are normal due to their high mineral content (Genever, 2011).

Ether extract content ranged from 1.47 – 1.73 % in HCW 15 % and GG + HCW 5 % respectively. As the levels of honeycomb waste increased, the ether extract decreased. Reduction in ether extract contents as the levels of additive (sugarcane) increased

corroborated the current observation (Odedire and Abegunde, 2014). Similarly, Ososanya and Olorunnisomo (2015) reported that the ether extract of ensiled wet brewer's grain with graded levels of corn-cob reduced as the corn-cob increased.

The use of honeycomb waste in silage making as additive was established since, it influenced the pH of the ensiled material. The 15 % HCW exhibited improvement over others in crude protein, ash and nitrogen free extract as well reduced fibre content. Hence, the 15 % level seems the best considering the nutrient composition.

## CONCLUSION AND RECOMMENDATIONS

**Table 1: Physicochemical Characteristics of Guinea grass ensiled with graded levels of honeycomb waste**

Sample	DM (%)	Temperature (°C)	pH	Texture	Smell	Colour
GG + HCW 5%	83.83 <sup>b</sup>	26.67 <sup>a</sup>	5.47 <sup>a</sup>	Firm	Pleasant	Olive green
GG + HCW 10%	83.20 <sup>c</sup>	26.23 <sup>a</sup>	5.18 <sup>b</sup>	Firm	Pleasant	Olive green
GG + HCW 15%	84.43 <sup>a</sup>	25.50 <sup>b</sup>	5.51 <sup>a</sup>	Firm	Very pleasant	Olive green
<b>SEM</b>	0.3210	0.4633	0.3109			

NB: Tables must be prepared using Table format in DOCX or using Ms-Excel and copying and pasting directly to DOCX. Don't use borders except as shown above.

Source: ICAAT, 2018

**Table 2: Proximate composition (g/100g) of Guinea grass ensiled with graded levels of honeycomb waste**

Sample	CP	CF	Ash	EE	NFE
GG + HCW 5 %	7.13 <sup>c</sup>	52.10 <sup>a</sup>	3.23 <sup>c</sup>	1.73 <sup>a</sup>	19.10 <sup>b</sup>
GG + HCW 10 %	7.33 <sup>b</sup>	50.33 <sup>b</sup>	3.53 <sup>b</sup>	1.57 <sup>b</sup>	19.83 <sup>b</sup>



GG + HCW 15 %	8.23 <sup>a</sup>	48.77 <sup>c</sup>	3.60 <sup>a</sup>	1.47 <sup>c</sup>	22.37 <sup>a</sup>
<b>SEM</b>	0.1402	0.1746	0.0911	0.0577	0.2379

<sup>a,b,c</sup>: means with different superscripts within the column are significantly different ( $P < 0.05$ ).  
 Where GG – Guinea grass, HCW – Honeycomb waste, CP – Crude protein, CF – Crude fibre, EE – Ether extract,  
 NFE – Nitrogen free extract.

Table 3: Tables should be concise and informative

Table 4: This is additional table which is presented

Table 5: Yet another table

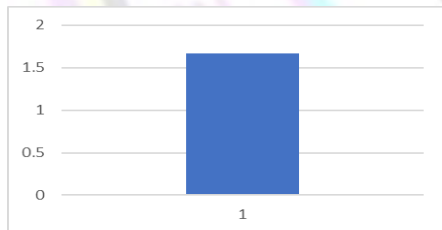


Fig. 1 If you have figures, then reduce the number of tables

## REFERENCES

- Aderinola, O.A., O.A. Lateef, R.T. Binuomote, A. Adeeyo and Jekayinfa, O.A. (2014): Nutritional and microbial contents of varied combination of ensiled *Panicum maximum* and *Vetiveria nigriflora* grass. *Int. J. of Food, Agric. and Vet. Sci.* 4(1):141-148.
- Adeyemi, O. A. and A. A. Adeyemi (2000): Replacement of soybean meal with fermented Theretia cake in layers' diets; Effects on performance, egg quality and nutrient retention. *Nigerian Journal of Animal Production.* 27 (1) 24 – 28.
- Adeyemi, O. A. and Familade, F. O. (2003): Replacement of maize by rumen filtrate fermented corn-cob in layer diets. *Bioresource Technology* 90 (2003) 221 – 224. Doi: 10.1016/S0960-8524(03)00108-1
- Agishi, E.O. 1985. Forage resources of Nigerian range land: In Adu, I.F., Osinowo, O.A., Taiwo, B.B. and Alhassan, W.S. (Eds.). In: Proceedings of National Conference on Small Ruminants 6th-10th October, NAPRI, Zaria. pp.115-124.
- AOAC, (2000): Official Methods of Analysis, 21th edn. (Association of Official Analytical Chemist, Airlington,VA).
- Babayemi O. J. and J. A. Igbekoyi (2008): Ensiling Pasture Grass with Pod of Browse Plans is Potential to Solving Dry Season Feed Shortage of Ruminants in Nigeria. In Eric Tielkes (ed). Competition for resources in a changing world: New drive for rural development. Conference of the International Research on Food Security, Natural Resource Management and Rural Development, Tropentag, 7th-9th October 2008.
- Bamikole, M.A., and Babayemi, O.J. (2004): Feeding goats with Guinea grass-Verano stylo and nitrogen fertilized grass with energy concentrate. *Arch. Zootec.* 53:13-23.
- BAPH (Bureau of Animal Production and Health). (1996): Criteria for Evaluation of Silage Quality (Trial execution). BAPH, Ministry of Agriculture, Beijing.
- Chiba, S., Chiba, H. and Yagi, M. (2005): A guide for silage making and utilization in the tropical regions. A publication of the Japanese Livstock Technology Association, pp 29.
- Eka, O. U. (1979): Effect of yeast fermentation of rice and sweet potatoes on their nutritive status. *Nigerian Journal of Science.* 13: 243 -250.
- Ekiti geography available at (<http://ekitiNigeria.net>) accessed on 8 July, 2017
- Familade, F. O. and O.J. Babayemi (2009): In-vitro gas production and dry matter degradability of ensiled Guinea grass (*Panicum maximum*) harvested at 1 and 3 months regrowths. Proc. Of the 14<sup>th</sup> Annual Conf. of ASAN, held at LAUTECH, Ogbomosho, Oyo state. Pp. 212-214.
- Genever, L. (2011): Making grass silage for better returns. Beef and sheep brp manual 5. Better Returns Programme EBLEX Ashton House Ambury Road South Huntingdon Cambs PE29 3EH [www.eblex.org.uk](http://www.eblex.org.uk) Page: 1-20.
- Jianxin, L. and Jun, G. (2002): Ensiling crop residues. In (Eds. Tingshuang, G., Sanchez, M. D. and Yu, G. P.) Animal Production Based on Crop Residues – Chinese Experiences. FAO Animal Health and Production Paper 149, ISSN 0254-6019, Chapter 4.
- Kung, L. and Shaver, R. (2002): Interpretation and use of silage fermentation analyses reports. Department of Animal and Food Science, University of Delaware Newark, DE19717.
- McDonald P, Edwards RA and JFD Greenhalgh Animal Nutrition (4<sup>th</sup> edition). Longman Publisher. 1988; 200-250.
- McDonald P., R.A. Edwards, J.F.D. Greenhalgh (1995): Animal Nutrition, 5<sup>th</sup> Edition Longman, Hong Kong.
- Meneses, M. D., Megias, J., Madrid, A., Martinez-Teruel, F., Hernandez, J. and Oliver, J. (2007): Evaluation of the phytosanitary, fermentative and nutritive characteristics

- of the silage made from crude artichoke (*Cynadra Scolymus L.*) by-product for feeding ruminants. *Small Ruminant Res.*, 70: 292 – 296.
- NRC (1981): National Research Council. Nutrient Requirements of Goats: Angora, Dairy and Meat in Temperate and Tropical Countries. National Academies Press, Washington D. C., USA, ISBN-13:9780309031851, pp: 91
- Odedire J. A., and T. O. Abegunde (2014): Effect of graded levels of *Saccharum officinarum* as an additive to *Panicum maximum* (Jacq) silage. *African Journal of Food, Agriculture, Nutrition and Development*. 14(3): 1-12.
- Oduguwa BO, Jolaosho AO, Ayankoso MT (2007). Effect of ensiling on the physical properties, chemical composition and mineral contents of Guinea grass and cassava tops silage. *Nig. J. Anim. Prod.* 34: 100 - 106.
- Ogunjobi, A. A., A. C. Ibekwe, O. J. Babayemi and O. E. Fagade (2010). Microbiological evaluation of ensiled Guinea grass and *Albizia saman* pod mixtures and its effect on rumen bacterial population using *in vitro* fermentation technique. *AU Journal of Technology* 13(4): 223-232
- Ososanya and Olorunnisomo (2015): Silage characteristics and preference of sheep for wet brewer's grain ensiled with maize cob. [Livestock Research for Rural Development 27 \(1\) 2015](#)
- SAS (1998): Statistical Analysis System Institute Inc., SAS/ STAT. User's guide. Version 6.3rd edition Carry. North Carolina, USA.943.
- Sniffen, C. J. (1987): Rumen microbial ecology. In: Biotechnology in the feed industry. Alltech Technical Publication.
- t'Mannetje, L.T. (1999): Introduction to the conference on silage making in the tropics in Mannetje(Ed). Silage making in the tropics with particular emphasis on small holders. FAO. Plant production and protection. Paper, 161.
- Weinberg, Z. G. and R. E. Muck (1996) New trends and opportunities in the development and use of inoculants for silage. *FEMS. Microbiol. Rev.*, 1996; 19: 53-68.
- Weissbach, F. (1996): New developments in crop conservation. In: Jones D.I.H., Jones R., Dewhurst R., Merry R. and Haigh P.M. (eds). Proceedings of the 11th International Silage Conference, pp. 11-25. Aberystwyth, UK: Institute of Grassland and Environmental Research.
- Zhang, J. G., O. Tanaka, R. Uegaki, Y. Cali and R. Kobayashi (2000) The effect of inoculation and additives on D(-) and L(+) lactic acid production and fermentation quality of guinea grass (*Panicum maximum* Jacq) silage. *J. Sci. Food Agric.*, 2000; 80: 2186-2189.



## BREEDING OF *Clarias gariepinus* (BURCHELL, 1822) USING WATER LILY LEAF AS SUBSTRATE FOR INCUBATION

Gana<sup>1\*</sup>, A. B., S. M. Tsadu<sup>2</sup>, R. Ibrahim<sup>3</sup>, T. Iriobe<sup>4</sup>

<sup>134</sup> Department of Forestry and Fisheries, Kebbi State University of Science and Technology, P.M.B. 1144, Aliero, Nigeria.

<sup>2</sup> Department of Water Resources, Aquaculture and Fisheries Technology, Federal University of Technology, P.M.B. 65, Minna, Nigeria.

\*E-mail: [abglatiko@gmail.com](mailto:abglatiko@gmail.com), GSM: [08037531711](tel:08037531711)

### ABSTRACT

Three females (*Clarias gariepinus*) brood stocks weighing 336g, 378, and 405g were bred by artificial induced breeding and eggs were incubated on aquatic substrates (designated as T1: surface of water lily leaf; T2: backside of water lily leaf and T3: Kakaban as control) to determine the hatchability and survival rate of the hatchlings. The fertilized eggs were attached to water lily leaves and incubated in glass aquaria (60 x 30 x 30 cm<sup>3</sup>) that contained clean water for hatching. The eggs hatched with higher percentage recorded in T2 (86%), T3 (84%) and T1 (61%) respectively. The T2 had the highest final weight gain (1.14 g), followed by T1 (1.00 g) and T3 had the least of 0.96 g. Also the mean percentage survival of the 250 fry stocked in the glass aquaria T1, T2, and T3 were 90.90 %, 90.80 % and 91.80 % respectively. The water quality parameters (Temperature, dissolved oxygen, biological oxygen demand, alkalinity, conductivity, pH and hardness) monitored were within the desirable range of fish culture.

**KEYWORDS:** Aquatic, substrates, aquaria, broodstocks,

### INTRODUCTION

Aquaculture is the growing of aquatic organisms including finfish, mollusks, crustaceans and aquatic plants in a confined environment (Hambrey, 2016), which is the fastest developing sector of the world food economy, rising by more than ten percent per year and accounts currently for more than thirty percent of all consumed fish (Huntingford *et al.*, 2006). Fish Farming is the most widely class of aquaculture, which involves culturing fish commercially in ponds, tanks, or ocean confinements, usually for food (Funge-Smith and Phillips, 2001).

Among the catfishes, the air breathing species *Clarias gariepinus* is a popular culturable fish in Nigeria due to its hardy nature, fast growth, tasteful flesh, highly fecund, tolerance to adverse ecological condition enable its high density culture with a high production per unit area (Olaleye, 2005; Adah *et al.*, 2014), which has assumed the status of fast expanding industry in Nigeria (Fagbuaro, 2010).

The basic requirement of the controlled fish farming is the supply of fish seedlings, however, due to spontaneous captive breeding, short supply of quality seed and dependency on wild seeds, which is unreliable, time consuming and uneconomical are major constraints for culturing the fish (Nasir *et al.*, 2014). To overcome such problems, breeding is thought to be the only alternative method for quality

seed supply or production, which can be carried out in a hatchery (Olanrewaju *et al.*, 2009). Hatchery is a facility that releases juvenile fish into the wild water for recreational fishing or to supplement a species to natural waters (Martins *et al.*, 2010).

Breeding or hatching of eggs of *Clarias gariepinus* and rearing of fingerlings are very readily done using simple technology that involves induction by hypophyztation. This is achieved by injecting hormone (natural or artificial) into the fish which help to complete the maturity of eggs of the spawning fish and the emergence of eggs and milt which permits natural or artificial fertilization of eggs. In the course of breeding *Clarias gariepinus* in the hatchery, the need for fry survival and growth becomes crucial to building of stocks within a reasonable time (Lamai, 1999). However, information on the use of water lily leaves as an incubating substrate is relatively low in the study area.

The commercially available synthetic inducing hormones in readymade form are becoming very popular and found to be efficient in successful spawning of fishes (Cheah and Lee, 2000). Among several inducing agents used in fish breeding, ovaprim was found to be effective in fish breeding. The use of synthetic inducing agents for successful ovulation followed by stripping in catfish is a

common practice and has been studied in several occasions (Tanfermin *et al.*, 1997).

## METHODOLOGY

This experiment was conducted at Prof. S.M. Tsadu indoor hatchery, in Department of Water Resources, Aquaculture and Fisheries Technology, School of Agriculture and Agricultural Technology, Federal University of Technology Minna, Bosso Campus, Nigeria

The research was conducted using 9 glass aquaria (60 x 30 x 30 cm<sup>3</sup>); having 3 treatments and 3 replicates each, designated as T1 (treatment 1, front surface of water lily leaf), T2 (treatment 2, back side of water lily leaf), and T3 (treatment 3, kakaban as control). Three grams of eggs were weighed (using electronic sensitive weighing balance) and incubated per glass aquarium. Aerators were used to aerate the water in the aquarium. Seventy two (72) hours after hatching, the fries were weighed and measured (mean weight and length) and were stocked at 250 fries per glass aquarium. During the trial the fish were fed 5 times daily to satiation with Artemia (54 % CP) for four weeks and fishmeal (58 % CP) for four weeks, uneaten feed and faecal materials were siphoned every morning from the aquaria by using a rubber hose. Sampling (random) was done at two weeks interval by removing some fish out from each aquarium using a hand net and measured (total length and weight) using a sensitive weighing balance (Ohaus AR2130) and plastic ruler.

The broodstocks used for this experiment that weighed 336g, 378g, and 405g were sourced from fish tank of the Department of Water Resources, Aquaculture and Fisheries Technology, Federal University of Technology Minna, Niger State. The female gravid broodstocks were selected according to their swollen soft abdomen and for male according to their swollen reddish genital papilla as described by Majolagbe *et al.* (2012).

The amount of ovaprim administered (using 1 ml graduated syringe and needle) on each of the female fish that weighed 336g, 378, and 405g were 0.17 ml, 0.19 ml and 0.20 ml respectively through intramuscular method of injection. The females were then separated into different bowls and covered with nets to avoid escape. After 12 hours of latency period, the female fish were carefully catch with a net and stripped by gently pressing its abdomen with a thumb from the pectoral fin towards the anus. The stripped eggs were collected in a dry plastic bowl. Freshly dissected testes were squeezed into saline solution,

mix and distributed evenly on top of the eggs. The eggs were then mix gently using a feather, and immediately afterwards clean water was added to the eggs in container.

The fertilized eggs (3 grams) were incubated in glass aquaria (60 x 30 x 30 cm<sup>3</sup>) at the mean temperature of 28<sup>o</sup>C on the surface (plate 4), back side (plate 5) of the leaf, and Kakaban (plate 6).

The following data on hatchability, percentage hatchability, mortality and Percentage mortality, were collected as used by Tsadu *et al.* (2016). 0.5 gram of eggs was weighed and manually counted, which amount to 304 number of eggs. 1 gram = 304 × 2 = 608, therefore, 3 grams = 608 x 3 = 1824 eggs

$$\text{Hatchability} = N - \text{ND}$$

Where N: Number of incubated eggs  
ND: Number of dead eggs

$$\% \text{ Hatchability} = \frac{N - \text{ND}}{N} \times 100$$

$$\text{Mortality} = N - \text{NH}$$

Where NH: Number of hatched eggs

$$\% \text{ Mortality} = \frac{N - \text{NH}}{N} \times 100$$

The hatchlings growth parameters were analysed in terms of Body weight gain (BWG), percentage survival rate (% SR), specific growth rate (SGR), and protein efficiency ratio (PER), they were calculated using the formulae described by Bake *et al.* (2014).

$$\text{BWG} = \text{FW (g)} - \text{IW (g)}$$

Where FW: Final weight  
IN: Initial weight

$$\text{SGR (\%)} = \frac{\ln \text{FW (g)} - \ln \text{IW (g)}}{\text{Feeding period (day)}} \times 100$$

$$\text{PER (\%)} = \frac{\text{Wet body gain}}{\text{Protein intake (g)}} \times 100$$

$$\text{SR (\%)} = \frac{\text{Stocking rate} - \text{mortality}}{\text{Stocking rate}} \times 100$$

The water quality parameters recorded during the experiment include dissolve oxygen (DO), pH, Temperature, Conductivity, Biological Oxygen Demand (BOD), Hardness and Alkalinity. The mercury thermometer, pH meter and conductivity meter were used to determined temperature, pH and



conductivity respectively. The DO, BOD, hardness and alkalinity were determined using Winkler's (1888) titrimetric method.

The data collected on the parameters were subjected to one-way analysis of variance (ANOVA) and statistical differences among the means were tested at 95 % level of confidence using Duncan Multiple Range Test.

## RESULTS AND DISCUSSION

The results of mean hatching, mortality, percentage hatching and percentage mortality of *Clarias gariepinus* eggs incubated in glass aquaria are presented in table 1; the percentage survival rate and growth parameters in table 2; and the mean water quality variables are presented in Table 3.

The grandness of aquatic substrates as an alternative for incubation of eggs in induced breeding, has been demonstrated in recent years (Tsadu *et al.*, 2016). The result obtained in percentage hatchability showed that T2 (75.2 %) perform better than T1 (54.1 %), but there were no variance between T2 and T3 (78.2 %). The value obtained in this study is higher than the value obtained in Gikonyo *et al.* (2017) while investigating the hatching rates of African catfish (*Clarias gariepinus*) eggs using Nile cabbage (53 %) and Kaka Bans (13 %) substrates. The variation may be attributed to the use of different aquatic substrates.

The growth parameters of the experimental fish indicate that T2 (1.14±0.03) obtained higher final weight gain in comparison with T1 (1.00±0.03) and T3 (0.96±0.04). This result support the past observation by Lamai (1999) and Ojutiku (2008) that natural organisms enhance the growth of fish at the early stages of their growth (development). This was shown through the performance growth (weight and length) increase of *Clarias gariepinus* fry fed with Artemia diet and fishmeal. Though the result of the survival rates for the fry in this experiment were no significantly different, but in variance with the result recorded by Lamai (1999). Similarly, Ovie, (2003) observed that the growth and survival of fish fry are enhanced when fed with the live forms of plankton organisms. This is due to their easy availability, high reproductive potential, short generation time, and nutritional quality capable of providing essential amino and fatty acids to the young growing fish. Other qualities are suitable of size smaller than the mouth diameter of the fry to enable easy handling and ingestion.

The temperature (26.33 – 26.67°C) was within the desirable range of fish culture. Santhosh and Singh (2007) reported suitable water temperature for carp culture is ranges from 24 – 30°C. The dissolved oxygen (5.17 – 5.87 mg/l) recorded was in accordance with the report of Ekubo and Abowei (2011) stating that DO of 5 mg/l are adequate in fish ponds. However, oxygen depletion in water leads to poor feeding of fish, starvation, reduced growth and more fish mortality, either indirectly or directly (Bhatnagar and Garg, 2000). The biological oxygen demand ranges between (2.43 – 3.03 mg/l) which is in accordance with the report of Clerk (1986), stating that BOD range of 2 – 4 mg/l does not show pollution while levels beyond 5 mg/l are indicative of severe pollution. The hardness recorded in this study is between 74 – 79 mg/l. Stone and Thomforde (2004) recommend water hardness of 50 – 150 mg/l. The conductivity (220.67 – 249.67 µs/cm) recorded was in accordance with the recommendation of Stone and Thomforde (2004), that desirable range of 100 – 2000 µs/cm for pond fish culture. However, Sikoki and Veen (2004) described a conductivity range of 3.8 – 10 µs/cm extremely poor in chemicals. The pH (7.26 – 7.34) recorded is in line with report of Wurts and Durborow (1992), relating that ideal pH level for aquaculture is ranges from 6.5 – 9.0.

## CONCLUSION AND RECOMMENDATIONS

In conclusion, the effectualness of water lily leaves as an egg incubation substrate has been successfully demonstrated in this study. It has equally provided a basic information on the use of water lily leaves as substrate for incubation of *Clarias gariepinus* eggs. The result obtained from this research reveal noteworthy significance between the front surface and backside of water lily leaves. Hence the backside side of water lily leaf can be used for incubation of *Clarias gariepinus* eggs with reputable hatching results.



Table 1: Hatchability, mortality, percentage hatchability and percentage mortality of *Clarias gariepinus* eggs incubated on substrates

Treatment	Hatchability ±SE	Mortality ±SE	% Hatchability ±SE	% Mortality ±SE
1	986.0±53.2 <sup>b</sup>	838.0±53.2 <sup>a</sup>	54.1±2.9 <sup>b</sup>	45.9±2.9 <sup>a</sup>
2	1372.3±24.4 <sup>a</sup>	451.7±24.4 <sup>b</sup>	75.2±1.3 <sup>a</sup>	24.8±1.3 <sup>b</sup>
3	1426.3±12.7 <sup>a</sup>	397.7±12.7 <sup>b</sup>	78.2±0.7 <sup>a</sup>	21.8±0.7 <sup>b</sup>

Values in the same column with different superscript letters are significantly different (P<0.05) from each other.

Table 2: Growth parameters of the experimental fish incubated on different substrates

Treatment	IW (g) ±SE	FW (g) ±SE	BWG (g) ±SE	SGR (%) ±SE	PER ±SE	SR (%) ± SE
1	0.0083±0.00	1.01±0.02 <sup>b</sup>	1.00±0.02 <sup>b</sup>	8.60±0.10	1.50±0.07	90.90±1.95
2	0.0087±0.00	1.14±0.03 <sup>a</sup>	1.14±0.03 <sup>a</sup>	8.70±0.10	1.40±0.08	90.80±2.35
3	0.0083±0.00	0.97±0.04 <sup>b</sup>	0.96±0.04 <sup>b</sup>	8.60±0.06	1.50±0.06	91.80±1.68

Values in the same column with different superscript letters are significantly different (P<0.05) from each other.

Table 3: Mean water quality parameters monitored during the experiment

Parameters	Treatments		
	T1	T2	T3
Temperature (°C)	26.67	26.67	26.33
Ph	7.26	7.34	7.28
Conductivity (µs/cm)	236.33	249.67	220.67
DO (mg/l)	5.17	5.50	5.87
BOD (mg/l)	2.47	2.43	3.07
Alkalinity (mg/l)	112.00	105.67	118.00
Hardness (mg/l)	74.00	79.00	75.00

## REFERENCES

- Adah P. M, Onyia L.U and R.A. Obande, (2014). Fish Hybridization in Some Catfishes: A Review. *Biotechnology*, 13: 248-251. DOI: [10.3923/biotech.2014.248.251](https://doi.org/10.3923/biotech.2014.248.251)
- Bake, G. G., Martins, E. I. and Sadiku, S. O. E. (2014). Nutritional evaluation of varying levels of cooked flamboyant seed meal (*Delonix regia*) on the growth performance and body composition of Nile tilapia (*Oreochromis niloticus*) fingerlings. *Journal of Agriculture, Forestry and Fisheries*, 3 (4), 233 – 239. doi:10.11648/j.aff.20140304.14 ISSN:2328-5648
- Bhatnagar, A. and Garg, S.K., (2000), Causative factors of fish mortality in still water fish ponds under sub-tropical conditions, *Aquaculture*, 1(2): 91-96.
- Cheah M.S.H and Lee C.L. (2000). Induced ovulation of the Australian eel-tailed catfish *Neosilurus ater* (Perugia) with Ovaprim. *Asian Fisheries Science* 13: 87-96.
- Ekubo, A.A. and Abowei, J.F.N., (2011). Review of some water quality management principles in culture fisheries, *Research Journal of Applied Sciences, Engineering and Technology* 3(2): 1342 – 1357.
- Fagbuaro, O., (2010). Aquacultural implications of Cephalic deformity in the African Catfish, *Clarias gariepinus* (Burchell, 1822). *Journal of Applied Environmental Science* 6: 112-119.
- Funge-Smith, S. Phillips, M.J. (2001). Aquaculture systems and species. In R.P. Subasinghe, P. Bueno, M.J. Phillips, C. Hough, S.E. McGladdery and J.R. Arthur, eds. *Aquaculture in the Third Millennium. Technical Proceedings of the Conference on Aquaculture in the Third Millennium, Bangkok, Thailand, 20-25 February 2000*. 129 – 135. NACA, Bangkok and FAO, Rome.
- Gikonyo, J.M. Felix M K. and Benson O.I. (2017). Comparative assessment of hatching rates of African Catfish (*Clarias gariepinus*) eggs using Nile cabbage and Kaka Bans substrates. *Livestock Research for Rural Development* 29 (9).
- Hambrey, J., (2016). *Aquaculture in England, Wales and Northern Ireland: An Analysis of the Economic Contribution and Value of the Major Sub-sectors and the Most Important Farmed Species*. In press.
- Huntingford, F. A; Adams, C; Braithwaite, V. A; Kadri, S; Pottinger, T. G; Sandoe, P and Turnbull, J. F (2006). "Current issues in fish welfare". *Journal of Fish Biology*, 68 (2): 332 – 372. doi:10.1111/j.0022-1112.2006.001046.x
- Lamai, S.L. (1999). The effect of different diets and their particulates sizes on their utilization survival and growth of 5 days old *Clarias gariepinus* (Burchell 1822) fry. *Nigeria Journal of Biotechnology* 10 (1): 142 – 146.
- Majolagbe, F.A., Awodiran, M.O. and Awopetu, J. I. (2012). Electrophoretic studies of *Clarias gariepinus* (Burchell, 1822) and *Heterobranchus bidorsalis* (Geoffroy Saint-Hilaire, 1809) and their hybrids. *Ife Journal of Science* 14 (1): 167 – 176.
- Martins C.I.M., E.H. Eding, M.C.J. Verdegem, L.T.N. Heinsbroek, O. Schneider J.P. Blancheton, E. Roque d'Orbcastel and J.A.J. Verreth (2010). New developments in recirculating aquaculture systems in Europe: A perspective on environmental sustainability. *Journal Aquacultural Engineering*, 43 (3), 83-93. <http://dx.doi.org/10.1016/j.aquaeng>.
- Nasir M.A., S. Farida, T. Laurat, M.D. Nafisat and D. Awawu, (2014). Survey of Functional and Non Functional Fish Hatcheries in Jigawa State, Nigeria. *Journal of Fisheries and Aquatic Science* 9: 473 – 477.
- Ojutiku, R.O. (2008). Comparative survival and growth rate of *Clarias gariepinus* and *Heteroclarias* hatchlings fed live and frozen *Daphnia*. *Pakistan Journal of Nutrition*, 7(4): 527 – 529.
- Olaleye, V.F. (2005). A review of reproduction and gamete management in the African catfish, *Clarias gariepinus* (Burchell 1822). *Ife Journal of Science* 7 (1): 63 – 70
- Olanrewaju, A.N., O.O. Abelege and A.K. Saidu, (2009). Growth and production of fry/fingerling of *Clarias gariepinus* in indoor tanks in arid zones, Nigeria. Proceedings of the 24<sup>th</sup> Annual Conference of the Fisheries Society of Nigeria Akure, October 26-28, 2009, Akure, Nigeria 8 – 10.
- Ovie, S.O. (2003). Macro nutrient requirements of the giant African mudfish, *Heterobranchus longifilis* (Val. 1840) Ph. D Thesis, School of Agriculture and Agricultural Technology, Federal University of Technology, Minna, Nigeria 216.

- Peters, R.H. (1987). National live fish food production and use in hatcheries in Nigeria on National Aquaculture Diagnosis Survey (May – July 1994) published by National Institute for Freshwater Fisheries research, 35 – 40.
- Santhosh, B. and Singh, N.P. (2007). Guidelines for water quality management for fish culture in Tripura, ICAR Research Complex for NEH Region, Tripura Center, 29
- Tan-Fermin, J.D., T. Miura, H. Ueda, S. Adachi and K. Yamauchi, (1997). Testicular histology and serum steroid hormone profiles in hatchery-bred catfish *Clarias macrocephalus* (Gunther) during an annual reproductive cycle. *Fisheries Science* 63: 681 – 686.
- Tsadu, S. M., Alfa, L. and Yisa, T. A. (2016). Suitability of aquatic substrates on hatchability and survival of hybrid eggs of *Heterobranchus longifilis* and *Clarias gariepinus*. *Nigerian Journal of Agriculture, Food and Environment* 12 (4): 135 – 139.
- Winkler, L. (1888). “Die Bestimmung des in Wasser Sauerstoffes”. *Berichte der Deutschen Chemischen Gesellschaft*, 21:2. 2843 – 2855. Doi: 10.1002/cber.188802102122.





## INFLUENCE OF MINERAL NITROGEN-LEVELS AND FOLIAR FERTILIZER ON INOCULATED SOYBEAN NODULATION, GROWTH AND YIELD

Ezekiel.-Adewoyin D. T.<sup>1</sup>, Tanko F<sup>1</sup>., Shokalu A. O.<sup>2</sup>, Emmanuel C. O.<sup>2</sup>, Kayode C. O.<sup>3</sup>., Makinde A. I.<sup>3</sup>

<sup>1</sup>Dept. of Soil and Land Management, School of Agric. and Agric. Tech., Federal University of Technology, P.M.B. 65, Minna, Nigeria. <sup>2</sup>National Horticultural Research Institute, P.M.B. 5432, Idi-Ishin, Ibadan, Nigeria. <sup>3</sup>Federal College of Agriculture, I.A.R. and T. P.M.B. 5029, Apata, Ibadan, Nigeria.

### ABSTRACT

The need for N in Soybean production has been confirmed by so many reseachers; however the need for nutrient supplement at leaf senescence stage to sustain successful seed formation, pod filling and quality seed harvest has not really been reported in the Northern region of Ghana. The influence of N rate and time of application on soybean cultivation has also aggravated a lot of research questions. Therefore, an experiment was conducted to evaluate the response of soybean plant height, canopy spread, nodulation, pod formation and grain yield to mineral fertilizer (30 kg P<sub>2</sub>O<sub>5</sub> and K<sub>2</sub>O each as basal application) with ammonium sulphate as starter N (25kg Nha<sup>-1</sup>), then a top dressing (25 or 50kg Nha<sup>-1</sup>) at mid-vegetative stage, foliar fertilizer (Boost xtra 4 litre ha<sup>-1</sup>, at vegetative/early podding stage) and 5 g seed<sup>-1</sup> of *Bradyrhizobium japonicum* inoculant. The experiment was a Randomized Complete Block Design replicated three times. The results obtained shows that the appropriate timing of N and foliar fertilization could enhance soybean growth and grain yield. Plant height and canopy spread response to the application of initial 25kg Nha<sup>-1</sup> was an indication that a minimum level of N is a necessity for soybean establishment. Also soybean pod formation and seed grain were all proofs of significant (P<0.05) influence of the applied treatments on soybean development as compared to the Control. Infact, an impressive grain yield (94% increase) was produced from the plot treated with 50kg Nha<sup>-1</sup>+BX compared to Control. However, the lowest N-level (25kg Nha<sup>-1</sup>) used as sole and better still it's combinations with BX or INO and the combination of the three (25kg Nha<sup>-1</sup>+INO+BX) also gave substantial increase of 50% and above grain yield over the Control. Hence, the use of fertilizer (mineral, foliar and bio-fertilizer) is paramount in augmenting soybean production in the study area. The choice, rate and time of application depend on the farmer's financial capability.

**KEY WORD:** Soybean, Canopy spread, *Bradyrhizobium japonicum*, Scenecense, Boost xtra

### INTRODUCTION

Nitrogen (N) and foliar fertilization are not traditional nutrient management practices for soybean production. Because soybean as a legume plant is expected to obtain adequate N through mineral N assimilation and symbiotic N<sub>2</sub> fixation (Hartwig, 1974). But because of soybean high N requirement farmers have difficulty in satisfying its N demands. Hence, mineral N fertilization is a crucial factor in oil - seed legume production as reported by Rathke *et al.* (2005). Studies carried out on the effect of fertilizer - N on soybean growth and N<sub>2</sub> fixation showed that N fertilization increased growth but reduced N<sub>2</sub> fixation by causing reduction in nodule number and nodule weight (Chen *et al.*, 1992; Starling *et al.*, 1998). This however is said to be dependent on quite a number of factors including the soil type, climate, farming system, farmer's ability to afford fertilizer and applying it at the required rate and time (E.-Adewoyin, 2014). Few studies have evaluated the effect of Nitrogen (25kg Nha<sup>-1</sup>), its top dressing (25kg Nha<sup>-1</sup> and 50kg Nha<sup>-1</sup>) at mid-vegetative stage and foliar fertilizer (macro and micro nutrients) application at mid-vegetative to early podding stage

on soybean growth and yield in the Savanna agro ecological zone of Ghana.

Inoculation is a technology used for the manipulation of rhizobia populations for improved crop productivity and soil fertility (Keyser and Li, 1992). Peoples *et al.* (1995) reported that inoculation can lead to the establishment of large populations of rhizobia in the rhizosphere and improve nodulation and N<sub>2</sub> - fixation. However soybean response to inoculation is dependent on so many factors including the inherent field variability and differences in environmental and edaphic conditions (van Kessel and Hartley, 2000). Thies *et al.* (1991) reported that the response of legumes to inoculation depends to a large extent on the number of rhizobia already established in the soil, the availability of soil nitrogen and the management practices put in place. In general, and as confirmed by Araujo *et al.* (1994), the effective and efficient use of inoculation occur in soils which are depleted or contain low indigenous rhizobia population and when there is an established but inefficient rhizobia population. Dorivar *et al.* (2009) reported a positive response of rhizobia inoculation to nodulation, shoot biomass and grain

yield while Otieno *et al.* (2009) reported increased nodule number, nodule dry weight but not shoot biomass, root dry weight and grain yield. These variations in response to inoculation could be due to many factors including soil pH, temperature, moisture content and soil nutrient status (especially N).

Soybean flowering phase is followed by pod formation, leaf senescence and seed filling. The peak of flowering is the peak of nodule activities (BNF) after which the nodules rupture and leaf falls. Studies have shown that the use of nutrient supplements at late vegetative, early or late reproductive stage prolongs plant vegetative stage and therefore complements biological nitrogen fixation, which tends to decline at this stage to sustain pod formation and seed filling (Ashour and Thaloath, 1993). Garcia and Hanway (1976) reported yield increases of 27 to 31% when liquid N – P – K - S fertilizer was applied at late reproductive stages (R5 to R6). Wesley *et al.* (1998) and Mallarino *et al.* (2001) also reported an increase in yield due to the use of foliar fertilizer. On the contrary, Boote *et al.* (1978) and Parker and Boswell (1980) reported neither increase nor decrease in yield of soybean to the use of foliar fertilizer. While, Clement *et al.* (2013) reported that the application of foliar micronutrients on the double inoculation of fungi - Rhizobium increased grain yield. Similarly, Ross *et al.* (2006) and Bellaloui *et al.* (2010) indicated the importance of some micronutrients such as boron on soybean nitrogen fixation and seed yield. Due to all this controversial reports there is need to investigate the response of inoculated soybean to N fertilizer levels (split application) and foliar fertilizer (boost xtra) especially in the Northern region of Ghana.

### 1.1 Objective

To evaluate the effectiveness of Foliar fertilizer (Boost xtra), Mineral nitrogen levels and *Bradyrhizobium japonicum* inoculation on nodulation, growth and yield of soybean.

### 2.0 Materials and Methods

#### 2.1 Experimental site

This experiment was carried out at the experimental field of Savanna Agricultural Research Institute, Nyampala, located about 16 km west of Tamale, and lies on latitude 09° 23'22.4'' N and longitude 01° 00' 12.1'' W, at an elevation of 195 m above mean sea level of the interior Guinea Savanna agro - ecological zone of Ghana. The rainfall is mono - modal (April / May – October), and a dry season with severe

harmattan wind occurring between December and January. The total annual rainfall ranges from about 800 to 1,500 mm (SARI, 2009) and the annual temperature ranges from a minimum of 13 °C to a maximum of 40 °C, with a mean of 28 °C. The experimental field had been previously cultivated to hot pepper for three consecutive years. The soil of the study area is Tingoli series classified as Ferric Luvisol (FAO 1988).

#### 2.2 Soil sampling and preparation

Composite soil samples for laboratory analysis were taken from (0 - 20 cm depth) the experimental site prior to land preparation. The samples were taken randomly across the field using a soil augur. Samples were then air dried, thoroughly mixed and passed through a 2 mm mesh sieve and packaged for laboratory analyses.

#### 2.3 Determination of soil chemical and physical properties

Soils collected from the experimental field were analyzed for pH in a 1:2.5 suspension of soil to water ratio using electrometric method, organic carbon content by the modified Walkley Black procedure (Nelson and Sommers, 1982), total N Kjeldahl by distillation procedure (Bremner and Mulvaney, 1982), available phosphorus by Bray 1 (Bray and Kurtz, 1954) and potassium using flame photometry as described by Helmke and Sparks (1996). Exchangeable bases ( $\text{Ca}^{2+}$ ,  $\text{Mg}^{2+}$ ,  $\text{K}^{+}$ ,  $\text{Na}^{+}$ ) was determined using 1N  $\text{NH}_4\text{OAc}$  extract method (Thomas, 1982), after which  $\text{Ca}^{2+}$  and  $\text{Mg}^{2+}$  were determined from Atomic Absorption Spectrometer, while  $\text{K}^{+}$  and  $\text{Na}^{+}$  were obtained by the flame photometer. Exchangeable acidity ( $\text{Al}^{3+}$  and  $\text{H}^{+}$ ) was determined by titrimetric method after extraction with 1N KCL (Mclean, 1982). Copper, iron and manganese in the soil were determined using the diethylenetriamine pentaacetic extraction method. Ten (10) grammes air dried soil was weighed into separate plastic bottles for Cu, Fe and Mn after which hundred milliliters DPTA extract was added to each. It was shaken for 2 hours and filtered with Whatman No. 42 filter paper. Their values were all read on an Atomic Absorption Spectrophotometer using the appropriate standards. Soil physical properties was also determined using Bouyoucous hydrometric method (Bouyoucous, 1962).

#### 2.4 Most Probable Number method (MPN)

The estimation of the rhizobia populations in the study fields were carried out using the most probable number method (MPN) (Vincent, 1970). Uniform seeds of good viability were surfaced sterilized with alcohol and hydrogen peroxide as described by



Somasegaran and Hoben (1994). The seeds were pre-germinated in Petri dishes containing moist sterile cotton wool and incubated between the temperatures of 20 °C and 30 °C. Seeds were then transferred to plastic growth pouches containing Broughton and Dilworth N-free (Broughton and Dilworth, 1970) plant nutrient solution aseptically with the help of forceps. The growth pouches were arranged in a wooden rack and kept in the greenhouse awaiting inoculation.

Five – fold dilutions of each of the samples were made as follows: Five different test tubes were filled with 20ml distilled water. With a pipette, 5ml solution was transferred from the 10<sup>-1</sup> dilution (which was prepared by vigorously shaking 100g of the sample in 400ml of the sterile distilled water) into one of the five different test tubes. Series of dilutions were then made from 10<sup>-1</sup> to finally achieve 10<sup>-6</sup>. Each growth pouch was inoculated with 1ml of the dilutions replicated four times for each dilution series, using different pipette tips and started from the highest dilution to prevent contamination. The plants were watered with sufficient N – free nutrient solution when required. Nodulation was assessed after twenty eight days after which the total number of pouches that nodulated for each replicated dilution unit was used to determine the number of rhizobia per gram of soil using charts generated by MPNES software (Woomer *et al.*, 1990)

#### 2.4 Land preparation and layout

The land was ploughed, harrowed and ridges were constructed mechanically. Plots measuring 7m by 7m were demarcated for planting. An alley of 2m between plots and 3m between blocks were also constructed.

#### 2.5 Inoculation

Soybean seeds (var. Jenguma) were inoculated prior to planting with a peat - based inoculum of *Bradyrhizobium japonicum* at the rate of 5 g per one kilogram of seed using the slurry method as described by Woomer *et al.* (1994).

#### 2.6 Planting

Soybean seeds were planted at two seeds per hill on ridges made at 0.05 m within rows and 0.75 m between rows covered with soil and thinned to one seed per hill two weeks later. Planting was done in June 2012 starting with the un-inoculated plots followed by the inoculated plots to avoid contamination.

#### 2.7 Treatments

The treatments used for the study were: T<sub>1</sub>=25kg Nha<sup>-1</sup>, T<sub>2</sub>=50kg Nha<sup>-1</sup>, T<sub>3</sub>= 75kg Nha<sup>-1</sup>, T<sub>4</sub>=<sup>1</sup>Boost xtra (BX), T<sub>5</sub>= INO, T<sub>6</sub>=25kg Nha<sup>-1</sup>+*Bradyrhizobium japonicum* (INO), T<sub>7</sub>=50kg Nha<sup>-1</sup>+INO, T<sub>8</sub>=75kg Nha<sup>-1</sup>+INO, T<sub>9</sub>=BX+INO, T<sub>10</sub>=25kg Nha<sup>-1</sup>+BX, T<sub>11</sub>=50kg Nha<sup>-1</sup>+BX, T<sub>12</sub>=75kg Nha<sup>-1</sup>+BX, T<sub>13</sub>=25kg Nha<sup>-1</sup>+BX+INO, T<sub>14</sub>=50kg Nha<sup>-1</sup>+BX+INO, T<sub>15</sub>=75kg Nha<sup>-1</sup>+BX+INO, T<sub>16</sub>=Control

#### 2.8 Fertilizer application

Nitrogen was applied as ammonium sulphate. The 50 and 75kg Nha<sup>-1</sup> treatments were applied in two splits; 25kg Nha<sup>-1</sup> was applied seven days after planting and top dressed at 50% flowering with 25 and 50kg Nha<sup>-1</sup> (to give 50 and 75 kg Nha<sup>-1</sup>) respectively. Triple super phosphate and Muriate of potash were applied basally (30kg ha<sup>-1</sup> each) seven days after planting. The foliar fertilizers (Boost Xtra) frequency of applications was modified to avoid leaf injury. However, the recommended rate (4L ha<sup>-1</sup>) by the producers was considered, given 2.25ml per plant<sup>-1</sup>. It was applied at two weeks intervals from 50% flowering (6<sup>th</sup> week) to early podding stage (4 times) corresponding to 20% NPK, 1.5% MgO, 0.15%, 0.075% Mn, Fe and Zn, 0.0012% Co and Mo.

#### 2.9 Experimental design

Each treatment plot of 7 × 7m<sup>2</sup> was made of nine rows with 2 m between plots. The experiment was laid as Randomized Complete Block Design (RCBD) with sixteen treatments replicated three times.

#### 2.10 Statistical analysis

Data obtained from the trial was analyzed with GenStat 9<sup>th</sup> edition (2007), using analysis of variance (ANOVA). The various levels of significance (5%) and means were separated using Duncan Multiple Range Test (DMRT). The count data were transformed (Log) before running the analysis.

### 3.0 Results

#### 3.1 Soil physical and chemical properties and MPN count of the indigenous rhizobia

The soil of the experimental site was slightly acidic and low in all soil nutrients measured (Table 1). The organic carbon (< 20 g kg<sup>-1</sup>), total nitrogen (< 1 g kg<sup>-1</sup>), exchangeable cations (< 5 C mol kg<sup>-1</sup>), effective cation exchange capacity (< 5 C mol kg<sup>-1</sup>) and extractable P (< 10 mg kg<sup>-1</sup>) were low. The MPN count of indigenous rhizobia population at the study area was estimated as 5.12 × 10<sup>1</sup> cells g soil<sup>-1</sup> (E.-Adewoyin, 2014).



**Table 1. Soil physical and chemical properties and MPN count of the experimental site**

Soil properties	Value
pH (1:2.5 H <sub>2</sub> O)	5.5
Organic carbon (%)	0.9
Total N (g kg <sup>-1</sup> )	0.5
Extractable P (mg kg <sup>-1</sup> )	5.7
Ca (C mol kg <sup>-1</sup> )	2.30
Mg (C mol kg <sup>-1</sup> )	0.71
K (C mol kg <sup>-1</sup> )	0.06
Na (C mol kg <sup>-1</sup> )	0.08
Mn (mg kg <sup>-1</sup> )	4.09
Cu (mg kg <sup>-1</sup> )	9.02
Fe (mg kg <sup>-1</sup> )	19.00
Exchangeable acidity (C mol kg <sup>-1</sup> )	0.73
Sand (%)	68
Silt (%)	24
Clay (%)	8
Texture	Sandy loam
MPN (cell g <sup>-1</sup> soil)	5.12 × 10 <sup>1</sup>

### 3.2. Effect of Foliar fertilizer (BX), *Bradyrhizobium japonicum* (INO) and Nitrogen levels on soybean plant height and canopy spread

Soybean plant height and canopy spread result was as shown on Table 2. The application of 50kg Nha<sup>-1</sup>+BX resulted in the highest plant height which ranged from 33.38 – 691.3cm (6-14<sup>th</sup> WAP). At 6WAP the tallest plant gotten from the application of 50kg Nha<sup>-1</sup>+BX was at par with the other treated plots except for INO+25kg Nha<sup>-1</sup>, INO+BX, sole BX, sole INO and Control. The combination of the different fertilizers used (INO, N-levels and BX) aided plant height increase all through the experiment, ranging from 29.45 – 691.3cm plant<sup>-1</sup> (6-14WAP), except INO+BX which was at par with Control. Soybean canopy spread was enhanced with the application of INO+75kg Nha<sup>-1</sup>+BX (53.00cm)

at 6WAP, though significantly at par with other treated plots except; sole BX, INO+BX, sole INO and Control. At 8WAP the application of 50kg Nha<sup>-1</sup>+BX and INO+50kg Nha<sup>-1</sup> recorded the widest canopy spread of 56.78 and 56.17cm respectively (Table 2), however not significantly (p>0.05) different from other treated plots, while sole BX, INO+BX, sole INO and Control still recorded narrow canopy spread similar to the trend observed for plant height. At 10-14WAP the various fertilizers used as sole and the various combinations in two's or three's (INO, N-levels and BX) maintained high canopy spread while sole application of INO and Control recorded the lowest value all through.

**Table 2: Effect of Foliar fertilizer (BX), *Bradyrhizobium japonicum* (INO) and Nitrogen levels on soybean growth parameters**

Plant height (cm)

Canopy spread (cm)

Treatment (kg Nha <sup>-1</sup> )	WAP					WAP				
	6	8	10	12	14	6	8	10	12	14
25	31.60ab	48.47abc	57.97ab	597.7ab	638.3ab	49.67ab	52.22abc	67.13bcde	338.0abcd	325.0cde
50	29.80ab	47.40bc	60.33a	613.7ab	629.0ab	46.67bcd	50.94abc	73.73ab	390.0a	396.7a
75	29.77ab	49.23abc	53.80abc	555.3b	615.7ab	50.73ab	51.00abc	63.07e	326.7bcde	332.7bcde
BX	23.23c	37.67e	48.27bcd	413.0d	464.0d	41.47e	43.00de	69.27abcde	341.7abcd	352.0abcd
INO	22.80c	37.23e	41.70d	449.0cd	506.3cd	42.00cde	40.74e	70.73abcd	294.0de	309.0de
INO+25	29.45b	46.57cd	54.77ab	556.0b	604.3ab	47.80ab	48.00bcde	67.07bcde	306.7cde	333.7bcde
INO+50	32.57ab	52.40abc	62.87a	643.0ab	668.3ab	51.27ab	56.17a	76.73a	374.0ab	379.7 ab
INO+75	30.43ab	52.00abc	57.67ab	602.7ab	659.3ab	49.40ab	53.94ab	72.47abc	370.7ab	368.0ab
INO+BX	22.82c	37.13e	47.40bcd	413.0d	464.3d	39.80e	45.00cde	65.47cde	332.3abcd	332.0bcde
25+BX	30.67ab	48.37abc	54.13abc	549.3bc	592.7bc	50.47ab	48.61bcd	69.87abcde	342.0abcd	350.7abcd
50+BX	33.38a	54.00a	65.10a	659.3a	691.3a	49.07ab	56.78a	70.80abcd	345.0abcd	354.3abcd
75+BX	30.77ab	51.10abc	54.97ab	545.7bc	656.3ab	49.60ab	52.44ab	68.47bcde	340.3abcd	349.0abcd
INO+25+BX	32.00ab	50.33abc	60.07a	614.7ab	670.3ab	51.13ab	53.33ab	72.13abc	364.3abc	371.7ab
INO+50+BX	30.88ab	50.03abc	60.70a	623.3ab	656.7ab	48.40ab	52.61ab	67.20bcde	349.3abcd	355.0abcd
INO+75+BX	31.07ab	53.50ab	58.57ab	607.7ab	682.0ab	53.20a	54.00ab	70.80abcd	356.0abc	367.0ab
CONTROL	24.72c	40.00de	42.97cd	430.7d	472.0d	42.80cde	43.11de	64.53de	272.3e	290.3e
%CV	7.6	8.4	12.6	10.9	9.6	6.3	8.8	6.5	10.4	9.1

### 3.3. Effect of Foliar fertilizer (BX), Inoculation and Nitrogen levels on soybean growth

The application of INO+75kg Nha<sup>-1</sup>+BX resulted in the highest nodule number though not significantly (P>0.05) different from nodule gotten from other treated plots and the control except for 75kg Nha<sup>-1</sup> and 25kg Nha<sup>-1</sup>+BX). The highest nodule dry weight was recorded from plot treated with INO+75kg Nha<sup>-1</sup> (1070 mg plant<sup>-1</sup>), followed by the application of INO+75kg Nha<sup>-1</sup>+BX, INO+25kg Nha<sup>-1</sup>+BX and sole Inoculation. Also the highest biomass weight was recorded from plot treated with INO+75kg Nha<sup>-1</sup>+BX (4613 kg ha<sup>-1</sup>) followed by INO+25kg Nha<sup>-1</sup>+BX and INO+75kg Nha<sup>-1</sup> (4580 and 4556 kg ha<sup>-1</sup>) respectively, and were significantly at par with biomass from all other plots with treatment

combinations except for INO+BX (2418 kg ha<sup>-1</sup>). The use of sole INO, BX and Control performed at par with sole application of all the treatments used. Similarly the application of INO+75kg Nha<sup>-1</sup>+BX and INO+50kg Nha<sup>-1</sup>+BX gave the highest pod number (2.93 plant<sup>-1</sup>) each, which were not significantly different from the values gotten from the treatment combinations with the lowest level of N (INO+25kg Nha<sup>-1</sup>+BX), sole 25kg Nha<sup>-1</sup>, BX, INO, INO+BX and INO+75kg Nha<sup>-1</sup> (Table 3). The control recorded the lowest pod number (2.50 plant<sup>-1</sup>). In the same trend the highest pod weight was recorded from plots treated with INO+75kg Nha<sup>-1</sup>+BX, followed by INO+50kg Nha<sup>-1</sup>+BX, however, were at par with INO+BX, INO+75kg Nha<sup>-1</sup>, 25kg Nha<sup>-1</sup>+BX, 25kg Nha<sup>-1</sup> and INO+25kg Nha<sup>-1</sup>+BX while the Control recorded the lowest pod weight in all (11.86 plant<sup>-1</sup>).

**Table 3: Effect of Foliar fertilizer (BX), *Bradyrhizobium japonicum* and Nitrogen levels on soybean growth parameters**

Treatment (Kg N ha <sup>-1</sup> )	Nod number plant <sup>-1</sup>	Nod weight (mg plant <sup>-1</sup> )	Biomass weight (kg ha <sup>-1</sup> )	Pod number tran plant <sup>-1</sup>	Pod weight (g plant <sup>-1</sup> )
25	1.98ab	570.0b	3190 bcd	2.87abc	22.22abc
50	2.06ab	523.3b	3089 bcd	2.67d	13.73cd
75	1.86b	430.0b	3778 ab	2.63d	15.08cd
BX	1.92ab	476.7b	2196 d	2.80abcd	23.17abc
INO	2.26ab	800.0ab	1866 d	2.77abcd	18.35bcd

INO+25	2.29ab	796.7ab	3618 abc	2.73bcd	17.42bcd
INO+50	2.18ab	760.0ab	3902 ab	2.70cd	17.15bcd
INO+75	2.35ab	1070.0a	4556 a	2.90ab	25.44ab
INO+BX	2.33ab	796.7ab	2418 cd	2.90ab	25.97ab
25+BX	1.83b	510.0b	3666 abc	2.73bcd	22.47abc
50+BX	2.12ab	543.3b	3711 abc	2.73bcd	17.49bcd
75+BX	1.96ab	553.3b	3727 abc	2.73bcd	18.87bcd
INO+25+BX	2.27ab	866.7ab	4580 a	2.77abcd	20.28abcd
INO+50+BX	2.23ab	576.7b	3903 ab	2.93a	29.23a
INO+75+BX	2.44a	883.3ab	4613 a	2.93a	30.23a
CONTROL	1.98ab	606.7ab	2449 cd	2.50d	11.86d
%CV	15.1	30	23	4.2	29.8

#### 4.4. Effect of foliar fertilizer (BX), *Bradyrhizobium japonicum* and Nitrogen levels on soybean grain yield and harvest characteristics

The highest grain yield of 3587 kg ha<sup>-1</sup> was recorded from the plot treated with 50kg Nha<sup>-1</sup>+BX, followed by INO+75kg Nha<sup>-1</sup>+BX, 75kg Nha<sup>-1</sup>+BX, INO+50kg Nha<sup>-1</sup>, BX, INO+25kg Nha<sup>-1</sup>, INO+25kg Nha<sup>-1</sup>+BX, 50kg Nha<sup>-1</sup> and INO+BX. With values ranging from 2729 – 3429 kg ha<sup>-1</sup> over the control (1853kg ha<sup>-1</sup>) which was at par with sole INO (1979kg ha<sup>-1</sup>). The highest hundred seed weight (HSW) was recorded on plots treated with 25kg Nha<sup>-1</sup>,

though at par with most treated plots, the control had the lowest HSW value in all (Table 4). The soybean haulm weight was highest on plots treated with INO+50kg Nha<sup>-1</sup>+BX (12.76 g plant<sup>-1</sup>) followed by INO+75kg Nha<sup>-1</sup>+BX (11.37 g plant<sup>-1</sup>) and INO+75kg Nha<sup>-1</sup> (9.25 g plant<sup>-1</sup>) while Control recorded the lowest value (4.53 g plant<sup>-1</sup>). Soybean husk weight was highest on plots with INO+50kg Nha<sup>-1</sup>+BX (9.93 g plant<sup>-1</sup>) followed by INO+75kg Nha<sup>-1</sup> (9.42 g plant<sup>-1</sup>) and INO+BX (9.39 g plant<sup>-1</sup>), though not significantly different from values recorded from other treated plots, again the Control had the lowest husk weight of 4.55 g plant<sup>-1</sup>.

**Table 4: Effect of Foliar fertilizer (BX), *Bradyrhizobium japonicum* and Nitrogen on soybean grain yield and harvest**

Treatment (kg Nha <sup>-1</sup> )	Grain yield (kg ha <sup>-1</sup> )	HSW	Husk weight (g plant <sup>-1</sup> )	Haulm weight (g plant <sup>-1</sup> )
25	2486abc	15.07a	7.46abc	8.19bcd
50	2738abc	13.63ab	6.14abc	5.72cd
75	2419bc	13.30b	6.45abc	6.73cd
BX	2969abc	13.87ab	8.28abc	5.82cd
INO	1979c	13.60ab	7.42abc	4.85cd
INO+25	2940abc	14.30ab	6.14abc	8.09bcd
INO+50	3172ab	13.50ab	6.16abc	7.22bcd
INO+75	2390bc	13.83ab	9.42ab	9.25abc
INO+BX	2729abc	14.07ab	9.39ab	6.93bcd
25+BX	2462abc	14.60ab	8.48abc	7.28bcd
50+BX	3587a	13.27b	7.09abc	6.56cd



75+BX	3214ab	14.43ab	5.66bc	6.85cd
INO+25+BX	2772abc	13.67ab	7.11abc	5.95cd
INO+50+BX	2525abc	14.00ab	9.93a	12.76a
INO+75+BX	3429ab	14.13ab	7.85abc	11.37ab
CONTROL	1853c	13.70ab	4.55c	4.53d
%CV	25.7	6.9	29.7	27.5

## DISCUSSION

It was evident from this study that early season vigorous growth needed for soybean development to boost grain production in the study area requires some level of soil amendment. The application of at least 25kg Nha<sup>-1</sup> cannot be underestimated, better still the top dressing (50kg Nha<sup>-1</sup>) with INO or BX and the combination of the three (50kg Nha<sup>-1</sup>+INO+BX) gave significant advantage to soybean plant height and canopy spread (Table 2). Meaning that indeed the mid vegetative application of N and foliar fertilizer enhanced soybean growth thereby giving room for prolonged and effective photosynthetic activities required for optimum plant growth and maturity. The response of soybean to the initial N application could be attributed to the low nutrient soil status of the study area (Table 1). More so research has recognized that initial nodulation takes time to develop and that significant N is not obtainable from N<sub>2</sub> – fixation until flowering begins. Similar to the findings in Alabama it was reported that N fertilization increased early-season soybean growth at five of seven locations however, the data were not conclusive. Also Wood *et al.*, (1993) reported that starter-N appeared to offer the greatest benefit to early growth and plant-N content in sites where soybean growth responses were observed. Sawyer (2001) also reported that: In some situations, preplanting N application has increased soybean yield. Often it occurs in sites with low inorganic-N supply, low soil organic matter, low residual soil nitrate. He also observed that soybean sometimes appear N deficient early in the growing season (light green color, reduced growth or small leaves) especially with reduced and no-tillage. However, when either available soil N increases or N<sub>2</sub>-fixation becomes more effective they recover. The Control plot recorded the lowest plant height and canopy spread values in all and was at par in most cases with sole INO and BX. No wonder the response of soybean to Control, Inoculation and BX (plant height and canopy spread) were at par all through the experiment (Table 2) except for canopy spread response to BX which later picked up at the 10 to 14<sup>th</sup> weeks and eventually positively influenced the grain yield. Literature have reported that foliar fertilizer provides more rapid utilization of nutrients and

permits the correction of observed deficiency symptoms in less time than would be required by soil application (Fageria *et al.*, 2009). Contrary to soybean canopy spread response to sole use of Inoculant which was narrow until the peak of flowering (10<sup>th</sup> week) and was almost immediately retarded again possibly due to leaf senescence, which confirms that there is need for additional nutrient supplement at this growth stage for soybean sustenance. Likewise, several reports have affirmed that the success of inoculation depends not only on high quality inoculants and good inoculation practices but also on the establishment of effective and efficient BNF through optimization of the factors that affect its performance such as legume genotype, climatic, edaphic and management factors (Giller, 2001; Giller and Wilson, 1991; Sanginga *et al.*, 1995).

Response of soybean nodulation to applied treatments (Table 3) cannot be attributed to split application of N (50 and 75kg Nha<sup>-1</sup>) and foliar fertilizer because nodule assessment was done at soybean 50% flowering, just before the split application of N and foliar fertilizer. The nodule number for the treated plots and Control were significantly (P<0.05) at par, this agrees with several workers who recommend N fertilization of soybean at small amounts at the early stage as a starter, especially in N deficient soils that improves growth and subsequently yield but may reduce nodulation (Osborne and Riedell, 2006; Pikul *et al.*, 2001).

After all controversial reports about the negative and positive effects of N fertilizer use on soybean nodulation has been affirmed especially with high level of N use. This study support the use of 25kg Nha<sup>-1</sup> as it was observed to be sufficient for inoculated soybean successful germination and establishment in the study area. Similarly, Emam *et al.*, 2014 reported that the presence of N in the soil as a starter dose (60kg per hectare) with a *Bradyrhizobium japonicum* bacteria positively affect nodule dry weight per plant and nitrogenase activity. The inoculation of soybean with *Bradyrhizobium japonicum* inoculant with or without N and foliar fertilizer resulted in about 25% and above nodule dry weight increase as against the Control. Indicating that the introduced strains were compatible with the

indigenous strains especially with the initial application of 25kg N ha<sup>-1</sup> thereby aggravated substantial level of increase in nodule dry weight. As affirmed by Fatima *et al* (2007) who reported that nodule formation and its nitrogen fixation activity by *B. japonicum* is dependent on the presence of a compatible strain in a soil for a particular soybean variety. Moreso that the sole use of inoculation and control plot revealed that soybean growth cannot be sustained by inoculation only and the indigenous strains (Control) were not also effective in the study area. Likewise the biomass yield at 50% flowering followed the same trend with the nodule weight and therefore can be induced that the combination of 25kg N ha<sup>-1</sup>+INO enhanced the vegetative growth of soybean as was observed by some researchers. Gertenbach and Dugmore (2004) reported that Crop biomass yield is affected by the same factors that affect crop yield. According to Adediran *et al.*, (2015), N being an important constituents of nucleotides, proteins, chlorophyll and enzymes, is involved in various metabolic processes and has direct impact on vegetative and reproductive phases of plants. Again the sole use of *Bradyrhizobium japonicum* inoculant, sole foliar fertilizer (BX) and control recorded the lowest biomass dry weight meaning that inoculation alone is not able to sustain soybean development and the soybean plant also required some nutrients at the early growth stage before foliar fertilizer application was done.

Pod formation could be explained with regards to all the used fertilizer sources, because the parameter was taken after the split application of N and foliar fertilizer. The statistical mean value shows that the use of sole 25kg N ha<sup>-1</sup>, BX and their combinations was positively responded to by inoculated soybean pod number and weight at the same level of significance, however the combinations with supplemented fertilizer application (50, 75 and BX) had slight increase of pod number and weight over the sole applications of the fertilizers used. Similar Lambon (2016) reported that the higher levels of N fertilizer levels (45kg N) produced ha<sup>-1</sup> significantly higher pod numbers than the 15 and the 0kg N in the same study area. This is similar to earlier research findings (Umeh *et al.*, 2011; Diep *et al.*, 2002; Chemining' wa *et al.*, 2012). It was also observed that sole application of 25kg N ha<sup>-1</sup>, BX, INO, 25kg N ha<sup>-1</sup>+ BX and INO+BX had pod number and pod weight significantly ( $P<0.05$ ) at par with the combinations of 25kg N ha<sup>-1</sup>+INO+BX, 50kg N ha<sup>-1</sup>+INO+BX and 75kg N ha<sup>-1</sup>+INO+BX, while the Control recorded the least in all. These are positive indications of soybean response to N fertilizer application, which is in line with the works of other researchers (Umeh *et al.*, 2011; Diep *et al.*, 2002). It

has also been pointed out that leaves and stems are the major contributors to N supply to the seeds, while N from the pods constitute a temporary reserve for seed filling (Pate, 1985; Peoples and Dalling, 1988). They indicated that, pods are closer to the developing seed and are first to supply the seed with N but this supply ceases shortly in a couple of weeks. However, the response of crop to foliar fertilizer application rapidly reflects in 3 - 4 days while nutrients applied to the soil takes five to six days (Fageria *et al.*, 2009). The authors further reported that foliar fertilizer supplement soil fertilization because nutrients penetrate the cuticle of the leaf or the stomata and then into the cells more readily. It also confirms an earlier report by Fageria *et al.* (1997) that legume grains yield is a function of number of pods per plant. Sole BX recorded 19%, 50% and 60% over sole 25kg N ha<sup>-1</sup>, INO and Control. Which is an indication that the use of foliar fertilizer just as been reported by some researchers has the tendency to enhance the growth and especially the grain yield of soybean. This possibly could lend credence to the fact that the foliar fertilizer contains some level of micro and macro nutrients which could have been made available to the plant as at when needed. Fageria *et al.*, (2009) reported that foliar fertilizer supplement soil fertilization because nutrients penetrate the cuticle of the leaf or the stomata and then into the cells more readily. This rate of ion passage through the cuticle and the epidermal tissues of the leaves depend on many factors such as the concentration, physical and chemical properties of the sprayed ion and micronutrients which are needed in limited quantities (Fageria *et al.*, 2009). Furthermore, to reduce fertilizer application to soil, new formulations of foliar fertilizer (micro- or macro-nutrients or both) are available worldwide and could be more effective than soil applied fertilizer in reducing effect of nutrient Deficiencies on BNF (Zahran, 1999). Oko *et al.* (2003) reported that foliar application of urea increased soybean grain yield; between 6 and 68% higher than the Control. Moreover, the effect of foliar fertilization on grain yield according to Mallarino *et al* (2001) depends upon the application period of the different growth stages of soybean. It is also most successful for supplying micronutrients, and more effective and economical because some of the nutrients, such as iron, are easily immobilized in the soil (Fageria *et al.*, 2009). The highest grain yield was recorded by soybean on 50Kg N ha<sup>-1</sup>+BX plot with 45%, 31%, 22%, 21% and 44% over 25kg N ha<sup>-1</sup>+BX, INO+BX, INO+25kg N ha<sup>-1</sup>, BX and 25kg N ha<sup>-1</sup> respectively with 93% significance over the Control, it was also realized by Lambon (2016) that in 2012 at Nyankpala, the 45kg N yielded the highest ha<sup>-1</sup> grain of 2146 kg, however the application of



50kg N ha<sup>-1</sup>+BX and INO+50 (3587 and 3172 kg ha<sup>-1</sup>) in the same study area gave 1000 and above grain yield advantage over Lambon's report. Meaning that indeed the additional fertilizer supplement added at mid-vegetative till early podding stage of soybean development serve as a nutrient source which sustain soybean through reproductive stage when the nodules are assumed to have ruptured for efficient pod formation and seed filling (Nutrient sink). According to Chaturvedi (2005) nitrogen nutrition influences the content of photosynthetic pigments, the synthesis of the enzymes taking part in the carbon reduction and the formation of the membrane system of chloroplast. The sole and combinations of all the treatments (BX, INO, and N- level) performed better than the Control, except sole INO which had just 7% increase over the Control, infact the least produced treatment (INO+75kg Nha<sup>-1</sup>) recorded close to 30% increase over the Control. Lending credence to the fact that indeed there is need for the application of fertilizer (BX, INO, N-Levels) and especially the top dressing of N to give 50kg N ha<sup>-1</sup> and the application of foliar fertilizer at mid-vegetative stage till early podding stage for soybean sustenance till maturity, however the choice of fertilizer to adopt is left to the farmer with regards to the availability of the resources and his financial capability.

#### Conclusion and Recommendation:

The use of various sources of fertilizer, indeed contributed positively to the performance of soybean in the study area, meaning that the soil actually required some level of fertilizer supplement to enhance soybean cultivation. Response of soybean growth and yield to the various fertilizer combinations leaves the farmer with a whole lot of choice to make depending on his financial ability to purchase the required fertilizer. It was glaring that soybean indeed requires complementary application of fertilizer at the mid vegetative – early pod filling stage, however the highest produced treatment (50kg Nha<sup>-1</sup>+BX) performed significantly at par with some of the other treated plots such as the other levels of N+BX, the N-levels+INO, the N-levels+INO+BX and even some sole application of fertilizer. Hence, the highest grain yielded plot (50kg Nha<sup>-1</sup>+BX) recorded 20% and above grain yield increase compared to sole BX, INO+25kg Nha<sup>-1</sup>, INO+BX and INO+25kg Nha<sup>-1</sup>+BX but with close to 100% grain yield increase over the control. While the use of sole BX, INO+25kg Nha<sup>-1</sup>, INO+BX and INO+25kg Nha<sup>-1</sup>+BX recorded at least 60, 59, 47 and 50% grain yield increase over the control respectively, hence can also be adopted depending on the farmers choice.

#### References

1. Araujo, R.S., Robleto, E.A., Handelsman, J. (1994). A hydrophobic mutant of *Rhizobium etli* altered in nodulation competitiveness and growth in the rhizosphere. *App. J. Environ. Microbiol.* 60: 1430-1436.
2. Ashour, N. I. and Thalloth, A. T. (1983). Effects of soil and foliar application of N during pod development and yield of soybean (*Glycine max.* (L) Merrill) plants. *Field Crops Research* 6: 261 - 266.
3. Bellaloui, N., Bruns, H. A. , Gillen, A. M., Abbas, H. K., Zablotowicz, R. M., Mengistu, A. and Paris, R. L. (2010). Soybean seed protein, oil, Fatty Acids, and Mineral Composition as influenced by Soybean-Corn Rotation. *Agricultural Sciences*, 1: 102 - 109. <http://dx.doi.org/10.4236/as.2010.13013>
4. Boote, K. J., Gallaher, R. N., Robertson, W. K. Hinson, K. and Hammond, L.C. (1978). Effect of foliar fertilization on photosynthesis, leaf nutrition, and yield of soybean. *Agronomy Journal* 70: 787 – 791.
5. Bouyoucos, G. J. (1936). Directions for making mechanical analysis of soils by the hydrometer method. *Soil Sci.* 42(3).
6. Bray, R. H. and Kurtz, L. T. (1945). Determination of total, organic and available forms of phosphorus in soils. *Soil Sci.* 59: 39 - 46.
7. Bremner, J. M. And Mulvaney, C. S. (1982). Nitrogen-total, in methods of soil analysis. Page, A. L. (ed). *Methods of soil analysis.* Agronomy Monography 9. American Society of Agronomy. Madison, WI. pp. 595 - 624.
8. Chemining'wa George, N., Ngeno, J., Muthomi, J. W. and Shabbairo, S. I (2012). Effectiveness of Indigenous pea Rhizobia (*Rhizobium leguminosarum* bv.viciae) in cultivated soils of central Kenya. *Journal of Applied Biosciences* 57: 4177-4185.
9. Chen, Z., Mackenzie, A. F., Fanous M. A. (1992). Soybean nodulation and grain yield as influenced by N - fertilizer rate, plant population density and cultivar in South Quebec. *Can. J. Plant Sci.* 72: 1049 - 1056.
10. Diep, C. N., Daug, H. V., Ngau, V. N., Son, T. M and Duong, P. T. (2002). Effects of rhizobial Inoculation and Inorganic N fertilizer on Vegetable Soybean (*Glycine Max* [L] Merr.) cultivated on Alluvial soil of Cantho province (Mekong delta) using 15N



- Isotope Dilution Technique. ACIAR Proc. 109e and edited by D. Herridge.
11. **Dorivar, R. D. (2009).** Fertility management in Soybean, soil fertility and nutrient management. Extension Agronomy Kansas State University. [www.agronomy.ksu.edu/extension/soil\\_fertility](http://www.agronomy.ksu.edu/extension/soil_fertility).
  12. **Ezekiel-Adewoyin D. T. (2014).** Evaluation of the growth response of soybean (*glycine max* L.) to some commercial fertilizers in the Guinea Savannah agro - ecological zone of Ghana. PhD. Thesis submitted to the Crop and Soil Sciences Department of the Faculty of Agriculture, KNUST, Kumasi, Ghana.
  13. **Fageria N. K., Barbosa F. M. P., Moreira A. and Guimarães C. M. (2009).** Foliar fertilization of crop plants. *J. Plant Nutri.* 32:1044–1064.
  14. **Fageria, N. K., Filho, M. P. B., Moreirab, A. and Guimaresa, C. M. (2009).** Foliar fertilization of crop plants. *J. Plant Nutr.* 32 (6): 1044 – 1064.
  15. **FAO. (1988).** *Soil Map of the World. Revised Legend.* Reprinted with corrections. World Soil Resources Report 60. FAO, Rome.
  16. **Fatima, .Z, Zia M., Chaudhary, M. F. (2007).** Interactive effect of Rhizobium strains and P on soybean yield, nitrogen fixation and soil fertility. *Pak J. Bot.* 2007;39:255-264.
  17. **Garcia, L. and Hanway, J. J. (1976).** Foliar fertilization of soybeans during the seed-filling period, *Agron, J.* 68: (1976). pp. 653 – 657.
  18. **GenStat, (2007).** GenStat for windows (GenStat 9<sup>th</sup>) edition. Lawes Agricultural trust, Rothamsted experimental station. UK.
  19. **Gertenbach, W. D. and Dugmore, T. J. (2004).** Crop Residues for Animal feeding. *SA-ANIM. SCI.* Vol. 5 ( [www.sasas.co.za/Popular/Popular.html](http://www.sasas.co.za/Popular/Popular.html)).
  20. **Giller K. E. (2001).** Nitrogen fixation in tropical cropping systems. 2<sup>nd</sup> edn. Wallingford, United Kingdom, CAB International. 423 pp.
  21. **Giller K. E. and Wilson K. J. (1991).** Nitrogen fixation in tropical cropping systems. CAB International, Wallingford, UK.
  22. **Hartwig, E.E. (1973).** **Varietal development.** In. B.E. Caldwell (ed), Soybeans: improvement production and Uses. *Agronomy* 16: 187 - 210.
  23. **Helmke, P. A. and Sparks, D. L. (1996).** Methods of Soil Analysis. Part 3. Chemical Methods – Soil Science Society of America. Book series no. 5. Madison, Wisconsin, USA.
  24. **Keyser, H. H. and Li, F. (1992).** Potential for increasing biological nitrogen fixation in soybeans. *Plant and Soil* 141: 119 - 135.
  25. **Lambon, J. B. (2016).** Inoculation and n fertilizer effects on the growth, grain yield and n remobilization in soybean (*glycine max* [L] merrill) in the Guinea Savanna zone of Ghana. PhD. Thesis submitted to the Crop and Soil Sciences Department of the Faculty of Agriculture, KNUST, Kumasi, Ghana.
  26. **Mallarino, A. P., Haq, M. U., Wittry, D. and Bermudez, M. (2001).** Variation in soybean response to early season foliar fertilization among and within fields. *Agronomy Journal* 93: 1220 – 1226.
  27. **Nelson, D. W. and Sommers, L. W. (1982).** Total carbon, organic carbon and organic matter. In: A. L. Page et al. (eds.). *Methods of soil analysis. Part 2.* Second edition. Chemical and microbiological properties. American Society of Agronomy and Soil Science Society of America. Madison, Wisconsin USA. pp. 301 - 312.
  28. **Osborne, S. L. and Riedell, W. E. (2006).** Starter Nitrogen Fertilization Impact on Soybean Yield and Quality in the Northern Great Plains. *Agron. J.* 98:1569-1574.
  29. **Otieno, P. E., Muthomi, J. W., Chemining'wa, G. N. and Nderitu, J. H. (2009).** Effect of rhizobia inoculation, farm yard manure and nitrogen fertilizer on nodulation and yield of food grain legumes. *Journal of Biological Sciences* 9(4): 326 - 332.
  30. **Parker, M. B. and F. C. Boswell. (1980).** Foliar injury, nutrient intake, and yield of soybean as influenced by foliar fertilization. *Agronomy Journal* 72: 110 – 113.
  31. **Pate, J.S. (1985).** Physiology of pea. A comparison with other legumes in terms of economy of carbon and nitrogen in whole plant and organ function. In PD Hebblewaite , M.c, heath, T.C.K Dawkins, eds, the pea crop. Butterworths, London. Pp 279-296.
  32. **Peoples, M. B. and Dalling, M. J. (1988).** The interplay between proteolysis and amino acid metabolism during senescence and nitrogen reallocation. In: Noodén LD, Leopold AC, eds. *Senescence and aging in plants.* San Diego, CA, USA: Academic Press, 181–217.
  33. **Peoples, M. B. Herridge, D. F. and Ladha, J. K. (1995).** Biological

nitrogen fixation: an efficient source of nitrogen for sustainable agricultural production. *Plant and soil*, 174: 2 - 28.

34. **Rathke, G. W., Christen, O. and Diepenbrock. (2005).** Effects of nitrogen source and rate on productivity and quality of winter oilseed rape (*Brassica napus* L.) grown in different crop rotations. *Field Crops Research*, 94: 103 – 105.
35. **Ross J. R., Slaton N. A., Brye K. R., DeLong R. E. (2006).** Boron fertilization influences on soybean yield and leaf and seed boron concentrations. *Agron. J.* 98, 198–205 10.2134/agronj2005-0131.
36. **Sanginga, N., Valanwe, B. and Danso, S. K. A. (1995).** Management of biological N<sub>2</sub> fixation in alley cropping system. Estimation and contribution to N balances. *Plant and Soil* 174:11-141.
37. **SARI. (2009).** Soybean a production guide for northern Ghana.
38. **Sawyer, J. E. and Barker, D. (2001).** In-season Nitrogen Fertilization of Soybean. p. 158-161. In Proc. Thirty First North Central Extension- Industry Soil Fertility Conf., Des Moines, IA. 14-15 Nov. 2001. Potash and Phosphate Inst., Brookings, SD.
39. **Startling, M. E., Wood, C. W. and Weaver, D. B. (1998).** Starter Nitrogen and Growth Habit Effects on Late-planted Soybean. *Agronomy J.* 90: 658- 662.
40. **Thies, J. E., Singleton, P. W. and Bohlool, B. B. (1991).** Influence of the size of indigenous rhizobial population on establishment and symbiotic performance of introduced rhizobia on field-grown legumes. *Applied and Environmental Microbiology* 38: 493 – 500.
41. **Umeh, M. O, Edeoga, H. O. and Omosun, G. (2011).** Nitrogen Fertilizer Type and Rate Effects on Growth and Yield Response of Soybean Varieties. *Continental J. Agronomy* 5 (2): 1 – 8.
42. **Van kessel, C and Hartley, C. (2000).** Agricultural management of grain legumes: has it led to an increase in nitrogen fixation. *Field crops research* 65:165 - 181.
43. **Wesley, T. L., Lamond, R. E., Martin, V. L. and Duncan, S. R. (1998).** Effects of late-season nitrogen fertilizer on irrigated soybean yield and composition. *J. Prod. Agric.* 11:331 - 336.
44. **Wood, C. W., Torbert, H. A and Weaver, D. B. (1993).** Nitrogen Fertilizer Effects on Soybean Growth, Yield, and Seed Composition. *J. Production Agric.* 6:354-360.
45. **Woomer, P. L., Martin, A. Albrecht, D. V. S. Resek and Scharpenseel. (1994).** The importance and management of soil organic matter in the tropics. Pp 47-80. *In: The biological management of the soil fertility* (eds.): Woomer, P. L. and Swift, M. J. Swift. Chichester UK John Wiley and Sons.
46. **Zahran H. H. (1999).** Rhizobium-legume symbiosis and nitrogen fixation under severe conditions and in an arid climate. *Microbiol. Mol. Biol. Rev.* 63:968–989.

# ADOPTION OF SOIL HEALTH PRACTICES BY SMALL-SCALE FARMERS IN NIGER STATE, NIGERIA

Tsado, J. H<sup>1</sup>., Olaleye, R. S<sup>1</sup>., Tyabo, I. S<sup>1</sup>., Mohammed, Y<sup>1</sup>., Agwo, K<sup>1</sup>. and E. Mamman<sup>2</sup>

Department of Agricultural Extension and Rural Development <sup>1</sup>

Department of Production <sup>2</sup>

Federal University of Technology, Minna, Niger State, Nigeria.

\* Email: [jacobtsado2007@yahoo.com](mailto:jacobtsado2007@yahoo.com) 08065268098

## ABSTRACT

*Farmers require demonstrable knowledge, skills, behaviour and attitude to enable them adopt new technologies at a certain performance standard. This concern gave rise to this study with specific objectives to determine farmers' awareness, perceived level of competence, factors affecting their adoption of soil health practices and the constraints faced in the adoption process. 120 respondents were selected for the study through simple random sampling. Data were collected through questionnaire/ interview schedule and analyzed using descriptive and inferential statistics. All of the respondents claimed to be aware of all the soil health practices under consideration except contour bounds/terracing/wind breaks (79%). The most adopted soil health practices among farmers were crop rotation (100%), increase in organic matter input (90.83%) and use of cover crops/mulching (82.50%) which ranked 1<sup>st</sup>, 2<sup>nd</sup> and 3<sup>rd</sup> respectively. The farmers' claimed to be competent in practicing increase in organic matter input (4.10), crop rotation (4.02) and in the use of cover crops/mulching (3.98). However, the most important factors affecting the adoption of soil health practices which showed a significant relationship were age of the farmer (-2.02), gender (1.81), income of the farmer (1.69 ) and access to credit (2.07), statistically related to adoption of soil health practices at  $p < 0.05$  and  $p < 0.10$ . The study findings shows that farmers in the study area have positive attitude towards the adoption of soil health practices which can be improved upon via training and provision of credits facilities to empower them and to facilitate the adoption process.*

**KEYWORDS:** Farmer, Adoption, Soil health, Practices

## INTRODUCTION

Soil is a critical resource; the way in which it is managed can improve or degrade the quality of that resource. Soil is a complex ecosystem where living microorganisms and plant roots bind mineral particles and organic matter together into a dynamic structure that regulates water, air and nutrients). In an agricultural context, soil health most often refers to the ability of the soil to sustain agricultural productivity and protect environmental resources. A healthy soil provides many functions that support plant growth, including nutrient cycling, biological control of pests, and regulation of water and air supply. These functions are influenced by the inter-related physical, chemical and biological properties of soil, many of which are sensitive to soil management practice. Healthy soil is the foundation for profitable, productive and environmentally sound agricultural systems. By understanding how the soil processes that support plant growth and regulate environmental quality are affected by management practices, it is possible to design a crop and soil management system that improves and maintains soil health over time (white and Barbercheck, 2012 and Arbuckle, 2012)

According to Carlisle (2015) and Bergtold *et al.*(2012), Soil health practices such as crop rotation, conservation of tillage and cover cropping provide synergistic environmental and economic benefits, both on and beyond the farms where these practices are adopted for example, cover crops, non-harvested crops planted in the off season to improve soil health –offer large scale environment benefit by sequestering carbon, reducing soil erosion, preventing nutrient leaching, and providing habitat for beneficial insects and pollinators, but they can also benefit farmers by boosting soil productivity and from time to time crop yields, suppressing weeds, reducing fertilizer needs and improving nutrient cycling). Similarly, conservation tillage which is a method of tillage that leaves residues from the previous crop on the field reduces erosion while also boosting soil productivity and often lowering farmers labour and diesel costs (Fuglie, 1999 as cited by Carlisle, 2015). Crop rotation promotes ecological diversity as well as economic diversity which can help protect farmers against volatility in both climatic and market terms (Carlisle, 2015). Given these well-established economic and environmental benefits, researchers have been puzzled by the persistent adoption gap for these practices in U.S commodity agriculture (Canales *et al.*, 2015). Just 12% of Iowa



producers use cover crops (Arbuckle, 2012), while only 21% of U.S corn acreage is managed with zero tillage, known to farmers as no till (Canales, 2015). Multiple studies have attempted to shed more light on why farmers do or do not use soil health practices, in an attempt to better understand and eliminate this adoption gap.

Majority of the farmers in the study area have not adopted the soil health practices as a result most of the soil are depleted and as such could not give crop yield as expected. The inability of the farmers to adopt these soil health practices may be attributed to lack of awareness and adequate knowledge on their part of the importance of adoption of soil health practices to improve the soil characteristics like the soil structure, soil consistency and cation exchange capacity, despite the advantages of soil health practices, it is still in its nascent stage as only few hectares of land are under soil health practices.

The study therefore ascertain the level of awareness and adoption of soil health practices by small-scale farmers, examine their perceived competence in the adoption of soil health practiced, determine the factors affecting the adoption of the soil health practices and the constraints encountered in the adoption of soil health practices.

## METHODOLOGY

The study was conducted in paikoro and Bosso Local Government Area of Niger state, Nigeria, Agriculture is the mainstay of the economy of the state as much as 80% of the state depends on it, crops grown in the study area includes; Yam, maize, cowpea, rice etc, animals reared include cattle goat and sheep. Primary data was used for this study, it was collected through the administration of questionnaires and structured interview schedule. Multi stage sampling technique was adopted for this study. Bosso and Paikoro local government areas were randomly selected, the second stage involved random selection of 3 extension cells from the 2 extension blocks of the local Government areas, 2 villages were also randomly selected from each cell and 10 respondents randomly selected from each village making a total of 120 respondents from the two local government areas. Data were analyzed through the use of descriptive Statistics such as frequency counts, percentages and means and Inferential statistics, Poisson regression model was used to determine the factors affecting the adoption of soil health practices. The implicit form of the model is as stated below

$$Y = f(X_1, X_2, X_3, X_4, \dots, X_{11})$$

The functional form is expressed in the explicit form as

$$Y = b_0 + b_1X_1 + b_2X_2 + b_3X_3 + b_4X_4 + b_5X_5 + b_6X_6 + b_7X_7 + b_8X_8 + b_9X_9 + b_{10}X_{10} + b_{11}X_{11} + e$$

Y = Adoption-(number of health practices adopted)

X<sub>1</sub> = Age of the farmer (year)

X<sub>2</sub> = Gender of the farmer (Male/Female)

X<sub>3</sub> = Marital status (Single/Married)

X<sub>4</sub> = household size (number of members in the family)

X<sub>5</sub> = educational level (pri-1,sec-2,tertiary-3)

X<sub>6</sub> = Farm size (hectare)

X<sub>7</sub> = Income (₦)

X<sub>8</sub> = Cooperatives (number of cooperatives)

X<sub>9</sub> = Access to credit (₦)

X<sub>10</sub> = Access to training (number of times)

X<sub>11</sub> = Farm distance (Km)

For the perceived competence of the farmers in the adoption of soil health practices and the constraints faced, 5-point rating scale were used: very competent (5 points), competent (4 points), not sure (3 points), fairly competent (2 points) and not competent (1 point) and very serious (5 points), serious (4 points), not sure (3 points), not serious (2 points) not a constraint (1 point) for perceived competence and constraints, respectively. The scores were weighed and weighted average found as used by (Odinwa *et al.*, 2011). The critical mean 3.0 derived from 5-point likert rating scale (5+4+3+2+1/5) was used to describe farmers' competence and constraints. The competence and constraints scores greater than or equal to critical mean of 3.0 depicts high competent and serious constraint, respectively.

## RESULTS AND DISCUSSION

### Farmer's awareness and adoption of soil health practices

The result in Table 1 revealed that the respondents were aware of all the soil health practices, implying that the awareness level of the respondents was high; majority of the respondents had also tried the various soil health practices. The most adopted practices however, were crop rotation (100%), increase in organic matter input (90.83%) and use of cover crops (87.50%). The low adoption rate could be attributed

to various reasons such as problem of land tenure system, financial barrier, natural disasters etc. this findings is in agreement with that of Carolan (2005), who stated that land renters were more reluctant to make long-term investments in land they may not farm for very long; they are also hesitant to “rock the boat” with landlords by suggesting conservation practices, fearful of jeopardizing their tenancy.

#### **Farmers perceived level of competence in adopting soil health practices**

The entries in Table 2 revealed respondents perceived level of competence in the adoption of soil health practices. The respondents competence were said to be high for the following soil health practices: increase in organic matter content of the soil ( $\chi = 4.10$ ), crop rotation ( $\chi = 4.02$ ) and use of cover cropping ( $\chi = 3.98$ ), these practices were said to be more compatible with the small scale farmers cultural practices and it is often believed that farmers accept and adopt new technologies that are compatible with their cultural practices more rapidly, This is in agreement with the findings of Stivers-young (1999) and Snapp (2005) that farmers readily adopt cover cropping for protecting and improving the nutrient status of the soil.

#### **Factors affecting the adoption of soil health practices**

Out of eleven independent variables as shown in Table 3 age, gender, marital status, income and access to credit were found to be statistically significant and were positively related to adoption, however, age was negatively related to adoption, this implies that an increase in age of the respondent will lead to a decrease in adoption, this is in line with the prior expectation, a unit increase in the number of small scale farmers age will lead to a decrease in the adoption of soil health practice. A unite increase in credit will lead to increase in adoption rate of soil health practices. This is in agreement with the report of Mohammed and Temu, (2008) and Simitowe and Zeller (2006) that access to credit promotes the adoption of technologies. The result of the regression analysis shows an  $R^2$  value of 0.3186. This implies that the independent variables only explained 32% of the factor affecting adoption of soil health practices included in the model while the remaining 68% is error of non-inclusion of some explanatory variables. The model LR (11) value of 26.23 was statistically significant at 5% level of probability which is an indication that the model is good.

#### **Perceived constraints to the adoption of soil health practices**

The result in Table 4 revealed that the respondents faced enormous problems in adopting soil health practices, among this problems inadequate credit facility ( $\chi=3.40$ ), inadequate information on soil health practices ( $\chi=3.35$ ) and lack of training ( $\chi=3.30$ ) ranked high and as such were the most severed constraints faced by the small scale farmers. These three major constraints are fundamental and very critical in any technology dissemination and adoption, This agrees with the findings of Muzari *et al.* (2013), that lack of training skills and inadequate information on soil health practices were very severe constraints, except for inadequate credit facilities.

#### **CONCLUSION AND RECOMMENDATIONS**

From the study it can be concluded that the level of awareness of soil health practices of the farmers were high however, the level of adoption of the practices were low. The farmers therefore need more training in the areas of monitoring soil performance and how to reduce pesticides use for providing good habitat for beneficial organisms; age had a significant influence but was negatively related to adoption. It is recommended that Government, NGOs and sister agencies should provide a platform for training farmers on soil health practices and provide credit either in cash or input materials to help in facilitating the adoption of soil health practices to boast small scale farmers' productivity.

Table 1: Farmers awareness and adoption of soil health practices

Soil health practices	Aware (%)	Tried (%)	Adopted (%)
Reduce inverse tillage and soil traffic	100	60.83	58.33
Increase in organic matter input	100	94.16	90.83
use of cover crops/mulching	100	87.50	82.50
Reduce pesticide use and provide habitat for beneficial organism	100	87.5	76.67
Crop rotation	100	100	100.00
Nutrient Management	79	49.75	42.50
Monitoring soil performance	100	75.83	68.33

Source: Field survey, 2017

Table 2: Farmers perceived level of competence in adopting soil health practices

Soil health practices	Weighted score	Weight mean ( $\chi$ )	Remark
Reduce inverse tillage and soil traffic	245	2.04*	Low
Increase in organic matter input	493	4.10**	High
use of cover crops/mulching	478	3.98**	High
Reduce pesticide use and provide habitat for beneficial organism	195	1.63*	Low
Crop rotation	482	4.02**	High
Nutrient Management	234	1.95*	Low
Monitoring soil performance	213	1.78*	Low
<b>Total (<math>\chi</math>)</b>		<b>19.50</b>	
<b>Critical mean</b>	$\geq 3.0 = **$		
	$< 3.0 = *$		

Source: Field survey, 2017

Table 3: Factors affecting the adoption of soil health practices

Variables	Coefficient	Standard error	Z	P> (z)	Source: Field survey, 2017
Age	-.1098022	.054266	- 2.02**	0.043	
Sex	2.128872	1.235826	1.72*	0.085	
Marital status	.0314056	.0843411	1.81*	0.070	
Household size	0.314056	.0843411	0.37	0.710	
education	-.1096645	.2141907	-0.51	0.609	
Farm size	.000745	.3392383	0.00	0.998	
income	.0000188	0000111	1.69*	0.091	
Cooperative	-.0432197	.9318335	0.05	0.964	
Access Credit	3.144377	1.521135	2.07**	0.039	
Access to Extension	.3103297	2.332075	0.13	0.894	
Farm distance	-.0432197	.1571294	-0.28	0.783	
Log Likelihood = -28.047					
Observation =120					
LR chi <sup>2</sup> = 26.23					
Prob > Chi <sup>2</sup> = 0.0060					
Pseudo R <sup>2</sup> = 0.3186					

Table 4: Constraints to the

adoption of soil health practices

Constraints	Weighted score	Weight mean ( $\chi$ )	Remark
Land tenure system	114	0.95*	Not severe
Problem of insect pest	209	1.74*	Not severe
Inadequate credit facilities	408	3.40**	Severe
Lack of training	398	3.30**	Severe
Flooding	172	1.43*	Not severe



Drought	249	2.07*	Not severe
Labour	169	1.40*	Not severe
Cost of improve health practices	314	2.61*	Not severe
Unreliable practices	212	1.76*	Not severe
Untimely supply of soil health product	189	1.57*	Not severe
Farm size	178	1.48*	Not severe
Inadequate information on soil health practices	402	3.35**	Severe

**Source: Field survey, 2017**

## REFERENCES

- Arbuckle, J. G. (2012). Attitudes toward cover crops in Iowa: Benefits and barriers. *Iowa Agricultural and Applied Economics* 31 (1): 133-147.
- Bergtold, J. S., Patricia A. D., Diane H., and Randy L. R.. (2012). "Demographic and management factors affecting the adoption and perceived yield benefit of winter cover crops in the southeast." *Journal of Agricultural and Applied Economics* 44 (1): 99 - 116.
- Carlisle, L. (2015). *Lentil underground*. New York: Gotham Books.
- Canales, Elizabeth.(2015) Estimating farmers risk attitudes and risk premiums for the adoption of conservation practices under different contractual arrangement. A stated choice experiment PhD diss, department of agricultural Economics, Kansas state university. unpublished
- Carolan, M. S. (2005). Barriers to the adoption of sustainable agriculture on rented land: An examination of contesting social fields. *Journal of Rural Sociology* 70 (3): 387-413. *Farm and Rural Life Poll*. Ames, IA: Iowa State University Extension and Outreach.
- Featherstone, Allen M., and Barry K. Goodwin.(1993)."Factors influencing a farmer's decision to invest in long-term conservation improvements." *Land Economics* 69 (1): 67-81.
- Fuglie, Keith O. (1999). "Conservation tillage and pesticide use in the Cornbelt." *Journal of Agricultural and Applied Economics* 31 (1): 133-147.
- Mohamed, K. and Temu, A, (2008). Access to credit and its effect on the adoption of agricultural technologies the case of Zarizibar, African review of money finance and banking Pp. 45-89
- Simitowe, F.& Zeller, M. (2006). The impact of Access to credit on the adoption of hybrid maize in malawi; An empirical test of an agricultural household model under credit market failure, MPRA paper no.45
- Simitowe, F. & Zeller, M.(2006). The impact of Access to credit on the adoption of hybrid maize in Malawi; An empirical test of an agricultural household model under credit market failure, MPRA paper no.45
- Snapp, S., S M swinton, R labarta, D. Mutch, J.R Black, R leep, J. Nyiraneza and k. Oneil (2005). Evaluating cover crops for benefits, costs and performance within cropping system niches" *Agronomy journal* 97(1); 322-332
- Stivers-young, Lydia J. and frances, A. T. (1999) cover cropping practices of vegetable; producers in western new York hart technology 9 (3):459-465.
- Muzari, W. Gatsi W & murhunzi, S. (2013). The impacts of technology adoption on small holder Agricultural productivity in sub-saharan Africa; *Journal of sustainable development*; 5(8); 221-229

# EFFECT OF DIFFERENT PROCESSING METHODS ON THE CHEMICAL COMPOSITION OF WATER HYACINTH LEAVES

Ibrahim R.\*, A.B. Gana, T. Iriobe and S. B. Mustapha

Department of Forestry and Fisheries, Kebbi State University of Science and Technology, Aliero.

\*Corresponding Author's E-mail: ibrahim.rasaq@ksusta.edu.ng, GSM: 07039063757

## ABSTRACT

The study was carried out to investigate the effect of different processing methods on the chemical composition of water hyacinth leaves (*Eichhornia crassipes*). The water hyacinth leaves were collected from Sabiyal lake, in Aliero Local Government Area, Kebbi State and subjected in to five different processing methods, designated as T1 (Air-dried: control), T2 (Soaked in freshwater), T3 (Soaked in hot water), T4 (Ferment without yeast) and T5 (Fermented with yeast). Proximate composition of water hyacinth leaves showed that fermented leaf meal had the higher values (T5: 15.83±0.63%) and (T4: 12.84±0.28%) of crude protein. Analysis of anti-nutritional factors revealed that Cyanide, Nitrate, Tannin and Oxalate reduced significantly ( $P<0.05$ ) after the processing of water hyacinth leaves meal. The mineral composition (Calcium, Magnesium, Potassium, Phosphorus, Nitrogen, and Sodium) recorded revealed there was significant different ( $P<0.05$ ) in values of processed water hyacinth leaf meal. In view of the study, it appeared that processed water hyacinth leaf meal has a potential to be utilized as a sources of energy in the animal feeds.

**KEYWORDS:** Processing, methods, proximate, anti-nutritional, minerals

## INTRODUCTION

Fish is very important in the diet of many Nigerians, high in nutritional value with complete array of amino acids, vitamins and minerals (Akinrotimi *et al.*, 2007). Fish consumption provides humans with essential long-chain fatty acids which are beneficial to cardiovascular health (Uauy and Valenzuela 2000; Kris-Etherton *et al.*, 2003). Fish products are relatively cheaper compare to beef, pork and other animal protein sources in the country (Amao *et al.*, 2006). FAO (2007) reported that fish contribute more than 60 % of the world supply of protein, especially in the developing countries. In Nigeria, fish supply is from four major sources viz. artisanal fisheries, industrial trawlers, aquaculture and imported frozen fish (Akinrotimi *et al.*, 2007). Production from aquaculture is increasing compared to artisanal sources and supplied from 5 – 22 % of total domestic fish production between 2000 – 2007 (FDF, 2007). However, this increasing production is not able to meet the rate of consumption because of the wide gap between fish demand and supply, which is on the rise as a result of population explosion in the country in recent years (Falaye and Jenyo-Oni, 2009).

Efficient production of fish in aquaculture depend on feeding the best feeds at levels not exceeding the dietary requirement (Ayinla and Bekibele, 1992). Artificial feeds are materials or mixture of materials other than natural live food offered to fish for the purpose of meeting the nutrient requirement (Ayinla

and Bekibele, 1992). A wide range of feed stuffs are produced as a by-products from animal processing industries (Ahmad and Ibrahim, 2016). Some of this feed stuffs are currently used in rations for both terrestrial and aquatic animals (Udo and Umoren, 2011). Since fish feeds generally represent the largest single cost item of most fish farm operations (Ovie and Eze, 2013). Two sources of fish feeds have been identified namely, plant and animal sources. Water hyacinth (*Eichhornia crassipes*) is an invasive plant that is native of the Amazon basin (Barret and Forno, 1982) and whose capacity for growth and propagation causes major conservation problems with considerable socio-economic repercussions. Most of the problems associated with *E. crassipes* are due to its rapid growth rate, its ability to successfully compete with other aquatic plants, and its ease of propagation (Jianqing *et al.*, 2001). The nutritive value of *E. crassipes* and its usefulness as animal feed cannot be over emphasize (Sashi, 2015). However, *E. crassipes* can be a potential ingredient in farm-mixed feeds for the farming of either herbivorous or omnivorous freshwater fish in simple farming systems where it is available at low cost (Sashi, 2015). There is no or little information on the effect of different processing methods on chemical composition of water hyacinth leaves. The present study is therefore aimed at providing information on the effect of different processing methods on chemical composition of water hyacinth leaves.



## METHODOLOGY

### Collection and Preparation of Water Hyacinth Leaves Samples

The Water hyacinth leaves were collected from Sabiyal Lake, Aliero Local Government Area of Kebbi State. Authentication was carried out in the herbarium of the Department of Forestry and Fisheries, Kebbi State University of Science and Technology, Aliero. The leaves were washed using tap water to remove the dust and different methods of processing were employed to prepare the leaf meals and thereafter the proximate analysis, anti-nutrients and minerals compositions of the samples was determined. The samples were subjected to the following processing techniques, as described by Padmavathy and Shobha (1987) and used by Ibrahim *et al.* (2018).

- i. The water hyacinth leaf weighing 1 kilogram was Air-dried for a week.
- ii. The water hyacinth leaf weighing 1 kilogram was Soaked in freshwater at 1 kilogram leaf per 5 litre of water for 36 hours. The leaf were then collected by losing the water and then air-dried for a week.
- iii. The water hyacinth leaf weighing 1 kilogram was Soaked in 60°C hot water and was allowed to cool down for 24 hours. The leaves were then collected by losing the water and air-dried for a week.
- iv. The water hyacinth leaf weighing 1 kilogram was Fermented in air-tight container for 72 hours. The leaves were then collected and air-dried for a week.
- v. The water hyacinth leaf weighing 1 kilogram was Fermented with yeast (*Saccharomyces cerevisiae*) of 2 kg in air tight container for 72 hours. The leaves were then collected and air-dried for a week.

The leaf samples were taken to Agric Chemical Laboratory, Faculty of Agriculture, Usmanu Danfodiyo University, Sokoto for Analysis. The proximate analysis of leaf meals were determined following methods described by the AOAC (1990). Proximate components such as moisture, crude protein, crude lipid and ash were analyzed. The anti-nutritional compounds were determined (tannin, phytate, nitrate and hydrocyanic acid were determined by using colorimetric approach) as described by AOAC (1990). The oxalate was determined as described by Krishna and Ranjhan (1980). Minerals were extracted from the sample by the wet digestion method (Vadivel and Janardhanan, 2000). The minerals such as calcium, magnesium,

phosphorous, nitrogen, sodium, potassium were carried out according to the method described by AOAC (1990).

### Data Analysis

The data was subjected to analysis of variance (ANOVA) to test the significance among treatment means. Where there was significant difference, Duncan Multiple Range Test (DMRT) was applied to rank treatment means ( $P < 0.05$ ). All statistical analyses were computed using SPSS (IBM) Statistical package Version 22 for Windows.

## RESULTS AND DISCUSSION

### Proximate Composition of Air-dried and Processed Water Hyacinth Leaf Meal:

The proximate composition of air dried and processed water hyacinth leaf meal is shown in Table 1. The moisture content ranges from  $14.50 \pm 0.29\%$  to  $16.67 \pm 0.33$  while the crude protein ranges from  $9.99 \pm 0.26\%$  to  $15.83 \pm 0.63\%$ . The highest crude protein (15.83%) was recorded in T5 and the lowest (9.99%) was recorded in T2. The highest value of ether extract was recorded in T3 ( $6.07 \pm 0.72\%$ ) and the least ( $5.20 \pm 0.15\%$ ) was obtained in T5, The ash content ranges from  $6.17 \pm 0.33\%$  to  $9.83 \pm 1.36\%$ , crude fibre ranges from  $6.34 \pm 0.64$  to  $10.17 \pm 0.17$ , while Nitrogen free extract percentages ranged from  $50.00 \pm 0.63\%$  to  $53.87 \pm 1.68\%$ .

### Anti-nutritional factors of Air-dried and Processed Water Hyacinth Leaf Meal

The anti-nutritional factors in water hyacinth leaf meal. A tannin concentration ranges from  $0.26 \pm 0.06$  to  $0.82 \pm 0.00 \text{mg}/100\text{g}$ . In air dried leaves phytate has the highest value ( $4.03 \pm 0.09 \text{mg}/100\text{g}$ ) and nitrate has the lowest value ( $0.02 \pm 0.00 \text{mg}/100\text{g}$ ). In air dried and processed water hyacinth leaf meal, the values of oxalate ranged from  $0.43 \pm 0.28 \text{mg}/100\text{g}$  to  $1.10 \pm 0.06 \text{mg}/100\text{g}$ , while cyanide ranged from  $0.13 \pm 0.00 \text{mg}/100\text{g}$  to  $0.49 \pm 0.00 \text{mg}/100\text{g}$ . This study revealed that all the components determined were greatly reduced after processing methods of the leaves as shown in Table 2.

### Mineral Compositions of Air-dried and Processed Water Hyacinth Leaf Meal

The minerals composition of water hyacinth leaf meal such as sodium, potassium, calcium, magnesium, phosphorous and nitrogen were determined. Sodium concentration ranges from  $28.67 \pm 1.20$  to  $42.33 \pm 0.67 \text{mg}/\text{kg}$ . In the air dried and processed water hyacinth leaf meal, the values of calcium ranges from  $2.23 \pm 0.09$  to  $5.43 \pm 0.07 \text{mg}/\text{kg}$ , nitrogen ranges from  $0.67 \pm 0.23$  to  $1.60 \pm 0.32 \text{mg}/\text{kg}$



while magnesium ranges from  $3.30\pm 0.06$  to  $4.17\pm 0.72$ mg/kg. There was a significant difference between air dried and processed water hyacinth leaf meal ( $P<0.05$ ) as shown in Table 3.

## DISCUSSION

The proximate composition of air dried water hyacinth leaf obtained from this study differs to that reported by Mako *et al.* (2012) where they examined nutritive evaluation and acceptability of two aquatic weeds (*Eichhornia crassipes* and *Acroceras zizanioides*) by West African dwarf goats. The crude protein, crude fibre and ash content obtained in this study was lower than that reported by Mako *et al.* (2012), while nitrogen free extract and ether extract recorded higher value. The differences observed in the proximate composition of air dried water hyacinth leaf from these two studies are probably as a result of factors, such as geographical location of the plant, soil and climatic conditions of cultured environment. FAO (2004) stated that these factors directly affect the composition of plant physiological and chemical composition. It could be observed that the crude protein of fermented water hyacinth leaf meal differed from that of the soaked in both freshwater and hot water. The observed difference may be attributed to leaching of soluble protein into water. This suggestion agrees with the observation of Ani (2008) which showed that *Mucuna* bean seeds soaked in an aqueous solution of potassium bicarbonate at room temperature for 24 hours led to the solubilization and removal of some nitrogenous substance in the bean. The fermented water hyacinth leaf meal indicates a significant increase in the crude protein composition of the leaf meal. The increased level of crude protein is consistent with the findings of Ibrahim *et al.* (2018) who reported, an increase in protein value when *Mucuna* leaf was fermented with yeast. Fermentation could be attributed to net synthesis of protein by fermenting of the leaf, which might have resulted in the production of some amino acids during protein synthesis. Lipid content were found to be significantly lower in the fermented water hyacinth leaf meal. The decrease in lipid contents might be attributed to the increased activities of the lipolytic enzymes during fermentation which hydrolyses fat components into fatty acid and glycerol (Chinma *et al.*, 2009).

The result of the anti-nutritional compounds of the air dried water hyacinth leaf obtained in this study revealed that tannin value (T1:  $0.82\pm 0.00$ mg/100g) fall on the ranged reported by Mako *et al.* (2012), also tannin has higher value than that reported by Adalakun *et al.* (2016), who reported on nutritional and phytochemical quality of some tropical aquatic

plants. This variation could be as a result of difference in environment, probably being a determining factors of type of anti-nutritional compounds in plant. The anti-nutritional compounds of the processed water hyacinth leaf showed significant reduction. The significant reduction of the anti-nutritional compounds soaked in both freshwater and hot water, may be as result of efficacy of water leaching out anti-nutrients in the leaves. This agree with the report of Ibrahim *et al.* (2018) who observed significant reduction in anti-nutritional compounds when *mucuna* leaves were soaked both in cold and hot water. The anti-nutritional compounds of the fermented water hyacinth leaf showed significant reduction, which is in concordant with the reports of Ibrahim *et al.* (2018) on reduction of phytate and tannin by fermentation, when yeast (*Saccharomyces cerevisiae*) was used to ferment *mucuna* leaves, but contradicts the report of Oladele and Oshodi (2008) who observed an increase in phytate and tannin levels by fermentation; it is however possible that the mode of fermentation and the species of organisms involved play crucial roles in the fermentation processes.

The result of the mineral compositions of the air dried water hyacinth leaf obtained in this study show that calcium has lower value than that reported by Adalakun *et al.* (2016) while the sodium, potassium and magnesium recorded have higher value. The differences from these studies observed, may be attributed to difference in locality of the studies. The fermented water hyacinth leaf meal indicates a significant increase in the minerals composition of the leaf. The increased level of minerals composition may be due to activities of micro-organism during fermentations.

## CONCLUSION

The effect of different processing methods on the chemical composition of water hyacinth leaf meal (*Eichhornia crassipes*) were evaluated and all the processing methods significantly reduced the anti – nutritional factors of the leaf. In view of the study, it appeared that processed water hyacinth leaf meal has a potential to be utilized as a sources of energy in the animal feeds.

Table 1: Proximate Composition of Air-dried and Processed Water Hyacinth Leaf Meal

Parameters (%)	Leaf Meal				
	T <sub>1</sub> ±S.E	T <sub>2</sub> ±S.E	T <sub>3</sub> ±S.E	T <sub>4</sub> ±S.E	T <sub>5</sub> ±S.E
<b>Moisture</b>	14.50±0.29 <sup>c</sup>	16.17±0.44 <sup>ab</sup>	16.67±0.33 <sup>a</sup>	14.67±0.17 <sup>c</sup>	15.67±0.17 <sup>b</sup>
<b>Ash</b>	9.83±1.36 <sup>a</sup>	6.17±0.33 <sup>b</sup>	7.33±0.60 <sup>ab</sup>	9.60±0.84 <sup>a</sup>	9.60±0.67 <sup>a</sup>
<b>Ether extract</b>	5.20±0.15 <sup>a</sup>	5.70±0.42 <sup>a</sup>	6.07±0.72 <sup>a</sup>	3.87±0.41 <sup>b</sup>	3.60±0.21 <sup>b</sup>
<b>Crude protein</b>	10.27±0.50 <sup>c</sup>	9.99±0.26 <sup>c</sup>	10.33±0.28 <sup>c</sup>	12.84±0.28 <sup>b</sup>	15.00±0.63 <sup>a</sup>
<b>Crude fibre</b>	10.17±0.17 <sup>a</sup>	8.33±0.44 <sup>ab</sup>	8.10±0.31 <sup>b</sup>	7.33±1.09 <sup>b</sup>	6.34±0.64 <sup>b</sup>
<b>Nitrogen free extract</b>	50.06±0.82 <sup>a</sup>	53.87±1.68 <sup>a</sup>	51.67±0.67 <sup>a</sup>	51.83±1.88 <sup>a</sup>	50.00±0.63 <sup>a</sup>

Mean with different superscript along row were significantly different (P<0.05)

T1 = Air-dried, T2 = Soaked in freshwater, T3 = Soaked in 60°C hot water, T4 = Fermented in air-tight container, T5 = Fermented with yeast.

Table 2: Anti-nutritional Compounds of Air-dried and Processed Water Hyacinth Leaf Meal

Parameters	Leaf Meal				
	T <sub>1</sub> (mg/100g) ±S.E	T <sub>2</sub> (mg/100g) ±S.E	T <sub>3</sub> (mg/100g) ±S.E	T <sub>4</sub> (mg/100g) ±S.E	T <sub>5</sub> (mg/100g) ±S.E
<b>Tannin</b>	0.82±0.00 <sup>a</sup>	0.70±0.00 <sup>b</sup>	0.51±0.00 <sup>c</sup>	0.52±0.00 <sup>c</sup>	0.26±0.06 <sup>d</sup>
<b>Oxalate</b>	1.10±0.06 <sup>a</sup>	0.77±0.07 <sup>ab</sup>	0.67±0.03 <sup>ab</sup>	0.43±0.28 <sup>b</sup>	0.43±0.03 <sup>b</sup>
<b>Phytate</b>	4.03±0.09 <sup>a</sup>	3.83±0.15 <sup>a</sup>	2.83±0.09 <sup>b</sup>	2.03±0.24 <sup>c</sup>	1.00±0.21 <sup>d</sup>
<b>Nitrate</b>	0.02±0.00 <sup>a</sup>	0.02±0.00 <sup>a</sup>	0.02±0.00 <sup>a</sup>	0.15±0.11 <sup>a</sup>	0.16±0.09 <sup>a</sup>
<b>Cyanide</b>	0.49±0.00 <sup>a</sup>	0.20±0.00 <sup>b</sup>	0.19±0.00 <sup>b</sup>	0.13±0.00 <sup>d</sup>	0.15±0.00 <sup>c</sup>

Mean with different superscript along row were significantly different (P<0.05)

T1 = Air-dried, T2 = Soaked in freshwater, T3 = Soaked in 60°C hot water, T4 = Fermented in air-tight container, T5 = Fermented with yeast.

Table 3: Mineral Composition of Air-dried and Processed Water Hyacinth Leaf Meal

Parameters	Leaf Meal				
	T <sub>1</sub> (mg/kg) ±S.E	T <sub>2</sub> (mg/kg) ±S.E	T <sub>3</sub> (mg/kg) ±S.E	T <sub>4</sub> (mg/kg) ±S.E	T <sub>5</sub> (mg/kg) ±S.E
<b>Sodium (Na)</b>	30.00±1.00 <sup>bc</sup>	28.67±1.20 <sup>c</sup>	32.67±0.88 <sup>b</sup>	40.67±0.88 <sup>a</sup>	42.33±0.67 <sup>a</sup>
<b>Potassium (K)</b>	51.33±1.20 <sup>b</sup>	46.00±0.58 <sup>c</sup>	48.67±0.88 <sup>bc</sup>	46.67±0.67 <sup>c</sup>	61.00±1.16 <sup>a</sup>
<b>Calcium (Ca)</b>	2.23±0.09 <sup>b</sup>	2.33±0.03 <sup>b</sup>	2.30±0.31 <sup>b</sup>	5.17±0.58 <sup>a</sup>	5.43±0.07 <sup>a</sup>
<b>Magnesium(Mg)</b>	3.53±0.03 <sup>a</sup>	3.60±0.06 <sup>a</sup>	3.30±0.06 <sup>a</sup>	4.17±0.72 <sup>a</sup>	4.10±0.06 <sup>a</sup>
<b>Phosphorous (P)</b>	0.33±0.00 <sup>b</sup>	0.34±0.00 <sup>b</sup>	0.32±0.00 <sup>b</sup>	1.02±0.13 <sup>a</sup>	1.25±0.35 <sup>a</sup>
<b>Nitrogen (N)</b>	0.67±0.23 <sup>b</sup>	0.68±0.32 <sup>b</sup>	0.91±0.01 <sup>ab</sup>	1.19±0.16 <sup>a</sup>	1.60±0.32 <sup>a</sup>

Mean with different superscript along row were significantly different (P<0.05)

T1 = Air-dried, T2 = Soaked in freshwater, T3 = Soaked in 60°C hot water, T4 = Fermented in air-tight container,

T5 = Fermented with yeast.





## REFERENCES

- Adelakun, K.M., Kehinde A.S., Amali, R.P., Ogundiwin, D.I. and Omotayo, O.L. (2016). Nutritional and Phytochemical Quality of Some Tropical Aquatic Plants. *Poultry, Fisheries and Wildlife Sciences*, 4:2
- Ahmad M.K. and Ibrahim S. (2016). Local fish meal formulation: Its principles, prospects and problems in fishery industry. *International Journal of Fisheries and Aquatic Studies*, 4 (1): 276 – 279
- Akinrotimi, O.A., Onunkwo, D.N. Cliffe, P.T. Anyanwu, P.E. and Orokotan, O.O. (2007). The Role of fish in nutrition and livelihoods of families in Niger Delta, Nigeria. *International Journal of Tropical Agriculture and food systems*, 1(4): 344 – 351.
- Amao, J.O., Oluwatayo I.B. and Osuntope F.K. (2006). Economics of Fish Demands in Lagos State, Nigeria. *Journal of Human Ecology*, 19(1): 25-30.
- Ani, A.O. (2008). The Feeding Value of Processed Velvet Bean (*Mucuna pruriens*) for Pullet Chicks. *Journal of Tropical Agriculture, Food, Environment and Extension*, Volume (7) pp. 149 -155.
- AOAC (Association of Official Analytical Chemist) (1990). *Official Methods of Analyses*, Washington, D.C.
- Ayinla, O.A. and Bekibele, D.O. (1992). Fish feed and nutrition in Nigeria: The present State of knowledge and the ways forward. *African regional aquaculture centre. Technical paper 83*: ISBN 978 – 2345.087
- Barrett B., and Forno I.W. (1982). Style morph distribution in New World populations of *Eichhornia crassipes* (Mart) Solms- Laubach (water hyacinth). *Aquatic Botany*, 13: 299 – 306, [http:// dx.doi.org/10.1016/0304 - 3770\(82\)90065-1](http://dx.doi.org/10.1016/0304-3770(82)90065-1).
- Chinma, C. E., O. Adewuyi and O. J. Abu (2009). Effect of Germination on the Chemical, Functional and Pasting properties of Flours from brown and yellow varieties of Tiger nut (*Cyperus esculentus*). *Food Research International*, 42: 1104-109.
- Falaye, A.E. and Jenyo – Oni, A. (2009). Aquatic biodiversity and the implication in artisanal fishing production. *African Journal of Livestock Extension*. 7: 39 – 43.
- FAO (2004). The State of World Fisheries and Aquaculture Production (SOFIA). *Yearbook Fisheries Statistics*. Rome, Italy: Food and Agriculture Organization of the United Nations.
- Food and Agriculture Organization (2007). *FAO of the United Nations. The state of World Fisheries and Aquaculture 2006*. FAO Fisheries Department, Rome Italy, 30pp.
- Federal Department of Fisheries (2007). *Fisheries Statistics of Nigeria*, FDF fourth Edition 1995 – 2007 49pp.
- Ibrahim, R., Bolorunduro, P. I., Adakole, J. A., Gana A. B. and Iriobe, T. (2018). Effects of Different Processing Methods on the Chemical Composition of *Mucuna pruriens* Leaves. *Greener Journal of Ecology and Ecosolution*, 5(1): 001-005.
- Jianqing D, Ren W, Weidong F, and Guloiang Z. (2001). *Water Hyacinth in China: Its distribution, Problems and Control Status*. In: Julien MH, Hill MP, Centre TD, (ed). *Biological and Integrated Control of Water Hyacinth (Eichhornia crassipes)*. Canberra, Australia.
- Kris-Etherton P.M., Harris W.S. and Appel L.J. (2003). Fish consumption, fish oil, omega-3 fatty acids, and cardiovascular disease. *Arteriosclerosis Thrombosis Vascular Biology*, 23: 20 – 31.
- Krishna, G. and Rarjhan, S.K. (1980). *Laboratory Manual for Nutrition Research*. Vikas publishing House. PVK Ltd, Ghaziabad, UP (India) 121-123.
- Mako, A. A., Banjo, O. S. and Akinwande, V. O. (2012). Nutritive evaluation and acceptability of two aquatic weeds (*Eichhornia crassipes* and *Acroceras zizanioides*) by West African dwarf goats. *African Journal of Agricultural Research*, Vol. 7(19), pp. 3007-3013,
- Oladele, E. P. and Oshodi, A. A. (2008). Effect of Fermentation on some Chemical and Nutritive properties of Berlandier nettle spurge (*Jatropha cathartica*) and physic nut (*Jatropha curcas*) seeds. *Pakistan Journal of Nutrition*, 7: 292-296.
- Ovie S.O. and Eze S.S. (2013). Utilization of Dry Yeast in the Replacement of Fish Meal in *Clarias gariepinus* Diet. *Biological and Environmental Science Journal for the Tropics*, 10 (2):15 – 20.
- Padmavathy, P. and Shobha, S. (1987). Effect of Processing on Protein Quality and Mimosine content of subabul (*Leucaena leucocephala*). *Journal of Food Science Technology*, 24:180-182.
- Sashi B. M. (2015). Utilization of water hyacinth (*Eichhornia crassipes*) meal as partial fish protein replacement in the diet of *Cyprinus carpio* fry. *European Journal of Experimental Biology*, 5 (5): 31 – 36.

Uauy R. and Valenzuela A. (2000). Marine oils: The health benefits of n-3 fatty acids. *Nutrition* 16: 680 – 684.

Udo I.U and Umoren U.E. (2011). Nutritional Evaluation of Some Locally Available Ingredients Use for Least-Cost Ration Formulation for African Catfish (*Clarias gariepinus*) in Nigeria. *Asian Journal of Agriculture Research*; 5:164 – 175.

Vadivel, V., and Janardhanan, K. (2000). Chemical Composition of the underutilized Legume *Cassia hirsuta* L. *Plant Foods for Human Nutrition*, 55: 369- 381.



## GROWTH AND HAEMATOLOGICAL RESPONSES OF *Clarias gariepinus* (BURCHELL, 1822) FINGERLINGS FED PROCESSED BAOBAB SEED MEAL BASED DIETS

Alatise \*, S. P., F. O. A. George \*\*, O. Ogundele \*

\*Fisheries Technology Department, Federal College of Freshwater Fisheries Technology, P.M.B. 1500, New Bussa, Niger State.

\*\*Aquaculture and Fisheries Management Department, Federal University of Agriculture, P.M.B. 2240, Abeokuta, Ogun State.

\*Corresponding Author's E-mail: [segunpeter13@gmail.com](mailto:segunpeter13@gmail.com), GSM: [08057068202](tel:08057068202)

### ABSTRACT

*This present study is aimed at assessing the growth and haematological parameters of African mud catfish, Clarias gariepinus fingerlings fed various processing method of baobab seed meal based diets. Eleven isoproteic 40% crude protein diets were formulated where various processing method of baobab seed meal replaced Soyabean meal (SBM) at 0%, 50% and 100% inclusions. Catfish fingerlings (54.24±7.77g) stocked at 20 fish/net-hapas were fed diets in triplicates three times daily for 56 days in outdoor concrete tank in which data on fish growth and haematology were collected. Data from the completely randomized experiment were subjected to ANOVA analysis and L.S.D. was separated at 5% probability level. Mean weight gain (MWG) and Specific growth rate (SGR) of fish fed 50% boiled baobab seed meal were statistically different ( $p < 0.05$ ) from those fish fed other processed BSM based diets. Fish MWG, SGR, PER and FCR significantly ( $p < 0.05$ ). The packed cell volume (PCV) of the fingerlings ranged between 21.40 - 33.67% with a mean of 27.49%, haemoglobin concentration (Hb) ranged between 7.02 - 11.32% with a mean of 12.68, the mean of the red blood cell (RBC) value was  $1.50 \times 10^{12}/\text{ml}$  and ranged between  $1.33 \times 10^{12}/\text{ml}$  -  $1.67 \times 10^{12}/\text{ml}$ , but the white blood cell (WBC) value ranged between  $2.53 \times 10^9/\text{ml}$  -  $3.84 \times 10^9/\text{ml}$  with a mean of  $3.19 \times 10^9/\text{ml}$ . There were significant difference ( $p < 0.05$ ) in the values of haematological parameters of the African mud catfish, Clarias gariepinus fingerlings fed varying inclusion levels of processed baobab seed meal based diets. The physiological variables in the experiment were within the levels recommended for the culture of freshwater fish.*

**KEYWORDS:** Haematology, *Clarias gariepinus* fingerlings, processed baobab seed meal

### INTRODUCTION

Fish haematological can be referred to as gaining larger importance in fish culture because of its advantage in improving the health status of fish. Haematological features of most fish have been studied with the aim of form normal quality range and deviation from it may show a disturbance in the physiological procedure. Most times environmental and physiological factors are known to affect haematology; these include stress during capturing, sampling, age, transportation and sex. However, in most cases, the knowledge of haematological features of the fish is useful in toxicological studies (i.e. dealing with the nature, effect, detection and treatment of poisons and poisoning) and its effect on the final consumers which is mainly man.

The count of red blood cells is quite a stable index and the fish body tries to maintain this count within the limits of certain physiological standards using various physiological mechanisms of compensation. Studies have shown that when the water quality is affected by toxicants, any physiological changes will be reflected in the values

of one or more of the haematological parameters (Van Vuren, 1986). Blood cell responses are important indicators of changes in the internal and/or external environment of animals. In fish, exposure to chemical pollutants can induce either increases or decreases in haematological levels. Their changes depend on fish species, age, the cycle of the sexual maturity of spawners various processing and diseases (Golovina, 1996; Luskova, 1997).

Like in warm-blooded animals, changes in the blood parameters of fish, which occur because of injuries of the latter organs or tissues, can be used to determine and confirm the dysfunction or injuries of the latter (organs or tissue). However in the fish, these parameters are more related to the response of the whole organism, i.e. to the effect on fish survival, reproduction and growth. It should be noted that although the mechanisms of fish physiology and biochemical reaction to xenobiotics has not been investigated enough, it is obvious that species differences of these mechanisms exist.

African catfish (*Clarias gariepinus*) is one of the most important fish species currently being



cultured both inside and outside its natural range of tropical and subtropical environments (Adewolu *et al.*, 2008; Chepkirui-Boit *et al.*, 2011). Positive attributes such as resistance to diseases, high fecundity, and ease of larval production in captivity makes it of commercial importance in aquaculture (Haylor, 1999; Hogendoorn, 1980 and Kestemont *et al.*, 2007). However, the main constraint facing the culture of *C. gariepinus* is the low survival during the larval and fingerling stages (de Graaf and Janssen, 1996) leading to insufficient amounts of quality catfish seed. High mortality rates occur among larval stages of catfish, some of which are attributed to infectious diseases caused by parasites (Bricknell and Dalmo, 2005). Parasitic pathogens infecting cultured fish are well known to cause mortality and significant losses both in culture and capture fisheries (Costello, 2009; Woo, 2006). It is therefore apparent that management protocols that limit mortality and enhance fingerling growth should be clearly described to ensure improved survival and sufficient supply of catfish fingerlings.

Baobab, *Adansonia digitata* is the most widespread of the *Adansonia* species, and is native to the African continent. The long-lived pachycauls are typically found in dry, hot savannahs of sub-Saharan Africa, where they dominate the landscape, and reveal the presence of a watercourse from afar (Wickens and Gerald, 2008). Their growth rate is determined by ground water or rainfall (Hankey and Andrew, 2004; Grove and Naas, 2011), and their maximum age, which is subject to much conjecture, seems to be in the order of 1,500 years (Woodborne and Stephen, 2015). They have traditionally been valued as sources of food, water, health remedies or places of shelter and are steeped in legend and superstition (Hankey and Andrew, 2004). European explorers of old were inclined to carve their names on baobabs, and many are defaced by modern graffiti (Wickens and Gerald, 2008).

The objective of this study was to assess the haematological parameters of *Clarias gariepinus* fingerlings fed various processing method of baobab seed meal based diets.

## **MATERIALS AND METHODS**

### **Experimental site**

The experiment was carried out at the outdoor research concrete tanks (2) of the hatchery unit (8m x 5m x 1.5m) of the Federal College of Freshwater Fisheries Technology (FCFFT), New Bussa, Niger State, Nigeria. The concrete tanks used for the experiment was prepared by washing thoroughly with water and left to dry. The net-hapas (33) were set before the concrete tanks were filled to about two-third of the height of the tanks.

### **Experimental Procedure**

All feed ingredients used in the experiment except Baobab seed meal was purchased from Ojasope feed shop, Ibadan way, New Bussa, Baobab, *Adansonia digitata* seed was purchased at Dogongari market, a suburb of New Bussa. The seeds were washed with clean water to remove all dirt and soil particles, they were dehulled and winnowed and suited to five different processing methods as follows, Soaking at 24hours to 96 hours boiling at 15 minutes to 60 minutes, toasting at 15minutes to 60 minutes, fermenting at 3days to 9 days and autoclaving at 15 minutes to 60 minutes.

After the processing, the seeds were subsequently milled to obtain a homogenous powder and stored in an air tight plastic container before analysis was carried out. The proximate analysis was determined and the results obtained served as a basis for determining the baobab seed meal that were used for the feeding trials.

Eleven isoproteic (40% crude protein) diets were prepared in which the processed baobab seed meal replaced soyabean meal at the following inclusion levels (0%, SBSM (50%); SBSM (100%); BBSM (50%); BBSM (100%); TBSM (50%); TBSM (100%); FBSM (50%); FBSM (100%); ABSM (50%) and ABSM (100%) respectively (Table 1). The control diet does not contain any of the processed methods, only soyabean meal was used at 0%. The processed baobab seed meals were varied and replicated at 50% and 100% inclusion levels because they are plant protein sources.

The ingredients were milled with hammer mill and properly mixed with hand and the diets were pelletized through 2mm diameter die, using the Flat die pelletizer of 40-60kg/hour capacity. The diets were sun dried and stored in tagged polythene bags and stored in dry place at room temperature.

### **Feeding and Sampling methods**

The pelleted feed was initially ground and fed to the triplicate groups of the experimental fish for fifty-six (56) days at a feeding rate of 5% of their body weight per day. The experimental fish were fed twice per day at 7:00am and 5:00pm daily. Sampling was carried out weekly (every Friday) to determine the increase in their body weight. The new feeding rate for each treatment was adjusted depending on their new body weight. The fish were weighed using an electronic sensitive weighing balance (OHAUS-LS-400g) model. The fish were also weighed in an enclosed house because of the high sensitivity of the weighing balance to wind which could affect the accuracy of the readings displayed by the weighing balance.

### Growth Parameters

The growth parameters according to the method described by Olvera – Nova *et. al.*, (1990) as follows:

#### Mean weight gain (%MWG)

This is the difference between the initial and the final weight gained, divided by the number of the surviving fish at the end of the culture period.

$$(\%MWG) = \frac{\text{Final body weight} - \text{Initial body weight}}{\text{Number of surviving fish}} \times 100$$

#### Feed Conversion Ratio (FCR)

This was determined by dividing the total weight of the feed given by the total increase in weight gained by the fish over a given period of time.

$$FCR = \frac{\text{Weight of feed given}}{\text{Increase in weight of fish}}$$

#### Feed Intake (FI)

This was calculated by the addition of daily mean feed intake of fish in each treatment for the experimental period.

#### Average Growth Rate (AGR)

This was calculated by the differences between the final weight and the initial weight, divided by the number of days i.e. the experimental period.

$$AGR = \frac{\text{Final weight} - \text{Initial weight}}{\text{Number of days}}$$

#### Specific Growth Rate (SGR)

This is the relationship of difference in weight of the fish within the experimental period.

$$SGR = \frac{(\ln W_f - \ln W_i) \times 100}{\text{Time}}$$

#### Protein Efficiency Ratio

$$PER = \frac{\text{Fish weight gain}}{\text{Protein gain}}$$

### Haematological Examination

The following parameters were used to assess the effects of dietary treatments on the haematological profile of *Clarias gariepinus* at the beginning and end of the feeding trials. Blood samples for haematological analysis collected from the caudal peduncle with a fine syringe (1ml) into a heparinized bottle. Blood was drawn into haematocrit tube from this sample.

#### Haematocrit (Packed Cell Volume)

Heparinized capillary tubes were 75% filled with blood sample by suction pressure and the end sealed with plasticine. The tubes were centrifuged for 5 minutes in haematocrit centrifuge at 3000 r.p.m.,

the packed cell volume (PVC) was read by the use of Rami haematocrit reader UV-VIS spectrophotometer 108. The results were expressed in percentages.

#### Plasma Volume

This was determined according to the method of Lamb (1981). After determining the haematocrit, the sample was used for plasma sample determination (per 100ml of blood), which is the difference between the total volume of the blood centrifuge and the packed cells volume.

#### Haemoglobin Concentration (Hb)

The cyanmethaemoglobin method of both Schaum *et. al.*, (1975) and Kelly (1979) were used for this analysis. 0.02ml of well mixed blood was added to 4ml of modified Drabkins solution (a mixture of 250g Potassium ferricyanide, 200mg Potassium cyanide and 50mg Potassium dihydrogen phosphate) and the volume diluted to 1litre with distilled water. The mixture was allowed to stand for 35 minutes and the haemoglobin concentration (g/dl) was read photometrically by comparing with the cyanmethaemoglobin standard with yellow-green filler at 625nm.

#### Red Blood Cell (RBC) and White Blood Cell (WBC)

The blood cells counts were carried out by the use of Newbarr haemocytometer as described by Kelly (1979). For the Red Blood Cell (RBC), it was determined by diluting 1:200 of the blood sample with Dacie's fluid (a mixture of 99ml of 3% aqueous solution of sodium citrate and 1ml of 40% formaldehyde) which keeps and preserves the shape of red blood cells. For White Blood Cell (WBC), the dilution was 1:20 using 3% aqueous solution of acetic acid to which gentian violet was added. 1ml of the sample was dropped on a microscope slide and labeled according to the various dietary treatments. Counting was done using light microscope. Red blood cell and White blood cell counts were obtained from  $\times 10^6/\text{dl}$  and  $\times 10^3$  respectively.

#### Mean Cells Volume (MCV)

The mean volume of red blood cells is termed the mean cells volume ( $\mu\text{m}^3$ ) Swensen, 1951 and Schalm *et. al.*, (1975). This was determined according to the method used by (Oyelese *et. al.*, 1999 and Sogbesan, 2007).

$$MCV (\mu\text{m}^3) = \frac{\text{Haematocrit} \times 10}{\text{Number of red blood cells per 100ml blood}}$$

#### Mean Cells Haemoglobin (MCH)



The mean cell haemoglobin was calculated by the following method used by Hemre et. al., 1995 as  
$$\text{MCH } (\mu\text{g}l^{-1}) = \frac{\text{Haemoglobin} \times 10}{\text{Number of red cells per 100ml blood}}$$

### Mean Corpuscular Haemoglobin Concentration (MCHC)

This was derived from the relationship between the haemoglobin concentration and the haematocrit according:

$$\text{MCHC} = \frac{\text{Haemoglobin content} \times 100}{\text{Haematocrit} \quad \text{dl}}$$

## RESULTS AND DISCUSSION

### Proximate Composition of the experimental diets

The proximate compositions of the experimental diets are shown that the moisture content values of the experimental diets ranged between 8.49% in diet 7 with 100% toasted baobab seed meal replacement to 10.06% in diet 4 with 50% boiled baobab seed meal replacement. The crude protein values ranged between 38.21% in diet 6 with 50% toasted baobab seed meal replacement to 40.16% in diet 2 with 50% soaked baobab seed meal replacement.

The lipid values ranged between 3.73% in diet 7 with 100% toasted baobab seed meal replacement to 4.53% in diet 4 with 50% boiled baobab seed meal replacement. The nitrogen free extract (NFE) values also ranged between 32.47% in diet 4 with 50% boiled baobab seed meal replacement to 36.39% in diet 5 with 100% boiled baobab seed meal replacement. The calculated metabolizable energy ranged between 289.01kcal/g in diet 7 with 100% toasted baobab seed meal replacement to 296.63kcal/g in diet 9 with 100% fermented baobab seed meal replacement. The crude fibre ranged between 4.24% in diet 2 with 50% soaked baobab seed meal replacement to 6.62% in diet 1 (control).

The energy/protein ratio values ranged between 7.28% in diet 11 with 100% autoclaved baobab seed meal replacement to 7.67% in diet 5 with 100% boiled baobab seed meal replacement. It was observed that ash value was highest in diet 7 with 100% toasted baobab seed meal replacement and lowest in diet 5 with 100% boiled baobab seed meal replacement.

### Growth performance and nutrient utilization of *Clarias gariepinus* fingerlings fed processed baobab seed meal based diets for 56 days

The growth performance and nutrient utilization of *Clarias gariepinus* fingerlings fed processed baobab seed meal based diets for 56 days is presented in Table 2. The mean weight gain of 458.50g was highest in diet 4 with 50% boiled

baobab seed meal replacement, followed by 318.17g in diet 10 with 50% autoclaved baobab seed meal replacement and closely followed by 215.99g in diet 1 (control). The mean weight gain of 10.68g was lowest in diet 3 with 100% soaked baobab seed meal replacement, followed by 42.71g in diet 7 with 100% toasted baobab seed meal replacement.

The mean specific growth rate of 3.91%/day was highest in diet 4 with 50% boiled baobab seed meal replacement, followed by 3.20%/day in diet 10 with 50% autoclaved baobab seed meal replacement and closely followed by 2.79%/day in diet 1 (control). The mean specific growth of 0.30%/day was lowest in diet 3 with 100% soaked baobab seed meal replacement, followed by 0.84%/day in diet 7 with 100% toasted baobab seed meal replacement.

The mean feed intake value of 479.64g was highest in diet 4 with 50% boiled baobab seed meal replacement, followed by 381.99g in diet 10 with 50% autoclaved baobab seed meal replacement and closely followed by 346.66g in diet 1 (control). The lowest feed intake value of 177.73g was recorded in diet 7 with 100% toasted baobab seed meal replacement, closely followed by 181.65g in diet 3 with 100% soaked baobab seed meal replacement and 194.02g in diet 6 with 50% toasted baobab seed meal replacement.

The best feed conversion ratio of 1.07 was recorded in diet 4 with 50% boiled baobab seed meal replacement, followed by 1.34 in diet 10 with 50% autoclaved baobab seed meal replacement and 1.64 in diet 1 (control). The worst feed conversion ratio of 364.54 was recorded in diet 3 with 100% soaked baobab seed meal replacement, followed by 11.37 in diet 7 with 100% toasted baobab seed meal replacement and 8.36 in diet 6 with 50% toasted baobab seed meal replacement. It should be noted that the lower the value of feed conversion ratio, the better for the fish as less diets will be converted into flesh.

The mean protein efficiency ratio of 2.35% was highest in diet 4 with 50% boiled baobab seed meal replacement, followed by 1.95% in diet 10 with 50% autoclaved baobab seed meal replacement and 1.58% in diet 1 (control). The lowest protein efficiency ratio of 0.14% was recorded in diet 3 with 100% soaked baobab seed meal replacement. There was no significant difference ( $p < 0.05$ ) between the protein efficiency ratio of diet 5 (0.90%), diet 11 (0.94%) and diet 2 (0.96%), but significant difference in diet 7 (0.49%), diet 6 (0.64%) and diet 9 (1.18%) respectively.

The mean total fish production of 36.24kg/m<sup>3</sup> was highest in diet 4 with 50% boiled baobab seed meal replacement, followed by 25.55kg/m<sup>3</sup> in diet 10 with 50% autoclaved baobab



seed meal replacement and 15.96kg/m<sup>3</sup> in diet 1 (control). The lowest mean total fish production of 2.44kg/m<sup>3</sup> was recorded in diet 3 with 100% soaked baobab seed meal replacement which was followed by 4.15kg/m<sup>3</sup> in diet 6 with 50% toasted baobab seed meal replacement and 5.43kg/m<sup>3</sup> in diet 7 with 100% toasted baobab seed meal replacement. Generally, it was observed that feed ingredients with 50% replacement levels produced better results throughout the culture period.

#### **Haematological profile of *Clarias gariepinus* fed processed baobab seed meal based diets**

Haematological investigations have proven valuable for fisheries biologists for quick detection of changes in fish health and these changes may precede changes in fish behavior and visible lesion (Elahee and Bhagwant, 2007). Ekanem (2011) reported that abnormalities in fish due to difference in the diets can be detected by comparing the blood parameters of the affected fish with that of the control or with normal blood profile if such is available.

There were significant increases in haematocrit, haemoglobin, red blood cell count, white blood cell platelet, erythrocyte sedimentation rate and lymphocytes of the fish fed processed baobab seed meal based diet. The boiled baobab seed meal based diets fed to the fish displayed the ability to trigger erythropoiesis and their results was in agreement with those obtained in rats and this mechanism seems to prevent the average life span of individual Red blood counts (Oluyemi *et. al.*, 2007).

The increase in haematological parameters of both the control and the tested diets of DT2 and DT8 agreed with the findings of (Joshi *et. al.*, 2002) that survival of fish can be correlated with moderate inclusion level of non-conventional feed resources which help the survival of the fish. The significant difference ( $p < 0.05$ ) between the fish fed the control and the processed baobab meal based diets in all the blood parameters especially red blood cell, haemoglobin, PCV, white blood cell count showed that the fish tolerated the various percentage inclusion levels of the baobab seed meal, since the values obtained after the feeding were within the ranges of healthy *Clarias gariepinus* by (Erondu *et. al.*, 1993).

Haematocrit 22-31%, haemoglobin 7.40-9.17g/100ml, 0.66-1.96 x 10<sup>6</sup>mm<sup>3</sup>; (14.15- 17.73 x 10<sup>3</sup>) compared to (Erondu *et. al.*, 1993) which had 20-38% haematocrit; 7.00-18.00g/100ml; haemoglobin; 0.66-1.96x10<sup>6</sup> erythrocytes and leucocytes 1.00-4.30 x 10<sup>3</sup>mm<sup>3</sup>). The proliferation of WBC in the entire culture group could lead to leucopoiesis, particularly lymphopoiesis as a response to enhanced immunity. Furthermore, increase in total WBC as observed in the fish fed the tested diets is

attributed to increase in production of leucocytes in the haematopoietic tissue of the kidney and perhaps the spleen. Lymphocytes are the most numerous cells comprising the leucocytes, which function in the production of chemical substance serving as defense against infection. Blood composition is usually altered during decrease or malnutrition conditions (Feist and Longsham, 2000). Alektor and Egberongbe (1986) reported that red blood cell count and packed cell volume (PCV) are mostly affected by dietary treatments. Under normal conditions, the composition of blood is reasonably constant for any particular species with changes falling with fairly narrow limit (Banerjee *et. al.*, 2002). Difference in blood parameters in this study could therefore be attributed to the effect of the processed baobab seed meal based diets.

#### **CONCLUSION AND RECOMMENDATIONS**

This study showed that the replacement of soyabean meal with baobab seed meal at various inclusion levels of 50% and 100% could be used in fish feeding without negatively affecting the productivity. The utilization of baobab seed meal by fish when processed by boiling was better at 50% inclusion level than other processing methods. Since weight gain of fish is what would translate into income for the fish farmer at the end of the production cycle, 50% inclusion level of boiled baobab seed meal (BBSM) in catfish diet would produce better and profitable result at present.

The use of 50% Boiled Baobab seed meal inclusion level in the diet of African mud catfish, *C. gariepinus* fingerlings is recommended. However, there is still need for further studies towards increasing the utilization level of boiled baobab seed meal (BBSM) to 75% inclusion level as most utilization and haematological parameters assessed in this study were marginally different from those of 50% inclusion level.

#### **ACKNOWLEDGEMENTS**

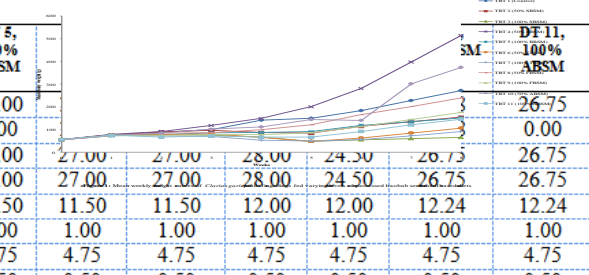
My special gratitude goes to God Almighty for the wisdom, knowledge and understanding bestowed on me throughout the course of this research work. My profound gratitude goes to my Provost and entire staff of the Federal College of Freshwater Fisheries Technology, New Bussa, Niger State for making all things possible for me to achieve this goal. I am highly indebted to my supervisors in persons of; Professor S. O. Otubusin, Professor F. O. A. George and Professor A. M. Bamigbose, for taking time despite their tight schedule to read through, criticized, correct and ensure that this work was successful. My sincere appreciation goes to ICAAT for organizing the conference and to Dr. B.

D. Olaosebikan, Dr. J. O. Fakunle and Mohammed Shaba for their untiring efforts, without which the success of the work wouldn't have been possible. I finally wish to thank all the members of my family for their patience, endurance and support.



Table 1: Percentage Composition of the experimental diets per 100g

FEEDSTUFF	DT 1, 0% BSM	DT 2, 50% SBSM	DT 3, 100% SBSM	DT 4, 50% BBSM	DT 5, 100% BBSM	DT 6, 50% SBSM	DT 7, 100% SBSM	DT 8, 50% BBSM	DT 9, 100% BBSM	DT 10, 50% SBSM	DT 11, 100% BBSM
Baobab seed meal (processed)	0.00	13.00	26.00	12.50	25.00	0.00	0.00	0.00	0.00	0.00	26.75
Soyabean meal (44%)	26.00	13.00	0.00	12.50	0.00	27.00	27.00	28.00	24.50	26.75	0.00
Groundnut cake meal (40%)	26.00	26.00	26.00	25.00	25.00	27.00	27.00	28.00	24.50	26.75	26.75
Fish meal (72%)	26.00	26.00	26.00	25.00	25.00	27.00	27.00	28.00	24.50	26.75	26.75
Yellow maize (10%)	14.50	14.50	14.50	17.50	17.50	11.50	11.50	12.00	12.00	12.24	12.24
Vitamin premix	1.00	1.00	1.00	1.00	1.00	1.00	1.00	1.00	1.00	1.00	1.00
Vegetable oil	4.75	4.75	4.75	4.75	4.75	4.75	4.75	4.75	4.75	4.75	4.75
Methionine	0.50	0.50	0.50	0.50	0.50	0.50	0.50	0.50	0.50	0.50	0.50
Lysine	0.50	0.50	0.50	0.50	0.50	0.50	0.50	0.50	0.50	0.50	0.50
Di-calcium phosphate	0.50	0.50	0.50	0.50	0.50	0.50	0.50	0.50	0.50	0.50	0.50
Salt (NaCl)	0.25	0.25	0.25	0.25	0.25	0.25	0.25	0.25	0.25	0.25	0.25
<b>TOTAL</b>	<b>100</b>	<b>100</b>	<b>100</b>	<b>100</b>	<b>100</b>	<b>100</b>	<b>100</b>	<b>100</b>	<b>100</b>	<b>100</b>	<b>100</b>



Hi-Nutrients Vitamins/ Minerals premix supplies 100g Diet. Palmat A: 1000IU; Cholecalceferol (D): 1000IU; G-Tocopherolacetate (E): 1.1mg; Menacilione (K): 0.02mg; Thiamine B1: 0.63mg; Riboflavin (B12): 0.001mg; Nicotinic Acid: 3.0mg; Folic Acid: 0.1mg; Choline: 31.3mg; Ascobic Acid: 0.1mg; Iron (Fe): 0.05mg; Cu: 0.25mg; Mn: 6.00mg; Co: 0.5mg; Zn: 5.0mg; Sn: 0.02mg

Table 2: Growth performance and nutrient utilization of *Clarias gariepinus* fingerlings fed processed baobab seed meal based diets for 56 days

Experimental diets	IMW (g)	FMW (g)	MWG (g)	RWG (%)	DGR (g/day)	SGR (%/day)	FCR	PER (%)	TIFF (kg/m <sup>3</sup> )			
Diet 1 (Control)	55.69±0.30*	271.68±74.68**	215.99±74.44**	387.45±132.10**	5.86±1.33**	2.79±0.48**	346.66±80.44**	1.64±0.14*	154.92±33.20**	1.84±0.14**	56.67±14.43*	15.94±7.39**
Diet 2 (50% SBSM)	55.80±0.06*	154.33±30.84*	99.23±20.78*	176.41±35.21**	1.77±0.25*	1.80±0.37**	21.06±4.10**	2.76±0.27*	103.55±21.21**	0.94±0.28**	36.67±7.84*	5.32±2.29**
Diet 3 (100% SBSM)	55.63±0.33*	68.31±9.37*	10.85±10.20*	19.26±18.48*	0.19±0.19*	0.19±0.19*	181.33±74.11*	0.94±0.10**	14.75±2.64*	0.14±0.13*	36.97±11.23*	2.44±0.55*
Diet 4 (50% BBSM)	55.32±0.38*	214.02±41.21.04*	438.50±41.71.63*	824.44±302.43*	8.19±3.06*	3.91±0.55*	478.64±116.20*	1.07±0.11*	191.37±30.57**	2.15±0.24*	66.97±20.21*	36.24±21.91*
Diet 5 (100% BBSM)	55.52±0.24*	158.16±48.14*	102.65±48.98*	184.56±47.07*	3.24±2.72*	1.66±1.13**	233.77±87.11*	5.49±2.39*	97.37±17.88**	0.90±0.86*	41.04±21.79*	8.29±4.29**
Diet 6 (50% TBSM)	55.75±0.15*	108.74±40.14*	20.99±40.28*	91.63±40.48*	0.91±1.05*	0.99±0.93**	194.02±21.88*	0.82±0.38*	14.73±2.87**	0.64±0.71*	33.33±12.23*	4.15±4.06*
Diet 7 (100% TBSM)	55.89±0.15*	98.40±45.39*	42.71±28.27*	76.33±100.72*	0.76±1.00*	0.84±0.94*	67.73±38.11*	11.37±9.32*	69.28±26.33*	0.49±0.71*	42.00±17.84*	5.43±3.98**
Diet 8 (50% FBSM)	55.22±0.05*	239.73±41.22**	184.51±41.22.48**	354.27±203.90**	3.30±2.00*	2.47±0.92**	311.15±63.26**	2.16±1.26*	122.03±54.81**	1.45±0.83**	31.67±10.41*	12.93±7.25**
Diet 9 (100% FBSM)	55.66±0.35*	175.76±63.97*	120.70±64.13*	215.98±118.02*	2.14±1.13*	1.95±1.73**	245.40±6.78*	2.53±1.33*	97.37±14.87**	0.18±0.51*	31.67±14.43*	9.67±5.31**
Diet 10 (50% ABSM)	55.70±0.17*	373.87±224.47**	318.17±224.43**	371.05±402.09**	5.88±4.00*	3.20±1.00*	331.99±181.03**	1.30±0.51*	151.73±68.54*	1.30±0.33*	61.97±21.78*	25.53±21.84**
Diet 11 (100% ABSM)	55.80±0.10*	146.11±75.39*	90.51±75.32*	162.87±135.40*	1.95±1.32**	1.33±1.06**	218.19±49.40*	0.23±0.75*	38.81±19.85*	0.94±0.70**	65.65±33.93*	10.77±3.10**

Means with the same superscript in the same row are not significantly different (p<0.05)

Table 3: Haematological parameters of *Clarias gariepinus* fingerlings fed processed baobab seed meal based diets for 56 days

Blood parameters	Initial values	DT1	DT2	DT3	DT4	DT5	DT6
PCV (%)	22.89±5.68	21.13±5.36*	21.40±3.14*	23.82±6.50**	27.50±3.90**	26.07±4.42**	21.50±1.30*
Hb (%)	8.92±1.26	7.02±1.79*	7.21±1.00*	8.61±3.31**	9.17±1.30**	8.67±1.45**	8.17±1.30**
RBC (x10 <sup>12</sup> /ml)	2.13±0.53	1.37±0.08*	1.36±0.07*	1.31±0.06**	1.67±0.14*	1.37±0.11*	1.49±0.08**
WBC (x10 <sup>9</sup> /ml)	3.26±0.53	3.03±0.55**	3.07±0.53**	2.63±0.55*	2.99±0.73**	2.70±0.33*	2.53±0.27*
MCV (fl)	10.75±1.01	15.35±1.13*	15.82±3.24*	15.71±3.57*	16.67±3.50*	19.07±3.78**	14.64±0.86**
MCH (pg)	4.19±1.10	5.10±1.13*	5.33±1.05*	5.66±1.91*	5.56±1.67*	6.34±1.23**	5.56±1.23**
MCHC (g/dl)	38.97±0.05	33.23±0.19*	33.16±1.42*	35.48±3.67*	33.34±0.03*	33.26±0.12*	33.33±0.02*

Means with the same superscript in the same row are not significantly different (p<0.05)

REFERENCES

Adewolu, M. O. A., C. A. Aderiji, and O. B. Adesoji (2008). "Feed utilization, growth and survival of *Clarias gariepinus* (Burchell 1822) fingerlings cultured under different photoperiods," *Aquaculture*, vol. 283, no. 1-4, pp. 64-67.

Alector, V. A. (1989). Effects of varying levels of fish meal substitution with soyabean meal on certain serum metabolites and haematological indices in the Chicken diets. *Nigeria Journal Technical Research* 1:111-114.

Alector, V. A. and Egberongbe, O. (1986). Feeding differently processed soyabeans and haematological indices in chicken diets. *5th Edition Journal of poultry science*, (3): 34-36.

Banerjee, S., Prashar, R., Kumar, A. and Rao, A. R. (2002). Modulatory influence of alcoholic extract of *Ocimum sanctum* on carcinogen metabolizing enzyme activities and reduced glutathione level in mouse. *Cancer*, 25: 205-217.

Bricknell, I. and R. A. Dalmo. (2005). "The use of immunostimulants in fish larval aquaculture," *Fish and Shellfish Immunology*, vol. 19, no. 5, pp. 457-472.

Chepkirui-Boit, V., C. C. Ngugi, J. Bowman et al., (2011) "Growth performance, survival, feed utilization and nutrient utilization of African catfish (*Clarias gariepinus*) larvae co-fed Artemia and a micro-diet containing freshwater atyid shrimp (*Caridina nilotica*) during weaning," *Aquaculture Nutrition*, vol. 17, no. 2, pp. e82-e89.

Costello, M. J. (2009). "The global economic cost of sea lice to the salmonid farming industry," *Journal of Fish Diseases*, vol. 32, no. 3, pp. 115-118.

De Caluwe, E., Halamova, K., Van Damme, P. (2010). *Adansonia digitata*: A review of traditional uses, phytochemistry and pharmacology. *Afrika focus*; 23: 11-51.



- de Graaf G. J. and H. Janssen, (1996). "Artificial reproduction and pond rearing of the African catfish, *Clarias gariepinus* in sub-Saharan Africa. A handbook," Tech. Rep. 362, *FAO Fisheries*, Rome, Italy, 1996. 6 ISRN Zoology.
- Elahee, K. B. and Bhagwant, S. (2007). Haematological and gill histopathological parameters of three tropical fish species from a polluted lagoon on the west coast of Mauritius. *Ecotox Environ. Saf.* 68: 362 – 371.
- Elkanem, S. B. (2001). Comparison haematological indices in Juvenile catfish, *Chrysichthys nigrodigitata*, fed complete and incomplete diets. *Global journal of pure and applied sciences*. Vol. 7, No. 2, 201-204.
- Erondu, E. S., C. Nnubia and F. O. Nwadu (1993). Haematological studies on four catfish species raised in freshwater ponds in Nigeria. *Journal of applied Ichthyology*. 9: 250 - 256.
- Feist S. W. and Longsham, M. (2000). Myxosporidiosis of fish and the Bryozoan link with proliferate kidney diseases (PKD) of Salmonids. *Journal of fish diseases* 1:91 - 108.
- Gebauer J, El-Siddig K, Ebert G (2002). Baobab (*Adansonia digitata* L.): A review on a multipurpose tree with promising future in the Sudan. *Gartenbauwissenschaft*, 67: 155-160.
- Golovina, N. A. (1996). Morpho-functional characteristics of the blood of fish as objects of aquaculture. PhD thesis. Moscow: University of Moscow.
- Grové and Naas (November 2011). "Redaksionele Kommentaar" (PDF). *Dendron* (43): 14. Retrieved 25 November 2015.
- Guillaume J., S. Kaushik, P. Bergot and R. Metailler. (2001). Nutrition and Feeding of Fish and Crustaceans. Publishing in associate with Praxis publishing, Chichester, UK408pp.
- Hankey, and Andrew (February 2004). "Adansonia digitata A. L.". *plantzafrica*. Retrieved 28 November 2015.
- Haylor, G. S. (1991). "Controlled hatchery production of *Clarias gariepinus* (Burchell 1822): growth and survival of fry at high stocking density," *Aquaculture and Fisheries Management*, vol. 22, no. 4, pp. 405–422.
- Hemre, G. I., K. Sonders, O. Torrissen and R. Waagebo, (1995). Carbohydrate nutrition in Atlantic salmon (*Salmo salar* L.): Growth and feed utilization. *Aquacult. Fish. Res.*, 26: 149-154.
- Hogendoorn, H. (1980) "Controlled propagation of the African catfish, *Clarias lazera* (C. and V.)—III. Feeding and growth of fry (Artemia)," *Aquaculture*, vol. 21, no. 3, pp. 233–241.
- Kelly, W. R., (1979). *Veterinary Clinical Diagnosis*. 4thEdn., BalliereTindall, London.
- Kestemont, P., I. Toko, E. D. Fiogbe, and B. Koukpode (2007) "Rearing of African catfish (*Clarias gariepinus*) and vundu catfish (*Heterobranchus longifilis*) in traditional fish ponds (whedos): effect of stocking density on growth, production and body composition," *Aquaculture*, vol. 262, no. 1, pp. 65–72, 2007.
- Lamb, G. M., (1981). *Manual of Veterinary Laboratory Techniques in Kenya*. Ministry of Livestock Development / CIBA GEIGY, Basle, Switzerland, pp: 96-107.
- Luskova, V. (1997). Annual cycles and normal values of haematological parameters in fishes. *Acta Sc. Nat. Brno.*, 31(5): 70-78.
- Naylor, R. L., Hardy, R. W., Bureau, D. P., Chiu, A., Elliot, M., Farrel, A. P., Forster, I., Gatlin, D. M., Goldburg, R. J., Hua, K. and Nichols, P. D. (2009). Feeding aquaculture in an era of finite resources. *Proceedings of National Academy of Science*. USA 106:15103-15111.
- Oluyemi, K. A., I. O. Omomiyi, Jimoh, O. R., Adesanya O. A., Saalu, C. L. and Josiah, S. J. (2007). Erythropoietic and anti-obesity effect of *Garcinia cambogia* (bitter kola) in Wistar rats. *Biotechnology Applied Biochemistry*, 46: 69-72.
- Olvera-Novoa, M. E., Camps, G. S., Sabido, G. M., Manitrinez-Palacios, C. A. (1990). Captured Fisheries and Aquaculture in Nigeria; A Comparative Economic Analysis. African Rural Social Sciences Series Report No. 13, *University Press LTD, Ibadan, Nigeria*. Pp. 291-293.
- Olvera-Novoa, M. E., Camps, G. S., Sabido, G. M., Manitrinez-Palacios, C. A. (1990). Captured Fisheries and Aquaculture in Nigeria; A Comparative Economic Analysis. African Rural Social Sciences Series Report No. 13, *University Press LTD, Ibadan, Nigeria*. Pp. 291-293.
- Oyelese, K. O., M. Turner, C. Lees and S. Campbell, (1999). Vasa previa: An avoidable tragedy. *Obstet. Gynecol. Surv.*, 54: 138-145.
- Palmer, E. and Pitman, N. (1972). Trees of southern Africa covering all known indigenous species in the Republic of South Africa,

- South-West Africa, Botswana, Lesotho and Swaziland. Cape Town, AA Balkema.
- Schalm, O. W., N. C. Jain and E. J. Carroll, (1975). *Veterinary Haematology*. 3rd Edn., Lea and Fabiger, Philadelphia, pp: 15-218.
- Sibibe, M. and Williams, J. T. (2002). Baobab – *Adansonia digitata*. Fruits for the future. *Int. Centre Underutil. Crops*, Southampton, UK, 96 p.
- Sogbesan, O. A., (2006). Effects of different organic substrates on growth and survival of long winged termite (*Macrotermes subhyabrius*) under laboratory conditions. *Afr. J. Gen. Agric.*, 2 (2): 3744.
- Van Vuren, J. H. J. (1986). The effects of toxicants on the haematology of *Labeo umbratus* (Teleostei; Cyprinidae). *Comparative Biochemistry and Physiology*, 83C: 155-159.
- Wickens, G. E. and Lowe, P (2008). The Baobabs: Pachycauls of Africa, Madagascar and Australia: The Pachycauls of Africa, Madagascar and Australia: *Springer*.
- Woo, P. T. K. (2006). "Fish diseases and disorders," in *Protozoan and Metazoan Infections*, P. T. K. Woo, Ed., vol. 1, pp. 46–114, CAB International, Oxfordshire, UK, 2nd edition, 2006.
- Woodborne and Stephan, Dr. (2015). "Dating Africa's giants reveals far more than just age". *CSIR*. Retrieved 25 November 2015.

## EFFECTS OF BIOCHAR AND NITROGEN FERTILIZER ON SELECTED SOIL PHYSICAL PROPERTIES AND MAIZE YIELD AT MINNA, NIGERIA

Azeez<sup>1\*</sup>, B. A., A. J. Odofin<sup>1</sup>, M. O. Kareem<sup>1</sup> And B. M. Musa<sup>1</sup>

<sup>1</sup> Department of Soil Science and Land Management, Federal University of Technology, Minna, Niger State

\*Corresponding Author's E-mail: [azeezbasit01@gmail.com](mailto:azeezbasit01@gmail.com), GSM: [07037919647](tel:07037919647)

### ABSTRACT

*This study was conducted to evaluate the effect of biochar in combination with nitrogen fertilizer on selected soil physical properties and maize yield at the Teaching and Research Farm of the Federal University of Technology, Minna. Biochar used in the study was produced from camel foot (*Piliostigmareticulatum*) and bilinga (*Naucleasp*). The trial was a 3 x 4 factorial experiment arranged in a randomized complete block design (RCBD) with three levels of biochar (0, 2.5 and 5 t/ha) and four levels of nitrogen fertilizer (0, 40, 80 and 120 kg N/ha) with urea as the source and replicated three times to give a total of thirty-six experimental field plots. Soil and plant data collected were subjected to analysis of variance (ANOVA) and significant means were separated using Least Significant Difference (LSD). The results indicated that the application of fertilizer and biochar showed non-significant ( $P \leq 0.05$ ) change in soil bulk density and soil moisture constants (including SC, FC, PWP and AWC) among the different rates of treatment application. Fertilizer and biochar application had no significant effect on seedling emergence. Application of nitrogen fertilizer alone had significant ( $p \leq 0.05$ ) effect on plant height, stover and grain yields of maize. Application of 120 and 80 kg N/ha gave highest plant height and control gave the least. Application of nitrogen fertilizer significantly ( $p \leq 0.05$ ) enhanced height, stover and grain yields of maize proportional to the rate of application.*

**KEYWORDS:** Biochar, Nitrogen fertilizer, Soil bulk density, Moisture constants

### INTRODUCTION

Nigeria, blessed as it is, with abundant agro-ecological resources and diversity, has become one of the largest food importers in sub-Saharan Africa (Idachaba, 2009). In the quest to overcome this challenge, farmers have resorted to intensively cultivating their lands year after year and this has led to a decline in soil quality through nutrient mining and loss of organic matter (Oshunsanya and Aliku, 2012). Measures that can be taken to compensate for the drastic loss of soil nutrients include; among others, application of manure (organic and / or inorganic) and soil amendment such as biochar. In most parts of Africa including Nigeria, the traditional method of maintaining soil fertility and productivity has been bush-fallow system where the arable land is allowed to revert to fallow after 3 – 4 years of continuous cultivation. However, due to the growing population and other socio-economic pressures, the fallow period had been reduced now to almost no fallow in order to accommodate the increasing high demand for food (Asadu and Unagwu, 2012). Alternatively, the use of both organic and inorganic fertilizers by farmers has been reported to enhance yield and sustain soil productivity (Olatunji and Ayuba, 2012; Chukwuet *al.*, 2012). This has also had limited success because of its loss through rapid mineralization and the need to apply same every year (Omotayo and Chukwuka, 2009; Agbede and Adekiya, 2015). Several researches have shown that

biochar (a carbon rich material produced from pyrolysis of various materials in the absence of oxygen which can be made from any biomass feedstock including wood, rice husk, maize residues, poultry litter and cocoa husk) is recalcitrant and does not require annual application (Shindo, 1991; Lehmann and Joseph, 2009). Over the years, Nigerian government has popularized the use of inorganic fertilizers in order to improve crop yield but the risk of soil degradation from its continuous use, increasing cost of procurement and late supply are some of the constraints encountered by farmers (Chudeet *al.*, 2012). This research aims to assess the impact of biochar (as a substitute for organic manure) on soil productivity which may in turn lead to a reduction in inorganic fertilizer use for maize production in Nigeria. Objectives were to evaluate the effect of biochar in combination with nitrogen fertilizer on (i) soil bulk density, saturation capacity, field capacity, permanent wilting point and available water capacity (ii) seedling emergence, plant height, stover and grain yields of maize.

### METHODOLOGY

#### Site Description

The study was carried out at the Teaching and Research Farm of the School of Agriculture and Agricultural Technology, Federal University of Technology, Minna. The study area is located between latitudes  $9^{\circ} 30' 30.10''$  and  $9^{\circ} 31' 2.92''$  and longitudes  $6^{\circ} 25' 57.61''$  and  $6^{\circ} 27' 2.00''$  at elevation



ranging from 190 to 216 m above the sea level in the Southern Guinea savanna zone of Nigeria (Odofoin, 2017). It is sub-humid with annual rainfall of 1,284 mm from April to October and a district dry season of about 5 months occurring from November to March with an average temperature of about 33 °C (Ojanuga, 2006).

### Biochar Production

The biochar used in this study was produced using camel foot (*Piliostigmareticulatum*) and bilinga (*Naucleasp*). These shrubs were sourced from adjoining fallow lands.. The feedstock (which included roots, stems and leaves of the plants) was sundried for about one week and later converted to biochar by heating using the traditional earthen mound kiln method (without energy capture) in which the earth was used to regulate the amount of oxygen at an average temperature of about 400°C within the kiln.

### Experimental Design

The trial was a 3 x 4 factorial experiment arranged in a randomized complete block design (RCBD) with three levels of biochar (0, 2.5 and 5 t/ha) and four levels of nitrogen (0, 30, 60, 120 kg N/ha) using urea as the source. This was replicated three times. A total of thirty-six plots, each measuring 4 x 4 m were used for the experiment. Plots were separated by a buffer of 1 m and the replicates were 3 m apart.

### Cultural Practices

Biochar was broadcast on each plot and manually incorporated into the topsoil using a hoe two weeks before seed planting and urea was applied by side placement at 2 and 6 weeks after sowing. Two maize seeds (Variety- Oba super II) were sowed per hole at a depth of about 3 cm and spacing of 75 x 25 cm (intra and inter row) on ridges made using hoe. The seedlings were thinned to one plant per stand at 2 weeks after sowing. Weeding was carried out manually using hoe at 2 and 6 weeks after sowing. Also, the crop was raised under rain-fed system and allowed to dry before harvested.

### Soil Sampling, Preparation and Analysis

Initial soil samples were collected randomly from the site at 0 – 15 cm depth before the experiment. The samples were thoroughly mixed to form a composite soil sample from which a sub-sample was taken, air-dried, gently crushed and passed through 2 mm sieve to obtain fine earth separates. The processed soil sample was analysed for routine parameters following IITA (1982) routine procedures. Briefly, particle size distribution was determined using hydrometer method. The soil pH was measured in a soil-water ratio of 1:2 with glass electrode pH meter and organic carbon using Walkley-Black method. Total nitrogen was determined by micro-Kjeldahl

process, available phosphorus by Bray P-1 method and exchangeable bases (Ca<sup>2+</sup>, Mg<sup>2+</sup>, K<sup>+</sup> and Na<sup>+</sup>) were extracted using 1 N NH<sub>4</sub>OAC buffered at pH 7.0. Ca<sup>2+</sup> and Mg<sup>2+</sup> in the extract were determined using atomic absorption spectrophotometer while K<sup>+</sup> and Na<sup>+</sup> were estimated using flame photometer. Exchangeable acidity (Al<sup>3+</sup> and H<sup>+</sup>) was extracted with 1 N KCl and determined by titration with 0.5 N NaOH using phenolphthalein as indicator. Effective cation exchange capacity (ECEC) was estimated by summation of total exchangeable bases and total exchangeable acidity. After the study, undisturbed samples were taken randomly from each plot and were used to determine bulk density (using the core method) (Blake and Hartage, 1986) and soil moisture constants including saturation capacity (SC), field capacity (FC), permanent wilting point (PWP) and available water capacity (AWC). To determine saturation capacity, undisturbed soil samples were randomly collected from a depth of 0 – 15 cm in each plot at 16 weeks after planting. The samples were saturated overnight for 24 hours by covering one end of the rings with piece of cloth and holding the cloth tightly using rubber bands. These rings were then transferred into an empty bowl with the covered side placed at the base of the bowl; water was poured into the bowl so that the rings were not submerged. The saturated samples were weighed after which they were oven-dried at 105 °C for 48 hours to constant weight. SC was then calculated thus:

$$SC = \frac{m_1 - m_2}{m_2 - m_3} \times 100$$

Where:

m<sub>1</sub> = mass of saturated soil + core ring  
m<sub>2</sub> = mass of oven-dried soil + core ring  
m<sub>3</sub> = mass of empty core ring

Amount of water at FC and PWP was estimated using the saturation water percentage-based models (Mbagwu and Mbah, 1998):

$$FC = 0.79(SC) - 6.22 \quad (r = 0.972)$$

$$PWP = 0.51(SC) - 8.65 \quad (r = 0.949).$$

AWC was calculated as the difference between water contents at FC and PWP.

### Agronomic Parameters

The following agronomic data were collected

#### Seedling Emergence

At 2 weeks after planting, the number of seedlings that emerged was counted per plot and expressed as a percentage of the number of expected seedlings per plot.

#### Plant Height

Ten maize plants per plot were sampled at 16 weeks after sowing, measured from ground surface to the tip of the plant using a measuring tape and the results were expressed in cm.

#### **Stover Yield**

Stover yield was determined after harvesting the crop. The leaves, stem, husk and cobs (after shelling), were weighed and expressed in t/ha.

#### **Grain Yield**

At maturity, cobs from the inner rows were harvested, sun-dried (13 – 14% moisture content), threshed and grains weighed per plot and expressed in t/ha.

#### **Statistical Analysis**

Statistical analysis of the data was carried out using the General Linear Model of SAS software for randomized complete block (RCBD) while significant treatments means were separated using Least Significant Difference (LSD).

## **RESULTS AND DISCUSSION**

### **Initial Soil Characteristics**

The initial soil characteristics of the study area are presented in Table 1. The textural class is sandy loam. The pH (in water) was strongly acidic (5.4). Organic carbon and total nitrogen (3.80 and 0.11 g/kg) were very low. ECEC (10.09 cmol/kg) and available phosphorus (6.89 mg/kg) were low. Sodium, Potassium, magnesium and calcium (ranged from 0.26 – 6.00 cmol/kg) were low to high. These properties characterize a typical savanna soil as recorded by other authors (Lawalet *et al.*, 2013; Afolabiet *et al.*, 2014; Lawalet *et al.*, 2014).

### **Chemical Properties of Biochar Used in the Study**

The chemical properties of biochar used in the study are presented in Table 2. The pH (in water) was strongly alkaline (8.30). Values for N and P (0.90 and 1.70 %), were low while K, Mg and Ca (2.74, 3.08 and 3.54 %) were high. ECEC (96.09 cmol/kg) and organic carbon (63.5 %) were high to very high. A unique characteristic of biochar is high C: N ratio. Biochar used in this study has a C: N ratio of 70.5 which is consistent with those produced by other authors. Fagbenroet *et al.* (2013) produced biochar from saw dust with C: N of 80.4. Similarly, Fagbenroet *et al.* (2018) produced biochar from *Gliricidia* with C: N of 86.7.

### **Main and Interaction Effects of Biochar on Selected Soil Physical Properties**

The main and interaction effects of biochar in combination with nitrogen fertilizer on selected soil physical properties are presented in table 3. The application of fertilizer and biochar showed non-significant ( $P \leq 0.05$ ) change in soil bulk density and moisture constants (including SC, FC, PWP and AWC) among the different rates of treatment

application. This might be due to the low quantity of biochar applied. Githinji (2013) concluded that by increasing the rate of biochar application, bulk density was also significantly decreased because porosity of biochar is very high and when it used in soil it significantly decrease bulk density by increasing the pore volume. Control (for fertilizer and biochar) recorded the highest PWP of 0.05 g/g while that of fertilizer and biochar treated plots ranged between 0.03 – 0.04 g/g. This result commensurates with that of Njoku *et al.* (2015) who reported similar non-responsiveness of soil physical properties to different levels of biochar application.

### **Main Effects and Interactions of Biochar and Nitrogen Fertilizer on Seedling Emergence, Plant Height, Stover Yield and Grain Yield of Maize**

The main and interaction effects of biochar in combination with nitrogen fertilizer on seedling emergence, plant height, stover yield and grain yield of maize are presented in table 4. Fertilizer and biochar application had no significant effect on seedling emergence. Although, fertilizer application had significant ( $p \leq 0.05$ ) effect on plant height, stover and grain yields of maize. Application of 120 and 80 kg N/ha gave highest plant height and control gave the least. 120 kg N/ha produced highest stover yield (5.28 t/ha) which was not significantly different from 80 kg N/ha. Grain yield increased proportional to the rate of fertilizer application. The beneficial effect of inorganic fertilizer on maize growth may be due to the positive effect of nitrogen that was contained in the fertilizer which resulted in the vigorous growth and grain yield of maize (Asaiet *et al.*, 2009; Zhang *et al.*, 2011; Fagbenroet *et al.*, 2018; Babatolaet *et al.*, 2006). Also, Table 4 shows that application of biochar alone had no significant effect on height, stover and grain yields of maize. This might be due to crop response to biochar amendment, which depends on the chemical and physical properties of the biochar, crop type, soil and climatic conditions (Zhang *et al.*, 2011; Fagbenroet *et al.*, 2018). Similarly, negative yield responses of crops to biochar application had also been reported (Chan *et al.*, 2007; Asaiet *et al.*, 2009).

## **CONCLUSION AND RECOMMENDATIONS**

Biochar, inorganic fertilizer as well as their interaction had no significant effect on the soil physical properties. Application of nitrogen fertilizer significantly enhanced height, stover and grain yields of maize proportional to the rate of application. 5 t/ha of biochar was the maximum rate of application in this trial. Thus, higher rates of application should be investigated on soil physical properties. Also, more research should be carried out to study the effects of

biochar on the chemical and biological properties of the soil.





Table 1: Initial soil characteristics

Soil Properties	Values
<b>Particle Size Distribution (g/kg)</b>	
Sand	792
Silt	33
Clay	175
Texture	Sandy Loam
pH (H <sub>2</sub> O) <sup>a</sup>	5.40
Organic Carbon (g/kg)	3.80
Total Nitrogen (g/kg)	0.11
Available Phosphorus (mg/kg)	6.89
<b>Exchangeable Bases (cmol/kg)</b>	
Ca	6.00
Mg	2.53
K	0.35
Na	0.26
Exchangeable Acidity (cmol/kg)	1.02
ECEC (cmol/kg)	10.09

<sup>a</sup>Measured in 1:2 soil: water ratio, ECEC = effective cation exchange capacity

Table 2: Chemical properties of Biochar used

Property	Value
pH (H <sub>2</sub> O) <sup>a</sup>	8.30
Organic Carbon (%)	63.5
Total Nitrogen (%)	0.90
Phosphorus (%)	1.70
Ca (%)	3.54
Mg (%)	3.08
K (%)	2.74
ECEC (cmol/kg)	96.09

<sup>a</sup>Measured in 1:2 soil: water ratio

	Bulk density (g/cm <sup>3</sup> )	SC (g/g)	FC (g/g)	PWP (g/g)	AWC (g/g)
<b>Biochar (B)</b>					
(t/ha)					
0	1.59	0.22	0.12	0.05	0.08
2.5	1.61	0.22	0.11	0.03	0.08
5	1.59	0.22	0.11	0.03	0.09
SE ±	0.045	0.009	0.007	0.011	0.003
<b>Fertilizer (F) (kg N/ha)</b>					
0	1.61	0.22	0.11	0.05	0.08
40	1.56	0.22	0.12	0.04	0.08
80	1.58	0.23	0.12	0.03	0.09
120	1.62	0.21	0.11	0.03	0.08
SE ±	0.053	0.010	0.008	0.012	0.003

Interaction					
B×F	NS	NS	NS	NS	NS

Table 3: Main Effects and Interactions of Biochar and Nitrogen Fertilizer on Selected Soil physical Properties

Means in a column within a treatment with the same letter are not significantly different at 5% level of probability. NS = Not significant, SE ± = Standard error, SC = saturation capacity, FC = field capacity, PWP = permanent wilting point, AWC = available water capacity.

Table 4: Main Effects and Interactions of Biochar and Nitrogen Fertilizer on Seedling Emergence, Plant Height, Stover Yield and Grain Yield of Maize.

	Seedling emergence (%)	Plant height (cm)	Stover yield (t/ha)	Grain yield (t/ha)
<b>Biochar (B) (t/ha)</b>				
0	81.00	184.03	3.75	1.28
2.5	81.00	173.79	4.10	1.27
5	80.00	177.22	4.31	1.36
SE ±	1.577	4.459	0.317	0.120
<b>Fertilizer (F) (kg N/ha)</b>				
0	81.00	134.09 <sup>c</sup>	2.08 <sup>c</sup>	0.12 <sup>d</sup>
40	82.00	178.82 <sup>b</sup>	3.95 <sup>b</sup>	1.13 <sup>c</sup>
80	79.00	198.98 <sup>a</sup>	4.90 <sup>ab</sup>	1.70 <sup>b</sup>
120	80.00	201.45 <sup>a</sup>	5.28 <sup>a</sup>	2.26 <sup>a</sup>
SE ±	1.821	5.149	0.366	0.138
<b>Interaction</b>				
B×F	NS	NS	NS	NS

Means in a column within a treatment and followed by different letter are significantly different at  $p \leq 0.05$ . SE ± = Standard error, NS = Not Significant.

## REFERENCES

- Afolabi, S. G., Adeboye, M. K.A., Lawal, B. A., Adekanmbi, A. A., Yusuf, A. A., & Tsado, P. A. (2014). Evaluation of Some Soils of Minna Southern Guinea Savanna of Nigeria for Arable Crop Production. *Nigerian Journal of Agriculture, Food and Environment*, 10(4), 6 – 9.
- Agbede, T. M. & Adekiya, A. O. (2015). Effects of Poultry Manure and NPK Fertilizer on Soil Physical Properties, Growth and Yield of Carrot (*Daucus carota* L.). *Proceedings of the 39<sup>th</sup> Annual Conference of the Soil Science Society of Nigeria*, March 9 – 13<sup>th</sup>, 2015, Landmark University, Omu-Aran, Kwara State.
- Asadu, C. L. A. & Unagwu, B. O. (2012). Effect of combined Poultry Manure and inorganic fertilizer on maize performance in an ultisol of southeastern Nigeria. *Nigeria Journal of Soil Science*. 22(1) 79 – 87.
- Asai, H., Samson B. K., Stephan, H. M., Songyikhangsuthor, K., Homma, K., Kiyono, Y., Inoue, Y., Shiriwa, T., Horie, T. (2009). Biochar Amendment Techniques for Upland Rice Production in Northern Laos 1. Soil Physical Properties, Leaf SPAD and Grain Yield. *Field Crop Research*, 111: 81 – 89.
- Babatola, L. A. (2006). Effect of NPK 15:15:15 on the performance and storage life of okra (*Abelmoschus esculentus*). *Proceedings of the Horticultural Society of Nigeria Conference*, pp: 125-128.
- Blake, G. R., & Hartage, K. H. (1986). Bulk density. In A. Klute (Ed), *Methods of Soil Analysis part 1*, *American Society of Agronomy*, No 9 Madison, Wisconsin, 365 – 375.
- Chan, K. Y., Zwieten, V. L., Meszaros, I., Downie, A. & Joseph, S. (2008). Using Poultry Litter Biochar as Soil Amendments. *Australian Journal of Soil Research*, 46:437 – 444.
- Chude, V. O., Olayiwola, S. O., Daudu, C., & Ekeoma, A. (2012). *Fertilizer Use and Management Practices for Crops in Nigeria*. (4<sup>th</sup>ed). Abuja: Federal Ministry of Agriculture and Rural Development (FMARD).
- Chukwu, L. I., Ano, A. O., & Asawalam, D. O. (2012). Effects of Poultry Manure and NPK fertilizer on soil properties and Nutrient uptake of maize (*Zea mays* L.), plants growth in an ultisol. *Proceedings of the 36<sup>th</sup> Annual Conference of the Soil Science Society of Nigeria (SSSN)* on 7<sup>th</sup> – 11<sup>th</sup> March, 2012 University of Nigeria Nsukka.
- Fagbenro, J. A., Oshunsanya, S. O. & Onawumi, O.A. (2013). Effect of Saw Dust Biochar and NPK 15:15:15 Inorganic Fertilizer on *Moringa oleifera* Seedlings Grown in an Oxisol. *Agrosearch*, 13(1): 57 – 68.
- Fagbenro, J. A., Oshunsanya, S. O., Oyeleye, B. & Aduayi, E. A. (2018). Effect of Two Biochar Types and Inorganic Fertilizer on Soil Chemical Properties and Growth of Maize (*Zea mays* L.). *International Educational Scientific Research Journal*, 4(2): 43 – 50.
- Githinji, L. (2013). Effect of Biochar Application Rate on Soil Physical and Hydraulic Properties of a Sandy Loam. *Archives of Agronomy and Soil Science*, 1 – 14.
- Idachaba, F. S. (2009). The Looming Food Crisis, *Newswatch*, Lagos, (August 3), *Special Colloquium Edition*.
- IITA (International Institute for Tropical Agriculture), (2012). *Research to Nourish Africa*, Pp 7 – 10.
- Lawal, B. A., Adeboye, M. K. A., Odofin, A. J. & Ezenwa, M. I. S. (2014). Assessment of Properties and Agricultural Potentials of Some Hydromorphic Soils in Katcha Local Government Area of Niger State, Nigeria. *Nigerian Journal of Technological Research*, 9(2), 1 – 6.
- Lawal, B. A., Ojanuga, A. G., Tsado, P. A., & Mohammed, A. (2013). Characterization, Classification and Agricultural Potential of Soils on a Toposequence in Southern Guinea Savanna of Nigeria. *International Journal of Agricultural and Biosystems Engineering*, 7(5), 1307 – 1312.
- Lehmann, J., & Joseph, S. (2009). Biochar for environmental management: Science and



- Technology. *Earthscan, London and Sterling, VA.* 416p.
- Mbagwu, J. S. C., & Mbah, C. N. (1998). Estimating Water Retention and Availability of Soils from their Saturation Percentage. *Communication in Soil Science and Plant Analysis*, 29, 913–922.
- Njoku, C., Mbah, C. N., Igboji, P. O., Nwite, J. N., Chibuike, C. C., & Uguru, B. N. (2015). Effect of Biochar on Selected Soil Physical Properties and Maize in an Ultisol in Abakaliki Southeastern Nigeria. *Global Advanced Research, Journal of Agricultural Science*, 4(12), 864 – 870.
- Odofin, A. J. (2017). Nigerian Soil Resources: The Neglected Base of our National Development. Federal University of Technology, Minna. *Inaugural Lecture, Series 56*.
- Ojanuga, A. G. (2006). Agroecological Zones of Nigeria Manual. FAO/NSPFS, Federal Ministry of Agriculture and Rural Development, Abuja, Nigeria, 124 pp.
- Olatunji, O., & Ayuba, S. A. (2012). Effect of combined applications of poultry manure Soil, Doi 10. 1007/s11104-0110957x and NPK 20-10-10 fertilizer on soil chemical properties and yield of maize (*Zea mays L.*). *Proceedings of the 35th Annual Conference of the Soil Science Society of Nigeria (SSSN)*, 7th – 11th March, 2011, Federal University of Technology Minna.
- Omotayo, O. E., & Chukwuka, K. S. (2009). Soil Fertility Restoration Techniques in Sub-Saharan Africa Using Organic Resources. *African Journal of Agricultural Research*, 4(3), 144 – 150.
- Oshunsanya, S. O. & Aliku H. (2012). Soil Erodibility as Influenced by Long Term Fallow in Southwestern Nigeria. *Paper delivered at West African Summit on Organic Agriculture (WASUMIT)*, 2, 45 – 53.
- Shindo, H. (1991). Elementary Composition, Humus Composition, and Decomposition in Soil of Charred Grassland Plants. *Soil Science and Plant Nutrition*, 37, 651 – 657.
- Zhang, A., Yuming, L., Genxing, P., Qaiser, H., Lianqing, L., Jinwei, Z. & Xuhui, Z. (2011). Effects of Biochar Amendment on Maize Yield and Greenhouse Gas Emissions from a Soil Organic Carbon Poor Calcareous Loamy Soil from Central China Plain. *Plant*

# EFFECTS OF RAINFALL ON FISH COMMUNITY STRUCTURE IN AGAIE-LAPAI DAM RESERVOIR OF NIGER STATE, NIGERIA

Yakubu, U. P<sup>1</sup>., Yusuf, J<sup>1</sup> and Yusuf, M<sup>2</sup>.

1. Federal University of Technology, Minna.
2. Ibrahim Badamasi Babangida University, Lapai.

Correspondence: email: umar.yakubu@futminna.edu.ng

Phone number: 08022070614

## ABSTRACT

The effects of rainfall on fish biodiversity in Agaie-lapai dam reservoir were studied by monthly samplings and measurements taken from 2013 to 2014. The reservoir is situated at 9° 39' N latitudes and 6° 33' E longitudes located near Bakaje at the confluence of the Jatau River. The reservoir was constructed for irrigation, fisheries and tourism purposes. Samples of fish was collected from the fishermen in two landing sites where catches were done using cast nets, seine nets and hooks and lines in designated stations. Eleven families were identified during the study belonging to Brigididae 2 species, Characidae 2 species, Schilbeidae 2 species, Cichlidae 5 species, Clariidae 2 species, Cyprinidae 3 species, Chanidae, Hepsetidae, Malapteruridae, Mochokidae and Mormyridae had 1 species each respectively. The species diversity was at its peak in the wet season, coinciding with favourable conditions such as highwater level and abundance natural food. The reverse was the case in the dry period as a result of low level of the water in the reservoir, insufficient food items and uncontrolled fishing practices. The highest species richness value (1.08) was recorded for Schilbeidae while the lowest record of (0.56) value for Hepsetidae. Lapai dam reservoir is a small, unpopular, unmanaged and unmonitored. To correct these abnormalities, an urgent need to reverse the trend by government is paramount.

KEY WORDS: Hydrological factors, Fish biodiversity, Fish fauna and Species diversity.

## INTRODUCTION

The role of diversity index in the structure of fish communities in lakes and reservoirs has been the focus of many studies (Castillo-Rivera, 2013). These studies have shown changes in species diversity which may be influenced by constant fluctuations in hydrological factors such as rainfall, inflow rate of water and the depth of the reservoirs (Zarate-Hernandez *et al.*, 2012). Fisheries and aquaculture sectors are crucial to food security, poverty alleviation and wellbeing of the developed and developing countries of the world. It forms the administrative policy of most government of the developing countries including Nigeria (Olashinde and Abeke, 2010).

## MATERIALS AND METHODS

### Study Area

Agaie/ Lapai dam is located at latitude 9°39'N and longitude 6° 33'E southwest of Minna. It has a capacity of 38 million cubic meters and a crest length of 1.600 meters. Its average depth is about 10.8 meters and becomes progressively shallower towards the inflow part, where it measures less than 1.64 meters. The shore is not easily accessible during wet season. There are three tributaries and then one spillway on the side of the embankment of the dam.

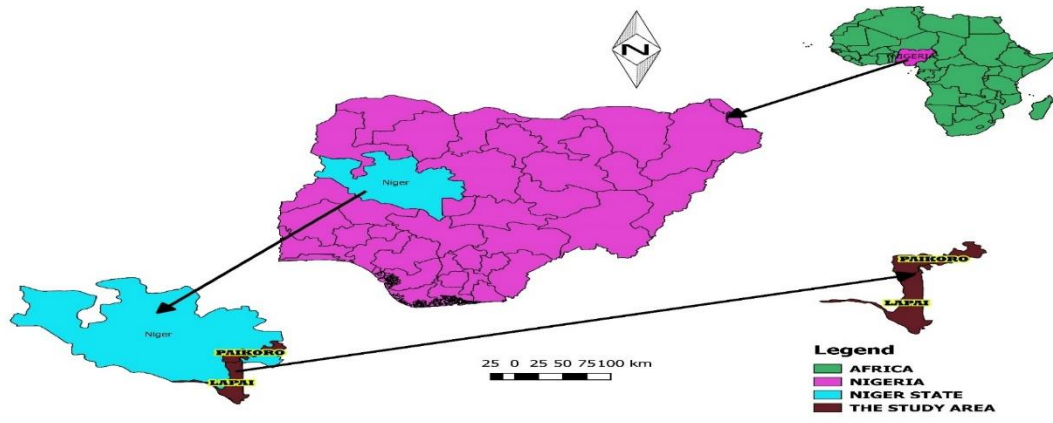


Figure 1: The location of Lapai dam reservoir (inset map of Nigeria and Africa)

**Measurement of rainfall:** Daily rainfall measurement was taken using standard rain gauge stationed at the dam site.

**Sampling: Fish sampling**

Samples of fish were collected from the fishermen into two chosen landing sites (Bakajiba and TuganGana) southwest and Northeastern part of the reservoir respectively. Fishermen caught fishes with castnets, seine nets and hooks and lines. Passive net was set in the designated sampling stations in the reservoir. The fishes collected were brought to laboratory and preserved in 10 % formalin solution in separate specimen jars according to the size of fish species. Small fishes were placed in 10 % formalin directly, while larger fishes were given an incision of formalin in their abdomen and preserved. The fishes were identified following the procedures and description contained in the standard books and keys.

**Community structure Analysis:** The calculations of all the indices were done online at

[http://www.alyoung.com/labs/biodiversity\\_calculation.html](http://www.alyoung.com/labs/biodiversity_calculation.html)

**Water Physical and Chemical parameters**

Water physical and chemical parameters were measured following the methods described by the American Public Health Association (APHA, 2008).

**RESULTS**

**Fish species composition and abundance**

The total results of the abundance of fish species per month from May, 2013 to October, 2014 in Lapai reservoir. The result shows *Tilapia zillii* had the highest number of four thousand, nine hundred and seventy-five (4975) individual species and distantly followed by *Hemichromis fasciatus* with one thousand six-hundred and fifty-six species. The least species counted within the period were *Hepsetus odoe*, *Malapterurus electricus*, *Schilbeuranoscopus*, and *Labeo senegalensis* with ten (40), thirty-two (56), thirty-nine (63) and one hundred and nineteen (119) species. The species were grouped into eleven families and twenty-three genera (Table 2).



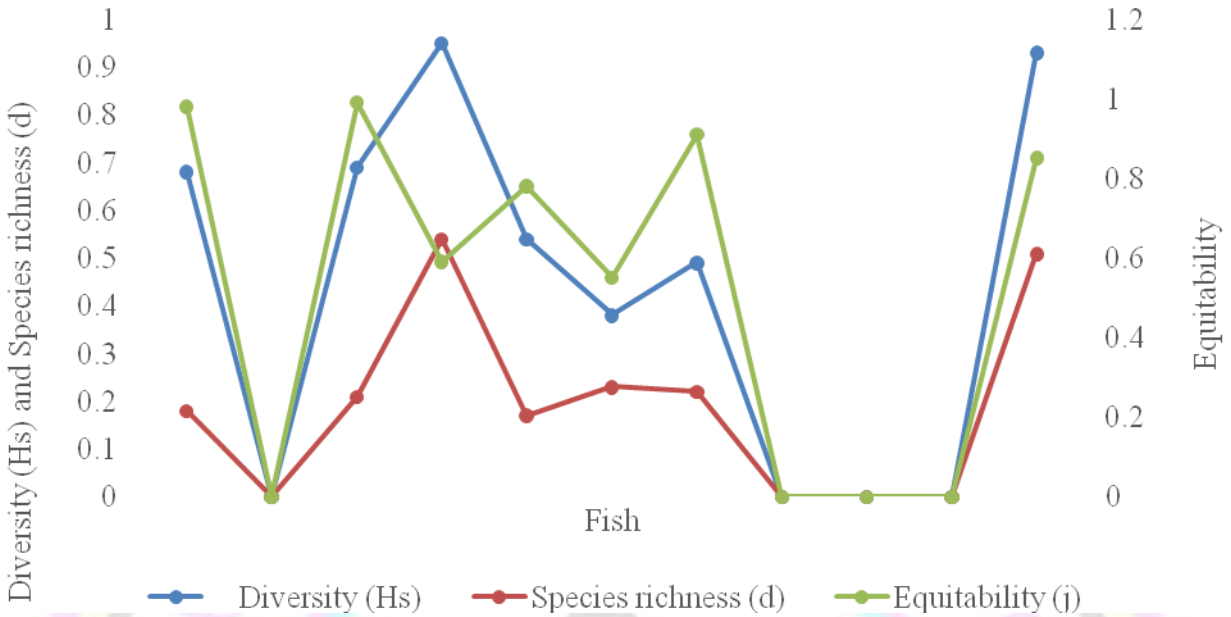
**Table 2: Fish composition in Lapai dam reservoir between May, 2013 and October, 2014**

Fish family	Genus	Species	Abundance	Percentage
Bagridae	<i>Auchanoglanis</i>	<i>occidentalis</i>	679	4.6
	<i>Bagrus</i>	<i>bayad</i>	517	3.5
Chanidae	<i>Parachanna</i>	<i>obscura</i>	513	3.45
Characidae	<i>Alestes</i>	<i>macrophthalmus</i>	597	4
	<i>Micralestes</i>	<i>elongates</i>	320	2.15
Cichlidae	<i>Hemichromis</i>	<i>faciatus</i>	1,656	11.14
	<i>Hemichromis</i>	<i>bamaculatus</i>	335	2.25
	<i>Oreochromis</i>	<i>niloticus</i>	677	4.55
	<i>Tilapia</i>	<i>zilli</i>	4,975	33.48
Clariidae	<i>Sarotherodon</i>	<i>galilaeus</i>	514	3.45
	<i>Clarias</i>	<i>gariepinus</i>	517	3.5
	<i>Heterobranchus</i>	<i>bidorsalis</i>	144	0.96
Cyprinidae	<i>Garra</i>	<i>waterloti</i>	214	1.44
Hepsetidae	<i>Labeo</i>	<i>senegalensis</i>	119	0.8
	<i>Raiamas</i>	<i>senegalensis</i>	162	1.09
Hepsetidae	<i>Hepsetus</i>	<i>odeo</i>	40	0.27
	<i>Hepsetus</i>	<i>pictus</i>	472	3.18
Malapteruridae	<i>Malapterurus</i>	<i>electricus</i>	56	0.37
Mochokidae	<i>Synodontis</i>	<i>nigrita</i>	1,227	8.25
Mormyridae	<i>Mormyrus</i>	<i>rume</i>	239	1.6
Schilbeidae	<i>Petrocephalus</i>	<i>soudanensis</i>	496	3.3
	<i>Petrocephalus</i>	<i>bane</i>	327	2.3
	<i>Schilbe</i>	<i>uranoscopus</i>	63	0.42
		<b>TOTAL</b>	<b>14,859</b>	<b>100</b>

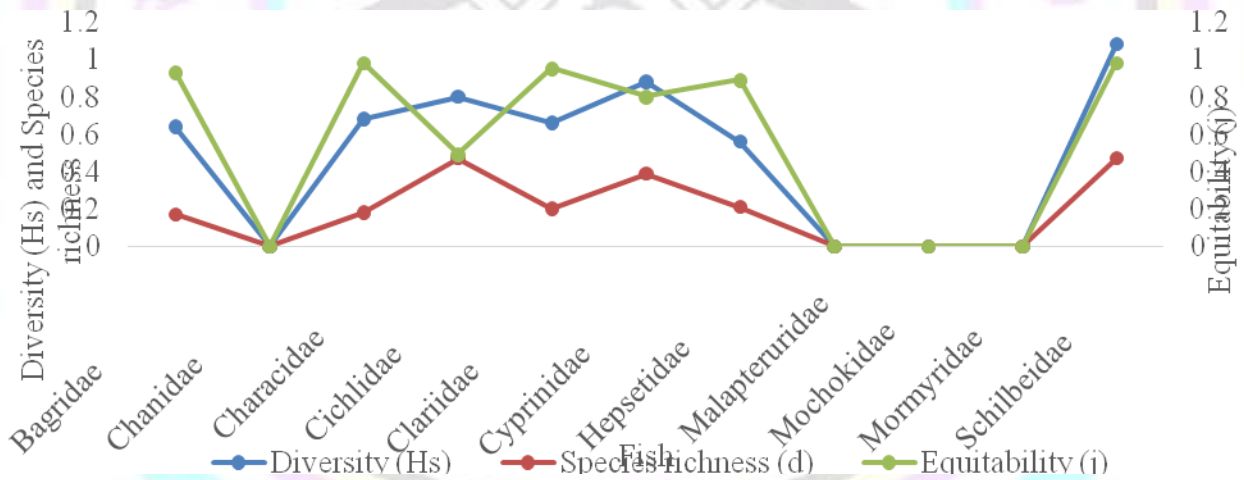
#### Fish diversity and species richness in Lapai dam reservoir

The diversity of the family of fish in Lapai dam reservoir reveal variations in the Margalef species richness and Shannon/Weaver values between 0.17 and 0.54, and 0.38 and 0.95 (Table3). The lowest value for species richness was recorded for the family

of Claridae, while the highest was recorded for Cichlidae. The diversity values showed that the family of Cyprinidae had the lowest value and the highest value was recorded for the family of Cichlidae.



**Figure 1: Biodiversity of fish in Lapai dam reservoir in the wet season of 2013**



**Figure 2: Biodiversity of fish in Lapai dam reservoir of the dry season in 2013**

## DISCUSSION

The role of diversity in the structuring of fish communities in lakes and reservoirs has been the focus of many studies (Perbiche-Neves *et al.*, 2012; Zhou *et al.*, 2012; Adesalu, 2013; Veradharajan and Soundarapandian, 2013; Dimowo, 2013, and Dalal and Gupta, 2013). These studies have shown changes in species diversity which may be influenced by constant fluctuations of rainfall. The family like the

Schilbeidae and Cichlidae were more dominant. This is in contrast with the findings of Thirumala *et al.*, 2011, who reported the species of *Cirrhinus*, *Salmostoma*, *Rasbora* and *Puntius* to be more dominant in Bhadra reservoir in India. The species of Schilbeidae and Cyprinidae were highly diversified in the dry period whilst the species richness of Cichlidae and Schilbeidae top the groups studied. In contrast, Castillo-Rivera, 2013, identified *Anchoamitchilli*, *Oreochromis mossambicus* and

Anchoafelis as the most abundance and diversified in a Tropical Estuary, Mexico.

## CONCLUSION

There are rich diverse cultivable species of fish in the reservoir. These species are in numerous small reservoirs across the country which should be incorporated into the value system of Nigeria society.

## RECOMMENDATIONS

- i. Regular fish stock assessment should be mentained.
- ii. Identify conservation plan for effective monitoring.
- iii. There is urgent need to protect the existing indigenous fish stocks.
- iv. Enhance the fish quality and incorporate them into the value chain system of the society.

## REFERENCES

- America Public Health Association (APHA) (2005). Standard Methods for the Examination of Water and Waste Water. 21<sup>st</sup> edition. New York, 1193pp.
- Castillo-Rivera Manuel, (2013). Influence of Rainfall Pattern in the Seasonal Variation of Fish Abundance in a Tropical Estuary with Restricted Marine Communication. *Journal of Water Resources and Protection*. 5, 311-319.
- Dimowo, Benjamin Onozeyi (2013). Monthly spatial occurrence of phytoplankton and zooplankton in River Ogun, Abeokuta, Ogun State, Nigeria. *International Journal of Fisheries and Aquaculture*, 5(8): 193-203.
- Lawson, O.E and Modupe, O.O, (2010). Fish Diversity in Three Tributaries of River Ore, South- West, Nigeria. *World Journal of Fish and Marine Science*. 5(6):524-531, ISSN 2078-4589.
- Margalef, R. (1951). Diversidad de species en las comunidales naturales. *Publ. Boil. Apl.*, 9: 5-27
- Olasehinde, K.F, Abeke, A.A (2010). Plankton composition and abundance of Ikere gorge Dam reservoir, Iseyin south western Nigeria. *Journal of biodiversity and Environmental science* 2( 6 ):20-31.
- biology science* 6(5)936-940.
- Perebiche-Neves, G, Moacyr, S.J. Jorge, L.P, Erika, M.S., Andre, R.G. and Lineu D. (2012). Effect of a typical rainfall on lotic zooplankton: comparing downsstream of a reservoir and tributaries with free stretches. *Tropical Ecology*, 53 (2) 149-162.
- Shannon, C.E. and Weaver, W. (1949). The mathematical theory of communication. University of Illinois Press, Illinois, 125pp.
- Thirumala, S., Kiran, B.R. and Kantaraj, G.S. (2011). Fish diversity in relation to physico-chemical characteristics of Bhadra reservoir of Karnataka, India. *Advances in Applied Science Research*, 2 (5). 34-47.
- Varadharajan, D. and Soundarapandian, P, (2013). Zooplankton Abundance and Diversity from Pointcalimere to Manamelkudi, South East Coast of India. *Journal of Earth Science and Climate Change*, 4(5).
- Zarate-Hernandez, R., Manuel Castillo-Rivera, S. Orti-Burgos and J. Zavala-Hurtado (2012). Diel and Seasonal variability in the fish community structure of a Mud Bottom Estuary Habitat in the Gulf of Mexico. *Marine Ecology* 40 (2), 177-193.
- Zhou. G.J., Zhou, X.M., Bi, Y. H., Liang, Y.B., Hu, J.L., Yang, M., Mei, Y., Zhu, K.X., Zhang, L., and Hu, Z.Y. (2011). Phytoplankton variation and its relationship with the environment in Xiangxi Bay in spring after damming of the Three-Gorges, China. *Environmental Monitoring Assessment*, 176. 125-141.



# DETERMINATION OF PROXIMATE, MICRONUTRIENTS AND SENSORY QUALITIES OF NON-ALCOHOLIC BEVERAGE (KUNUN GYADA) PRODUCED FROM SORGHUM (*Sorghum bicolor*) groundnut (*Arachis hypogea*) BLENDS

Maxwell<sup>1\*</sup>, Y. M. O., B. A. Oyetunji<sup>2</sup>, O. B. Ocheme<sup>3</sup>, F. A. Femi<sup>4</sup>, J. Samaila<sup>5</sup> and C. M. Yakubu<sup>6</sup>

Department of Food Science & Technology, Federal University of Technology, Minna, Nigeria.

\*Corresponding Author's E-mail: [maxwellvom@gmail.com](mailto:maxwellvom@gmail.com) or [v.maxwell@futminna.edu.ng](mailto:v.maxwell@futminna.edu.ng) GSM: 08067284347

## ABSTRACT

Proximate, micronutrients and sensory qualities of non-alcoholic beverage (kunun-gyada) produced from sorghum-groundnut blends was examined. Kunun-gyada was produced by blending sorghum with groundnut at different proportions (0, 10, 20, 30 and 40%). Proximate, micronutrients and sensory qualities was determined using standard methods. Substitution of groundnut in sorghum beverage significantly increased the protein from (2.20–5.00%), ash (0.32–0.99%), Fat (0.40–1.30%) and carbohydrate (2.33–14.90%) compared to 100% sorghum. The sodium, potassium, calcium, magnesium and phosphorus contents of the blends increased significantly from 24.11–30.42mg/100g, 139.33–183.66mg/100g, 4.06–6.74mg/100g, 29.40–32.72mg/100g and 1.12–4.10mg/100g respectively. Also the beta-carotene and ascorbic acid content of the beverage increased significantly from 1.99–4.35mg/100g and 2.99–8.69mg. The sensory evaluation of the kunun-gyada samples indicated that higher mean scores were reported for samples containing groundnut than control without groundnut in most of the attribute tested. Sample C was most preferred, having highest mean score of 7.06, 7.46, 7.40, 7.13 and 7.73 in the attribute of taste, colour, flavour, mouth-feel and overall acceptability respectively. The study concluded that inclusion of groundnut in kunun-gyada resulted in an improved local beverage which could help in reducing/preventing malnutrition among consumers of kunun in Northern Nigeria.

**KEYWORDS:** blends, kunun-gyada, micronutrients, proximate composition, sensory qualities.

## INTRODUCTION

Beverages such as kunun-zaki, juice, coffee, tea, milk and soft drinks are liquid foods that serve as a source of both fluids and nutrients that refresh and nourish the body (Ihekoronye and Ngoddy, 1985; Maxwell *et al.*, 2018). Traditional beverages are of two types; alcoholic and non-alcoholic. Most beverages are made up of about 90% water, sugar, flavouring agents and sometimes preservatives.

A beverage such as kunun-zaki contains no alcohol and plays a very important role in the dietary pattern of people in developing countries like Nigeria (Abidoye *et al.*, 2017). Kunun-zaki is a cereal based non-alcoholic drink. It is a locally produced beverage and is made from millet, sorghum and maize grains and flavoured with such spices as ginger, black pepper and tamarind for improvement in its taste and aroma, which also serve as purgative and cure for flatulent conditions (Abidoye *et al.*, 2017). The basic ingredients of kunun-zaki are low in protein and some essential minerals and increasing prices of protein rich foods continue to force greater percentage of the populace, to eat food supplying less of the required dietary nutrient (Akintunde, 2005). This may have a negative effect on the nutritional status of the people who drink it, especially on the growth rate of children who are given kunun-zaki as a complementary drink. Due to inadequate supplies

of animal proteins, there has been a constant search for new protein sources, for use as both functional food ingredients and nutritional supplements that will support growth and sustain life (Adelekan *et al.*, 2013; Abidoye *et al.*, 2017).

Groundnut is the 6th most important oil seed crop and a good source of protein (Asibuo *et al.*, 2008). It contains 48-50% oil, 26-28% protein and 11-27% carbohydrate, minerals, vitamin and also rich in essential amino acids, which help in preventing malnutrition (Mukhtar, 2009; Pelto and Armar, 2011).

Kunun beverage are popularly consumed by majority in Northern Nigeria and it is produced majorly from cereals which are deficient in nourishing quality, especially essential amino acids, vitamins and minerals. Hence, the need for fortification with richer source of nutrient. The objective of the study was to determine the proximate, micronutrient and sensory qualities of non-alcoholic beverage (kunun-gyada) produce from sorghum-groundnut blends. The data from this study could actually be used for providing information on nutritional quality of the improved beverage blends which can contribute to recommend daily requirement of the populace. Also in designing nutrition intervention for school children in order to prevent malnutrition and providing policy in the State that will aid the achievement of the Sustainable

Development Goals 2 (SDG's). "End hunger, achieve food security and improved nutrition and promote sustainable agriculture".

## METHODOLOGY

### Proximate analysis

#### Determination of ash content

2ml of the sample was measured into crucibles in replicate, and the sample dried in oven, the sample was then cooled in desiccators and weighed. The weighed sample was incinerated in a muffle furnace at 550°C using Gallenkamp muffle furnace (Model OV160, Leicestershire, United Kingdom) until a light grey ash was observed and a constant weight obtained. The sample was cool in the desiccators to avoid absorption of moisture and to obtain ash content (AOAC, 2005).

$$\% \text{ Ash Content} = \frac{W_3 - W_1}{W_2 - W_1} \times 100$$

Where

W<sub>1</sub> = weight of empty crucible

W<sub>2</sub> = weight of crucible + food sample before ashing

W<sub>3</sub> = weight of the crucible + food sample after ashing

#### Determination of moisture content

This analysis was carried out to ascertain the amount of moisture in a given sample.

Materials; oven, weighing balance, spatula and petri dish.

Method: 10g of sample was weighed into a dry petri dish using a spatula. The weighed sample was loaded into the oven and dried at 105°C until a constant weight was achieved. The sample was removed, cooled and weighed.

Moisture content was calculated as.

$$\frac{A - B}{A} \times 100$$

A = initial weight of sample.

B = weight of oven dry sample.

#### Determination of fat content

2.5ml of the sample was measured and poured into a test tube in triplicate. 5ml of hydrochloric acid was added to each test tube, the test tube was then put in a beaker and water was added up to 200ml and allowed to stand for some time. The beaker was put on a cooker for 5 minutes and cooled for some minutes, the test tubes were put in the test tube rack after cooling. 5ml of ethanol was put into each test tube then 12.5ml of petroleum spirit. Empty petri dish was weighed, using syringe and needle the upper white layer of the mixture was drawn out from the test tube into the weighed petri dish, and the petri dish was in the oven to be dried, it was then cooled in a desiccator and weighed until a constant weight was obtained.

The percentage fat content was calculated as follows:

$$\text{Percentage of total fat content} = \frac{W_2 - W_1}{2.5\text{ml}} \times 100$$

Where W<sub>1</sub> = weight of empty petri dish

W<sub>2</sub> = weight of petri dish + dried sample

#### Determination of protein content

This test was carried out to know the percentage of crude protein in the sample. Materials used were; complete digestion block set, sulphuric acid (H<sub>2</sub>SO<sub>4</sub>), weighing balance, hydrochloric acid, boric acid, sodium hydroxide (NaOH), burette, pipette, pipette filler, conical flask, makhamp apparatus, indicator (Bromocresol green and Methyl red), selenium tablet,

#### Digestion stage:

Method: 0.5g of sample was taken and added into the digestion tube where also 20ml of concentrated sulphuric acid was added. One selenium tablet was added as catalyst. The content in the tube was heated at a temperature of 350°C for 6 hours until a clear digest was achieved that is a clear solution. This solution was poured into a standard flask and made up to 100ml.

#### Distillation stage:

10ml of 2% boric acid was taken into a 100ml conical flask and added with three drops of mixed indicator (Bromocresol green and Methyl red) and the colour changes to pink which was then placed under the collecting spot. 10ml of the digested sample was pipetted into the open chamber of the makhamp apparatus then followed by 10ml of 40% NaOH. The mixture was forced to boil by the steam produced by the boiling water in the flat bottom flask. As the mixtures boil, a gas (ammonia) was evolved and condensed by the condenser of the apparatus which was collected in the form of liquid into the boric acid. As the ammonia was collected in the boric acid, the solution turned blue.

#### Titration stage:

The distillate collected was titrated using 0.1M HCL until an end point is reached by the colour of the distillate changing to pink colour which is the initial colour of the boric acid and the mixed indicator.

$$\text{Crude protein is calculated as} \\ \frac{TV \times 0.014 \times MA \times df}{wt \text{ of } S} \times 100$$

TV = titre value.

0.014 = nitrogen standard.

MA = molarity of acid.

Wt of S = weight of sample.

#### Determination of carbohydrate content



Determination of carbohydrate content of the kunun-gyada beverage was carried out by simple mathematical calculation method. It is usually obtained by subtracting all the sum of percentages of all the nutrients that are already determined from 100. The remaining value obtained is the carbohydrate content of the sample. % carbohydrate = 100 – (% moisture+% ash+% protein+% fat)

#### Determination of vitamin and mineral

##### Determination of ascorbic acid

The ascorbic acid of the sample was determined using the method describe by Onwuka (2005). 5ml of stock was transferred into a conical flask of 100ml and 4% oxalic acid of 10ml was added and titrate with indophenols (VI ml) until a pink coloration was obtained which indicate the end point. The quantity of indophenols used was equal to the quantity of stock used. 5ml of sample was added in 4% oxalic acid and make up to 100ml and centrifuge. To the supernatant (clear decanted liquid) 5ml, oxalic acid 10ml was added and titrate with the indophenols blue (V2 ml). The ascorbic acid content will be calculate as shown below

$$\text{Ascorbic acid} = \frac{0.5}{4.5} \times \frac{\text{titre value}}{5} \times \frac{100}{5} \times 100 \text{mg}/100\text{g}$$

##### Determination of beta-carotene

The beta-carotene of the sample was determined using the method outline by AOAC (2005). Beta-carotene analysis was carried out using the acetone extraction method, 20ml of sample was measured into a conical flask, 40ml of acetone was measured into the conical flask containing the sample and was allowed to stand for 15 minutes for separation to occur. 5ml syringe was used to draw liquid out of the conical flask, into another conical flask and was allowed to stand for 5 minutes. The extract was poured in a cuvet and absorbance was read in spectrophotometer at wavelength of 663nm, 644nm, 452nm. The beta-carotene content will be calculate as shown below

$$C_{a+b} = (6.4 Q_{663} + 18.8 D_{644})$$

$$\text{Carotene} = (4.75 D_{452} - 0.226 C_{a+b}) \text{ mg}/100\text{g}$$

##### Determination of minerals

The method of AOAC (2005) was used for mineral determination. 1ml of sample was weighed into 100ml and 20ml of acid mixture was added (Nitric and perchloric acid 1:1) and heat at 200°C until a clear solution is achieved. The sample was allowed to cool and transfer into a standard conical flask and made up to 100mls.

##### Determination of sensory properties

Sensory evaluation of kunun beverage were determined using (Ihekoronye and Ngoddy, 1985) method for consumer acceptability and using 30 panelists who were randomly select. The panelist accessed the samples base on taste, flavour, colour, mouth-feel and overall acceptability using a 9-point hedonic scale where 1 represent extremely dislike and 9 extremely like.

#### Statistical analysis

Data generated were subjected to statistical analysis using Computer package (SPSS version 20) was used to analysis all data. Analysis of variance (ANOVA) was carried out while means of significant figure were separated using Duncan Multiple range test.

## RESULTS AND DISCUSSION

### Proximate Analysis

The proximate composition of fortified kunun-gyada beverage is presented in Table 1. The result showed that the moisture content of the beverage samples ranged from 79.81 - 94.06 %. Sample E (control) had significantly higher moisture content than other samples; sample B and sample C were not significantly different from each other but shows significant difference from other samples. The results obtained for moisture content were higher than those reported in previous studies (Amusa and Ashaya, 2009; Umaru *et al.*, 2014).

The protein value of the samples ranged from 2.20 - 5.00 %. Sample D was significantly difference across all the samples analyzed with sample D having the highest value of 5.00% while sample E appears to have a lower value of 2.20%. Kunun-gyada fortified with groundnut recorded higher protein contents than the control containing no groundnut. The protein content of some of the samples in this study were similar to each other than those reported in previous studies (Olaoye *et al.*, 2017).

The ash content of the beverage ranged from 0.32 - 0.99 %. Sample B and C were not significant different from each other while sample E shows a lowest significant difference from other samples. The result of the ash content of the beverage samples was lower when compared to previous studies (Olaoye *et al.*, 2017). Makinde and Oyeleke (2012) reported increase in the ash contents of kunun zaki enriched with extract of sesame seeds over the control sample without the extract. However, Ogbonna *et al.*, (2013) and Adelekan *et al.*, (2013) obtained ash content of higher values in their finding on kunun-zaki than those recorded in this study. The difference could be attributed to the different types of cereals used in the production of the beverage in the different studies. Different cereal types have abilities to contribute to



the ash content of kunun as a result of the differences in their ash compositions.

The percentage of fat obtained in this work is lower but quite higher than that reported by (Akoma *et al.*, 2006). The fat content shows some varying degree of variation with sample D having a higher value of 1.30, sample A, B and C appear to have no significant difference to each other but significantly different to sample D.

The carbohydrate content of all the sample shows a significant different across all the sample with sample D having the highest value followed by sample C while sample E appearing to have the lowest value of 2.33%. The results obtained for carbohydrate content in this study were lower when compared with previous studies carried out by (Amusa and Ashaye 2009). This may be as a result of the experiment which shows that kunun processed from un-sieved flour retained most of the nutrients according to (Abidoye *et al.*, 2017).

#### **Mineral Contents Analysis**

The mineral results of fortified kunun-gyada beverage is presented in Table 2. The results ranged thus: Na (24.11- 30.42), K (1.39-1.83), Ca (4.06-6.74), Mg (29.40-32.72) and P (1.12-4.10). From the table, it shows that there was a significant difference at  $p \leq 0.05$  for sodium in all the sample analyzed with sample C having the highest value of 30.42mg/100g. This variation is also observed for potassium across all the samples although, sample B and D shows no significant difference with sample C and E following a similar trend. There is also an observable difference in the calcium content of the samples analyze although, no major difference between sample C and D so also sample A and E respectively. No significant difference is observed in magnesium between sample A and B and also sample C and D while sample E was significantly different to all the sample although, having the lowest value of 29.40mg/100g. The concentration of phosphorus in all the samples shows a significant difference although, sample B and C were not significant to each other at  $p \leq 0.05$  level of significance while sample E appear to have the lowest value of 1.12mg/100g. The results of blended kunun-gyada had higher values compared to the unblended sample. The values of Na, K, Ca, and Mg were in close agreement with those values reported for fortified kunun beverage (Abulude *et al.*, 2006). It was also in line with those values reported for Apricot purees (Voi *et al.*, 1995) and fortified sobo drinks (Abulude and Adebusey, 2005).

#### **Vitamin Contents Analysis**

The vitamin results of fortified kunun-gyada beverage is presented in Table 3. The beta-carotene content of the sample ranged from 1.99-4.35mg/100g. Sample C and D had a significant higher  $p < 0.05$  beta-carotene values than other samples while sample E (control) had the lowest value. The ascorbic acid of the beverage ranged from 3.00-8.69. Sample D had a significant higher value of ascorbic acid compared to other samples. The increase recorded in the vitamins contents especially beta-carotene and vitamin C in the samples could be due to incorporation groundnut blends.

#### **Sensory Analysis**

The sensory qualities of fortified kunun-gyada beverage is presented in Table 4. Sample C recorded highest scores of 7.06, 7.46, 7.40, 7.13 and 7.73 in the attribute of taste, colour, flavour, mouth-feel and overall acceptability respectively. Significantly differences ( $p < 0.05$ ) were recorded between the sample without the addition of groundnut. A similar result was reported in previous studies of kunun-zaki samples by Olaoye *et al.*, (2017) indicated that the sample containing tigernut milk extract recorded highest scores in the respective attributes of appearance, flavor, taste and overall acceptability.

#### **CONCLUSION AND RECOMMENDATIONS**

The fortified kunun-gyada produced from blends of sorghum-groundnut yielded better result in respect of their protein content and micronutrient values. The improved blends also recorded greater acceptability rate in relation to the commonly consumed kunun made from sorghum. This improved blend of kunun will bridge the gap in macro and micro-nutrient deficiency. The use of other cereals and legumes in local beverage drink production will bring about diet diversification. From the results obtained in this study, we concluded that incorporation of groundnut into kunun will supply some degree of fortification of the product and also improved sensory qualities. Based on the results of the research work, it is recommended that inclusion of groundnut should be encouraged among producers of the kunun beverage drink as a result of the derivable nutritional benefits that consumers can gain. Also further studies should be carried out to determine the storage stability, microbial and safety of the product.

#### **ACKNOWLEDGMENTS**

Authors appreciate Mr. Audu Yohanna of the Department of Animal Production, Federal University of Technology, Minna for providing enabling environment to carry out some of the analysis for this study.

Table 1: Proximate composition of Kunun-gyada beverage

Samples	Moisture content	Crude protein	Ash content	Fat content	Carbohydrate
A	89.72±0.10 <sup>b</sup>	3.40±0.05 <sup>d</sup>	0.70±0.10 <sup>b</sup>	0.60±0.20 <sup>c</sup>	5.21±0.01 <sup>d</sup>
B	79.87±0.05 <sup>d</sup>	4.26±0.15 <sup>c</sup>	0.83±0.10 <sup>ab</sup>	0.65±0.23 <sup>c</sup>	12.48±0.10 <sup>c</sup>
C	79.81±0.10 <sup>d</sup>	4.66±0.15 <sup>b</sup>	0.83±0.18 <sup>ab</sup>	0.96±0.10 <sup>bc</sup>	13.76±0.00 <sup>b</sup>
D	80.73±0.15 <sup>c</sup>	5.00±0.25 <sup>a</sup>	0.99±0.05 <sup>a</sup>	1.30±0.10 <sup>a</sup>	14.90±0.60 <sup>a</sup>
E	94.06±0.20 <sup>a</sup>	2.20±0.25 <sup>e</sup>	0.32±0.25 <sup>c</sup>	0.40±0.00 <sup>c</sup>	2.33±0.04 <sup>e</sup>

Values are mean ± standard deviation of triplicate determination. Samples with different superscript vary significantly ( $p \leq 0.05$ ) while those with the same letters are not significantly different.

Keys

- A 90 sorghum + 10 groundnut
- B 80 sorghum + 20 groundnut
- C 70 sorghum + 30 groundnut
- D 60 sorghum + 40 groundnut
- E 100 sorghum (control)

Table 2: Mineral composition of Kunun-gyada beverage

Sample	Sodium	Potassium	Calcium	Magnesium	Phosphorus
A	27.95±0.27 <sup>c</sup>	183.66±2.51 <sup>a</sup>	4.15±0.20 <sup>c</sup>	31.05±0.13 <sup>b</sup>	2.81±0.00 <sup>c</sup>
B	28.65±0.46 <sup>b</sup>	141.66±1.52 <sup>c</sup>	5.61±0.01 <sup>b</sup>	31.00±0.00 <sup>b</sup>	3.44±0.01 <sup>b</sup>
C	30.42±0.00 <sup>a</sup>	151.33±2.30 <sup>b</sup>	6.72±0.01 <sup>a</sup>	32.72±0.43 <sup>a</sup>	3.24±0.26 <sup>b</sup>
D	27.25±0.04 <sup>d</sup>	153.66±3.21 <sup>b</sup>	6.74±0.08 <sup>a</sup>	32.64±0.01 <sup>a</sup>	4.10±0.06 <sup>a</sup>
E	24.11±0.00 <sup>e</sup>	139.33±3.05 <sup>c</sup>	4.06±0.02 <sup>c</sup>	29.40±0.51 <sup>c</sup>	1.12±0.01 <sup>d</sup>

Values are mean ± standard deviation of triplicate determination. Samples with different superscript vary significantly ( $p \leq 0.05$ ) while those with the same letters are not significantly different.

Keys

- A 90 sorghum + 10 groundnut
- B 80 sorghum + 20 groundnut
- C 70 sorghum + 30 groundnut
- D 60 sorghum + 40 groundnut
- E 100 sorghum (control)

Table 3: Vitamin composition of Kunun-gyada beverage

Sample	Beta-carotene mg/100g	Ascorbic acid mg/100g
A	2.25±0.05 <sup>c</sup>	4.39±0.05 <sup>d</sup>
B	3.00±0.10 <sup>b</sup>	7.58±0.20 <sup>c</sup>
C	4.35±0.05 <sup>a</sup>	8.19±0.05 <sup>b</sup>
D	4.35±0.15 <sup>a</sup>	8.69±0.20 <sup>a</sup>
E	1.99±0.10 <sup>d</sup>	3.00±0.02 <sup>e</sup>

Values are mean ± standard deviation of triplicate determination. Samples with different superscript vary significantly ( $p \leq 0.05$ ) while those with the same letters are not significantly different.

Keys

- A 90 sorghum + 10 groundnut
- B 80 sorghum + 20 groundnut
- C 70 sorghum + 30 groundnut
- D 60 sorghum + 40 groundnut
- E 100 sorghum (control)

Table 4. Sensory analysis of Kunun-gyada beverage

Sample	Taste	Colour	Flavour	Mouth-feel	Overall Acceptability
A	6.13±1.57 <sup>b</sup>	6.63±1.52 <sup>a</sup>	6.23±1.77 <sup>bc</sup>	6.00±1.52 <sup>b</sup>	6.80±1.24 <sup>b</sup>
B	7.53±1.43 <sup>a</sup>	7.30±1.48 <sup>a</sup>	7.06±1.46 <sup>ab</sup>	7.20±1.49 <sup>a</sup>	7.46±1.27 <sup>ab</sup>
C	7.06±1.28 <sup>a</sup>	7.46±1.22 <sup>a</sup>	7.04±1.22 <sup>a</sup>	7.13±1.22 <sup>a</sup>	7.73±0.98 <sup>a</sup>
D	6.00±1.55 <sup>b</sup>	6.83±1.70 <sup>a</sup>	6.03±1.67 <sup>c</sup>	5.70±1.72 <sup>b</sup>	6.00±1.33 <sup>c</sup>
E	4.56±2.02 <sup>c</sup>	5.56±2.07 <sup>b</sup>	5.10±2.12 <sup>d</sup>	4.53±2.28 <sup>c</sup>	4.90±1.90 <sup>d</sup>

Values are mean ± standard deviation of triplicate determination. Samples with different superscript vary significantly ( $p \leq 0.05$ ) while those with the same letters are not significantly different.

Keys

- A 90 sorghum + 10 groundnut  
 B 80 sorghum + 20 groundnut  
 C 70 sorghum +30 groundnut  
 D 60 sorghum +40 groundnut  
 E 100 sorghum (control)

## REFERENCES

- Abidoye O. A., Taiwo K. and Adeniran H. (2017). Fortification of kununzaki drink with cocoa powder. *African Journal of Food Science* Vol. 11(4) pp. 112-123.
- Adelekan, A.O., Alamu, A.E., Arisa, N.U., Adebayo, Y.O., and Dosa, A.S. (2013). Nutritional, Microbiological and Sensory Characteristics of Malted Soy-Kunu Zaki: An Improved Traditional Beverage. *Advances in Microbiology*. 3, 389-397.
- Abulude, F. O., Adebuseye, A. J., (2005). Chemical composition and acceptability of fortified sobo drinks. *Pal. J. Indeed. Science. Res.* 5(1): 155-162.
- Abulude, F.O., Ogunkoya, M.O., and Oni V.A. (2006). Mineral composition, shelf life and sensory attributes of fortified kunuzaki beverage. *Acta Sci. Pol., Technol. Aliment* 5(1): 155-162.
- Akintunde T.Y. (2005). Nutritional and sensory qualities of soymilk-kunnu blends. *African J. of Food Agric., Nutrition and Development*. 5:2.
- Akoma, O., Jiya, E., Mishilia, E. (2006) Influence of malting on the nutritional characteristic of kunu-zaki. *African Journal of Biotechnology* 5(10): 996-1000.
- Amusa, N., Ashaye, O., (2009). Effect of processing on nutritional, microbiological and sensory properties of kunu-zaki (a sorghum based non-alcoholic beverage) widely consumed in Nigeria. *Pakistan Journal of Nutrition* 8(3): 288-292.
- AOAC. Official Methods of Analysis International. 18th Edition. Association of Official Analytical Chemist. USA. 2005.
- Asibuo, J.Y., Akromah, R., Safo-Kantanka, O.O., sei, AduDapaah, Hanskofi, O.S., and Agyeman, A. (2008). Chemical Composition of Groundnut, Arachis hypogaea (L) landraces. *African Journal of Biotechnology*. Vol, 7(13):pp: 2203-2208.
- Ogbonna, A. C., Abuajah, C. I., Akpan, M. F. and Udofia, U. S. (2013). A comparative study of the nutritional values of palm wine and kunnu zaki. *AFST* 14, 39-43.
- Onwuka, G.I. (2005). Food Analysis and Instrumentation: Theory and Practice. Naphthali prints, Lagos, Nigeria. PP. 140-146.
- Pelto Gretel, H. and Margaret Armar -Klemesu (2011). Balancing Nurturance, cost and time: Complementary feeding in Accra, Ghana. *Maternal and Child Nutrition* /Volume 7, Issues 3.
- Ihekoronye, A.I. and P.O. Ngoddy, 1985. Integrated Food Science and Technology for the Tropics. Macmillian Publishers, London, uk, PP: 75-77.
- Makinde, F. and Oyeleke, O. (2012). Effect of sesame seed addition on the chemical and



sensory qualities of sorghum based kunun-zaki drink *African Journal of Food Science and Technology*. 3(9): 204-212.

Maxwell Y.M.O., Alabi M.O. and Edohe A.O. (2018). Effect of Spices on Anti-nutritional Properties of Tiger-nut

Beverage (*kunun aya*). *Proceedings of the 42nd Annual Conference and General Meeting of the Nigerian Institute of Food Science and Technology, Abeokuta, Nigeria. October 15-18th, Pp. 24-25.* Shittu T.A. Adeola A.A., Omohimic C., Bolarinwa I.F. Badejo A.A. and Abu J.O. (Editors).

Mukhtar, F.B. (2009). Effect of storage temperature on post-harvest deterioration of banana and plantain (*Musa sp.*). *Int. J. Phys. Applied Sci.*, 3: 28-38.

Voi, A. L., Impembo, M., Fasanaro, G. and Gastaldo, D. (1995). Chemical characterization of apricot puree. *J. Food Comp. Anal* 8, 78-85.

Umaru, G., Tukur, I. and Adamu, N. (2014). Microflora of kunu-zaki and zobo drinks in relation to public health in Jalingo metropolis, North-Eastern Nigeria. *International Journal of Food Research 1*: 16-21.

## COMPARATIVE ANALYSIS OF NIGERIA AND INDIA ESSENTIAL MACRO-ECONOMIC INDICES

Job Nmadu<sup>1</sup>, Kpotun Baba<sup>1</sup>, Taye Amos<sup>2</sup>, Ezekiel Yisa<sup>1</sup>, Usman Mohammed<sup>1</sup>, Halima Sallawu<sup>1</sup>

<sup>1</sup>Department of Agricultural Economics and Farm Management,  
Federal University of Technology, Gidan Kwano Campus, Minna, 920102, Nigeria

<sup>2</sup>Department of Agricultural and Resource Economics,  
Federal University of Technology, Main Campus, Akure, 340252, Nigeria

\*Corresponding Author's email: job.nmadu@gmail.com

### ABSTRACT

*Bearing in mind the long standing relations between Nigeria and India, a comparative analysis of their 2008 SAM was undertaken in order to assess the relative strength of each country. To do this, the forward and backward linkages of the economies obtained from the technical coefficients were compared. In spite of the fact that per capita GDP of Nigeria is higher than India, it was found that Nigeria's GDP is dominated by import while that of India was dominated by private consumption expenditure. Nigeria's economy is still import dependent while the export sector is dominated by primary products like yams and oil and gas, making Nigeria vulnerable to external shocks. There are also wide disparities between the domestic demand of goods between Nigeria and India. Nigeria must reduce the importation of capital goods and increase investment spending on the public sector services for up to 45% of that of India in order to be at the present welfare level of India..*

**KEYWORDS:** GDP, Forward integration, Backward Integration, GAMS, RStudio

### INTRODUCTION

Social Accounting Matrix (SAM) originated with the work of Meade and Stone (1940), when a national account of the UK was first composed. Subsequently, a SAM of the UK was first composed by Stone (1962). It is thought that the SAM of developing countries was first composed around 1970 (Stone, 1977; Cicowiez & Sánchez, 2012).

A SAM is a comprehensive, consistent and complete datasytem that captures the various interdependence and linkages that exists within and between economic systems, typically of a country. According to Burfisher (2011), a SAM is a database that gives a logical framework of the visual display of all the transactions and circular flow (Fig. 1) of income and spending of an economy. The aggregation of the data in a SAM describes the macroeconomic behaviour of a country or region (Cicowiez & Sánchez, 2012). In addition, the linkages among agents/industries tend to show their demand for primary factor and intermediate inputs as well as the level of competition for the factors of production, notably land, labour and capital.

SAM has some unique features including being a square matrix and each agent (commodity, industry, land, labour capital, taxes, savings, investment, households, enterprises, government, rest of world) having a column and a row. The grand total of all the columns or rows is the country's GDP. The column is a record of the spending while the row gives the income of GDP. In addition, each cell of SAM simultaneously depicts expenditure and income by an agent. The column total is the total expenditure by

each agent while the row total is the total income accruing to each agent implying that supply equals demand of the economy. However, SAM is neither a time series data nor does it explain the behavioural and technical relationships that generated its values (Burfisher, 2011; Cicowiez & Sánchez, 2012; Breisinger, Thomas & Thurlow, 2009).

The activity/industry column of SAM can be used to divide the economy into intermediate inputs and value-added to the economy. The value-added is further divided into factor payments, factor use tax, sales taxes and production tax. In addition, the activity column can be used to determine the input-output coefficients (I/O) of the economy, by dividing each cell by its column total. The I/O describes the intermediate input intensity or factor intensity. The economy is intermediate or factor intensive in the activity with the highest I/O. The I/O is then used to determine the backward linkage index (i.e. the sum of the coefficients of all intermediate goods used in the sector). In addition, from SAM, forward linkage index (the share of an industry's output that is used as intermediate inputs by other industries) of the economy is calculated (Burfisher, 2011).

The current independently prepared SAM for Nigeria is the 2006 SAM by Nwafor, Diao & Alpuerto (2010) which is a 61 sector/activities with the column and row beginning with activities account, followed by commodities account and thereafter accounts for the economic agent in the Nigerian economy. The SAM has 12 manufacturing sectors (such as beef, textiles, and wood products); 2 mining sectors (including crude petroleum and natural gas); and 13 service

sectors (such as building and construction, electricity and water, and hotels and restaurants). The SAM was built from various data sources, including but not limited to publications of the National Bureau of Statistics (NBS), the Central Bank of Nigeria (CBN), and the Federal Ministry of Agriculture and Water Resources (FMAWR). In addition, the earlier Nigerian SAM developed by UNDP in 1995 was also used and was balanced using the cross entropy estimation method (Keyzer, Merbis, van Veen, & van Wesenbeeck, 1996). On the other hand, the current Indian SAM is the 2012 SAM prepared by Pal, Pohit & Roy (2012). The compositions and details of the SAM which are aptly described by Pal, et al. (2015) have 85 sectors i.e. agriculture (19), livestock products (1), forestry, mining (9), manufacturing (32), construction, electricity (3), biomass, water supply, transport (5), other services (12). Unlike Nigeria, India has a more consistent history of SAM development. In all, India has developed nine SAMs starting in 1981.

Nigeria-India relations have existed over time, both being members of the Commonwealth and have established diplomatic and bilateral relations. India established a diplomatic mission in Nigeria since 1958, even before Nigeria gained independence from Britain in 1960. Nigeria is the largest trading and largest market in Africa for Indian exports. Whereas India exports to Nigeria as at 2013 was valued about USD2.738B and on the increase, Nigeria's export to India was USD1.3826B and on the decrease (Anonymous, 2017). Currently, Nigeria is just coming out from some contraction of the economy which was triggered by the change of administration in 2015. As at 2016, the GDP of Nigeria was USD405,952M while that of India was USD2,256,397M showing that India's GDP is far higher than Nigeria, even historically (Fig. 2), but per capita GDP of Nigeria (USD2,183) was higher than that of India (USD1,704) (Anonymous, 2017a).

From the foregoing, it can be observed that, although the two economies are buoyant and in spite of the long standing relations, the balance of trade is clearly in favour of India. In view of this, there is need to understand, sector by sector, how Nigeria and India compares economically and to investigate possible reasons for the divergence, if any. It is also important to seek for lessons that Nigeria can learn from India in order to increase the export of Nigerian goods to India and possibly reduce imports. The natural questions to ask therefore are to what extent does Nigeria's GDP as well as forward and backward linkages in the economy compare to that of India. The objectives of this study, therefore, are to estimate the GDP, forward linkage and backward linkage of both countries and compare them with a view to

identifying the weak points of Nigeria which can be used to formulate policies that will engender increasing and sustained GDP using a common yardstick. It is hoped that the result of this study will be utilised by policy makers, researchers and the media to foster economic welfare of Nigerians.

## METHODOLOGY

The data for this research is the 2008 SAM of Nigeria and India obtained from McDonald & Thierfelder (2004) and Badri & Walmsley (2008). The SAM is aggregated into 10 commodities/industries and five factors of production. The aggregated commodities/industries are Agriculture (AGR), Mining & Extraction (MXT), Processed Food (PFO), Labour-Intensive Manufactures (LIM), Capital-Intensive Manufactures (CIM), Utilities and Construction (UCO), Transportation & Communication (TCM), Private Financial & Other Services (PFT), Public Services (PSE) and Dwelling (DWE). The aggregated factors namely Land, unskilled labour, skilled labour, capital and natural resources are not a major focus of this paper.

In addition to the SAM, a structured table for analysing the SAM and obtaining various GDP metrics (domestic and export demand, import and export shares, commodity/industry shares in the import and export trade) was obtained from GTAP (2017). After the GDP was estimated with the structured table, then the individual cells in the 10x5 SAM were converted to input-output (technical) coefficients. From the input-output coefficients, the forward and backward linkage indices for the various sectors were determined (Burfisher, 2011). The intermediate demand of each sector of the economy was estimated using modified GAMS (GAMS, 2017) codes developed by Bayer (2000). The results were presented using bar charts. All the charts and graphs were rendered using RStudio and some r-packages (Allaire, et. al., 2017; R Core Team, 2017; Wickham, 2009; Neuwirth, 2014).

## RESULTS AND DISCUSSION

The results of the various comparisons are presented in Fig. [3] - [13]. As can be observed in Fig [3] - [6], in the case of Nigeria and India, capital-intensive manufactures had the highest pull on the economies while public services exerted the least pull on Nigerian economy and dwelling exerted the least pull on the Indian economy (Fig.4). On the other hand, capital intensive manufacture (Fig. 3) still gave the greatest push to the Indian economy while in Nigeria; it is the utilities and construction that gave the greatest push to the economy. Expectedly, the largest difference between the linkage patterns of Nigeria



and India are dwelling for forward linkage and processed foods for backward linkage (Fig 5). In addition, Indian economy is far ahead of Nigerian public services and mining & extraction (Fig. 6). So if Nigeria were to focus on sectors that will bring immediate push to the economy, it should be public services, like roads, schools, power, health facilities which will definitely increase private consumption and hence stabilise Nigerian economy against external shocks.

The result in Fig.7 show that mining & extraction rules Nigeria's economy while agriculture and transport & communication rules India's economy. A similar trend is observed in Fig.8 where the major contributor to India's GDP is private consumption and the main contributor to Nigeria's GDP is exports. The implication of this will be discussed shortly.

Nigeria's domestic demand is agriculture and capital-intensive manufactures whereas India's domestic demand is agriculture, utilities, transportation & communication, all of which India has the internal capacity and technology (Fig. 9). In the agriculture sector of Nigeria, substantial amount of agricultural produce are imported (rice, wheat, sugar). Furthermore, Fig.10 shows that Nigeria is importing expensive finished goods whereas India is importing cheap raw materials which are then processed and exported again. Here investment in technology improvement through research and development activities is what is needed to catch up with India.

Nigeria's economy is almost entirely dependent on mining & extraction sector i.e. oil and gas (Fig. 11). And as can be observed further, the oil and gas are exported raw, making Nigeria's foreign exchange sector dependent on it. This phenomenon has not changed much even with the current drive towards diversification of the economy. What many Nigerians understand as diversification is primary agricultural production and exporting raw agricultural produce which will leave Nigeria in the hands of unstable foreign exchange earnings. What Nigeria can learn from India here is to export only finished goods and grow the technological base of the country through research and development. In Fig.12 it is observed that Nigeria is far more import-dependent than India and most goods imported to Nigeria are in the finished category (consumption expenditure), not raw materials (investment expenditure) that could be used to enhanced the economy.

The predominant sectors in Nigeria and India's export sector are common i.e. mining & extraction, labour-intensive manufactures and private financial and other services, although the mining (notably oil and gas) sector still rules Nigeria's export economy (Fig 13). This is a confirmation that most of Nigeria's exports are raw materials and not finished goods,

which do not help the internal strength of the economy against adverse shocks, especially from outside the economy.

The intermediate demand for goods and services by Nigeria and India follow similar patterns with the other measures (Fig. 14). However, Nigeria's demand is only higher than that of India in the labour-intensive manufacturing (LIM) and processed foods (PFO) sectors of the economy. This has further confirmed the low level of industrialisation in the Nigerian economy and the dependence on imports, particularly in the processed foods sector. Therefore, Nigeria needs to target its capital intensive manufactures through unprecedented increased funding of research and development activities.

The technical coefficients in Fig. 15 indicated that Nigeria's economy is heavily dependent on labour-intensive manufactures, processed foods as well as transportation and communication while India is Agriculture, capital intensive manufactures as well as utilities and construction. This is a further indicator that Nigeria needs to massively fund technology so that the benefit of scale economies can be derived with lower cost of production.

## CONCLUSION AND RECOMMENDATIONS

The unique features of SAM makes it a strong candidate for comparing the economic performance of various countries, sector by sector, as was done in this paper for Nigeria and India. The goal of the comparison was to identify areas where Nigeria can learn from India how to improve performance and which sectors will present a greater pull or push towards sustainable developments and achievement of the 2030 agenda. The comparison was achieved by computing the forward and backward linkage indices through the technical coefficients of the various sectors of the economies.

The major findings indicate that in the case of Nigeria and India, capital-intensive manufactures had the highest pull on the economies while public services exerted the least pull on Nigerian economy and dwelling exerted the least pull on the Indian economy. The largest difference between the linkage patterns of Nigeria and India are dwelling for forward linkage and processed foods for backward linkage. In addition, Nigeria's domestic demand is agriculture and capital-intensive manufactures whereas India's domestic demand is agriculture, utilities, transportation & communication, all of which India has the internal capacity and technology. It is recommended that Nigeria should focus on increased funding of research and development as well as public services, like roads, schools, power, health facilities which will definitely increase private

consumption and hence stabilise Nigerian economy against external shocks.



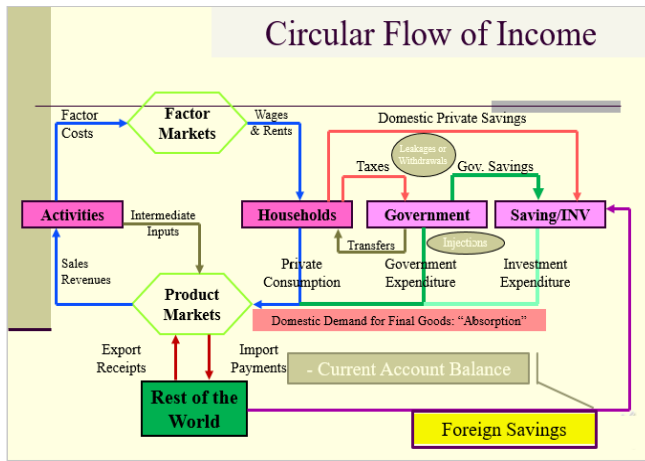


Figure 1 Circular flow diagram of a typical economy  
 Source: Personal communication Rob Davies and Dirk van Seventer (2018)

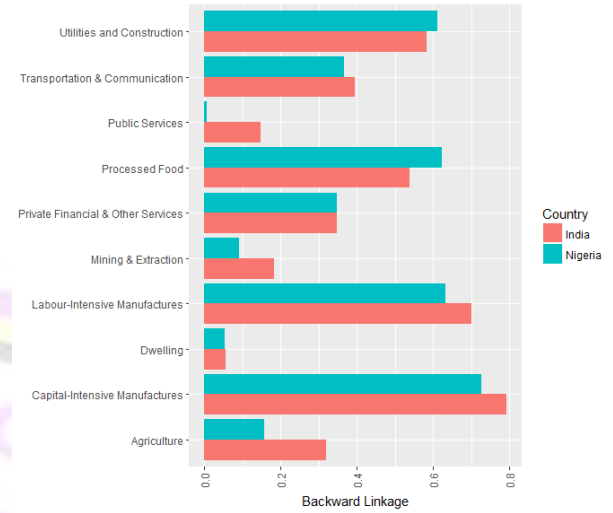


Figure 4 Backward linkage in the Economy of Nigeria and India

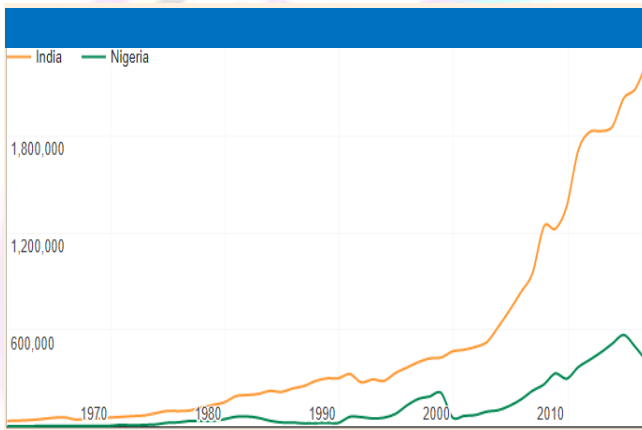


Figure 2 Comparison of GDP at market prices of Nigeria vs India  
 Source: Anonymous (2017a)

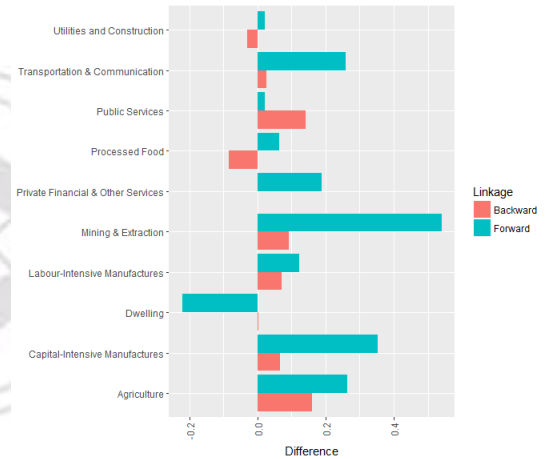


Figure 5 Difference in the linkage pattern in the Economy of Nigeria and India

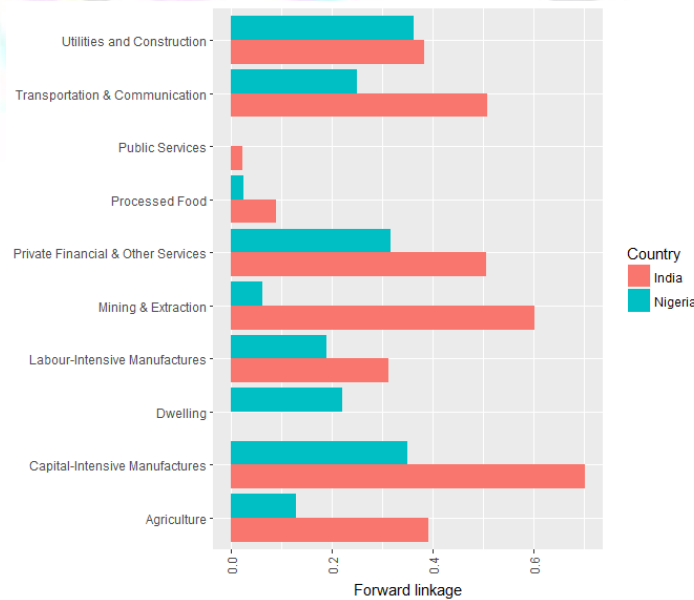
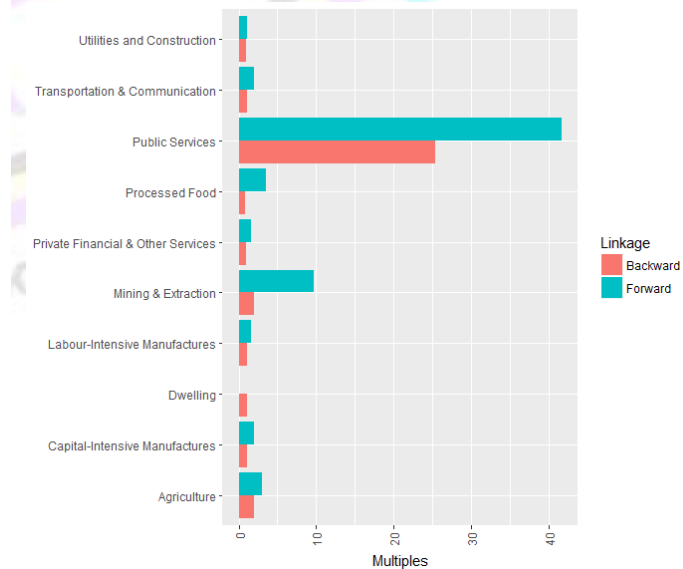


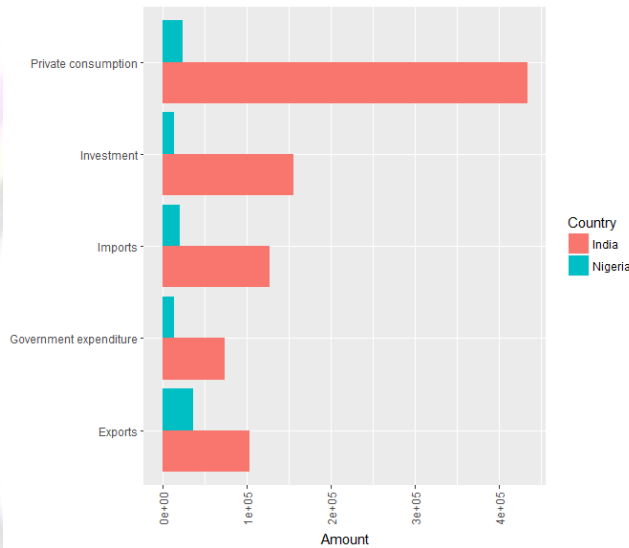
Figure 3 Forward linkage in the Economy of Nigeria and India





composition from expenditure side of Nigerian and Indian Economy

Figure 6



Multiples of Indian linkage pattern to the Nigerian pattern

Figure 8 GDP commodity share in the domestic demand of Nigerian and Indian Economy

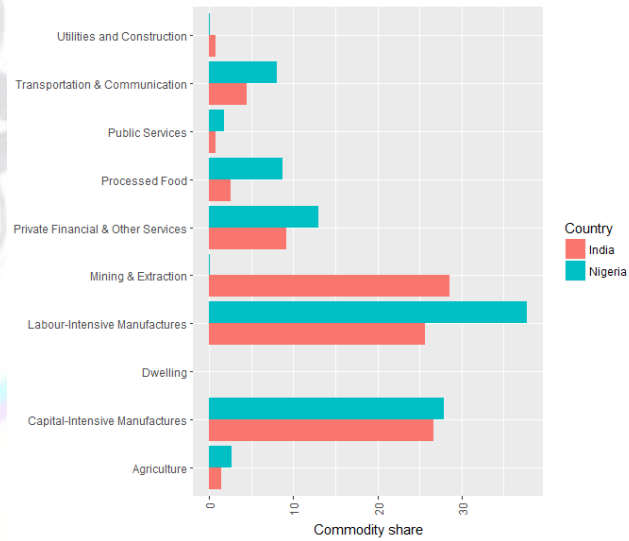


Figure 7 GDP

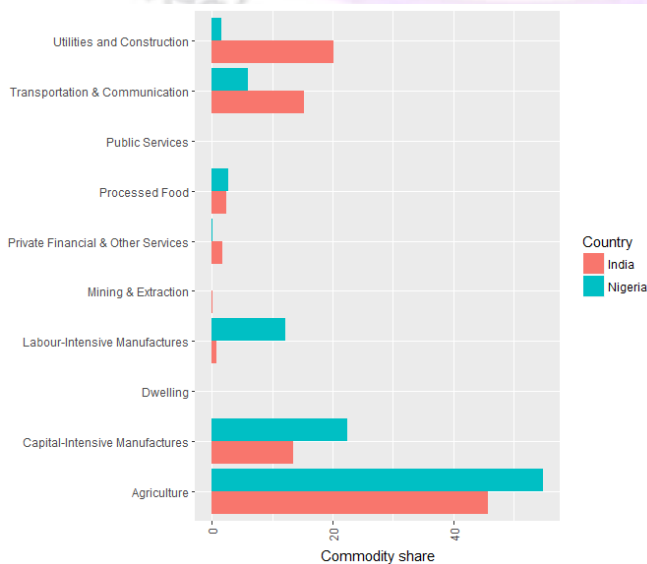


Figure 9 Commodity share in the import trade of Nigerian and Indian Economy

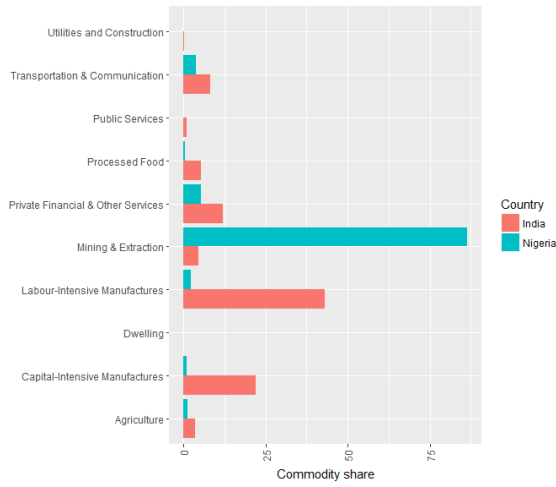


Figure 10 Commodity share in the export trade of Nigerian and Indian Economy

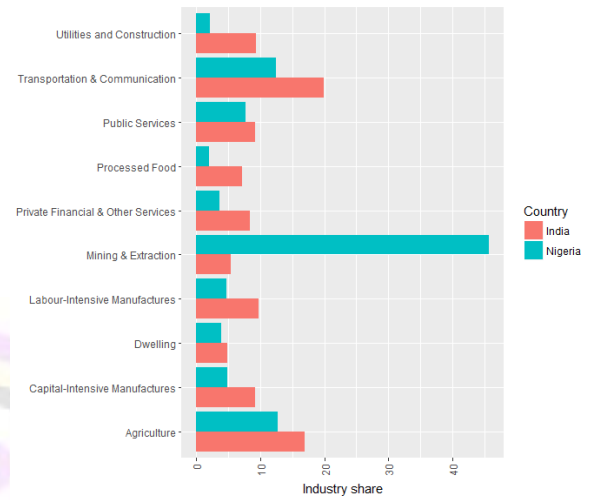


Figure 13 Industry share of Nigerian and Indian Economy

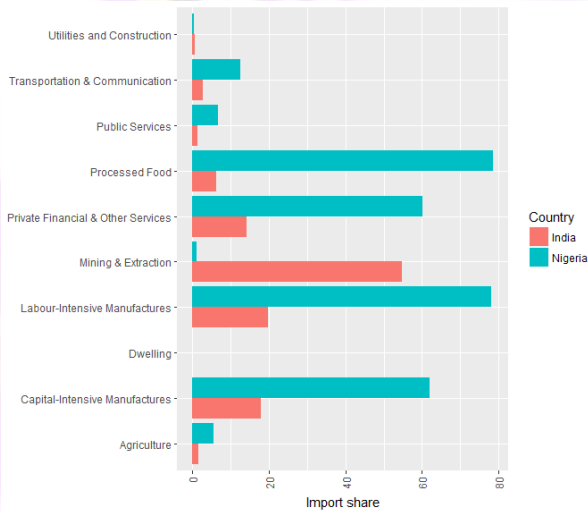


Figure 11 Import share of Nigerian and Indian Economy

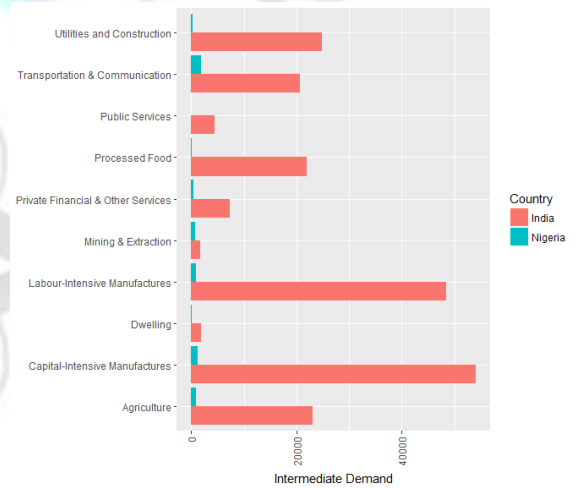


Figure 14 Intermediate demand within the economy of Nigeria and India

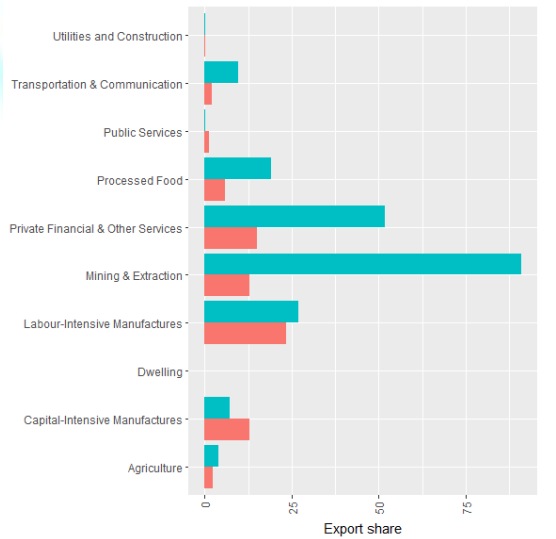


Figure 12 Export share of Nigerian and Indian Economy

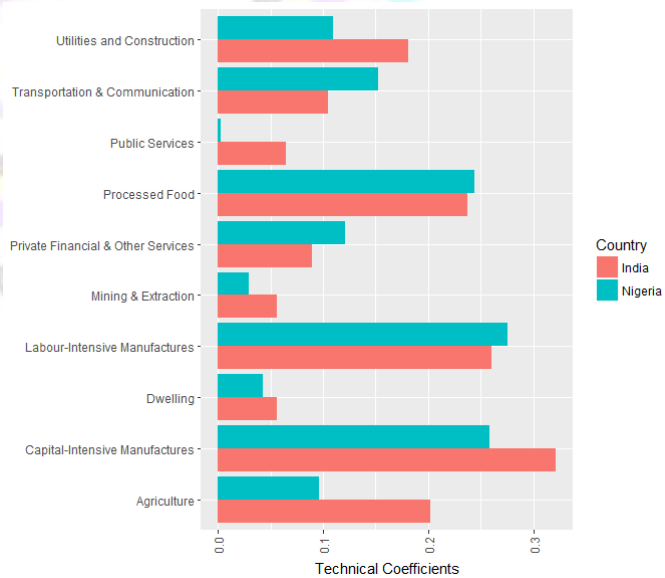


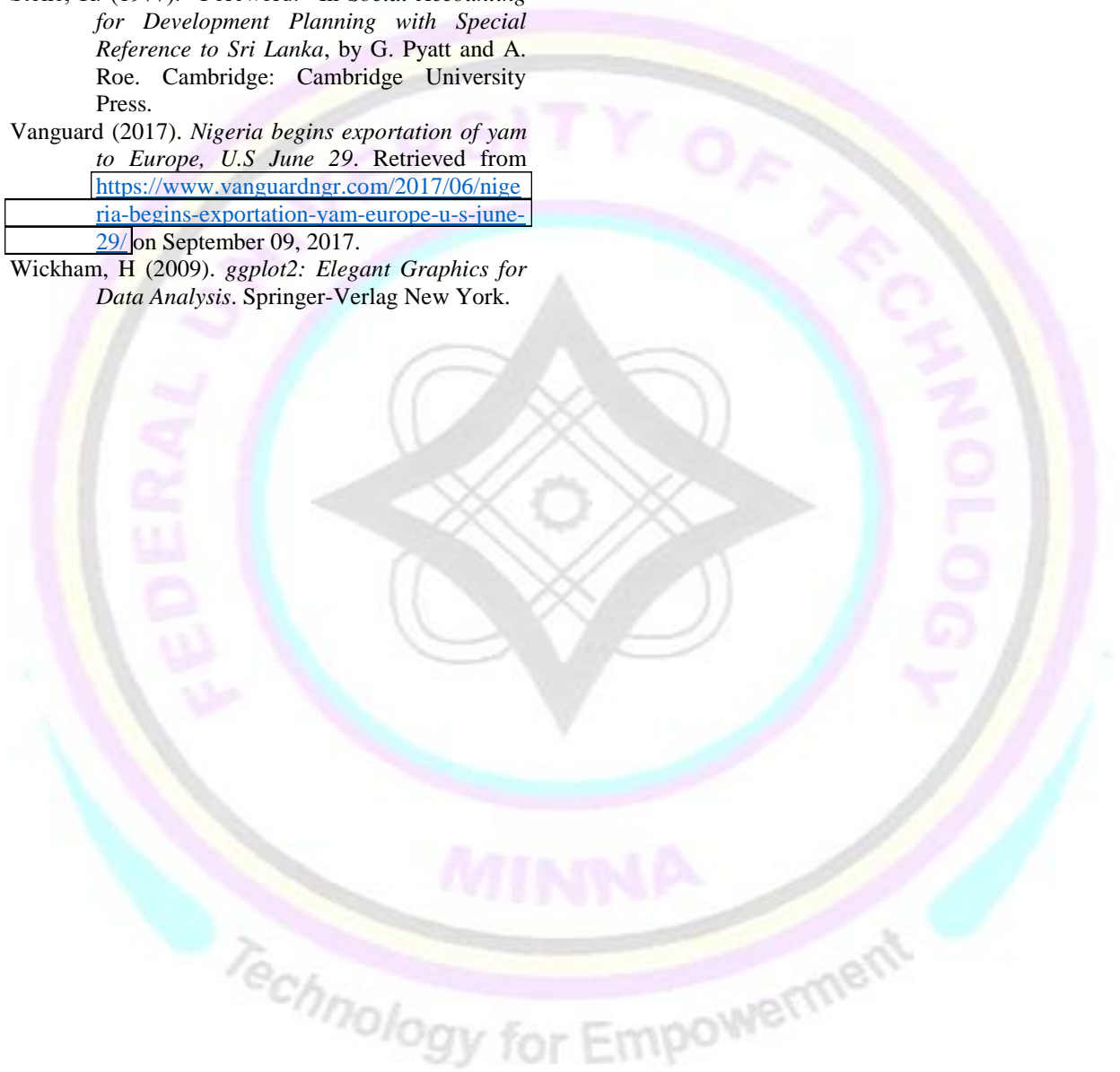
Figure 15 Technical coefficients of the economy of Nigeria and India

## REFERENCES

- Allaire, J.J., J. Cheng, Y. Xie, J. McPherson, W. Chang, J. Allen, H. Wickham, A. Atkins, R. Hyndman & R. Arslan (2017). *rmarkdown: Dynamic Documents for R*. R package version 1.6. <https://CRAN.R-project.org/package=rmarkdown>
- Anonymous (2017). *India-Nigeria Relations*. Retrieved from [https://www.mea.gov.in/Portal/ForeignRelation/Nigeria\\_January\\_2014-1.pdf](https://www.mea.gov.in/Portal/ForeignRelation/Nigeria_January_2014-1.pdf) on September 08, 2017.
- Anonymous (2017a). *Countryeconomy.com*. Retrieved from <http://countryeconomy.com/countries/compare/nigeria/india> on September 08, 2017.
- Badri Narayanan G. & Terrie L. Walmsley, Editors (2008). *Global Trade, Assistance, and Production: The GTAP 7 Data Base*, Center for Global Trade Analysis, Purdue University.
- Badri Narayanan G. & Terrie L. Walmsley, Editors (2008). *Global Trade, Assistance, and Production: The GTAP 7 Data Base*, Center for Global Trade Analysis, Purdue University.
- Bayar, A. H. (2000). *EcoMod7 Module in Practical General Equilibrium Modeling*, EcoMod Modeling School, Northampton, MA, USA.
- Breisinger, C., M. Thomas, and J. Thurlow (2009). *Social accounting matrices and multiplier analysis: An introduction with exercises. Food Security in Practice technical guide 5*. Washington, D.C.: International Food Policy Research Institute. DOI: 10.2499/9780896297838fsp5
- Burfisher, M. E. (2011). *Introduction to Computable General Equilibrium Models*. New York, Cambridge University Press (pp346).
- Burfisher, M. E. (2011). *Introduction to Computable General Equilibrium Models*. New York, Cambridge University Press (pp346).
- Cicowiez, M. & M. V. Sánchez (2012). *The Social Accounting Matrix (SAM): What is it? How is it adapted for MAMS? Presented at the Inception Workshop on "Strengthening Macroeconomic and Social Policy Coherence through Integrated Macro-Micro Modelling"*, Manila, 2-3 October, 2012.
- Erich Neuwirth (2014). *RColorBrewer: ColorBrewer Palettes*. R package version 1.1-2. <https://CRAN.R-project.org/package=RColorBrewer>
- GAMS {General Algebraic Modelling System} (2017). *GAMS Integrated Development Environment version 24.8.5*. Copyright © GAMS Development Corporation, Washington, DC.
- GTAP {Global Trade and Analysis Project} (2017). *Structure Table Template for 10x5 SAM.xls-1725870699*. Retrieved from <https://www.gtap.agecon.purdue.edu/databases/default.asp> on September 05, 2016
- Keyzer, M. A., Merbis, M. D., van Veen, W. C. M., & van Wesenbeeck, C. F. A. (1996). *Construction of a Social Accounting Matrix for Nigeria*. Final report. Volume II: Documentation of the construction. New York: UN/DDSMS, United Nations.
- McDonald, S., & Thierfelder, K. (2004). *Deriving a Global Social Accounting Matrix from GTAP Versions 5 and 6 Data* (GTAP Technical Paper No. 22). Purdue University, West Lafayette, IN: Global Trade Analysis Project (GTAP). Retrieved from [https://www.gtap.agecon.purdue.edu/resources/res\\_display.asp?RecordID=1645](https://www.gtap.agecon.purdue.edu/resources/res_display.asp?RecordID=1645)
- Meade, J., and R. Stone (1940). *National Income and Expenditure*. London: Bowes & Bowes.
- Nwafor, M., X. Diao, V. Alpuerto (2010). "A 2006 Social Accounting Matrix for Nigeria: Methodology and Results", hdl:1902.1/15648, Harvard Dataverse, V5.
- Pal, B. P., S. Pohit & J. Roy (2012). *Social Accounting Matrix for India, Economic Systems Research*, 24(1):77-99. <http://dx.doi.org/10.1080/09535314.2011.618824>
- Pal, B. P., V.P. Ojha, S. Pohit & J. Roy (2015). *Social Accounting Matrix of India: Concepts and Construction in GHG Emissions and Economic Growth, A Computable General Equilibrium Model Based Analysis for*



- India. *India Studies in Business and Economics*. Springer, India. DOI 10.1007/978-81-322-1943-9\_2.
- R Core Team (2017). *R: A language and environment for statistical computing*. R Foundation for Statistical Computing, Vienna, Austria. URL <https://www.R-project.org/>
- Stone, R. (1962). *A Computable Model of Economic Growth*. Cambridge: Chapman & Hall.
- Stone, R. (1977). "Foreword." In *Social Accounting for Development Planning with Special Reference to Sri Lanka*, by G. Pyatt and A. Roe. Cambridge: Cambridge University Press.
- Vanguard (2017). *Nigeria begins exportation of yam to Europe, U.S June 29*. Retrieved from <https://www.vanguardngr.com/2017/06/nigeria-begins-exportation-yam-europe-u-s-june-29/> on September 09, 2017.
- Wickham, H (2009). *ggplot2: Elegant Graphics for Data Analysis*. Springer-Verlag New York.



# GROWTH AND YIELD PERFORMANCE OF SOYBEAN (*Glycine max* [L.] Merrill) GENOTYPES IN MINNA, NIGER STATE

Joseph\*, E.C., K.D. Tolorunse, A., S. Gana

Department of Crop Production,  
Federal University of Technology, Minna.

\*Corresponding Author's E-mail: [ethelchinaza.joseph@gmail.com](mailto:ethelchinaza.joseph@gmail.com), GSM: [08039251146](tel:08039251146)

## ABSTRACT

The study was conducted at the Teaching and Research Farm of the School of Agriculture and Agricultural Technology, Federal University of Technology, Gidan-Kwano campus Minna, Niger state during the 2018 cropping season between July and November 2018 to determine the growth and yield performance of six soybean genotypes. The genotypes were TGx 1987-62F, TGx 1835, TGx 1955, TGx 1951-3F, TGx 1904-6F and TGx 1448-2E. The experiment was laid out in randomized complete block design (RCBD) with 3 replications and a gross and net plot size of 4.5 m<sup>2</sup> and 3 m<sup>2</sup> respectively. Data for emergence percentage, plant height (cm), number of leaves, days to 50 % flowering, number of pods per plant, number of branches and 100-seed weight (g) were collected. Data collected were subjected to analysis of variance (ANOVA) at 5 % probability level.

TGx 1951-3F showed the highest emergence percentage (50.70 %) with early flowering at 49 days after sowing. Among the evaluated genotypes, TGx 1951-3F gave the highest 100 seed weight (13.53 g). This was closely followed by TGx 1904-6F (13.36 g). The genotype TGx 1951-3F which produced the highest 100 seed yield could be selected for further evaluation and cultivation in areas with similar agro-ecological conditions.

**KEYWORDS:** Growth, Yield, Performance, Soybean, Genotype

## INTRODUCTION

Soybean, *Glycine max* [L.] Merrill is an important legume which belongs to the pea family Fabaceae and belongs to the genus *Glycine* Willd (Singh, 2017). Soybeans is said to have originated in Southeast Asia where it was first domesticated by some Chinese farmers around 1100 BC, and was later grown in Japan and many other countries in the first century AD. Soybean is an annual plant. It exhibits taproot growth initially, and later undergoes the development of a large number of secondary roots. These roots establish a symbiotic relationship with the nitrogen fixing bacterium, *Bradyrhizobium aponicum*, through the formation of root nodules (Singh, 2017) and it can supplement nitrogen in cropping systems in subsistence farming and large scale farming involving cereals such as maize, sorghum, millet and others.

It is grown mainly for seed production and is one of the world's leading source of oil and protein, possesses a higher protein content compared to other food crops, it is next to groundnut in oil content among other food legumes (Fekadu *et al.*, 2009). It is also rich in all essential amino acids (except methionine), lipids, vitamins and minerals (Lokuruka, 2010) and is one of the major industrial and food crops grown in Africa (Adama *et al.*, 2015). It is estimated that about 2 % of soybean produced is used as food by humans (Goldsmith, 2008). Soybean

can also be used as cover crop to enrich the soils with nitrogen.

Morphological characteristics focus on physical plant attributes such as plant height, number of leaves, leaf area and days to 50 % flowering. An understanding of morphological characters facilitates the identification, selection of desirable traits, designing of new populations and in transferring their desirable genes into widely grown food legumes through biotechnological means. Resistances to biotic and abiotic stresses that are known to individual accessions increase the importance of the germplasm (Belul *et al.*, 2014). For an effective breeding program, information concerning the extent and nature of variation within a crop species is essential. There is a need to study the agro-biodiversity and best use of the potential of a genotype, this is important in crop improvement. The study of plant material with desired traits by means of identifying morphological characteristics is an essential step for effective utilization of crop germplasm. It is important to know the factors that limit crop success, and it is essential to search for solutions accessing all existing genetic variation both inside and outside the species (Koorneef and Stam 2001). The study was therefore undertaken to determine the growth and yield performance of some soybean genotypes in Minna, Niger state.

## METHODOLOGY

The study was carried out during the cropping season between July and November 2018, at the Teaching and Research Farm of the School of Agriculture and Agricultural Technology in Federal University of Technology, Gidan-Kwano campus located at longitude 09.52935°N and Latitude 006.45025°E 234m above sea level, Minna, Niger State. Six soybean genotypes (TGx 1987-62F, TGx 1835, TGx 1955, TGx 1951-3F, TGx 1904-6F and TGx 1448-2E) obtained from Olam Farms Kaduna were laid out in Randomized Complete Block Design (RCBD) with three replications. A Gross plot size of 1.5 m × 3 m = 4.5 m<sup>2</sup> containing 6 ridges, 1.5 m in length and a net plot of 1.5 m × 2m = 3m<sup>2</sup>. A distance 0.5 m between each plot and 1m between each replication, giving a total experimental area of 12 m × 20.5 m = 246 m<sup>2</sup>. Land preparation was done, after which seeds were sown in inter-row and intra-row spacing of 50 cm and 10 cm respectively, giving a population of 192 plants per plot. Manual weeding was adopted, using hoes at 2, 4 and 6 weeks after planting.

### Data Analysis

Data was collected from five randomly tagged plants within the net plots. Emergence percentage was calculated according to Baset Mia and Shamsuddin, 2009. Plant height (cm) and number of leaves were taken at 4,6, and 8 weeks after sowing, while other parameters taken were; days to 50 % flowering, number of branches, pods per plant and 100-seed weight (g). Data collected were subjected to analysis of variance, while means were separated with Duncan Multiple Range Test (DMRT) using SAS (2008).

## RESULTS AND DISCUSSION

There was significant difference in emergence percentage (Table 1) among the evaluated genotypes. TGx 1951-3F showed the highest emergence percentage (50.70 %), this was closely followed by TGx 1904-6F (45.31 %). The other genotypes (TGx 1955, TGx 1987-62F, TGx 1448-2E and TGx 1835) showed no significant difference ( $p < 0.05$ ) in emergence percentage, however, TGx 1835 recorded the least emergence percentage of 40.12 %. This does not agree with the findings of Talaka *et al.*, (2013), who reported that TGx 1448-2E had the highest germination count. This can be attributed to the difference in genotypes that were used for the study. The variation in germination rate is also dependent on the moisture content of the soil (Hosseini *et al.*, 2009).

There were significant differences ( $p < 0.05$ ) in plant height (Table 2) across the evaluated soybean

genotypes with heights ranging from 29.60 cm to 36.60 cm at 4 weeks after sowing (WAS). Plant heights of TGx 1951-3F (35.70 cm), TGx 1904-6F (36.60 cm) and TGx 1835 (36.53 cm) were statistically at par at 4 WAS. At 6 WAS, TGx 1904-6F maintained the highest plant height (67.63 cm), this was consistent till 8 WAS with the height of 76.27 cm. TGx 1835 recorded a height of 2.23 cm moreover, TGx 1951-3F, TGx 1955, TGx 1987-62F and TGx 1448-2E were statistically similar with plant heights of 61.50 cm, 59.73 cm, 61.83 cm and 61.93 cm respectively. These differences in plant height is in consonance with the study of Talaka *et al.*, (2013) who also observed significant differences among soybean genotypes for plant height.

The data on number of leaves are presented in Table 2. Significant differences ( $p < 0.05$ ) exist in leaf number produced at 4 and 6 WAS. TGx 1904-6F produced the highest number of leaves (24) at 4 WAS with TGx 1955 having the least number of leaves (18). Similarly, at 6 WAS, soybean genotype, TGx 1448-2E recorded the highest number of leaves (85) which was consistently high 2 weeks after with 114 leaf number. Number of leaves was statistically similar at 8WAS but TGx 1955 produced the lowest number of leaves (82).

The data on number of branches, days to 50 % flowering and number of pods per plant (Table 1) showed no significant difference among the tested genotypes. However, TGx 1904-6F produced higher number of branches (18) per plant, this was closely followed by TGx 1835 (17 branches per plant). TGx 1955 and TGx 1448-2E produces the lowest number of branches per plant (11).

Early flowering was observed in soybean genotype TGx 1987-62F (42 days after sowing), TGx 1904-6F and TGx 1835 followed immediately at 50 days after sowing while TGx 1448-2E recorded the highest number of days to 50 % flowering (51). The number of pod per plant ranges between 52 (TGx 1951-3F) to 87 (TGx 1835) pods per plant. However, a significant difference was observed among the genotypes for 100-seed weight, where TGx 1951-3F recorded the highest weight (13.53 g) and TGx 1987-62F had the least (10.54 g). This observation agrees with the finding of Awal (2014) who reported in his study that 100-seed weight of soybean genotypes ranged from 10.57 g to 15.74 g.

## CONCLUSION AND RECOMMENDATIONS

The soybean genotype TGx 1951-3F having shown the higher emergence percentage, number of leaves and great yield can be advanced for further yield



trials alongside TGx 1448-2E which produced greater number of leaves. Seed weight is an important character in any breeding programme owing to its direct effect on crop productivity. This therefore informed the choice of TGx 1951-3F for germplasm improvement. Similarly, the production of high number of leaves is good for cover cropping and will serve as forage sources for animal production with significant effect on sustainable agriculture and food security.



**Table 1:** Emergence percentage, Number of branches, days to 50 % flowering, pod per plant and 100 seed weight from evaluated soybean genotypes

Genotype	Emergence Percentage (%)	No. of branches	Days to 50 % flowering	Pod per plant (no)	100 seed weight (g)
TGx 1951-3F	50.70 <sup>a</sup>	12 <sup>a</sup>	49 <sup>a</sup>	52 <sup>a</sup>	13.53 <sup>a</sup>
TGx 1904-6F	45.31 <sup>ab</sup>	18 <sup>a</sup>	50 <sup>a</sup>	69 <sup>a</sup>	13.36 <sup>a</sup>
TGx 1955	43.57 <sup>b</sup>	11 <sup>a</sup>	45 <sup>a</sup>	56 <sup>a</sup>	11.85 <sup>b</sup>
TGx 1987-62F	43.57 <sup>b</sup>	15 <sup>a</sup>	42 <sup>a</sup>	78 <sup>a</sup>	10.54 <sup>b</sup>
TGx 1448-2E	42.71 <sup>b</sup>	11 <sup>a</sup>	51 <sup>a</sup>	57 <sup>a</sup>	11.09 <sup>b</sup>
TGx 1835	40.12 <sup>b</sup>	17 <sup>a</sup>	50 <sup>a</sup>	87 <sup>a</sup>	12.53 <sup>b</sup>
± SE	2.02	2.47	4.75	16.61	0.66

Means followed by the same letter within the column differ significantly ( $p < 0.05$ ) by Duncan Multiple Range Test (DMRT)

**Table 2:** Plant height per plant and number of leaves per plant from evaluated soybean genotypes

Genotype	Plant height (cm) weeks after sowing			Number of leaves (no.) weeks after sowing		
	4	6	8	4	6	8
TGx 1951-3F	35.70 <sup>a</sup>	57.13 <sup>c</sup>	61.50 <sup>b</sup>	21 <sup>ab</sup>	64 <sup>ab</sup>	86 <sup>a</sup>
TGx 1904-6F	36.60 <sup>a</sup>	67.63 <sup>a</sup>	76.27 <sup>a</sup>	24 <sup>a</sup>	76 <sup>ab</sup>	101 <sup>a</sup>
TGx 1955	32.23 <sup>ab</sup>	54.63 <sup>c</sup>	59.73 <sup>b</sup>	18 <sup>b</sup>	52 <sup>b</sup>	82 <sup>a</sup>
TGx 1987-62F	29.60 <sup>b</sup>	54.47 <sup>c</sup>	61.83 <sup>b</sup>	21 <sup>ab</sup>	60 <sup>ab</sup>	92 <sup>a</sup>
TGx 1448-2E	32.93 <sup>ab</sup>	56.67 <sup>c</sup>	61.93 <sup>b</sup>	22 <sup>ab</sup>	85 <sup>a</sup>	114 <sup>a</sup>
TGx 1835	36.53 <sup>a</sup>	62.40 <sup>b</sup>	72.23 <sup>a</sup>	21 <sup>ab</sup>	70 <sup>ab</sup>	105 <sup>a</sup>
± SE	1.57	1.37	2.57	1.51	8.70	10.42

Means followed by the same letter within the column differ significantly ( $p < 0.05$ ) by Duncan Multiple Range Test (DMRT)

## REFERENCES

- Adama, C.J., Salaudeen, M.T., Ishaq, M.N., Bello, L.Y. and Oyewale, R.O. (2015). Evaluation of *Blackeye Cowpea Mosaic Virus* pathogeneity in soybean. *Nigeria Journal of Agriculture, Food up and Environment [NJAFE]*, 11(4) 39 – 44.
- Awal, A. M. (2014). Grain yield and seed quality of early maturing dwarf soybean genotypes as influenced by planting time and spacing. Ph.D Dissertation. *Department of Agronomy, BSMRAU, Gazipur*. pp. 10-45.
- Baset Mia, M.A. and Shamsuddin, Z.H. (2009). Enhanced emergence and vigour seedling production of rice through growth promoting bacterial inoculation. *Research Journal of Seed Science*, (2), 96-104.
- Belul Gixhari, Hekuran Vrap, Valbona Hobdari. (2014). Morphological characterization of pea (*Pisum sativum* L.) genotypes stored in Albanian genebank. Conference paper. “*Biotechnology in Agriculture*” Agricultural University of Tirana, Albania.

- Fekadu Gurm, Hussein Mohammed and Getinet Alemaw. (2009). Genotype X Environment Interactions and Stability of Soybean Forgrain Yield and Nutrition Quality. *African Crop Science Journal*, Vol. 17, No. 2, pp. 87 – 99.
- Goldsmith, P. (2008). Economics of soybean production, marketing, and utilization. In *Soybeans: Chemistry, Production, Processing, and Utilization*, Eds.
- Hosseini, N.M., Siddique K.H. M., Palta J. A., and Berger J. (2009). Effect of Soil Moisture Content on Seedling Emergence and Early Growth of Some Chickpea (*Cicer arietinum* L.) Genotypes. *Journal of Agricultural Science and Technology*. 11: 401-411
- Koorneef M and Stam P. (2001). Changing paradigms in plant breeding. *Plant Physiology* 125:156–159.
- Lokuruka, M. N. I. (2010). Soybean nutritional properties: the good and the bad about soy foods consumption-a review. *African Journal of Food Agriculture and Nutrition Development*, 10:2439– 2459.
- Singh, R.J. and USDA, (2017). Agricultural Research Service, Soybean/Maize Germplasm, Pathology, and Genetics Research Unit, Department of Crop Sciences, University of Illinois, 1101 West Peabody Drive, Urbana, IL 61801, USA e-mail: [ramsingh@illinois.edu](mailto:ramsingh@illinois.edu).
- Talaka, A., Rajab, Y.S., Mustapha, A.B. (2013). Growth Performance of Five Varieties of Soybean (*Glycine Max.* [L.] Merrill) under Rainfed Condition in Bali Local Government Area of Taraba State-Nigeria. *Journal of Agriculture and Veterinary Science*. 2(4): PP 05-08
- Ugur B, Mehmet S, Abdurrahim T G, Zek M T and Esvet A. (2005). Forage and Grain Performances of Soybean Lines. *Journal of Central European Agriculture*. 6 (3): 397-402.



**ADOPTION OF COWPEA PRODUCTION TECHNOLOGIES AMONG FARMERS IN DEKINA LOCAL GOVERNMENT OF KOGI STATE, NIGERIA.**

**By**

**Emeje Hassan Mohammed, Odoma Micheal Ojodale, Olajide Kolawole**

**Department of Agricultural Education  
Kogi State College of Education (Technical), Kabba.  
Kogi State.**

**Email: [emejegbede@gmail.com](mailto:emejegbede@gmail.com)**

**Phone number: 08060045514**

**Department of Agricultural Education  
Kogi State College of Education (Technical), Kabba.  
Kogi State.**

**Department of Agricultural Education  
Kogi State College of Education (Technical), Kabba.  
Kogi State.**

**Being a Paper presented at the 1<sup>st</sup> International Conference of Agriculture and Agricultural Technology (ICAAT 2018). At the Federal University of Technology, Minna, Nigeria.**

**THEME: FOOD INSECURITY IN AFRICA:  
AGRICULTURAL DIVERSIFICATION AS PANACEA**

**Abstract**

*The study analysed the Adoption of Cowpea Production Technologies among Farmers in Dekina Local Government Area of Kogi State, Nigeria. Data for the study were obtained from 150 respondents selected through multi-stage random sampling. Descriptive statistics were used to categorize respondents. Inferential statistics namely Tobit regression was used to estimate the level of adoption of cowpea production technologies by farmers. The study revealed that majority of the respondents were males (94.7) and married (92%) and fell within the age bracket of 50 years and below (84%). The factors that influenced the level of adoption of cowpea production technologies were education level, level of income and access to credit were found to be significant ( $p \leq 0.01\%$  each). With respect to sources of information, it was found that friends and relations, and personal experience were found to be the main source of information used by farmers. Constraints to adoption of cowpea production technologies were found to be mostly due to lack of inputs, mechanized services, finance, storage facilities and lack of adequate dissemination of information. Based on the finding of this study, the study recommended that, there is a need for re-organizing and*

*intensification of extension services in order to improve their effort towards information dissemination. Also, loans should be made available to farmers so as to enable them procure farm inputs and mechanized services.*

Keywords:

Adoption, Cowpea, Influence, Production, Technologies.

## Introduction

Cowpea is known by other names such as black eye beans, china beans, black eye pea and marble beans and the Igala people call it egwa. It is very important in the socio-cultural and religious life of the people of Kogi State. Among the Okon people of Kabba it is essential in the oro celebration. The making and eating of bean cake is prohibited a week before the festival in honour of the gods to whom it will soon be offered. In Dekina beans and other grains are often offered to the gods and ancestors, sacrifices are not complete without them.

Adoption is a decision made by an individual or group to use an innovation in a continuous manner (Orisakwe and Agomuo, 2011). Technology is the systematic application of scientific or other organized body of knowledge to practical purposes (Orisakwe and Agomuo, 2011). This includes new ideas, inventions, innovations, techniques, methods and materials. The importance of technology to agricultural development especially in less developed countries is widely recognized. This is predicted on the observed impact of technology and its potential and actual contribution to the development of agriculture. In developing countries like Nigeria where a greater proportion of the population live in rural areas, agricultural technology could provide a potential means of increasing production and subsequently raising income of the farmers as well as their standard of living (Yindau, 2014) cited in (Bashir, et al., 2018). Cowpea (*vigna unguiculata (L) walp*) is a leguminous crop grown mainly in the savanna regions of the tropics and subtropics of Africa, Asia and South America (Sani *et al.*, 2014). Being a drought tolerant and warm weather crop cowpea is well adapted to the drier region of the tropics where other food legumes do not perform well. It is of major importance to the livelihoods of millions of people in less developed countries of the tropics, particularly in Asia and Africa. From its production, rural families derive food, animal feed and income (IITA, 2009). Cowpea is also one of the most importance economic crops in the tropics for the fact that all of its parts are useful for human consumption and for the provision of livestock feed. The crop tolerates drought and performs well in a wide variety

of soil. Similarly, the bacteria in the root nodules contribute to soil fertility through fixation of nitrogen in the soil and production of organic matter (Tijjani *et al.*, 2015).

However, with the numerous benefits derived from adopting improved cowpea production technologies farmers can improve their income and better their living standard. But many farmers are not aware of these technologies. Even with the popularity and diverse benefits of cowpea production technologies it seems that several farmers have not adopted it. Due to the importance of cowpea in the life of the people of the study area it is germane to intensify its production by adoption and use of these technologies. This study is therefore, needed as it seeks to assess the adoption of cowpea production technologies among farmers in Dekina Local Government Area of Kogi State. Therefore, the objective is to:

- i. Describe the socio-economic characteristics of the cowpea farmers;
- ii. Determine the factors that influenced adoption of cowpea production technologies among the farmers;
- iii. Identify cowpea production technologies available to the farmers;
- iv. Assess farmers' extent of adoption of cowpea production technologies; and
- v. identify the constraints experienced by the farmers in the adoption cowpea technologies

## II. Methodology

### The Study Area

The study area is Dekina Local Government Area of Kogi State. It is one of the nine local government areas in Kogi East senatorial District. It has a population of 66,801 out of which 31,839 are males and 34,962 are females. About 4,356 of the population are between 7 and 14 years of age and 18,141 are between 15 and 49 years (Omale 2004.). This gives a ratio of 1:1.1.

The study area is predominantly rural in nature. Streams like Okura, Ofu, and Itemie serve as the major sources of household water in the area. The major crops produced are yam, cassava, maize, cowpea and bambara nut. Tree crops include oil

palm, citrus, mango, and cashew. The climate is tropical with a mean temperature of about 30°C during the hottest period of January to April. The mean temperature during the coldest period of December to January is about 21°C. The area is generally cool during the rainy season, with a mean annual rainfall of between 1500mm and 1800mm. The rainfall is seasonal with most of it between April and October. This pattern of rainfall dictates the farming season. There are two seasons in a year, the early season from April to August and the second season from August to October.

The vegetation is of the derived savannah type. The soil type is influenced by hydrological conditions, which are related to topographic conditions, which are related to the geology of the area. Ankpa and Dekina are plateau Divisions (Felton, 1979). The soil is classified as hydromorphic and derived from sandstone. This may lend credence to the presence of quarries in the area. The soil is generally hard to till.

The study area is bounded in the north by Bassa Local Government Area, North-east by Omala and Ankpa Local Government Areas and in the South by Ofu and Olamaboro Local Government Areas, respectively.

#### Sources of Data and Sampling Procedure

Primary and secondary data were used for this study; the data were collected with the use of a structured questionnaire which was pre-tested using smaller group to ensure its reliability, before the final administration to respondents that were sampled in the study area on scheduled arrangement basis. The populations for the study were cowpea farmers in Dekina Local Government Area of Kogi State. In this study, Purposive and multi stage random sampling techniques were adopted in the selection of respondents. In the first stage, the three districts in the study area were purposively selected. This includes Biraidu, Dekina and Okura. In the second stage 5 villages were randomly selected from each of the districts giving 15 villages all together. These are from Dekina, Odoate, Odu ofomu, Oganenigu, Iyale and Oloba; from Biraidu, we have Araba salifu, Emewe-efopa, Abocho etiaja Ogbabede and Biraidu-abocho; from Okura we selected Itama, Okura sawmill, Ochaja, Agala-ate, and Abejukolo-egume. In the third stage, snow ball technique was used to select 10 respondents from each of the selected villages. In all 150 respondents were selected for the study.

#### Analytical Techniques

The data collected for this study was analyzed based on the number of questionnaires retrieved from the respondents. The data was subjected to descriptive statistics using frequency,

percentages and Mean for objectives I, III, IV and V while objectives II was analyzed using logit multiple regression. {Software used in the analysis was special package for social science (SPSS)}. **Mean**  $X = \frac{\sum fn}{n}$  where

$X$  = Mean score  $\Sigma$  = Summation  $F$  = frequency of response mode  $n$  = likert nominal value  $N_r$  = number of response. The decision rule that served as basis for acceptance or rejection was determined thus; Decision rule (DR) of 3- point rating scale =  $(3 + 2 + 1)/3 = 2.0$  The rating scale was used to determine the problem encountered by the farmers in the study area. A 3-point rating scale was used as follows, very severe 3, severe 2, not severe 1. To determine the cutoff point, a class interval of 0.05 was used to determine the upper limit of the mean. The upper limit  $2.0 + 0.05 = 2.05$  The lower limit  $2.0 - 0.05 = 1.95$  Therefore responses with mean score  $X$  up to the above 2.00 were regarded as good while those mean score  $X$  below 1.95 were regarded as not so strong or good. Regression model is the situation in which dependent variable (P) is predicted from two or more independent variables. It is used to determine the contributions of independent variables to the dependent variables. To determine the magnitude of each cowpea technology in explaining the variation in total adoption, the total adoption scores of the respondents were regressed on the adoption scores for various cowpea technologies. The order in which the technology was selected gives valuable information on the contribution of each technology in explaining the differences in total adoption of the farmers. This is why regression model were used in this study to analyze the factors that influence adoption of cowpea production technologies. The Multiple Logistic Regression Model is explicitly specified as follows:

$$P = \frac{\exp(b_0 + b_1X_1 + b_2X_2 + \dots + b_pX_p)}{1 + \exp(b_0 + b_1X_1 + b_2X_2 + \dots + b_pX_p)}$$

Where: P = Adoption of recommended cowpea production practices (total number of recommended cowpea production practices adopted).  $X_1 - X_n$  = Independent variables  $X_1$  = Age (in years)  $X_2$  = Gender (male=1, female=0)  $X_3$  = Marital Status (Dummy: married = 1, single= 0)  $X_4$  = Farm size (hectares)  $X_5$  = Educational level (number of years in formal schooling)  $X_6$  = Farming experience (number of years in cowpea production)  $X_7$  = Household size (number of people in the household)  $X_8$  = Extension contact (number of visits in 2015)  $b_1 - b_8$  = Regression coefficients  $U$  = Error term

### III. Results and Discussion

#### Socio-economic Characteristics of the Respondents



### **Age distribution of the Respondents**

Farmers age is said to influence farmers' maturity and decision making ability (Sani *et al.*;2014). Result of the study in Table 1 show that 2.3% of the farmers were below 30 years of age. Those that fell within the age range of 30 – 49 years accounted for 69.3 %, about 18% of the respondents were of the age range of 50 - 59 years, while about 11% of the respondents were either 60 years of age or more. The average age of the respondents was about 45 years. The implication of these findings is that majority of the respondents belong to the young and middle-aged group. This is an advantage since they are supposed to be physically able and more mentally alert in learning new technologies than the older farmers. It implied that farming was embraced by all the age group in the study area which is an advantage for increased investment. This finding is similar to that of Sani *et al.*; (2014) which indicated a relatively widespread dual purpose cowpea production among age group of farmers in Bichi Local Government Area of Kano State.

### **Gender of the Respondents**

As shown in table 1 majority of the respondents (94.7%) were male, this implies cowpea production is dominated by male in the study. This is in agreement with the finding of Ayode, (2010) which showed that male predominated in the effectiveness of information sources on improved farm practices among cowpea farmers in Oyo State, Nigeria.

### **Marital Status of the Respondents**

Table 1 shows that majority (92%) of the respondents were married while others were single and widow(er) respectively. This means that majority of the cowpea farmers in the area were married. The high proportion of the respondents who were married is an indication that family labour could be available for cowpea farmers in the study area. This finding agreed with Abah and Tor, (2012) were they found that most of the cowpea farmers in Lafia Local Government of Nassarawa State were married.

### **Respondents Educational Attainment**

It is a well-known fact that, literacy level in rural Nigeria is low. The result obtained from this finding, therefore, is not much different from what is expected. Table 1 indicates that most of the respondents (56.67%) had not acquired formal

education. They cannot easily understand and adopt innovations. This finding is in agreement with that of Onweremadu and Mathew (2007), and Sani *et al.*, (2014).

### **Respondents Farm Size**

By classification of Shaib *et al.*; (1997) cited in Agwu (2004), farm holdings in Nigeria fall into three broad categories namely: small scale, medium scale and large scale. Small Scale farmers are the majority (88%) of the respondents cultivate 0.10 – 5.99 hectares, while 9.34% and 2.66 are medium and large scale farmers cultivating 5-10 and above 10 hectares respectively. These finding differ from the finding of Agwu and Anyanwu, (1996) cited in Agwu (2004) that, cowpea farmers in south eastern Nigeria cultivated not more than 1.5 hectares. This implies that farmers in Taraba State cultivate relatively larger hectares than their counterparts in south eastern Nigeria. This may be for the fact that there is availability of land space in northern Nigeria. This is an advantage for adoption of modern cowpea production technologies.

### **Respondents Household Size**

Most rural households in Nigeria are large because of the extended family system Gbadegesin and Olorunfemi (2007). It is not surprising therefore that, more than half (56.8%) of the respondents' household had between 6 – 20 or more members with the mean household size of 13 members as show in Table 1. This finding closely related to Sani *et al.*; (2014) who reported 8 persons as an average household size in the adoption of dual purpose cowpea production. Ekwe and Nwachukwu, (2006) also reported that the average household size in Africa was 8-9 persons per household. Households provide ready source of labour on the farm, this is an indication of why farmers tend to take more than one wife. (Onuche *et al.*, 2014), observed that household size has implications for labour availability and could influence the likelihood of innovation adoption especially in relation to the financial status of the family. (Orebiyi *et al.*, 2011) viewed this from different angle as he reported that large family size may mean more family expenses and fewer funds for agricultural activities especially adoption of technologies which has financial implications. The implication here is that while large family can provide farm labour it is also expensive to maintain; both may give reason for non-adoption of technologies. Family labour is an important component for small-scale farm holders.

### **Respondents Farming Experience**

As indicated in Table 1, Majority (53.9%) of the respondents had 6-15 years of farming experience. The mean farming experience was 11years. This indicated that, the farmers were experienced enough to be able to understand the technologies and adopt it. The length of experience in farming is probably an indicator of a farmer's commitment to agriculture. It may not necessarily pre-dispose them to adoption of new practices. It is more logical to expect veteran farmers to be less receptive to innovation. Long farming experience is an advantage for increasing farm productivity since it encourages rapid adoption of farm innovation, long experience according to Obinne (1991) and Sani *et al.*; (2014) is an advantage for increasing farm productivity. This also implies that majority of the cowpea farmers had long period of farming experience and therefore would be conversant with constraints to increased cowpea production. This could increase their level of acceptance of new ideas as a means of overcoming their production constraints and hence could serve as an advantage for increased cowpea production.

### Respondents Access to Extension Service

Adoption of cowpea production technologies is highly facilitated by the efforts of extension workers in introducing and demonstrating to the farmer how to use the technologies (Bzugu and Gwary, 2004 cited in Tijjani *et al.*, 2015). However, all (100%) respondents indicated they had no contact with the extension agents but adopt the practice on their own or with the help of fellow farmers. This lack of farmers contact with extension agents negates the theoretical role extension agencies supposed to play in technology diffusion and adoption Tijjani *et al.*, (2015) which may be due to inadequacy or insufficient logistics for the extension worker to reach the farmer or incompetency of the personnel to be conversant with technical aspect of the technology. Also, an extension officer informed the researcher that the Kogi ADP lacks staff. He said that over the years the organization have loss staff to death and retirement without replacement so that she lacks the agents to reach farmers in the various zones in Kogi State and the study area in particular.

**Table 1: Distribution of Respondents based on Socio-economic Characteristics (n=150)**

Socio-economic Variables	Frequency (F)	Percentage (%)
<b>Age(Years)</b>		
20 – 29	28	18.7
30 – 39	69	46.0
40 – 49	29	19.3
50 – 59	17	11.3
> 60	7	4.7
<b>Gender</b>		
Male	142	94.7
Female	8	5.3
<b>Marital Status</b>		
Married	138	92.0
Single	8	5.3
Widow(er)	4	2.7
Divorce	-	-
<b>Educational Level</b>		
No formal Education	85	56.67
Primary Education	25	16.7
Secondary Education	33	22.0
Tertiary Education	7	4.6
<b>Farm Size</b>		
0.1 – 5.99	132	88.0
6 – 9.99	7	4.67
10 – 15.99	7	4.67
16 – 20	2	1.33
> 20	2	1.33
<b>Household Size</b>		
1 – 5	56	37.8
6 – 10	64	43.2

11 – 15	16	10.7
16 – 20	6	4.1
> 20	6	4.1
<b>Years of Farming Experience</b>		
1 – 5	18	12.0
6 – 10	47	31.3
11 – 15	35	23.3
16 – 20	18	12.0
> 20	32	21.3
<b>Access to Extension Service</b>		
Yes	0	0
No	150	150

**Source:** Field Survey, 2017.

### Cowpea Production Technologies

The percentage of the adoption rate of the eleven-cowpea production technologies among farmers are presented in Table 2, highest (99.3%) adoption percentage was recorded for land preparation. This is not surprising as it is well known that, the yields of cowpea varieties are generally decreases without proper land clearing and cultivation procedures. Hence, the high level of adoption associated with this technology implies that farmers in the study area were aware of the fact that without proper land preparation in their cowpea farms they cannot make good economic gains.

Recommended spacing and planting date and storage techniques recorded 98.7% and 97.3% respectively while used of herbicide for weed control and seed rate recorded 95.3% and 90.7% respectively. For mechanize farming use of tractor for land preparation and pesticide to control pest on cowpea farms recorded 2.6% and 96% respectively. Field practices showed that farmers in this area cultivate their farm lands manually often achieving this through cooperative farming. Furthermore, fertilizer application and seed treatment recorded 5.3% and 36% respectively. The low adoption 8% recorded for improves seed may be associated to the low level of awareness of the technology among the respondents.

**Table 2: Cowpea Production Technologies (n = 150)**

Technologies	Frequencies	Percentage	Ranking
Land preparation	149	99.3	1
Spacing and Planting Date	148	98.7	2
Storage	146	97.3	3
Pesticide	144	96	4
Herbicide	143	95.3	5
Seed rate	136	90.7	6
Harvesting	102	68.0	7
Seed Treatment	54	36.0	8
Improved seed	12	8.0	9
Fertilizer application	8	5.3	10
Mechanized farming	4	2.6	11

**Source:** Field Survey, 2017.

### Extent of Adoption of Cowpea Production Technologies

The extent of adoption of cowpea production technologies among the respondents is discusses in this section. Using a five steps (awareness to

adoption) adoption model; the following cowpea production technologies packages are discussed here; used of improved seeds, herbicide, pesticide, seed treatment, mechanized farming, spacing and planting date, fertilizer application, land preparation and seed rate.



### **Adoption of Improved Seed**

Table 3 revealed that 56.7% of the respondents were aware of the improved cowpea varieties but are yet to start using it, 26.7% and 5.3% were at the interest and evaluation stage. About 3.3% of the respondents were at the trial stage in the adoption of this technology while 8% of the farmers have already adopted the technology. This means that majority of the respondents were yet to adopt the use of improved cowpea varieties. Cowpea varieties introduced in the study area include; IT 94K-440-3, IT 90K-82-2, IT93- 452-1 and IT 96D-757. Extension workers need to work at improving the levels of awareness of this practice based on the fact that when there is an increase in the awareness of the practices by the farmers, it might increase the adoption rate of the technology.

### **Adoption of Herbicides as Measures for Controlling Weeds**

Table 3 also shows that, majority (99.3%) of the farmers have adopted herbicide as one of the major means of controlling weeds. None of the respondents was of the awareness, interest and evaluation of these technologies. 0.7% were at the trial stage, this means that majority of the respondents applied herbicides in their farms to control weeds.

### **Adoption of Pesticide as Measure for Controlling Insect Pest**

Based on the analysis in Table 3, it could be depicted that 74.7% of the respondents adopted the recommended pest control measure on their farms. About 14.6% were at trial while 6.7% were at evaluation stage those who were at the interest stage constituted 2.7% of the respondents, with 1.3% being at the awareness stage. This indicated that all farmers are in one stage or the other in the adoption of pest control measures. Insect pests and diseases are harmful to cowpea plants and the products, therefore, farmers applied chemicals on the plants and after harvest before storage (postharvest treatment). Most of the respondents reported to have adopted the use of chemicals on farms and during post-harvest storage.

### **Adoption of Seed Treatment**

Furthermore, table 3 indicated that majority (64%) of the farmers are at the awareness stage of the practice while 36% had adopted the practice. The reason for this level of adoption could be that the

practice was simple due to lack of extension contact. The few respondents that have adopted the technology revealed that it is very effective in controlling insect, rodents and birds that hinders the germination of the seeds after sowing. Respondents also said that they treated cowpea seed with chemicals such as FANASON D., Apron-Plus and Aldrex T. This is to avoid pests and diseases attack.

### **Adoption of Mechanized Farming**

Based on the revelation from Table 3, the majority (96.6%) is on awareness; they have not adopted the technology of using tractors for land preparation; the use of hoes was more popular among the farmers. Only (0.7%) are on interest; evaluation and adoption while 1.3% are on trial stage of their technology. These could be attributed to the fact that majority of the farmers own from 0.1 to 5.99 hectares and may not require tractors to cultivate their farm lands.

### **Adoption of Spacing and Planting Date of Cowpea**

The recommended date for planting of cowpea in the study area is early August through September. This is when the rain is relatively steady. Table 3 shows that 64% of the farmers had adopted the recommended term for planting of cowpea, 4.7% were aware of the technology, 9.3% were at the interest stage while 16.7% and 5.3% were at the evaluation and trial stage respectively. This means that majority of the respondents have adopted the term of cowpea planting in the zone. Cowpea requires a seed rate of approximately 25.30kg/ha (viable seeds) with a spacing of 20 x 75cm for erect varieties and 50 x 75cm for the spread types at 2 seeds per hole 4-5 cm depth.

### **Adoption of Fertilizer Application**

The recommended inorganic fertilizer rates for cowpea production are single super phosphate before planting at 200kg/ha-1. Table3 indicated that 58.7% of the respondents were aware of the technology, 18% are at the interest stage of the adoption of inorganic fertilizer application rate for cowpea production. About 10% and 5.3% were at the evaluation and trial stage respectively while just few (8%) had adopted the technology. The farmers indicated that the soil was fertile enough for cowpea production and the use inorganic fertilizer on their cowpea farms will encourage vegetative growth but poor pod production.

### Adoption of Land Preparation

Notwithstanding, table 3 highlighted that 98.7% of the farmers had adopted land preparation. 1.3% was at trial stage none of the respondent was at the stage of awareness, interest and evaluation of this technology. This shows that majority of the respondents practice land preparation on their cowpea farm before planting. Field clearing is done by the use of cutlasses and hoes as reported by the respondents.

### Adoption of Seed Rate

Finally, table 3 showed the distribution of farmers based on the stages in the adoption of seed rate as planting material for cowpea production. The recommended seed rates are 2 to 3 seeds per hole. The table shows that majority of the respondents 96.5 had adopted 1.3% of the respondents were at the evaluation and 2% were at the trial stage while none of the respondents were at the awareness and interest stage.

**Table 3: Extent of Adoption of Cowpea Production Technology**

Cowpea Technologies	Stages of Adoption				
	Awareness	Interest	Evaluation	Trial	Adoption
Improved seed	56.7	26.7	5.3	3.3	8
Herbicides	0	0	0	0.7	99.3
Pesticides	1.3	2.7	6.7	14.6	74.7
Seed treatment	64	0	0	0	36
Mechanized farming	96.6	0.7	0.7	1.3	0.7
Spacing and Planting date	4.7	9.3	16.7	5.3	64
Fertilizer application	58.7	18	10	5.3	8
Land preparation method	0	0	0	1.3	98.7
Seed rate	0	0	1.3	2	96.7

**Source:** Field Survey, 2017.

### Logit multiple Regression of Some Variables Influencing Adoption of Cowpea Production Technologies among Farmers in the Study Area.

The factors influencing the adoption of cowpea production technologies were evaluated using multiple (Logit) regression analysis where four functional forms were tried and linear function gave the best fit. The result is presented in table 4 which revealed that the coefficient of multiple determinations (R<sup>2</sup>) was 0.79 implying that about 79% of the variations in the adoption of cowpea production technologies were explained by variables in the models. Z value was statistically significant at 1% which also showed model fit.

The coefficient for (X<sub>1</sub>) was positive and statistically significant at 1%. The positive coefficient of age means that there is direct relationship between adoption of cowpea production technologies and age of the farmers. Age is said to be primarily latent characteristics in adoption decisions. However, there is contention on the direction of the effect of age on adoption. Age was found to positively influence adoption of cowpea. The farmers' age can increase or decrease the probability of adopting cowpea

production technologies. The coefficient of gender was negative and not statistically significant. This implies that gender is not a factor influencing adoption of cowpea production technologies in the study area. This agrees with the appriori expectation that irrespective of one gender he or she could adopt cowpea production technologies. There was a positive significant relationship between marital status (X<sub>3</sub>) and adoption of cowpea production technologies in the study area. This could be explained for the fact that, married farmers have more responsibilities to catered for their families which could stimulate them to adopt the new technologies in order to enhance their farm yield. The coefficient of household size was positive and statistically significant at 1% level. This agrees with the appriori expectation, that the large household size could supply cheap family labour which positively enhances adoption of cowpea production technologies in the study area. The coefficient of educational level (X<sub>5</sub>) was also found to be positive and statistically significant at 1%. The positive coefficient of educational status means that there is a direct relationship between adoption of cowpea

production technologies and educational status, whereby as educational status increased adoption level also increased among farmers. This agreed with appriori expectation that the higher the educational level the higher the level of adoption. Low level of education of the farmers is inimical to the adoption of innovation especially for technologies that are complex. The coefficient in farm size was positive and statistically significant at 1% level. The positive coefficient implies a direct relationship that as farm size increases, adoption of cowpea production technologies increase and vice-versa. In other word, the larger the farm size the higher the potential of adoption, these agree with the appriori expectation that large farmers adopt improved technologies at a faster rate than small farmers. It will be difficult to used mechanized farming system on small and fragmented individual farms. Small scale farmers live at subsistence level and are usually financially disadvantaged. These financial constraints may discourage them from adopting improved technologies. The table also revealed that years of farming experience was found to be important in influencing the likelihood of adoption of cowpea production technologies. The variables were found to be statistically significant at 1% level and positively

related with likelihood of adoption. Most farmers fear trying improved technology because they do not have previous experience in applying the new technology and due the possible risk of failure. Years of farming experience could enable the farmers to have courage in adopting the technology as it confirmed appriori expectation. However, the studies of Ajala (1992) and Ikini *et al*; (1998) cited in Agwu (2004) show that age, farming experience and organizational participation significantly influenced adoption. The difference might be the type of technologies studied among other factors. Furthermore, this result conformed to the findings of Salau *et al*; (2010) who reported in their study of assessing adoption level of diffused light storage technology among irish potato farmers in Jos South Local Government Area of Plateau State. The logistic regression result showed that farmer's age, education, income and farm size are significant determinants of adoption. Similarly, Isibor and Ugwumba (2014) applied logistic regression model in their study on adoption of oil palm production technologies in Ihiala Local Government of Anambra State, Nigeria. The found out that farm size, educational level and annual farm income were positively significant.

**Table 4: Logit Multiple Regression Result of some Factors that influenced Adoption of Cowpea Production**

**Technologies**

Variables	Regression Coefficient	Standard Error	Z-Statistics	Prob.
X1(Age)	0.119036	0.234414	0.5077800	0.0016**
X2 (Gender)	-0.023008	0.284920	-0.08752	0.1256
X3 (Marital Status)	6.076718	0.173239	0.442848	0.6579
X4 (Household Size)	9.019533	0.205743	0.094939	0.0004**
X5 (Level of Education)	21.026517	0.161526	0.164168	0.0016**
X6 (Farm Size)	10.0196631	0.082606	0.237648	0.0022**
X7 (Farming Experience)	0.053827	0.166034	0.324189	0.0058**
C	-3.067822	6.759884	0.453828	0.0002
R – Squared	0.794265			
Adjusted R – Squared	0.782083			
F – Value	65.20157			

1%level of significance\*\*

Source: Field Survey Data, 2017.

**Constraint Affecting the Adoption of Cowpea Production Technologies**

This section discusses the constraint affecting the adoption of cowpea technologies by the farmers. The constraints discussed here are in adequate funds, high cost farm inputs, high cost of labour, lack of improvedseeds, poor price of the product, inadequate storage facilities, pest and disease attack, inadequate

transportation facilities, unfavourable weather condition, lack of awareness and harvesting problems. The result in table 5, shows that inadequate funds is the most very severe constraints encountered by cowpea farmers in the study area which ranked first with a means score of( 2.82), follow by high cost of labour 2.31, high cost of farm inputs 2.26, harvesting problem 2.16, lack of improved seed 2.08,



pest and disease attack 2.04, inadequate storage facilities 1.81, lack of awareness 1.78, inadequate transportation facilities 1.74, unfavourable weather condition 1.41, and poor price of the product 1.36 respectively. This implies that inadequate fund is the most severe problem encountered by cowpea producers in the study area. The result concurred with

that of Ibrahim *et al.*, (2016) and Bashir, et. al. (2018) they observed that lack of input, financial constraint, poor storage facilities and lack of implement were the major constraint to adoption of cowpea production technologies among farmers in Askira/Uba Local Government area of Borno State Nigeria, and Farmers in Taraba State, Nigeria respectively.

**Table 5: Distribution of the respondents based on the constraints experienced in the adoption of cowpea production technologies.**

Constraints	Very Severe	Severe	Not Severe	Score	Ranking
Inadequate funds	127(84.6)	19(12.7)	4(2.7)	2.82	1
High cost of farm inputs	46(30.7)	98(65.3)	6(4)	2.26	3
High cost of labour	53 (35.3)	91 (60.7)	6 (4)	2.31	2
Lack of improved seed	49 (32.7)	65 (43.8)	36 (24)	2.08	5
Poor price of the product	6 (4)	87 (87.3)	13 (8.7)	1.36	11
Inadequate storage facilities	11 (7.3)	110 (73.3)	19 (12.7)	1.81	7
Pest and Disease attack	37 (24.7)	88 (58.7)	25 (16.6)	2.04	6
Inadequate transport facilities	11 (7.3)	89 (59.3)	50 (33.3)	1.74	9
Unfavourable Weather.	11 (7.3)	40 (26.7)	99 (66)	1.41	10
Lack of Awareness	17 (11.3)	84 (56)	49 (32.7)	1.78	8
Harvesting Problem	18 (12)	128 (85.3)	14 (9.3)	2.16	4

Source: Field Survey, 2017.

#### IV. Conclusion

Based on the major findings of the study, the following conclusion and implication are deduced. Majority of the farmers were middle-aged and largely illiterate, implying that, many of them were not in a good position to be aware of, understand and adopt the cowpea production technologies. They were predominantly males, with long period of farming experience. Also, most of them were married and had average household size of six members, which is fairly large. This is expected to serve as an incentive to continue adoption of cowpea production technologies since supply of labour is ensured. The farmers also had mostly small farm holdings and indicated never to have contact with extension. In terms of the level of awareness of the cowpea production technologies, majority of the farmers were aware of cowpea production technologies. With regard to the extent of adoption of cowpea production technologies majority of the farmers had adopted herbicide, pesticide, while others are at the awareness, interest, and evaluation and trial stage of the technologies. This implies that the extent of adoption of the cowpea production technologies was fairly good. The variable which significantly influenced the adoption of the cowpea production technologies were age, marital status, level of education, farms size and years of farming experiences. The study concluded that there is

production complexity problem, economic problems, poor technical information and pathological problems constraining the increase adoption of the cowpea production technologies. This suggest the need for researchers, policy makers and administrators of extension services to consider seriously these issue which constitute limiting factors to increase cowpea production in the study area.

#### V. Recommendations

Based on the findings of this study, the following recommendations were put forward:

- i. The extension agents should use the group approach in extension service delivery and identify farmers that should be taught the technical skill involved in the cowpea production technologies. In this way a large number of farmers would be reached at the same time. These farmers would in turn teach these technologies to other farmers in the area.
- ii. The poor economic condition of the farmers occasioned by lack of funds to carryout necessary farm activities associated with cowpea production technologies, among other variables, was major constraints to the production capacity of the farmer were handicapped in this area. Thus, even though the issue of provision of credit is an intractable problem in Nigeria agriculture, it is suggested that a realistic policy on provision of credit to cowpea farmers in particular be put in place. The Government may have to revisit this issue. Once this is done, the credit

facilities must be accompanied with supervision and advice from the disbursing agency to ensure their proper utilization for increase cowpea production.

iii. Farmers should be encouraged to participate actively in farmers/social organization and co-operative societies in order to strengthen their group action, since such organization act as effective channels for extension contact with larger number of farmers. It also creates opportunity for participatory interaction of farmers with extension organization further more. Co-operative societies help in providing marketing facilities for the mutual benefit of the famers.

iv. Loans should be made available to farmers so as to enable them procure farm inputs and mechanized services for improved agricultural production. Farm inputs such as fertilizers, chemicals and improved seeds should be made available to farmers at subsidized rate before the onset of rainy season by government.

v. Modern storage facilities should be introduced to farmers in order to reduce post-harvest loss as a result of pest attack.

#### References

- Agwu, A.E. (2004). Factors affecting adoption of improved cowpea production technologies in Nigeria. *J. Int. Agric. Ext. Educ.* 11(1):81-88.
- Bashir, M.B., Ndaghu, A.A., Nakwe, S.H.G., Abdulazeez, A.W. and Samuel, R.T. (2018) "Adoption of Cowpea Production Technologies Among Farmers in Taraba State, Nigeria." *IOSR Journal of Agriculture and Veterinary Science (IOSR-JAVS)* 11.3 (2018): 37-46.
- Bzugu and Gwary, 2004 cited in Tijjani, A. R. Nabinta, R. T. Muntaka, M. (2015) *Adoption of innovative cowpea production practices in a rural area of Katsina State, Nigeria.* *Journal of Agricultural and Crop Research* Vol. 3(4), pp. 53-58, June 2015 ISSN: 2384-731X
- Ekwe, K.C, and Nwachukwu, I. (2006) Influence of household factors on the utilization of Garri processing technologies in southern Nigeria. *Journal of Agricultural Extension* 9:134-141
- Gbadegesin, N, and Olorunfemi, F. (2007) Assessment of rural water supply management in selected rural area of Oyo State, Nigeria. *African technology policy studies Networking paper series* No. 49:64.
- Ibrahim, A. A., Wabab, S. Y., Mohammed, N. and Mustaphaa, S. B. (2016). Factors Influencing the Level of Adoption of Cowpea Production Technologies in Askira/Uba Local Government Area of Borno State, Nigeria. *International Academic Journal of Innovative Research* Vol. 3, No. 9, 2016, pp. 15-23. ISSN 2454-390X
- IITA. (2009) *Cowpea project for Africa Research and Development.* International Institute of Tropical Agriculture. Available at: <http://www.iita.org/crop/cowpea>
- Ikini, E. I., Annatte, A. I. Umaru, M., & Jegede, O.C. (1998). Study of extent of adoption of cockeret exchange technology (CET) by rural farmers in Adamawa State of Nigeria. *Proceedings of the Siver Anniversary Conference of the Nigeria Society for Animal Production (NSAP).* 21 -26 March 1998.
- Isibor, A.C. and Ugwumba, C. O. A. (2014) Adoption of Oil Palm Production Technologies in Ihiala Local Government of Anambra State, Nigeria. *Journal of Agriculture and Veterinary Science* Vol. 6 No. 2 PP 1 – 8.
- Obinne CPO, (1991) Adoption of improved cassava production technologies by small scale farmers in Bendel State. *Journal of agricultural science technologies* 1(1):12-15
- Omale, J.A. (2004), *The Igalas: How Many?* Produced by I.C.O.A. ACTION AND PUBLICTY COMMITTEE ON CENSUS 2005. Published by Bencaz Printers Ankpa, Nigeria.
- Onweremadu, E.U, and Mathew-Njoku, E.C. (2007) Adoption levels and sources of soil management practices in low input agriculture. *Nature and science* 207:5:1.
- Onuche, U. Opaluwa, H.I. and Edoke, M.H. (2014), Ill-Health and Agricultural Production: Evidence from Kogi State of Nigeria. *African Journal of Food, Agricultural*

Nutrition and Development. 14(1):  
8488-8503.

Orebiyi, J.S., Eze, C.C., Henry-Ukoha, A., Akubude, F.C., and Ibitoye, S.J. (2011). Demand for institutional credit from NACRDB by small scale farmers in Imo State, Nigeria. *International Journal of Agricultural Science, Research and Technology*. 1(2). 83-87

Orisakwe, L. and Agomuo, F.O. (2011): "Adoption of Improved Agro-forestry Technologies among Contact Farmers in Imo State, Nigeria" Vol. 2, No. 1, pp. 1-9

Salau *et al*; (2010) cited in Bashir, et al. (2018). "Adoption of Cowpea Production Technologies Among Farmers in Taraba State, Nigeria." *IOSR Journal of Agriculture and Veterinary Science (IOSR-JAVS)* 11.3 (2018): 37-46.

Sani, A., Abubakar, B.Z, Yakubu, D.H., Atala, T.K. and Abubakar, L. (2014) *Socio-economic factors influencing adoption of dual-purpose cowpea production technologies in Bichi Local Government Area of Kano State, Nigeria*. *Asia Journal of Agricultural Extension Economics and Sociology*. PP 258-273.

Tijjani, A. R. Nabinta, R. T. Muntaka, M. (2015) *Adoption of innovative cowpea production practices in a rural area of Katsina State, Nigeria*. *Journal of Agricultural and Crop Research* Vol. 3(4), pp. 53-58, June 2015 ISSN: 2384-731X



## GROWTH RESPONSE OF FOUR NEMATOPHAGOUS FUNGI IN DIFFERENT GRAIN AND BRAN MEDIA

Bello<sup>1\*</sup>, L. Y., M. T. Salaudeen<sup>1</sup>, P. S. Chindo<sup>2</sup>, N. O. Agbeni<sup>2</sup>, M. D. Alegbejo<sup>2</sup>, A. S. Paiko<sup>3</sup>

<sup>1</sup>. Department of Crop Production, School of Agriculture and Agricultural Technology, Federal University of Technology, Minna, Niger State

<sup>2</sup>. Department of Crop Protection, Faculty of Agriculture, Ahmadu Bello University, Zaria, Kaduna State

<sup>3</sup>. Department of Pest management Technology, College of Agriculture, Mokwa, Niger State

\*Corresponding Author's E-mail: [b.yunusa@futminna.edu.ng](mailto:b.yunusa@futminna.edu.ng), GSM: 08037035864

### ABSTRACT

*Nematophagous fungi such as Arthrobotrys, Dactylaria, Dactylella and Monacrosporium species were isolated and identified from leaf debris of mango, cashew and orange based on their morphological characteristics in Zaria, Kaduna State, Nigeria. Four different cereal grain and bran media were screened to determine their ability to support sporulation and growth of the fungi. After 21 days of inoculation, there was complete colonization of the Petri dishes diameter, all the fungi spreading at the rate of about 0.26 to 0.46 cm per day. Arthrobotrys and Monacrosporium species in grain (sorghum) medium produced about  $(17.54 \times 10^4)$  spores per milliliter, respectively. The four isolated fungi genera had good mycelia growth in wheat, millet, sorghum and rice grain media, while Arthrobotrys and Monacrosporium spread better in sorghum medium. Dactylella and Monacrosporium species gave the highest spore count in sorghum and millet bran. The experiments revealed that all the four isolated nematophagous fungi can be culture in these grain media for mass production of these fungi at minimum cost.*

**KEYWORDS:** Nematophagous fungi, leaf debris, media and spore count

### INTRODUCTION

Predatory fungi are recognized as having potential for the biological control of plant parasitic nematodes. These fungi produce ring-shaped structures that maybe constrictors or non-constrictors, threedimensional adhesive networks along the length of the hyphae, responsible for immobilization and penetration of the nematode cuticle (Barron, 1977, Nordbring-Hertz, 2004). The nematophagous fungi have a significant contact with their prey especially nematodes in their vicinity and thus, can constantly capture and destroy them (Li *et al.*, 2000; Liu and Zhang, 2003; Dong *et al.*, 2004; Mo *et al.*, 2005; Li *et al.*, 2005; Bello *et al.*, 2012). There are various ways for soil-borne fungi to suppress nematode multiplication, which are either direct or indirect manner. In direct mechanism, the fungi feed on nematodes, while the indirect manner fungi kill nematodes by mycotoxin (Barron and Throne, 1987), through the destruction of the feeding sites of sedentary nematodes in root (Glawe and Stiles, 1989). Some bacteria and fungi produce metabolic by products which interfere with nematode behaviour, and many soil organisms parasitize or prey on

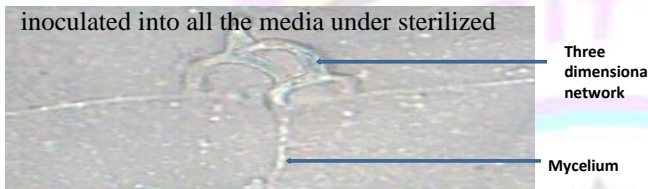
nematodes. The fungi used for biocontrol of nematodes include predaceous fungi and endoparasites fungi e.g. *Dactylella*, *Arthrobotrys*, *Paecilomyces lilacinus*, *Verticillium chlamydosporium* etc. (Goswami and Uma, 1995).

Knowledge aspect such as mycelia sporulation capacity which may lead to mass or biomass production of spores is necessary to determine the potential of nematophagous fungi as efficient agents in programmes of biological control. Maintenance of cultures for prolonged periods in a suitable medium may be obtained by means of different culture medium that may depend on different characteristics of the fungal species, availability of the facilities for carrying out the method(s) and as well as the economic costs (Bello *et al.*, 2012). Management of plant parasitic nematodes with high doses of some nematicides did not receive much popularity and have been withdrawn from world market due to their harmful effects on the environment. In view of these, researchers tend to diversify and look inward into developing alternative control measure such as biopesticides (Nordbring-Hertz, 2004). Biological control which is an alternative to nematicides has been gaining ground and becoming important in

recent years, viz: using natural enemies within the same rhizosphere to control nematodes. One of such natural enemies of nematodes that their population is abundant in all types of soils is the predacious fungi (Bello *et al.*, 2012). However, these fungi produce study to evaluate different grain and bran growth media for sporulation of some isolated predacious fungi from decayed plant debris in Zaria, Nigeria.

ring-shaped that maybe constrictors or nonconstrictors (Barron, 1977). Plates 1-5 are some constricting organs and nematodes captured from our previous work. This formed the basis of the research

conical flask was allowed some few minutes to cool; the medium was dispensed gently into sterilized 9 cm Petri-dishes to covered about 2/3<sup>rd</sup> area of each plate and inoculated with 5 mm disc of 15 days old culture of the isolated predacious fungi. Each fungus



condition and replicated four times. The plates were randomly arranged on the laboratory bench and radial growth measured at 3 days interval for 21 days. Four different nematophagous fungi isolated were inoculated into each medium and replicated four

times to have a total of 80 Petri dishes in a complete **Plate 1: A typical three dimensional network of *Arthrobotrys* species** randomize design (CRD). After 21 days, each Petridish flooded with 50 ml sterile water and agitated for separation of spore. Spores from each Petri-dish were collected into a separate beaker. All the collected spores were counted using Neubauer chamber



hemocytometer and the number of spore per ml was analyzed and calculated as follows.

**Spore count of the isolated fungi using Neubauer improved haemocytometer.** After 21 days of incubation, each Petri dish was flooded with 50 ml distilled water, agitated for separation of spore using an electric mixer for about 60 seconds. The



**Plate 3: Nematophagous fungus , bunch of conidia, detached conidium and nematode captured at both ends**



## METHODOLOGY

The radial growth and sporulation of the isolated nematophagous fungi (*Arthrobotrys* sp., *Dactylaria* sp., *Dactylella* sp., and *Monacrosporium* spp. were studied on Bran and grain of Wheat (*Triticum aestivum*), Rice (*Oryza sativa*), Sorghum (*Sorghum bicolor*), and Millet (*Pennisetum glaucum* (L)). The experiment was carried out in the Department of Crop Protection, Faculty of Agriculture/Institute for Agricultural Research, Ahmadu Bello University Samaru, Zaria. Each bran and grain media contain 20g bran, 20 g agar and 1000 ml of distilled water, autoclaved for 15 minutes at 15 psi pressure at 121°C in a separate labelled conical flask. After 15 mins, the homogenized mixture was filtered through a Muslin cloth and the filtrates made up to 50 ml. All the filtrate spores were collected separately from each Petri dish for each isolated fungus. The spores were counted using Neubauer haemocytometer and the number of spores per ml of water was calculated as shown below.

- (a) All the total spores in the four corner squares were counted
- (b) The spore count were calculated using the equation: spores/ml = (n) x 10<sup>4</sup> where: n = the average cell count per square of the four corner squares counted and those outside the four corner squares were neglected.

Example: if the calculated average (n) of spores in the four 1 mm corner squares of the haemocytometer is 70: Cell/ml = (n) x 10<sup>4</sup> or spores/ml = 70 x

10,000 = 700,000 spores/ml

In 50ml = 50 x 70 x 10,000 = 35 x 10<sup>6</sup> spores  
(Janice, 2010)

## RESULTS AND DISCUSSION

### Radial growth of *Arthrobotrys*, *Dactylella*, *Dactylaria* and *Monacrosporium* species in different grain media at three days intervals for a period of twenty days of incubation

Radial growth of the isolated nematophagous fungi was carried out in different whole grain media of millet, rice, sorghum and wheat. The mycelia growth were observed and recorded for a period of 21 days. The *Arthrobotrys* sp. responded to radial growth in all the media in which there was no significant difference between rice and wheat grain media at each interval for a period of 21 days of incubation. Similar

observation was recorded for millet and sorghum grain media except at day 3 (3.98, 4.99) in which significant difference was recorded respectively. Millet and sorghum grain media responded to radial growth of *Arthrobotrys* sp. (Fig. I) than rice and wheat grain media, all the Petri dishes were covered with mycelia growth and there was a significant difference between millet and sorghum (9.00, 9.00), rice and wheat (7.91, 8.04) at 18 days of incubation respectively. All the media were completely covered after 21 days of incubation.

### Radial growth of *Dactylella* species in different grain media at three days intervals for a period of twenty one days of incubation.

After 3 days of incubation, response of *Dactylella* sp in radial growth was more than *Arthrobotrys* sp. (Fig. 11) and there was no significant difference between millet and wheat grain media (4.58, 4.04), but high significant differences were recorded between rice and sorghum grain media; similar observation was recorded after 6 days of incubation. There was a significant difference between all the media after 9 days of incubation with sorghum grain (8.99) recording the highest radial growth and the least in wheat grain (6.40). Between 12 and 21 days of incubation of this fungus, the mycelia growth increased, the Petri dishes were completely covered and there was no significant difference between the grain media at 15 and 21 days of incubation.

### Radial growth of *Dactylaria* species in different grain media at three days intervals for a period of twenty one days of incubation.

*Dactylaria* sp responded faster in radial growth than all the isolated nematophagous fungi in these grain media (Fig.III) after 3 days of incubation with no significant difference between rice, sorghum and wheat grain media. However, after 6 days of incubation of this fungus, significant difference was recorded between millet, rice and sorghum as well as between millet, wheat and sorghum respectively, but no significant difference between rice and wheat grain media (8.23, 7.95). After 9 days of incubation, there was no significant difference ( $P \leq 0.05$ ) between millet, rice and wheat grain with the exception of sorghum grain media (8.38) in which significant difference was recorded. All the grain media responded to mycelia growth of this fungus, Petri dishes were completely covered between 9 and 21 days of incubation except



sorghum grain media in which 8.38 cm was recorded at 9 days of sporulation.

**Radial growth of *Monacrosporium* species in different grain media at three days intervals for a period of twenty one days of incubation.** Significant difference was recorded between all the grain media ( $P \leq 0.05$ ) after 3, 6, and 9 days of incubation of *Monacrosporium* sp. with sorghum grain media having the highest radial growth of (6.83, 7.91, 8.95) and least in millet grain media of (4.75, 5.98, 7.09) respectively. After 12 days of incubation, there was no significant difference between sorghum and wheat grain media; however significant difference was recorded between millet and rice grain media. Complete radial growth was recorded for this fungus between 15 and 21 days and there was no significant difference between all the grain media after 21 days of incubation (Fig. IV).

**Sporulation of the isolated nematophagous fungi in different grain media after 21 days of incubation.**

The spore count of the isolated nematophagous fungi was carried out after 21 days radial growth in all the grain media, for *Arthrobotrys*, *Dactylaria* and *Dactylella* species, significant difference was recorded in the numbers of spores produced after 21 days of incubation in all the grain media (Figure V), however, there was no significant difference between millet and sorghum media (16.63, 16.53) in the numbers of spores produced for *Monacrosporium* sp.

**Mycelia radial Growth of *Arthrobotrys*, *Dactylaria*, *Dactylella* and *Monacrosporium* species in Different Bran Media at three days Intervals for a Period of Twenty one days of Incubation.**

All the bran media tested supported the growth of the isolated nematophagous fungi after 21 days of incubation. The radial growth of *Arthrobotrys* spp.

increased significantly ( $P \leq 0.05$ ) with increase in incubation period up to 9 days in all the media except rice bran in which there was no significant increase. Rice bran medium supported mycelia radial growth best when compared with others after 9 days of incubation (Table 1).

Significant increase was observed in mycelia radial growth of *Dactylaria* spp. after 3 days of incubation

in rice bran medium when compared with others. Rice bran medium was observed to be the best in mycelia radial growth of *Dactylaria* spp. There was no significant increase in mycelia radial growth of this nematophagous fungus after 12 days of incubation except in millet bran in which slight mycelia radial growth was observed from 8.46 cm to 9.00 cm. In all the media tested, there was no significant increase in mycelia radial growth of *Dactylaria* sp. between 15 – 21 days after incubation (Table 2).

Significant increase was observed in mycelia radial growth of *Dactylella* spp. between 3 - 9 days of incubation in all the bran media in which millet bran was the best at 9 days (8.56 cm) after incubation and the least mycelia radial growth was observed in sorghum bran medium throughout the period of incubation (Table 3). Significant increase in mycelia radial growth of *Dactylella* spp. was observed between 12 – 18 days in all the media, except in millet and wheat bran media in which there was no significant increase in mycelia radial growth after 18 days of incubation. There was no significant increase in mycelia radial growth of *Dactylella* spp. in all the tested media after 21 days of incubation (Table 3). All the bran media tested supported the growth of *Monacrosporium* spp. (Table 4). Mycelia radial growth of this fungus increase significantly ( $P \leq 0.05$ ) in rice bran media with increased in incubation period up to 6 days of incubation. There was no further increase of mycelia radial growth for *Monacrosporium* sp. between 9 – 21 days of incubation in rice bran medium. Rice bran medium supported mycelia radial growth best after 9 days of incubation when compared with other media. Similarly, as observed in *Arthrobotrys* (Table 1) and *Dactylaria* (Table 2) species in rice medium, there was no significant increase in mycelia radial growth of *Monacrosporium* spp. between 18 – 21 days of incubation (Table 4). It was observed that, rice bran medium was the best medium that supported mycelia radial growth of *Arthrobotrys*, *Dactylaria* and *Monacrosporium* species, while *Dactylella* spp. (Table 3) gave the best result in millet bran medium after 12 days of incubation.

**Sporulation of Four Nematophagous Fungi to Different Bran Media**

All the bran media significantly produced high number of spores after 21 days of culture. Rice bran medium was the best for *Arthrobotrys* spp. and millet bran medium was the best for *Dactylella* and

*Monacrosporium* species when compared with others. However, there was no significant increase in the number of spore produced for *Dactylaria* spp. in millet and sorghum bran media, but the highest number of spore produced was obtained in sorghum bran medium after 21 days of culturing (Fig. VI).

growth of *Arthrobotrys* and *Dactylella* species completely covered all the Petri dishes of these bran media between 6 and 9 days, and between 9 and 12 days respectively.

### CONCLUSION AND RECOMMENDATIONS

All the bran media supported the four fungi radial growth after 21 days of incubation; however mycelia growth spread faster in all the media for *Arthrobotrys* than *Dactylella* species. Tables 1 & 2 also indicated that *Arthrobotrys* and *Dactylella* species attained full mycelia growth at 12 and 21 days of incubation respectively. This observation is in agreement with (Mo and Zhang, 2005) in which it was reported that *Arthrobotrys yunnanensis* attained 6 cm diameter radial growth in corn meal agar medium in 5 days at 28°C and mycelia spreading at 0.5 cm per 24 hours. Tables 2 indicated that rate of spread of *Dactylella* sp is slow compared to *Arthrobotrys* sp (Table 1). One of the main aims of going into the use of biocontrol to control nematodes is to have cheap means of producing the control agent's materials for the end users, the farmers. For addition of the nematophagous fungi in nematode infested soil, there is an urgent need for quick and mass production of these fungi in suitable locally available substrates that are cheap all over the country. In all the cereals tested for mycelia radial growth and sporulation of the four isolated fungi, complete growth was recorded in all the grain media prepared from rice, sorghum, wheat and millet between 15 and 21 days of incubation, however. *Dactylaria* spp. grew better in millet and rice grain media at 6 and 9 days, respectively. In all the media, average radial growth of the mycelia spread at the rate of about 0.26 to 0.46 cm per day was achieved. In view of these findings, for in-vitro mass sporulation of *Arthrobotrys*, *Dactylella*, *Dactylaria* and *Monacrosporium* species, rice and millet bran are recommended respectively. This is because; mycelia

**Table 1: Mycelia Radial Growth of *Arthrobotrys* species in Different Bran Media.**

Treatment	Radial growth (cm) of <i>Arthrobotrys</i> species (days)						
	3	6	9	12	15	18	21
Media	4.74 <sup>b</sup>	6.04 <sup>b</sup>	7.66 <sup>b</sup>	9.00	9.00	9.00	
Millet bran							9.00

Rice bran	4.13 <sup>b</sup>	8.06 <sup>a</sup>	9.00 <sup>a</sup>	9.00	9.00	9.00	9.00
Sorghum bran	5.60 <sup>a</sup>	6.86 <sup>b</sup>	8.15 <sup>b</sup>	9.00	9.00	9.00	9.00
Wheat bran							
LSD	5.76 <sup>a</sup>	6.90 <sup>a</sup>	8.14 <sup>b</sup>	9.00	9.00	9.00	9.00
LSD	0.798	0.878	0.464	NS	NS	NS	NS

Means within a column followed by the same letter(s) are not significantly different at 5% level of probability \*

NS = Not significant

**Table 2: Mycelia Radial Growth of *Dactylaria* species in Different Bran Media.**

Radial growth (cm) of *Dactylaria* species (days)

Treatment	3	6	9	12	15	18	21
Media							
Millet bran	4.23 <sup>c</sup>	5.38 <sup>d</sup>	7.24 <sup>c</sup>	8.46 <sup>b</sup>	9.00	9.00	9.00
Rice bran	7.25 <sup>a</sup>	9.00 <sup>a</sup>	9.00 <sup>a</sup>	9.00 <sup>a</sup>	9.00	9.00	9.00
Sorghum bran	4.81 <sup>b</sup>	6.09 <sup>c</sup>	7.49 <sup>b</sup>	9.00 <sup>a</sup>	9.00	9.00	9.00
Wheat bran	6.90 <sup>a</sup>	7.85 <sup>b</sup>	9.00 <sup>a</sup>	9.00 <sup>a</sup>	9.00	9.00	9.00
LSD	0.325	0.257	0.104	0.118	NS	NS	NS

Means within a column followed by the same letter(s) are not significantly different at 5% level of probability \*

NS = Not significant

**Table 3: Mycelia Radial Growth of *Dactylella* species in Different Bran Media.**

Radial growth (cm) of *Dactylella* species (days)

Treatment	3	6	9	12	15	18	21
Media							
Millet bran	6.01 <sup>a</sup>	7.13 <sup>a</sup>	8.56 <sup>d</sup>	9.00 <sup>a</sup>	9.00 <sup>a</sup>	9.00 <sup>a</sup>	9.00
Rice bran	4.51 <sup>b</sup>	5.30 <sup>b</sup>	6.41 <sup>b</sup>	7.36 <sup>b</sup>	8.48 <sup>b</sup>	8.93 <sup>a</sup>	9.00



Sorghum bran	1.01 <sup>d</sup>	1.96 <sup>d</sup>	4.80 <sup>d</sup>	6.11 <sup>d</sup>	7.48 <sup>c</sup>	8.84 <sup>a</sup>	9.00
Wheat bran	2.98 <sup>c</sup>	4.20 <sup>c</sup>	5.54 <sup>c</sup>	6.75 <sup>c</sup>	8.06 <sup>b</sup>	9.00	9.00
LSD	0.398	0.403	0.427	0.491	0.415	0.130	NS

Means within a column followed by the same letter(s) are not significantly different at 5% level of probability \*

NS = Not significant

**Table 4: Mycelia Radial Growth of *Monacrosporium* species in Different Bran Media.**

Treatment Media	Radial growth (cm) of <i>Monacrosporium</i> species (days)						
	3	6	9	12	15	18	21
Millet bran	4.58 <sup>a</sup>	5.96 <sup>a</sup>	7.59 <sup>b</sup>	9.00 <sup>a</sup>	9.00 <sup>a</sup>	9.00	9.00
Rice bran	4.48 <sup>a</sup>	7.01 <sup>a</sup>	9.00 <sup>a</sup>	9.00 <sup>a</sup>	9.00 <sup>a</sup>	9.00	9.00
Sorghum bran	3.65 <sup>b</sup>	5.08 <sup>b</sup>	6.46 <sup>c</sup>	7.61 <sup>b</sup>	8.68 <sup>b</sup>	9.00	9.00
Wheat bran	5.21 <sup>a</sup>	6.61 <sup>a</sup>	7.78 <sup>b</sup>	9.00 <sup>a</sup>	9.00 <sup>a</sup>	9.00	9.00
LSD	0.617	0.817	0.578	0.327	0.215	NS	NS

Means within a column followed by the same letter(s) are not significantly different at 5% level of probability \*

NS = Not significant

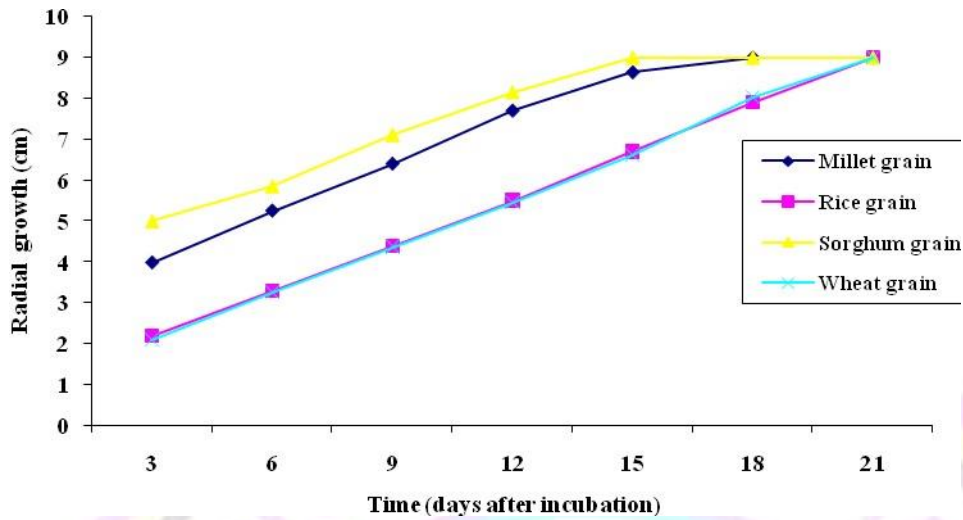


Fig. I: Radial growth of *Arthrobotrys* species in different grain media at three days intervals for a period of twenty one days of incubation

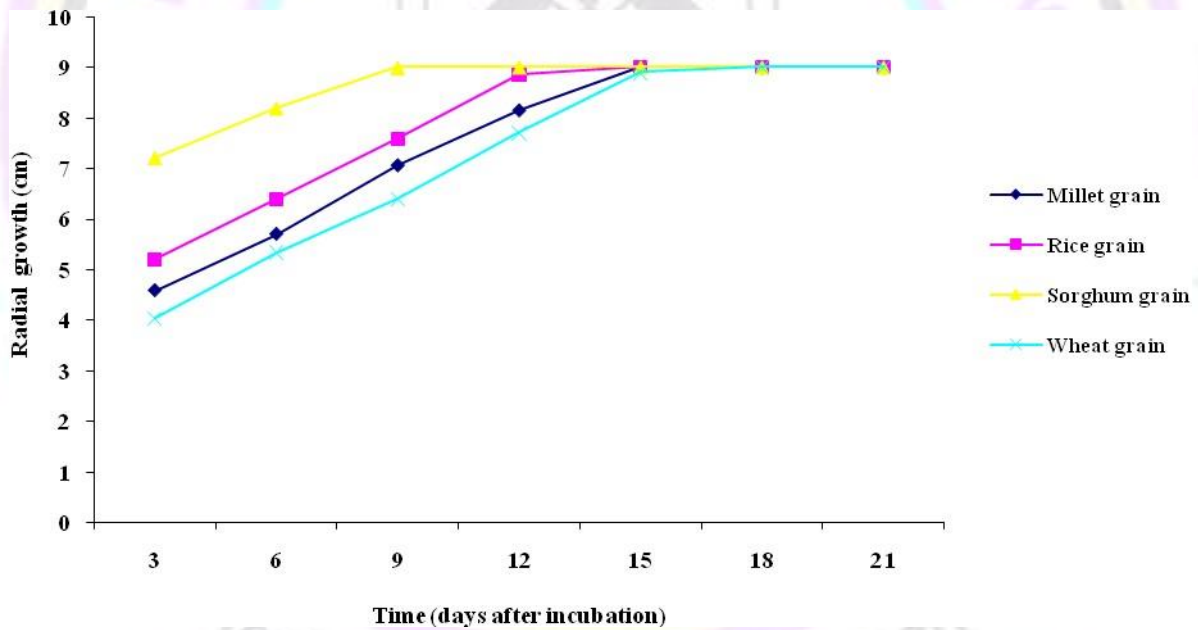


Fig. II: Radial growth of *Dactylella* species in different grain media at three days intervals for a period of twenty one days of incubation

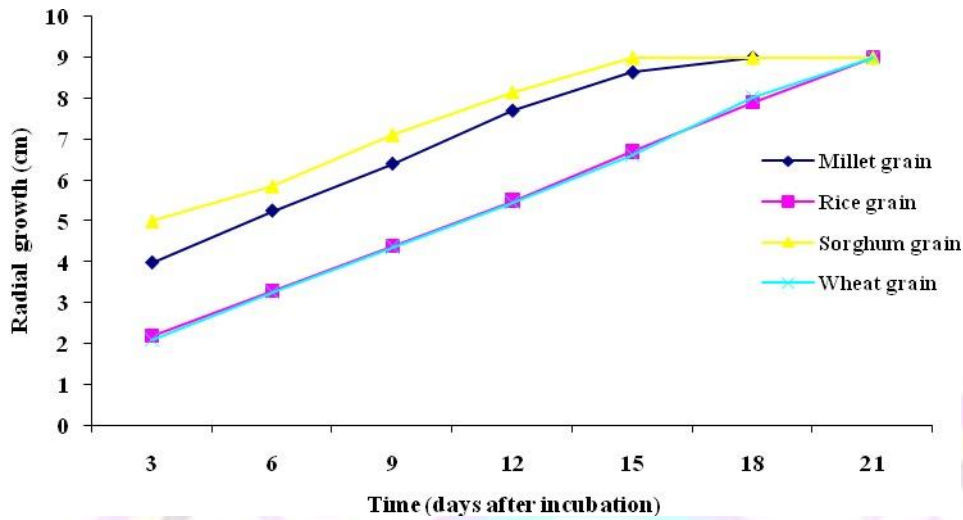


Fig. III: Radial growth of *Dactylaria* species in different grain media at three days intervals for a period of twenty one days of incubation

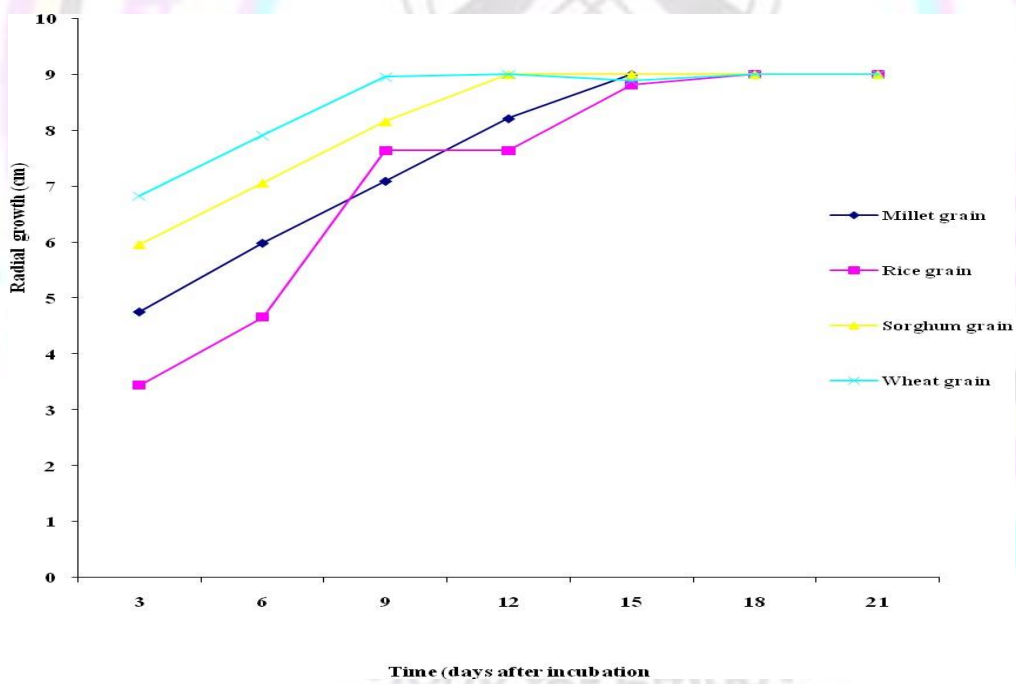
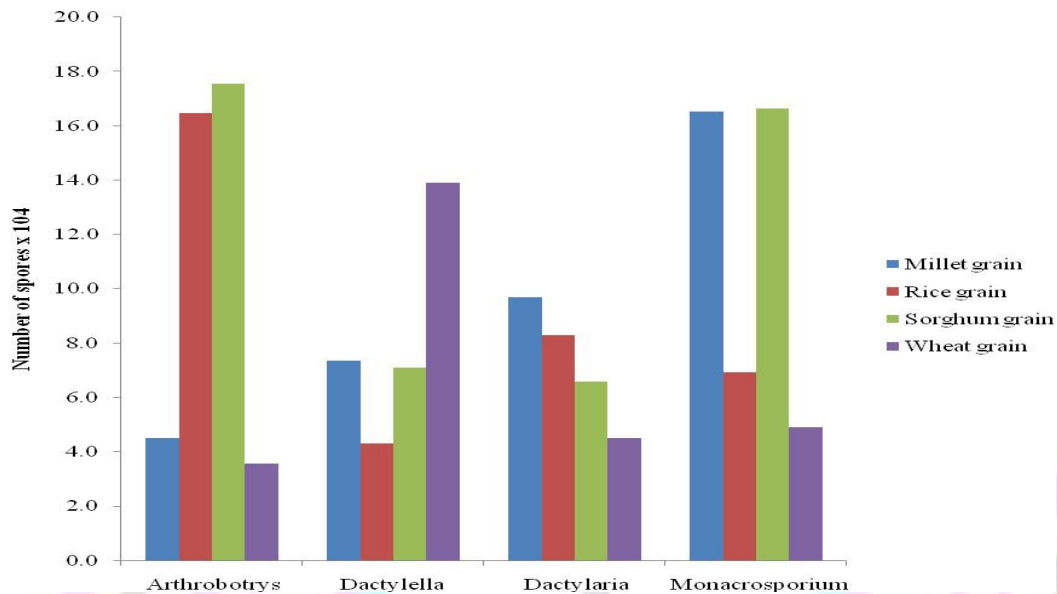
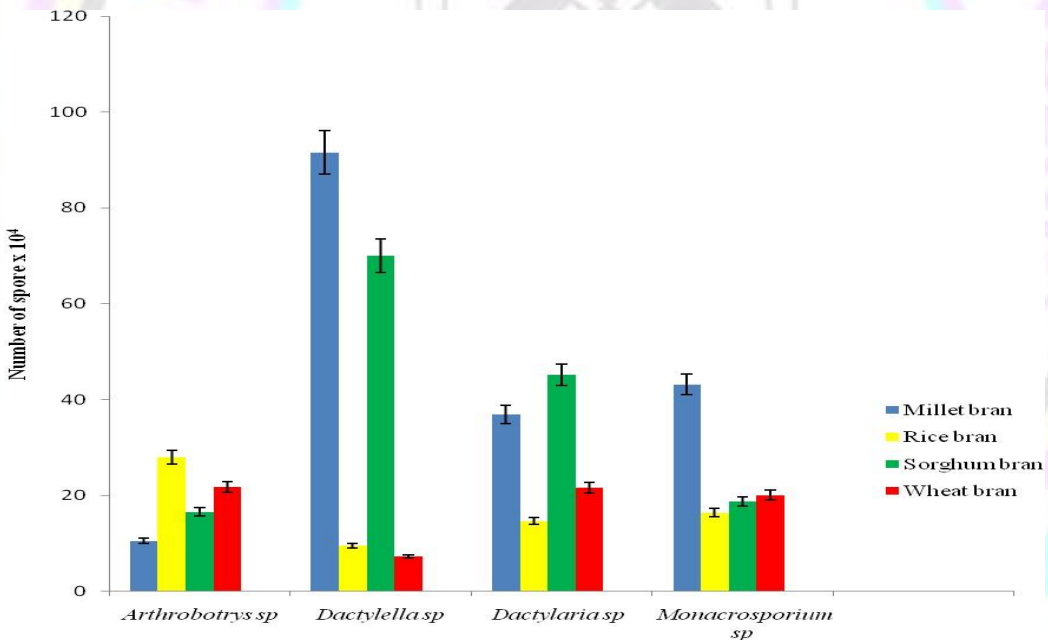


Fig. IV: Radial growth of *Monacrosporium* species in different grain media at three days intervals for a period of twenty one days of incubation





**Fig. V: Sporulation of the isolated nematophagous fungi in different grain media after 21 days of incubation**



**Fig. VI: Sporulation of Four Nematophagous fungi in Different Bran Media**

## REFERENCES

Barron, G. L. (1977). The nematode-destroying fungi. Canadian Biological Publications, Guelph, 140p

Barron, G. L. and Thorne, R. G. (1987). Destruction of nematodes by species of

Pleurotus. *Canadian Journal of Botany* 65: 774-778

Bello, L.Y., Chindo, P.S., Agbenin, N.O and Alegbejo, M.D (2012). Isolation of nematophagous fungi from decayed debris of

- some orchard plants around Zaria, Nigeria. *Nigerian Journal of Plant Protection* (NJPP). 26: 116-125.
- Bello, L.Y., Chindo, P.S., Agbenin, N.O and Alegbejo, M.D (2012). *In-vitro* evaluation of different growth media for sporulation of some nematophagous fungi in Zaria, Nigeria. *Nigerian Journal of Plant Protection* (NJPP). 26: (142-146)
- Dong, J.Y., Zhao, Z.X., Cai, L., Liu, S.Q., Zhang, H.R., Duan, M. And Zhang, K.Q. (2004). Nematicidal effect of fresh water fungi cultures against the pine-wood nematode; *Bursaphelenchus xylophilus*. *Fungi Diversity* 15: 125-135.
- Goswami, B.K., and Uma Rao.(1995). Fungi for biocontrol of plant parasitic nematodes- Nematode pest management an appraisal of Eco-friendly approaches-chapter 6.p.50-52.
- Glawe, D. A., and C. M. Stiles. 1989. Colonization of soybean roots by fungi isolated from cysts of *Heterodera glycines*. *Mycologia* 81: 797-799.
- Janice, [Henderson@kirkhoustrust.org](mailto:Henderson@kirkhoustrust.org) 2010. The Neubauer Improved Haemocytometer.
- Li, T. F., Zhang, K. Q., Liu, X. Z (2000) Taxonomy of Nematophagous Fungi (Chinese Scientific and Technological Publications, Beijing).
- Li, Y., Hyde, K.D., Jeewon, R., Cai, L., Vijaykrishna, D. And Zhang, K.Q. (2005). Phylogenetics and evolution of nematode-trapping fungi (*Orbiliiales*) estimated from nuclear and protein coding genes. *Mycologia* 97:1034- 1046.
- Liu, X.F. and Zhang, K.Q. (2003). *Dactylella Shizishanna* sp. nov., from Shizu mountain, China; *Fungal Diversity* 14: 103-107.
- Mo, M.H., Huang, X.W., Zhou, W., Huang, Y., Hao, Y.E and Zhang, K.Q. (2005). *Arthrobotrys yunnanensis* sp. nov., the fourth anamorph of *Orbilina auricolor*. *Fungi Diversity* 18: 107-115.
- Nordbring-Hertz, B (2004). Morphogenesis in the nematode-trapping fungus *Arthrobotrys oligosporal* – an extensive plasticity of infection structures. *Mycologist* 18:125-133.

# FISHER FOLKS PERCEPTION OF THE EFFECT OF CLIMATE CHANGE ON INLAND FISHERIES IN NIGER STATE” NIGERIA.

<sup>1</sup>Alhassan Isah Loko <sup>2</sup>Umar, Isah Sheshi., <sup>2</sup>Safiya Jibrin., <sup>2</sup>Muhammed, Ibrahim.,  
<sup>3</sup>Mohammed, Usman., <sup>4</sup>Usman, Ndagi Sonlawu., <sup>5</sup>Abubakar, Umar.

<sup>1</sup>Dept of Agric. extension & Management, Niger State College of Agriculture, Mokwa}

<sup>2</sup>Dept. of Agric. Extension, and Rural Development, Federal University of Technology, Minna

<sup>3</sup>Niger State Ministry of Agriculture and Rural Development, Minna.

<sup>4</sup>Government College Bida, General Science Department, Niger State

<sup>5</sup>Ibrahim Badamasi Babangida University, Lapai, Niger State

Phone no. 08034509866. E Mail: isah.loko@yahoo.com

## ABSTRACT

The general objective of the research was to analysed “the Fisher Folks Perception of the Effect of Climate Change on Inland Water Fisheries in Niger State” Nigeria. Multi-stage sampling procedure was used for the study with a total of 195 fishermen sampled. Descriptive and inferential statistics were used for the analysis. The result reveals that fishermen were within the age of between 41 and 50. Fishing activities in the study area were dominated by the male (76.9%). fishermen with secondary certificate were 42.6%. Greater proportion (66.7%), of the fishermen belong to fish farmer’s cooperative. Majority (56.4%) received extension message through the individual methods. Similarly, majority (94.4%) had no access to credit. Most of the fish farmers (73.3%) earn income of between N100, 000 – 300,000. Human factor such as bush burning (84.6%), deforestation (87.2%), over grazing (76.9%) contributed to climate change. Fishermen noticed droughts, desiccation and dryness (95.9%), rise in temperature (94.9%), and reduce water quality (90.3%). Measure adapted by fisher folks to mitigate against climate change effects were diversification or intensification of fishing production (85.6%), changes in fishing methods, types and sizes of gears used (90.8%). lack of fund (91.3%), high cost of fishing equipment (94.9), were problems in the study areas. Education (4.838%), income (-4.262), mitigation strategies (4.899%) and cooperative membership (5.041%) were significantly related to perceived effect of climate change at 1% level of probability. Furthermore, Furthermore, perceived effect of climate (88.277) and mitigation strategies (124.205) were significant at 1% probability level. Fish farmer should be taught by extension agents the mitigation measures against flooding, intense wind, storms and hurricane such as planting of trees, cover crops etc.

**Keywords:** Fisher Folks, Climate Change, Inland Fisheries

## INTRODUCTION

Fish is highly nutritious, so even small quantities can improve people’s diets, Food and Agriculture Organization (FAO, 2007a). Fish can provide vital nutrients absent in typical starchy staples which dominate poor people’s diets (FAO, 2005). Fish provides about 20 percent of animal protein intake in 127 developing countries and this can reach 90 percent in Small Island Developing States (SIDS) or coastal areas (FAO, 2005). Although aquaculture has been contributing an increasingly significant proportion of fish over recent decades, approximately two-thirds of fish are still caught in capture fisheries. Fisheries can also contribute indirectly to food security by providing revenue for food-deficient countries to purchase food, fish exports from low-income (FAO, 2005).

Climate change is a significant and lasting change in the statistical distribution of weather patterns over periods ranging from decades to millions of years. It

may be a change in average weather conditions, climate change is caused by factors that include oceanic process (such as oceanic circulation), variation in solar radiation received by the earths tectonic plates and volcanic eruptions and human induced alterations of the natural worlds, these effects are currently causing global warming and climate change is often use to describe human specific impacts by Intergovernmental Panel on Climate Change (IPCC, 2007). Climate change is modifying fish distribution and productivity of fresh water species. This has effect on the sustainability of fisheries and aquaculture on the livelihoods of communities that depend on fisheries. The effects of changing rainfall patterns and water have impact on fresh water fisheries (Hall and Stuntz, 2007). Several international agencies including the World Bank and the Food and Agriculture Organization (FAO) have programmes to help



countries and communities adapts to climate change (World Development Report, 2010).

**Aim and Objectives of the study**

The general objective of the study was to examine the fisher folk’s perception of the effect of climate change on inland water fisheries in the study area. The specific Objective of the study were to:

- i. describe the socio-economic characteristic of the fisher folks in the study area;
- ii. describe the extent to which fisher folks perceived the effect of climate change on inland fisheries;
- iii. identify the measures adopted by the fisher folks to mitigate against climate change effect;
- iv. determine the influence of socio – economic characteristics on the perception of fisher folks on the effect of climate change, and
- v. identify the constraints to adaptation and mitigation measures of climate change by inland fisher folks.

**Hypotheses of the study**

- i. There is no significant relationship between fisher folk’s perception of the effect of climate change on inland fisheries and measures adopted to mitigate climate change and its effect in the study area;

**Methodology**

Niger State is divided into 3 agricultural zones namely: Zone 1, Zone 11 and Zone 111.

Multi-stage sampling techniques were used for the study. The first stage involves purposive selection of three Local Government Areas (Wushishi, Mokwa and Shiroro) for the study because of prior knowledge of higher concentration of fishing activities in the study area. The second stage involves the use of simple random sampling technique to select 3 fishing villages from each selected Local Government Area. The third stage involved the use of Yamane formula equation for appropriate sample size determination as reported by Eboh (2009) as shown in equation 1

$$N = \frac{nN}{1 + n(e)^2}$$

..... 1

Where n is the sample size, N is the population size and e is the level of precision which is 0.05% , 1 = Constant.

**Data Collection**

The primary data was collected by the researcher through interview schedule and was used for those that

cannot read and right, while structured questionnaire was used for those that can read and right.

**RESULTS AND**

**DISCUSSION**

**Socio – economic characteristics of fishermen**

**Age:** The result of Table 4.1 showed that age range of 41 – 50 was 35.9%, 51years and above had the highest percentage of 41.5%, Elder fisher folks may have more experience on climate change effect on inland fisheries because of long time experience they had in fishing activities than the younger one. This agrees with the findings of Rahman and Umar (2009) whose finding showed that majority of fisher folks in Niger State that perceived the effect of climate change on inland fisheries fall within 41 – 50 years of age.

**Sex:** Sex distribution of the fishermen showed that majority of (76.9%) were male while (23.1%) were female, this implies that most of fishing activities in the study area were dominated by the male folks, perhaps too strenuous for the female folks to fully participate. This result disagrees with ascertainment by Adewale, *et al.*, (2003) that gender is no barrier to active involvement in fishing activities.

**Household size of the fishermen:** The result in Table 4.1 indicated that 43.1% of the respondents had 6 – 10 household size while 40.0% had house hold size of less than 6. The implication is that most of the fishermen with large house hold size would perceive more on effect of climate change and adopt mitigation strategies on effect of climate change than small household size.

**Level of education of the fishermen:** The result in Table 4.1 revealed that 42.6% of the fishermen had secondary certificates, this would provide knowledge and skills to perceived the effect of climate change than the primary certificates holders (23.2%) in the study area, implying that there is high prospect of adopting new technology.

**Year of fishing experience:** The result in Table 4.1 showed that 31.8% of the fish farmer had fishing experience of 15 years and above followed by 28.2% & 26.2% of the respondents who had 6 – 10 years and 11 – 15 years of fishing experience respectively. The more the number of years of fishing experience the more likely the respondents would have perceived and experienced the effects of climate change in the study area.

**Major occupation of the fishermen:** The result in Table 4.1 showed that the majority (52.8%) of the ishermen had fishing as major occupations while 37.4% engaged in crop production and 9.7% of fishermen were civil servants. This implies that fishermen who engaged in fishing on full time

**Table 4.1: Distribution of respondents according to socio – economic characteristics**

Age (years)	Frequency	Percentage (%)
20 – 30	4	2.1
31 – 40	40	20.5
41- 50	70	35.9
51 and above	81	41.5
<b>Sex</b>		
Male	150	76.9
Female	45	23.1
<b>Household size</b>		
< 6 people	80	40.0
6 – 10 people	84	43.1
<b>Socio-economic characteristics continue</b>		
11– 13 people	17	8.7
> 13 people	14	7.2
<b>Educational level</b>		
Primary	46	3.6
Secondary	83	42.6
Tertiary	9	4.6
Quranic	57	29.2
<b>Years spent in school</b>		
< 6 years	28	14.4
6 – 10	75	38.5
11– 15	89	45.6
>15 years	3	1.5
<b>Years of fishing experience</b>		
< 6 years	27	13.8
6 – 10 years	51	26.2
11 – 15 years	55	28.2
>15 years	62	31.8
<b>Major occupation</b>		
Crop production	73	37.4
Fishing	103	52.8
Civil servant	19	9.7
<b>Total</b>	<b>195</b>	<b>100</b>

Source: Field Survey, 2015

**Distribution of fish farmers according to their cooperative membership, extension methods contact, labour, access to credit, income and output obtained from fishing activities.**

**Co-operative membership of fishermen:**

Table 4.2 indicated the various types of cooperatives to which fish farmers belong to. The results showed that the greater proportion of the fishers (66.7%) belong to fish farmer's cooperative, while (23.0%) belong to fish marketer's cooperative. This implies that membership of the respondents of cooperative association could enhance social capital formation, increase access to

fishing equipment's, access to credit and capacity building.

**Extension teaching methods:** Result in Table 4.2 also showed that several methods were employed by extension workers to reach the fish farmers and disseminate information on new practices to them. It indicated that majority of the fish farmers (56.4%) received extension message through individual methods, closely followed by group methods 41.0%. This implies that fisher men obtained enough information and knowledge on improved technology such as use of special improved gears, modern fishing equipment's and use of adaptive strategies to mitigate

the perceived effect of climate change in the study area.

**Number of extension contact:** The result indicated that (64.6%) of the fish farmers had less than 4 extension contact with extension agents per month. Similarly, 31.3% of the fish farmers had between 4 – 6 extension contacts with extension agents.

**Types of labour used by the fish farmers:** Table 4.2 further revealed that a greater proportion (61.0%) of the fish farmers used family labour in catching fish while (39.0%) depended on hired labour. This may be because respondents do not pay for family labour. This agrees with finding of Adewale et al., (2003) who find that family labour is cheap and enables farmers to minimize cost and maximize profit.

**Table 4.2: Distribution of respondents according to their cooperative membership, extension methods/visit, labour, access to credit, input and output obtained from fishing activities.**

Co - operative's types	frequency	percentage (%)
Consumer cooperative	10	5.1
Fish farmer's cooperative	130	66.7
Fish marketers	45	23.0
<b>Extension Methods</b>		
Individual Methods	110	56.4
Group Methods	80	41.0
<b>Cooperative membership, extension methods continue</b>		
Mass Media Methods	5	2.6
<b>Extension Visit</b>		
< 4 times	126	64.6
4– 6 times	61	31.3
>6 times	8	4.1
<b>labour</b>		
Family labour	119	61
Both family and hired labour	76	39
<b>Accesses to credit</b>		
No	184	94.4
Yes	11	5.6
<b>Total</b>	<b>195</b>	<b>100.</b>
<b>Income</b>		
≤ N 100,000	52	26.7
N 101,000 - 200,000	72	36.9
N 201,000 – 300,000	71	36.4
<b>Total</b>	<b>195</b>	<b>100</b>

Source: Field Survey, 2015

**Perception of the fish farmers on the causes of climate change**

The result in table 4.3 indicated that among human factor that causes climate change (87.2%) of the fishermen perceived deforestation as the leading

**Access to credit:** The result showed the distribution of fish farmers according to access to credit, the result revealed that majority (94.4%) do not have access to credit and only 5.6% had access to credit. The implication is that inadequate credit would reduce the use of adaptive strategies to mitigate the perceived effect of climate change in the study area.

**Income generated from fishing activities:** The result indicated that 36.9% of the fish farmers generated income of between N101, 000 – N200, 000, while 36.4% of the fishermen generated income between N201, 000 - 300, 000. This implies that majority (73.3%) of the fishermen generate moderate income of between N100,000 – 300,000.

causes of climate change and ranked 1<sup>st</sup>. similarly, 84.6% of the fishermen perceived bush burning as another causes of climate change and ranked 2<sup>nd</sup>, while increase in carbon dioxide level 84.1% ranked 3<sup>rd</sup> and over grazing ranked 4<sup>th</sup>. The implication of deforestation, bush burning as the causes of climate



change, these exposed the land surface to extreme heat which latter lead to wind and water erosion, the

erosion will wash poisonous substance to or chemical into inland water and reduce the water quality.

**Table 4.3: Perception of respondents on the causes of climate change**

Human factor *	Frequency	Percentage (%)	Rank
i. Deforestation	170	87.2	1 <sup>st</sup>
ii Bush burning	165	84.6	2 <sup>nd</sup>
v Over grazing	150	76.9	4 <sup>th</sup>
vii Increase in carbon dioxide level.	164	84.1	3 <sup>rd</sup>

Source: Field Survey, 2015

Note: \* multiple responses

**Awareness on the effect of climate change on inland fisheries.**

The result showed the level of awareness of the effect of climate change on inland fisheries. The result in Table 4.4 indicated that the fish farmers were aware of droughts, desiccation and dryness (95.9%), rise in

temperature (94.9%), reduce water quality (90.3%), some species of fish move to different area (87.2%) as sign of climate change.

**Table 4.4: Awareness on the perceived effect of climate change on inland fisheries.**

Effects *	Frequency	Percentage (%)
Droughts, desiccation and dryness	187	95.9
Rise in temperature	185	94.9
Reduce water quality	176	90.3
Some fish will move to different areas	170	87.2
Some species of fish will go extinction	150	76.9
Fluctuation in precipitation	148	75.9

Source: Field Survey, 2015

\* Multiple responses

**Constraints to adaptation strategies to mitigate the effects of climate change on inland fisheries.**

Table 4.5 showed majority (87.2%) of the respondents had problems of inadequate information. The result also revealed that lack of fund (91.3%) was another problem in adopting strategies to mitigate the perceived effect of climate change on fishing activities

in the study area. The result revealed that lack of fund (91.3%) prevents fisher folks from buying modern fishing equipment that will reduce fish catch and income as well as sources of livelihood. High cost of fishing equipment (94.9%) was another problem. The result revealed that lack of modern fishing equipment was a problem to fisher folks (94.9%),

Similarly, inadequate credit facilities (95.4%) of the fish farmers were problem too.

**Table 4.5: Constraints of adaptation strategies to mitigate the effects of climate change on inland fisheries.**

Problems in adaptation strategies *	Frequency	Percentage (%)
Inadequate information on effect of climate change	170	87.2

Inadequate Fund	178	91.3
High cost of fishing equipment	185	94.9
Lack of modern fishing equipment	185	94.9
Poor credit facilities	186	95.4

Source: Field Survey, 2015

\* Multiple responses

**Regression analysis of factors affecting perception of fisher folks on climate change effect on inland fisheries**

Table 4.6 revealed that the coefficient of determination  $R^2$  of the model is given as 0.3360 implying that the variables in the model accounted for 33.6% of

variation in the perceived effect of climate by the fish farmers. It can be seen that education, income, mitigation strategies, cooperative membership were all significant at 1% level of probability (ie  $p \leq 0.001$ ).

**Table 4.6: Regression analysis of factors affecting perception of fisher folks on climate change effect on inland fisheries**

Variables	Coefficients	Standard Error	Z – value
Constant	15.407	0.296	52.042***
Age	0.002	0.005	0.364 NS
Educational level	0.052	0.011	4.838***
Income	- 7.988E-7	0.000	- 4.262***
Mitigation strategies	0.057	0.012	4.899***
Cooperative	0.662	0.131	5.041***

Source: Field Survey, 2015

$R^2 = 0.3360$

Adjusted  $R^2 = 0.3110$

\*\*\* = 0.001

NS = Not significant

**Test of hypothesis1**

Chi - square result were used to determine the relationship between mitigation measures adopted by the fisher folks and perceived effect of climate change. The result in Table 4.12 revealed that there is significant relationship at 1% level of probability between mitigation measures adopted by the fisher folks and perceived effect of climate change. Both

effect of climate (88.277) and mitigation strategies (124.205) were significant at 1% probability level. This implies that since relationship exist, we there by reject null hypothesis and accept the alternative hypothesis that relationship do exist between the mitigation measures adopted by the fisher folks and perceive effect of climate change in the study area.

**Table 4.7: Test of Hypothesis 1**

Hypothesis	Chi – square	Df
Perceived effect of climate change	88.277***	2
Mitigation measures	124.205***	4

Source: Field survey, 2015

Df = Degree of freedom

**Conclusion**

The finding of this research concluded that the NGO government and extension agents are aware and knowledgeable about climate change (causes, effects, mitigation and adaptive measures to climate change. Many are yet to include it in their programme and yet to reach their beneficiary

### Recommendations

i Fish farmer should be taught by extension agents the mitigation measures against flooding, intense wind,

storms, and hurricane such as planting of trees, cover crops and construction of dams and canals.

ii Fish farmers should be thought by extension agents on how to practice aquaculture so as to complement fishing in the wild rivers.

iii Adequate and timely information on climate change should be provided by extension agents and NGO to enable fishermen take adequate adaptation and mitigation measures against effect of climate change in the study area.

### REFERENCES

- Adewale, J.G., Oladejo, J.A., & Ogunniyi, L.T. (2003). "Economic Contribution of Farm Children to Agricultural Production in Nigeria." *Journal of Social Science*, 10(2), 149 – 152.
- Eboh, E.C. (2009). *Social and Economic Research: Principles and Methods*. Enugu, Nigeria. Africa Institute for Applied Economics. 2<sup>nd</sup> Edition, 256. Ibadan Nigeria.
- Food and Agricultural Organization [FAO] (2005). *Increasing the contribution of small-scale fisheries to poverty alleviation and food security*. FAO Technical Guidelines for Responsible Fisheries. No. 10. Rome, FAO. PP79.
- Food and Agricultural Organization [FAO] (2007a). *The state of world fisheries and aquaculture – 2006*. Rome, FAO. 162 p.
- I.P.C.C, (2010). *Intergovernmental Panel on Climate Change Special Report on Managing the Risks of Extreme Events and Disasters to Advance Climate Change Adaptation* Press Release June, (2007): Report on managing the Risks of Extreme Events and Disasters to Advance Climate Change Adaptation, 305 – 325.
- NPC, (2006). National Population Commission, *Census Head Count, 2006*.
- Rahaman, S.A., & Umar, H.S. (2009). Measurement of Technical Efficiency and its Determinants in fishing activities in Niger State, Nigeria. *Journal of Tropical Agriculture, Food, Fish Environment and Extension*, 8(2), 90 – 96.
- World Development Report (2010) *Development an Climate Change*, Chapter 3, 10