

**ELECTRONIC  
BRAKING SYSTEMS  
Troubleshooting and Maintenance  
Manual**

**Arah, A. S.,  
Audu, R.,  
Abdulkadir, M. &  
Umar, I. Y.**

Copyright ©

Arah, A. S., Audu, R., Abdulkadir, M. &  
Umar, I. Y., 2021

ISBN: 978-978-993-194-1

**First Print 2021**

All rights reserved. No part of this publication may be reproduced or transmitted in any form by any means, electronic, mechanical, photocopying, recording or otherwise without the prior written permission of the author.

Printed by



**UNIVERSITY PRESS LTD**  
Usmanu Danfodiyo University,  
Sokoto, Nigeria

## **FOREWORD**

The Manual discussed the operation, troubleshooting and maintenance of three types of electronic braking systems that include Anti-lock Braking System (ABS), Automatic Traction Control (ATC) and Electronic Stability Control (ESC) with simplified approach to assist automobile craftsmen. The manual consists of three chapters.

Chapter one contains background information on the operation of ABS, ATC and ESC and their components that include wheel speed sensor, Electronic Control Unit (ECU), modulator valve, brake pressure sensor, active brake valve, Electronic Stability Module (ECM) and steering angle, yaw rate and lateral sensors.

Chapter two contains information on facilities and contents for troubleshooting the components of ABS, ATC and ESC that include wheel speed sensor, Electronic Control Unit (ECU), modulator valve, brake pressure sensor, active brake valve, Electronic Stability Module (ECM) and steering angle, yaw rate and lateral sensors.

Chapter three contains information on facilities and contents for the maintenance of ABS, ATC and ESC components that include wheel speed sensor, Electronic Control Unit (ECU), modulator valve, brake pressure sensor, active brake valve, Electronic Stability Module (ESM) and steering angle, yaw rate and lateral sensors.

The manual is recommended for both automobile craftsmen and master craftsmen as it will serve as a solid basis for

understanding the operation and practical techniques in troubleshooting and maintenance of electronic braking systems.

**Dr. A. M. Idris**

Associate Professor,

Department of Industrial and Technology Education,

Federal University of Technology, Minna, Nigeria.

## PREFACE

Manuals generally presents useful sources of information on competencies for automobile craftsmen. The scarcity of manual on troubleshooting and maintenance of electronic systems to satisfy the industrial needs of automobile craftsmen in Nigerian posed a serious threat to the automobile maintenance industry.

Lack of technical skills among automobile craftsmen that is partly attributed to the shortage of useful resources such as manual and shortage of Nigerian authors to address the challenge spurred the development of: **Electronic Braking Systems Troubleshooting and Maintenance Manual.**

This manual contains three chapters that covers Introduction to Electronic Braking Systems, Troubleshooting Electronic Braking Systems and Electronic Braking Systems Maintenance. Each chapter is accompanied by a series of figures and plates to aid automobile craftsmen and master craftsmen to acquire the needed skills in troubleshooting and maintenance of electronic braking systems.

It is believed that, the contents of this manual will be of significant assistance to both automobile craftsmen and master craftsmen in troubleshooting and maintenance of electronic braking systems.

## ACKNOWLEDGEMENTS

The authors wish to express their appreciation to the following individuals who tremendously contributed to the success of this manual. The authors wish to express their profound gratitude to the Deputy Dean, School of Science and Technology Education, Federal University of Technology, Minna, Nigeria, Associate Professor Abubakar Mohammed Idris for proof reading the manuscript and providing professional suggestions on the manual.

The authors are also grateful to the Postgraduate Coordinator, Department of Industrial and Technology Education, Federal University of Technology, Minna, Nigeria, Associate Professor Raymond Emmanuel for his support towards developing the manual. Special thanks to Dr. Saba Moses Tswana of the Department of Industrial and Technology Education, Federal University of Technology, Minna, Nigeria for his professional guidance towards the success of this manual. The authors also appreciate Mr. Justice Lakat Vongjen, Head of Vocational Enterprises Institute, Karshi, Abuja for his moral support.

The authors acknowledge the technical expertise of Major Agene Boniface Ibrahim, Head of AFEME Mechatronic School, Mogadishu Cantonment, Abuja; Engr. Kolapo Odetoro and Engr. Francis Udeh of National Automotive Design and Development Council, Abuja; Engr. Zubair Abdullah and Mr. Aliyu Zakari (Hamza) of Industrial Training Fund, Nigeria; Mr. Olaitan Moses Oluwafemi of Business Apprenticeship Training Centre, Zaria; Engr. Tech Joyce Daser Adams, CEO Autolady Engineering Technology Nigeria Limited, Abuja; and Sandra Aguebor, CEO Lady Mechanic Initiative, Lagos in ensuring the manual is valid and reliable.

The authors also appreciate the staff of Industrial and Technology Education Department, Federal University of Technology, Minna, Nigeria, for their support.

# TABLE OF CONTENTS

	<b>Page</b>
Title Page	i
Foreword	iii
Preface	v
Acknowledgements	vi
Table of Contents	ix
List of Tables	xiii
List of Figures	xiv
List of Plates	xv

## **CHAPTER ONE: INTRODUCTION TO ELECTRONIC BRAKING SYSTEMS**

1.0	Objectives	1
1.1	Electronic Braking Systems	1
1.2	Anti-lock Braking System	2
1.2.1	Wheel Speed Sensing Unit	3
1.2.2	Electronic Control Unit (ECU)	4
1.2.3	Pressure Modulator Valves	5
1.2.4	Brake Pressure Sensor	6
1.3	Automatic Traction Control System	7
1.3.1	Active Braking Valve	9
1.4	Electronic Stability Control	10
1.4.1	Electronic Stability Control Module	12
1.4.2	Steering Angle Sensor	13
1.4.3	Yaw Rate Sensor	14
1.4.4	Lateral Acceleration Sensor	15



## **CHAPTER TWO: TROUBLESHOOTING ELECTRONIC BRAKING SYSTEMS**

2.0	Objectives	16
2.1	Concept of Troubleshooting	16
2.2	Diagnosis	17
2.2.1	Facilities for Diagnosis	17
2.2.2	Contents for Diagnosis	17
2.3	Troubleshooting Electronic Braking Systems	19
2.3.1	Facilities for Troubleshooting	19
2.4	Troubleshooting Wheel Speed Sensor	20
2.4.1	Contents for Troubleshooting Wheel Speed Sensor	21
2.5	Troubleshooting Electronic Control Unit	22
2.5.1	Contents for Troubleshooting Electronic Control Unit	23
2.6	Troubleshooting Pressure Modulator Valve	24
2.6.1	Contents for Troubleshooting Pressure Modulator Valve	25
2.7	Troubleshooting Brake Pressure Sensor	26
2.7.1	Contents for Troubleshooting Brake Pressure Sensor	27
2.8	Troubleshooting Active Braking Valves	28
2.8.1	Contents for Troubleshooting Active Brake Valve	28
2.9	Troubleshooting Electronic Stability Control Module	29
2.9.1	Contents for Troubleshooting Electronic Stability Control Module	31
2.10	Troubleshooting Steering Angle Sensor	32
2.10.1	Contents for Troubleshooting Steering Angle Sensor	34
2.11	Troubleshooting Yaw Rate Sensor	35
2.11.1	Contents for Troubleshooting Yaw Rate Sensor	36
2.12	Troubleshooting Lateral Acceleration Sensor	37
2.12.1	Contents for Troubleshooting Lateral Acceleration Sensor	38

## **CHAPTER THREE: ELECTRONIC BRAKING SYSTEMS MAINTENANCE**

3.0	Objectives	39
3.1	Concept of Maintenance	39
3.2	Wheel Speed Sensor Maintenance	42
3.2.1	Facilities for the Maintenance of Wheel Speed Sensor	44
3.2.2	Contents for the Maintenance of Wheel Speed Sensor	44
3.3	Electronic Control Unit Maintenance	46
3.3.1	Facilities for the Maintenance of Electronic Control Unit	46
3.3.2	Contents for the Maintenance of Electronic Control Unit	47
3.4	Pressure Modulator Valves Maintenance	47
3.4.1	Facilities for the Maintenance of Pressure Modulator Valves	49
3.4.2	Contents for the Maintenance of Pressure Modulator Valves	50
3.5	Brake Pressure Sensor Maintenance	51
3.5.1	Facilities for the Maintenance of Brake Pressure Sensor	52
3.5.2	Contents for the Maintenance of Brake Pressure Sensor	53
3.6	Active Braking Valves Maintenance	53
3.6.1	Facilities for the Maintenance of Active Braking Valves	55
3.6.2	Contents for the Maintenance of Active Braking Valves	56
3.7	Electronic Stability Control Module Maintenance	57
3.7.1	Facilities for the Maintenance of Electronic Stability Control Module	58
3.7.2	Contents for the Maintenance of Electronic Stability Control Module	58
3.8	Steering Angle Sensors Maintenance	59

3.8.1	Facilities for the Maintenance of Steering Angle Sensor	61
3.8.2	Contents for the Maintenance of Steering Angle Sensors	62
3.9	Lateral Acceleration and Yaw Rate Sensors Maintenance	63
3.9.1	Facilities for the Maintenance of Yaw Rate and Lateral Acceleration Sensors	65
3.9.2	Contents for the Maintenance of Lateral Acceleration and Yaw Rate Sensors	65
	REFERENCES	67

## LIST OF TABLES

<b>Table</b>		<b>Page</b>
2.1	Facilities for Troubleshooting Electronic Braking Systems and their Uses	20
2.2	Electronic Control Unit Locations and Measurements	23
2.3	Electronic Stability Control Module Circuit and Measurement	30
2.4	Steering Angle Sensor Location and Measurements	33
2.5	Yaw Rate Sensor Connector Pin, Condition and Measurements	36
3.1	Facilities for the Maintenance of Electronic Braking Systems and their Uses	40

## LIST OF FIGURES

<b>Figure</b>		<b>Page</b>
1.1	Operation of Anti-lock Braking System	3
1.2	Wheels Sensing Unit	4
1.3	Electronic Control Unit	5
1.4	Pressure Modulator Valve	6
1.5	Brake Pressure Sensor	7
1.6	Operation of Automatic Traction Control	9
1.7	Active Braking Valves	10
1.8	Operation of Electronic Stability Control System	12
1.9	Steering Angle Sensor	14
2.1	Plugging standard OBD-II connector into the vehicle's data link connector	18
2.2	Pressure Modulator Valve Connector	25
2.3	Brake Pressure Sensor Connector	27
2.4	Electronic Stability Control Module Connector	31
2.5	Steering Angle Sensor Connector	34
2.6	Yaw Rate Sensor Connector	36
2.7	Lateral Acceleration Sensor 6 Way Connector	38
3.1	Location of Wheel Speed Sensor	42
3.2	Wheel Speed Sensor, Holder and Spring Clip	43
3.3	Pressure Modulator Valve Ports to be Disconnected	48
3.4	Active Braking Valves Ports to be Disconnected	54
3.5	Removing the Yaw Rate & Lateral Acceleration Sensor	64

## LIST OF PLATES

<b>Plate</b>		<b>Page</b>
I	Unplugging The Electrical Connector of Brake Pressure Sensor	52
II	Location of the Steering Angle Sensor on Steering Column Shaft	60

# **CHAPTER ONE**

## **INTRODUCTION TO ELECTRONIC BRAKING SYSTEMS**

### **1.0 Objectives**

By the end of studying this chapter, automobile craftsmen should be equipped with the operational knowledge of the three types of electronic braking systems that include:

1. Anti-lock Braking System (ABS),
2. Automatic Traction Control (ATC) and
3. Electronic Stability Control (ESC).

### **1.1 Electronic Braking Systems**

Electronic braking systems are additional safety systems incorporated into the primary braking system that usually come into play during emergency situations. These systems reduce braking distance by several meters, which can be decisive in some situations. The systems increases braking comfort and improved vehicle safety. Man (2019) disclosed that, the outstanding features of electronic braking systems are: electronic activation of all braking system components, retarder and engine brake integration into the service brake application, brake force distribution adapts to load distribution, brake compatibility between tractor and trailer, comfortable deceleration control and continuous self-testing via integrated diagnostic and monitoring functions. Wabco (2019) confirmed that, Anti-lock Braking System (ABS), Automatic Traction Control (ATC) and Electronic Stability Control (ESC) to be the common types of electronic braking systems.

## **1.2 Anti-lock Braking System**

Anti-lock Braking System (ABS) is an automobile safety system designed to prevent vehicle wheels from locking and avoiding uncontrolled skidding as a result of the service brake being applied with too much force, especially on slippery road surfaces. According to Hiroshi and Shingo (2015), ABS maintain cornering forces on braked wheels to ensure that the vehicle or vehicle combination retains its driving stability and maneuverability as far as physically possible. The ABS do not necessarily reduce the stopping distance, and in fact may actually increase stopping slightly on dry pavement. On wet or slick pavement, ABS may reduce the stopping distance up to 25% or more, which could be the difference between a safe stop and an accident (Carley, 2019). The ABS generally offers improved vehicle control and decreases stopping distances on dry and slippery surfaces; however, on loose gravel or snow-covered surfaces, ABS can significantly increase braking distance, although still improving vehicle control. Divyata and Anjali (2016) noted that, ABS have several advantages which include the following:

1. Guarantees stable braking characteristics on all road surfaces, hence avoids overturning of the vehicle.
2. Reduces friction on wheels and road, thus increases efficiency of tires (up to 30%).
3. Vehicle with ABS can be stopped at a lesser distance than a non-ABS vehicle.
4. Steering control is effective which entails that, vehicle can be steered smoothly while braking. Thus, accidents are minimized.



5. A driver without experience can drive ABS vehicle effectively compared to an experienced driver on the non-ABS vehicle.

Typically, ABS consists of wheel speed sensing unit, ABS module, modulator valves and brake pressure sensor as shown in Figure 1.1.

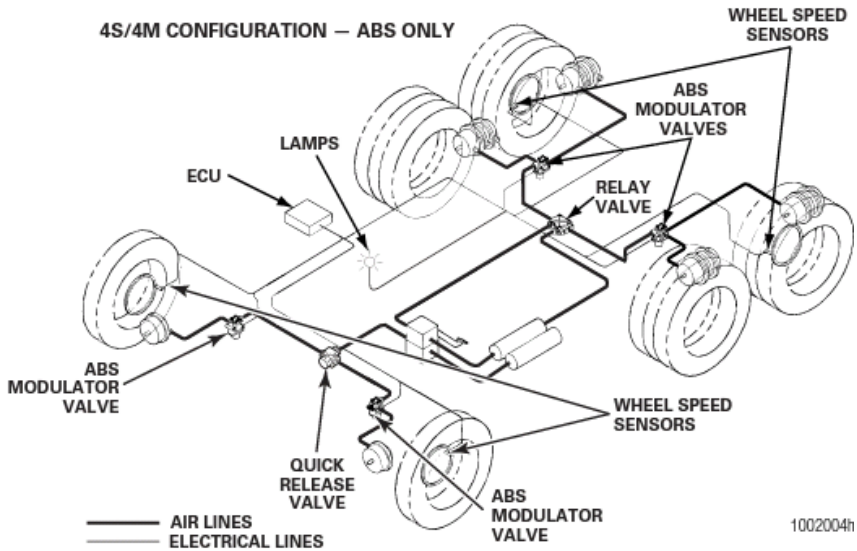

**Figure 1.1: Operation of Anti-lock Braking System**

**Source:** Wabco (2019)

### 1.2.1 Wheel Speed Sensing Unit

Wheel speed sensing unit consist of a tooth wheel mounted on the hub or rotor of each monitored wheel and a wheel speed sensor installed with its end against the tooth wheel. The unit also consist of a sensor clip that holds the sensor in place and against the tooth wheel as shown in Figure 1.2. The sensor continuously sends wheel speed information to the ECU. Each of

the ABS wheel speed sensors detects the speed of the corresponding wheel. The sensor consists of a permanent magnet, coil and tone wheel. Chankit *et al.* (2014) stated that, the magnetic flux produced by the permanent magnet changes as each tooth of the tone wheel (which rotates together with the wheel) passes in front of the magnet's pole piece. The changing magnetic flux induces voltages at a frequency corresponding to the wheel speed.

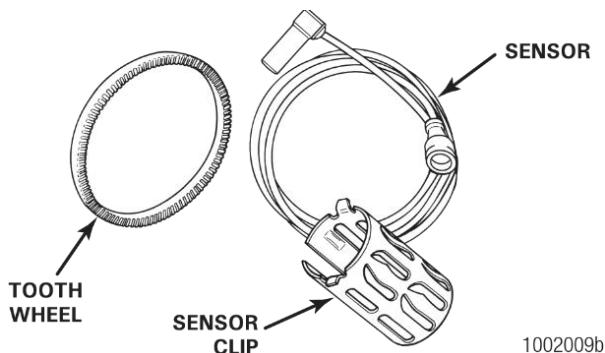

**Figure 1.2: Wheels Sensing Unit**

**Source:** Wabco (2019)

### **1.2.2 Electronic Control Unit (ECU)**

The ECU is the control center or brain of the ABS, ATC and ESC systems. ABS receives information from the sensors, processes data and sends signals to modulators and active braking valves to achieve different tasks. The work of ECU is to receive, amplifies and filter the sensor signals for calculating the speed rotation and acceleration of the vehicle (Ayman *et al.*, 2011). The ECU also uses the speeds of road wheels to calculate an estimate for the speed of the vehicle. Jitesh (2014) noted that, the slip of each wheel is obtained by comparing the reference

speed with the individual wheel. During wheel slip or wheel acceleration condition signal server to alert the ECU. The microcomputer alert by sending the trigger the pressure control valve of the solenoids of the pressure modulator to modulate the brake pressure in the individual wheel brake cylinders. According to Seibum (2018), the ECU reacts to a recognized defect or error by switching off the malfunctioning part of the system or shutting down the entire system. The diagram of ECU is shown in Figure 1.3.

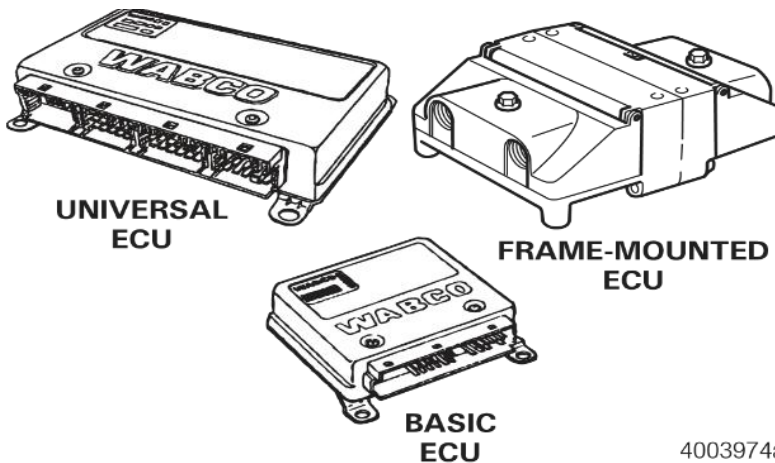

**Figure 1.3: Electronic Control Unit**

**Source:** Wabco (2019)

### **1.2.3 Pressure Modulator Valves**

A pressure modulator valve controls air pressure to an affected wheel-end brake during an ABS, ATC or ESC event to reduce speed and prevent wheel lock up. Pressure modulator valves are also used during ATC events to properly gain traction on the affected wheel end. A pressure modulator valve is usually located

on a frame rail or cross member near the brake chamber or as part of a valve package. Pressure modulator valves consists of inlet and outlet ports as well as connector unit as shown in Figure 1.4.

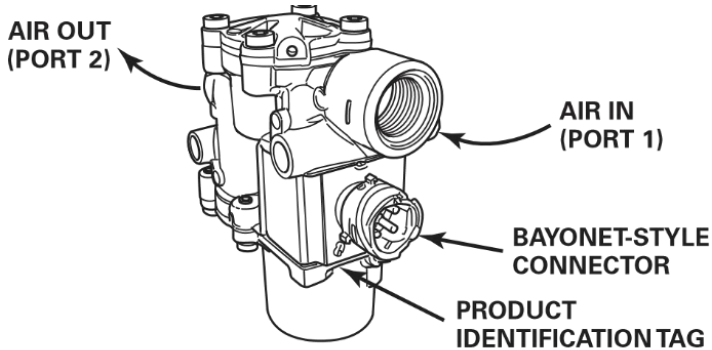
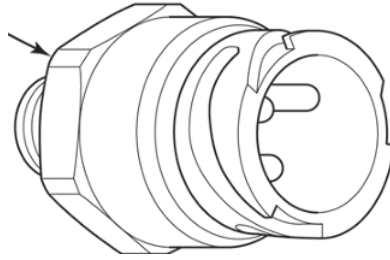

**Figure 1.4: Pressure Modulator Valve**

**Source:** Wabco (2019).

#### **1.2.4 Brake Pressure Sensor**

Brake pressure sensor is part of the ABS, ATC and ESC that senses the brake fluid pressure in a hydraulic unit of the systems. The sensor is a type of pressure switch that shows and alerts a fault in the braking system. The sensor is used to detect pressure differentials in the hydraulic system. Dang (2017) stated that, if the car alerts a fault in the hydraulic system and the system checks out, the sensor itself may have failed. The sensor can be located in the primary or secondary delivery circuit depending on the application. A brake pressure sensor is shown in Figure 1.5.



**Figure 1.5: Brake Pressure Sensor**

**Source:** Wabco (2019)

### **1.3 Automatic Traction Control System**

Automatic Traction Control (ATC) system is an option that is often found on vehicles equipped with ABS. The ATC is essentially an additional feature to ABS that improves traction when the vehicle is accelerating on a wet or slick surface, or is accelerating too quickly for the tires to maintain their grip. Ran *et al.* (2016) disclosed that, ATC prevents wheel spin by applying the brakes on the drive wheel that is losing traction, and/or momentarily reducing engine torque by various methods. The ATC helps improve traction in low traction road conditions. According to Jin *et al.* (2017), ATC reduces the potential of jackknifing caused by excessive wheel spin during acceleration or in curves. The ATC works automatically in two different ways that include the following:

- i. When one drive wheel is spinning at a different speed than the other, ATC momentarily applies the brake until traction is regained.
- ii. When both drive wheels are spinning on a poor-traction surface, ATC automatically reduces engine power to attain optimum tire-to-road traction.

The ATC will automatically turn on and off as driver's input is not required to turn this feature on. If the vehicle experiences a traction control event, the ATC indicator lamp will come on, indicating ATC is active. The light turns off when the event has ended. The main difference between ABS and ATC, therefore, is that ABS only comes into play when braking while ATC only comes into play while accelerating. According to Yang *et al.* (2015), ATC shares many of the same components and sensor inputs with the ABS system as shown in Figure 1.6. These similarities include the following:

- i. A common control module is often used with additional software and control circuits for ATC. In some vehicles, a separate ATC control module may be used.
- ii. The same wheel speed sensors are used to monitor wheel speeds.
- iii. The same pump and high pressure accumulator are used to generate and store hydraulic pressure for ATC braking.
- iv. The same modulator (with a couple of extra solenoid valves) is used to control braking.

Typically, ATC adds an extra solenoid valve sometimes called Active Braking Valves.

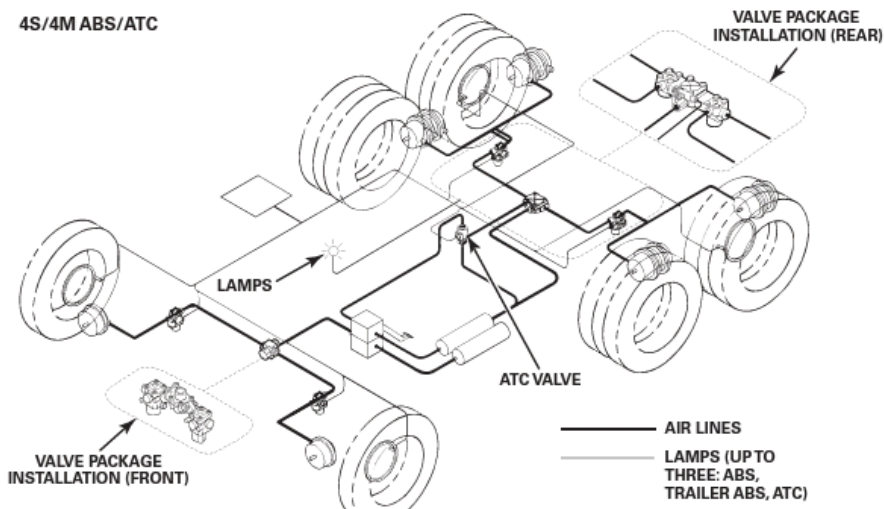

**Figure 1.6: Operation of Automatic Traction Control**

**Source:** Wabco (2019)

### 1.3.1 Active Braking Valve

The Active Braking Valve (ABV) is sometimes referred to as 3/2 valve, are solenoid valves used for active braking during ATC or ESC events. The ABV is shown in Figure 1.7. Depending on system configurations, ABVs can be located in the front axle braking system or rear axle braking system in the ABS modulator for each drive wheel's brake circuit. This allows the system to apply pressure to slow the drive wheel if the wheel starts to spin. The ABS solenoids for the same brake circuit may also be called into play to hold, release and reapply pressure as needed until traction is regained. Most ATC systems will discontinue braking after a certain length of time or after so many repeated braking applications to prevent the brakes from overheating (as when driving in mud or snow). If both wheels are losing traction, traction control may brake both wheels equally to slow them

down enough so that they can regain traction, and/or it may also send a request to the Electronic Control Unit (ECU) to reduce engine torque until traction is regained.

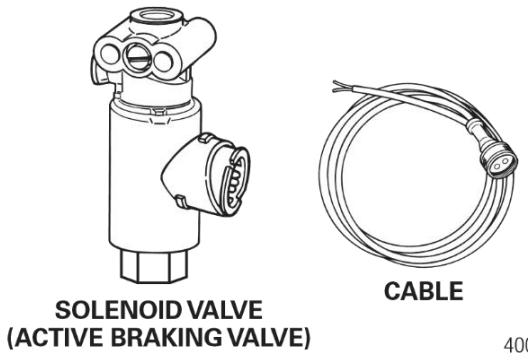

**Figure 1.7: Active Braking Valves**

**Source:** Wabco (2019)

## 1.4 Electronic Stability Control

The Electronic Stability Control (ESC) is a safety system that supports the driver in nearly all critical driving situations. The ESC helps drivers to avoid crashes by reducing the danger of skidding, or losing control as a result of over-steering. The ESC becomes active when a driver loses control of the car. According to Pawan (2016), ESC is the most important safety feature since seat belts as it has proven itself as an important technology from time to time by avoiding the vehicle from under steering and over steering preventing roll over and giving better control. The system doesn't work all alone as it uses the automobile other safety and regulatory devices, such as the Anti-lock Braking System (ABS) and Automatic Traction Control (ATC) to correct problems before they become accidents. Kristen (2019) stated that, ESC comprises the functions of the ABS and that of ATC as



well as do considerably more in providing lateral safety. The ESC system offers value-added functions that assist the driver when starting off on inclines by independently applying the brakes for around two seconds after the driver has released the brake pedal. The system can also protect vehicles with a high center of gravity from the risk of rolling over (Bosch, 2019). If the vehicle is not going in the direction the driver is steering, the ESC system uses individual wheel brakes to maintain control.

The incorporation of ESC has become a standard in many vehicles produced since 2012. According to Olathe (2016), the ESC systems must meet certain minimum requirements.

- i. It must be able to apply all four brakes individually. It must also have a control of the algorithm that utilizes this capability.
- ii. It must be capable and operational during all phases of driving (acceleration, coasting, and deceleration).
- iii. It must stay operational while the antilock braking system or the traction control system is active.

The ESC system utilizes onboard computers known as electronic stability control module to monitor vehicle direction and stability by receiving data from several sensors as shown in Figure 1.8.

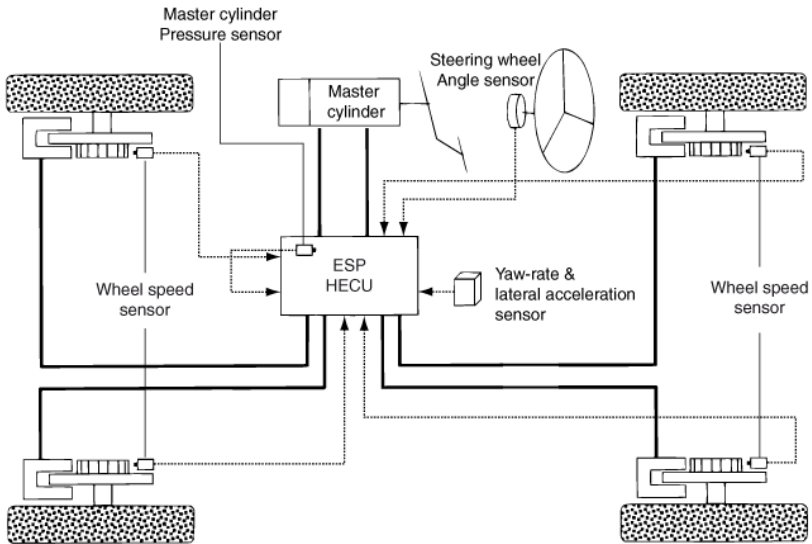

**Figure 1.8: Operation of Electronic Stability Control System**

Source: Kia (2017)

### 1.4.1 Electronic Stability Control Module

The electronic stability control module is a control unit that is considered as the processor and the brain of the entire ESC. It receives voltage, earth and Control Area Network (CAN) communication from the ECU. From this data, the ECU calculates the actual movement of the vehicle, comparing it 25 times per second with the desired direction of travel (Automotive System Engineering Study Guides, 2019). If the values do not correspond, the system reacts in an instant, without any action on the part of the driver. It reduces engine power in order to restore vehicle stability. If that is not sufficient, then it additionally brakes individual wheels. The information generated by the installed sensors of the ESC system, such as the wheel speed,

lateral acceleration, yaw and steering angle sensors, is received by the ESC module. Jung *et al.* (2010) noted that, the ESC module then utilizes this data, processes it and generates the electronic signals to ensure that the vehicle's ESC system effectively prevent the vehicle from losing the traction and remain stable on the roads. The ECU continuously monitors vehicle steering and direction using input data from sensor. These sensors include the wheel speed sensors, steering angle sensors, yaw rate sensors and lateral acceleration sensors.

### **1.4.2 Steering Angle Sensor**

The steering angle sensor is used to inform the ESC module of the driver's intended direction using a dedicated ESC system internal data link. The ESC module supplies the sensor with voltage and earth. It takes this information and compares it to the vehicle's actual direction in order to make an informed braking decision. According to Kalwinder (2013), these decisions are based on factory set parameters. The sensor is located on the steering shaft and looks like a small clock spring. The steering angle sensor must be calibrated using diagnostic tools whenever it is replaced, or when any vehicle steering components are replaced or adjusted. A typical Steering Angle Sensor is shown in Figure 1.9.

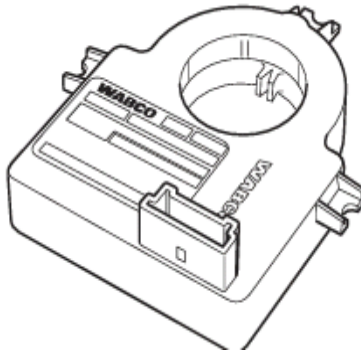

**Figure 1.9: Steering Angle Sensor**

**Source:** Wabco (2019)

### **1.4.3 Yaw Rate Sensor**

The yaw rate sensor determines whether the car is developing a tendency to spin around the vertical axis. The yaw rate sensor is a key component in a ESC designed to provide motorists with increased safety, security, and control even in the most difficult driving conditions. It helps the ESC module to determine the current driving-dynamic state of the car. For this purpose, it must be placed close to the vehicle's centre of gravity. According to Kawaguchi *et al.* (2013), yaw rate sensor measures a vehicle's angular velocity about its vertical axis in degrees or radians per second in order to determine the orientation of the vehicle as it hard-corners or threatens to roll-over. By comparing the vehicle's actual yaw rate to the target yaw rate, the on-board computer can identify to what degree the vehicle may be under- or over-steer, and what corrective action, if any is required. Standard Motor (2019) noted that, the corrective action may include reducing engine power as well as applying the brake on one or more wheels to realign the vehicle.

#### **1.4.4 Lateral Acceleration Sensor**

The lateral acceleration sensor measures the lateral acceleration of the vehicle in order to determine the actual position of the vehicle. It can be located on the same housing as that of the yaw sensor. According to Koenning and Heger (2019), a typical passive safety sensor like lateral acceleration sensor determines the extent of vehicle crash based on impact velocity, type of crash such as offset crash, full frontal crash, and mass of the crash participant. The key role of the acceleration sensor as discussed by Pack (2015) includes the following:

**Pedestrian protection:** When lateral acceleration sensor is used in the bumper, it detects the collision with a pedestrian and activates the 'pop up' hood by a pyrotechnical activation thereby reducing the degree of freedom of acceleration of the vehicle, and protecting the pedestrian in case of an unavoidable accident.

**Occupant safety:** Lateral acceleration sensor generates an optimized firing choreography and activates the available restraint systems to reduce the injury risk of the occupant. Lateral acceleration and yaw rate sensors are located in the middle of the vehicle beneath the driver's seat.

# **CHAPTER TWO**

## **TROUBLESHOOTING ELECTRONIC BRAKING SYSTEMS**

### **2.0 Objectives**

By the end of studying this chapter, automobile craftsmen should be able to effectively carry out troubleshooting of electronic braking systems components that include: wheel speed sensor, Electronic Control Unit (ECU), modulator valve, brake pressure sensor, active brake valve, Electronic Stability Module (ECM) and steering angle, yaw rate and lateral sensors.

### **2.1 Concept of Troubleshooting**

Troubleshooting is a form of problem solving often applied to the maintenance of failed products or processes on a system. Troubleshooting could be seen as a logical and systematic search for the source of a problem in order to solve it and make the product or process operational again. According to Michael (2018), troubleshooting is a systematic approach to problem solving which is lacked by technicians in order to effectively carry out maintenance on modern automobiles. Effective troubleshooting of electronic braking systems entails identifying the symptoms of malfunction, determining the most likely cause and eliminating the potential causes. Matthew and Rouse (2018) noted that, vast majority of automobile equipped with electronic braking systems suffer disrepair due to lack of troubleshooting skills on the part of automobile craftsmen. The first step in troubleshooting electronic braking systems is to carryout On-Board Diagnosis

## **2.2. Diagnosis**

The Electronic Control Unit (ECU) monitors and manages the system the operating parameters of every component connected to the electronic systems. When the ECU sees a signal that is outside normal limits, or fails to see an expected change in a signal, it stores a Diagnostic Trouble Codes (DTCs). To access DTCs, a scan tool is connected to a Diagnostic Link Connector that is commonly located under the driver's side of the dashboard. According to Leonardo (2019), the scan tool displays any stored DTCs, but that is only the beginning of a full diagnostics troubleshooting. Baek and Jang (2015) confirmed that, diagnosing automobile systems include the following facilities and contents:

### **2.2.1 Facilities for Diagnosis**

- i. OBD II scan tool (code reader, computer and smartphone)
- ii. Adopter
- iii. Data cable
- iv. Data Trouble Codes interpretation

### **2.2.2 Contents for Diagnosis**

- i. Select the right diagnostic tool
- ii. Ensure the diagnostic tool is functional
- iii. Check the dashboard light
- iv. Access the steering hood
- v. Locate the OBD-II data link connector (under the driver's side of the dashboard)
- vi. Plug the standard OBD-II connector into the vehicle's

data link connector as shown in figure 2.1.

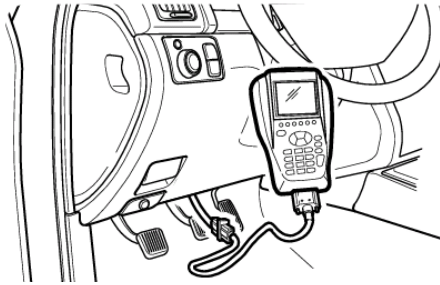

**Figure 2.1: Plugging standard OBD-II connector into the vehicle's data link connector**

**Source:** Baek and Jang (2015)

- vii. Turn the car's key to provide power to the scan tool or code reader
- viii. Enter the vehicle-specific information requested
- ix. To check for engine codes, press the scan button on the code reader
- x. Follow the directions on the screen
- xi. Record the Diagnostic Trouble Codes
- xii. Translate the Diagnostic Trouble Codes
- xiii. Clear the reported Diagnostic Trouble Codes

Nevertheless, the DTCs don't tell if a particular component or system is bad, they only indicate that the ECU has seen something it didn't expect in a certain circuit. Draganov *et al.* (2007) stated that, to troubleshoot a problem, the technician starts with the retrieving DTC, then performs troubleshooting procedures. These can range from visual inspection and



individual component testing.

## **2.3 Troubleshooting Electronic Braking Systems**

Troubleshooting contents for the electronic braking systems manual refers to the safety and troubleshooting competencies in diagnosing, checking and measuring the components of electronic braking systems that include ABS, ATC and ESC. These competencies include the use of On-Board Diagnostics, electronic measuring instruments and visual inspection in finding faults and causes of the faults. The functions of the facilities required for diagnosing and troubleshooting are shown in Table 2.1.

### **2.3.1 Facilities for Troubleshooting:**

- i. Wiring diagrams
- ii. Stethoscope
- iii. 12 volt test lamp
- iv. Voltmeter
- v. Ohmmeter
- vi. Multi meter
- vii. 2-4 amp sealed lamp

**Table 2.1: Facilities for Troubleshooting Electronic Braking Systems and their Uses**

S/N	Facilities	Uses
1.	Mechanic's stethoscope	To listen to and track noises found within the vehicle
2.	12-volt test light	For testing the supply of voltage in ECU and its harness circuits
3.	Circuit tester	For testing a fuse or circuit. If power is present, the bulb will illuminate confirming the circuit has power and is operating properly
4.	Voltmeter	For measuring electric potential difference between two points in the ECU CAN, ground and sensors
5.	Ohmsmeter	For measuring electrical resistance of ECU harness, modulator valve connection and sensors
6.	2-4 amp sealed lamp	To illuminate the working area

**Source:** Author

#### **2.4. Troubleshooting Wheel Speed Sensor**

A wheel speed sensor is used by the anti-lock brakes to determine if a wheel is moving at a different speed than the others in order to control the ABS and ATC functions. A faulty wheel speed sensor usually illuminates dashboard lights for the ABS or ATC systems and the system will likely not function properly. According to David (2011), when troubleshooting a wheel speed sensor, all readings should be taken at the same time

and before vehicle is driven because its resistance can change with temperature. Troubleshooting a wheel speed sensor entails competencies in sensor adjustment that include pushing the sensor in until it contacts the tooth wheel and not pushing sensors with sharp objects. Chris (2016) stated that, troubleshooting a wheel speed sensor require electrical testing skills that include testing the resistance of wheel speed sensor, testing the resistance of ECU harness, verifying no change in resistance and no open circuit between sensor and ECU harness. Checking harness for any short circuit from the battery and the harness. According to Wabco (2019), measurements from testing a wheel speed sensor should read as follows: between sensor leads, 900-2000 ohms; at ECU harness pins with sensor connected, 900-2000 ohms (no more than 1-ohms difference is okay); at ECU harness for DC voltage, no continuity and sensor output voltage should read at least, 0.2 volt.

#### **2.4.1 Contents for Troubleshooting Wheel Speed Sensor**

- i. Ensure the ABS lamp is operating
- ii. All readings should be taken at the same time and before vehicle is driven
- iii. Do not pry or push sensors with sharp objects
- iv. Push the sensor in until it contacts the tooth wheel
- v. Check the resistance of wheel speed sensor
- vi. Check the resistance of ECU harness
- vii. Verify no change in resistance
- viii. Verify no open circuit between sensor and ECU harness
- ix. Check harness for any shorts to battery

- x. Check harness for any shorts to ground
- xi. Ensure measurement between sensor leads is 900-2000 ohms
- xii. Ensure measurement at ECU harness pins with sensor connected is 900-2000 ohms
- xiii. Ensure no continuity at ECU harness for DC voltage or ground
- xiv. Ensure sensor output voltage is at least, 0.2 volt

## **2.5 Troubleshooting Electronic Control Unit**

The Electronic Control Unit (ECU) is the control center or brain of the automobile electronic systems that receives, amplifies and filters various sensors signals such as the wheel speed sensors signal for calculating the speed rotation and acceleration of the vehicle. A faulty ECU render all electronic systems as well as the automobile inactive. Troubleshooting ECU entails verifying vehicle batteries, charging system and fuses are in good working condition. According to Gillespie (2013), troubleshooting ECU entails load testing battery and ignition circuits to ground at the ECU harness using a 2-4 amp sealed lamp and verify lamp does not flicker and it is on steady. Nevertheless, Shi *et al.* (2012) stated that, troubleshooting ECU also involve taking measurements at the ECU harness pins. Wabco (2019) noted that, measurements in troubleshooting ECU module should read as shown in Table 2.2.

**Table 2.2: Electronic Control Unit Locations and Measurements**

<b>Location</b>	<b>Measurements</b>
Supply Voltage, Battery to chassis Ground	9.0-16.0V for 12V system 18.0-32.0V for 24V system
Supply Voltage, Ignition to chassis Ground	9.0-16.0V for 12V system 18.0-32.0V for 24V system
ECU ground to chassis ground	Less than 1 ohms resistance
Main ground to chassis ground	Less than 1 ohms resistance

**Source:** Wabco (2019)

### **2.5.1 Contents for Troubleshooting Electronic Control Unit**

- i. The ECU connectors must be plugged in before troubleshooting
- ii. Do not load test across power and earth at the ECU when troubleshooting
- iii. Verify vehicle batteries connections for tightness
- iv. Verify charging system for good operation
- v. Verify fuses
- vi. Load testing battery and ignition circuits to ground at the ECU harness
- vii. Ensure that lamp does not flash
- viii. Take measurements at the ECU harness pins

- ix. Ensure measurement of supply voltage at battery to chassis ground reads 9.0-16.0V for 12V system
- x. Ensure measurement of supply voltage at battery to chassis ground reads 18.0-32.0V for 24V system
- xi. Ensure measurement of supply voltage at ignition to chassis ground reads 9.0-16.0V for 12V system
- xii. Ensure measurement of supply voltage at ignition to chassis ground reads 18.0-32.0V for 24V system
- xiii. Ensure measurement at ECU ground to chassis ground reads less than 1 ohms resistance
- xiv. Ensure measurement at main ground to chassis ground reads less than 1 ohms resistance

## **2.6 Troubleshooting Pressure Modulator Valve**

A pressure modulator valve controls air pressure to an affected wheel-end brake during an ABS, ATC or ESC event to reduce speed and prevent wheel lock up. A faulty pressure modulator valve usually illuminates dashboard lights for the ABS or ATC systems and the system will likely not function properly. Troubleshooting pressure modulator require skills in electrical testing that include testing the modulator valve for resistance, testing ECU harness and modulator valve together for resistance, verifying no change in resistance or open circuit between valve and harness as well as checking harness for any shorts to battery and shorts to ground. According to Poursamad (2009), if resistance exceeds 9.0 ohms for 12V system (21.0 ohms for 24V system), verify the reading was not taken between the inlet and outlet (as shown in Figure 2.2) and if the correct pins were tested, cleaning the electrical contacts at the modulator is required.

Wabco (2019) recommended that, measurements should read as follows: at inlet valve pin to Ground, 4.0-9.0 ohms for 12V system and 11.0-21.0 ohms for 24V system; at outlet valve pin to ground, 4.0-9.0 ohms for 12V system and 11.0-21.0 ohms for 24V system and at ECU harness pins with modulator valve connected, 4.0-9.0 ohms for 12V system and 11.0-21.0 ohms for 24V system (no more than 1-ohms difference is okay).

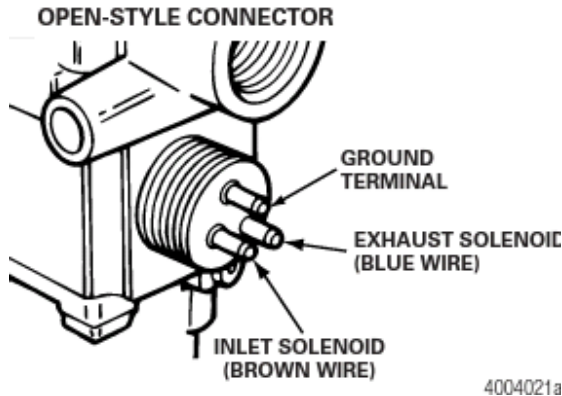

**Figure 2.2: Pressure Modulator Valve Connector**

**Source:** Wabco (2019)

### 2.6.1 Contents for Troubleshooting Pressure Modulator Valve

- i. If resistance exceeds 9.0 ohms for 12V system (21.0 ohms for 24V system), verify whether the reading was not taken between the inlet and outlet
- ii. If the correct pins were tested, clean the electrical contacts at the modulator and retest
- iii. Check pressure modulator valve for resistance
- iv. Check ECU harness and modulator valve together for resistance
- v. Verify no change in resistance or open circuit between

- valve and through harness
- vi. Check harness for any shorts to battery and shorts to ground
  - vii. Ensure measurement at inlet valve pin to ground reads 4.0-9.0 ohms for 12V system
  - viii. Ensure measurement at inlet valve pin to ground reads 11.0-21.0 ohms for 24V system
  - ix. Ensure measurement at outlet valve pin to ground reads 4.0-9.0 ohms for 12V system
  - x. Ensure measurement at outlet valve pin to ground reads 11.0-21.0 ohms for 24V system
  - xi. Ensure measurement at ECU harness pins with modulator valve connected reads 4.0-9.0 ohms for 12V system
  - xii. Ensure measurement at ECU harness pins with modulator valve connected reads 11.0-21.0 ohms for 24V system
  - xiii. Ensure no continuity at ECU harness for battery voltage or ground

## **2.7 Troubleshooting Brake Pressure Sensor**

The brake pressure sensor is used to detect pressure differentials in the hydraulic system. One of the common failures on an ABS, ATC and ESC is a failed brake pressure sensor. A light generally illuminates on dashboard and there are physical braking issues as well. You may notice wheel lock up under braking, vibration in the brake pedal, or several other issues. According to Jeff (2017), when troubleshooting brake pressure sensor, all of the ECU connectors must be plugged in as the ECU provides voltage and ground to the brake pressure sensor. Troubleshooting brake pressure sensor require skills in electrical testing that include



taking measurements at the pressure sensor harness connector, measuring voltage supply to Ground on Pin 1 of the brake pressure sensor connector (Figure 2.3) with key ON. With ECU and brake pressure sensor disconnected, verify continuity end to end on all 3 lines, no shorts to ground or battery on all 3 lines and no continuity between pins as shown in Figure 2.3. Nevertheless, according to Wabco (2019), measurements should read as, Voltage supply to Ground, 8.0-16.0V.

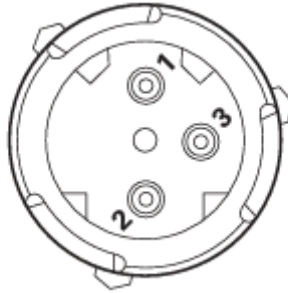

**Figure 2.3: Brake Pressure Sensor Connector**

**Source:** Wabco (2019)

### **2.7.1 Contents for Troubleshooting Brake Pressure Sensor**

- i. The ECU connectors must be plugged in when testing brake pressure sensor harness connector for voltage
- ii. The ECU connectors must be unplugged when verifying short to ground and continuity
- iii. Take measurements at the brake pressure sensor harness connector
- iv. Measure voltage supply to ground on pin 1 of the brake pressure sensor with connector key on
- v. Verify continuity end to end on all 3 lines
- vi. Ensure no shorts to ground or battery on all 3 lines
- vii. Ensure no continuity between pins

## **2.8 Troubleshooting Active Braking Valves**

The active braking valves can be located in the front axle braking system or rear axle braking system in the ABS modulator for each drive wheel's brake circuit of vehicle equipped with ATC. Active braking valves allows the system to apply pressure to slow the drive wheel if the wheel starts to spin. A faulty ABV usually illuminates dashboard lights for the ABS or ATC systems and the system will likely not function properly. Troubleshooting active braking valves require skills in electrical testing that include checking the active braking valves solenoid for resistance, checking the ECU harness and active braking valves solenoid together for resistance, verifying no change in resistance or open circuit between active braking valves and through harness and checking harness for any shorts to battery and shorts to ground. According to Wabco (2019), measurements should read as follows: at active braking valves supply to common, 7.0-14.0 ohms for 12V system 26.3-49.0 ohms for 24V system and at ECU harness pins with active braking valves connected, 7.0-14.0 ohms for 12V system 26.3-49.0 ohms for 24V system (no more than 1-ohms difference is okay).

### **2.8.1 Contents for Troubleshooting Active Brake Valve**

- i. Check ABV 3/2 solenoid for resistance
- ii. Check ECU harness and active brake valve 3/2 solenoid together for resistance
- iii. Verify no change in resistance or open circuit between active brake valve and through harness
- iv. Check harness for any shorts to battery and shorts to ground
- v. Ensure measurement at active brake valve reads 7.0-14.0

- ohms for 12V system
- vi. Ensure measurement at active brake valve reads 26.3-49.0 ohms for 24V system
  - vii. Ensure measurement at ECU harness pins with active brake valve connected reads 7.0-14.0 ohms for 12V system
  - viii. Ensure no continuity at ECU harness for battery voltage or ground

## **2.9 Troubleshooting Electronic Stability Control Module**

The electronic stability control module is a control unit that is considered as the processor and the brain of the entire ESC. It receives voltage, earth and CAN communication from the ECU. The information generated by the installed sensors of the ESC system, such as the wheel speed, lateral acceleration, yaw and steering angle sensors, is received by the electronic stability control module. Jung *et al.* (2010) noted that, the ESC module then utilizes this data, processes it and generates the electronic signals to ensure that the vehicle's ESC system effectively prevent the vehicle from losing the traction and remain stable on the roads. ESC light will illuminate on the vehicle's dashboard if the module is not working properly. According to Kristen (2019), all of the ECU connectors must be plugged in as well as the SAS and do not load test across power and earth at the ESC module when troubleshooting. Troubleshooting ESC module require skills in electrical testing that include taking measurements at the ESC module harness connector (Figure 2.4), measuring voltage supply, CAN high voltage and CAN low voltage with key on. Josh (2018) noted that, troubleshooting ESC module require measuring terminating resistance across CAN high and low with key Off. Nevertheless, with ECU and ESC module disconnected:

verify continuity end to end on each line, no shorts to ground or battery on all lines and no continuity between pins. Wabco (2019) disclosed that, when troubleshooting ESC module, measurements should read as indicated in Table 2.3.

**Table 2.3: Electronic Stability Control Module Circuit and Measurement**

<b>Pin</b>	<b>Circuit</b>	<b>Measurement</b>
1	Voltage Supply to Chassis Ground	8.0-16.0V
2	(Frame-mounted only) ESC Ground to Chassis Ground	Less than 1 ohms resistance
2	(Cab-mounted only) ESC Ground	Should have continuity but will not be less than 1 ohms
3 and 4	Terminating Resistance between ESC CAN-High to ESC CAN-Low	Approximately 90 ohms
1	With ECU disconnected, check power supply for battery voltage or ground.	No continuity
2	With ECU disconnected, check ground for battery voltage or ground.	No continuity
3 and 4	With ECU disconnected, check CAN lines for battery voltage or ground.	No continuity
3	CAN High Voltage to Chassis Ground	2.5-5.0V
4	CAN Low Voltage to Chassis Ground	0.1-2.4V

**Source:** Wabco (2019)

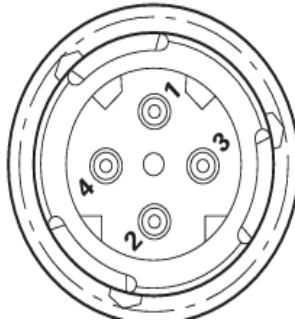

**Figure 2.4: Electronic Stability Control Module Connector**

**Source:** Kristen (2019)

### **2.9.1 Contents for Troubleshooting Electronic Stability Control Module**

- i. Do not load test across power and ground at the ESC Module
- ii. ECU connectors must be plugged in when testing resistance and voltage on ESC module
- iii. ECU connectors must be unplugged when testing continuity and short on ESC module
- iv. Take measurements at the ESC module harness connector
- v. Measure voltage supply with key on
- vi. Measure Communication Area Network (CAN) high voltage with key on
- vii. Measure CAN high voltage with key on
- viii. Measure terminating resistance across CAN high and low with key off
- ix. Verify continuity end to end on each line with ECU and ESC module disconnected
- x. Verify no shorts to ground or battery on all lines with

ECU and ESC module disconnected

- xi. Verify no continuity between pins with ECU and ESC module disconnected
- xii. Ensure Voltage Supply to Chassis Ground at pin 1 reads 8.0-16.0V
- xiii. Ensure ESC ground to chassis ground at pin 2 reads less than 1 ohms resistance
- xiv. Ensure terminating resistance between ESC CAN-high to ESC CAN-low (pin 3 and 4) reads approximately 90 ohms
- xv. With ECU disconnected, check power supply for battery voltage or ground at pin 1 and 2 and ensure no continuity
- xvi. With ECU disconnected, check CAN lines for battery voltage or ground at pin 3 and 4 and ensure no continuity
- xvii. Ensure CAN high voltage to chassis ground at pin 3 reads 2.5-5.0V
- xviii. Ensure CAN low voltage to chassis ground at pin 4 reads 0.1-2.4V
- xix. Ensure that ESC harnesses are connected

## **2.10 Troubleshooting Steering Angle Sensor**

The steering angle sensor reports the position of the steering wheel (where the driver wants to go) and how fast the steering wheel is being turned. The common failure on ESC is a failed steering angle sensor. ESC light generally illuminates on dashboard if steering angle sensor is malfunctioning. Troubleshooting steering angle sensor require disconnecting and check the terminating resistance across pin 1 and pin 2 of the sensor connector as shown in Figure 2.5. Nyberg and Frisk

(2015) revealed that, troubleshooting steering angle sensor include taking measurements at the harness connector side by checking CAN low voltage on pin 1, CAN high voltage on pin 4 and voltage supply on pin 5 with Key On as well as checking resistance across CAN low pin 1 and CAN high pin 4 with Key Off while the ECU and ESC module connectors must be plugged in as the ECU provides all voltage, ground and CAN communications. Wabco (2019) disclosed that, when troubleshooting steering angle sensor, measurements should read as indicated in Table 2.4.

**Table 2.4: Steering Angle Sensor Location and Measurements**

<b>Location</b>	<b>Measurement</b>
SAS terminating resistor on sensor	Approximately 180 ohms
CAN High Voltage	2.5-5.0V
CAN Low Voltage	0.1-2.4V
Voltage Supply to Ground	8.0-16.0V
ESC CAN-High to ESC CAN-Low	Approximately 90 ohms
Steering angle sensor harness jumper (Pin 2 to Pin 4 or Pin 2 to Pin 3)	Continuity
ESC CAN-High or CAN-Low to Power or Ground (with ECU, ESC Module and SAS unplugged)	No continuity

**Source:** Wabco (2019)

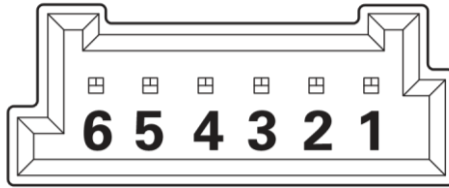

**Figure 2.5: Steering Angle Sensor Connector**

**Source:** Kristen (2019)

### **2.10.1 Contents for Troubleshooting Steering Angle Sensor**

- i. ECU and ESC module connectors must be plugged in when testing steering angle sensor connector for voltage
- ii. Do not load test across power and ground at the steering angle sensor
- iii. Disconnect steering angle sensor and check terminating resistance across Pin 1 and Pin 2
- iv. Take measurements at the steering angle sensor harness connector side
- v. With key on, check CAN low voltage on pin 1
- vi. With key on, check CAN high voltage on pin 4
- vii. With key on, check voltage supply on Pin 5
- viii. With key off, check resistance across CAN low Pin 1 and CAN high Pin 4
- ix. Ensure measurement at steering angle sensor terminating resistor reads approximately 180 ohms
- x. Ensure measurement at CAN high voltage reads 2.5-5.0V



- xi. Ensure measurement at CAN low voltage reads 0.1-2.4V
- xii. Ensure voltage supply to ground reads 8.0-16.0V
- xiii. Ensure measurement at ESC CAN-high to ESC CAN-low reads approximately 90 ohms
- xiv. Ensure continuity at steering angle sensor harness jumper (Pin 2 to Pin 4 or Pin 2 to Pin 3)
- xv. Ensure no continuity at ESC CAN-high or CAN-low to power or ground (with ECU, ESC Module and steering angle sensor unplugged)

### **2.11 Troubleshooting Yaw Rate Sensor**

The yaw rate sensor is an electrical component that is stored either in the vehicle's ECU or under the dashboard near the fuse box. It's not commonly subject to wear and tear, and most issues with this device are attributed to problems with one of the three individual sensors it monitors. Stephen (2016) noted that, there are a few warning signs you might recognize when the yaw rate sensor begins to fail that include Malfunction Indicator Lamp (MIL) comes on and ESC or ATC lights illuminate. Troubleshooting yaw rate sensor require checking the CAN bus line for disconnection by turning the ignition switch to the lock position, disconnecting the yaw rate sensor connector (as shown in Figure 2.6) from the yaw rate sensor. According to Toyota (2015), measurements of resistance and voltage in troubleshooting ECU circuit should read as shown in table 2.5.

**Table 2.5: Yaw Rate Sensor Connector Pin, Condition and Measurements**

<b>Pin</b>	<b>Condition</b>	<b>Measurements</b>
2 (CAN Low)	Ignition switch Off	54 to 69 ohms
3 (CAN High)	Ignition switch Off	54 to 69
1 (GND) -Body ground	Always	Below 1 ohms
5 (IG) - Body ground	Ignition switch On	10 to 14 V

**Source:** Toyota (2015)

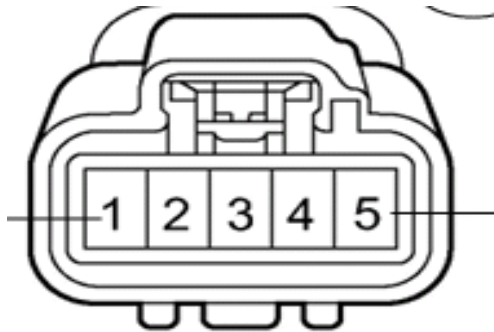

**Figure 2.6: Yaw Rate Sensor Connector**

**Source:** Toyota (2015)

### **2.11.1 Contents for Troubleshooting Yaw Rate Sensor**

- i. Take measurements at the yaw rate sensor connector
- ii. Disconnect the yaw rate sensor connector
- iii. Take measurements at the yaw rate sensor connector
- iv. With key off, check CAN low resistance on pin 2
- v. With key off, check CAN high resistance on pin 3
- vi. With key on/off, check body ground resistance on Pin 1

- vii. With key on, check body ground voltage on Pin 5
- viii. Ensure measurement at CAN low resistance reads 54 to 69 ohms
- ix. Ensure measurement at CAN high resistance reads 54 to 69 ohms
- x. Ensure measurement at body ground resistance reads less than 1 ohms
- xi. Ensure measurement at body ground voltage reads 10 to 14 V

## **2.12 Troubleshooting Lateral Acceleration Sensor**

The lateral acceleration sensor provides a signal based on the lateral or side force presented on the vehicle through the curve. The sensor has a fixed electrode and a movable electrode that changes the capacitance of the sensor when laterally loaded. Mohamad (2019) confirmed that, lateral acceleration sensors have been known to fail, and when they do, MIL, ESC and even ABS lights illuminates. Troubleshooting lateral acceleration sensor involve checking fuses that that power up the sensor. Reinier (2016) stated that, troubleshooting lateral acceleration sensor involve disconnecting the negative battery cable before unplugging the sensor connector (as shown on Figure 2.7), make voltage and the two communication circuits checks. Randy (2019) further noted that, measurements in troubleshooting lateral acceleration sensor should read as 2.6 volts at CAN high (pin 1) and 2.4 volts at CAN low (pin 3) with the car's Key On but engine Off.

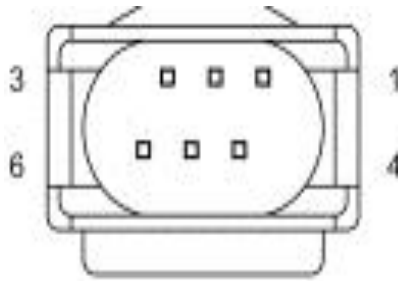

**Figure 2.7: Lateral Acceleration Sensor 6 Way Connector**

**Source:** Autozone (2019)

### **2.12.1 Contents for Troubleshooting Lateral Acceleration Sensor**

- i. Check fuses that power up the sensor
- ii. Unplug the sensor connector
- iii. Take measurements at the lateral acceleration sensor connector
- iv. With key on, check CAN high voltage on pin 1
- v. With key on, check CAN low voltage on pin 3
- vi. Ensure measurement at volts at CAN high (pin 1) voltage reads 2.6 volts
- vii. Ensure measurement at volts at CAN low (pin 3) voltage reads 2.4 volts
- viii. Ensure no short to the ground

# CHAPTER THREE

## ELECTRONIC BRAKING SYSTEMS MAINTENANCE

### 3.0 Objectives

By the end of studying this chapter, automobile craftsmen should be able to effectively carry out the maintenance of electronic braking systems components that include: wheel speed sensor, Electronic Control Unit (ECU), modulator valve, brake pressure sensor, active brake valve, Electronic Stability Module (ECM) and steering angle, yaw rate and lateral sensors.

### 3.1 Concept of Maintenance

Maintenance is a way of repairing or servicing used equipment or machine in order to make for enhanced functioning capacity. Ugwu *et al.* (2018) defined maintenance as every action taken to preserve an infrastructure in its original state so that it will retain its economic value and durability. Maintenance is the combination of all scientific, technical and managerial actions during the life cycle of an item intended to retain it in, or restore it to a state in which it can perform the required function (Eti *et al.*, 2016). Cîmpan *et al.* (2013) argued that, the maintenance of modern automobiles especially those equipped with electronic braking systems is the most challenging task in automobile maintenance industry. The consequences of operational failure of electronic braking systems may result to fatal accident and loss of resources. Tashtoush *et al.* (2010) also stressed that, despite the importance of electronic braking systems, car owners are stripped of the full benefits attached to the systems due to lack of

effective maintenance skills among automobile craftsmen.

**Table 3.1: Facilities for the Maintenance of Electronic Braking Systems and their Uses**

S/N	Facilities	Uses
1	Allen key	For driving bolts and screws with a hexagonal socket on the ECU harness and modulator valve
2	1/2 inch metric and standard sockets	For tightening and loosening nuts and bolts of 14mm, 15mm, 16mm and 17mm standard sizes
3	3/8 inch metric and standard sockets	For tightening and loosening nuts and bolts of 11mm, 12mm, 13mm and 14mm standard sizes
4	1/4 inch metric and standard sockets	For tightening and loosening nuts and bolts of 8mm, 9mm, 10mm and 11mm standard sizes
5	Pry bars	To pull hubs from their location
6	Jack	To lift the vehicle up and put it on jack stands
7	Jack stand	To keep the vehicle firmly suspended from the ground
8	Torque wrench	To remove the bolt that holds the sensor onto the hub/knuckle
9	Assorted screw driver	To screw and unscrew the screws that hold the ECU and its harness
10	Wheel socket	To remove and place the road wheels
11	Assorted plier	To remove any clips or hold downs that are securing the sensor wiring to the vehicle's chassis/body

<b>S/N</b>	<b>Facilities</b>	<b>Uses</b>
12	Emery cloth or sandpaper	To clean off any rust in the areas where the new sensor will be going to ensure it fits easily
13	Disposable gloves	For hand protection against any sharp edges
14	Brass hammer	To install insert the hub/knuckle
15	Shop rag	To clean any surface from unwanted contents
16	Flat screwdriver	For screwing (installing) and unscrewing (removing) screws with flat head on ECU and ECU harness
17	Phillip screwdriver	For screwing (installing) and unscrewing (removing) screws with Phillip head on ECU and ECU harness
18	A torque screw set	To ensure tightening to a specified torque
19	Blower	To blow away unwanted deposit in the ECU and sensors
20	Alcohol or cleaner	For cleaning ECU to avoid malfunctioning due to dust deposit
21	Combination wrenches	Are used for Tightening/loosening nuts and bolts
22	Floor mats	To provide the craftsmen with the comfort and safety while working to remove wheel hub, speed sensor among others
23	Dental pick	To remove deposit and lift sensor from position
24	Safety glasses	To prevent eyes damage while blowing or cleaning ECU with alcohol

S/N	Facilities	Uses
25	Steering wheel puller kit	To uninstall the steering wheel from position
26	Slip joint pliers	For removing pins holding sensors
27	Snap ring pliers	For removing snap rings from steering collar

**Source:** Author

### 3.2. Wheel Speed Sensor Maintenance

The wheel speed sensor is also referred to as an ABS sensor, is attached to the hub of a wheel as shown in Figure 3.1. A failing wheel speed sensor commonly impact the operation of ABS, ATC and ESC systems and display certain warning signs that any driver can instantly notice as they drive.

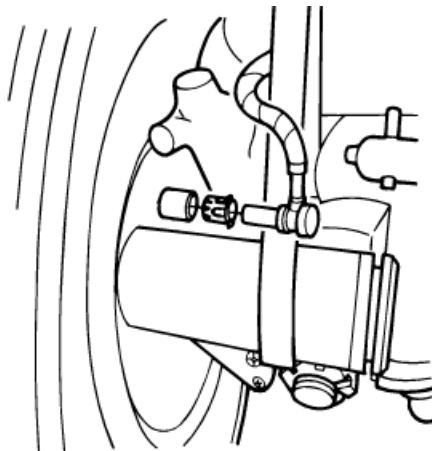
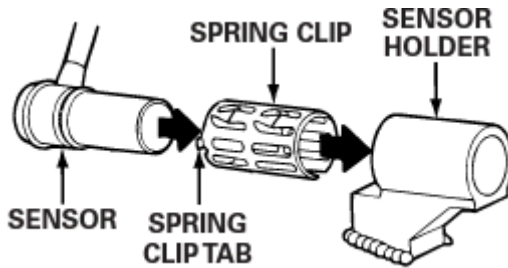

**Figure 3.1: Location of Wheel Speed Sensor**

**Source:** Wabco (2019)



The maintenance of wheel speed sensor involves removing, cleaning, replacing and installing the sensor. Larry (2019) stated that, replacement a wheel speed sensor involves jacking the vehicle up, removing the wheels, putting it on axle stands, disconnecting the fasteners that hold the sensor cable to other components, the sensor cable from the chassis harness and removing the sensor from the sensor holder and spring clip (as shown in Figure 3.2).



**Figure 3.2: Wheel Speed Sensor, Holder and Spring Clip**

**Source:** Wabco (2019)

After removing the wheel speed sensor, cleaning and application of recommended lubricant to the sensor spring clip and sensor or replacement is necessary during maintenance. Nevertheless, Chris (2016) revealed that, installing or assembling a wheel speed sensor involve connecting the sensor cable to the chassis harness, installing the fasteners used to hold the sensor cable and spring clip in place as well as pushing the sensor completely into the sensor spring clip until it contacts the tooth wheel. Finally, other tasks include, placing the wheels back onto the hubs, jacking the vehicle back off the axle stands and test drive the vehicle.

### **3.2.1 Facilities for the Maintenance of Wheel Speed Sensor:**

- i. Allen sets (metric and standard sockets)
- ii. Assorted pliers
- iii. Assorted screwdrivers
- iv. Breaker bar (½ inch drive)
- v. Brass hammer
- vi. Combination wrench set, metric and standard
- vii. Disposable gloves
- viii. Emery cloth/sandpaper
- ix. Flashlight
- x. Floor jack and jack stands
- xi. Metric and standard socket set (½ inch drive)
- xii. Pry bar
- xiii. Ratchet (? drive)
- xiv. Socket set (metric and standard ? drive)
- xv. Socket set (metric and standard ¼ drive)
- xvi. Torque wrench (? or ½ drive)
- xvii. Torque socket set
- xviii. Wheel socket set (½ inch drive)
- xix. Contents for the Maintenance of Wheel Speed Sensor
- xx. Park the vehicle on a level surface
- xxi. Wedge the wheels to prevent the vehicle from moving
- xxii. Apply the parking brake
- xxiii. Jack the vehicle up
- xxiv. Put the vehicle on axle stands

- xxv. Remove the road wheels
- xxvi. Disconnect the fasteners that hold the sensor cable to other components
- xxvii. Disconnect the sensor cable from the chassis harness
- xxviii. Remove the sensor from the sensor holder
- xxix. Remove the sensor spring clip
- xxx. Clean the sensor
- xxxi. Apply a recommended lubricant to the sensor spring clip and sensor
- xxxii. Replace the sensor (if necessary)
- xxxiii. Connect the sensor cable to the chassis harness
- xxxiv. Install the fasteners used to hold the sensor cable in place
- xxxv. Install the sensor spring clip
- xxxvi. Push the sensor spring clip into the bushing in the steering knuckle until the clip stops
- xxxvii. Push the sensor completely into the sensor spring clip until it contacts the tooth wheel
- xxxviii. Place the road wheels back onto the hubs
- xxxix. Remove the safety stands
- xl. Torque the wheels
- xli. Jack the vehicle back off the jack stands
- xlii. Test drive the vehicle

### **3.3 Electronic Control Unit Maintenance**

A faulty ECU illuminates ABS, ATC and ESC lights on the dashboard and render virtually all the electronic systems including ABS, ATC and ESC as well as the automobile functionality inactive. Valerie (2016) noted that, wearing rubber gloves reduces the chances of static discharge when maintaining ECU. The maintenance of ECU module involves removing, cleaning, replacing and installing fuses and other harnesses of the ECU. The replacement of ECU involves parking the vehicle on a levelled surface. Keep the emergency brakes on, disconnecting the battery or remove the cable from the negative terminal, locating the ECU, removing all the connectors, screws and any ties that mounts the unit and removing the ECU. According to Josh (2018a), it is necessary to match the old ECU with the new one and clean the mounting surface properly when installing the replacement of ECU. Nevertheless, Jitesh (2014) noted that, installing the ECU involve placing the new module carefully, connecting the wires and other electrical connections, reconnecting the battery to turn on the connection.

#### **3.3.1 Facilities for the Maintenance of Electronic Control Unit:**

- i. Shop clean rags
- ii. ECU replacement
- iii. Torque screw set
- iv. Screwdriver(s) (flat)
- v. Screwdriver(s) (Phillips head)
- vi. Socket set
- vii. Ratchet

### **3.3.2 Contents for the Maintenance of Electronic Control Unit (ECU)**

- i. Apply the parking brake
- ii. Disconnect the battery or remove the cable from the negative terminal
- iii. Locate the ECU (usually on the bonnet)
- iv. Remove all the ECU connectors
- v. Remove screws and any ties that mounts the unit
- vi. Remove the ECU
- vii. Clean the ECU
- viii. Carry out physical checks
- ix. Replace the ECU (if necessary)
- x. Match the old ECU with the new one
- xi. Clean the mounting surface properly when installing the replaced ECU
- xii. Place the new module carefully
- xiii. Connect the wires and other electrical connections to the ECU
- xiv. Reconnect the battery
- xv. Turn on the connection

### **3.4 Pressure Modulator Valves Maintenance**

A pressure modulator valve controls air pressure to an affected wheel-end brake during an ABS, ATC or ESC event to reduce speed and prevent wheel lock up. A faulty pressure modulator valve usually illuminates dashboard lights for the ABS or ATC systems and the system will likely not function properly. The maintenance of pressure modulator valve involves removing,

cleaning, replacing and installing the valve. According to Wong (2015), the replacement of pressure modulator valve involves the following stages: turning the ignition switch to the Off position, application of parking brake, raising the vehicle off the ground and place safety stands under the axle, disconnecting the wiring connector from the valve and the air lines from Ports 1 (air supply) and 2 (air discharge) of the valve (as shown in Figure 3.3) as well as removing the two mounting cap screws and nuts and the valve.

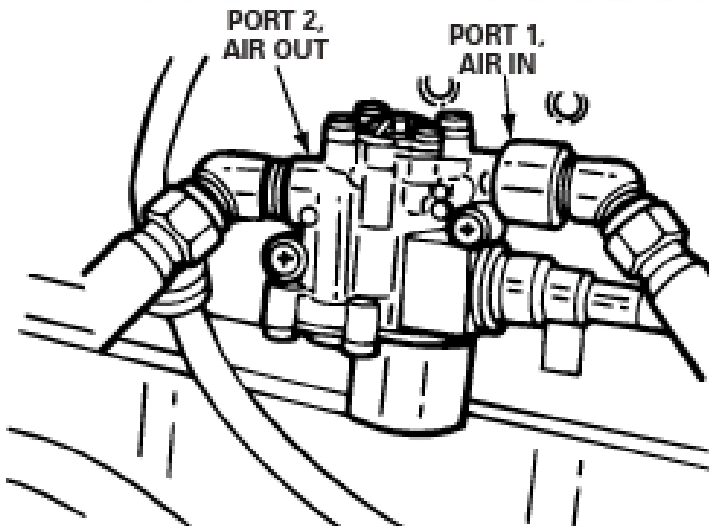

**Figure 3.3: Pressure Modulator Valve Ports to be Disconnected**

**Source:** Wabco (2019)

After removing the pressure modulator valve, cleaning and ensuring no physical damage is made on the valve or replacement is necessary during maintenance. Nevertheless, Ignizio (2017) noted that, the assembling or installation of pressure modulator valve involve mounting the two cap screws

and nuts, tightening the cap screws per the manufacturer's recommendation, connecting the line to the brake chambers to Port 2, the air supply line to Port 1 and the wiring connector to the valve. Furthermore, other tasks include, removing the axle stands, testing the installation by turning the ignition on, applying the brakes and listening for leaks and cycle of the modulator valve. Meineke (2017) noted that, if the valve fails to cycle, check the electrical cable connection, make repairs or replacement as needed and test drive the vehicle.

### **3.4.1 Facilities for the Maintenance of Pressure Modulator Valves:**

- i. Screwdriver(s) flat
- ii. Screwdriver(s) Phillips head
- iii. Plastic sheet or rubber mat
- iv. Replacement of pressure modulator and active braking valves
- v. Rubber gloves
- vi. Socket set
- vii. Ratchet
- viii. Wrenches-open/box-end
- ix. Blower
- x. Clean microfiber cloth
- xi. Alcohol or cleaner

### **3.4.2 Contents for the Maintenance of Pressure Modulator Valves**

- i. Park the vehicle on a level surface
- ii. Turn the ignition switch Off
- iii. Apply the parking brake
- iv. Wedge the wheels to prevent the vehicle from moving
- v. Jack the vehicle up
- vi. Put the vehicle on axle stands
- vii. Locate the pressure modulator valves
- viii. Disconnect the wiring connector from the pressure modulator valves
- ix. Disconnect the air lines from Ports 1 (air supply) and 2 (air discharge) of the ABS valve
- x. Remove the two mounting cap screws and nuts
- xi. Remove the pressure modulator valves
- xii. Clean the pressure modulator valves
- xiii. Check for damages
- xiv. Make repairs as needed
- xv. Replace the pressure modulator valves (if necessary)
- xvi. Install the pressure modulator valves with two mounting cap screws and nuts
- xvii. Tighten the cap screws to the manufacturer's recommendation
- xviii. Connect the line to the brake chambers to Port 2 of the pressure modulator valves
- xix. Connect the air supply line to Port 1 of the pressure modulator valves
- xx. Connect the wiring connector to the pressure modulator



valves (hand tighten only)

- xxi. Remove the stands
- xxii. Test the installation by applying the brake pedal
- xxiii. Observe for leaks at the pressure modulator valve
- xxiv. Turn the ignition on and listen to the modulator valve cycle
- xxv. If the valve fails to cycle, check the electrical cable connection
- xxvi. Verify that the ABS indicator lamp operates correctly

### **3.5 Brake Pressure Sensor Maintenance**

The common failures on an ABS is a failed brake pressure sensor. When brake pressure sensor fail, ABS, ATC and ESC light generally illuminates on dashboard and there are physical braking issues that manifests wheel locking during braking. The maintenance of brake pressure sensor involves removing, cleaning, replacing and installing the sensor. According to Thompson (2016), the typical steps for replacing the brake pressure sensor on most current passenger vehicles include, locating the brake pressure sensor usually found mounted near the brake master cylinder, unplugging the electrical connector (as shown in Plate I) and removing the brake pressure sensor.



**Plate I: Unplugging the Electrical Connector of Brake Pressure Sensor**

**Source:** Thompson (2016)

Nevertheless, installing the brake pressure sensor involve threading the replacement into place, tightening the sensor as far as possible by hand, plugging electrical connector. Josh (2018b) disclosed that, verifying the installation of the brake pressure sensor involve refilling the reservoir to the correct level if any fluid was lost during replacement, starting the vehicle and let it run for 10-15 seconds, pressing on the brake firmly a couple of times. Finally, test driving the vehicle to ensure that the ABS, ATC and ESC indicator lamp goes off.

**3.5.1 Facilities for the Maintenance of Brake Pressure Sensor:**

- i. Screwdriver(s) flat
- ii. Screwdriver(s) Phillips head
- iii. Shop towels/rags
- iv. Wrench set

### **3.5.2 Contents for the Maintenance of Brake Pressure Sensor**

- i. Park the vehicle on a level surface
- ii. Turn the ignition switch Off
- iii. Apply the parking brake
- iv. Locate the brake pressure sensor (usually found mounted near the brake master cylinder)
- v. Unplug the electrical connector
- vi. Remove the brake pressure sensor
- vii. Clean the brake pressure sensor
- viii. Check for damage
- ix. Replace the brake pressure sensor
- x. Thread the replacement into place
- xi. Tighten the sensor as far as possible by hand
- xii. Plug electrical connector
- xiii. Verify the installation of the brake pressure sensor
- xiv. Refill the reservoir to the correct level if any fluid was lost during replacement
- xv. Start the vehicle and let it run for 10-15 seconds
- xvi. Press on the brake firmly a couple of times
- xvii. Ensure that the ABS, ATC and ESC indicator lamp goes off

### **3.6 Active Braking Valves Maintenance**

Depending on the manufacturers' specifications and vehicle system configuration, active braking valves may be located near the rear axle, front axle and in line with control line. A faulty active braking valves usually illuminates dashboard lights for the

ATC systems and the system will likely not function properly. The maintenance of active braking valves involves removing, cleaning, replacing and installing the valve. According to Ciulla (2010), the replacement of active braking valves involves turning the ignition switch to the OFF position, application of parking brake, raising the vehicle off the ground and place safety stands under the axle, disconnecting the wiring connector from the valve and the air lines from Port 1 (air supply), Port 2 (air discharge) and Port 3 (treadle) of the ATC valve (as shown in Figure 3.4) as well as removing the two mounting caps crews and nuts and the valve.

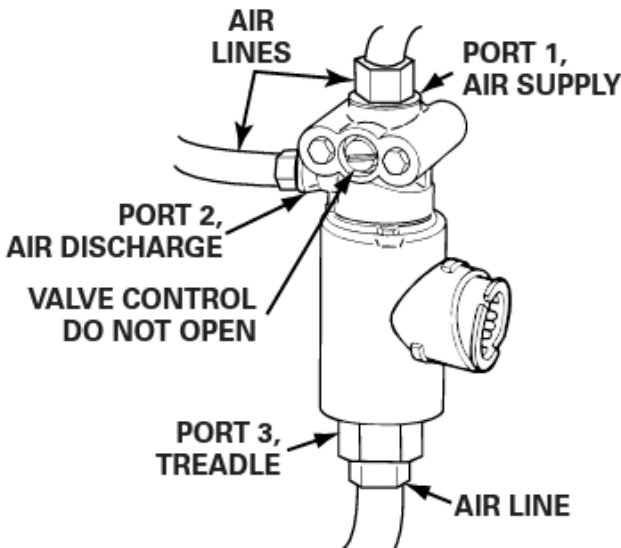

**Figure 3.4: Active Braking Valves Ports to be Disconnected**

**Source:** Wabco (2019)

After removing the active braking valves, cleaning and ensuring no physical damage is made on the valve or replacement is necessary during maintenance. Nevertheless, the assembling or

installation of active braking valves involve mounting the two cap screws and nuts, tightening the cap screws per the manufacturer's recommendation, connecting the air supply, discharge and treadle lines to Ports 1, 2 and 3 of the valve and the harness connector to the valve. Furthermore, other tasks include, removing the axle stands, testing the installation. Kiyotaka *et al.* (2010) disclosed that, testing the installation of active braking valves involve turning the engine fully charging the reservoirs with air, shutting off the vehicle, applying the brakes, listening for air leaks at the valve and releasing the brakes. Finally, other tasks include, verifying correct operation and that there are no active codes, making necessary replacement if needed, test driving the vehicle to ensure that the ATC indicator lamp goes off.

### **3.6.1 Facilities for the Maintenance of Active Braking Valves:**

- i. Screwdriver(s) flat
- ii. Screwdriver(s) Phillips head
- iii. Plastic sheet or rubber mat
- iv. Replacement of pressure modulator and active braking valves
- v. Rubber gloves
- vi. Socket set
- vii. Ratchet
- viii. Wrenches-open/box-end
- ix. Blower
- x. Clean microfiber cloth
- xi. Alcohol or cleaner

### **3.6.2 Contents for the Maintenance of Active Braking Valves:**

- i. Park the vehicle on a level surface
- ii. Turn the ignition switch Off
- iii. Apply the parking brake
- iv. Wedge the wheels to prevent the vehicle from moving
- v. Jack the vehicle up
- vi. Locate active braking valves near the rear axle or front axle
- vii. Disconnect the wiring from the valve
- viii. Remove the two mounting cap screws and nuts
- ix. Disconnect the air lines from Port 1 (air supply), Port 2 (air discharge) and Port 3 (treadle) of the active braking valves
- x. Remove the active braking valves
- xi. Clean the active braking valves
- xii. Check for damages
- xiii. Make repairs as needed
- xiv. Replace the active braking valves (if necessary)
- xv. Install the valve with two mounting cap screws and nuts
- xvi. Tighten the cap screws based on manufacturer's recommendation
- xvii. Connect the air supply, discharge and treadle lines to Ports 1, 2 and 3 of the valve
- xviii. Connect the harness connector to the valve (hand tighten only)
- xix. Remove the stands

- xx. Turn the ignition to the on position
- xxi. Verify that the ATC/ESC lamp operates correctly
- xxii. Start the vehicle
- xxiii. Fully charge the reservoirs with air
- xxiv. Shut off the vehicle
- xxv. Apply the brakes
- xxvi. Observe for air leaks at the valve
- xxvii. Release the brakes
- xxviii. Verify correct operation and that there are no active codes
- xxix. Verify that, the ATC indicator lamp operates correctly

### **3.7 Electronic Stability Control Module Maintenance**

A faulty ESC module illuminates ESC lights on the dashboard and render the systems non-functional. According to Wabco (2019), verifying the ESC module to ensure is correctly leveled and securely mounted and not moving the module to a different location as this will affect the system performance are precautions to be adhered to in the maintenance of ESC module. The maintenance of ESC module involves removing, replacing and installing as the case may be. Replacing the ESC module involve turning the ignition switch to the Off position, applying the parking brake, placing blocks under the front and rear tires to prevent the vehicle from moving, locating the ESC module, disconnecting the wiring harness connector from the module removing the two mounting caps crews and nuts and removing the ESC module. Ronny (2016) noted that, it is important that the module is aligned correctly and the tab on the ESC mounting surface fits into the appropriate hole. Nevertheless, installing the

ESC module involve returning the two cap screws and nuts, tightening the cap screws connecting the wiring harness connector to the ESC module, removing the stands and blocks and testing the installation by calibration. Finally, when the calibration procedure is completed, the ABS, ATC or ESC lamps should come on and go back off when ignition power is turned on.

### **3.7.1 Facilities for the Maintenance of Electronic Stability Control Module:**

- i. Shop clean rags
- ii. ECU replacement
- iii. Torque screw set
- iv. Screwdriver(s) flat
- v. Screwdriver(s) Phillips head
- vi. Socket set
- vii. Ratchet

### **3.7.2 Contents for the Maintenance of Electronic Stability Control Module:**

- i. Turn the ignition switch Off
- ii. Apply the parking brake
- iii. Wedge the wheels to prevent the vehicle from moving
- iv. Jack the vehicle up
- v. Locate the ESC module
- vi. Disconnect the wiring harness connector from the ESC module
- vii. Remove the two mounting cap screws and nuts



- viii. Remove the ESC module
- ix. Check for damages
- x. Clean the ESC module
- xi. Replace the ESC module (if necessary)
- xii. Install the ESC module with the two cap screws and nuts
- xiii. Tighten the cap screws per the manufacturer's recommendation
- xiv. Connect the wiring harness connector to the ESC module (hand tighten only)
- xv. Remove the wedge
- xvi. Test the installation
- xvii. Calibrate the system
- xviii. The ABS and ATC/ESC lamps should come on and go back off when ignition power is turned on

### **3.8 Steering Angle Sensors Maintenance**

The steering angle sensor finds a disparity between the course your vehicle is traveling and the position the steering wheel is held at and send signal to the ESC module to balances out the steering and puts the driver in more control. According to Marvin (2016), if the steering angle sensor is not working, the ATC and ESC lights illuminates, the steering wheel feeling loose and the car driving differently after a front end alignment. The maintenance of steering angle sensor involves removing, cleaning, replacing and installing the sensors. Robert (2015) disclosed that, it is necessary to disable the supplemental restraint system (air bag) to avoid serious personal injury during steering angle sensor maintenance. Removing of steering angle sensor

involve turning the ignition switch to the Off position, applying the parking brake, placing blocks under the front and rear tires to prevent the vehicle from moving, locating the sensor on the steering column shaft (as shown in Plate II), disconnecting the wiring harness connector removing three screws attached to the steering column, and slide the sensor off of the steering column shaft.



**Plate II: Location of the Steering Angle Sensor on Steering Column Shaft**

**Source:** Marvin (2016)

Nevertheless, after removing the steering angle sensor, cleaning, checking for damage, application of small amount of grease to the tab in the center of the sensor or replacement is necessary during maintenance. Nevertheless, Chris (2016) revealed that, if the steering angle sensor is not installed in the correct orientation, it will not function correctly and may become damaged. Installing or assembling a steering angle sensor involve connecting the sensor installing the sensor with the connector facing the same direction as the original, placing the sensor over

the steering column shaft and slide it into place replacing the attaching screws and tighten installing the sensor wiring harness connector by pushing the connector together until the small tab snaps. Furthermore, installing the steering wheel and tighten per the manufacturer's recommendation, removing the blocks and testing the installation by calibration. Finally, when the calibration procedure is completed, the ABS, ATC or ESC lamps should come on and go back off when ignition power is turned on.

### **3.8.1 Facilities for the Maintenance of Steering Angle Sensor:**

- i. Allen wrench set SAE/Metric
- ii. Boxed end wrenches
- iii. Cross tip screwdriver
- iv. Dental picks
- v. Flathead screwdriver
- vi. Protective gloves
- vii. Ratchet
- viii. Standard sockets
- ix. Safety glasses
- x. Slip joint pliers
- xi. Snap ring pliers
- xii. Steering wheel puller kit
- xiii. Torque bit set
- xiv. Wheel chocks

### **3.8.2 Contents for the Maintenance of Steering Angle Sensors:**

- i. Center the steering wheel with the front wheels positioned straight ahead
- ii. Turn the ignition switch Off
- iii. Apply the parking brake
- iv. Wedge the wheels to prevent the vehicle from moving
- v. Locate the steering angle sensors on the steering column shaft, either near the universal joint on the bottom of the column or under the steering wheel near the top of the column
- vi. Remove the vehicle steering wheel using the recommended steering wheel puller
- vii. Remove the three screws to the steering column with the center tab located in the grooved steering column shaft
- viii. Disconnect the wiring harness connector from the steering angle sensors (Note: the position of the connector either facing up or down.)
- ix. Remove the attaching screws
- x. Slide the steering angle sensors off of the steering column shaft
- xi. Remove the steering angle sensor
- xii. Clean the steering angle sensor
- xiii. Replace the steering angle sensors (if necessary)
- xiv. Apply a small amount of the supplied grease to the tab in the center of the steering angle sensor and to the machined groove on the steering shaft
- xv. Install the steering angle sensor with the connector

- facing the same direction as the original
- xvi. Place the steering angle sensor over the steering column shaft
  - xvii. Slide the steering column shaft into place with the steering angle sensor tab placed in the groove that is machined on the steering column shaft.
  - xviii. Replace the attaching screws
  - xix. tighten the screws in accordance to manufacturers' recommendations
  - xx. Install the steering angle sensor wiring harness connector
  - xxi. Install the steering wheel and tighten per the manufacturer's recommendation
  - xxii. Remove the wedge
  - xxiii. Test the installation
  - xxiv. Calibrate the system
  - xxv. The ABS and ATC/ESC lamps should come on and go back off when ignition power is turned on

### **3.9 Lateral Acceleration and Yaw Rate Sensors Maintenance**

The lateral acceleration and yaw rate sensors are designed to send information regarding the lateral or side force and tilt (the yaw) of vehicle to the ESC module to keep the vehicle within certain safety parameters. Faulty lateral acceleration and yaw rate sensors causes the ESC light to illuminate on dashboard and also causes physical stability issues. The maintenance of lateral acceleration and yaw rate sensors involve removing, cleaning, replacing and installing the sensors. According to Kenneth

(2016), the replacement of lateral acceleration and yaw rate sensors involve the following: disconnecting the negative battery cable, disabling air bag system, removing the seat mounting fastener and the front seat from the vehicle, disconnecting the electrical harness, unclipping the harness from the seat bracket, removing the yaw rate & lateral acceleration sensors mounting nuts (1), disconnecting the wiring harness connector (2) removing the yaw rate & lateral acceleration sensors (3) (as shown in Figure 3.5).

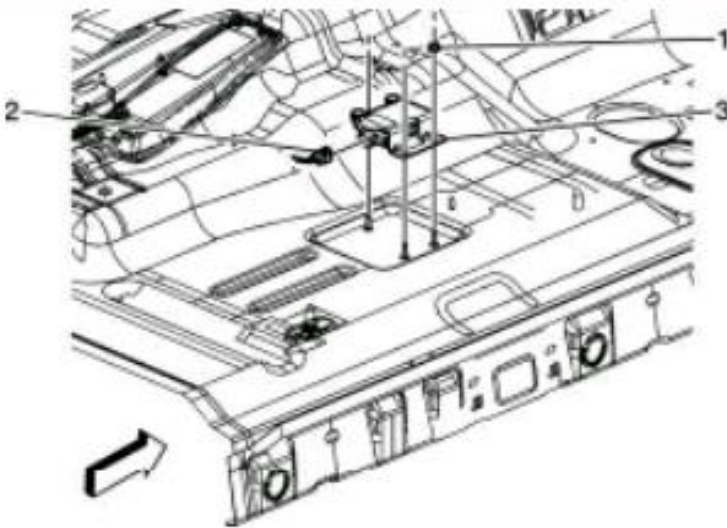

**Figure 3.5: Removing the Yaw Rate & Lateral Acceleration Sensor**

**Source:** Kenneth (2016)

Nevertheless, Envoy (2019) noted that, installing the yaw rate & lateral acceleration sensors involve connecting the wiring harness connector, installing the sensor mounting nuts and the seat to the vehicle, clipping the harness to the seat bracket, connecting the

electrical harness, enabling the air bag system, installing the seat mounting fastener covers and connecting the negative battery cable. Finally, ensure that, the ESC indicator lamp goes off.

### **3.9.1 Facilities for the Maintenance of Yaw Rate and Lateral Acceleration Sensors:**

- i. Allen set (metric & standard sockets)
- ii. Assorted pliers
- iii. Assorted screw drivers
- iv. Combination wrench set (metric & standard)
- v. Disposable gloves
- vi. Flashlight
- vii. Metric and standard wrench set
- viii. Pry bar
- ix. Ratchet (3/8 drive)
- x. Socket set (metric & standard 3/8 drive)
- xi. Socket set (metric & standard 1/4 drive)
- xii. Torque socket set

### **3.9.2 Contents for the Maintenance of Lateral Acceleration and Yaw Rate Sensors:**

- i. Turn the ignition switch Off
- ii. Apply the parking brake
- iii. Wedge the wheels to prevent the vehicle from moving
- iv. Disconnect the negative battery cable
- v. Disable air bag system
- vi. Remove the seat mounting fastener

- vii. Remove the front seat from the vehicle
- viii. Locate the yaw rate & lateral acceleration sensors
- ix. Disconnect the electrical harness
- x. Unclip the harness from the seat bracket
- xi. Remove the yaw rate & lateral acceleration sensors mounting nuts (1)
- xii. Disconnect the wiring harness connector (2)
- xiii. Remove the yaw rate & lateral acceleration sensors (3)
- xiv. Clean the yaw rate & lateral acceleration sensors
- xv. Replace the yaw rate & lateral acceleration sensors (if necessary)
- xvi. Install the yaw rate & lateral acceleration sensors
- xvii. Connect the wiring harness connector
- xviii. Install the sensor mounting nuts
- xix. Install the seat to the vehicle
- xx. Clip the harness to the seat bracket
- xxi. Connect the electrical harness
- xxii. Enable the air bag system
- xxiii. Install the seat mounting fastener covers
- xxiv. Connect the negative battery cable
- xxv. Ensure that, the ESC indicator lamp goes off



## REFERENCES

- Autozone. (2019). *Lateral acceleration sensor*. Retrieved 17<sup>th</sup> August, 2019 from: [https://www.autozone.com/repairguides/Crossfire-2006-2008/Connector-Pin-Charts-2007/ESP-Yaw-Rate-Lateral-Acceleration-Sensor-6-Way/\\_/P-0996b43f8075a9a3](https://www.autozone.com/repairguides/Crossfire-2006-2008/Connector-Pin-Charts-2007/ESP-Yaw-Rate-Lateral-Acceleration-Sensor-6-Way/_/P-0996b43f8075a9a3).
- Automotive System Engineering Study Guides. (2019). *Electronic stability control*. Retrieved 1<sup>st</sup> August, 2019 from: <https://www.freeasestudyguides.com/electronic-stability-control-esc.html>.
- Ayman A. A., El-ShafeiZeidan, A. H & Farhan, S. (2011). An antilock-braking systems (ABS) control: A technical review. *Intelligent Control and Automation*, 11(2), 186-195.
- Baek, S. H. & Jang, J. W. (2015). Implementation of integrated OBD-II connector with external network *Information System*, 8(50), 69–75.
- Bosch. (2019). *Electronic stability program*. Retrieved 1<sup>st</sup> August, 2019 from: <https://www.bosch-mobility-solutions.com/en/products-and-services/passenger-cars-and-light-commercial-vehicles/driving-safety-systems/electronic-stability-program/>
- Carley, L. (2019). *Antilock brakes*. Retrieved 28<sup>th</sup> July, 2019 from: <https://www.aalcar.com/library/abs1.htm>.
- Chankit, J., Rahul, A. & Abhishek, D. (2014). Linear control technique for anti-lock braking system. *Int. Journal of Engineering Research and Applications* 4(8), 321-328.
- Chris, Y. (2016). *How to replace a wheel speed sensor*. Retrieved 17<sup>th</sup> August, 2019 from:

<https://www.yourmechanic.com/article/how-to-replace-a-wheel-speed-sensor-by-chris-young>.

- Cîmpan, M., Vulcu, O. I. & Arghir, M. (2013). Maintenance technology of a turbomachine. 84th Annual Meeting GAMM 2013 March 18-22 Proceedings of International Conference. Yeppoon, Queensland, 196-201.
- Ciulla, V. (2010). *Your guide to auto repair, motor vehicle handbook*. New York, McGraw-Hill.
- Dang, J. N. (2017). *Statistical analysis of the effectiveness of electronic stability control (ESC) systems*. Washington, D.C.: National Highway Traffic Safety Administration, National Center for Statistics and Analysis.
- David, W. G. (2011). *Magneto resistive wheel speed sensors: New active wheel speed sensors changing ABS diagnostic procedures*. Retrieved 4<sup>th</sup> August, 2019 from: <http://www.asashop.org/autoinc/aug2011/mech.cfm>.
- Divyata, K. & Anjali, S. (2016). Antilock braking system and its advancement. *International Research Journal of Engineering and Technology (IRJET)*, 3(5), 2221-2229.
- Draganov, V. Vasileva, T. Traykov, B. (2007). Autotronics course: An innovative approach in automotive mechatronics education. *International virtual journal for science, techniques and innovations for the industry*, 5(8-9), 18-21.
- Envoy, R. (2019). *Anti-lock-brake system yaw rate lateral acceleration sensor*. Retrieved 17<sup>th</sup> August, 2019 from: [https://www.autozone.com/repairguides/Envoy-Rainer-Trailblazer-2006-2007/Anti-Lock-Brake-System/Yaw-Rate-Lateral-Acceleration-Sensor/\\_/P-](https://www.autozone.com/repairguides/Envoy-Rainer-Trailblazer-2006-2007/Anti-Lock-Brake-System/Yaw-Rate-Lateral-Acceleration-Sensor/_/P-).

- Eti, M. C., Ogaji, S. O. T., & Probert, S. D. (2016). Strategic maintenance management in Nigerian industries. *Applied Energy* 83(3), 211-227.
- Gillespie, T. D. (2013). *Fundamentals of vehicle dynamics*. Commonwealth Drive, Warrendale: Society of Automotive Engineers Inc.
- Hiroshi, F. & Shingo, H, (2015). Model-based range extension control system for electric vehicles with front and rear driving–braking force distributions. *IEEE Transactions on Industrial Electronics*, 62(5), 2225-2230.
- Ignizio, J. P. (2017). *Introduction to expert systems: The development and implementation of rule-based expert systems*. New York: McGraw-Hill.
- Jeff, T. (2017). *Understanding vehicle stability control*. Retrieved 17<sup>th</sup> August, 2019 from: <https://m.autoserviceprofessional.com/article/100319/understanding-vehicle-stability-control>.
- Jin, L. Q., Ling, M. & Yue, W. (2017). Tire-road friction estimation and traction control strategy for motorized electric vehicle. *International Journal of Automotive Technology*, 13(6), 743–750.
- Jitesh, S. (2014). Antilock braking system (ABS). *International Journal of Mechanical Engineering and Robotics Research*, 3(4), 112-117.
- Josh, K. (2018). *The functions and bad symptoms of electronic stability control in the car*. Retrieved 17<sup>th</sup> August, 2019 from: <https://oards.com/functions-and-bad-symptoms-of-electronic-stability-control/>.

- Josh, S. (2018a). *ABS control module symptoms function & replacement cost*. Retrieved 17<sup>th</sup> August, 2019 from: <https://mechanicbase.com/brakes/abs-control-module-symptoms/>.
- Josh, S. (2018b). *ABS sensor symptoms, function & location*. Retrieved 17<sup>th</sup> August, 2019 from: <https://mechanicbase.com/brakes/abs-sensor-symptoms/>.
- Jung, H., Kwak, B. & Papk, Y. (2010). Slip controller design for traction control system. *International Journal of Automobile Technology*, 1(3), 30–33.
- Kalwinder, K. (2013). *Lateral acceleration sensor*. Retrieved 2<sup>nd</sup> August, 2019 from: <https://www.azosensors.com/article.aspx?ArticleID=196>.
- Kawaguchi, M., Fujimoto, N., Katsumata, T. & Tanaka M. (2013). High accuracy yaw rate sensor for preventive safety system. Proceedings of the FISITA 2012 World Automotive Congress in China, 197.
- Kenneth, T. (2016). *How to replace a yaw rate sensor*. Retrieved 17<sup>th</sup> August, 2019 from: <https://www.autoblog.com/2016/11/17/how-to-replace-a-yaw-rate-sensor/>.
- Kia, N. (2017). *Electronic stability program system: Description and operation*. Retrieved 1<sup>st</sup> August, 2019 from: [www.kniro.net/description\\_and\\_operation-1402.html](http://www.kniro.net/description_and_operation-1402.html).
- Kiyotaka, K., Toshiyuki, U. & Yoichi, H. (2010). *Rolling stability control of in-wheel motor electric vehicle based on disturbance observer, motion control*. Retrieved 17<sup>th</sup> August, 2019 from: <http://www.intechopen.com/books/motion-control/rolling->

stability-control-of-inwheel-motor-electric-vehicle-based-on-disturbance-observer.

Koenning, M. & Heger, T. (2019). *Usage of surround sensor information for passive safety - Challenges and chances*. New York: Transportation Research Board.

Kristen, H. (2019). *How electronic stability control works*. Retrieved 1<sup>st</sup> August, 2019 from: <https://auto.howstuffworks.com/car-driving-safety/safety-regulatory-devices/electronic-stability-control1.htm>.

Larry, C. (2019). *Replacement of wheel speed sensor*. Retrieved 17<sup>th</sup> August, 2019 from: <https://www.aalcar.com/library/abs1.htm>.

Leonardo, R. G. (2019). *Use laptop automotive scan tool*. Retrieved 17<sup>th</sup> August, 2019 from: <https://itstillruns.com/use-laptop-automotive-scan-tool-5689214.html>.

Man, K. (2019). *Electronic stability control*. Retrieved 1<sup>st</sup> August, 2019 from: <https://www.bus.man.eu/de/en/man-world/technology-and-competence/safety-and-assistance-systems/electronic-braking-system/Electronic-braking-system.html>.

Marvin, S. (2016). *How to replace a steering angle sensor*. Retrieved 17<sup>th</sup> August, 2019 from: <https://www.yourmechanic.com/article/how-to-replace-a-steering-angle-sensor-by-marvin-sunderland>.

Matthew, H. & Rouse, M. (2018). *Troubleshooting*. Retrieved, 16<sup>th</sup> July, 2019 from: <https://whatis.techtarget.com/definition/troubleshooting>.

Meineke, J. (2017). *ABS brake service*. Retrieved 17<sup>th</sup> August, 2019

from: <https://www.meineke1.ca/services/abs-brakes-repair/>.

Michael, A. (2018). Modern automobile vehicle repair practices in micro, small and medium scale garages in Nigeria. *International Journal of Science, Technology and Society*, 2(6), 216-222.

Mohamad, A. (2019). *Lateral acceleration sensor*. Retrieved 17<sup>th</sup> August, 2019 from: <https://www.scribd.com/document/134653241/Lateral-Acceleration-Sensor>.

Nyberg, M. & Frisk, E. (2015). *Model based diagnosis of technical processes*. Sweden: Linköping.

Olathe, L. (2016). *All you ever wanted to know about vehicle stability control*. Retrieved 1<sup>st</sup> August, 2019 from: <https://parts.olathetoyota.com/vehicle-stability-control>.

Pack, R. (2015). *Pre-crash sensing countermeasures and benefits*. New York: Transportation Research Board.

Pawan, D. (2016). Road Safety and accident prevention in India: A review. *International Journal of Advanced Engineering Technology*, 2(3), 334-340.

Poursamad, A. (2009), Adaptive feedback linearization control of antilock braking system using neural networks. *Mechatronics*, 19(6), 767-773.

Ran, X. Zhao, X. & Chen, J. (2016). Novel coordinated algorithm for traction control system on split friction and slope road. *International Journal of Automotive Technology*, 17(5), 817-827.

Randy, W. (2019). *Lost communication with lateral acceleration sensor (LAS) module*. Retrieved 17<sup>th</sup> August, 2019 from:

<https://www.obd-codes.com/u0124>.

Reinier, L. (2016). *Data bus: lateral acceleration sensor module no communication*. Retrieved 17<sup>th</sup> August, 2019 from: <https://www.troublecodes.net/ucodes/u0124/>.

Robert, B. (2015). *Driving stability systems: Automotive technology, 1st ed.* Stuttgart: Bosch Inc.

Ronny, B. (2016). *How to replace a traction control module*. Retrieved 17<sup>th</sup> August, 2019 from: <https://www.autoblog.com/2016/10/19/how-to-replace-a-traction-control-module/>.

Seibum, B. C. (2018). Antilock brake system with a continuous wheel slip control to maximize the braking performance and the ride quality. *IEEE Transactions on Control Systems Technology*, 16(5), 116-120.

Shi, J., Li, X. & Lu, T. (2012). Development of a new traction control system for vehicles with automatic transmissions. *International Journal of Automobile Technology*, 5(13), 743–750

Standard Motor. (2019). *Yaw rate sensor*. Retrieved 2<sup>nd</sup> August, 2019 from: <https://www.standardbrand.com/en/products/sensors/sensors/yaw-rate-sensors>.

Stephen, J. (2016). *Symptoms of a bad or failing yaw rate sensor*. Retrieved 17<sup>th</sup> August, 2019 from: <https://www.autoblog.com/2016/01/13/symptoms-of-a-bad-or-failing-yaw-rate-sensor/>.

Tashtoush, G. M., Tashtoush, K. K., Al-Muhtaseb, M. A. & Mayyas, A. T. M. (2010). Reliability analysis of car

- maintenance scheduling and performance. *Jordan Journal of Mechanical and Industrial Engineering* 4(3), 388-393.
- Thompson, T. (2016). *How to replace anti-lock brake sensor on most modern cars*. Retrieved 17<sup>th</sup> August, 2019 from: <https://www.yourmechanic.com/article/how-to-replace-an-anti-lock-brake-pressure-switch-on-most-modern-cars-by-ty-thompson>
- Toyota, C. (2015). *Toyota sienna service manual: Yaw rate sensor check*. Retrieved 17<sup>th</sup> August, 2019 from: [www.tsienna.net](http://www.tsienna.net).
- Ugwu, O. O., Okafor, C. C., & Nwoji, C. U. (2018). Assessment of building maintenance in Nigerian university system: A case study of university of Nigeria, Nsukka. *Nigerian Journal of Technology*, 37(1), 44 – 52.
- Valerie, J. (2016). *How long does a traction control module last*. Retrieved 17<sup>th</sup> August, 2019 from: <https://www.yourmechanic.com/article/how-long-does-a-traction-control-module-last>.
- Wabco. (2019). *Electronic braking system (EBS)*. Retrieved 1<sup>st</sup> August, 2019 from: <https://www.wabco-auto.com/products/category-type/brake-stability-control/advanced-braking-systems/electronic-braking-system-ebs/>.
- Wong, J. Y. (2015). *Theory of ground vehicles*. New York: John Wiley and Sons, Inc.
- Yang, C., Jiao, X. & Li, L. (2015). Robust coordinated control for hybrid electric bus with single-shaft parallel hybrid powertrain. *IET Contr Theory Appl* 3(9), 270–282.