



An Ionization Based Smoke Detection and Control System

Ahmed, A.¹, Buhari, U.², Olaniyi, O. M.³, Adegboye, M. A.⁴.

Department of Computer Engineering, Federal University of Technology, Minna, Niger-state, Nigeria.

*Corresponding author: Ahmed, A, O, E-mail: aliyu.ahmed@futminna.edu.ng

Received: March 5, 2016, Accepted: April 27, 2016, Published: April 27, 2016.

ABSTRACT

The early detection of smoke particles is a cumbersome process that takes a long time in order to minimize the extent of fire outbreak. To reduce the degree of fire damage in the society and protect lives from late detection of smoke, provision of proper safety is required. This has been achieved through the installation of smoke detection and control system equipped with fast detection capability. In this paper, we present a robust ionization based smoke detection and control system with various notification mechanisms such as; buzzer, LCD, GSM and water control system. This was achieved through an automatic ionization smoke detection system designed and simulated in Proteus environment and then developed into a prototype. The results obtained shows that the system can effectively and efficiently help control possible consequences in the form of loss of lives and properties.

Keywords: Microcontroller, Ionization, Fire, Wireless Network buzzer, LCD, GSM

INTRODUCTION

Fire, man's worst enemy, man's paramount friend continues to be an essential, everyday element of people's live. People use fire to cook food, for making beacons generating heat and a lot of diverse uses. As destructive as fire can be, it still remains a very important feature to the human existence. Large industries make use of fire to render toxic wastes harmless when it burns such wastes in special incinerators. Fires also heat big boilers to generate steam, which then powers large turbine. These turbines generate electricity that provides power and heat to industries and homes. Large power plants can generate electricity using fuels such as coal, gas and even wood or garbage to make fires [1].

Fire, if not properly prevented, could result in destruction of lives and properties. Most of all destructive fires result from carelessness and late detection of smoke particles that result in such fires [2]. For example, refueling a generator set resulted to a fire burning over five houses as a result of late detection of smoke particle in Onopa, Yenagoa, Bayelsa State, Nigeria on Sunday, November 28th, 2010. Among other factors that can cause fire include carelessness in the disposal of cigarette stub at living house, car park and offices, electric sparks, electric cookers, gas cylinder [3]. Fire release poisonous gases that quickly spread from the location of fire to claim victims who are asleep and not even aware of the presence of fire. Even if the occupants are awake, the effects of exposure to the smoke can choke and render them unconscious, so, it is important to have sufficient effective and timely manner mechanism in form of warning alarm to avert such dangerous occurrences. In previous studies, it has been shown that more than half of fatal fires in home happen when people are asleep and when they are not at home [4].

Existing smoke detection systems were developed to only ring alarm. This is a local alarm system similar to warning system installed in conventional room, school to signal alerts for occupants to evacuate the premises. To expand the capability and reliability of an alarm system, a variety of features is required. It is important that smoke detection system is installed in areas where they cannot cause false alarming by steam from cooking

carbon dioxide or cooking smokes.

In order to improve the safety of occupants and properties, home security alarm system is important in the area of automated home. The necessities of the security home alarm system should have low cost, reliability, capability, easy installation, fast response and low power consumption. Several losses of lives and properties should have been prevented or minimized, if proper functioning smoke detectors with different ways of notification had been put in place. This would have given opportunities for early notification of smoke before it resulted into fire which will as a result provide time for escape, early notification of emergency fire and minimize fire damage.

In order to avoid late detection of smoke particles, there is a need for an improved smoke detection system to be developed. A smoke detector system is an electronic device that detects the present of smoke in an environment and alerts the users for emergency evacuation. In this paper, we present a robust ionization and control system with ability to detect smoke, control it, alert the users and demonstrate how the smoke sensor reacts with the change in an environment. The three different ways in which users are alerted include:

Buzzer: to beep loudly and produce electrical sound in order to notify people in the area.

Liquid crystal display (LCD): to display the information or message save on the microcontroller.

GSM: to send a short message saved on the microcontroller to the user's mobile phone.

RELATED WORK

Several works have been done in the area of smoke detection. In recent time, [5] designed a fire alarm system using radio frequency (RF) to interconnect control unit in one location to a working units that are in other locations. However, the method only covers short distance, thus, could not solve the problem of long distance messaging. Fire detection system using gas and smoke sensor developed by [6] to reduce false alarm. The drawback of this approach is the effect of false alarm in presence of water vapour methanol and dry ice.

In the approach of [7], different slave units send an RF signal to other master units in the network, to sound their alarm but the limitation is that the system only covers limited area. In [8], used video based smoke detection sensor to detect smoke particles, in their approach they provide a solution to the limitation of existing fire alarm, so that it will be able to sense smoke in the large area such as forest, and display the output with different colours but it requires the user to monitor it.

Lawrence in [9] developed fire alarm system based on image capturing, to reduce false alarm. The image captured by the system is been read in a different gray level binary number and uses histogram comparison to compare the level of gray in almost every second. This system is limited in response time and short distance.

In the approach of [10], a way of reducing false alarm by using multi-sensors is suggested, but it has limitation of short distance and failure once the battery is dead. Also author in [11], developed alarm system in video based using wavelets and supports vector machines. The output of video stream is divided into 64 blocks of 32 by 32 pixels that show the presence or absence of smoke. This system is expensive and labour intensive when it requires regular monitoring. Haven review different works on smoke detection system, we realized that smoke sensors are only interfaced to the microcontroller without the use of comparator IC which sometime leads to false alarm. The employed of comparator IC in this work eradicates this shortcoming. Also, available smoke detectors are not capable of controlling smoke, they only use audible sounds and visual light as method of alert which has little or no effect whenever occupant of such properties are not within the premises. We use DC water system to control smoke and available telecommunication network to alert remote user.

SYSTEM OVERVIEW

The overall system block diagram of the developed automatic smoke detection and control system is shown in Fig. 1. It comprises of sensor unit, power supply section, the microcontroller unit (AT89C51), water control unit, alert unit and GSM phone connected to communication network.

These units make up the system hardware while the instruction written and transfer into AT89C51 Microcontroller serve as the system software. The design considerations for each are as described as follows:

System Hardware Design and Implementation

The following subsections detailed the hardware design of the system. As it can be seen in Figure 2, the implementation comprises of all module interconnections.

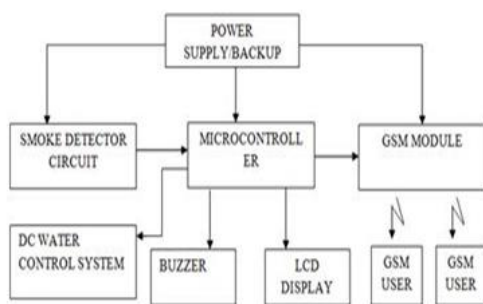

Figure 1: The system block diagram

The Input Unit: This unit also referred to as sensor unit (ionization sensor). It is made up of ionization chamber and sources of ionization radiation which comprises of two plates

separated in about a centimeter. The power (battery) source of detector applies voltage to the plate, charging one plate positive and other plate negative. When smoke enters the chamber, the smoke attaches to the ion are neutralized before getting to the plate which cause drop in current. This reduction in current between the plates indicates that the smoke has being detected. The output of the sensor based on reference voltage of comparator IC (LM358) depends on thickness of smoke particles.

The Microcontroller: Microcontroller is a functional computer system on a chip optimized to coordinate electronics device. It is designed primarily to operate on a date fed through serial or parallel ports, the data is operated under this control of a program stored in the ROM and external devices control signal fed via the input/output pin (ports). In this work, we used AT89C51 because of its easy to program, low power idle and power down modes. It sends signal (logic1) to the alert module based on input signal from sensor.

The Output Unit: The output unit helps to alert the user based on their mode of notification. In case of this work, the output devices used are buzzer, liquid crystal displays (LCD), GSM mobile and water control system. The buzzer notifies user by producing electrical sound and beeping loudly in case of if user is in the premises. LCD is used to help display message in case if the people available at the premises where alarm is ringing does know what sound is all about. GSM mobile also text alert messages to the remote user for the awareness of their house, and control system was also employ for the purpose of if the user could not be able arrive at early stage, so that it will control the smoke by spray water.

Power Unit: The power unit is the interface between main supply (AC) and system unit. The output of transformer is rectified, filtered to remove fluctuation DC and regulated by adjustable voltage (LM317) to charge battery and at the same time supply DC power to the system. The battery plan in this work serves as a backup in case of power failure. This makes it possible for the system to be operated at all time, hereby ensuring an efficient system.

Software Design Consideration

The software tools used for programming the AT89C51 are C language and IC programmer. The C language helps in development of system software, portability and provides rich set of operator. The function is to control microcontroller to initiate the output device once the input received. The circuit diagram of the system is shown in Figure 2.

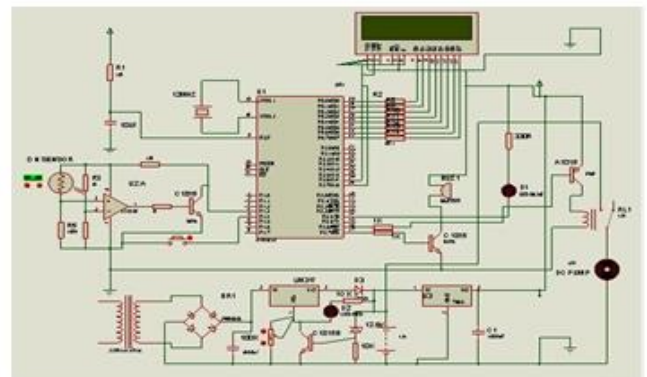

Figure 2: Detailed system design

Experimental Setup

The entire system is simulated on Proteus firstly to examine the results before implemented. Figure 3 shows the result obtains on the screen during the ready states which displays EXCUSE ME BOSS NO SMOKE DETECED.

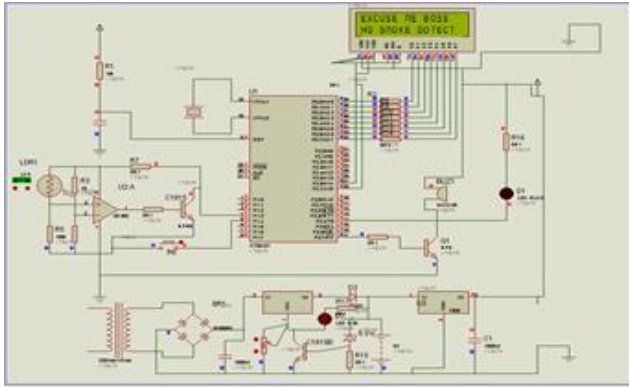

Figure 3: Simulated Circuit Ready State

After that, the switch component in Proteus is used to represent the smoke (input) in the design. Immediately this button is pressed, the system behaved as if it really detects smoke which make it to change the information on the screen to EXCUSE ME BOSS SMOKE DETECED and beep loudly. Fig. 4 shows the result of the working mode.

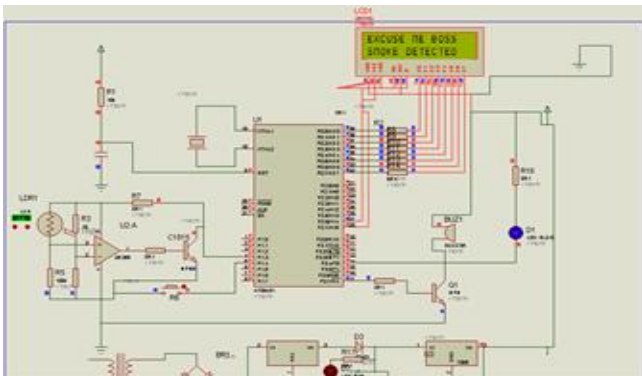

Figure 4: Simulated Circuit Working State

Working Principle of the System

The AT89C51 microcontroller was interfaced with the alarming device, DC water system, GSM mobile and liquid crystal display. Once the system switches ON (activated), the controller carries out all the necessary initialization and display “EXCUSE ME BOSS NO SMOKE DETECED”. Once smoke is detected, the comparator IC checks for the thickness of the smoke. If the present of smoke is confirmed, it then compares it with the reference value (voltage) of comparator IC to ensure that it is not a false alarm, it then send the signal to the microcontroller to trigger alarm, spray water, display message (EXCUSE ME BOSS SMOKE DETECED) on the liquid crystal display (LCD) and send message to user at their destination for proper control. If the presence of smoke persists the system will continue to ring alarm, keep the smoke detected status display on the screen, but stop to send message to the user, and eventually, activate the sprayer to spray water on the designated point of the incidence. This operation kicks in periodically until smoke is no longer detected. Figure 5 shows the flow chart of the working principle of the system.

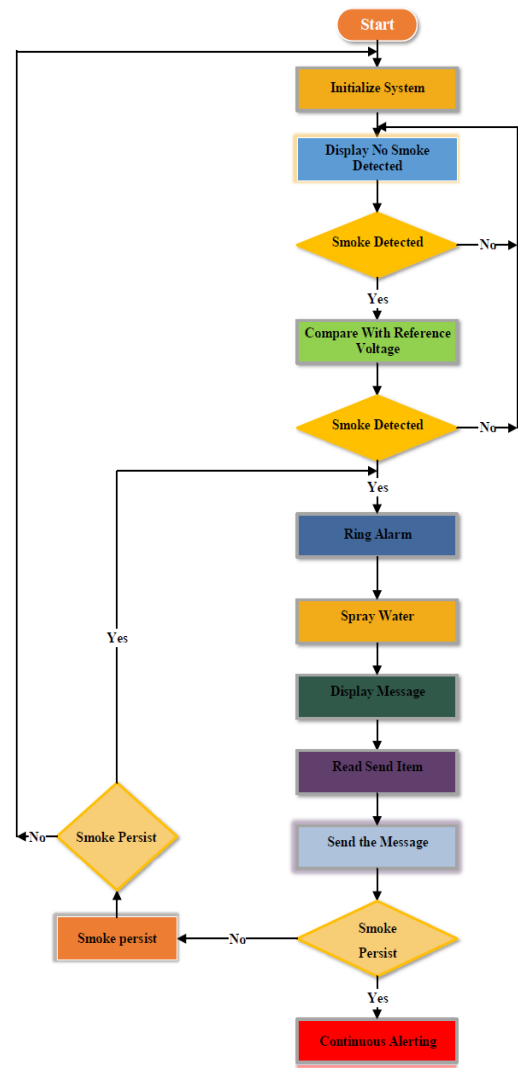

Figure 5: System operation Flowchart

Prototype Design

The implementation of smoke detection system was achieved and sub module interface to the microcontroller unit activated once the system power ON. All the components including buzzer, water control system and GSM mobile are in idle state except LCD that constantly displays ready state as show in Figure 6.

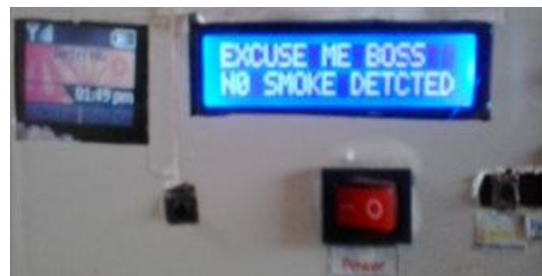

Figure 6: implemented system showing smoke not detected
The implemented system is tested in the presence of smoke with different sources of fire such as cigarette, paper foam, cotton, cloth etc. Immediately it senses the smoke it changes the message on the screen to excuse me boss smoke detected as shown in

Figure 7.



Figure 7: implemented system showing smoke detected

System Evaluation

The implemented system is tested in the presence of smoke particle from different materials such as paper burning, cloth, foam cigarette, cable as shown in the Table I. The sensor is positioned in the direction opposite to the smoke particle at 8ft interval to the device. After some second Short Message Service was received on the phone no in which message send to. The time difference in which system response to smoke generated from these materials are presented in the Table 1.

Table 1: Result Obtain From the System

Material (Smoke Sources)	Response Time (mins.)
Cigarette	0.00
Paper	0.45
Cloth	1.25
Flexible Foam	5.35
PVC Wire	7.38
Cotton	1.08
Printed Circuit	2.50
Cooking Smoke	0.52

The Response Time of an existing System tested under similar materials is shown in Table 2.

Table 1: Result Obtain From the System

Material (Smoke Sources)	Response Time (mins.)
Wood Crib	13.09
Cloth Fabric	1.07
Polyurethane Foam	7.20
PVC	7.20

Figure 8 shows the comparative plot of response times with respect to material of our system against the existing system.

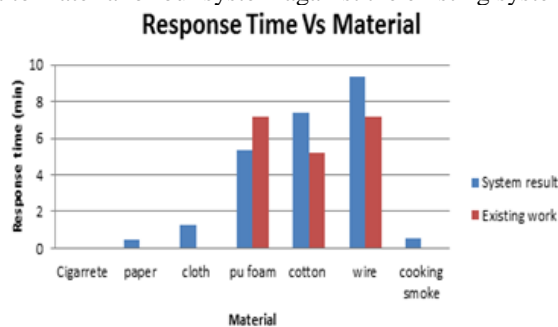

Figure 8: Response Time vs Materials

From Figure 8, it can be seen that the system developed has a

superior response time as compared to the state of the art with the exception of Polyurethane foam material.

CONCLUSION

In this work, a smoke detection and control system proven to be effective and efficient in the detection of smoke particles at early stage in a test zone has been developed. This system can display text, ring alarm, send SMS alert to specified users and spray water, thereby reducing the extent of fire damage.

As a result, the system responds at a faster rate and is capable of preventing fire outbreak at early stage under favorable condition compared to the existing systems. To improve the overall performance of this system, it is recommended that the system be designed such that it can receive SMS response from remote users to determine which action to be taken. Furthermore, the system should use more than one GSM with different network providers in case of network failure. Lastly, fire extinguisher can also be used in the design if there is no water in the reservoir.

REFERENCES

1. T. Muhammad and M. Khalid, "Sugas industry: A cheap and easy source of electricity. (a case study of district mand: Bahauddin)," *Universal Journal of Management and Social Science*, vol. 2, pp. 97–103, 2012.
2. Editorial. (2012, December) preventing incessant fire outbreaks. [Online]. Available: <http://www.punchng.com>
3. Admin. (2010, Dec.) Fire outbreak in Nigeria. [Online]. Available: <http://www.thetidenewonline.com>
4. S. Ananthram, Z. Qing, and H. Yaowin, *Wireless Sensors Networks, Signal Processing and Communication Perspectives*. Chichester: John Wiley & Sons Ltd, 2007.
5. E. Hussan, "Intelligent fire alarm system," *Journal of American Science*, pp. 1016–1024, 2012.
6. J. Shin, H. Chrish, and A. P. Kristen, "Fire detection using smoke and gas sensor," *Fire Safety Journal*, pp. 1–32, 2007.
7. Q. Rashedul, A. S. Ehsanul, and H. M. Kamrul, "Enhanced wireless control system for smoke and fire detection," *International Journal of Science and Engineering Research*, vol. 3, pp. 1–5, 2012.
8. S. A. Yulianto, R. W. Muhammed, and K. Gandjork, "A means of obtaining criteria for the activation of video-based smoke detection," *International Journal of Video and Image Processing and Network Security*, vol. 11, pp. 18–26, 2011.
9. S. Lawrence, "Study on the video smoke detection system," *International Journal on Engineering Performance-Based Fire Code*, vol. 6, pp. 258–263, 2004.
10. K. Fong, "Review of fire detection problem," *International Journal of Engineering Performance-Based Fire Code*, vol. 1, pp. 21–23, 2010.
11. G. Jayavardhara, M. Slaven, and P. Marimuthu, "Smoke detection in video using wavelets and support vectors machines," *Fire Safety Journal*, pp. 1–6, 2009.

Citation: Ahmed, A *et al.* (2016). T An Ionization Based Smoke Detection and Control System. J. of Advancement in Engineering and Technology, V4I2. DOI: 10.15297/JAET.V4I2.03.

Copyright: © 2016 Md. Ahmed, A. This is an open-access article distributed under the terms of the Creative Commons Attribution License, which permits unrestricted use, distribution, and reproduction in any medium, provided the original author and source are credited